

Toothed belt axis unit ELGE-TB

FESTO

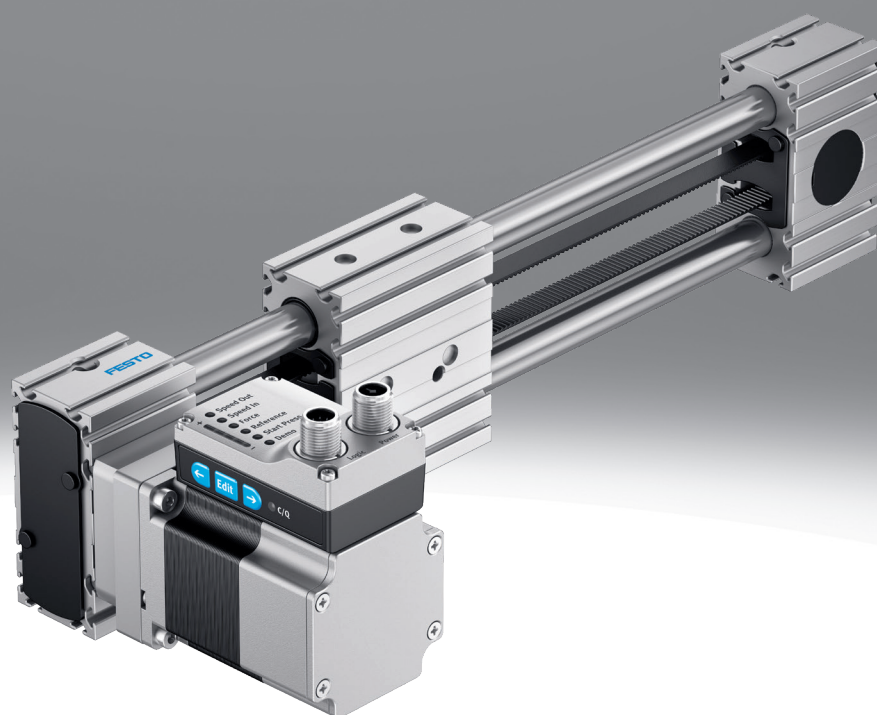

Characteristics

At a glance

Further information → [elge-tb](#)

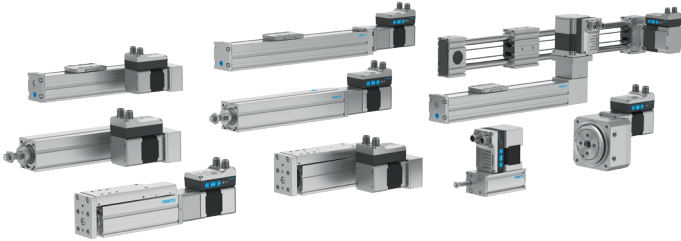

The simplicity of pneumatics is now combined for the first time with the advantages of electric automation thanks to the Simplified Motion Series. These integrated drives are the perfect solution for users who are looking for an electric alternative for very simple motion and positioning tasks between two mechanical end positions, but don't want the commissioning process for traditional electric drive systems that can often be quite complex.

- No external servo drive: all necessary electronic components combined in the integrated drive
- Two control options integrated as standard: digital I/O and IO-Link®
- Complete solution for simple movements between mechanical end positions
- Simplified commissioning: all parameters can be manually set directly on the drive
- No special knowledge required for commissioning
- Free choice of flexible motor mounting on four sides
- Cost-optimised design for simpler and very economical tasks with a service life of 5000 km

Ordering data - modular system

Further information → [elge-tb](#)

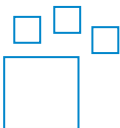

Configurable product

This product and all its product options can be ordered online via the configurator.

Engineering tools

Further information → [engineering tools](#)



Save time with engineering tools Smart Engineering for the optimal solution. Our goal is to increase your productivity. Our engineering tools play an integral part in this. They help you size your system correctly, tap into unimagined productivity reserves and generate additional productivity along the entire value chain. In every phase of your project, from the initial contact to the modernisation of your machine, you will come across a number of different tools which will be of use to you.

Simplified Motion Series - Solution Finder

- Selection tool for simple electric drive solutions from the Simplified Motion Series: This Solution Finder makes finding solutions for electric motion tasks child's play. All you have to do is enter the main application parameters like stroke, payload and motion type, and the system suggests the best solution for your simple motion task in seconds. Then you can simply add it to your shopping basket with just one click and order it online.

Diagrams

Further information → [elge-tb](#)



The diagrams shown in this document are also available online. These can be used to display precise values.

Drive system

[TB] Toothed belt

- For applications where a high dynamic response and short positioning times are required
- For long strokes
- For lower loads
- Low noise

Characteristics

Motor type

IO-Link

- The motor is integrated into the drive and can be easily commissioned according to the “plug and work” principle. The relevant parameters can be set directly on the drive. Control is via digital I/O or IO-Link.
- The service life of the motor at nominal power is 20000 h.

Control panel

When aligning the motor, make sure that the buttons (for parameterisation and control) can be used.

[H1] Integrated

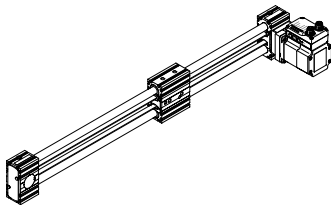

Bus protocol/activation

PNP or NPN switching outputs can be selected for actuation.

End-position sensing

End position feedback similar to a conventional proximity switch, integrated as standard

Cable outlet direction

Describes the alignment of the motor on the drive. Depending on the alignment, the connecting cables can be routed according to the customer's specifications. The cables are positioned at a 45° angle to the axis.

[AT] Top

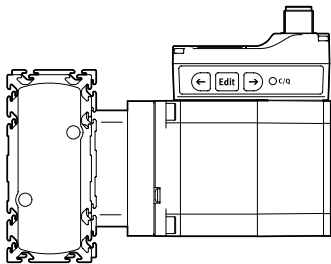

[AD] Underneath

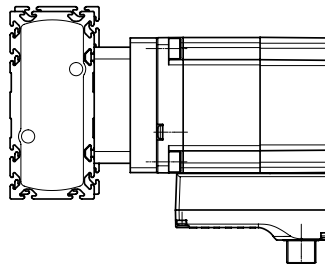

[AL] Left

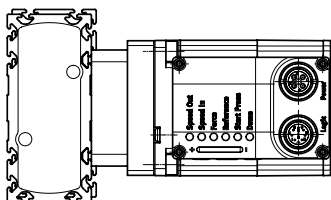

[AR] Right

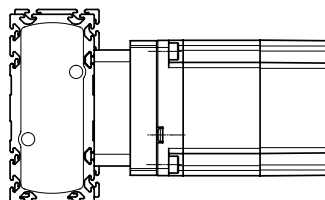

Characteristics

Motor position

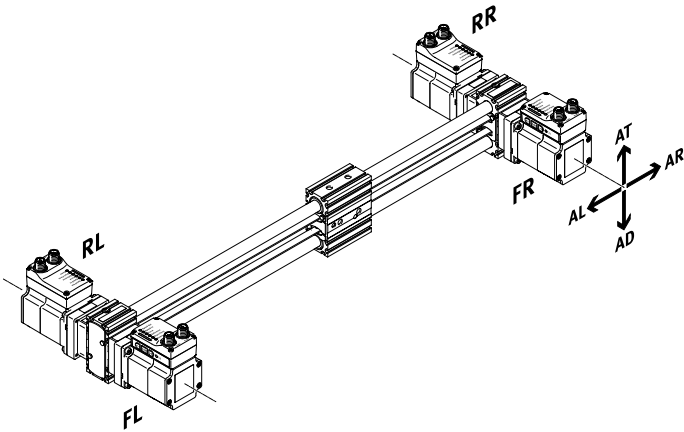

Electrical accessories

Connecting cable between the motor and IO-Link master

Type code

001	Series	
ELGE	Gantry axis	
002	Drive system	
TB	Toothed belt	
003	Guide	
	Recirculating ball bearing guide	
004	Size	
35	35	
005	Stroke [mm]	
50	50	
100	100	
150	150	
200	200	
250	250	
300	300	
350	350	
400	400	
450	450	
500	500	
550	550	
600	600	
650	650	
700	700	
750	750	
800	800	
006	Stroke reserve	
OH	None	
007	Motor type	
ST	Stepper motor ST	
008	Controller	
M	Integrated	

009	Control panel	
H1	Integrated	
010	Bus protocol/activation	
PLK	PNP and IO-Link®	
NLK	NPN and IO-Link®	
011	End-position sensing	
AA	With integrated end-position sensing	
012	Cable outlet direction	
AT	Top	
AD	Underneath	
AL	Left	
AR	Right	
013	Motor position	
FR	Front right	
FL	Front left	
RR	Rear right	
RL	Rear left	
014	Profile mounting	
...	1 ... 2	
015	Proximity sensor, inductive, slot 8, N/O contact, cable 7.5 m	
...	0 ... 99	
016	Proximity sensor, inductive, slot 8, N/C contact, cable 7.5 m	
...	1 ... 6	
017	Slot nut for mounting slot	
...	1 ... 99	
018	Electrical accessories	
	None	
L1	Adapter for operation as IO-Link® device	

Datasheet

General technical data

Size	35
Design	Electromechanical linear axis, With toothed belt, With integrated drive
Type of motor	Stepper motor
Guide	Recirculating ball bearing guide
Mounting position	Horizontal
Working stroke	50 ... 800 mm
Additional functions	User interface Built-in end-position sensing Integrated end-position sensing
Display	LED
Referencing	Positive fixed stop block Negative fixed stop block
Max. cable length	15 m outputs 15 m inputs 20 m with IO-Link® operation

Mechanical data

Size	35
Reference value effective load, horizontal	2.8 kg
Max. feed force F _x	50 N
Max. speed ¹⁾	0.48 ... 1.2 m/s
Speed "Speed press"	0.024 m/s
Max. acceleration ²⁾	8.5 m/s ²
Repetition accuracy	±0.1 mm
Position detection	Motor encoder Via proximity switch

1) It is not possible to reach the maximum speed of 1.2 m/s with strokes < 250 mm.

Adjustable in increments of 10%

2) Parameter cannot be changed

Toothed belt

Size	35
Toothed-belt pitch	2 mm
Effective diameter of drive pinion	18.46 mm
Feed constant	58 mm/U

Electrical data

Size	35
Nominal voltage DC	24 V
Permissible voltage fluctuations	+/- 15%
Nominal current	5.3 A
Max. current consumption	5.3 A
Max. current consumption, logic	0.3 A
Rotor position sensor	Absolute single-turn encoder
Rotor position sensor, encoder measuring principle	Magnetic
Rotor position transducer resolution	16 bit

Datasheet

Interfaces	
Size	35
Parameterisation interface	IO-Link, User interface
Working range of logic input	24 V
Number of digital logic inputs	2
Features of logic input	Configurable Not galvanically isolated
Switching logic for inputs	NPN (negative switching) PNP (positive switching)
Specification logic input	Based on IEC 61131-2, type 1
Max. current digital logic outputs	100 mA
Number of digital logic outputs 24 V DC	2
Features of digital logic outputs	Configurable Not galvanically isolated
Switching logic for outputs	NPN (negative switching) PNP (positive switching)

Technical data IO-Link®	
Size	35
IO-Link, SIO-Mode support	Yes
IO-Link, communication mode	COM3 (230.4 kBaud)
IO-Link, Port class	A
IO-Link, Number of ports	Device 1
IO-Link, Process data length OUT	2 bytes
IO-Link, Process data content OUT	Move in 1 bit Move out 1 bit Quit Error 1 bit Move intermediate 1 bit
IO-Link, Process data length IN	2 bytes
IO-Link, Process data content IN	State In 1 bit State Out 1 bit State Move 1 bit State Device 1 bit State Intermediate 1 bit
IO-Link, Service data IN	32-bit force 32-bit position 32-bit speed
IO-Link, Min. cycle time	1 ms
IO-Link, Data storage required	0.5 KB
IO-Link, Protocol version	Device V 1.1

Datasheet

Operating and environmental conditions

Size	35
Ambient temperature	0 ... 50°C
Storage temperature	-20 ... 60°C
Note on ambient temperature	Power must be reduced by 2% per K at ambient temperatures above 30°C.
Temperature monitoring	Switch-off for excessive temperature Integrated precise CMOS temperature sensor with analogue output
Relative air humidity	0 - 90%
Insulation protection class	B
Protection class	III
Degree of protection	IP20
Duty cycle	100%
CE mark (see declaration of conformity)	To EU EMC Directive In accordance with EU RoHS Directive
CE marking (see declaration of conformity)	To UK instructions for EMC To UK RoHS instructions
KC mark	KC-EMV
Approval	RCM trademark
Vibration resistance	Transport application test with severity level 2 to FN 942017-4 and EN 60068-2-6
Shock resistance	Shock test with severity level 2 to FN 942017-5 and EN 60068-2-27
Maintenance interval	Life-time lubrication

Weight

Size	35
Basic weight for 0 mm stroke	2,490 g
Additional weight per 10 mm stroke	25 g

Materials

Material profile	Anodised wrought aluminium alloy
Material slide	Anodised wrought aluminium alloy
Material toothed belt	Polychloroprene with glass filament and nylon coating
Material pulleys	High-alloy stainless steel
LABS (PWIS) conformity	VDMA24364 zone III
Note on materials	RoHS-compliant

Load values

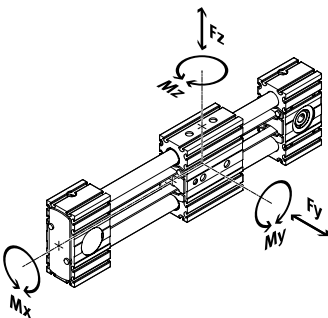

The indicated forces and torques refer to the centre of the guide. The point of application is the intersection of the centre of the guide and the centre of the length of the slide. They must not be exceeded in dynamic operation. Special attention must be paid to the deceleration process.

Permissible forces and torques for the guide calculation with reference service life

Size	35
Reference service life	5,000 km
Max. force F_y	50 N
Max. force F_z	50 N
Max. moment M_x	2.5 Nm
Max. moment M_y	8 Nm
Max. moment M_z	8 Nm

Datasheet

Calculating the load comparison factor

$$f_v = \frac{|F_{y1}|}{F_{y2}} + \frac{|F_{z1}|}{F_{z2}} + \frac{|M_{x1}|}{M_{x2}} + \frac{|M_{y1}|}{M_{y2}} + \frac{|M_{z1}|}{M_{z2}} \leq 1$$

If the axis is subjected to several of the indicated forces and torques at the same time, the following equation must be satisfied in addition to the indicated maximum loads.

For a guide system to have a service life of 5000 km, the load comparison factor must have a value of $f_v < 1$, based on the maximum permissible forces and torques for a service life of 5000 km. This formula can be used to calculate a guide value. The engineering software "Electric Motion Sizing" is available for more precise calculations.

F1 / M1 = dynamic value

F2 / M2 = maximum value

Calculating the service life of the guide

The service life of the guide depends on the load. To provide a rough indication of the service life of the guide, the graph below plots the load comparison factor f_v against the service life.

These values are only theoretical. You must consult your local Festo contact for a load comparison factor f_v greater than 1.

Load comparison factor f_v as a function of service life l

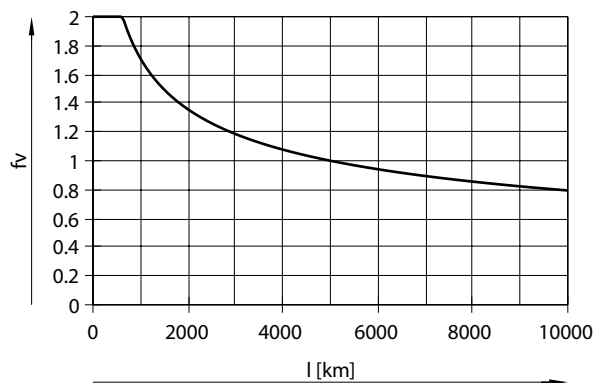

Example:

A user wants to move a X kg load. The calculation gives a value of 1.5 for the load comparison factor f_v . According to the graph, the guide would have a service life of approx. 1500 km. Reducing the acceleration reduces the M_y and M_z values. A load comparison factor f_v of 1 now results in a service life of 5000 km.

2nd moment of area

Size	35
2nd moment of area I_y	3,770 mm ⁴
2nd moment of area I_z	4,190 mm ⁴

Recommended deflection limits

Adherence to the maximum deflection of 0.5 mm is recommended so as not to impair the functionality of the axes. Greater deformations can result in increased friction, increased wear and reduced service life.

Datasheet

Sizing example

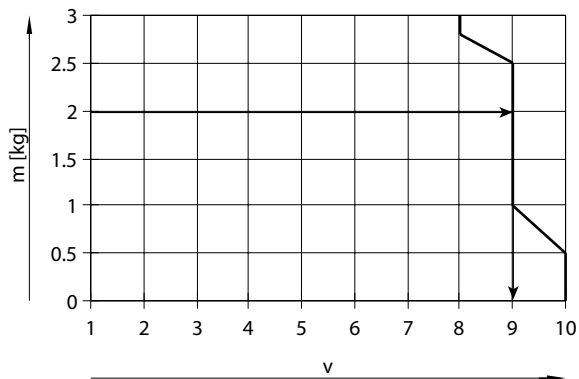

ELGE-TB-35

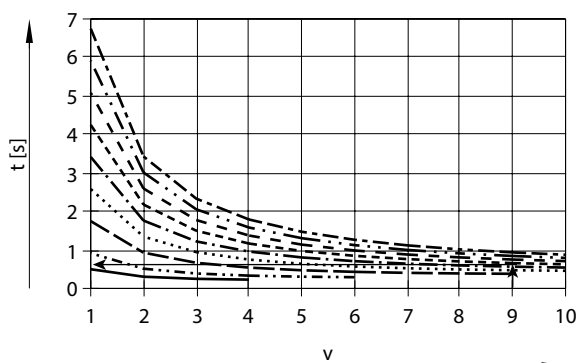

l = 50 mm
 l = 100 mm
 l = 200 mm
 l = 300 mm
 l = 400 mm
 l = 500 mm
 l = 600 mm
 l = 700 mm
 l = 800 mm

Application data:

- Payload: 2 kg
- Mounting position: horizontal
- Motor attachment position: axial
- Stroke: 600 mm
- Max. permissible positioning time: 1 s (one direction)

Step 1:

Max. payload = 2.8 kg; ELGE-TB-35-600

Step 2:

Selecting the max. speed level v for payload m (see diagram on the left)

Step 3:

Reading off the min. positioning time t for stroke l (see diagram on the left)

Result: the application can be realised with ELGE-TB-35-600. A minimum positioning time (one direction) of 0.75 s is achieved.

Longer positioning times can be selected at any time by using a lower speed setting.

Mass m as a function of speed level v

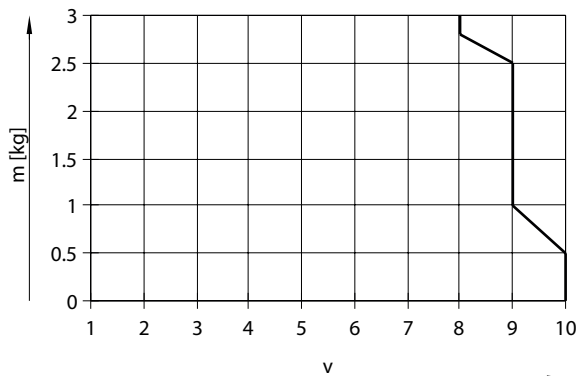

ELGE-TB-35

Note:

The lines represent the maximum values. The lower speed settings can be set at any time.

Datasheet

Positioning time t as a function of speed level v and stroke l

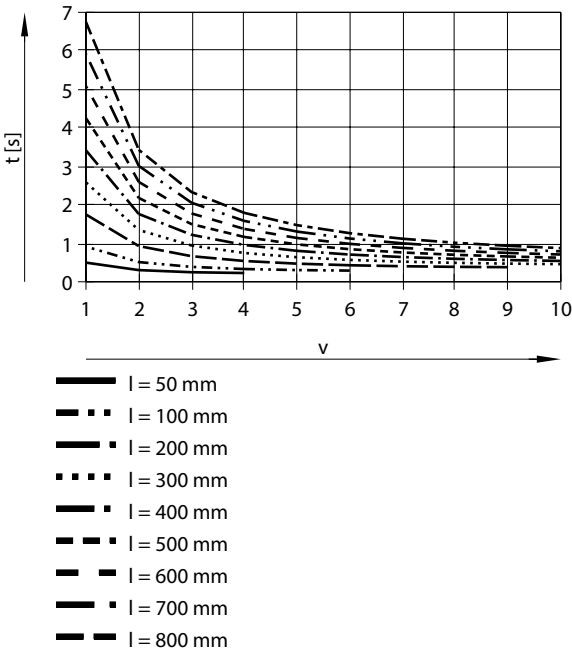

Feed force F as a function of force level $F1$

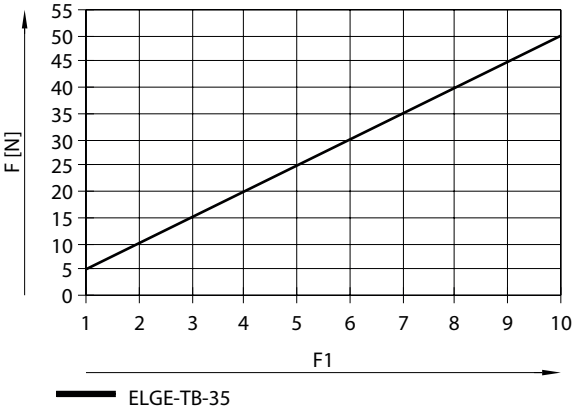

Dimensions

Download CAD data → www.festo.com

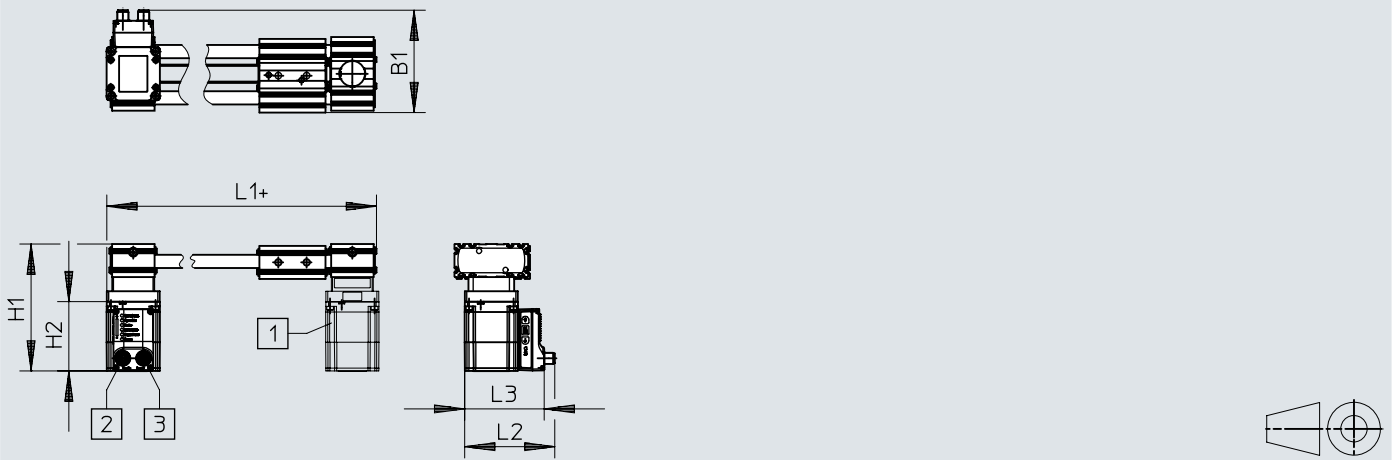

- [1] Motor
- [2] Connection to logic interface
- [3] Connection to power supply
- [4] + = plus stroke length

	B1	H1	H2	L1	L2	L3
ELGE...-AT-FL	108,3	134,5	73,5	180,7	95,6	84,3
ELGE...-AD-FR	108,3	134,5	73,5	180,7	95,6	84,3

Dimensions

Dimensions – ELGE-...-AR/AL

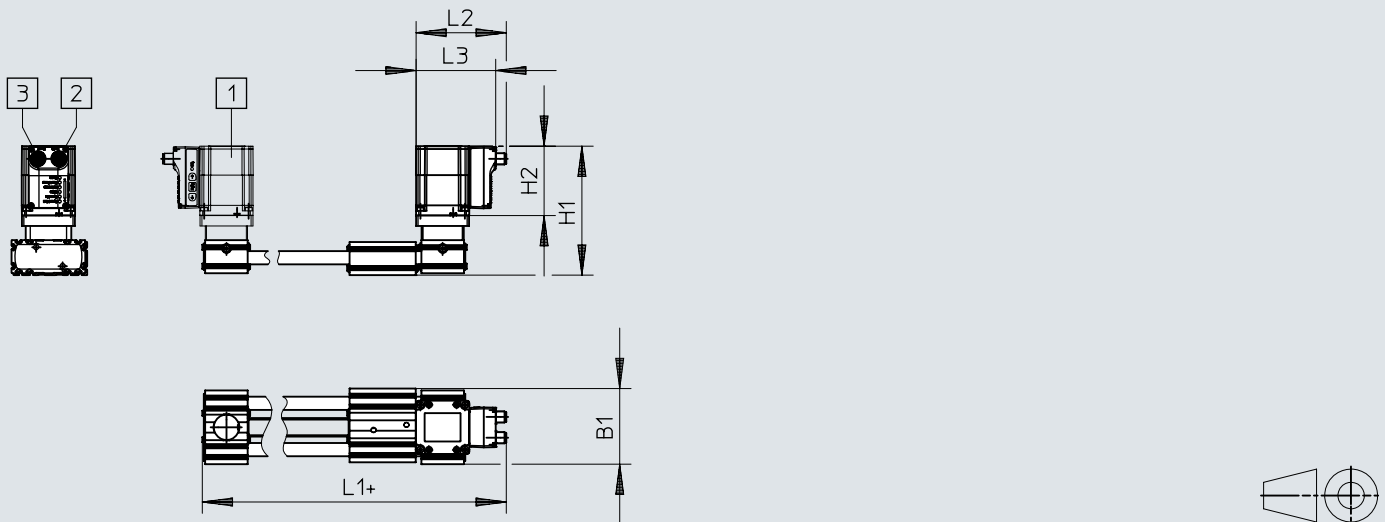
Download CAD data → www.festo.com

- [1] Motor
- [2] Connection to logic interface
- [3] Connection to power supply
- [4] + = plus stroke length

	B1	H1	H2	L1	L2	L3
ELGE-...-AR-RR	80	136,5	73,5	219,8	95,6	84,3
ELGE-...-AL-RL	80	136,5	73,5	219,8	95,6	84,3

Dimensions

Dimensions – ELGR-35

Download CAD data → www.festo.com

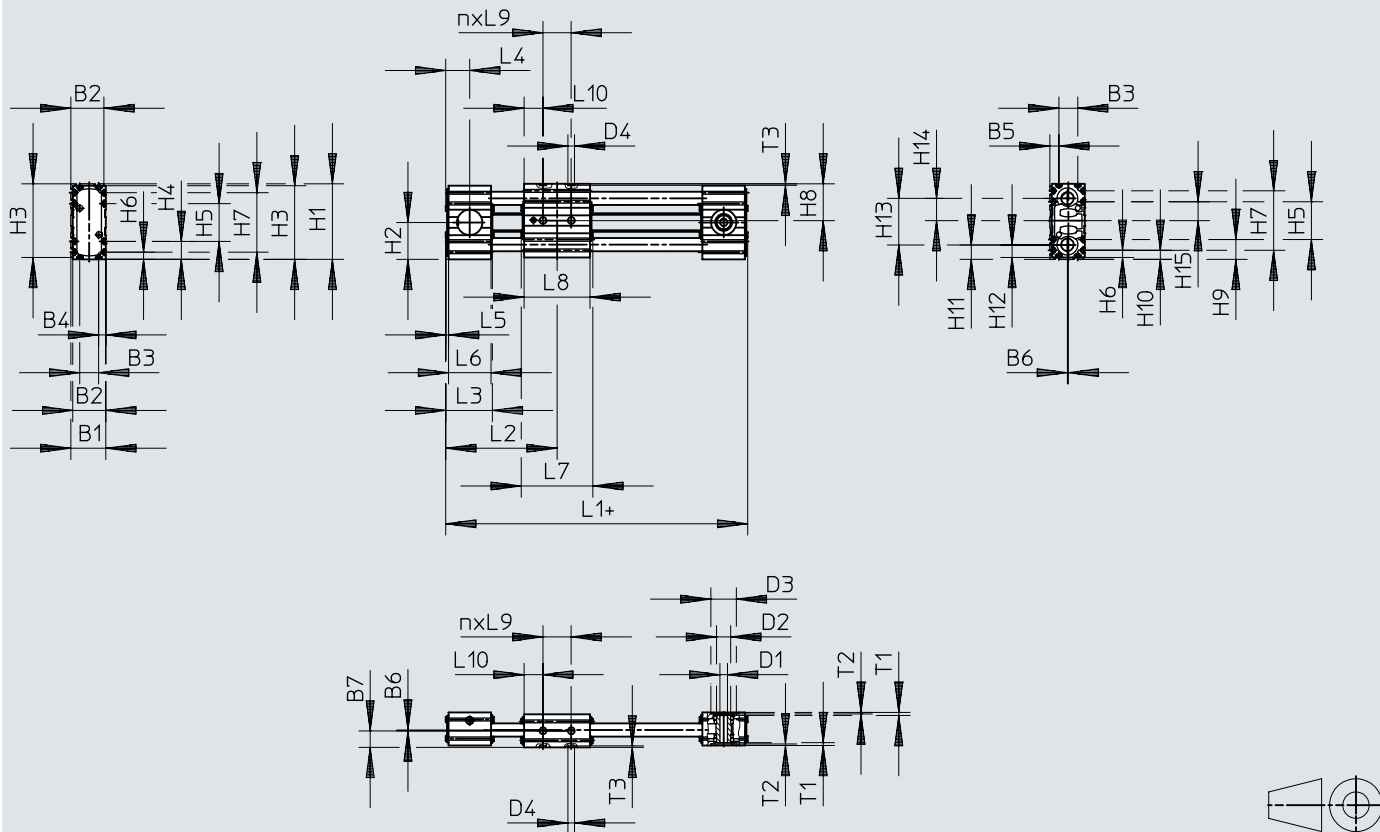

[1] + = plus stroke length

	B1	B2	B3	B4	B5	B6	B7	D1 ∅ H7	D2 ∅	D3 ∅ H7	D4 ∅ H7	H1	H2	H3	H4	H5	H6
ELGE-35	37	35	20	7,5	9,5	1	17,5	8	15	27	7	80	39	78	19	40	7,5
	H7	H8	H9	H10	H11	H12	H13	H14	H15	L3	L4	L5	L6	L9	T1	T2	T3 +0,1
ELGE-35	63	39	21	9,5	15,5	13,5	49	23,5	20	51	25,5	3	45	30	3,1	1,6	1,6
	L1		L2		L7		L8		L10		n						
ELGE-35	178		89		76		70		20		1						

Dimensions

Dimensions – Profile ELGR-35

Download CAD data → www.festo.com

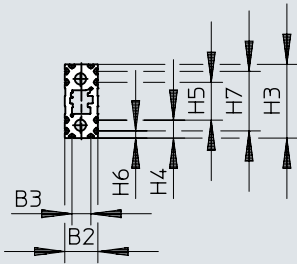

	B2	B3	H3	H4	H5	H6	H7
ELGE-35	35	20	78	19	40	7,5	63

Dimensions

Dimensions – Profile mounting MUE

Download CAD data → www.festo.com

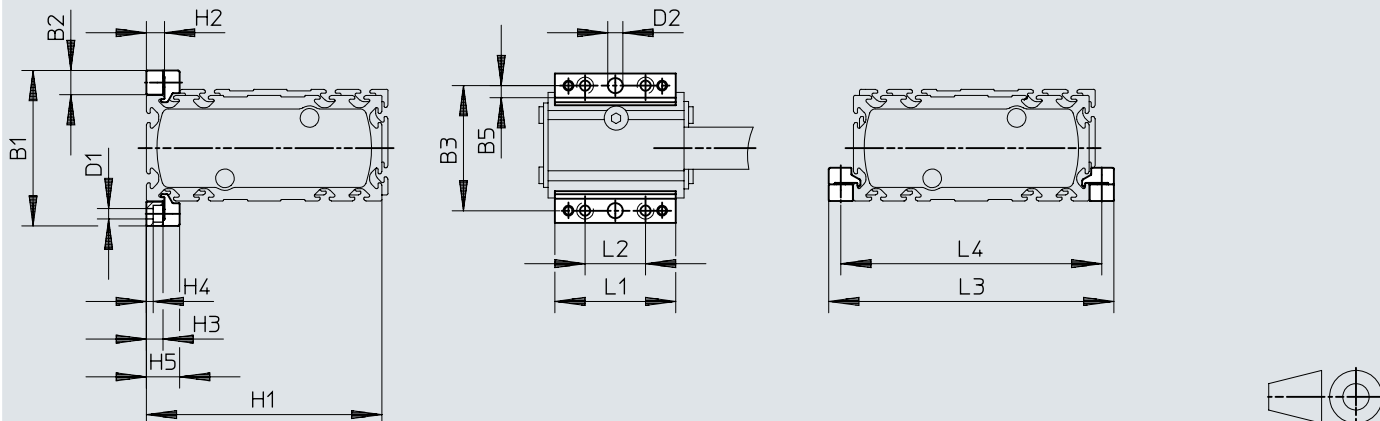

		B1	B2	B3	B5	D1 ∅	D2 ∅ H7	H1	H2
MUE-50	ELGE-35	51	8	43	4	3,4	5	78	6

		H3	H4	H5	L1	L2	L3	L4
MUE-50	ELGE-35	5,5	2,3	11	40	20	94	86

Dimensions

Dimensions – Sensor bracket EAPM-...-SHS, switch lug EAPM-...-SLS

Download CAD data → www.festo.com

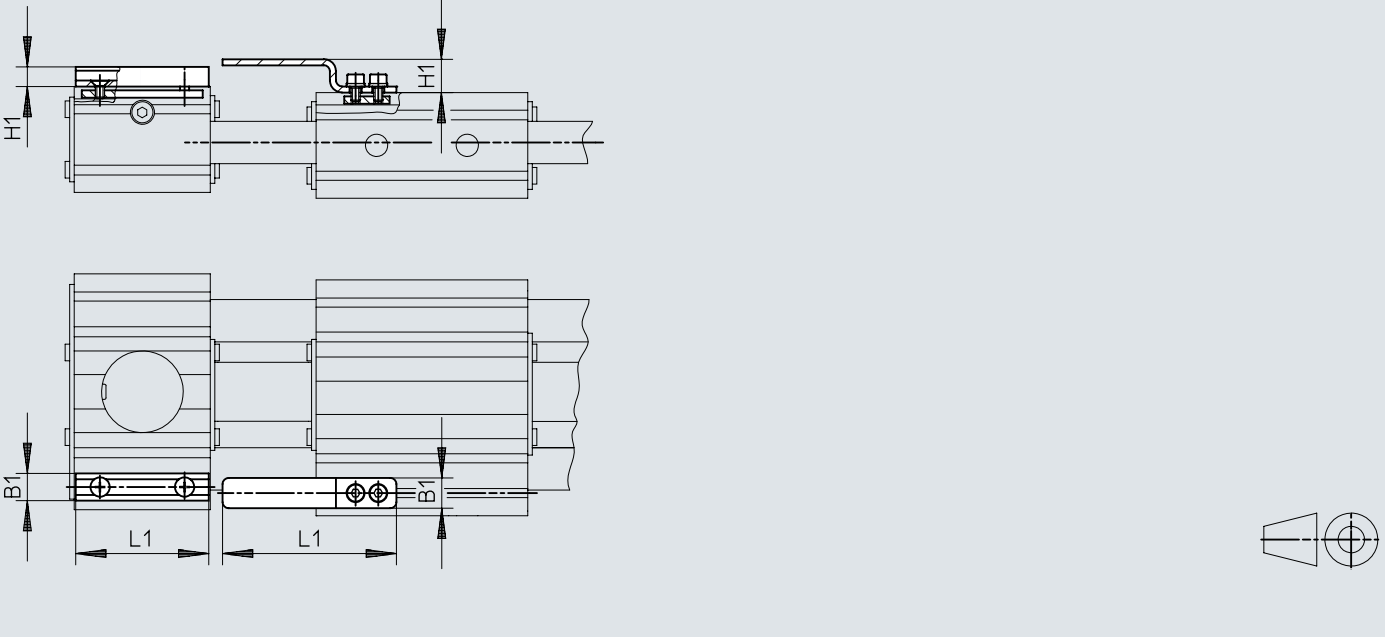

		B1	H1	L1
EAPM-L4-SHS	ELGE-35	9	6,5	44
EAPM-L4-SLS	ELGE-35	10	11	57,5

Ordering data

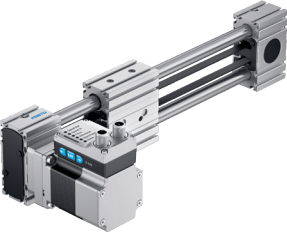
Ordering data				
	Size	Stroke [mm]	Part no.	Type
	35	100 mm	8083931	ELGE-TB-35-100-0H-ST-M-H1-PLK-AA-AT-FR
		200 mm	8083932	ELGE-TB-35-200-0H-ST-M-H1-PLK-AA-AT-FR
		300 mm	8083933	ELGE-TB-35-300-0H-ST-M-H1-PLK-AA-AT-FR
		400 mm	8083934	ELGE-TB-35-400-0H-ST-M-H1-PLK-AA-AT-FR
		500 mm	8083935	ELGE-TB-35-500-0H-ST-M-H1-PLK-AA-AT-FR
		600 mm	8083936	ELGE-TB-35-600-0H-ST-M-H1-PLK-AA-AT-FR

Ordering table			
	Size	Part no.	Type
	35	8083929	ELGE-TB-35-

Peripherals

Peripherals overview

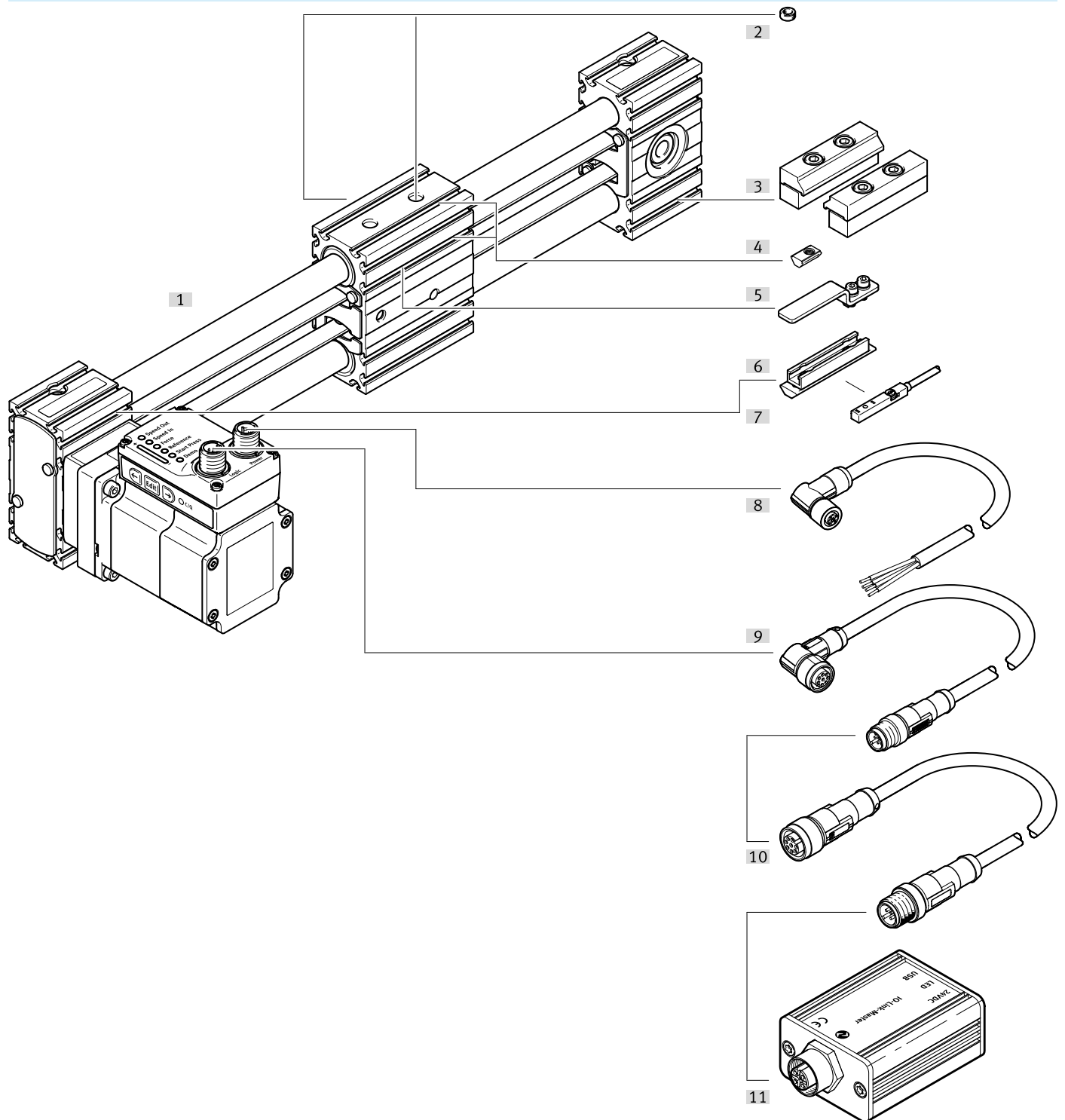



Accessories

Type/order code	Description	→ Link
[1] Toothed belt axis unit ELGE-TB	Electric drive	elge-tb
[2] Centring sleeve ZBH	<ul style="list-style-type: none"> • For centring loads and attachments on the slide • 2 centring sleeves included in the scope of delivery for the axis 	
[3] Profile mounting MUE	For mounting the axis on the bearing cap	21
[4] Slot nut NST	For mounting attachments	21
[5] Switch lug EAPM-L4-SLS	For sensing the slide position	21
[6] Sensor bracket EAPM-L4-SHS	Adapter for mounting the inductive proximity sensors on the axis	21

Peripherals

Accessories		→ Link
Type/order code	Description	
[7] Proximity switch, T-slot SIES-8M	<ul style="list-style-type: none"> • Inductive proximity sensor, for T-slot • The order code SA, SB includes 1 switch lug and 1 sensor bracket in the scope of delivery • Proximity switches are optional and only required in order to sense any intermediate positions 	21
[8] Supply cable NEBL-T12	For connecting the load and logic supply	22
[9] Connecting cable NEBC-M12	For connection to a controller	23
[10] Adapter NEFC-M12G8	Connection between the motor and the IO-Link® master	22
[11] IO-Link® master USB CDSU-1	For straightforward use of the mini slide unit with IO-Link	22

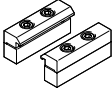
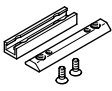
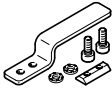
Accessories

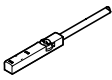
Profile mounting MUE						
	Note on materials	Product weight	Part no.	Type		
	RoHS-compliant	20 g	★ 558042	MUE-50		
Sensor bracket EAPM-...-SHS						
	Material sensor bracket	Note on materials	Product weight	Part no.	Type	
	Wrought aluminium alloy, Anodised	RoHS-compliant	20 g	567537	EAPM-L4-SHS	
Switch lug EAPM-...-SLS						
	Material switch lug	Note on materials	Product weight	Part no.	Type	
	Steel, Galvanised	RoHS-compliant	15 g	567538	EAPM-L4-SLS	
Slot nut NST						
	Note on materials	Product weight	Part no.	Type		
	RoHS-compliant	0.3 g	558045	ABAN-3-1 M3-4-M-P1		
Centring pin ZBS/centring sleeve ZBH						
	Material sleeve	Size of pack	Product weight	Part no.	Type	
	Steel	10	1 g	8146544	ZBH-7-B	
Proximity switch SIES for T-slot, inductive						
	Switching output	Switching element function	Electrical connection 1, connector system	Cable length ¹⁾	Part no.	Type
	NPN	N/C contact	M8x1, A-coded, to EN 61076-2-104	0.3 m	★ 551402	SIES-8M-NO-24V-K-0,3-M8D
			Open end	7.5 m	★ 551401	SIES-8M-NO-24V-K-7,5-OE
		N/O contact	M8x1, A-coded, to EN 61076-2-104	0.3 m	551397	SIES-8M-NS-24V-K-0,3-M8D
			Open end	7.5 m	551396	SIES-8M-NS-24V-K-7,5-OE
	PNP	N/C contact	M8x1, A-coded, to EN 61076-2-104	0.3 m	★ 551392	SIES-8M-PO-24V-K-0,3-M8D
			Open end	7.5 m	★ 551391	SIES-8M-PO-24V-K-7,5-OE
		N/O contact	M8x1, A-coded, to EN 61076-2-104	0.3 m	551387	SIES-8M-PS-24V-K-0,3-M8D
			Open end	7.5 m	551386	SIES-8M-PS-24V-K-7,5-OE

1) Proximity switches are optional and are only required for sensing any intermediate positions.

Accessories

IO-Link® master USB		Part no.	Type
Description			
	For using the unit with IO-Link®, an external power supply plug is also required (not included in the scope of delivery)	8091509	CDSU-1

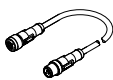
Adapter NEFC						
	Electrical connection 1, connector system	Electrical connection 2, connector system	Electrical connection 2, number of connections/cores	Cable length ¹⁾	Part no.	Type
	M12x1, A-coded to EN 61076-2-101	M12x1, A-coded to EN 61076-2-101	5	0.3 m	8080777	NEFC-M12G8-0.3-M12G5-LK

1) Connection between the motor and the IO-Link® master

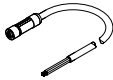
Supply cables NEBL, straight						
	Electrical connection 1, connector system	Electrical connection 2, connector system	Electrical connection 2, number of connections/cores	Cable length	Part no.	Type
	M12x1, T-coded according to EN 61076-2-111	Open end	4	2 m	8080790	NEBL-T12G4-E-2-N-LE4
				5 m	8080791	NEBL-T12G4-E-5-N-LE4
				10 m	8080792	NEBL-T12G4-E-10-N-LE4
				15 m	8080793	NEBL-T12G4-E-15-N-LE4

Supply cables NEBL, angled						
	Electrical connection 1, connector system	Electrical connection 2, connector system	Electrical connection 2, number of connections/cores	Cable length	Part no.	Type
	M12x1, T-coded according to EN 61076-2-111	Open end	4	2 m	8080778	NEBL-T12W4-E-2-N-LE4
				5 m	8080779	NEBL-T12W4-E-5-N-LE4
				10 m	8080780	NEBL-T12W4-E-10-N-LE4
				15 m	8080781	NEBL-T12W4-E-15-N-LE4

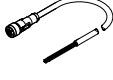
Connecting cables NEBC, straight						
	Electrical connection 1, connector system	Electrical connection 2, connector system	Electrical connection 2, number of connections/cores	Cable length	Part no.	Type
	M12x1, A-coded to EN 61076-2-101	M12x1, A-coded to EN 61076-2-101	8	2 m	8080782	NEBC-M12G8-E-2-N-M12G8
				5 m	8080783	NEBC-M12G8-E-5-N-M12G8
				10 m	8080784	NEBC-M12G8-E-10-N-M12G8
				15 m	8080785	NEBC-M12G8-E-15-N-M12G8
		Open end	2 m	8094480	NEBC-M12G8-E-2-N-B-LE8	
			5 m	8094477	NEBC-M12G8-E-5-N-B-LE8	
			10 m	8094482	NEBC-M12G8-E-10-N-B-LE8	
			15 m	8094475	NEBC-M12G8-E-15-N-B-LE8	

Accessories

Connecting cables NEBC, angled							
	Electrical connection 1, connector system	Electrical connection 2, connector system	Electrical connection 2, number of connections/ cores	Cable length	Part no.	Type	
	M12x1, A-coded to EN 61076-2-101	M12x1, A-coded to EN 61076-2-101	8	2 m	8080786	NEBC-M12W8-E-2-N-M12G8	
				5 m	8080787	NEBC-M12W8-E-5-N-M12G8	
				10 m	8080788	NEBC-M12W8-E-10-N-M12G8	
				15 m	8080789	NEBC-M12W8-E-15-N-M12G8	
		Open end			2 m	8094476	NEBC-M12W8-E-2-N-B-LE8
	5 m				8094478	NEBC-M12W8-E-5-N-B-LE8	
	10 m				8094481	NEBC-M12W8-E-10-N-B-LE8	
	15 m				8094479	NEBC-M12W8-E-15-N-B-LE8	