

Balancer kits YHBP

FESTO

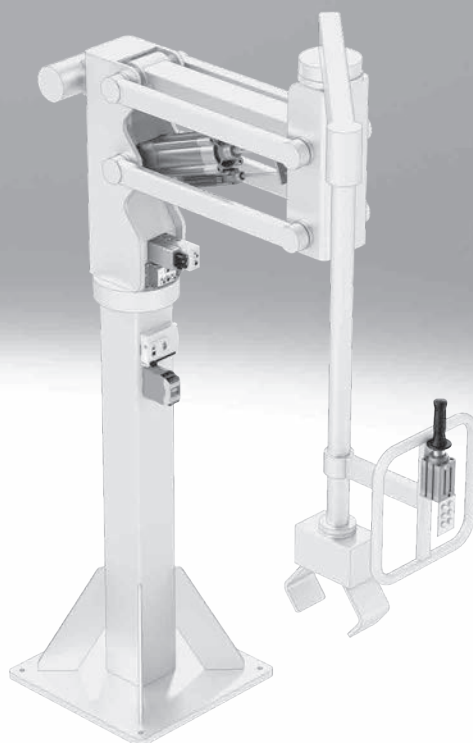

Key features

At a glance

The balancer kit moves loads of up to 999 kg effortlessly at the touch of a finger. The controller automatically detects the weight of the load and sets the balancing force itself. It also takes into account weight changes in the suspended state. This is helpful in keeping production processes really flexible. The components of the balancer kit are suitable for installation in all common kinematic systems such as lifting columns or parallel kinematic systems.

Two packages can be selected:

Basic package

- Single-channel speed monitoring
- Safety: Performance Level b achievable
- Safely limited speed (SLS)
- Safe stopping and closing (SSC)

Package with safety relay unit

- Dual-channel speed monitoring
- Safety: Performance Level d achievable
- Safely limited speed (SLS)
- Safe stopping and closing (SSC)

The following operating modes can be selected:

- Load-controlled mode: moving the load using the control element or optionally directly at the workpiece. The force for moving the workpiece, without using the control element, depends on the friction in the mechanism. Low friction in the mechanism (e.g. in the guide) results in a low actuating force.
- Position-hold mode: moving the load using the control element only. The load is held in this position, even if it changes. In this case, the force of the workpiece is independent of the friction in the mechanism. This is compensated by the control element.

Wide range of applications

For applications in all industry segments where heavy loads need to be moved in defined, repeated sequences.

Areas of application:

- Loading and unloading
- Stacking and destacking
- Rotating, swivelling, tilting and emptying containers
- Assembly in production lines
- Loading goods



Key features

Modular application software for configuration, operation and visualisation

- The application is commissioned via a web interface, which is also used for configuring the application-specific functions
- No programming skills are required to use the pre-installed, ready-to-use software
- The program sequence itself is controlled by variables and digital control inputs, e.g. by the higher-order controller
- All process data can be interchanged individually with the host system

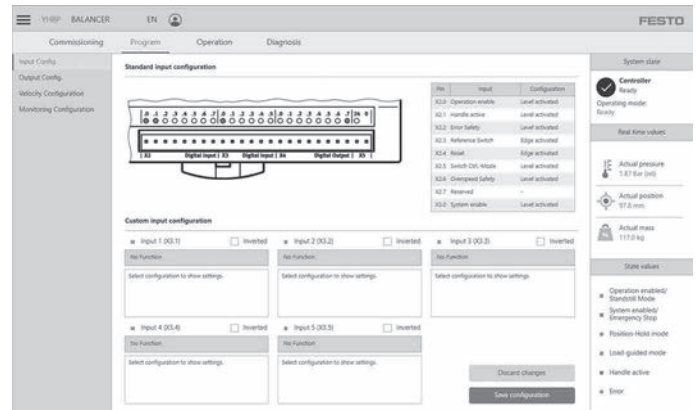

The following software functions are available

Commissioning	Configuration	Operation	Diagnostics
<ul style="list-style-type: none"> • Configuring the hardware • Teaching end positions • Adjusting control parameters • Testing the shut-off valves 	User-defined configuration of inputs and outputs with: <ul style="list-style-type: none"> • Prepositioning • Speed selection • Sensing of load and position ranges • Display of operating mode 	Creating trace data such as: <ul style="list-style-type: none"> • Pressure • Position • Load • Speed 	<ul style="list-style-type: none"> • Diagnostics of system components • Display of error messages • Reading from error memory

Software functions	
Number of configurable inputs	5
Number of configurable outputs	3
Number of saved errors	Max. 40
Configuration export	Via FTP
Interface to host system	Modbus TCP

System components

Included in the scope of delivery of the balancer kit

System component	Description
Standards-based cylinder DSBG	



- Standards-based cylinder, provides the force for moving the payload
- Piston \varnothing 50 ... 125 mm: Stroke range 100 ... 1990 mm
- Piston \varnothing 160 and 200 mm: Stroke range 100 ... 1000 mm
- Theoretical force at 6 bar:
Advancing: 1178 ... 18850 N
Retracting: 990 ... 18096 N
- Up to piston \varnothing 125 mm and stroke < 1000 mm:
with feature DSBG-...-L1 (low friction for balancer applications)

Displacement encoder DNCI-32



- For recording position and speed
- For applications with Performance Level b: one measuring head (single-channel)
- For applications with Performance Level d: two measuring heads (dual-channel)

Valve unit VPCB



- Valve block comprising:
Balancer valve VPCB – 3/3-way proportional pressure regulator with special pressure control and shut-off valve actuation as well as two shut-off valves designed as 2/2-way valves
- Diagnostic display for fast error detection
- For applications with Performance Level d: with switching position sensing for the shut-off valves

Balancer controller CECC-D-BA



- Balancer controller for actuating and locking the balancer with pre-installed software (browser-based web visualisation for commissioning and diagnostics)

Sensor interface CASB



- Converts the signal from the displacement encoder into a readable signal for the safety relay unit

Control element VAOH



- Ergonomically designed handle for operating the balancer
- The movement of the handle in axial direction produces a positive or negative pressure in the chambers. These differences in pressure are used to control the balancer. Springs in the respective chambers reset the balancer to the centre position

Safety relay unit PNOZS30C24-240VACDC



- Device for speed monitoring. In the event of an error, the compressed air in the cylinder is shut off in two channels and the system is braked. The same happens in the event of a power failure

System components

Can be ordered as accessories

System component
Service unit



Comprising:

- Manual on/off valve
- Filter regulator
- Wall mounting plate
- Pressure gauge
- Lockable regulator head
- Plastic bowl with plastic bowl guard
- Manual condensate drain
- Flow direction from left to right

Max. output pressure: 12 bar
Grade of filtration: 5 µm

Connector set VABS

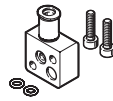

For external pressure measurement.
When using this, the sub-base at the valve unit must be replaced (see operating instructions)

Foot mounting for standards-based cylinder DSBG



→ Page 20

Swivel flange for standards-based cylinder DSBG

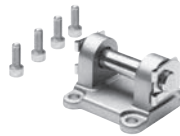

→ Page 21

Swivel flange for standards-based cylinder DSBG



→ Page 22

Rod clevis for standards-based cylinder DSBG



→ Page 22

Foot mounting for displacement encoder DNCI-32



→ Page 20

Swivel flange for displacement encoder DNCI-32



→ Page 21

Swivel flange for displacement encoder DNCI-32



→ Page 22

Self-aligning rod coupler for displacement encoder DNCI-32



→ Page 22

Rod eye for displacement encoder DNCI-32



→ Page 22

Inscription labels for sensor interface CASB



→ Page 22

System components

Mounting variants

When configuring the balancer kit, there is a choice of three different mounting solutions for the components. Depending on the selection, the individual components are mounted in a control cabinet or on a mounting plate, or supplied as individual components.

Via control cabinet

In this case, the following components are installed in the control cabinet:

- Main switch
- Power supply unit
- Balancer controller
- Terminals

Via mounting plate

In this case, the following components are mounted on a mounting plate:

- Power supply unit
- Balancer controller
- Terminals

Individual solution

In this case, the individual parts are packed and supplied loose.

Optionally with safety relay unit

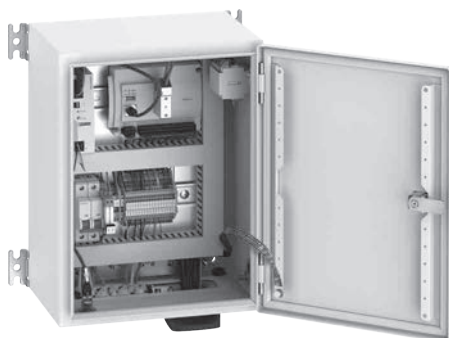

Optionally with safety relay unit

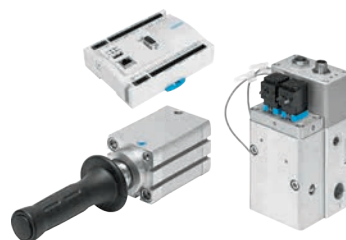

Scope of delivery of balancer kit

Designation	Type	Basic package	Package with safety relay unit
Standards-based cylinder	DSBG-...	■	■
Displacement encoder	DNCI-32-... (with one measuring head)	■	-
	DNCI-32-... (with two measuring heads)	-	■
Valve unit	VPCB-6-L-8-G38-10-F-D3-T22	■	-
	VPCB-6-L-8-G38-10-F-D3-T22-M	-	■
Control element	VAOH-P15-H13	■	■
Plug socket with cable	KME-1-24DC-5-LED	■	■
Connecting cable	NEBC-M12G5-ES-5-LE5-CO	■	■
Balancer controller	CECC-D-BA	■	■
Plug	NECC-L2G24-C1	■	■
Plug	NECC-S1G9-C2-M	■	■
Proximity switch	SMT-8M-A-PS-24V-E-0,3-M8D	■	■
Sensor interface	CASB-MT-D3-R7	-	■
Connecting cable	KM12-8GD8GS-2-PU	-	■
Connecting cable	NEBU-M12G5-K-5-LE4	-	■
Plug socket with cable	NEBU-M12W8-K-5-N-LE8	-	■
Safety relay unit	PNOZS30C24-240VACDC	-	■

Key features

Ordering via the configurator

It is very easy to configure and order a wide range of balancer kits using the configurator.

The "Configuration", "Preassembly" and "Accessories" tabs are used to select the combinations and display them with the correct configuration. CAD files and ePLAN macros are included.

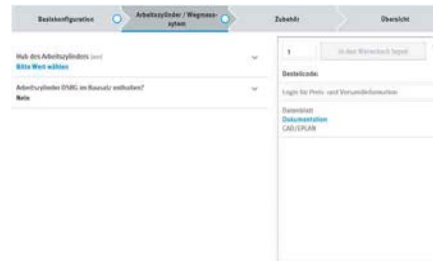
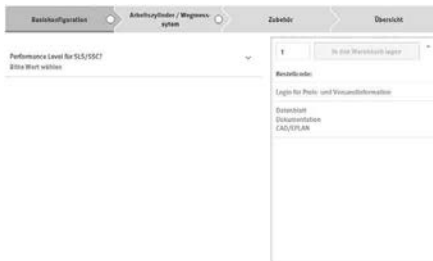

Ordering data – Product options

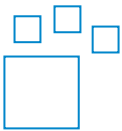

Configurable product
This product and all its product options can be ordered using the configurator.

The configurator can be found under Products on the DVD or at
→ www.festo.com/catalogue/...

Part no. **8087218**
Type **YHBP**

Optional: Ordering the control cabinet

The following part numbers can also be used to order the control cabinet/mounting plate separately.

Ordering data	Part no.	Type
Description		
Control cabinet with safety relay unit (Performance Level d)	8118454	CMCB-D1-CC-S1
Mounting plate with safety relay unit (Performance Level d)	8118455	CMCB-D1-C-S1
Control cabinet without safety relay unit (Performance Level b)	8118456	CMCB-D1-CC-S0
Mounting plate without safety relay unit (Performance Level b)	8118457	CMCB-D1-C-S0

Data sheet

General technical data

Stroke range		
For piston \varnothing 50 ... 125 mm	[mm]	100 ... 1990
For piston \varnothing 160 and 200 mm	[mm]	100 ... 1000
Piston \varnothing	[mm]	50 ... 200
Theoretical force at 6 bar		
Advancing	[N]	1178 ... 18850
Retracting	[N]	990 ... 18096
Load mass ¹⁾ at ratio $i=1:1$	[kg]	25 ... 999
Transmission ratio of kinematics		
For lifting columns		1:1
For parallel kinematic systems		1:1 ... 1:5
Weight		
Overall weight	[g]	4800 ... 60500
Standards-based cylinder weight	[g]	→ www.festo.com/dsbg
Displacement encoder weight	[g]	→ www.festo.com/dnci
Valve unit	[g]	1550
Balancer controller	[g]	200
Control element	[g]	1350
Sensor interface	[g]	300

1) Load mass = kinematic system + gripper tool + workpiece

Electrical data

Operating voltage range	[V DC]	21.6 ... 26.4
Residual ripple	[%]	5
Nominal operating voltage	[V DC]	24
Current consumption with load-free outputs	[A]	2
Duty cycle	[%]	100
Max. electrical power consumption	[W]	48
Reverse polarity protection		For operating voltage

Data sheet

Operating and environmental conditions		
Ambient temperature		
With Performance Level b	[°C]	0 ... +40
With Performance Level d	[°C]	0 ... +50
Storage temperature	[°C]	-20 ... +70
Degree of protection		
For valve unit VPCB		IP65
For balancer controller CECC-D-BA		IP20
Duty cycle	[%]	100
Certification		RCM compliance mark
CE marking (see declaration of conformity)		To EU EMC Directive ¹⁾
Note on materials		RoHS-compliant
		Contains paint-wetting impairment substances

1) For information about the area of use, see the EC declaration of conformity at: www.festo.com/sp → Certificates.
If the devices are subject to usage restrictions in residential, commercial or light-industrial environments, further measures for the reduction of the emitted interference may be necessary.

Mass m as a function of transmission ratio i and cylinder diameter \varnothing

Minimum load at 6 bar

Maximum load at 6 bar

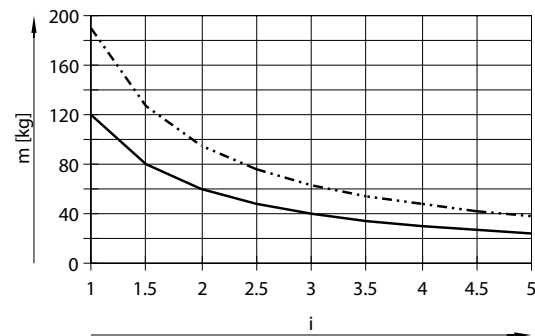
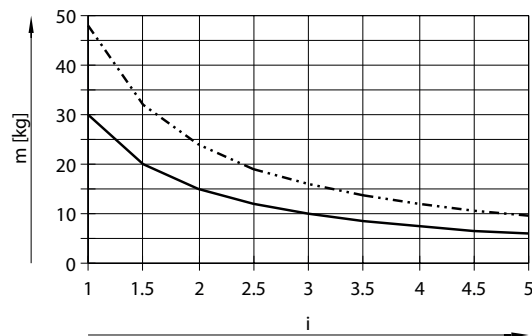

— YHBP-50
- - - YHBP-63

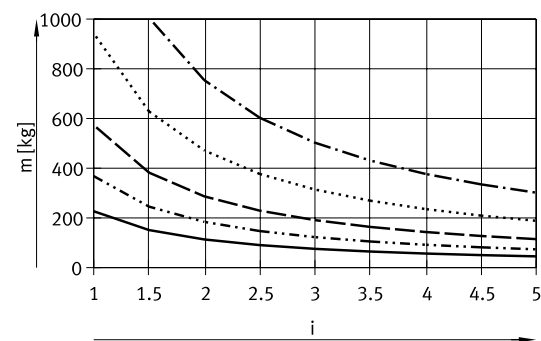
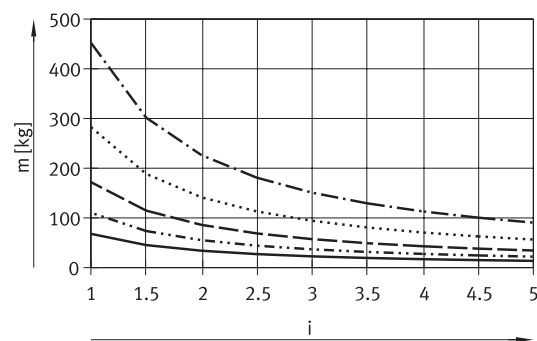

— YHBP-80
..... YHBP-100
- - - YHBP-125
- · - · YHBP-160
- - - - YHBP-200

Data sheet

Technical data – Displacement encoder system DNCI-32

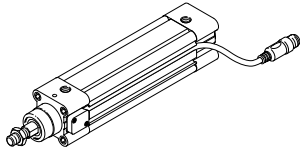

DNCI-32-...: with one measuring head
 DNCI-32-...-BA: with two measuring heads

Mechanical data

Measuring principle		Encoder, contactless and relative measurement
Stroke ¹⁾	[mm]	100 ... 1990
Resolution	[mm]	0.01
Repetition accuracy	[mm]	≤ ±0.5
Output signal		Analogue
Linearity error		
Strokes up to 500 mm	[mm]	≤ ±0.08
Strokes up to 1000 mm	[mm]	≤ ±0.09
Max. travel speed	[m/s]	1.5
Maximum permitted magnetic interference field ²⁾	[kA/m]	10
Cable length ³⁾	[m]	1.5
Electrical connection		Cable with 8-pin plug, round design, M12
Type of mounting		With accessories
Mounting position		Any
Materials		
Housing		Anodised aluminium
Cover		Die-cast aluminium
Seals		TPE-U
Sensor housing		Polyacetal
Note on materials		RoHS-compliant

1) Due to its design, the displacement encoder is 10 mm longer than the selected cylinder.

2) At a distance of 100 mm

3) The cable length must not be changed.

Operating and environmental conditions

Ambient temperature	[°C]	-20 ... +80
Vibration resistance to DIN/IEC 68, Part 2-6		Severity level 2
Shock resistance to DIN/IEC 68, Part 2-82		Severity level 2

Data sheet

Technical data – Valve unit VPCB

Without switching position display

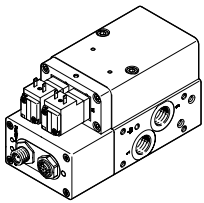

With switching position display

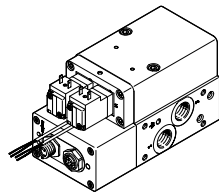

Mechanical data

Pneumatic connection		
1, 2, 3		G3/8
H		G1/8
Standard nominal flow rate	[l/min]	725
Nominal width	[mm]	6
Valve function		3-way proportional flow control valve
Design		Piston spool with integrated pressure sensors
Sealing principle		Hard
Actuation type		Electrical
Reset method		Magnetic spring
Type of control		Direct
Flow direction		Non-reversible
Short circuit current rating		Yes
Reverse polarity protection		For operating voltage
Diagnostic function		Display via LED
Typical lowering speed ¹⁾	[mm/s]	15
Fieldbus interface		
Log		CAN bus with Festo protocol
Connection technology		M12x1, A-coded to EN 61076-2-101
Max. CAN bus cable length	[m]	30

1) When the manual exhaust is operated, with piston diameter 80 mm, transmission ratio 1:1 and load mass of 100 kg.

Electrical data

Operating voltage range	[V DC]	21.6 ... 26.4
Nominal operating voltage	[V DC]	24
Duty cycle	[%]	100
Proportional directional control valve		
Residual ripple	[%]	5
Current consumption (short term)	[A]	1.2
Current consumption (typical)	[mA]	120
Power consumption	[W]	33.5
Reverse polarity protection		For operating voltage
Shut-off valve		
Current consumption	[mA]	62
Power consumption	[W]	1.5

Operating and environmental conditions

Operating pressure	[bar]	4 ... 8
Operating medium		Compressed air to ISO 8573-1:2010 [6:4:4]
Note on the operating/pilot medium		Operation with lubricated medium not possible Max. particle size 5 µm
Vibration resistance		Transport application test with severity level 2 to FN 942017-4 and EN 60068-2-6
Shock resistance		Shock test with severity level 2 to FN 942017-5 and EN 60068-2-27
Materials		
Housing		Anodised wrought aluminium alloy
Seals		FPM, HNBR, NBR
Note on materials		RoHS-compliant

Data sheet

Technical data – Control element VAOH

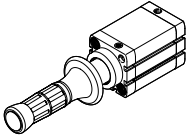

Mechanical data

Piston \varnothing	[mm]	50
Stroke	[mm]	20
Pneumatic connection		G1/8
Max. transverse load	[N]	100
Position sensing		Via proximity switch
Type of mounting		With through-hole
		Via female thread
		With accessories
Mounting position		Any

Operating and environmental conditions

Operating pressure	[bar]	≤ 1
Materials		
Cylinder barrel, end cap		Anodised aluminium
Piston rod		Steel
Note on materials		
		RoHS-compliant
		Contains paint-wetting impairment substances

Mounting options

1 Direct mounting on the bearing cap

2 Through-hole mounting

3 Direct mounting on the end cap

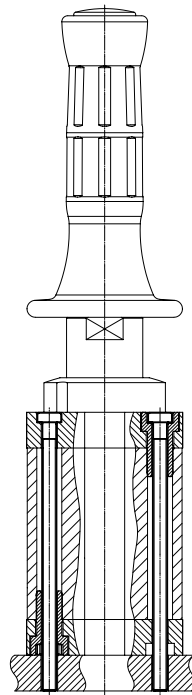
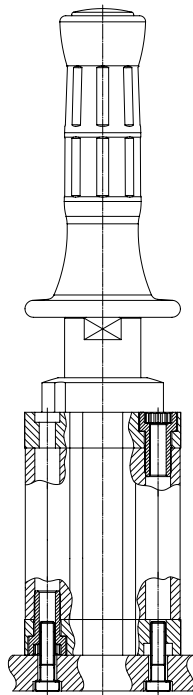
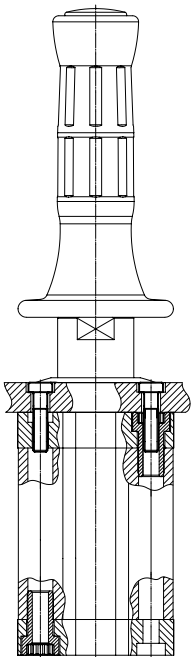

Data sheet

Pin allocation – Balancer controller CECC-D-BA

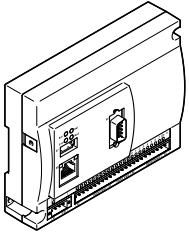

I/O interface for communicating with a higher-order PLC or the control panel

Pin	Connection	Function
X2.0	Inputs	Operation enable
X2.1		Handle active
X2.2		Speed monitor fault input
X2.3		Reference sensor
X2.4		Reset fault
X2.5		Change operating mode
X2.6		Speed monitor signal input
X2.7		Not allocated
X3.0		System enable (emergency off)
X3.1 ... X3.5		User-configured inputs
X4.0	Outputs	Operation enabled
X4.1		Freely configurable
X4.2		Shut-off valve 1
X4.3		Shut-off valve 2
X4.4		Error
X4.5		Freely configurable
X4.6		Freely configurable
X4.7		System active and ready

Data sheet

Dimensions

Download CAD data → www.festo.com

Standards-based cylinder DSBG-80 ... 125

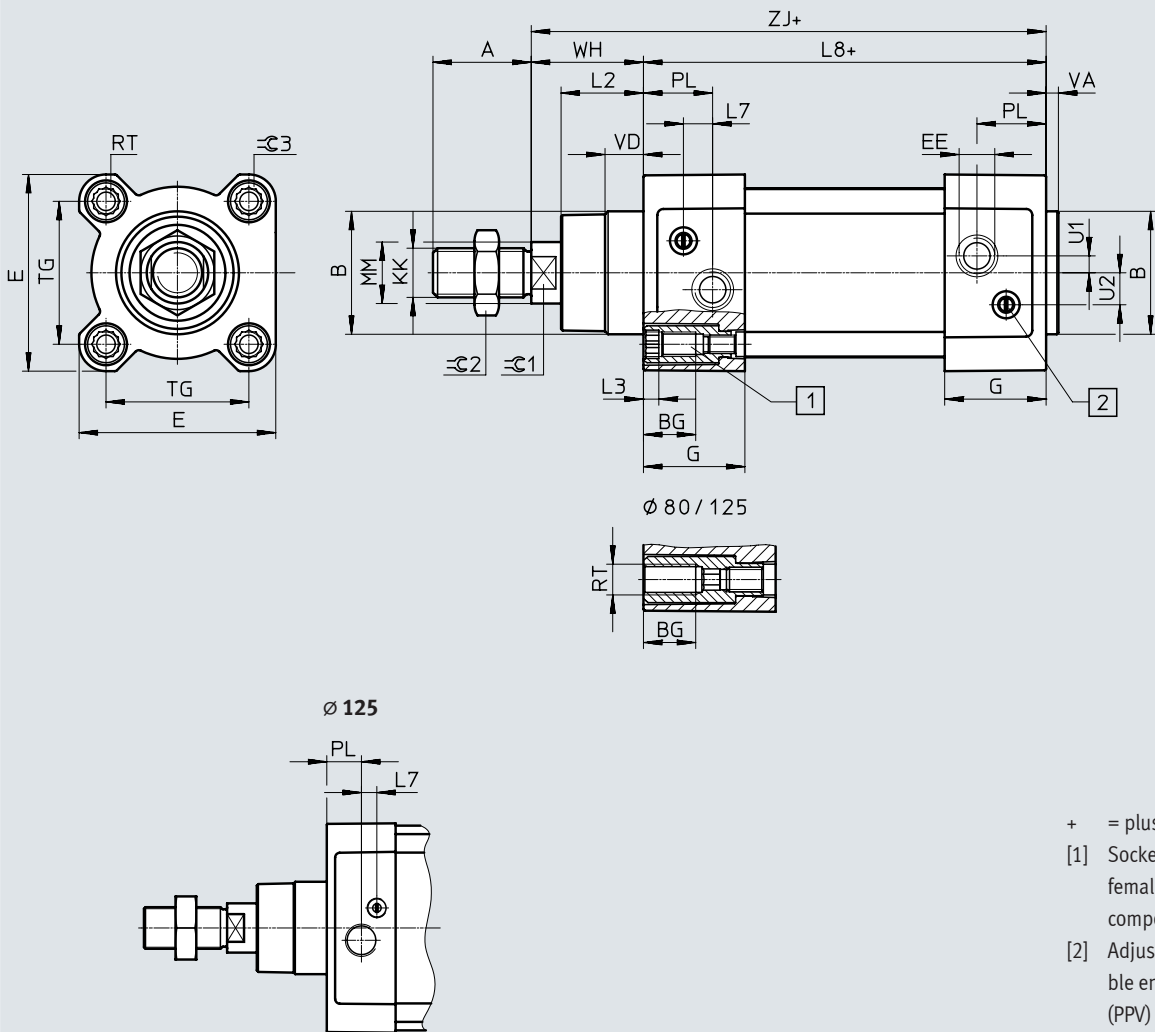

- + = plus stroke length
- [1] Socket head screw with female thread for mounting components
- [2] Adjusting screw for adjustable end-position cushioning (PPV)

Data sheet

∅ [mm]	A -0.5	B ∅ d11	BG min.	E +0.5	EE	G -0.2	L2	L3 max.
50	32	40	16	64	G1/4	33	26.8 _{-0.2}	5
63	32	45	16	75	G3/8	40.5	27 _{-0.2}	5
80	40	45	17	93	G3/8	43	34.2 _{-0.2}	-
100	40	55	17	110	G1/2	48	38 _{-0.2}	-
125	54	60	20	136	G1/2	44.7	45 _{-0.3}	-

∅ [mm]	L7	L8 ±0.4	MM ∅	PL ±0.1	RT	TG ±0.3	U1 ±0.1	U2 ±0.1
50	9.5	106	20	22.5	M8	46.5	5.5	10.4
63	9	121	20	27.5	M8	56.5	6.25	12.75
80	11	128	25	30	M10	72	8	12.5
100	7.5	138	25	31.5	M10	89	10	13.5
125	10	160	32	22.5	M12	110	8	13

∅ [mm]	VA	VD +0.5	WH +2.2	ZJ +1.8	≅G1	≅G2	≅G3
50	4 _{-0.2}	11.5	35.6	141.8	17	24	8
63	4 _{-0.2}	15	35.9	157.1	17	24	8
80	4 _{-0.2}	15.7	45.4	173.6	22	30	6
100	4 _{-0.2}	19.2	49.3	187.5	22	30	6
125	6 _{-0.3}	20.5	64.1	225	27	41	8

Data sheet

Dimensions

Download CAD data → www.festo.com

Standards-based cylinder DSBG-160 ... 200

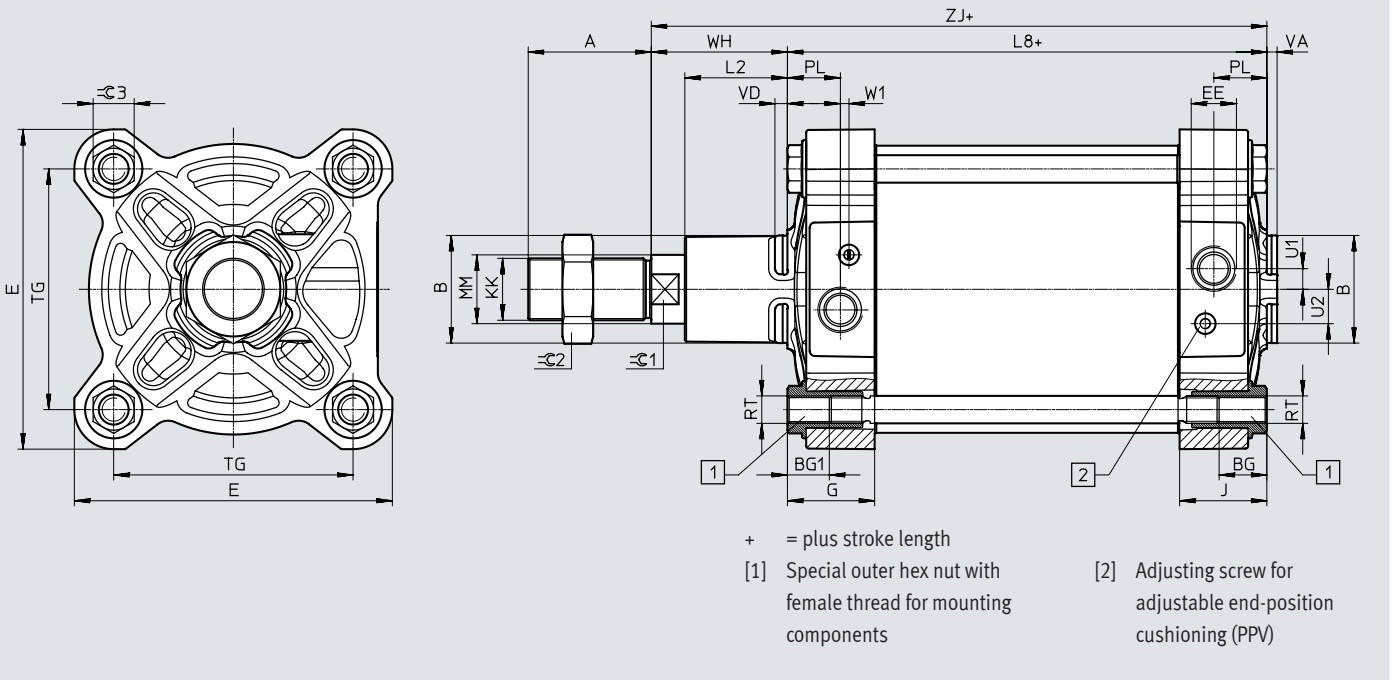

∅	A	B	BG	BG1	E	EE	G	J
[mm]	-0.5	∅ d11	min.	±0.5	±0.9			
160	72	65	24	25	186	G3/4	50.7	50.7
200	72	75	24	25	230	G3/4	46.9	46.7

∅	KK	L2	L8	MM	PL	RT	TG	U1
[mm]	DSBG-... -M...						±1.1	
160	M36x2 M36	60	180±1	40	31	M16	140	12
200	M36x2 M36	70	180±1.2	40	30	M16	175	12

∅	U2	VA	VD	W1	WH	ZJ	∅C1	∅C2	∅C3
[mm]		-1				±1			
160	20	6	7	5	80±1.3	260	36	55	24 _{h13}
200	20	6	6.5	5	95±1.4	275	36	55	24 _{h13}

Data sheet

Dimensions

Download CAD data → www.festo.com

Displacement encoder with one measuring head DNCI-32-...

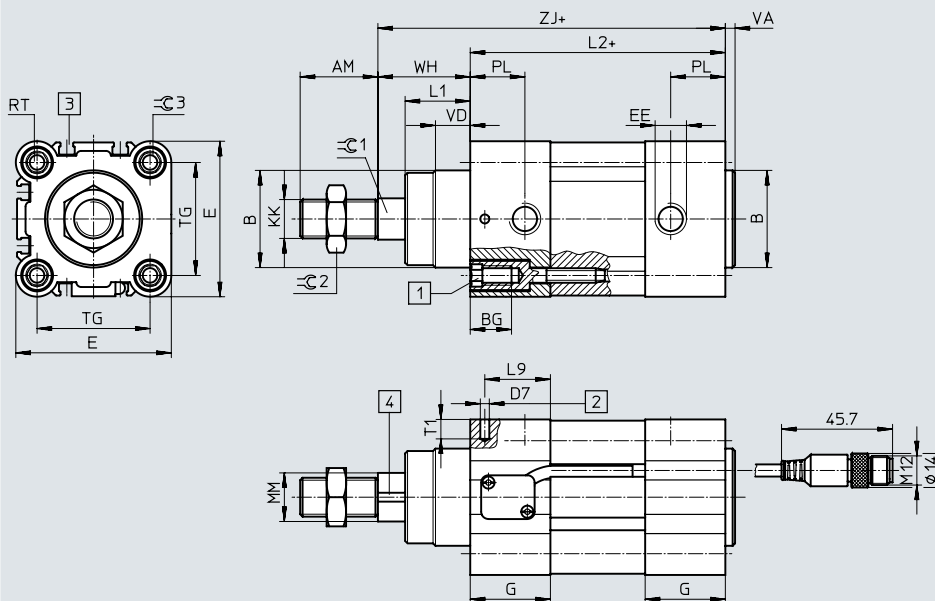

- [1] Special outer hex nut with female thread for mounting components
 - [2] Hole for securing the earthing for self-tapping M4 screw according to DIN 7500
 - [3] Sensor slot for proximity switch SME/SMT-8
 - [4] Magnetic measuring tape
- + = plus stroke length
 ++ = plus 2x stroke length

Type	AM	B ∅ d11	BG	D7 ∅	E	EE	G	KK	L1	L2	L9
DNCI-32-...	22	30	16	3.7	45	G1/8	28	M10x1.25	18	94	22.5

Type	MM ∅ f8	PL	RT	T1	TG	VA	VD	WH	ZJ	⊖1	⊖2	⊖3
DNCI-32-...	12	15.6	M6	8	32.5	4	10	26	120	10	16	6

Displacement encoder with two measuring heads DNCI-32-...

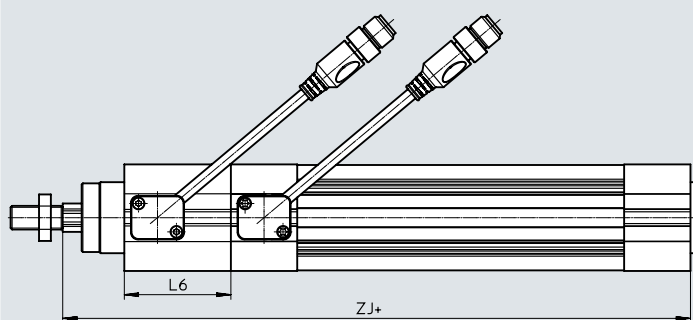

Type	L6	ZJ+
DNCI-32-...	45	165

Data sheet

Dimensions

Download CAD data → www.festo.com

Valve unit VPCB

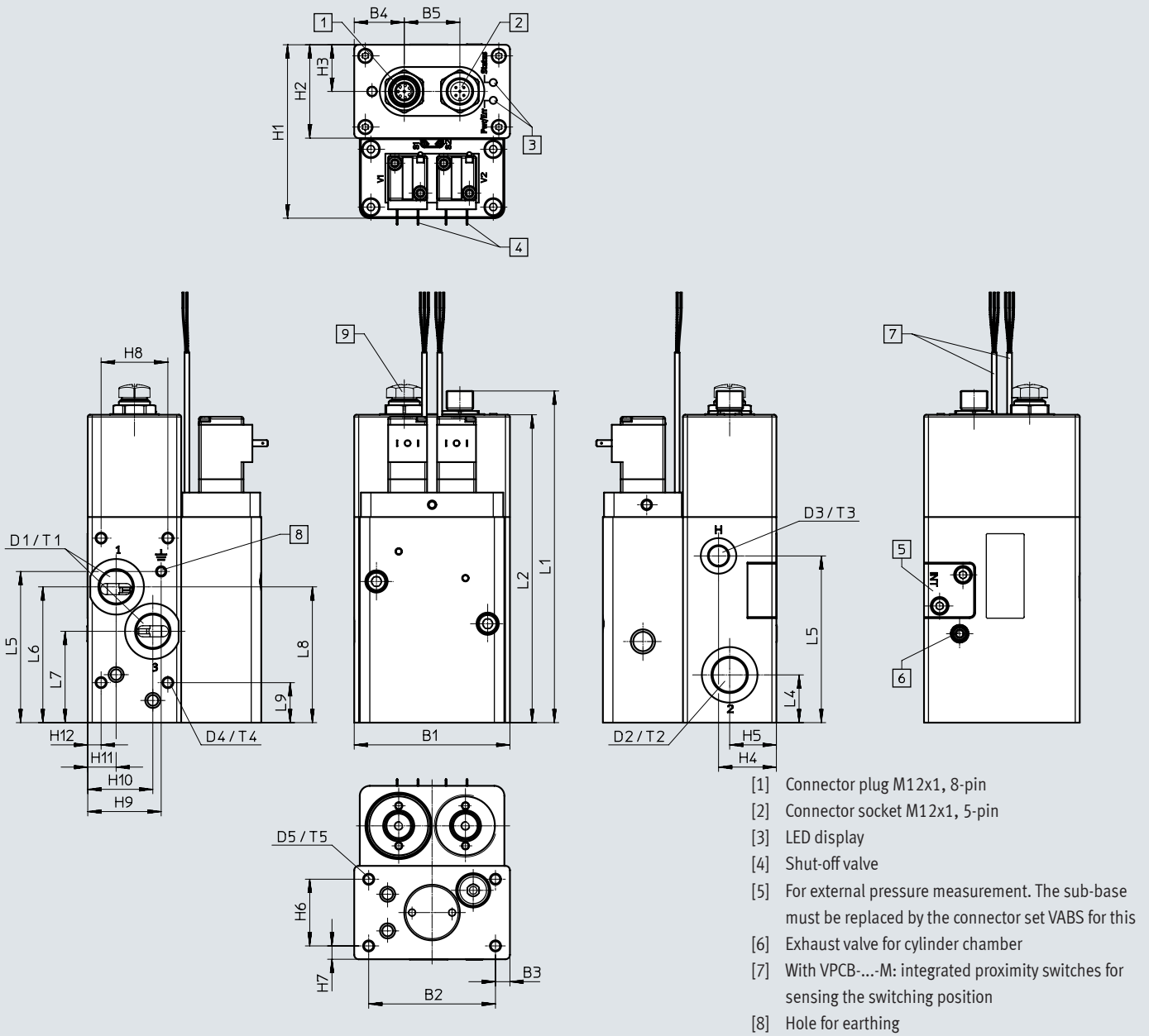

Type	B1	B2	B3	B4	B5	D1	D2	D3	D4	D5	H1	H2
VPCB-...	70	57	7.5	22.5	25	G3/8	G3/8	G1/8	M5	M5	78	42
Type	H3	H4	H5	H6	H7	H8	H9	H10	H11	H12	L1	L2
VPCB-...	21	26	21	30	6	30	33	29.3	12.8	6	149.2	138.5
Type	L3	L4	L5	L6	L7	L8	L9	T1	T2	T3	T4	T5
VPCB-...	75	21.5	68	61.1	41.1	65	18	10	10	8	10	10

Data sheet

Dimensions

Download CAD data → www.festo.com

Control element VAOH

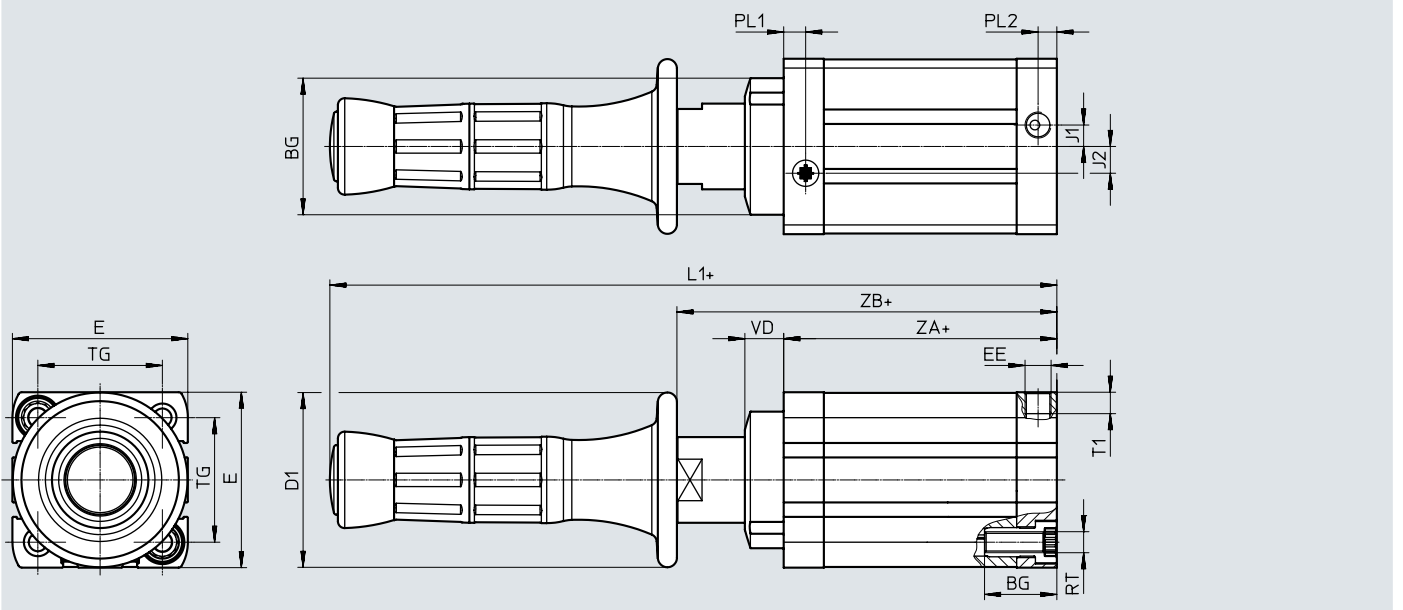

Type	B ∅	BG	D1 ∅	E	EE	J1	J2	L1
VAOH-...	51	27	65	65.5	G1/8	8	10	271.5

Type	PL1	PL2	RT	T1	TG	VD	ZA	ZB ¹⁾
VAOH-...	8.2	7	M8	8	46.5	14.5	102	142

1) +/- 10 mm stroke

Accessories

Foot mounting HNC

Material:
HNC: Galvanised steel
Free of copper and PTFE

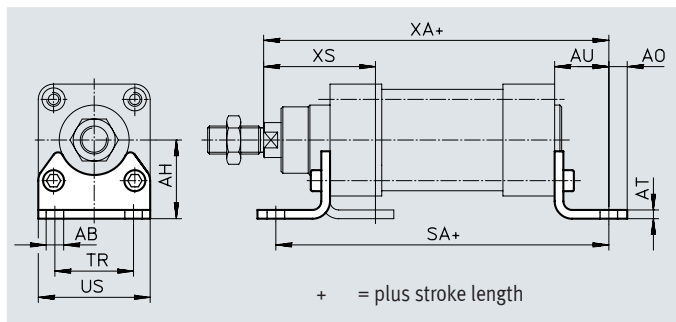

Dimensions and ordering data

For \varnothing [mm]	AB \varnothing	AH	AO	AT	AU	SA	TR	US	XA	XS	Weight [g]	Part no.	Type
32	7	32	6.5	4	24	142	32	45	144	46	144	174369	HNC-32
50	10	45	9.5	5	32	170	45	64	174	63	353	174371	HNC-50
63	10	50	12.5	5	32	185	50	75	189	63	436	174372	HNC-63
80	12	63	15	6	41	210	63	93	215	81	829	174373	HNC-80
100	14.5	71	17.5	6	41	220	75	110	230	86	1009	174374	HNC-100
125	16.5	90	22	8	45	250	90	131	270	102	1902	174375	HNC-125

Foot mounting HNG

Material:
Galvanised steel
Free of copper and PTFE

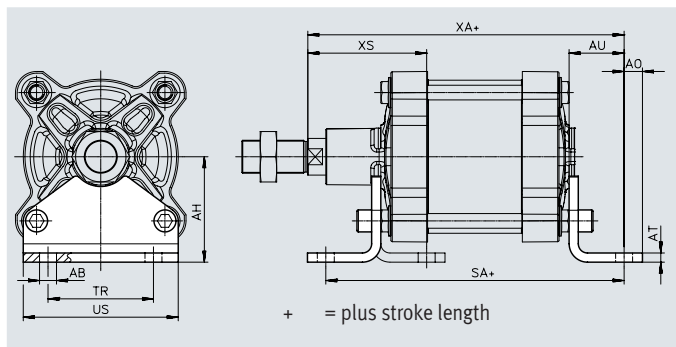

Dimensions and ordering data

For \varnothing [mm]	AB \varnothing	AH	AO	AT	AU	SA	TR	US	XA	XS	Weight [g]	Part no.	Type
160	18.5	115	20	10	60	300	115	169	320	130	3931	34476	HNG-160
200	24	135	30	12	70	320	135	214	345	153	6896	34477	HNG-200

Accessories

Swivel flange SNCB

Material:
Die-cast aluminium
Free of copper and PTFE
RoHS-compliant

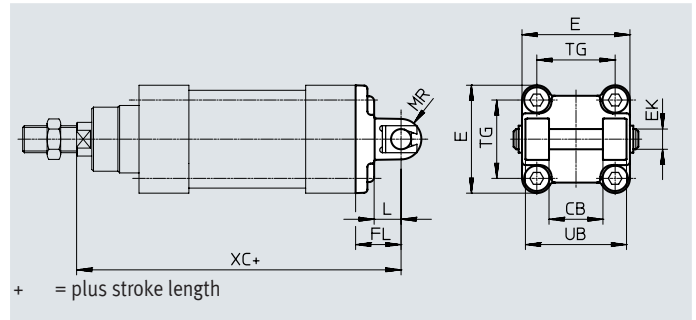

Dimensions and ordering data												
For \varnothing	CB	E	EK \varnothing	FL	L	MR	TG	UB	XC	Weight	Part no.	Type
[mm]	H14	H9/e8	e8	± 0.2		-0.5		h14		[g]		
50	32	64 _{-0.6}	12	27	16	12	46.5	60	169	232	174392	SNCB-50
63	40	75 _{-0.6}	16	32	21	16	56.5	70	189	375	174393	SNCB-63
80	50	93 _{-0.8}	16	36	22	16	72	90	210	636	174394	SNCB-80
100	60	110 _{+0.3/-0.8}	20	41	27	20	89	110	230	1035	174395	SNCB-100
125	70	131 _{-0.8}	25	50	30	25	110	130	275	1860	174396	SNCB-125

Swivel flange SNGB

Material:
 $\varnothing 160$: Die-cast aluminium
 $\varnothing 200$: Galvanised steel
Free of copper and PTFE
RoHS-compliant

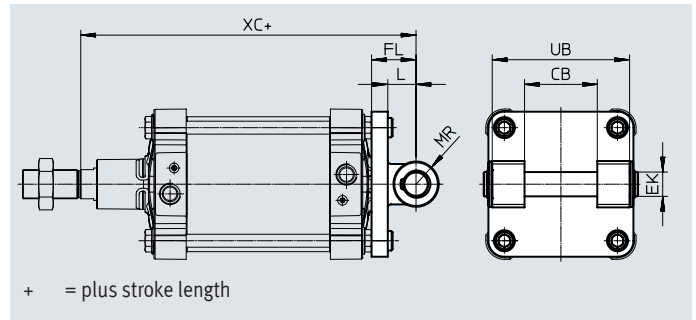

Dimensions and ordering data											
For \varnothing	CB \varnothing	EK \varnothing	FL	L	MR	UB	XC	Weight	Part no.	Type	
[mm]	H14	E10	± 0.2			h14		[g]			
160	90	30	55	37	30	170	315	3445	34547	SNGB-160	
200	90	30	60	40	25	170	335	10020	562455	SNGB-200-B	

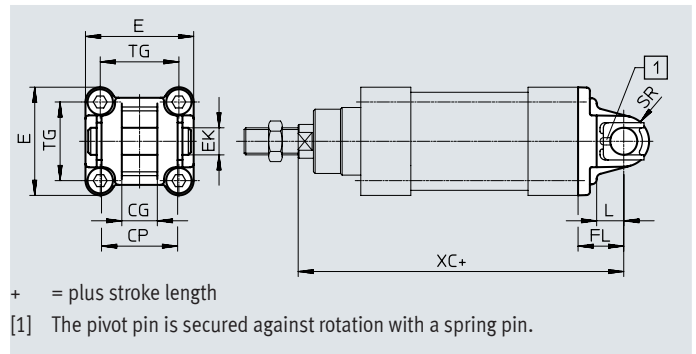

Swivel flange SNC

Material:
Die-cast aluminium
Free of copper and PTFE
RoHS-compliant

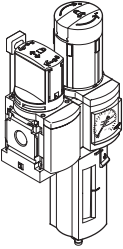
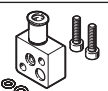
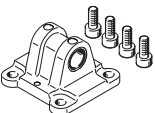
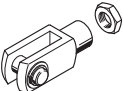
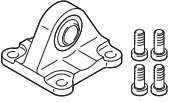
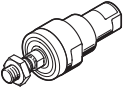

Dimensions and ordering data												
For \varnothing	CG	CP	E	EK \varnothing	FL	L	SR	TG	XC	Weight	Part no.	Type
[mm]	H14	h14		H9	± 0.2					[g]		
32	14	34	45 _{+0.2/-0.5}	10	22	13	10	32.5	142	93	174383	SNC-32

Accessories

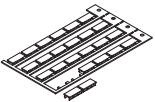
Ordering data	Description	Part no.	Type
Service unit			
	Comprising: <ul style="list-style-type: none"> • Manual on/off valve • Filter regulator • Wall mounting plate • Pressure gauge • Lockable regulator head • Plastic bowl with plastic bowl guard • Manual condensate drain • Flow direction from left to right Max. output pressure: 12 bar Grade of filtration: 5 µm	542280	MSB6-1/2:C3J3-WP
Connector set VABS			
	For external pressure measurement. When using this, the sub-base at the valve unit must be replaced (see operating instructions)	8070953	VABS-P15-S-B6
Swivel flange for standards-based cylinder DSBG			
	For piston ø 50	174406	SNCL-50
	For piston ø 63	174407	SNCL-63
	For piston ø 80	174408	SNCL-80
	For piston ø 100	174409	SNCL-100
	For piston ø 125	174410	SNCL-125
	For piston ø 160	151534	SNGL-160
	For piston ø 200	151535	SNGL-200
Rod clevis for standards-based cylinder DSBG			
	For piston ø 50, 63	6145	SG-M16x1.5
	For piston ø 80, 100	6147	SG-M20x1.5
	For piston ø 125	14987	SG-M27x2-B
	For piston ø 160, 200	9581	SG-M36x2
Swivel flange for displacement encoder DNCI-32			
	For piston ø 32	174397	SNCS-32
Self-aligning rod coupler for displacement encoder DNCI-32			
	For piston ø 32	2305778	CRFK-M10x1.25
Rod eye for displacement encoder DNCI-32			
	For piston ø 32	9261	SGS-M10x1.25
Inscription labels for sensor interface CASB			
	-	18576	IBS-6x10

Festo - Your Partner in Automation



1 Festo Inc.
5300 Explorer Drive
Mississauga, ON L4W 5G4
Canada

Festo Customer Interaction Center
Tel: 1 877 463 3786
Fax: 1 877 393 3786
Email: customer.service.ca@festo.com



2 Festo Pneumatic
Av. Ceylán 3,
Col. Tequesquináhuac
54020 Tlalnepantla,
Estado de México

Multinational Contact Center
01 800 337 8669
ventas.mexico@festo.com



3 Festo Corporation
1377 Motor Parkway
Suite 310
Islandia, NY 11749

Festo Customer Interaction Center
1 800 993 3786
1 800 963 3786
customer.service.us@festo.com



4 Regional Service Center
7777 Columbia Road
Mason, OH 45040

Connect with us



www.festo.com/socialmedia



www.festo.com

Subject to change