













Cylinders with displacement encoder



Cylinders with displacement encoder

Product range overview

Function	Type	Brief description
Drives	Rodless	
	DGCI 	<ul style="list-style-type: none"> • With guide • With contactless displacement measuring encoder • Based on linear drive DGC • Supply ports optionally on end face or front • Wide range of options for mounting on drives • System product for handling and assembly technology
	DGPI/DGPIL 	<ul style="list-style-type: none"> • With or without guide • With contactless displacement measuring encoder, integrated • Wide range of options for mounting on drives • System product for handling and assembly technology
	DGP/DGPL 	<ul style="list-style-type: none"> • With or without guide • With potentiometer or contactless displacement measuring encoder, attached • With clamping unit • Wide range of options for mounting on drives • System product for handling and assembly technology
	With piston rod	
	DNCI 	<ul style="list-style-type: none"> • With contactless displacement measuring encoder • Various piston rod variants • Standards-based cylinder to ISO 15552 <p>    </p>
DNCM 	<ul style="list-style-type: none"> • With attached potentiometer • Various piston rod variants • Standards-based cylinder to ISO 15552 <p>    </p>	
Semi-rotary drive	Swivel module	
	DSMI 	<ul style="list-style-type: none"> • Based on swivel module DSM • Rotary encoder integrated • Compact design • Wide choice of mounting options

Cylinders with displacement encoder

Product range overview

Piston Ø [mm]	Stroke/swivel angle [mm/°]	Suitable			→ Page/Internet
		For positioning with SPC200	For end-position controller SPC11	As a measuring cylinder	
Rodless					
18, 25, 32, 40, 63	100; 160; 225; 300; 360; 450; 500; 600; 750; 850; 1,000; 1,250; 1,500; 1,750; 2,000	■	■	-	42
25, 32, 40, 50, 63	225; 300; 360; 450; 500; 600; 750; 1,000; 1,250; 1,500; 1,750; 2,000	■	■	-	94
25, 32, 40, 50, 63	225; 300; 360; 450; 500; 600; 750; 1,000; 1,250; 1,500; 1,750; 2,000	■	■	■	Drive: 76 Displacement encoder: → Internet: displacement encoder
With piston rod					
32, 40, 50, 63	10 ... 2,000	■	■	■	4
32, 50	100, 160, 200, 250, 320, 400, 500	■	■	■	26
Swivel module					
25, 40	270	■	■	■	130

Standard cylinders DNCI, with integrated displacement encoder

Key features

FESTO

Components for positioning and measuring using the standard cylinder DNCI



Type code

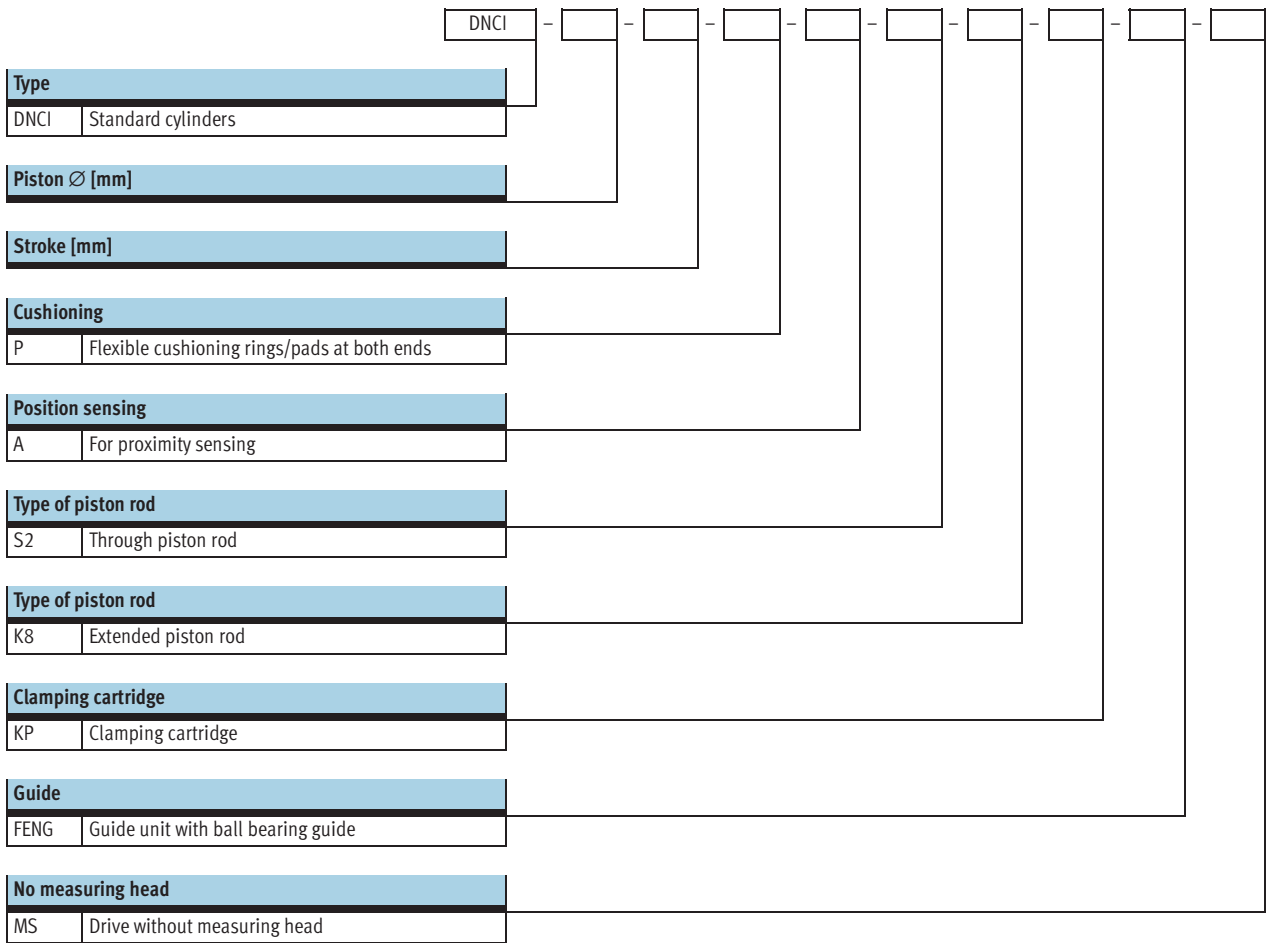

Peripherals overview

Peripherals overview

Technical data

Function

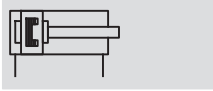
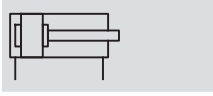

- N- Diameter
32 ... 63 mm
- T- Stroke length
10 ... 2,000 mm



General technical data				
Piston Ø	32	40	50	63
Constructional design	Piston			
	Piston rod			
	Profile barrel			
Mode of operation	Double-acting			
Cushioning	Flexible cushioning rings/pads at both ends			
Position sensing	Integrated displacement encoder			
	For proximity sensing ¹⁾			
Measuring principle (displacement encoder)	Digital			
Type of mounting	Foot mounting			
Torsion protection/Guide ³⁾	Guide rod with yoke, with ball bearing guide			
Stroke	[mm]	100 ... 500		
Piston rod extension	[mm]	1 ... 500		
Pneumatic connection	G1/8	G1/4	G1/4	G3/8
Electrical connection	Cable with 8-pin plug, round type M12			
Cable length	[m]	1.5		

1) Not included in the scope of delivery, can be ordered as an option

3) Guide unit FENG-KF must be ordered as an option and will be supplied attached, the max. stroke is reduced

Forces [N] and impact energy [Nm]				
Piston Ø	32	40	50	63
Theoretical force at 6 bar advancing	483	754	1,178	1,870
	S2 415	633	990	1,682
Theoretical force at 6 bar retracting	415	633	990	1,682
	S2 415	633	990	1,682
Impact energy at end positions	0.1	0.2	0.2	0.5

Permissible impact velocity:

$$v_{\text{perm.}} = \sqrt{\frac{2 \times E_{\text{perm.}}}{m_{\text{dead}} + m_{\text{load}}}}$$

- v_{perm.} Permissible impact velocity
- E_{perm.} Max. impact energy
- m_{dead} Moving load (drive)
- m_{load} Moving work load

Note

These specifications represent the maximum values which can be reached. Note the maximum permitted impact energy.

Maximum permissible load:

$$m_{\text{load}} = \frac{2 \times E_{\text{perm.}}}{v^2} - m_{\text{dead}}$$

Technical data

Operating and environmental conditions	
Operating medium ²⁾	Compressed air, filtered and unlubricated, filter unit 5 µm
Ambient temperature ³⁾	[°C] -20 ... +80
Vibration resistance	To DIN/IEC 68 Parts 2 – 6, severity level 2
Continuous shock resistance	To DIN/IEC 68 Parts 2 – 82, severity level 2
CE symbol (declaration of conformance)	In accordance with EU EMC Directive
Protection class (displacement encoder)	IP65 to IEC 60 529
Corrosion resistance class CRC ⁴⁾	1

- 2) The proportional directional control valve MPYE used requires the characteristic values
 3) Note operating range of proximity sensors
 4) Corrosion resistance class 1 according to Festo standard 940 070
 Components requiring low corrosion resistance. Transport and storage protection. Parts that do not have primarily decorative surface requirements, e.g. in internal areas that are not visible or behind covers.

Weights [g] with displacement encoder				
Piston Ø	32	40	50	63
Basic drive DNCI-...				
Product weight with 0 mm stroke	521	853	1,319	1,914
Additional weight per 10 mm stroke	30	44	62	71
Moving load with 0 mm stroke	95	175	316	383
Additional weight per 10 mm stroke	8	14	23	23
Drive with through piston rod DNCI-...-S2				
Product weight with 0 mm stroke	586	981	1,553	2,165
Additional weight per 10 mm stroke	39	60	87	96
Moving load with 0 mm stroke	155	164	297	364
Additional weight per 10 mm stroke	17	30	48	48
Additional weight with extended piston rod K8				
Additional weight per 10 mm stroke	8	14	23	23
Additional weight with clamping cartridge KP				
Product weight	234	394	700	1,147
Additional weight with guide unit FENG-...				
Product weight with 0 mm stroke	1,530	2,370	4,030	5,410
Additional weight per 10 mm stroke	18	32	50	62

Materials

Sectional view	
Standard cylinders	
1 Piston rod	High-alloy steel
2 Cylinder barrel	Anodised aluminium
3 Bearing/end caps	Die-cast aluminium
- Dynamic seals	Polyurethane TPE-U
- Static seals	Nitrile rubber
- Lubricant	Klüberplex BE31-102
Displacement encoder	
- Sensor housing	Polyacetate
- Cable sheath	Polyurethane
- Plug housing	Polybuteneterephthalate
- Wall mounting plate	Polyacetate
- Screws for mounting plate	Steel

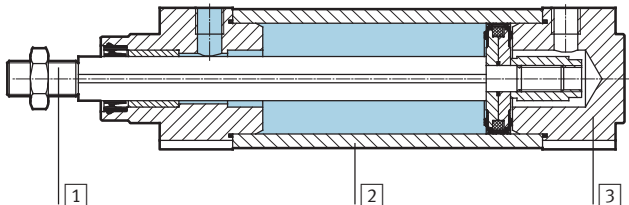

Technical data

Electrical data, displacement encoder		
Linearity error ¹⁾	[mm]	$\pm(0.07 \pm 0.02 \cdot L[m])$
Max. speed of travel	[m/s]	1.5
Ambient temperature	[°C]	-20 ... +80
Max. temperature coefficient	[ppm/°K]	30
Protection class		IP65
CE symbol (declaration of conformance)		In accordance with EU EMC Directive
Max. permitted magnetic disruption field at 100 mm interval from the sensor ²⁾	[kA/m]	10
Electrical connection		Cable with 8-pin plug, round type M12
Cable length	[m]	1.5

- 1) Maximum deviation of the output signal from "best fit" line (characteristic curve with nominal gradient).
L = Length of measuring system in meters
- 2) See also mounting conditions

Technical data

Torques and lateral forces

The piston rod must not absorb any torque. We therefore recommend that an external guide FENG-KF be used with the drive DNCI. The guide unit is delivered installed.

The permissible static and dynamic characteristic load values with and without attached guide as well as with regard to the technical data of the variants (S2, S8, S9)

→ Internet: dnc

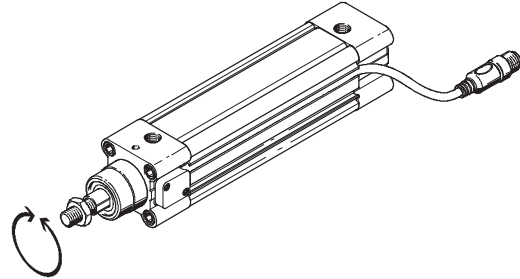

Mounting conditions

When mounting a drive A with magnet (for position sensing), in addition to a standard cylinder DNCI, the following conditions must be observed:

- X Minimum distance between the drives
- Y Offset between the drives on the bearing cap

Parallel assembly

If the offset $Y = 0$ mm, the drives can be assembled directly next to one another.

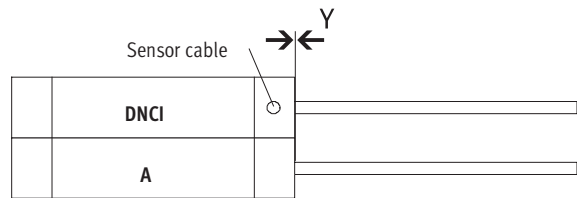

Offset assembly, cable outlet between the drives

If the offset $Y > 0$ mm and the cable outlet is between the drives, the distance from $X > 70$ mm must be observed.

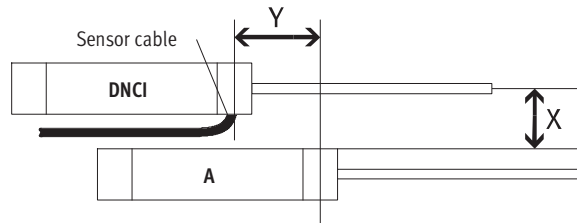

Offset assembly, cable outlet upwards or downwards

If the offset $Y > 0$ mm and the cable outlet is up or down, the distance from $X > 60$ mm must be observed.

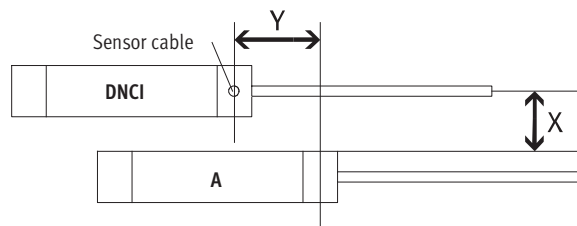

Pin assignment of plug, view of plug

Pin	Function	Colour
1	5 V	black
2	GND	brown
3	sin+	red
4	sin-	orange
5	cos-	green
6	cos+	yellow
7	Screening	Screening
8	-	-

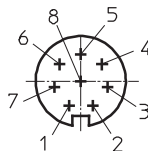

technical data

Dimensions

Download CAD Data → www.festo.com/us/cad

Basic version

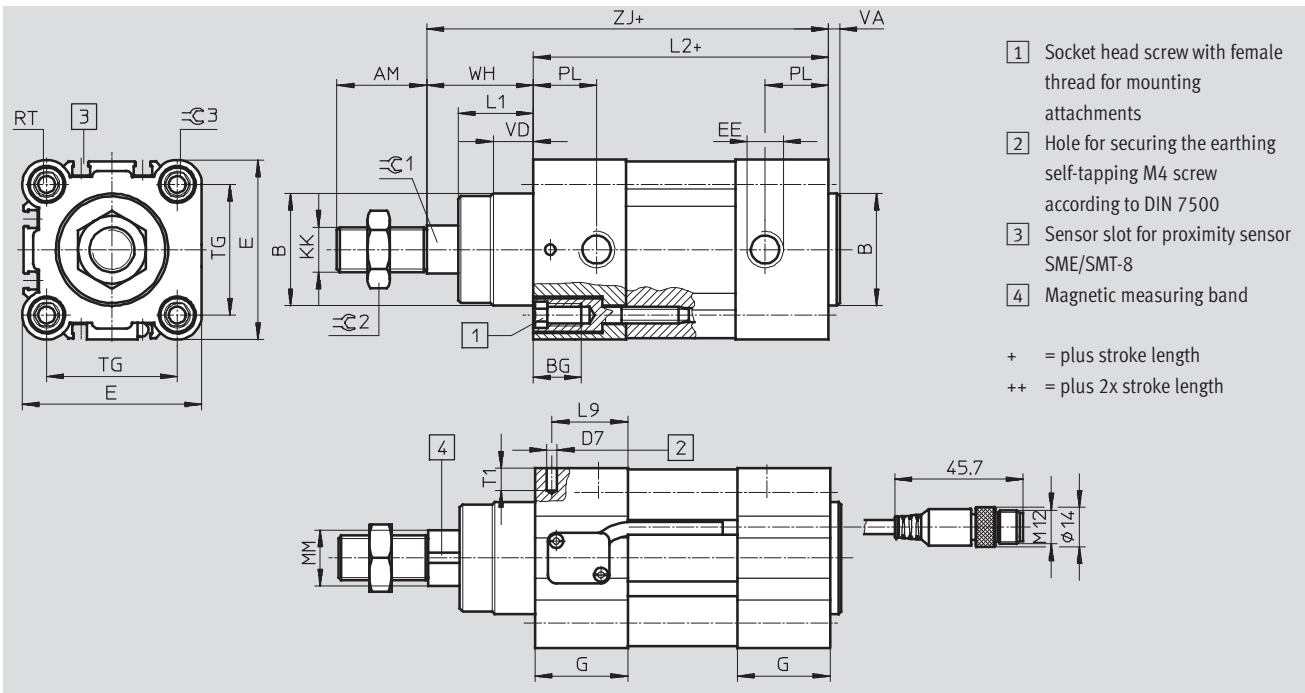

S2 – Through piston rod

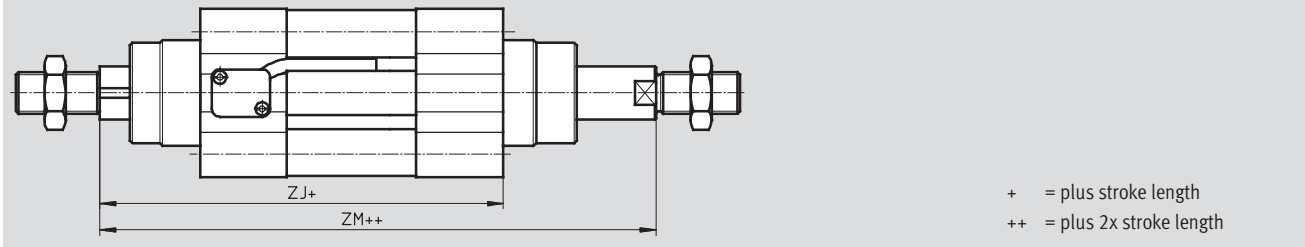

S2 / KP – Through piston rod with clamping cartridge

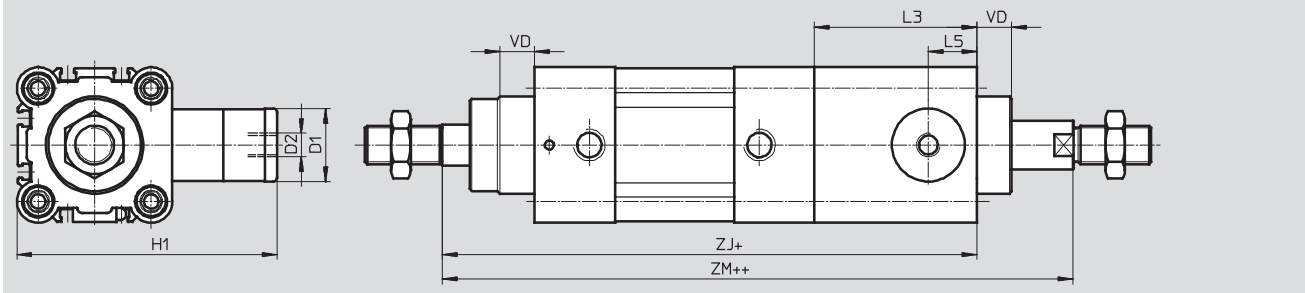

K8 – Extended piston rod

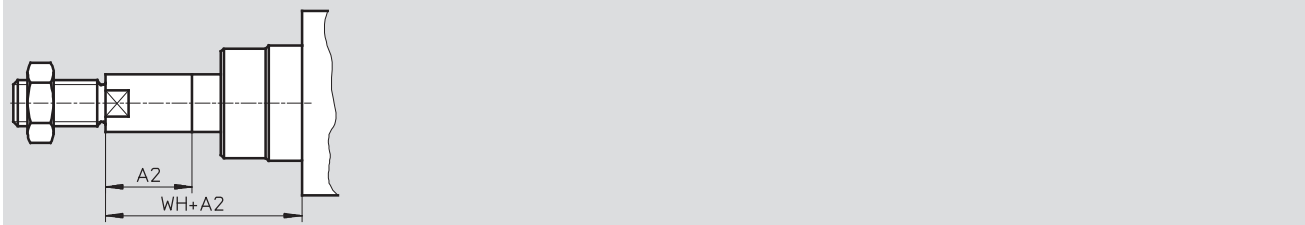

Technical data

Ø	AM	A2 max.	B	BG	D1	D2	D7	E	EE	G	H1
[mm]			Ø d11		Ø f9		Ø				
32	22	500	30	16	20	M5	3.7	45	G ¹ / ₈	28	67
40	24	500	35	16	24	G ¹ / ₈	3.7	54	G ¹ / ₄	33	88
50	32	500	40	17	30	G ¹ / ₈	3.7	64	G ¹ / ₄	33	107

63	32	500	45	17	38	G1/8	3.7	75	G3/8	40.5	123
----	----	-----	----	----	----	------	-----	----	------	------	-----

∅	KK	L1	L2	L3	L5	L9	MM ∅ f8	PL	RT	T1	TG
[mm]											
32	M10x1.25	18	94	45	14	22.5	12	15.6	M6	8	32.5
40	M12x1.25	21.3	105	53	16	27	16	14	M6	8	38
50	M16x1.5	26.8	106	67	20	27	20	14	M8	8	46.5
63	M16x1.5	27	121	76	24	33	20	17	M8	8	56.5

∅	PI	VD	WH	ZJ		ZM		≈C1	≈C2	≈C3
[mm]					KP		KP			
32	4	10	26	120	165	148	193	10	16	6
40	4	10.8	30	135	188	167	220	13	18	6
50	4	14.3	37	143	210	183	250	17	24	8
63	4	14.5	37	158	234	199	275	17	24	8

Technical data

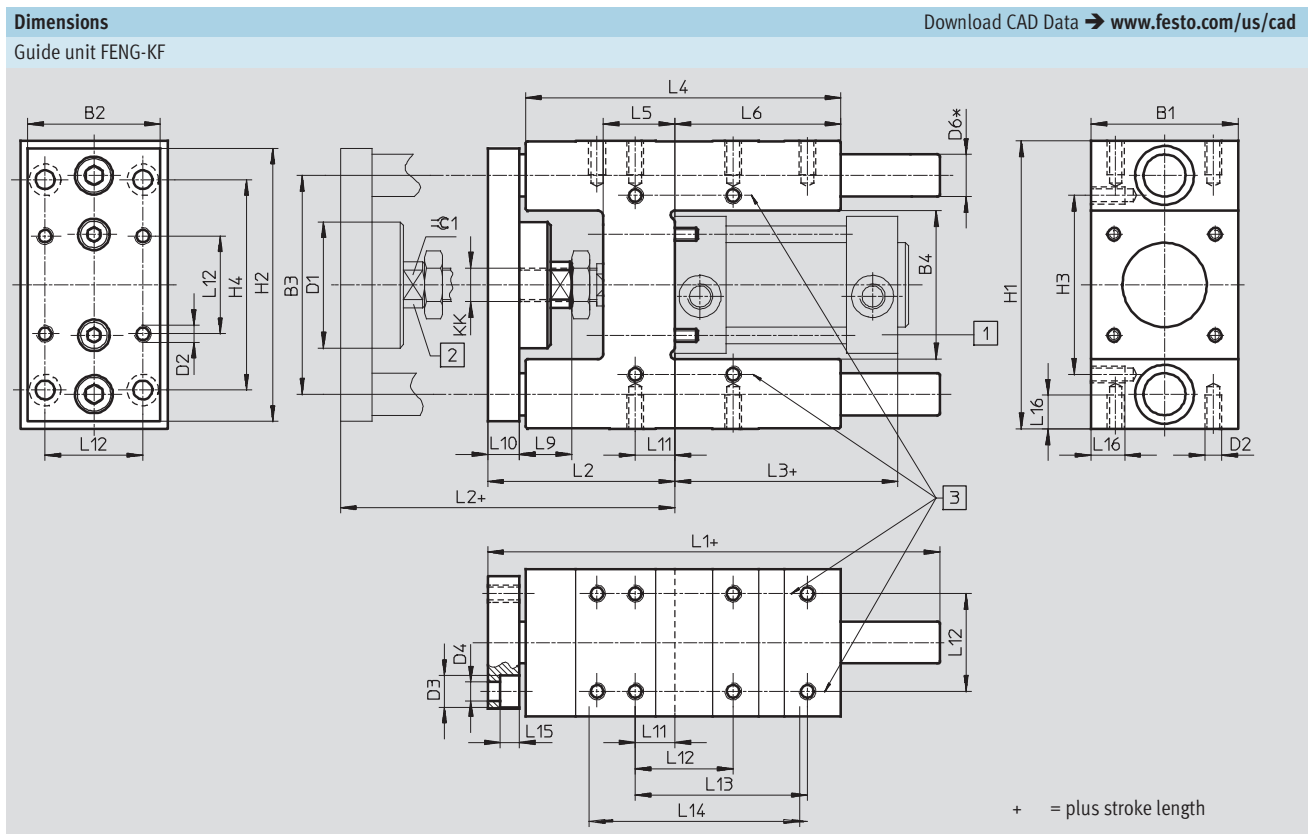

Technical data

For ∅	B1	B2	B3	B4	D1	D2	D3	D4	D6	H1
[mm]	-0.3		±0.2	±0.3	∅		∅	∅	∅ h6	
32	50	45	74	50.5	44	M6	11	6.6	12	97-0.4
40	58	54	87	58.5	44	M6	11	6.6	16	115-0.4
50	70	63	104	70.5	60	M8	15	9	20	137-0.5
63	85	80	119	85.5	60	M8	15	9	20	152-0.5

For Ø	H2	H3	H4	KK	L1	L2	L3	L4	L5	L6
[mm]		±0.2	±0.2							
32	90	61	78	M10x1.25	155	67 ₊₅	94	125	24	76
40	110	69	84	M12x1.25	170	75 ₊₅	105	140	28	81
50	130	85	100	M16x1	188	89 ₊₁₀	106	150	34	79
63	145	100	105	M16x1	220	89 ₊₁₀	121	182	34	111

For Ø	L9	L10	L11	L12	L13	L14	L15	L16	≈C1
[mm]				±0.2	±0.2	±0.2			
32	20	12	4.3	32.5	70.3	78	6.5	12	15
40	22	12	11	38	84	–	6.5	14	15
50	25	15	18.8	46.5	81.8	100	9	16	19
63	25	15	15.3	56.5	105	–	9	16	19

M Mandatory data →

Module No.	Function	Piston Ø	Stroke	Cushioning	Position sensing
535 411	DNCI	32	10 ... 2,000	P	A
535 412		40			
535 413		50			
535 414		63			
Order example					
535 411	DNCI	- 32	- 100	- P	- A

Ordering table

Piston Ø	32	40	50	63	Conditions	Code	Enter code
M Module No.	535 411	535 412	535 413	535 414			
Function	Standard cylinder with integrated displacement encoder, non-rotating piston rod					DNCI	DNCI
Piston Ø [mm]	32	40	50	63		-...	
Cushioning	Flexible cushioning rings/pads at both ends					-P	-P
↓ Position sensing	For proximity sensing					-A	-A

Transfer order code

-
 -
 -
 -
 -

O Options

Type of piston rod	Piston rod extended at front	Clamping unit	Guide	Measuring head
S2	...K8	KP	FENG	MS
-	-	-	-	-

Ordering table							
Piston Ø	32	40	50	63	Conditions	Code	Enter code
0	Type of piston rod	Through piston rod				-S2	
	Piston rod extended [mm]	1 ... 500			2	-...K8	
	Clamping unit	Clamping cartridge			3	-KP	
	Guide	Guide unit with ball bearing guide on the sensor head side			4	-FENG	
	Measuring head	No measuring head				-MS	

- 2 **K8** In combination with piston rod type S2, the piston rod is only extended at the front (the side facing the measuring head)

 3 **K9** Only with piston rod type S2

 4 **FENG** Maximum stroke length 500 mm

Transfer order code

- - - - - -

Accessories

Foot mounting HNC

Material:
galvanised steel
Free of copper, PTFE and silicone

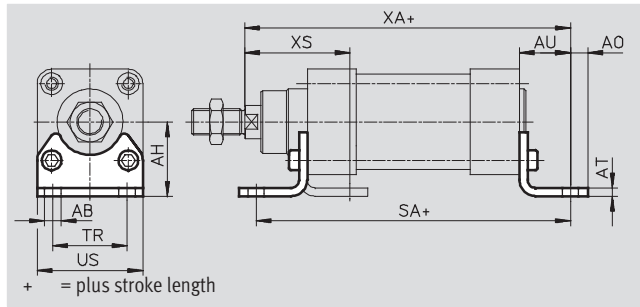

Dimensions and ordering data

For Ø [mm]	AB Ø	AH	AO	AT	AU	SA	
						Basic cylinder	KP
32	7	32	6.5	4	24	142	187
40	10	36	9	4	28	161	214
50	10	45	9.5	5	32	170	237
63	10	50	12.5	5	32	185	261

For Ø [mm]	TR	US	XA		XS	CRC ¹⁾	Weights [g]	Part No.	Type
			Basic cylinder	KP					
32	32	45	144	189	45	2	144	174 369	HNC-32
40	36	54	163	216	53	2	193	174 370	HNC-40
50	45	64	175	242	62	2	353	174 371	HNC-50
63	50	75	190	266	63	2	436	174 372	HNC-63

1) Corrosion resistance class 2 according to Festo standard 940 070
Components requiring moderate corrosion resistance. Externally visible parts with primarily decorative surface requirements which are in direct contact with a normal industrial environment or media such as coolants or lubricating agents

Accessories

Flange mounting FNC

Material:
FNC: galvanised steel
Free of copper, PTFE and silicone

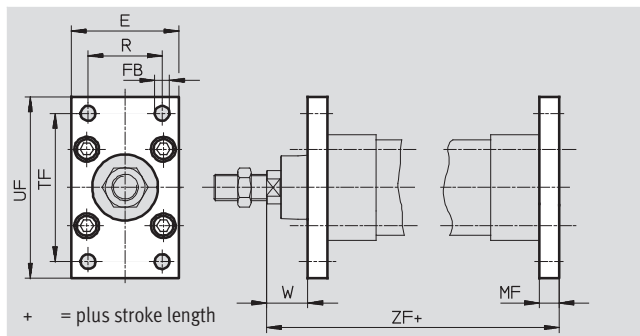

Dimensions and ordering data

For Ø [mm]	E	TC Ø H13	MF	R	TF	UF	W	ZF		CRC ¹⁾	Weights [g]	Part No.	Type
								Basic cylinder	KP				
32	45	7	10	32	64	80	16	130	175	2	240	174 376	FNC-32
40	54	9	10	36	72	90	20	145	198	2	280	174 377	FNC-40
50	65	9	12	45	90	110	25	155	222	2	520	174 378	FNC-50
63	75	9	12	50	100	120	25	170	246	2	690	174 379	FNC-63

1) Corrosion resistance class 2 according to Festo standard 940 070
Components requiring moderate corrosion resistance. Externally visible parts with primarily decorative surface requirements which are in direct contact with a normal industrial environment or media such as coolants or lubricating agents

Rod eye SGS

Scope of delivery:

1 rod eye, 1 hex nut to DIN 439

Material:

galvanised steel

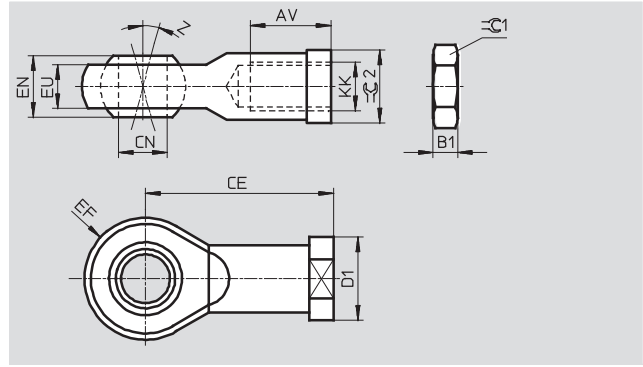

Dimensions and ordering data														
For \varnothing	AV	B1	CE	CN	D1	EF	EN	Z	$\approx C1$	$\approx C2$	CRC ¹⁾	Weights	Part No.	Type
[mm]				\varnothing H7	\varnothing	± 0.5		[°]				[g]		
M10x1.25	20 -2	5	43	10	19	14	14	13	17	17	2	70	9 261	SGS-M10x1,25
M12x1.25	22 -2	6	50	12	22	16	16	13	19	19	2	105	9 262	SGS-M12x1,25
M16x1.5	28 -2	8	64	16	27	21	21	15	24	22	2	210	9 263	SGS-M16x1,5

1) Corrosion resistance class 2 according to Festo standard 940 070

Components requiring moderate corrosion resistance. Externally visible parts with primarily decorative surface requirements which are in direct contact with a normal industrial environment or media such as coolants or lubricating agents

Accessories

Trunnion mounting kit ZNCM

The mounting kit can be attached at any position along the profile barrel of a cylinder.

Material:

tempered steel

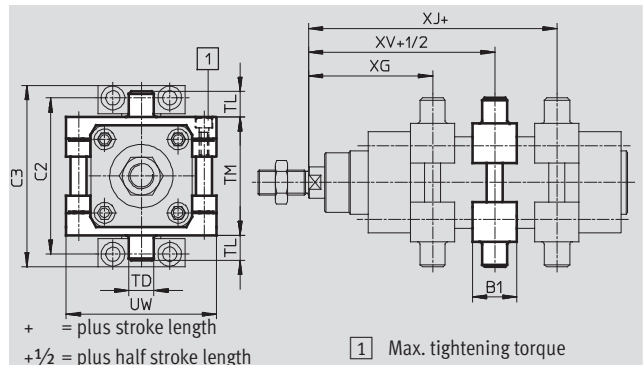

Dimensions and ordering data									
For \varnothing	B1	C2	C3	TD	TL	TM	UW	XG	
[mm]				\varnothing e9				Basic cylinder	KP
32	30	71	86	12	12	50	65	66.1	111.1
40	32	87	105	16	16	63	75	75.6	128.6
50	34	99	117	16	16	75	95	83.6	150.6
63	41	116	136	20	20	90	105	93.1	169.1

For \varnothing	XJ		XV		Max. tightening torque	CRC ¹⁾	Weights	Part No.	Type
	Basic cylinder	KP	Basic cylinder	KP					
[mm]					[Nm]		[g]		
32	79.9	124.9	73	118	4+1	2	224	163 525	ZNCM-32
40	89.4	142.4	82.5	135.5	8+1	2	396	163 526	ZNCM-40
50	96.4	163.4	90	157	8+2	2	616	163 527	ZNCM-50
63	101.9	177.9	97.5	173.5	18+2	2	931	163 528	ZNCM-63

1) Corrosion resistance class 2 according to Festo standard 940 070

Components requiring moderate corrosion resistance. Externally visible parts with primarily decorative surface requirements which are in direct contact with a normal industrial environment or media such as coolants or lubricating agents

Trunnion supports LNZZ

Material:

Trunnion support:

Anodised aluminium

Plain bearing: Plastic

Free of copper, PTFE and silicone

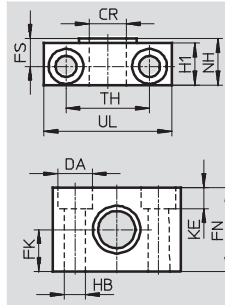

Dimensions and ordering data

For \varnothing [mm]	CR \varnothing D11	DA \varnothing H13	FK \varnothing ± 0.1	FN	FS	H1	HB \varnothing H13	KE	NH	TH ± 0.2	UL	CRC ¹⁾	Weights [g]	Part No.	Type
32	12	11	15	30	10.5	15	6.6	6.8	18	32	46	2	125	32 959	LNZZ-32
40, 50	16	15	18	36	12	18	9	9	21	36	55	2	400	32 960	LNZZ-40/50
63	20	18	20	40	13	20	11	11	23	42	65	2	480	32 961	LNZZ-63/80

1) Corrosion resistance class 2 according to Festo standard 940 070

Components requiring moderate corrosion resistance. Externally visible parts with primarily decorative surface requirements which are in direct contact with a normal industrial environment or media such as coolants or lubricating agents

Accessories

Ordering data

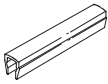
	For \varnothing	Remarks	Part No.	Type	PU ¹⁾
			Technical data → Internet: quick star		
	32	-	186 098	QS-G¹/₈-8	10
	40		186 099	QS-G¹/₄-8	10
	50		186 101	QS-G¹/₄-10	10
	63		186 100	QS-G³/₈-8	10
			186 102	QS-G³/₈-10	10
			Technical data → Internet: abp		
	32, 40, 50, 63		every 0.5 m		151 680
					2

1) Packaging unit quantity

Note

Recommended proximity sensor

→ Internet: dnc

Standard cylinders DNCM, external displacement encoder

Key features

Individual positioning components with standard cylinder DNCM ...



Proportional directional control valve
MPYE-...
→ Internet: mpye



Soft Stop → Internet: soft stop

End position controller
SPC11-POT-TLF



Positioning technology → Internet: spc

Axis interface
SPC-AIF-POT



Axis positioning controller
SPC200



Standard cylinders DNCM, external displacement encoder

Type code

		DNCM	-	32	-	400	-	P	-	POT2	-		-	FENG	-	
Type																
DNCM	Standard cylinder															
Piston Ø [mm]																
Stroke [mm]																
Cushioning																
P	Flexible cushioning rings/pads at both ends															
Encoder attachment position																
POT1	bottom															
POT2	at rear															
POT3	top															
Piston rod type																
S2	Through															
S20	Through, hollow															
Guide																
FENG	Guide unit with ball bearing guide															
Position sensing																
A	For proximity sensing															

Standard cylinders DNCM, external displacement encoder

Peripherals overview

FESTO

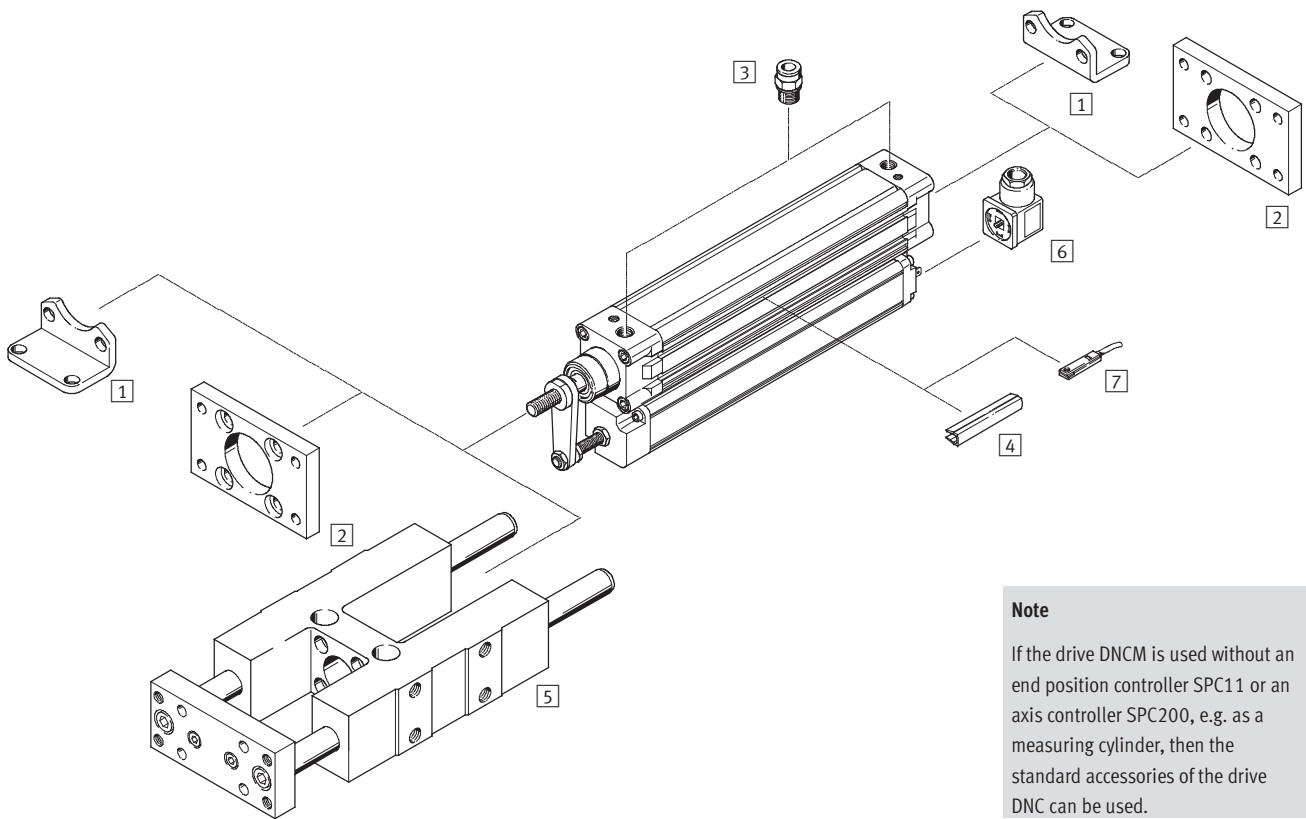

Note

If the drive DNCM is used without an end position controller SPC11 or an axis controller SPC200, e.g. as a measuring cylinder, then the standard accessories of the drive DNC can be used.

Standard cylinders DNCM, external displacement encoder

Peripherals overview

Accessories		
Type	Brief description	→ Page/Internet
1 Foot mounting HNC	to mount the drive on the bearing and end cap	33
2 Flange mounting FNC	to mount the drive on the bearing and end cap	33
3 Push-in fitting QS	for connecting compressed air tubing with standard O.D.	34
4 Slot cover ABP-5-S	to protect against the ingress of dirt	33
5 Guide unit ¹⁾ FENG-KF	to protect against torsion at high torque loads	feng
6 Plug socket MSSD-C-4P	to connect the displacement encoder, is part of the end position controller SPC11 and the axis controller SPC200	34
7 Proximity sensors SME-/SMT-8	for additional sensing of the piston position, can be ordered optionally, only in conjunction with the order code A in the drive's modular product section.	proximity sensor

1) FENG-KF must be attached to the piston rod such that backlash is excluded.

Standard cylinders DNCM, external displacement encoder

Technical data

Function

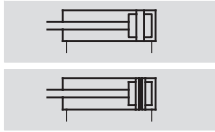

- N- Diameter
32 mm and 50 mm
- T- Stroke length
100 ... 500 mm



General technical data		
Piston Ø	32	50
Design	Piston Piston rod Profile barrel	
Mode of operation	Double-acting	
Operating medium ¹⁾	Compressed air, filtered and unlubricated, filter unit 5 µm	
Cushioning	Flexible cushioning rings/pads at both ends	
Position sensing	Displacement encoder, attached externally Proximity sensor ²⁾	
Measuring principle (displacement encoder)	Analogue with encoder, contacting and absolute measurement	
Type of mounting	Foot mounting	
Stroke ³⁾	[mm]	100, 160, 200, 250, 320, 400, 500
Torsion protection/Guide ⁴⁾	Guide rod with yoke, with ball bearing guide	
Stroke	[mm]	100, 160, 200, 250
Pneumatic connection	G1/8	G1/4
Electrical connection	4-pin plug, type A DIN 43 650	

- 1) The proportional directional control valve MPYE used requires the characteristic values.
- 2) Not included in the scope of delivery, can be ordered as an option.
- 3) Note stroke reduction in conjunction with SPC200.
- 4) FENG-KF guide must be ordered as an option and will be supplied attached, the max. stroke is reduced.

Forces [N] and impact energy [Nm]		
Piston Ø	32	50
Theoretical force at 6 bar advancing	483	1,178
Theoretical force at 6 bar retracting	415	990
Max. impact energy at end positions	0.1	0.2

Permissible impact velocity:

$$v_{perm.} = \sqrt{\frac{2 \times E_{perm.}}{m_{dead} + m_{load}}}$$

Maximum permissible load:

$$m_{load} = \frac{2 \times E_{perm.}}{v^2} - m_{dead}$$

- v_{perm.} Permissible impact velocity
- E_{perm.} Max. impact energy
- m_{dead} Moving load (drive)
- m_{load} Moving work load

Note
These specifications represent the maximum values which can be reached. Note the maximum permitted impact energy.

Standard cylinders DNCM, external displacement encoder

FESTO

Technical data

Positioning characteristics with axis controller SPC200			
Piston Ø		32	50
Repetition accuracy	horizontal	[mm]	±0.2
	vertical	[mm]	±0.2 (for stroke 0 ... 200 mm)
		[mm]	±0.4 (for stroke 200 ... 500 mm)
Mounting position		Any	
Minimum load, horizontal ¹⁾		[kg]	3
Maximum load, horizontal ¹⁾⁶⁾		[kg]	45
Minimum load, vertical ¹⁾		[kg]	3
Maximum load, vertical ¹⁾⁶⁾		[kg]	15
Min. speed of travel		[m/s]	0.05
Max. speed of travel		[m/s]	2.2
Typ. positioning time, long stroke ²⁾		[s]	0.45/0.75
Typ. positioning time, short stroke ³⁾		[s]	0.35/0.55
Minimum positioning stroke ⁴⁾		[mm]	3
Stroke reduction ⁵⁾		[mm]	≥ 10
Recommended proportional directional control valve			→ 34

- 1) Load = effective load + mass of all moving parts on the drive
- 2) At 6 bar, horizontal mounting position, DNCM-XX-500, 400 mm positioning travel at min./max. load
- 3) At 6 bar, horizontal mounting position, DNCM-XX-500, 100 mm positioning travel at min./max. load
- 4) In relation to the maximum stroke of the drive, but never more than 20 mm.
- 5) The stroke reserve is to be maintained on every side of the drive, the max. positionable stroke is therefore: Stroke – 2x stroke reserve
- 6) With external guide

Positioning characteristics with Soft Stop end position controller SPC11			
Piston Ø		32	50
Repetition accuracy of a mid-position ¹⁾		[mm]	±2
Mounting position		horizontal	
Minimum load, horizontal ²⁾		[kg]	3
Maximum load, horizontal ²⁾		[kg]	45
Travel time		→ Sizing software "Smart Soft Stop": → www.festo.com	
Recommended proportional directional control valve			→ 34

- 1) In the stroke range from 100 ... 500 mm
- 2) Load = effective load + mass of all moving parts on the drive

Operating and environmental conditions			
Piston Ø		32	50
Operating pressure ¹⁾		[bar]	4 ... 8
Ambient temperature ²⁾		[°C]	-10 ... +80
Vibration resistance		To DIN/IEC 68 Parts 2 -6, severity level 2	
Continuous shock resistance		To DIN/IEC 68 Parts 2 -27, severity level 2	
CE marking symbol (see conformity declaration)		As per EU EMC directive	
Protection class (displacement encoder)		IP54 to IEC 60 529	
Corrosion resistance class CRC ³⁾		1	

- 1) Only applies for applications with the Soft Stop end position controller SPC11 and axis controller SPC200.
- 2) Note operating range of proximity sensors
- 3) Corrosion resistance class 1 according to Festo standard 940 070
Components requiring low corrosion resistance. Transport and storage protection.

Weights [g] with displacement encoder								
Piston Ø		Stroke						
		100	160	200	250	320	400	500
32	Product weight	1,160	1,406	1,640	1,990	2,312	2,640	3,190
	Moving load	310	375	430	490	565	660	760
50	Product weight	2,270	2,684	3,030	3,520	4,038	4,590	5,420
	Moving load	850	1,010	1,125	1,265	1,455	1,675	1,935

Standard cylinders DNCM, external displacement encoder

Technical data

Electrical data, displacement encoder									
Stroke		100	160	200	250	320	400	500	
Power supply ¹⁾	[V DC]	10							
Max. current consumption	[mA]	4							
Wiper current	recommended	[μA]						< 1	
	maximum ²⁾	[mA]						10	
Connection resistance		[kΩ]	3	5					
	Connection resistance tolerance	[%]	±20						
Resolution	[mm]	≤ 0.01							
Independent linearity	maximum	[%]	0.09	0.08	0.07	0.06	0.05	0.05	0.05
Temperature coefficient	[ppm/°K]	≤ 5							
Interface	Analogue								

1) Stabilised power supply is recommended, max. 42 V DC permissible.

2) Only permissible in the short-term in the event of a fault.

Materials

Sectional view

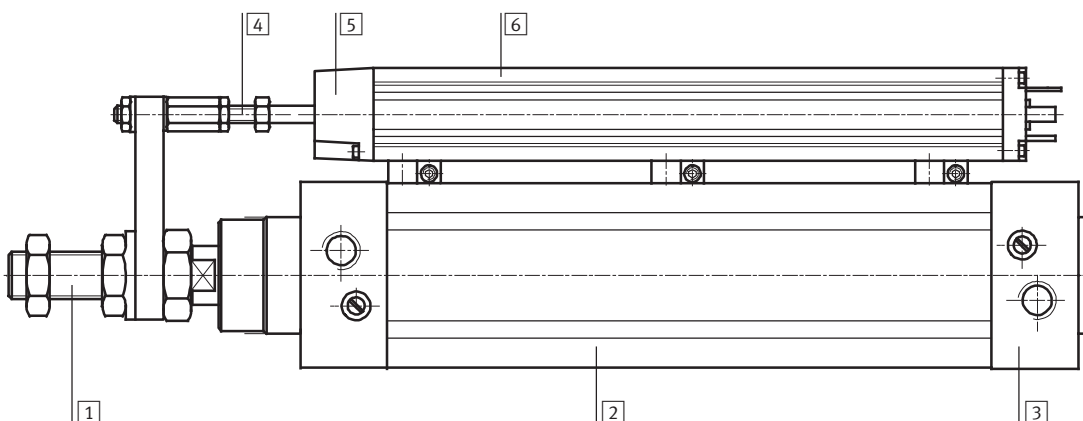

Drive			
1	Piston rod	High-alloy steel	
2	Cylinder barrel	Anodised aluminium	
3	Bearing/end caps	Die-cast aluminium	
-	Dynamic seals	Polyurethane TPE-U	
-	Static seals	Nitrile rubber	
-	Lubricant	Klüberplex BE31-102	
Displacement encoder			
4	Connecting rod	High-alloy steel	
5	Bearing cap	Reinforced polyester	
6	Profile	Anodised aluminium	
-	Resistor element	Conductive plastic	
-	Wiper	Contact	Precious metal
		Silencer	Elastomer
-	Cover seal	Nitrile rubber	
-	Rod seal	Tetrafluoroethylene	
-	Lubricant	ISOFLEX Topas MB52	

Standard cylinders DNCM, external displacement encoder

Technical data

FESTO

Torques and lateral forces

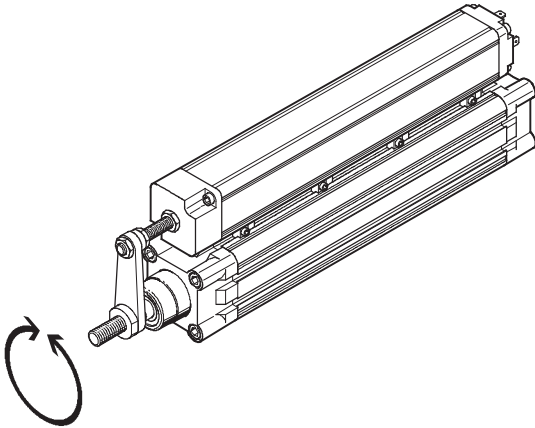

Note

Torques or lateral forces can result in inaccurate measurement results. We therefore recommend that an external guide be used with the drive DNCM.

This must be attached to the piston rod such that backlash is excluded.

Use of the DNCM with the FENG-KF is recommended. The drive is delivered with the guide attached.

The permissible static and dynamic characteristic load values with and without attached guide
→ Internet: dnc

Technical data for the S2 and S20 designs of the piston rod
→ Internet: dnc

Standard cylinders DNCM, external displacement encoder

Technical data

Dimensions

Download CAD Data → www.festo.com/us/cad

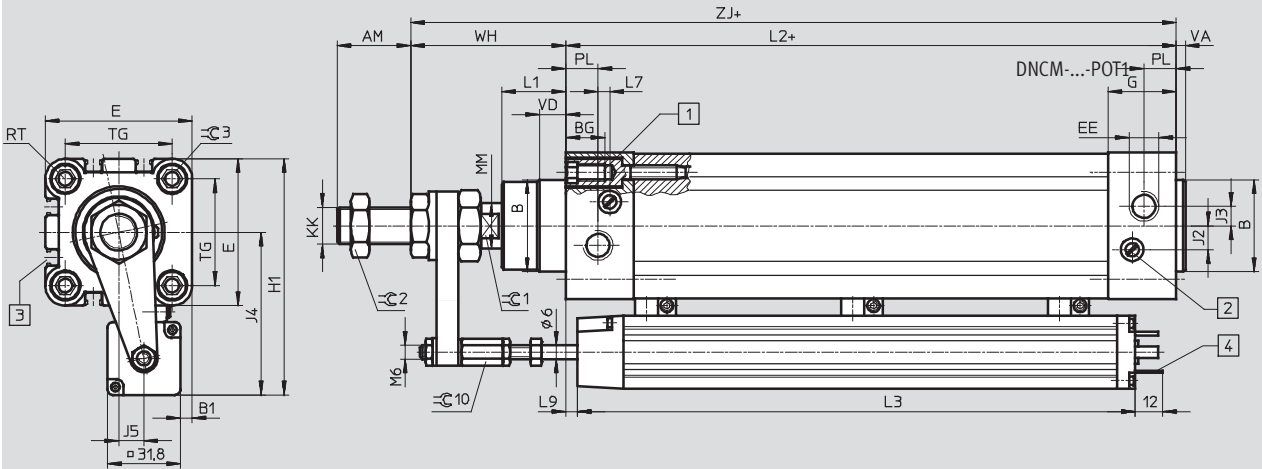

DNCM-...-POT2

DNCM-...-POT3

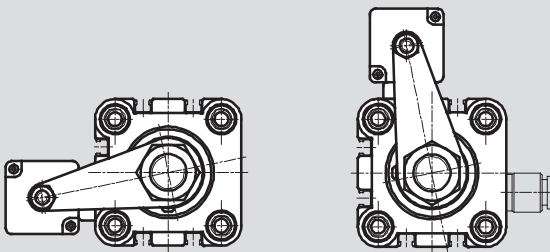

DNCM-...-S2/DNCM-...-S20

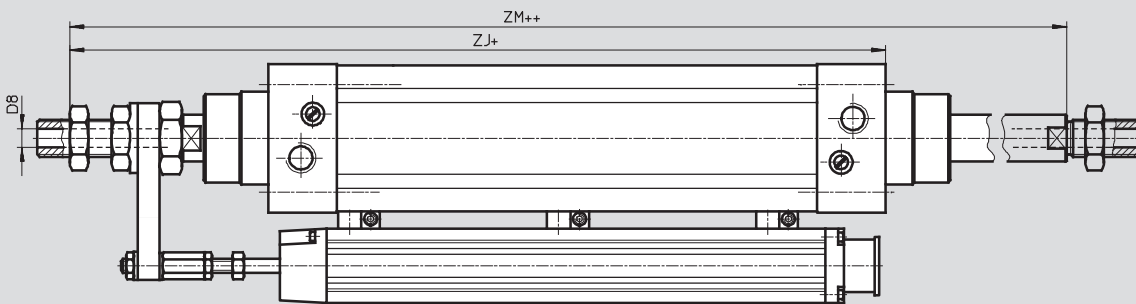

- | | | |
|---|---|---|
| <p>1 Socket head screw with female thread for mounting attachments</p> <p>2 Regulating screw for adjustable end-position cushioning</p> | <p>3 Sensor slot for proximity sensor SME/SMT-8</p> <p>4 Plug connector to DIN 43 650-A</p> | <p>+ = plus stroke length</p> <p>++ = plus 2x stroke length</p> |
|---|---|---|

Standard cylinders DNCM, external displacement encoder

FESTO

Technical data

∅ [mm]	AM	B ∅ d11	BG	B1 ±0.8	D8 ∅	E	EE	G	H1 ±1.5
32	22	30	16	0.24	4.5	45	G $\frac{1}{8}$	25.1	84.4
50	32	40	17	5.6	8	64	G $\frac{1}{4}$	29.6	103.4

∅ [mm]	J2	J3	J4 ±1	J5 ±1	KK	L1	L2
32	6	5.2	45.8	6.3	M10x1.25	18	94
50	10.4	8.5	55.3	10.6	M16x1.5	28	106

∅ [mm]	Stroke [mm]	L3	L7	L9	MM ∅ f8	PL	RT	TG	VA	VD
32	100	201	3.3	6.5 ±2	12	15.6	M6	32.5	4	10
	160	248		1 +2/-1						
	200	298		5 ±2						
	250	349		5.5 ±2						
	320	436		13 ±2						
	400	502		6 ±2						
	500	629		20 ±2						
50	100	201	5.1	6.5 ±2	20	14	M8	46.5	4	11.5
	160	248		1 +2/-1						
	200	298		5 ±2						
	250	349		5.5 ±2						
	320	436		13 ±2						
	400	502		6 ±2						
	500	629		0 ±2						

∅ [mm]	WH	ZJ	ZM	≈C1	≈C2	≈C3
32	44.4	138.4	166.4	10	16	6
50	67.4	173.4	213.4	17	24	8

Standard cylinders DNCM, external displacement encoder

Technical data



Dimensions

Download CAD Data → www.festo.com/us/cad

Guide unit FENG-KF

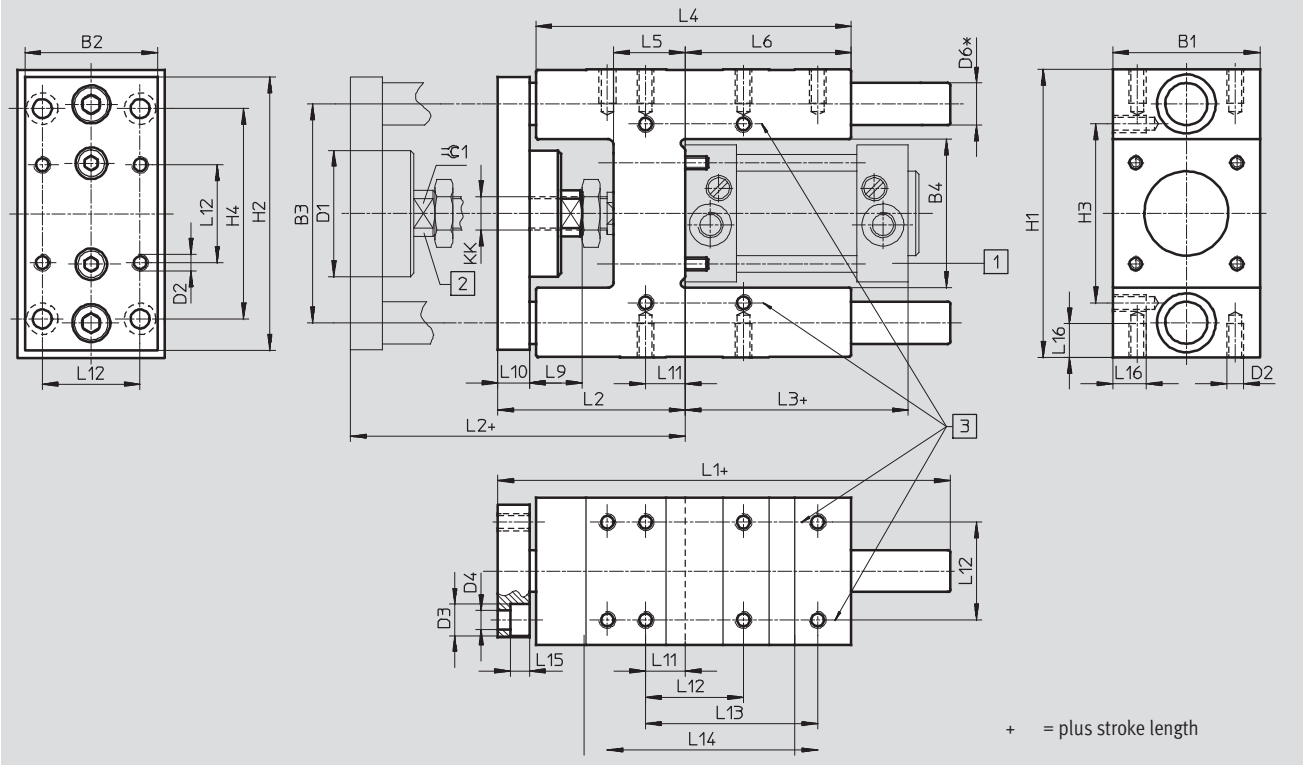

Standard cylinders DNCM, external displacement encoder

FESTO

Technical data

for \varnothing [mm]	B1 -0.3	B2	B3 ± 0.2	B4 ± 0.3	D1 \varnothing	D2	D3 \varnothing	D4 \varnothing
32	50	45	74	50.5	44	M6	11	6.6
50	70	63	104	70.5	60	M8	15	9

for \varnothing [mm]	D6 \varnothing h6	H1	H2	H3 ± 0.2	H4 ± 0.2	KK	L1	L2
32	12	97 _{-0.4}	90	61	78	M10x1.25	155	67 ₊₅
50	20	137 _{-0.5}	130	85	100	M16x1.5	188	89 ₊₁₀

for \varnothing [mm]	L3	L4	L5	L6	L9	L10	L11	L12 ± 0.2
32	94	125	24	76	20	12	4.3	32.5
50	106	150	34	79	25	15	18.8	46.5

for \varnothing [mm]	L13 ± 0.2	L14 ± 0.2	L15	L16	$\approx \varnothing 1$	Stroke [mm]	Weight per 10 mm stroke [g]	Weight [g]
32	70.3	78	6.5	12	15	10 ... 500	18	1 530
50	81.8	100	9	16	19	10 ... 500	50	4 030

Standard cylinders DNCM, external displacement encoder

Ordering data – Modular product system

Arrangement of the displacement encoder

DNCM-...-POT1 (encoder underneath)

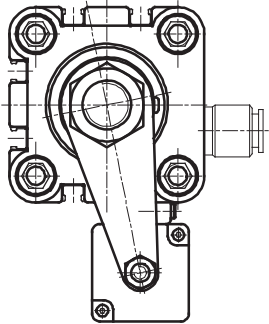

DNCM-...-POT2 (encoder at rear)

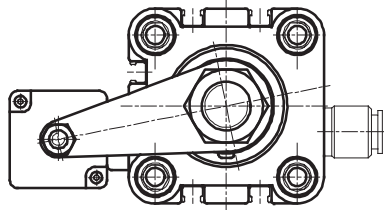

DNCM-...-POT3 (encoder on top)

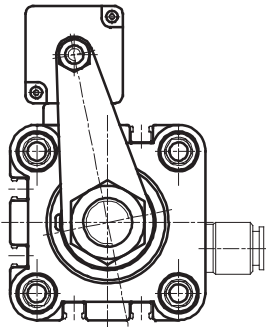

Standard cylinders DNCM, external displacement encoder



Ordering data – Modular product system

M Mandatory data						O Options		
Module No.	Basic function	Size	Stroke	Cushioning	Encoder attachment position	Piston rod type	Guide	Position sensing
528 940 528 941	DNCM	32 50	100 160 200 250 320 400 500	P	POT1 POT2 POT3	S2 S20	FENG	A
Ordering example								
528 941	DNCM	- 50	- 500	- P	- POT3	- S20	-	- A

Ordering table						
Size	32	50	Conditions	Code	Enter code	
M Module No.	528 940	528 941				
Basic function	Standard cylinder with displacement encoder			DNCM		DNCM
Size [mm]	32	50		-...		
Stroke [mm]	100			-100		
	160			-160		
	200			-200		
	250			-250		
	320			-320	1	
	400			-400	1	
	500			-500	1	
Cushioning	Flexible cushioning rings/plates at both ends			-P		-P
Encoder attachment position	Encoder underneath			-POT1		
	Encoder at rear			-POT2		
	Encoder on top			-POT3		
O Piston rod type	Through piston rod			-S2	1	
	Through, hollow piston rod			-S20	1	
Guide	Guide unit with ball bearing guide KF			-FENG	2	
Position sensing	For proximity sensing			-A		

1 320, 400, 500, S2, S20 Not with guide FENG.

2 FENG Only with POT2 encoder. FENG is mounted without backlash.

Transfer order code

	DNCM	-		-		-	P	-		-		-		-	
--	------	---	--	---	--	---	---	---	--	---	--	---	--	---	--

Standard cylinders DNCM, external displacement encoder

Accessories

Foot mounting HNC

Material:
Galvanised steel
Free of copper, PTFE and silicone

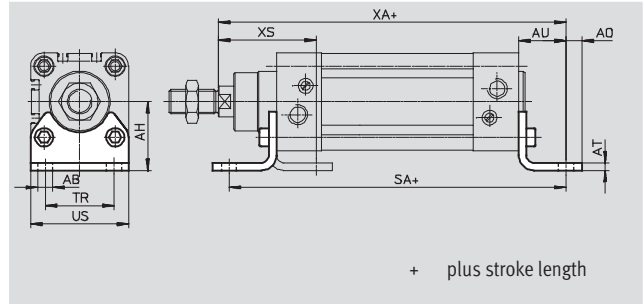

Dimensions and ordering data													
for \varnothing	AB	AH	AO	AT	AU	SA	TR	US	XA	XS	Weight	Part No.	Type
[mm]	\varnothing										[g]		
32	7	32	6.5	4	24	142	32	45	144	45	144	174 369	HNC-32
50	10	45	9.5	5	31	170	45	64	175	62	353	174 371	HNC-50

Flange mounting FNC

Material:
Galvanised steel
Free of copper, PTFE and silicone

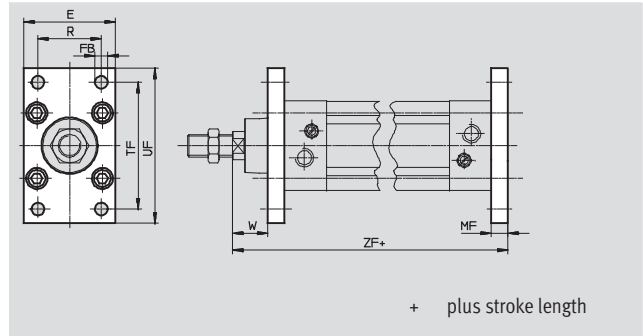

Dimensions and ordering data											
for \varnothing	E	FB	MF	R	TF	UF	W	ZF	Weight	Part No.	Type
[mm]		\varnothing H13							[g]		
32	45	7	10	32	64	80	16	130	240	174 376	FNC-32
50	65	9	12	45	90	110	25	155	520	174 378	FNC-50

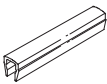
Ordering data – Slot cover			Technical data → Internet: abp		
	for \varnothing	Remarks	Part No.	Type	PU ¹⁾
	[mm]				
Slot cover ABP-S					
	32, 50	0.5 m each	151 680	ABP-5-S	2

1) Packaging unit quantity

Standard cylinders DNCM, external displacement encoder

Accessories

Ordering data – Push-in/threaded fittings			Technical data → Internet: quick star		
	for Ø [mm]	Remarks	Part No.	Type	PU ¹⁾
	32	for connecting compressed air tubing with standard O.D.	186 098	QS-G$\frac{1}{8}$-8	10
	50		186 099	QS-G$\frac{1}{4}$-8	

1) Packaging unit quantity

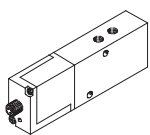
Ordering data – Proportional directional control valves			Technical data → Internet: mpYE		
	for Ø [mm]	Stroke [mm]	Part No.	Type	
	for applications with axis controller SPC200				
	32	100/160/200/250/320	151 692	MPYE-5-$\frac{1}{8}$-LF-010-B	
		400/500	151 693	MPYE-5-$\frac{1}{8}$-HF-010-B	
	50	100/160/200/250/320/400/500	151 693	MPYE-5-$\frac{1}{8}$-HF-010-B	
		for applications with Soft Stop end position controller SPC11			
	32	100/160/200/250/320/400	151 692	MPYE-5-$\frac{1}{8}$-LF-010-B	
		500	151 693	MPYE-5-$\frac{1}{8}$-HF-010-B	
	50	100/160/200/250	151 692	MPYE-5-$\frac{1}{8}$-LF-010-B	
320/400		151 693	MPYE-5-$\frac{1}{8}$-HF-010-B		
500		151 694	MPYE-5-$\frac{1}{4}$-010-B		

Ordering data – Plug socket

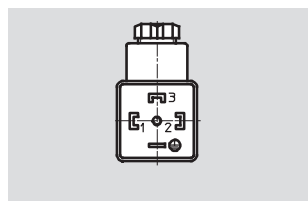

PIN	Pin allocations	Designation	Part No.	Type
1	Power supply	Plug socket	171 157	MSSD-C-4P
2	Signal			
3	0 V			
PE	PE (yellow), screen			

Note
Recommended proximity sensor
→ Internet: dnc

Linear drives DGCI, with displacement encoder

Key features

Individual components for positioning with axis controller CPX-CMAX or end-position controller CPX-CMPX

Axis controller/
end-position controller
CPX-CMAX/
CPX-CMPX



Proportional
directional control valve
VPWP



Linear drive
DGCI



Individual components for positioning with axis controller SPC200 or end-position controller SPC11

Axis controller
SPC200



Proportional
directional control valve
MPYE



Axis interface
SPC-AIF-POT-LWG



Linear drive
DGCI



End-position controller
SPC11



Proportional
directional control valve
MPYE



Linear drive
DGCI



New
Lubrication adapter

Linear drives DGCI, with displacement encoder

Key features

FESTO

At a glance

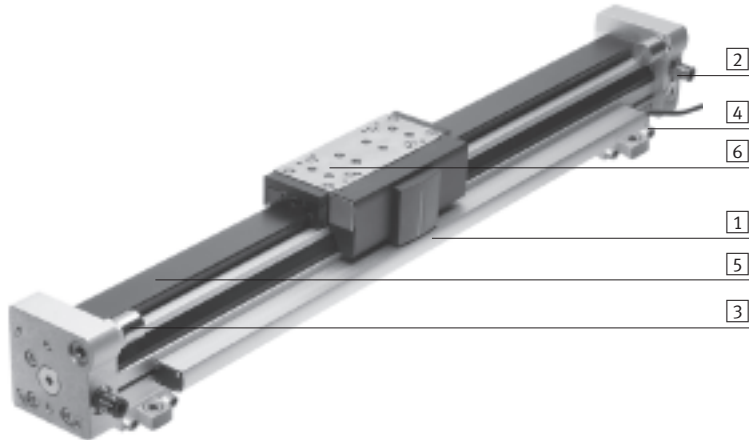

- | | | | |
|--|--|--|---|
| <p>1 Displacement encoder →43</p> <ul style="list-style-type: none"> • High degree of protection IP67 • Non-contacting • Measures absolute values | <p>2 Supply ports →56</p> <ul style="list-style-type: none"> • Optionally on two sides (on the end face or at the front) • Optionally with different coloured push-in fittings for simple and error-free tubing connections | <p>3 End stops →47</p> <ul style="list-style-type: none"> • Metal fixed stop • Shock absorber, precisely adjustable | <p>4 Profile mounting →44</p> <ul style="list-style-type: none"> • Profile mountings remain on the base plate after the drive is dismantled. This saves time during assembly and removal |
| <p>5 Recirculating ball bearing guide →41</p> <ul style="list-style-type: none"> • Piston Ø 18 ... 63 mm • Stroke lengths 100 ... 2,000 mm • Guide backlash = 0 mm • For medium and large loads • Precision mounting interface with stainless steel slide • Operating behaviour under torque load = very good | <p>6 Recirculating ball bearing guide with protected guide →41</p> <ul style="list-style-type: none"> • Piston Ø 18 ... 40 mm • Stroke lengths 100 ... 2,000 mm • Guide backlash = 0 mm • The protected guide cleans the recirculating ball bearing guide by means of an additional wiper seal and lubrication unit | <p>– Passive guide axis DGC-FA → dgc-fa</p> <ul style="list-style-type: none"> • Without drive • Piston Ø 8 ... 63 mm • Stroke lengths 1 ... 5,000 mm • Guide backlash = 0 mm • Precision guide, suitable for DGCI. Can be used as a machine component or as a twin guide with DGCI | <p>– Passive guide axis with protected guide DGC-FA-GP → dgc-fa</p> <ul style="list-style-type: none"> • Without drive • Piston Ø 18 ... 63 mm • Stroke lengths 1 ... 5,000 mm • Guide backlash = 0 mm • The protected guide cleans the guide rail and protects the recirculating ball bearing guide by means of an additional wiper seal and lubrication unit |

Central lubrication

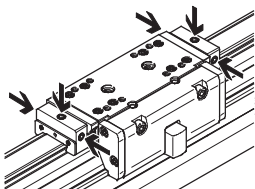

The lubrication adapter enables the guide of the linear drive DGCI to be permanently lubricated in applications in humid or wet ambient conditions using semi or fully automatic relubrication devices. The adapters are suitable for oils and greases.

- For piston Ø 25, 32, 40, 63 mm
- Connections:
 - On both sides of the slide
 - In three places (front, top, rear) on each side

Technical data → 46

Order code C in the modular product system → 58

Linear drives DGCI, with displacement encoder

Peripherals overview

Note

Drive must not be operated without end stops or shock absorbers.

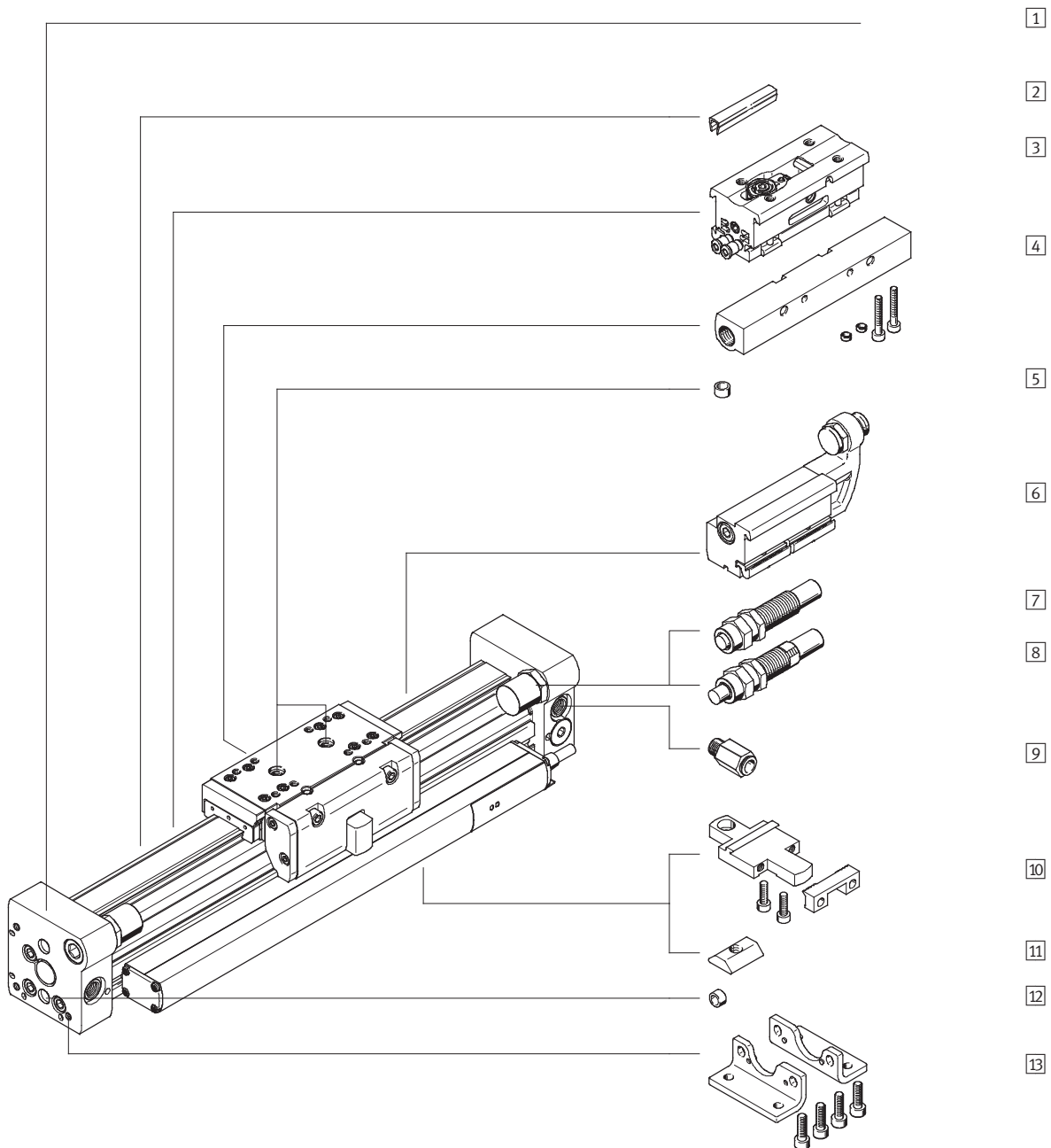

Linear drives DGCI, with displacement encoder

Peripherals overview

Variants and accessories			
Type	For piston Ø	Brief description	→ Page/Internet
1 Linear drive DGCI-KF	18 ... 63	Linear drive without accessories, with recirculating ball bearing guide.	41
2 Slot cover L	18 ... 63	For protecting against ingress of dirt and securing proximity sensor cables.	65
3 Intermediate position module DADM-DGC	25, 32	Facilitates intermediate positions with metal fixed stop. The module can be attached.	63
4 Shock absorber retainer DADP-DGC	18 ... 63	For variable end-position adjustment in combination with the stop KYC.	61
5 Centring pin/sleeve ¹⁾ ZBS/ZBH	18 ... 63	For centring loads and attachments on the slide.	65
6 Stop KYC	18 ... 63	For variable end-position adjustment in combination with the shock absorber retainer DADP-DGC.	61
7 Shock absorber YSR	18 ... 63	Self-adjusting hydraulic shock absorber with spring return and linear cushioning characteristics.	57
8 Shock absorber YSRW	18 ... 63	Self-adjusting hydraulic shock absorber with spring return and progressive cushioning characteristics.	57
9 Push-in fitting QS	18 ... 63	For connecting compressed air tubing with standard O.D.	56
10 Profile mounting M	18 ... 63	Simple and precise mounting option via dovetail connection.	60
11 Slot nut B	25 ... 63	For mounting attachments.	65
12 Centring pin/sleeve ¹⁾ ZBS/ZBH	18 ... 63	For centring the drive without foot mountings (user-specific).	65
13 Foot mounting F	18 ... 63	For mounting on the end cap.	59
- Proportional directional control valve MPYE	18 ... 63	Regulates the compressed air and therefore the position of the slide.	67

1) Included in the scope of delivery of the drive

Note

Allocation table of drives and associated proportional directional control valves → 67

Linear drives DGCI, with displacement encoder

FESTO

Type codes

		DGCI	-	25	-	1000	-	KF	-		-		-		-		-		
Type																			
DGCI	Linear drive with displacement encoder																		
Piston Ø [mm]																			
Stroke [mm]																			
Guide																			
KF	Recirculating ball bearing guide																		
Alternative supply port																			
	Push-in fitting at both ends, front																		
QD	Push-in fitting at both ends, end face																		
QR	Push-in fitting at one end, end face, right side																		
Q	Threaded connection, end face open, front sealed																		
Slide																			
GP	Protected recirculating ball bearing guide																		
Lubrication function																			
	Standard																		
C	Lubrication adapter																		
Additional slide																			
KL	Additional slide on left																		
KR	Additional slide on right																		
Cushioning																			
	Adjustable mechanical stop without cushioning																		
YSR	Shock absorber, self-adjusting																		
YSRW	Shock absorber, self-adjusting, progressive																		

Linear drives DGCI, with displacement encoder

Type codes



		ZUB	F		2B	
Accessories						
ZUB	Accessories enclosed separately					
Type of mounting						
F	Foot mounting					
M	Profile mounting					
Slot cover						
...L	For sensor slot					
Slot nut						
...B	For mounting slot					
Operating instructions						
0	Express waiver – no operating instructions to be included					

Linear drives DGCI, with displacement encoder

Technical data

Function

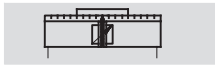

www.festo.com/en/
Spare_parts_service



- N- Diameter
18 ... 63 mm
- T- Stroke length
100 ... 2,000 mm

General technical data					
Piston Ø	18	25	32	40	63
Design	Rodless linear drive with displacement encoder				
Mode of operation	Double-acting				
Moment compensator principle	Slotted cylinder, mechanically coupled				
Guide	External recirculating ball bearing guide				
Mounting position	Any				
Type of mounting	Profile mounting				
	Foot mounting				
	Direct mounting				
Pneumatic connection ¹⁾	M5	G1/8		G1/4	G3/8
Cushioning → 45	<ul style="list-style-type: none"> • Via metal fixed stop • Optionally via shock absorber, self-adjusting at both ends 				
Position sensing	Via displacement encoder				
Measuring principle (displacement encoder)	Digital, magnetostrictive, non-contacting and absolute measurement				
Stroke ²⁾	[mm] 100; 160; 225; 300; 360; 450; 500; 600; 750; 850; 1,000; 1,250; 1,750; 2,000				
Protected version	Optional				-
Max. speed ³⁾	[m/s] 5				
Stroke tolerance	[mm] 0 ... 2.5				

- 1) Recommended push-in fittings → 65
With pre-assembled push-in fittings, the tubing diameters apply → 54
- 2) Note stroke reduction in combination with SPC200
- 3) Only applies to positioning using axis controller SPC200 and end-position controller SPC11. Otherwise a maximum speed of 3 m/s is permitted

Operating and environmental conditions					
Piston Ø	18	25	32	40	63
Operating pressure	[bar] 2 ... 8			1.5 ... 8	
Operating medium	Filtered and unlubricated compressed air, grade of filtration 5 µm				
Ambient temperature	[°C] -10 ... +60				
Vibration resistance to DIN/IEC 68, Part 2-6	At 10 ... 58 Hz: 0.15 mm				
	At 58 ... 150 Hz: 2G				
Continuous shock resistance to DIN/IEC 68, Part 2-27	Half sine 15g, 11 ms				
CE mark (see declaration of conformity)	To EU EMC Directive				
Certification	C-Tick				
Protection class (displacement encoder)	IP67				
Corrosion resistance class CRC ¹⁾	1				

- 1) Corrosion resistance class 1 according to Festo standard 940 070
Components subject to low corrosion stress. Transport and storage protection. Parts that do not have primarily decorative surface requirements, e.g. in internal areas that are not visible or behind covers.

Linear drives DGCI, with displacement encoder

Technical data

Forces [N] and impact energy [Nm]						
Piston Ø		18	25	32	40	63
Theoretical force at 6 bar		153	295	483	754	1,870
Impact energy in the end positions	With fixed stop	0.4	0.5	0.7	0.7	0.7
	With shock absorber YSR/YSRW	→ 45				

Positioning characteristics with axis controller SPC200						
Piston Ø		18	25	32	40	63
Repetition accuracy	[mm]	→ 43				
Mounting position		Any				
Minimum load, horizontal ¹⁾	[kg]	1	2	3	5	12
Maximum load, horizontal ¹⁾	[kg]	15	30	50	75	180
Minimum load, vertical ¹⁾	[kg]	1	2	3	5	12
Maximum load, vertical ¹⁾	[kg]	5	10	15	25	60
Minimum travel speed	[m/s]	0.05				
Maximum travel speed	[m/s]	5				
Typ. positioning time, long stroke ²⁾	[s]	0.75/1.15	0.65/1.00	0.65/1.05	0.70/1.05	1.05/1.20
Typ. positioning time, short stroke ³⁾	[s]	0.38/0.65	0.38/0.60	0.38/0.60	0.38/0.60	0.65/0.65
Minimum positioning stroke ⁴⁾	[%]	3				
Stroke reduction ⁵⁾	[mm]	20	25	25	35	35
Recommended proportional directional control valve		→ 67				

- 1) Load = effective load + mass of all moving parts on the drive
- 2) At 6 bar, horizontal mounting position, DGCI-XX-1000, 800 mm positioning travel at min./max. load
- 3) At 6 bar, horizontal mounting position, DGCI-XX-1000, 100 mm positioning travel at min./max. load
- 4) Referred to the maximum stroke of the drive, but never more than 20 mm
- 5) The stroke reduction is to be maintained on every side of the drive, the max. positionable stroke is therefore: stroke – 2x stroke reduction

Positioning characteristics with end-position controller SPC11						
Piston Ø		18	25	32	40	63
Intermediate-position repetition accuracy	[mm]	±2				
Mounting position		Any				
Minimum load, horizontal ¹⁾	[kg]	1	2	3	5	12
Maximum load, horizontal ¹⁾	[kg]	15	30	50	75	180
Minimum load, vertical ¹⁾	[kg]	1	2	3	5	12
Maximum load, vertical ¹⁾	[kg]	5	10	15	25	60
Travel time	[s]	→ SoftStop sizing software: → www.festo.com				
Recommended proportional directional control valve		→ 67				

- 1) Load = effective load + mass of all moving parts on the drive

Weight [g]						
Piston Ø		18	25	32	40	63
Basic weight with 0 mm stroke		1,200	2,400	3,100	7,300	22,500
Additional weight per 10 mm stroke		38	56	81	124	243
Moving load		360	770	1,170	2,360	8,200
Moving load on additional slide		300	650	950	2,000	5,600

Linear drives DGCI, with displacement encoder

Technical data

Materials

Sectional view

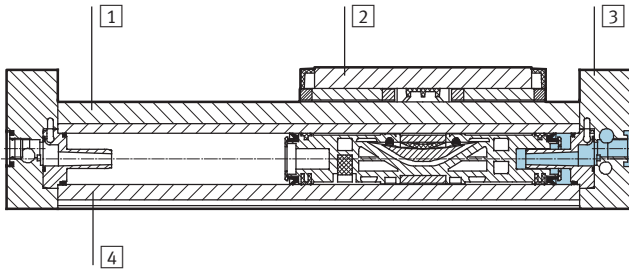

Linear drives		
1	Guide rail	High-alloy steel
2	Slide	High-alloy steel
3	End cap	Anodised aluminium
4	Cylinder profile, housing	Anodised aluminium
-	Seals, sealing band	Polyurethane
-	Guide band, dirt wiper, reversing roller	Polyacetal
-	Cover	Polyacetal, polyamide, powder-coated aluminium
-	Displacement encoder	Anodised aluminium, glass-fibre reinforced polyphthalamide
-	Cable	Polyurethane
-	Note on materials	Free of copper, PTFE and silicone

Electrical data for displacement encoder		
Linearity	[%]	±0.02 FS (min. ±50µm)
Resolution	[mm]	≤0.01
Interface		CAN to ISO/DIS 11898
Power supply	[V DC]	24 (±25%)
Current consumption	[mA]	Typically 100
Max. temperature coefficient	[ppm/°K]	15
Electrical connection		Cable with 5-pin plug, round type M9
Cable length	[m]	1.5
Cable quality		Suitable for use with energy chains

Pin allocation of plug for displacement encoder

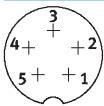

Pin	Function
1	24 V
2	-
3	0 V

Pin	Function
4	CAN_H
5	CAN_L
-	Screened

Repetition accuracy x as a function of stroke l

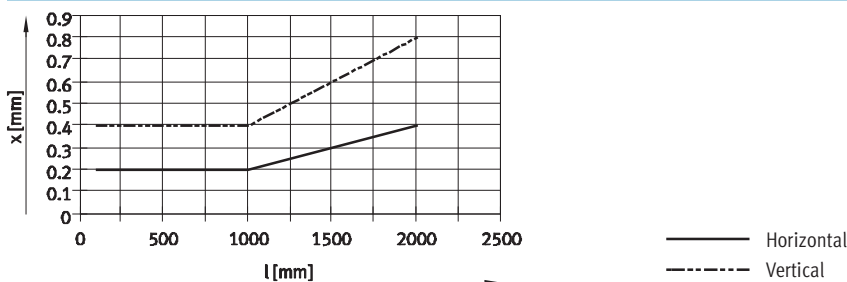

Linear drives DGCI, with displacement encoder

Technical data

Characteristic load values for linear drive with recirculating ball bearing guide and guide

The indicated forces and torques refer to the slide surface and the centre of the slide.

These values must not be exceeded during dynamic operation. Special attention must be paid to the cushioning phase.

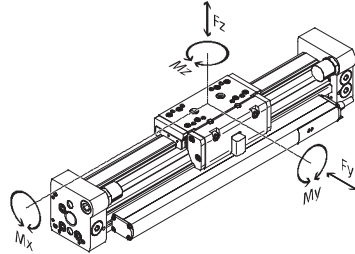

GP – Protected guide

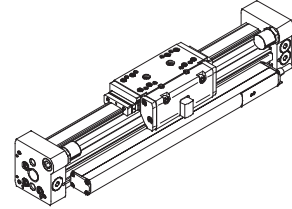

If the drive is simultaneously subjected to several of the forces and torques listed below, the following equation must be satisfied in addition to the indicated maximum loads:

$$\frac{F_y}{F_{y_{max}}} + \frac{F_z}{F_{z_{max}}} + \frac{M_x}{M_{x_{max}}} + \frac{M_y}{M_{y_{max}}} + \frac{M_z}{M_{z_{max}}} \leq 1$$

Note

To avoid distortion in the slide, the bearing surfaces of the attachments must maintain a flatness of 0.01 mm.

Permissible forces and torques

Piston Ø		18	25	32	40	63
F _y _{max.}	[N]	1,850	3,050	3,310	6,890	15,200
F _z _{max.}	[N]	1,850	3,050	3,310	6,890	15,200
M _x _{max.}	[Nm]	16	36	54	144	529
M _y _{max.}	[Nm]	51	97	150	380	1,157
M _z _{max.}	[Nm]	51	97	150	380	1,157

Number of profile mountings MUC as a function of overall length

Excessive distances between the profile mountings can reduce the positioning accuracy. The following table shows the required minimum number of profile and foot mountings.

Stroke [mm]	Number of mounting attachments		
	Order code M		Order code F
	Profile mounting	Foot mounting	+ profile mounting
100 ... 400			
401 ... 600	2	2	0
601 ... 1,200	2	2	1
1,201 ... 1,400	3	2	1
1,401 ... 2,000	3	2	2
1,401 ... 2,000	4	2	2

Linear drives DGCI, with displacement encoder

Technical data

Maximum permissible piston speed with shock absorber v as a function of effective load m

Piston \varnothing 18 ... 63 with YSR cushioning

Piston \varnothing 18 ... 63 with YSRW cushioning

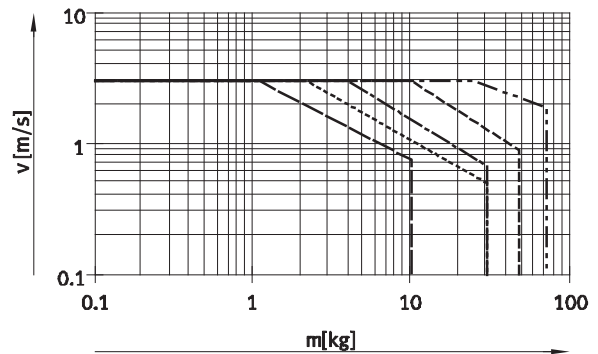
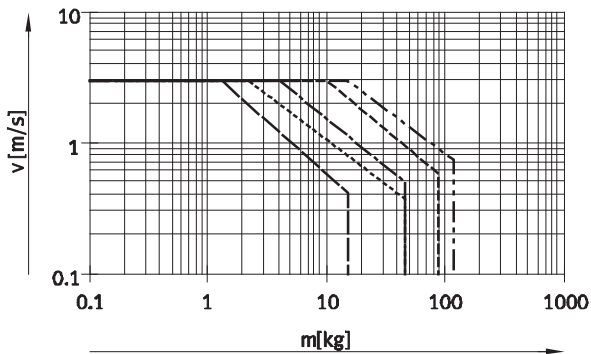

- \varnothing 18
- - - \varnothing 25
- · - \varnothing 32
- · - · - \varnothing 40
- · - · - · - \varnothing 63

Note

This data represents the maximum values that can be achieved.

In practice, values fluctuate relative to the size of the effective load.

Operating range of cushioning

The end-position cushioning must be adjusted to ensure jerk-free operation. If the operating conditions are outside the permissible range, the

load to be moved must be cushioned using suitable equipment (shock absorbers, stops, etc.), preferably at the centre of gravity of the load.

The data applies to a horizontal mounting position.

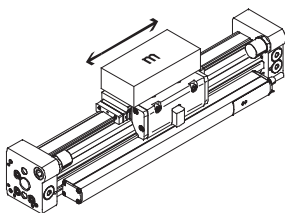

Piston \varnothing	18	25	32	40	63
Distance r_{max} [mm]	35	50	50	50	50

Linear drives DGCI, with displacement encoder

Technical data



Central lubrication

The lubrication adapter enables the guide of the linear drive DGCI to be permanently lubricated in applications in humid or wet ambient conditions using semi or fully automatic relubrication devices.

- For piston \varnothing 25, 32, 40, 63
- The modules are suitable for oils and greases
- The dimensions of the linear drive DGCI are the same with and without central lubrication modules
- Both lubrication adapters must be connected
- There are three connection options on each side
- Can be used in combination with:
 - Standard slide GK
 - Additional slide KL, KR
- Cannot be used in combination with:
 - Protected recirculating ball bearing guide GP

Slide dimensions

→ 53

Order code C in the modular product system → 58

Connection options

Only the connection at the rear or on the top can be used in combination with shock absorbers in the end caps.

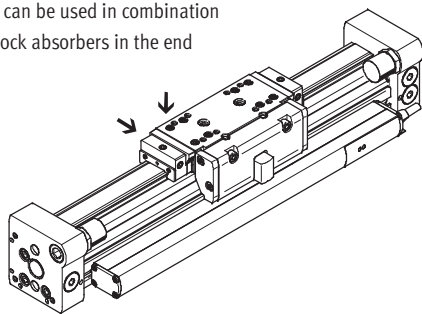

Only the connection on the front or top can be used in combination with shock absorber retainer DADP.

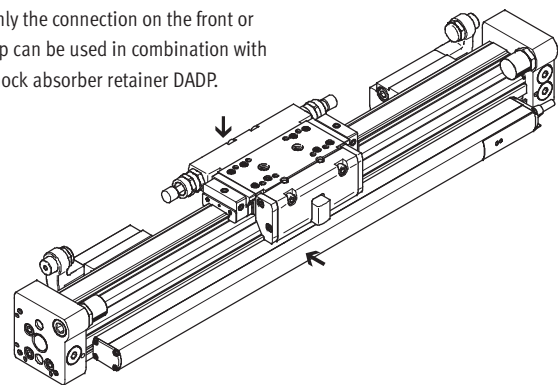

Connection option for customer design

The drawing opposite shows the connection option on the top lubrication interface using a customer design.

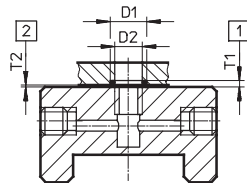

D1 $8^{+0.2}$ mm

D2 6 mm

T1 $0.6_{-0.05}$ mm

T2 $0.1^{+0.2}$ mm

O-ring \varnothing 6x1 mm (DIN 3771)

1 Slot depth for O-ring

2 Required air gap

Additional dimensions → 53

Structure of a central lubrication system

A central lubrication system requires various additional components. The illustration shows different options (using a hand pump, pneumatic container pump or electric container pump) required as a minimum for designing a central lubrication system. Festo does not sell these additional components, however they can be obtained from the following companies:

- Lincoln
- Bielomatik
- SKF (Vogel)

Festo recommends these companies because they can supply all the necessary components.

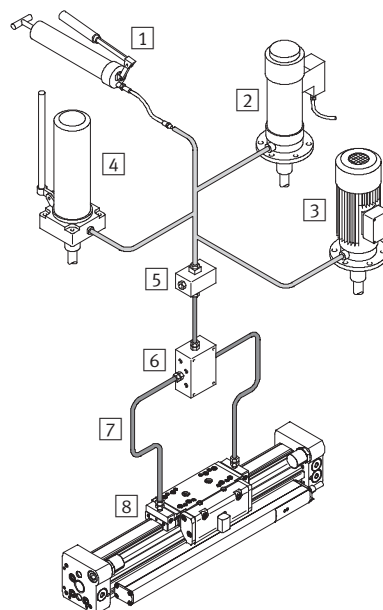

1 Hand pump

2 Pneumatic container pump

3 Electric container pump

4 Manually operated container pump

5 Nipple block

6 Distributor block

7 Tubing or piping

8 Fittings

Linear drives DGCI, with displacement encoder

Technical data

∅ [mm]	B1	B2	B3	B4 ±0.1	B5 ±0.05	B6	B7	B8 ±0.1	B9	B10	B11	B12
18	44.5	49.9	19.5	8.8	21	31	-	3.8	1	2.4	5.5	15.5
25	59.8	66	30	12.65	30	42	1	6.65	1	3.5	9.3	21
32	73	79	38.5	5.7	63.1	57.5	-	8.5	1.5	14	14.9	18
40	91	98.5	45	17.2	55	65	-	12.2	2	8	16.5	24.8
63	142	149	68	-	-	97	-	19.5	5	15.5	21	30

∅ [mm]	B13	B14 ±0.05	B15	B16	D1 ∅	D2	D3 ∅ H7	D4	EE	H1	H2	H3
18	39	19.5	68.3	0.8	2±0.05	M4	5	M12x1	M5	56.3	23.1	55
25	53	29	82.4	-	3±0.05	M5	9	M16x1	G ¹ / ₈	68	29	67
32	65	38.5	97.8	-	3±0.05	M6	9	M16x1	G ¹ / ₈	78.5	30	77
40	80.5	45	110.3	-	4±0.05	M6	9	M22x1.5	G ¹ / ₄	99.5	41.5	97.5
63	123.5	68	146.3	-	9 ^{H7}	M10	9	M26x1.5	G ³ / ₈	153.5	48.5	151

∅ [mm]	H4 ±0.1	H5	H6	H7	H8	H9	H10	H11	H12 ±0.05	H13	H14	J1	J2
18	9.6	13.4	20	4.6	2.4	25.2	46	8.5±0.15	30	20	2.3	20	16.5
25	13.65	15.8	24	7.65	4.5	29	55.5	12±0.15	35	20	4.7	26.1	18.6
32	5.7	17	27.7	8.5	14	35.2	63.8	11.45±0.15	50	20	5.9	30	22
40	17.2	25	36.5	12.2	8	44	81.5	15±0.15	60	20	13.9	35	26
63	68	34.8	46	19.5	-	67	131	15.5±0.2	120	20	23.7	41.5	39.5

∅ [mm]	J3	L1		L2		L3	L4	L5	L6	L7		
		KF	KF-GP	KF	KF-GP					KF	KF-GP	KF-YSR(W)
18	11	150	157	74.5	78	5.7	5.8	15	5.5	14.5 ... 16.5	18 ... 20	14.5 ... 34.5
25	17	200	205	100	102.5	10.5	10.6	24.5	10.6	22.5 ... 26.5	25 ... 29	22.5 ... 47.5
32	18.5	250	250	124.8	124.8	14.5	14.5	30.5	14.5	27.3 ... 32.3	27.3 ... 32.3	27.3 ... 52.3
40	26	300	312	150	156	14.6	14.6	33.5	14.6	31 ... 36	37 ... 42	31 ... 56
63	31.5	400	-	200	-	20	20	44	20	41 ... 46	-	41 ... 76

∅ [mm]	L8		L9		L10 max.	T1	T2	T3 +0.2	T6	Stroke tolerance
	YSR	YSRW	KF ±0.2	KF-GP ±0.2						
18	29.9	32.6	-	3.5	119	9	2	3.1	15	0 ... 2.5
25	35.6	38.6	16.5	19	119	17.5	2	2.1	17.3	
32	19.5	28	35.3	35.3	119	15	2	2.1	20	
40	38.5	43.5	17	23	119	20	2	2.1	25.7	
63	38.3	48.3	97	-	119	27.5	2.1 ^{+0.2}	2.1	36.1	

Note

For reasons of functional safety of the displacement encoder and stability of the linear drive DGCI, the distance L7 must not fall below the values in the table.

Linear drives DGCI, with displacement encoder

Technical data

FESTO

Dimensions

Download CAD Data → www.festo.com/us/cad

Slide

Ø 18

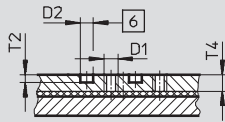

View A

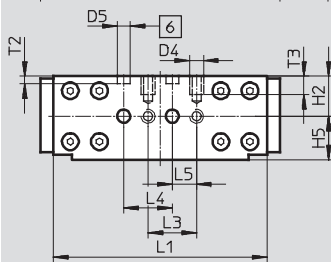
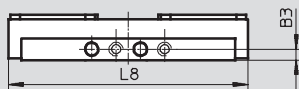

Ø 25

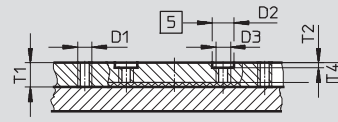

View A

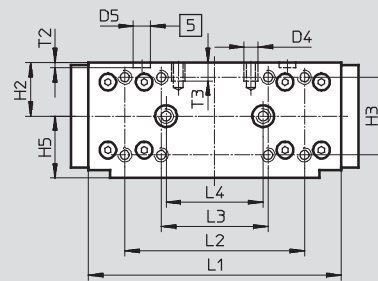
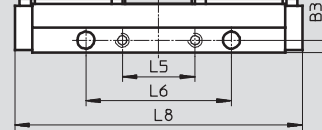

Ø 32

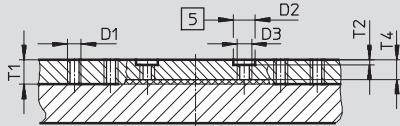

View A

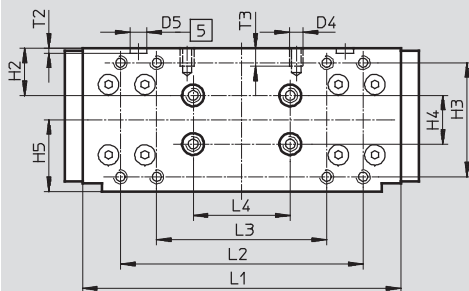
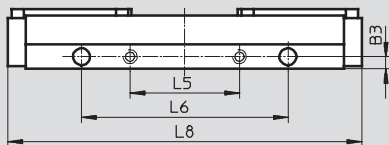

Ø 40

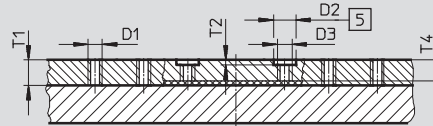

View A

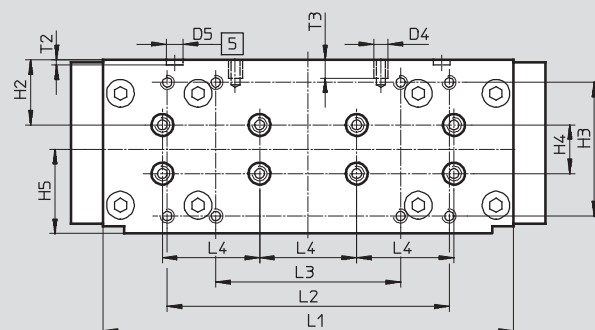
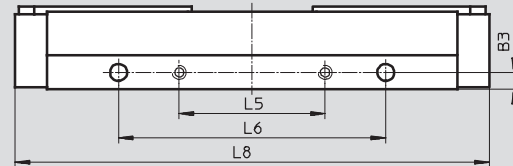

- 5 Hole for centring sleeve ZBH
- 6 Hole for centring pin ZBS

Linear drives DGCI, with displacement encoder

Technical data

FESTO

Dimensions

Download CAD Data → www.festo.com/us/cad

Slide

Ø 63

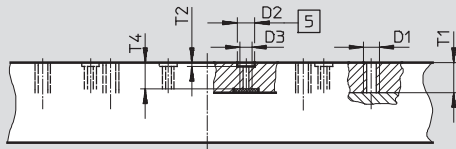

View A

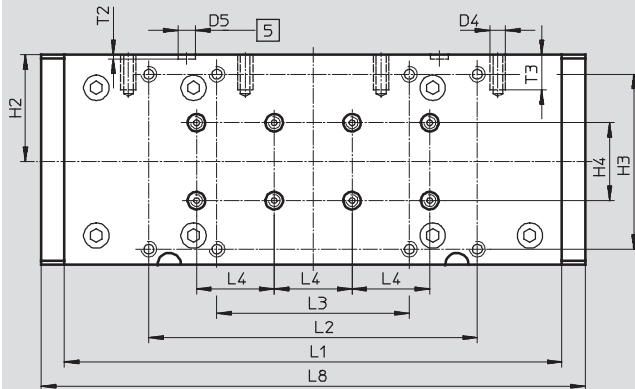
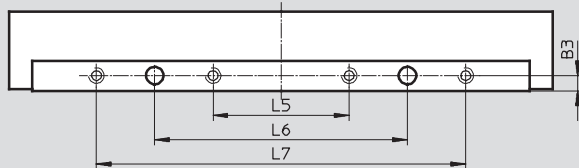

5 Hole for centring sleeve ZBH

6 Hole for centring pin ZBS

Ø	B3	D1	D2	D3	D4	D5	H2	H3	H4	H5	L1
[mm]	±0.05		Ø H7			Ø H7			±0.03	±0.1	
18	4.5	M5	5	-	M5	5	16.5	-	-	18	88±0.1
25	5	M5	9	M6	M5	7	22	32±0.2	-	25.5	104±0.2
32	5	M5	9	M6	M5	7	19.5	47±0.2	20	29.5	131±0.2
40	7	M5	9	M6	M6	7	26.8	55±0.2	20	34.7	169±0.2
63	8	M8	9	M6	M8	9	55	90±0.3	40	-	256±0.1

Ø	L2	L3	L4	L5	L6	L7	L8	T1	T2	T3	T4
[mm]	±0.2		±0.03	±0.1	±0.05	±0.1					
18	-	20±0.1	20	10	-	-	99	-	3.1±0.1	7.5	6.7
25	74	44±0.2	40	30	60	-	118.5	10	2.1±0.2	7.5	8
32	100	70±0.2	40	45	85	-	145.7	10	2.1±0.2	7.5	8
40	116	76±0.2	40	60	110	-	195.4	10.5	2.1±0.2	7.5	8.5
63	169	99±0.2	40	70	130	190	280	15.5	2.1±0.2	18	13.6

Linear drives DGCI, with displacement encoder

Technical data

FESTO

Dimensions

Download CAD Data → www.festo.com/us/cad

Slide, variant GP – Protected recirculating ball bearing guide

Ø 18

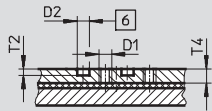

View A

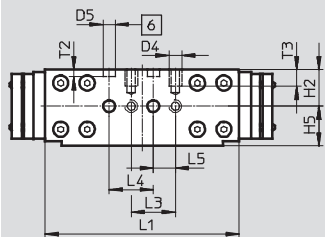
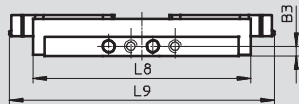

Ø 25

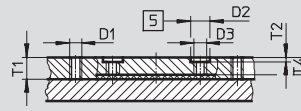

View A

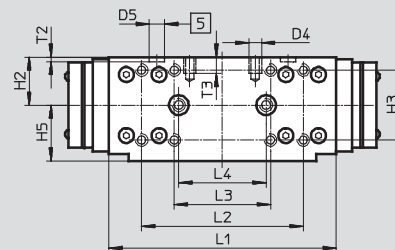
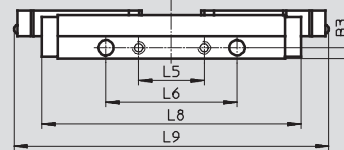

Ø 32

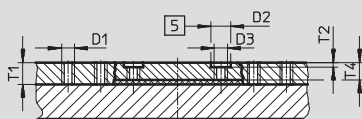

View A

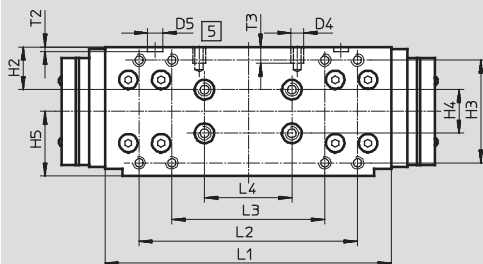
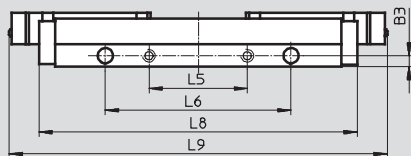

Ø 40

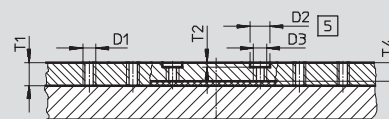

View A

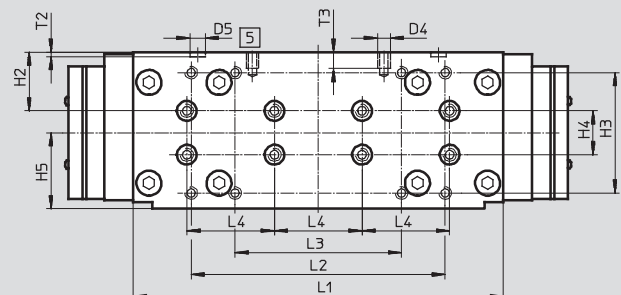
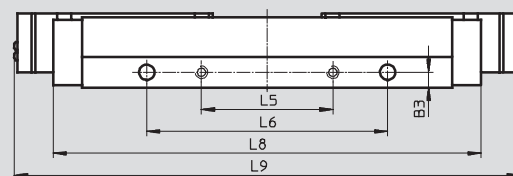

5 Hole for centring sleeve ZBH

6 Hole for centring pin ZBS

Linear drives DGCI, with displacement encoder

Technical data

∅ [mm]	B3 ±0.05	D1	D2 ∅ H7	D3	D4	D5 ∅ H7	H2	H3
18	4.5	M5	5	-	M5	5	16.5	-
25	5	M5	9	M6	M5	7	22	32±0.2
32	5	M5	9	M6	M5	7	19.5	47±0.2
40	7	M5	9	M6	M6	7	26.8	55±0.2

∅ [mm]	H4 ±0.03	H5 ±0.1	L1	L2 ±0.2	L3	L4 ±0.03	L5 ±0.1	L6 ±0.05
18	-	18	88±0.1	-	20±0.1	20	10	-
25	-	25.5	104±0.2	74	44±0.2	40	30	60
32	20	29.5	131±0.2	100	70±0.2	40	45	85
40	20	34.7	169±0.2	116	76±0.2	40	60	110

∅ [mm]	L8	L9	T1	T2	T3	T4
18	99	120	-	3.1±0.1	7.5	6.7
25	118.5	144	10	2.1±0.2	7.5	8
32	145.7	173	10	2.1±0.2	7.5	8
40	195.4	231	10.5	2.1±0.2	7.5	8.5

Linear drives DGCI, with displacement encoder

Technical data

FESTO

Dimensions

Download CAD Data → www.festo.com/us/cad

Slide, variant C – Lubrication adapter

Ø 25

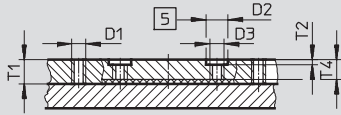

View A

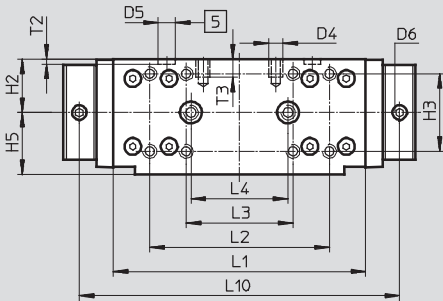
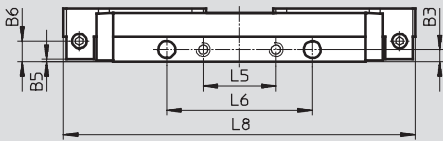

Ø 32

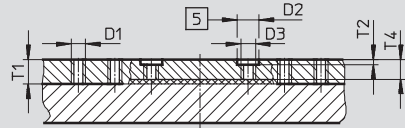

View A

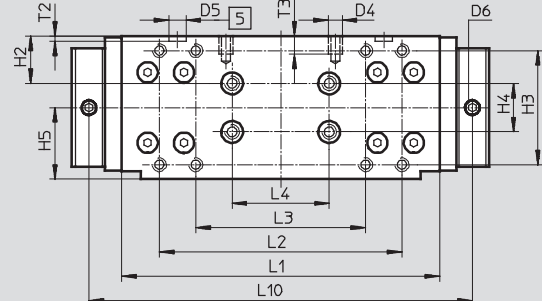
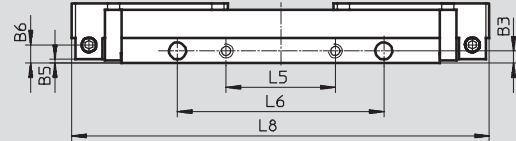

Ø 40

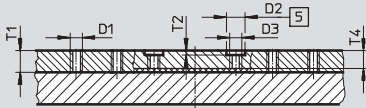

View A

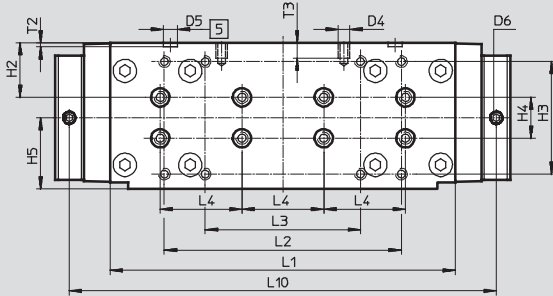
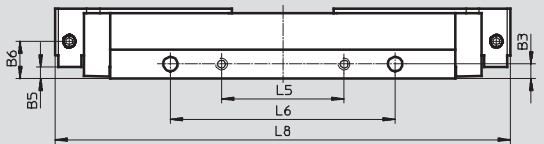

Ø 63

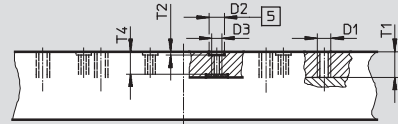

View A

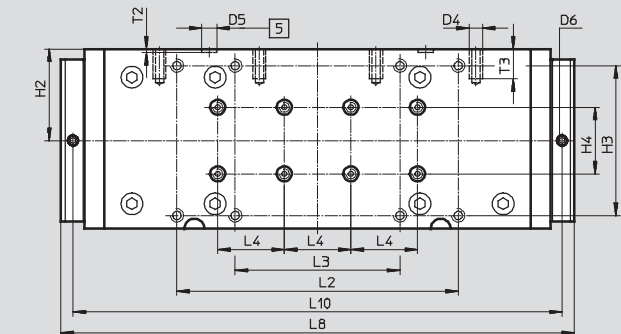
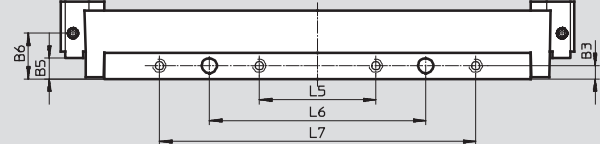

 Hole for centring sleeve ZBH

Linear drives DGCI, with displacement encoder

FESTO

Technical data

∅	B3	B5	B6	D1	D2 ∅ H7	D3	D4	D5 ∅ H7	D6	H2	H3	H4	H5
[mm]	±0.05	±0.05										±0.03	±0.1
25	5	1	8.5	M5	9	M6	M5	7	M6x1	22	32±0.2	-	25.5
32	5	1.5	7.5	M5	9	M6	M5	7	M6x1	19.5	47±0.2	20	29.5
40	7	18.2	18.2	M5	9	M6	M6	7	M6x1	26.8	55±0.2	20	34.7
63	8	12.5	27.5	M8	9	M6	M8	9	M6x1	55	90±0.3	40	-

∅	L1	L2	L3	L4	L5	L6	L7	L8	L10	T1	T2	T3	T4
[mm]		±0.2	±0.2	±0.03	±0.1	±0.05	±0.1				+0.2		
25	104±0.2	74	44	40	30	60	-	145	132	10	2.1	7.5	8
32	131±0.2	100	70	40	45	85	-	172	158	10	2.1	7.5	8
40	169±0.2	116	76	40	60	110	-	223	209	10.5	2.1	7.5	8.5
63	256±0.1	169	99	40	70	130	190	308.4	293.8	15.5	2.1	18	13.6

Profile barrel

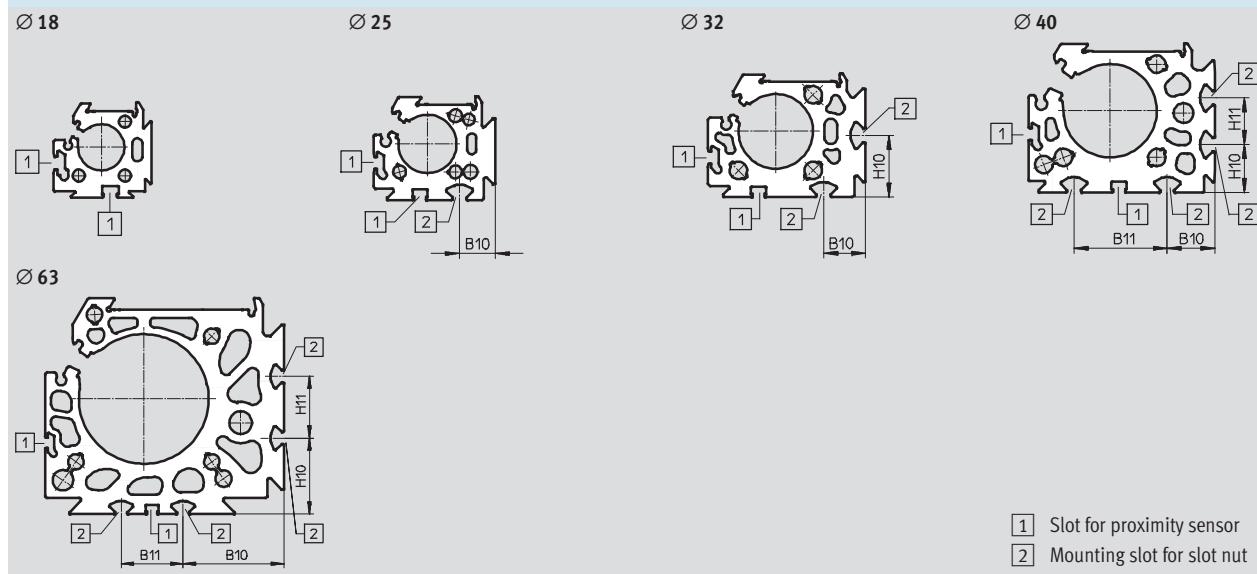

∅	B10	B11	H10	H11
[mm]				
25	15.23	-	-	-
32	18	-	26.5	-
40	20.5	40	20.5	20
63	49	30	37	30

Tube diameter with pre-assembled push-in fittings

Size	Stroke [mm]	∅ in [mm]			
		6	8	10	12
DGCI-18	100 ... 2,000	■	-	-	-
DGCI-25	100 ... 160	■	-	-	-
	225 ... 2,000	-	■	-	-
DGCI-32	100	■	-	-	-
	160 ... 2,000	-	■	-	-
DGCI-40	100 ... 750	-	■	-	-
	850 ... 2,000	-	-	■	-
DGCI-63	100 ... 300	-	■	-	-
	360 ... 500	-	-	■	-
	600 ... 2,000	-	-	-	■

Linear drives DGCI, with displacement encoder

Ordering data – Modular products

Order code

Mandatory data/options

Note

Drive must not be operated without end stops or shock absorbers.

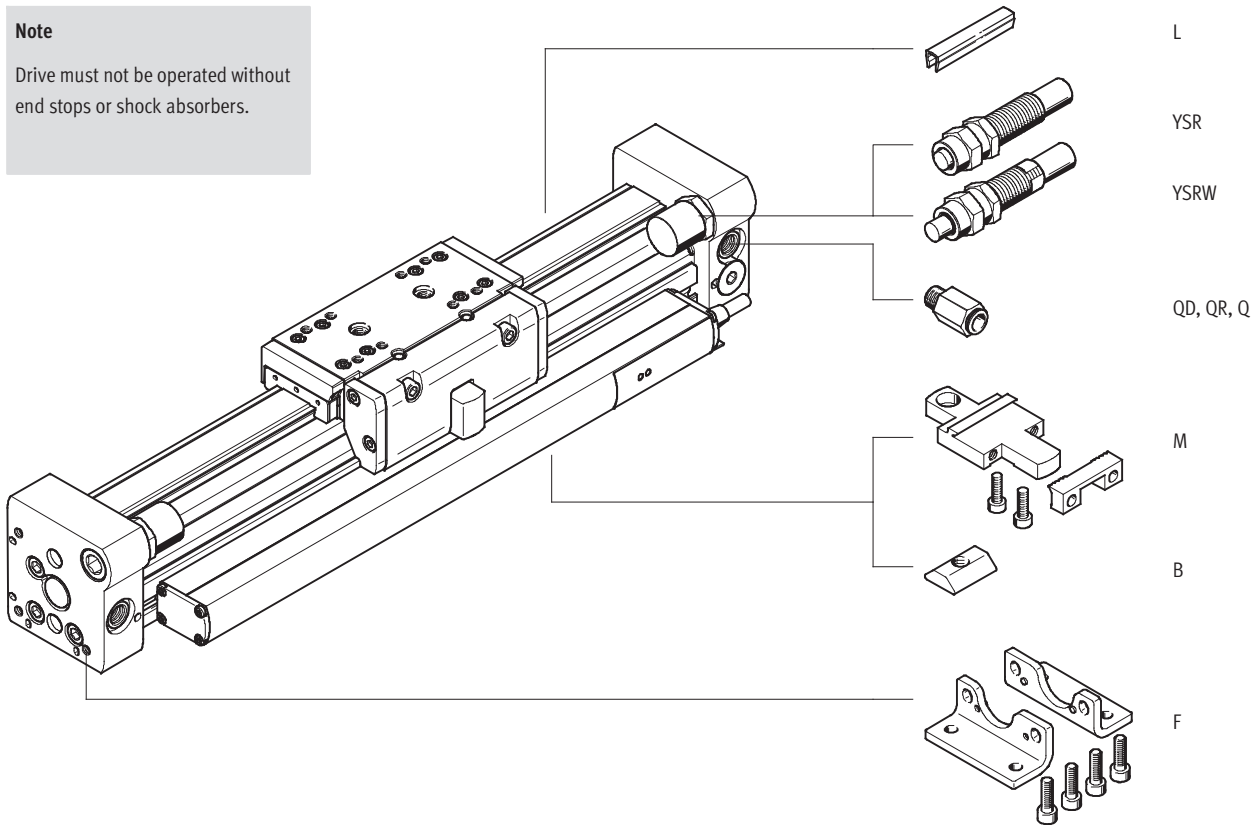

Effective stroke reduction when ordering an additional slide KL or KR

For a linear drive DGCI with additional slide, the effective stroke is reduced by the length of the additional slide and the distance between both slides.

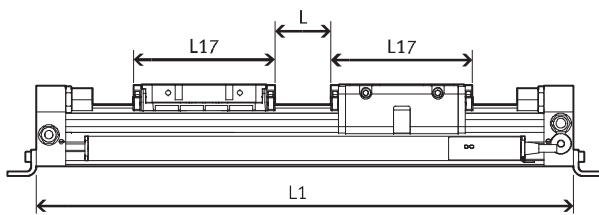

∅ [mm]	L17	
	DGCI-...-KF	DGCI-...-KF-...-GP
18	99	120
25	118.5	144
32	145.7	173
40	195.4	231
63	280	-

Given:

DGCI-18-500-...

L = 20 mm

L17= 99 mm

The effective stroke is reduced to

$$381 \text{ mm} = 500 \text{ mm} - 20 \text{ mm} - 99 \text{ mm}$$

Linear drives DGCI, with displacement encoder

Ordering data – Modular products



Order code – Alternative supply port

Four different supply port options (see below) can be selected when ordering the linear drive.

To make commissioning easier, the linear drive is supplied with different

coloured push-in fittings (black or blue release ring) and without push-in

fittings in the case of the variant DGCI-...Q.

Push-in fitting at both ends, front (standard)
DGCI-...

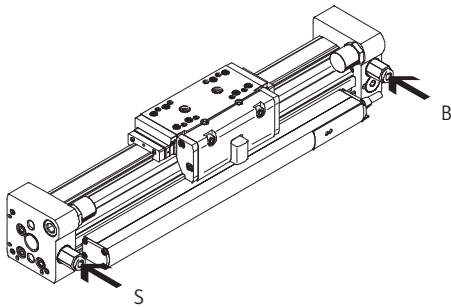

Push-in fitting at both ends, end face
DGCI-...-QD

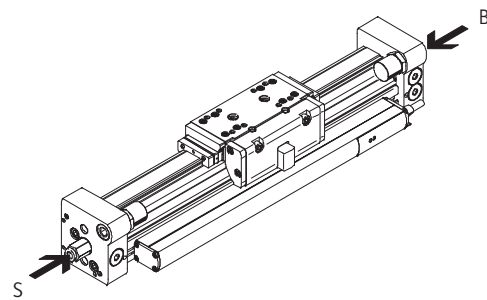

Push-in fitting at one end, end face
DGCI-...-QR

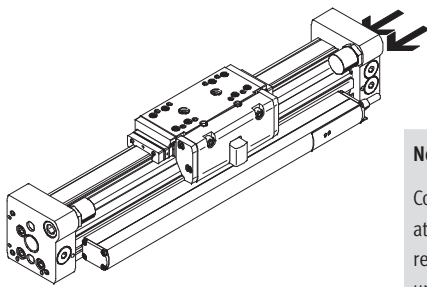

Note
Compressed air supply at one end is only recommended for strokes up to 600 mm.

No push-in fitting, end face open
DGCI-...Q

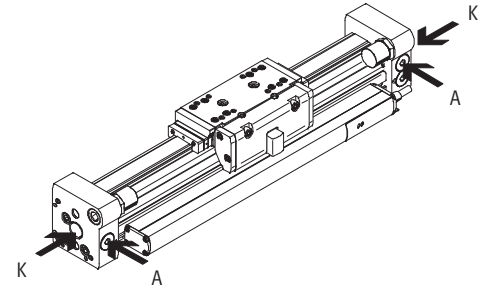

Direction of movement of the slide

S To the right: Fitting with black release ring
B To the left: Fitting with blue release ring

Alternative port option

K Supply ports open A Supply ports sealed

Order code

KL/KR – With additional slide

GP – With protected recirculating ball bearing guide

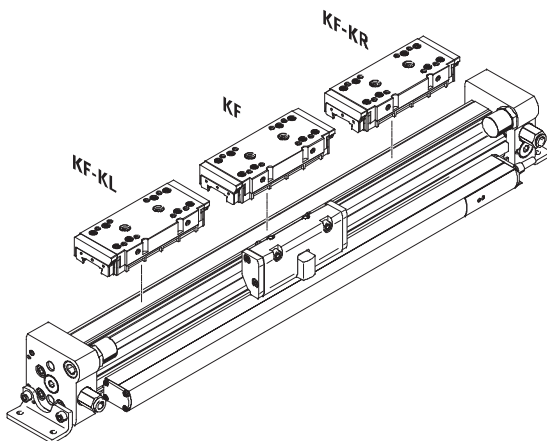

Note
In the case of the variant with GP, only fixed stops may be used in the end caps. Shock absorbers may only be used in combination with the shock absorber retainer DADP-DGC.

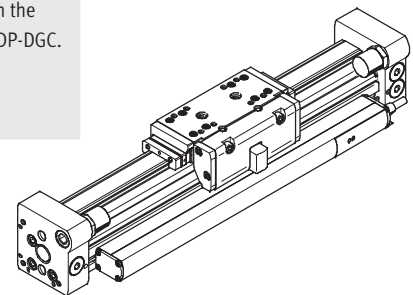

Linear drives DGCI, with displacement encoder

Ordering data – Modular products

M Mandatory data					O Options →
Module No.	Function	Piston Ø	Stroke	Guide	Alternative supply port
544 425	DGCI	18	100; 160; 225; 300;	KF	– QD QR Q
544 426		25	360; 450; 500; 600;		
544 427		32	750;		
544 428		40	850; 1,000; 1,250;		
544 429		63	1,500; 1,750; 2,000		
Ordering example					
	DGCI	–	–	KF	–

Ordering table								
Size	18	25	32	40	63	Conditions	Code	Enter code
M Module No.	544 425	544 426	544 427	544 428	544 429			
Function	Linear drive with displacement encoder						DGCI	DGCI
Piston Ø [mm]	18	25	32	40	63		-...	
Stroke [mm]	100; 160; 225; 300; 360; 450; 500; 600; 750; 850; 1,000; 1,250; 1,500; 1,750; 2,000						-...	
Guide	Recirculating ball bearing guide						-KF	-KF
O Alternative supply port	Push-in fitting at both ends, front face (standard)							
	Push-in fitting at both ends, end face						-QD	
	Push-in fitting at one end, end face, right side					1	-QR	
	Threaded connection (end face open, front face sealed)						-Q	
	M5	G1/8	G1/8	G1/4	G3/8			

1 QR Only for strokes 100 ... 600 mm

Transfer order code

New
Lubrication adapter

Linear drives DGCI, with displacement encoder

Ordering data – Modular products



Options									
Slide	Lubrication function	Additional slide on left	Additional slide on right	Cushioning	Accessories	Type of mounting	Slot cover for sensor slot	Slot nut for mounting slot	Manual
GP	C	KL	KR	– YSR YSRW	ZUB	F M	...L	...B	0
-	-	-	-	-	ZUB	-	-	-	-

Ordering table											
Size	18	25	32	40	63	Conditions	Code	Enter code			
Slide	Protected recirculating ball bearing guide					-	[2]	-GP			
Lubrication function	Standard										
	-	Lubrication adapter							-C		
Additional slide on left	Additional slide, standard, on left						[3]	-KL			
Additional slide on right	Additional slide, standard, on right						[3]	-KR			
Cushioning	Adjustable mechanical stop without cushioning (standard)										
	Shock absorber, self-adjusting							-YSR			
	Shock absorber, self-adjusting, progressive							-YSRW			
Accessories								ZUB-	ZUB-		
Type of mounting	Foot mounting (includes 0 ... 2 profile mountings depending on the stroke)						[4]	F			
	Profile mounting (2 ... 4 depending on the stroke)						[4]	M			
Slot cover for sensor slot	1 ... 9							...L			
Slot nut for mounting slot	-	1 ... 9							...B		
Manual	Express waiver - no operating instructions to be included (already available) (operating instructions in PDF format are available free of charge on our website at www.festo.com)							0			

- [2] **GP** Not with YSR, YSRW and C
Not with additional slide on left KL or additional slide on right KR
- [3] **KL, KR** For a linear drive DGCI with additional slide (KL, KR), the effective stroke per additional slide is reduced by the dimension in the table → 55 plus the distance between the slides.
If the slide with lubrication adapter C is selected, then the additional slide (KL, KR) is also supplied with lubrication adapter
- [4] **F, M** Allocation table → 44

Transfer order code

- [] - [] - [] - [] - [] - ZUB - [] - [] - [] - []

Linear drives DGCI, with displacement encoder

FESTO

Accessories

Foot mounting HPC
(order code: F)

Material:
Galvanised steel

Note

Additional profile mountings MUC are required for strokes above 400 mm → 44.

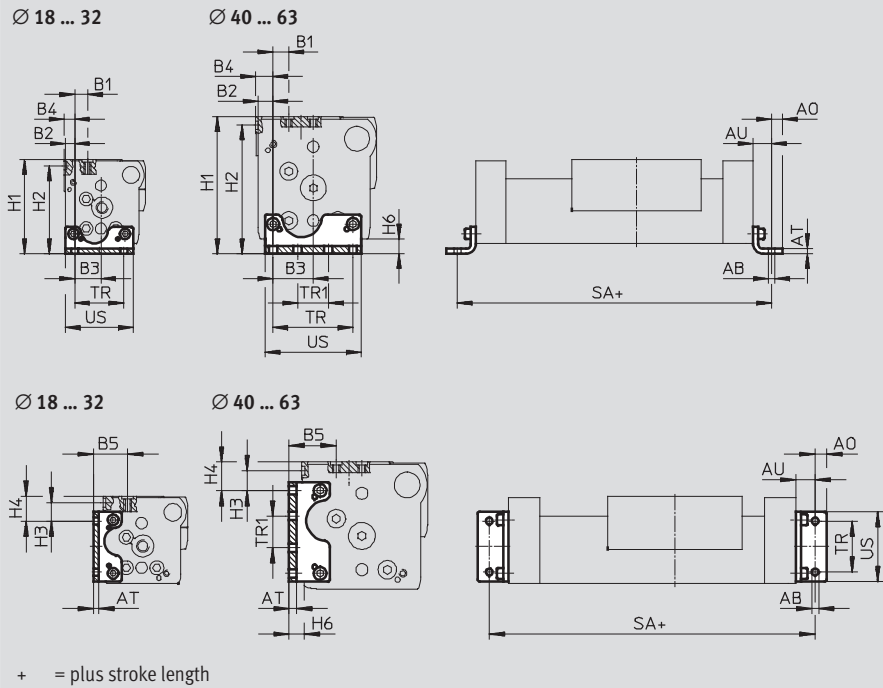

Dimensions and ordering data

For Ø [mm]	AB Ø	A0	AT	AU	B1	B2	B3
18	5.5	6.75	3	13.25	11.2	4.3	15.2
25	5.5	9	4	15	13.35	7.65	22.35
32	6.6	10	5	19	9	9	29.5
40	6.6	10	6	20	12.6	12.2	32.8
63	11	13.5	8	28	17.5	12.5	55.5

For Ø [mm]	B4	B5	H1	H2	H3	H4
18	5.3	23.2	64	59.5	16	21.5
25	8.65	29.5	76.5	71.5	14.35	19.35
32	10.5	27	87.5	82.5	8	13
40	14.2	36.8	111.5	104.5	15.3	22.3
63	17.5	49	172.5	164.5	22	30

For Ø [mm]	H6	SA	TR ±0.1	TR1 ±0.1	US	Weight [g]	Part No.	Type
18	7.7	176.5	30	–	38.6	58	533 667	HPC-18
25	8.5	230	40	–	55	131	533 668	HPC-25
32	9	288	56.5	19.5	68	239	533 669	HPC-32
40	12	340	65	25	78	348	533 670	HPC-40
63	19	456	111	39	133	1,245	545 237	HPC-63

Linear drives DGCI, with displacement encoder

Accessories

Profile mounting MUC
(order code: M)

Material:
High-alloy steel

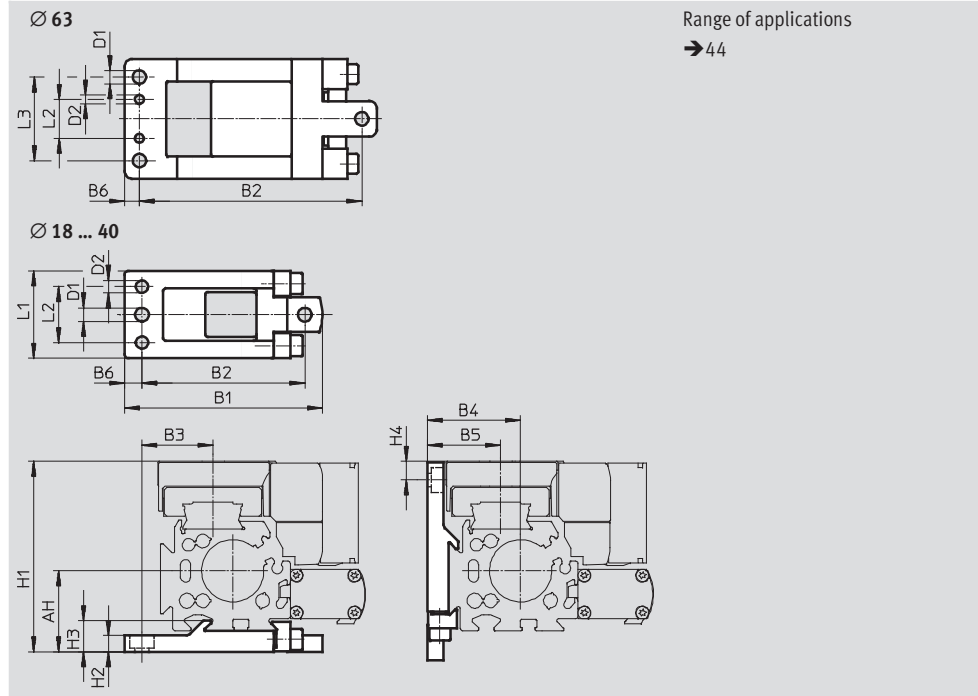

Dimensions and ordering data									
For Ø	AH	B1	B2	B3	B4	B5	B6	D1	D2
[mm]			±0.2					Ø H13	Ø H7
18	27.2	67.8±0.2	56±0.15	28.7	27.2	23.2	5.7	5.5	5
25	32.5	79.5±0.2	65.5±0.15	28.5	37.5	29.5	7	5.5	5
32	37.5	94±0.2	80±0.15	35	47.5	37	7	5.5	5
40	47	110.5±0.2	96±0.15	43	57	46.8	7	6.5	6
63	75	169±0.5	149±0.2	72.5	87	69	10	9	6

For Ø	H1	H2	H3	H4	L1	L2	L3	Weight	Part No.	Type
[mm]						±0.05	±0.2	[g]		
18	64	5.7 _{-0.2}	9.9±0.1	6.4	33±0.1	20.5	-	78	531 752	MUC-18
25	76.5	6.5 _{-0.2}	12.5±0.1	7.43	35±0.1	22.5	-	113	531 753	MUC-25
32	87.5	6.5 _{-0.2}	13±0.1	4	45±0.1	30	-	174	531 754	MUC-32
40	111.5	8.5 _{-0.2}	16±0.1	11.3	60±0.1	44	-	346	531 755	MUC-40
63	172.5	11	25.5	15	80±0.4	26	56	1,080	531 757	MUC-63

Linear drives DGCI, with displacement encoder

Accessories

Shock absorber retainer DADP-DGC Stop KYC

Materials: Stop
Housing: Anodised aluminium
Stop bracket: Stainless steel casting
Clamp: High-alloy steel
Free of copper and PTFE

Materials: Shock absorber retainer
Housing: Anodised aluminium
Free of copper and PTFE

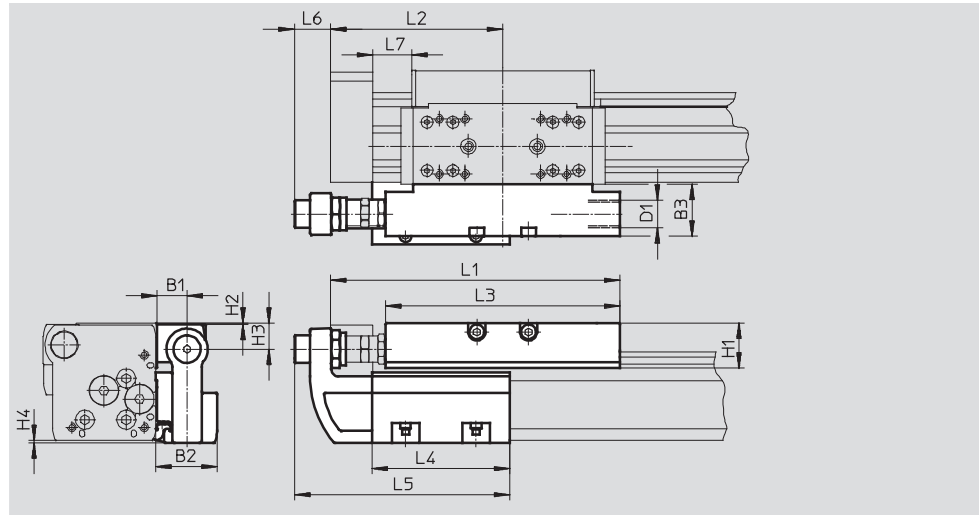

Note
Shock absorbers are not included in the scope of delivery. Existing stop elements can be removed from the end caps of the linear drive and installed in the shock absorber retainer.

Dimensions									
For Ø	B1	B2	B3	D1	H1	H2	H3	H4	L1
[mm]									
18	16	34.5	29	M12x1	20.7	0.2	12.5	0.7	128
25	16.5	35	30	M16x1	25.5	0.5	15	1.4	168
32	16.5	35	30	M16x1	25.5	0.5	15	1.7	206.8
40	16	35.7	35	M22x1.5	37	0.5	21.5	2	255
63	25	50	40	M26x1.5	51.5	1.5	33	0	328

For Ø	L2	L3	L4	L5	L6	L7		
						KF	KF-GP	KF-YSR(W)
[mm]								
18	74.5	107	80	118.5	23.5	≥14.5	≥18	≥14.5
25	100	136	80	125	20.5	≥22.5	≥25	≥22.5
32	124.8	164	120	165	14.5	≥27.3	≥27.3	≥27.3
40	150	210	156	220.5	31	≥31	≥37	≥31
63	200	256	200	268	24	≥41	-	≥41

Note
For reasons of functional safety of the displacement encoder and stability of the linear drive DGCI, the distance L7 must not fall below the values in the table.

Linear drives DGCI, with displacement encoder

Accessories

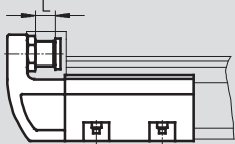
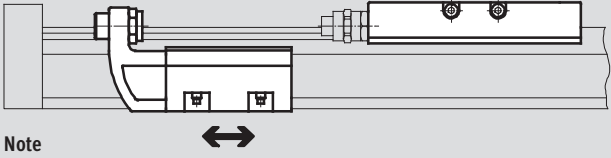
Technical data and ordering data	Installation example
<p>Precision adjustment</p>  <p>Note</p> <p>The stop KYC can be used in both directions.</p>	 <p>Note</p> <ul style="list-style-type: none"> The stop KYC can be mounted at any position along the stroke. Note dimension L7 → 61.

For Ø [mm]	Max. impact force [N]	Ambient temperature [°C]	CRC ¹⁾	Weight [g]	Part No.	Type
Shock absorber retainer DADP-DGC						
18	1,100	-10 ... +80	2	130	541 729	DADP-DGC-18-KF
25	1,400			180	541 730	DADP-DGC-25-KF
32	1,700			215	541 731	DADP-DGC-32-KF
40	3,500			460	541 732	DADP-DGC-40-KF
63	4,300			1,080	545 245	DADP-DGC-63

1) Corrosion resistance class 2 according to Festo standard 940 070
 Components subject to moderate corrosion stress. Externally visible parts with primarily decorative surface requirements which are in direct contact with a normal industrial environment or media such as coolants or lubricating agents.

For Ø [mm]	Precision adjustment L [mm]	Ambient temperature [°C]	CRC ¹⁾	Weight [g]	Part No.	Type
Stop KYC						
18	10	-10 ... +80	2	400	541 691	KYC-18
25	10			560	541 692	KYC-25
32	10			790	541 693	KYC-32
40	15			1,525	541 694	KYC-40
63	15			2,950	545 243	KYC-63

1) Corrosion resistance class 2 according to Festo standard 940 070
 Components subject to moderate corrosion stress. Externally visible parts with primarily decorative surface requirements which are in direct contact with a normal industrial environment or media such as coolants or lubricating agents.

Note

Permissible impact energy
 → 42

Linear drives DGCI, with displacement encoder

Accessories

Intermediate position module DADM-DGC



Materials:
Housing: Anodised aluminium
Stop screw, nut:
Galvanised steel

Clamp, lever:
High-alloy steel
Free of copper and PTFE

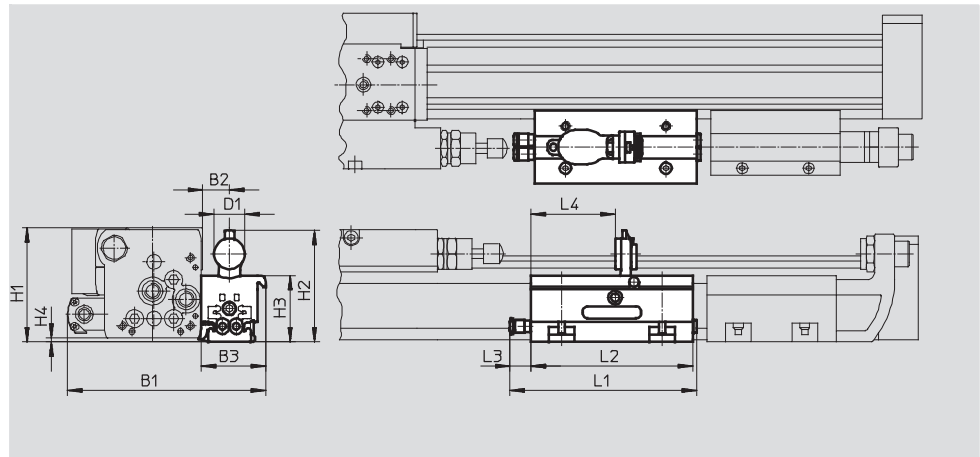

Note

- Shock absorbers are not included in the scope of delivery. Existing shock absorbers can be removed from the end caps of the linear drive and installed in the shock absorber retainer. Under no circumstances may the linear drive and the intermediate position module be operated without a shock absorber.
- A shock absorber retainer DADP-DGC and a stop KYC are additionally needed when using an intermediate position module.
- The projection (dimension H4) must be observed when using the drive in combination with the intermediate position module DADM-DGC. Mounting via foot mountings HPC or profile mountings MUC is recommended in this case.

Dimensions						
For Ø [mm]	B1	B2	B3	D1	H1	H2
25	122.5	16.5	40	19	69.4	68.6
32	138	16.5	40	19	80.2	79.7

For Ø [mm]	H3	H4	L1	L2	L3	L4
25	41	1.4	116	100	13.4	52.2
32	52	1.7	116	100	13.4	52.2

Note

Permissible impact energy
→ 42

Linear drives DGCI, with displacement encoder

Accessories

Minimum distance

Between end stop and intermediate position

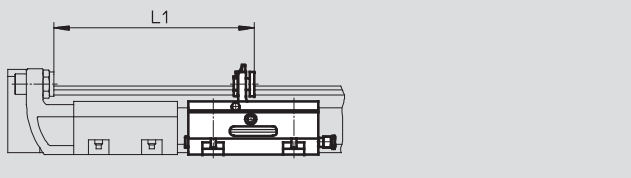

∅	L1
25	145.3
32	185.3

Between two intermediate positions

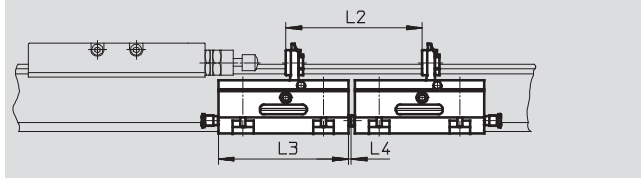

∅	L2	L3	L4
25	105	100	2.5
32	105	100	2.5

Technical data and ordering data

Precision adjustment L

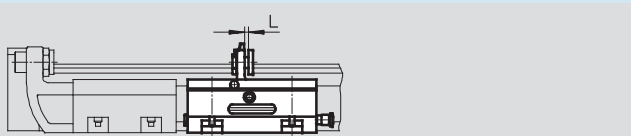

Note

The intermediate position module DADM-DGC can be used in both directions. A shock absorber retainer DADP-DGC and a stop KYC are additionally needed when using an intermediate position module.

Installation example

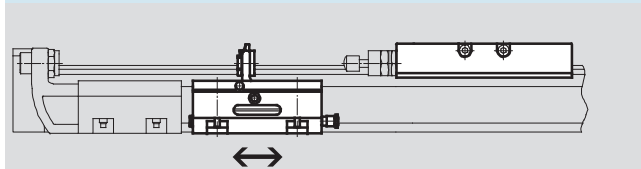

Note

The intermediate position module DADM-DGC can be mounted at any position along the stroke.

For ∅ [mm]	Operating pressure [bar]	Impact velocity [m/s]	Swivel time [ms]	Repetition accuracy [mm]	Pneumatic connection	Precision adjustment L [mm]
25	2.5 ... 8	→ 45	<100	0.02	QS-4	2
32						



For ∅ [mm]	Ambient temperature [°C]	CRC ¹⁾	Mounting position	Position sensing	Weight [g]	Part No.	Type
25	-10 ... +60	2	Any	Via proximity sensor SME/SMT-10	430	541 700	DADM-DGC-25-A
32					530	541 701	DADM-DGC-32-A

1) Corrosion resistance class 2 according to Festo standard 940 070

Components subject to moderate corrosion stress. Externally visible parts with primarily decorative surface requirements which are in direct contact with a normal industrial environment or media such as coolants or lubricating agents.

Linear drives DGCI, with displacement encoder

Accessories

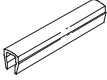
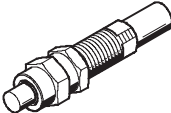
Ordering data						
	For Ø	Comment	Order code	Part No.	Type	PU ¹⁾
Slot nut HMBN Technical data → Internet: hmbn						
	25 ... 40	For mounting slot	B	547 264	HMBN-5-1M5	10
	63			186 566	HMBN-5-2M5	
Centring pin/sleeve ZBS, ZBH Technical data → Internet: zbs, zbh						
	18	For slide	-	150 928	ZBS-5	10
	25 ... 63			150 927	ZBH-9	
	18	For end cap		150 928	ZBS-5	
	25 ... 63			150 927	ZBH-9	
Slot cover ABP-S Technical data → Internet: abp						
	18 ... 63	For sensor slot, every 0.5 m	L	151 680	ABP-5-S	2
Shock absorber YSRW Technical data → Internet: ysrw						
	18		YSRW	540 347	YSRW-DGC-18-KF	1
	25			540 349	YSRW-DGC-25-KF	
	32			540 351	YSRW-DGC-32-KF	
	40			1232870	YSRW-DGC-40/50-B	
	63			543 069	YSRW-DGC-63	

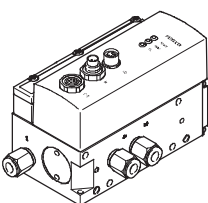
Ordering data – Proportional directional control valves and push-in fittings						
	For Ø [mm]	Stroke [mm]	Proportional directional control valve		Push-in fitting for DGCI	
			Part No.	Type	Part No.	Type
For applications with axis controller CPX-CMAX						
	18	100 ... 300	1)	VPWP-2	153 306	QSM-M5-6
		360 ... 2,000	550 170	VPWP-4-L-5-Q6-10-E-...	153 306	QSM-M5-6
	25	100 ... 160	1)	VPWP-2	153 002	QS-1/8-6
		225 ... 750	550 170	VPWP-4-L-5-Q8-10-E-...	153 004	QS-1/8-8
		850 ... 2,000	550 171	VPWP-6-L-5-Q8-10-E-...	153 004	QS-1/8-8
	32	100	1)	VPWP-2	153 002	QS-1/8-6
		160 ... 360	550 170	VPWP-4-L-5-Q8-10-E-...	153 004	QS-1/8-8
		450 ... 2,000	550 171	VPWP-6-L-5-Q8-10-E-...	153 004	QS-1/8-8
	40	100 ... 300	550 170	VPWP-4-L-5-Q8-10-E-...	153 005	QS-1/4-8
		360 ... 750	550 171	VPWP-6-L-5-Q8-10-E-...	153 005	QS-1/4-8
		850 ... 2,000	550 172	VPWP-8-L-5-Q10-10-E-...	153 007	QS-1/4-10
	63	100 ... 160	550 170	VPWP-4-L-5-Q8-10-E-...	153 006	QS-3/8-8
225 ... 300		550 171	VPWP-6-L-5-Q8-10-E-...	153 006	QS-3/8-8	
360 ... 450		550 172	VPWP-8-L-5-Q10-10-E-...	153 008	QS-3/8-10	
500 ... 2,000		1)	VPWP-10	153 009	QS-3/8-12	

1) On request

Linear drives DGCI, with displacement encoder

Accessories

Ordering data – Proportional directional control valves and push-in fittings					
For Ø [mm]	Stroke [mm]	Proportional directional control valve		Push-in fitting for DGCI	
		Part No.	Type	Part No.	Type
For applications with Soft Stop end-position controller CPX-CMPX, horizontal					
18	100 ... 300	1)	VPWP-2	153 306	QSM-M5-6
	360 ... 1,750	550 170	VPWP-4-L-5-Q6-10-E-...	153 306	QSM-M5-6
	2,000	550 171	VPWP-6-L-5-Q-10-E-...	153 306	QSM-M5-6
25	100 ... 160	550 170	VPWP-4-L-5-Q6-10-E-...	153 002	QS-1/8-6
	225 ... 300	550 170	VPWP-4-L-5-Q8-10-E-...	153 004	QS-1/8-8
	360 ... 2,000	550 171	VPWP-6-L-5-Q8-10-E-...	153 004	QS-1/8-8
32	100	550 170	VPWP-4-L-5-Q6-10-E-...	153 002	QS-1/8-6
	160 ... 1,000	550 171	VPWP-6-L-5-Q8-10-E-...	153 004	QS-1/8-8
	1,250 ... 2,000	550 172	VPWP-8-L-5-Q-10-E-...	153 004	QS-1/8-8
40	100 ... 500	550 171	VPWP-6-L-5-Q8-10-E-...	153 005	QS-1/4-8
	600 ... 750	550 172	VPWP-8-L-5-Q-10-E-...	153 005	QS-1/4-8
	850 ... 2,000	550 172	VPWP-8-L-5-Q10-10-E-...	153 007	QS-1/4-10
63	100 ... 160	550 170	VPWP-4-L-5-Q8-10-E-...	153 006	QS-3/8-8
	225 ... 300	550 171	VPWP-6-L-5-Q8-10-E-...	153 006	QS-3/8-8
	360 ... 450	550 172	VPWP-8-L-5-Q10-10-E-...	153 008	QS-3/8-10
	500 ... 2,000	1)	VPWP-10	153 009	QS-3/8-12
For applications with Soft Stop end-position controller CPX-CMPX, vertical					
18	100 ... 300	1)	VPWP-2	153 306	QSM-M5-6
	360 ... 1,750	550 170	VPWP-4-L-5-Q6-10-E-...	153 306	QSM-M5-6
	2,000	550 171	VPWP-6-L-5-Q-10-E-...	153 306	QSM-M5-6
25	100 ... 160	550 170	VPWP-4-L-5-Q6-10-E-...	153 002	QS-1/8-6
	225 ... 750	550 170	VPWP-4-L-5-Q8-10-E-...	153 004	QS-1/8-8
	850 ... 2,000	550 171	VPWP-6-L-5-Q8-10-E-...	153 004	QS-1/8-8
32	100	550 170	VPWP-4-L-5-Q6-10-E-...	153 002	QS-1/8-6
	160 ... 300	550 170	VPWP-4-L-5-Q8-10-E-...	153 004	QS-1/8-8
	360 ... 1,750	550 171	VPWP-6-L-5-Q8-10-E-...	153 004	QS-1/8-8
	2,000	550 172	VPWP-8-L-5-Q-10-E-...	153 004	QS-1/8-8
40	100 ... 225	550 170	VPWP-4-L-5-Q8-10-E-...	153 005	QS-1/4-8
	300 ... 750	550 171	VPWP-6-L-5-Q8-10-E-...	153 005	QS-1/4-8
	850 ... 1,000	550 171	VPWP-6-L-5-Q-10-E-...	153 007	QS-1/4-10
	1,250 ... 2,000	550 172	VPWP-8-L-5-Q10-10-E-...	153 007	QS-1/4-10
63	100 ... 160	550 170	VPWP-4-L-5-Q8-10-E-...	153 006	QS-3/8-8
	225 ... 300	550 171	VPWP-6-L-5-Q8-10-E-...	153 006	QS-3/8-8
	360 ... 450	550 172	VPWP-8-L-5-Q10-10-E-...	153 008	QS-3/8-10
	500 ... 2,000	1)	VPWP-10	153 009	QS-3/8-12

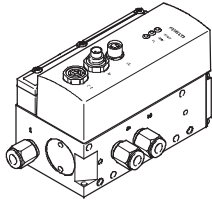

1) On request

Linear drives DGCI, with displacement encoder

Accessories

FESTO

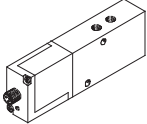
Ordering data – Proportional directional control valves and push-in fittings			Proportional directional control valve Technical data → Internet: mpye Part No. Type		Push-in fitting for DGCI Technical data → Internet: quick star Part No. Type	
	For Ø [mm]	Stroke [mm]				
	For applications with axis controller SPC200					
	18	100 ... 300	154 200	MPYE-5-M5-010-B	153 306	QSM-M5-6
		360 ... 2,000	151 692	MPYE-5-1/8-LF-010-B	153 306	QSM-M5-6
	25	100 ... 160	154 200	MPYE-5-M5-010-B	153 002	QS-1/8-6
		225 ... 750	151 692	MPYE-5-1/8-LF-010-B	153 004	QS-1/8-8
		850 ... 2,000	151 693	MPYE-5-1/8-HF-010-B	153 004	QS-1/8-8
	32	100	154 200	MPYE-5-M5-010-B	153 002	QS-1/8-6
		160 ... 360	151 692	MPYE-5-1/8-LF-010-B	153 004	QS-1/8-8
		450 ... 2,000	151 693	MPYE-5-1/8-HF-010-B	153 004	QS-1/8-8
	40	100 ... 300	151 692	MPYE-5-1/8-LF-010-B	153 005	QS-1/4-8
		360 ... 750	151 693	MPYE-5-1/8-HF-010-B	153 005	QS-1/4-8
		850 ... 2,000	151 694	MPYE-5-1/4-010-B	153 007	QS-1/4-10
	63	100 ... 160	151 692	MPYE-5-1/8-LF-010-B	153 006	QS-3/8-8
		225 ... 300	151 693	MPYE-5-1/8-HF-010-B	153 006	QS-3/8-8
		360 ... 450	151 694	MPYE-5-1/4-010-B	153 008	QS-3/8-10
500 ... 2,000		151 695	MPYE-5-3/8-010-B	153 009	QS-3/8-12	

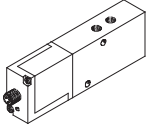
Ordering data – Proportional directional control valves and push-in fittings			Proportional directional control valve Technical data → Internet: mpye Part No. Type		Push-in fitting for DGCI Technical data → Internet: quick star Part No. Type	
	For Ø [mm]	Stroke [mm]				
	For applications with Soft Stop end-position controller SPC11-MTS-A1F-2, horizontal					
	18	100 ... 300	154 200	MPYE-5-M5-010-B	153 306	QSM-M5-6
		360 ... 1,750	151 692	MPYE-5-1/8-LF-010-B	153 306	QSM-M5-6
		2,000	151 693	MPYE-5-1/8-HF-010-B	153 306	QSM-M5-6
	25	100 ... 160	151 692	MPYE-5-1/8-LF-010-B	153 002	QS-1/8-6
		225 ... 300	151 692	MPYE-5-1/8-LF-010-B	153 004	QS-1/8-8
		360 ... 2,000	151 693	MPYE-5-1/8-HF-010-B	153 004	QS-1/8-8
	32	100	151 692	MPYE-5-1/8-LF-010-B	153 002	QS-1/8-6
		160 ... 1,000	151 693	MPYE-5-1/8-HF-010-B	153 004	QS-1/8-8
		1,250 ... 2,000	151 694	MPYE-5-1/4-010-B	153 004	QS-1/8-8
	40	100 ... 500	151 693	MPYE-5-1/8-HF-010-B	153 005	QS-1/4-8
		600 ... 750	151 694	MPYE-5-1/4-010-B	153 005	QS-1/4-8
		850 ... 2,000	151 694	MPYE-5-1/4-010-B	153 007	QS-1/4-10
	63	100 ... 160	151 692	MPYE-5-1/8-LF-010-B	153 006	QS-3/8-8
		225 ... 300	151 693	MPYE-5-1/8-HF-010-B	153 006	QS-3/8-8
360 ... 450		151 694	MPYE-5-1/4-010-B	153 008	QS-3/8-10	
500 ... 2,000		151 695	MPYE-5-3/8-010-B	153 009	QS-3/8-12	

Linear drives DGCI, with displacement encoder

Accessories

FESTO

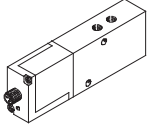
Ordering data – Proportional directional control valves and push-in fittings		Proportional directional control valve		Push-in fitting for DGCI		
		Technical data → Internet: mpye		Technical data → Internet: quick star		
	For Ø [mm]	Stroke [mm]	Part No.	Type	Part No.	Type
	For applications with Soft Stop end-position controller SPC11-MTS-AIF-2, vertical					
	18	100 ... 300	154 200	MPYE-5-M5-010-B	153 306	QSM-M5-6
		360 ... 1,750	151 692	MPYE-5-1/8-LF-010-B	153 306	QSM-M5-6
		2,000	151 693	MPYE-5-1/8-HF-010-B	153 306	QSM-M5-6
	25	100 ... 160	151 692	MPYE-5-1/8-LF-010-B	153 002	QS-1/8-6
		225 ... 750	151 692	MPYE-5-1/8-LF-010-B	153 004	QS-1/8-8
		850 ... 2,000	151 693	MPYE-5-1/8-HF-010-B	153 004	QS-1/8-8
	32	100	151 692	MPYE-5-1/8-LF-010-B	153 002	QS-1/8-6
		160 ... 300	151 692	MPYE-5-1/8-LF-010-B	153 004	QS-1/8-8
		360 ... 1,750	151 693	MPYE-5-1/8-HF-010-B	153 004	QS-1/8-8
		2,000	151 694	MPYE-5-1/4-010-B	153 004	QS-1/8-8
	40	100 ... 225	151 692	MPYE-5-1/8-LF-010-B	153 005	QS-1/4-8
		300 ... 750	151 693	MPYE-5-1/8-HF-010-B	153 005	QS-1/4-8
		850 ... 1,000	151 693	MPYE-5-1/8-HF-010-B	153 007	QS-1/4-10
		1,250 ... 2,000	151 694	MPYE-5-1/4-010-B	153 007	QS-1/4-10
	63	100 ... 160	151 692	MPYE-5-1/8-LF-010-B	153 006	QS-3/8-8
		225 ... 300	151 693	MPYE-5-1/8-HF-010-B	153 006	QS-3/8-8
		360 ... 450	151 694	MPYE-5-1/4-010-B	153 008	QS-3/8-10
		500 ... 2,000	151 695	MPYE-5-3/8-010-B	153 009	QS-3/8-12

Linear drives DGPL, external displacement encoder

Features

Individual positioning components with linear drive DGPL ...

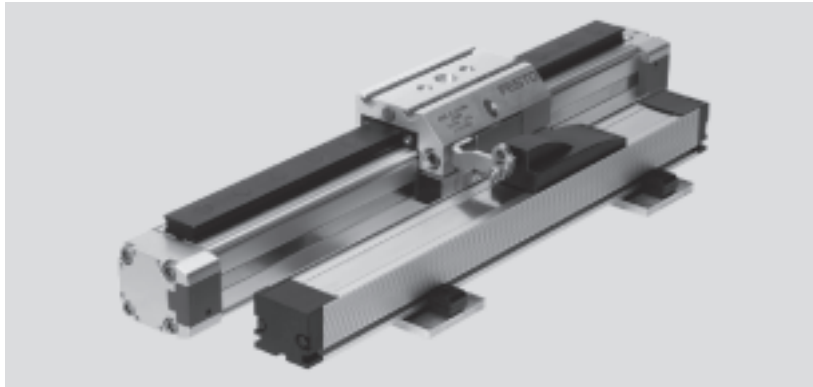

Proportional directional control valve
MPYE-...
→ Internet: mpye



Soft Stop → Internet: soft stop

End position controller
SPC11-POT-TLF



Positioning technology → Internet: spc

Axis interface
SPC-AIF-POT



Axis positioning controller
SPC200



Linear drives DGPL, external displacement encoder

Features

FESTO

DGPL, with recirculating ball bearing guide

- Piston \varnothing 25 ... 63 mm
- Stroke 225 ... 2,000 mm
- Standard slide or extended slide
- High characteristic load values
- Air connections on both sides



DGPL, with recirculating ball bearing guide and clamping unit

- Piston \varnothing 25...40 mm
- Stroke 225 ... 2,000 mm
- Standard slide or extended slide
- In the event of a loss of pressure, the slide can be fixed in vertical operation using the clamping unit.
- High characteristic load values
- Air connections on both sides



Linear drives DGPL, external displacement encoder

Peripherals overview

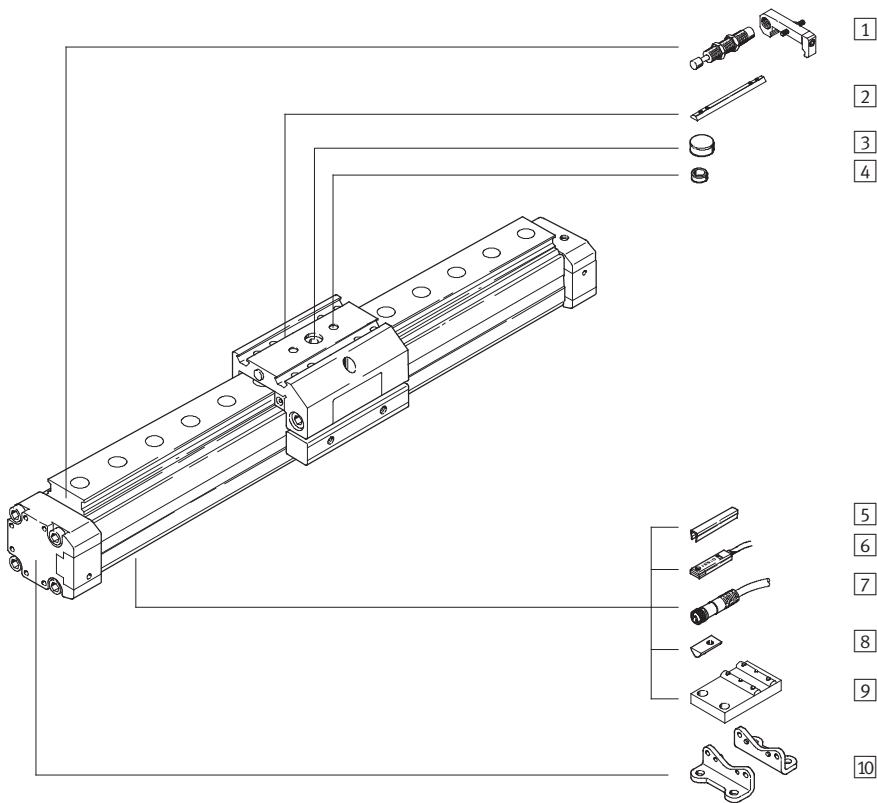

Displacement encoder attachment position 11

Slide at rear (SH)

Slide at front (SV)

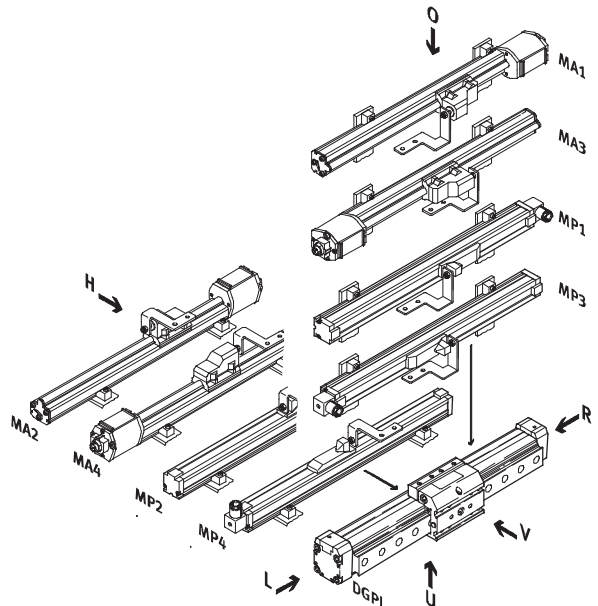
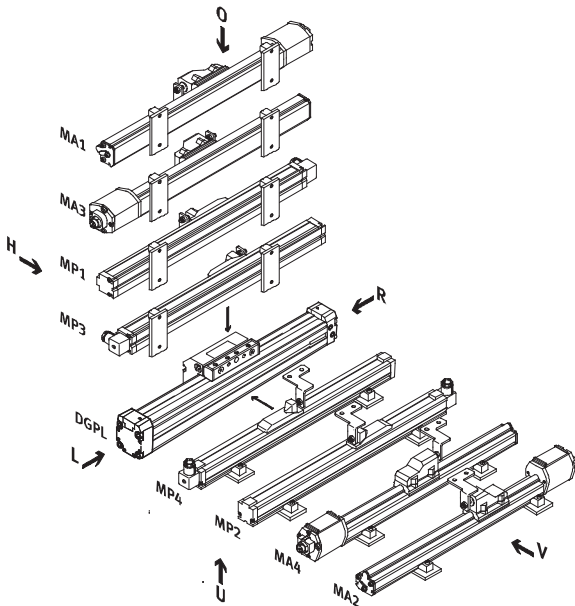

Linear drives DGPL, external displacement encoder

Peripherals overview

Variants and accessories		
Type	Brief description	→ Page/Internet
1 Shock absorber kits C	to avoid damage at the end stop, in the event of malfunctions	119
2 Slot nut for slide X	for mounting loads and attachments on the slide	120
3 Central mounting Q	for centring loads and attachments on the slide	120
4 Centring sleeves Z	for centring loads and attachments on the slide	120
5 Slot cover B/S	to protect against the ingress of dirt	120
6 Proximity sensors G/H/I/J/N	for additional sensing of the piston position, can be ordered optionally, only in conjunction with the order code A in the drive's modular product section.	122
7 Cable with socket V	for proximity sensor	122
8 Slot nut for mounting slot Y	for mounting attachments	120
9 Central support M	to mount the axis	117
10 Foot mounting F	to mount the axis	117
11 Displacement encoder attachment position MA1 ... MA4/MP1 ... MP4	for drive position measurement	83

Linear drives DGPL, external displacement encoder

Type codes

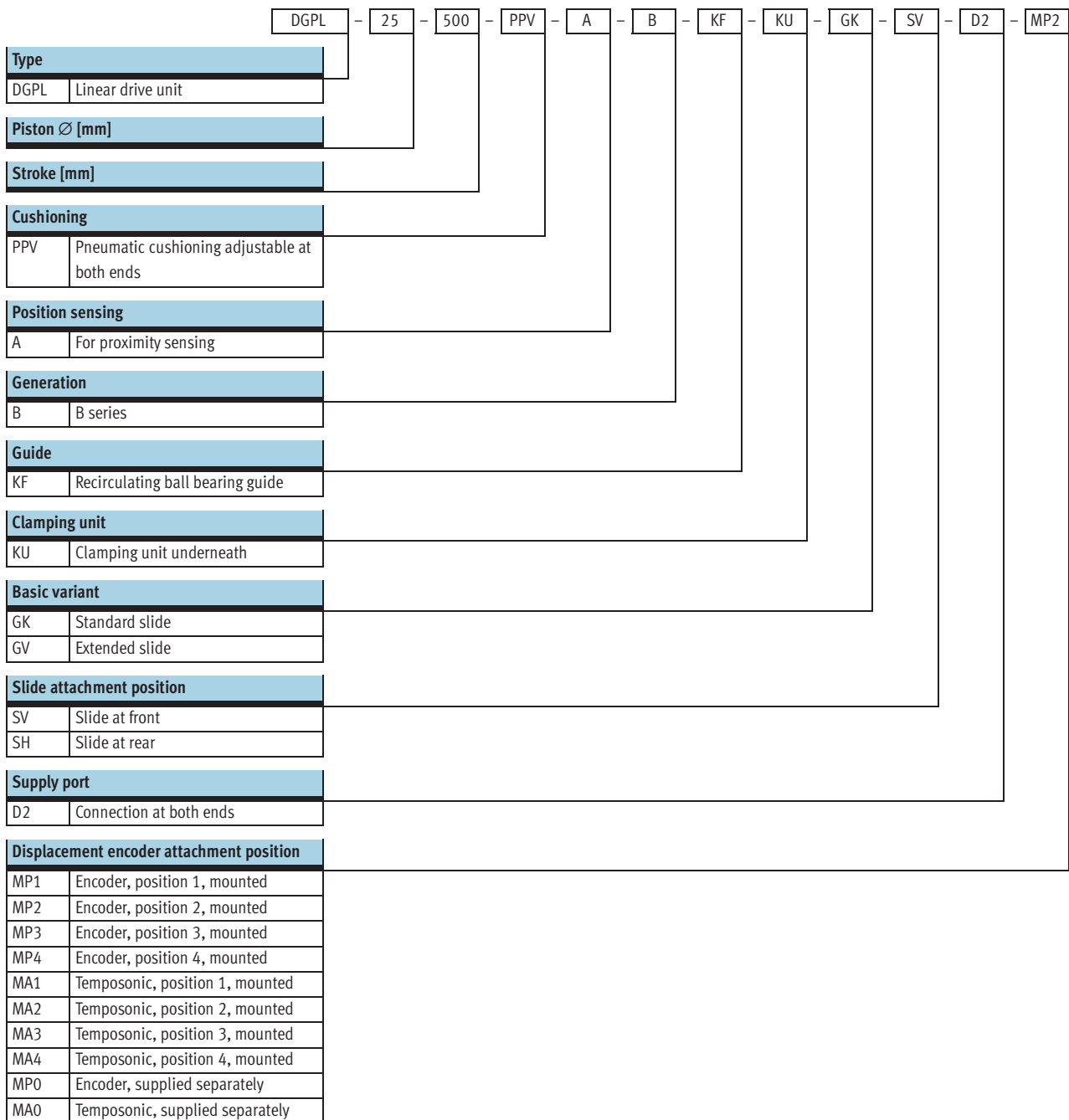

Linear drives DGPL, external displacement encoder

Type codes

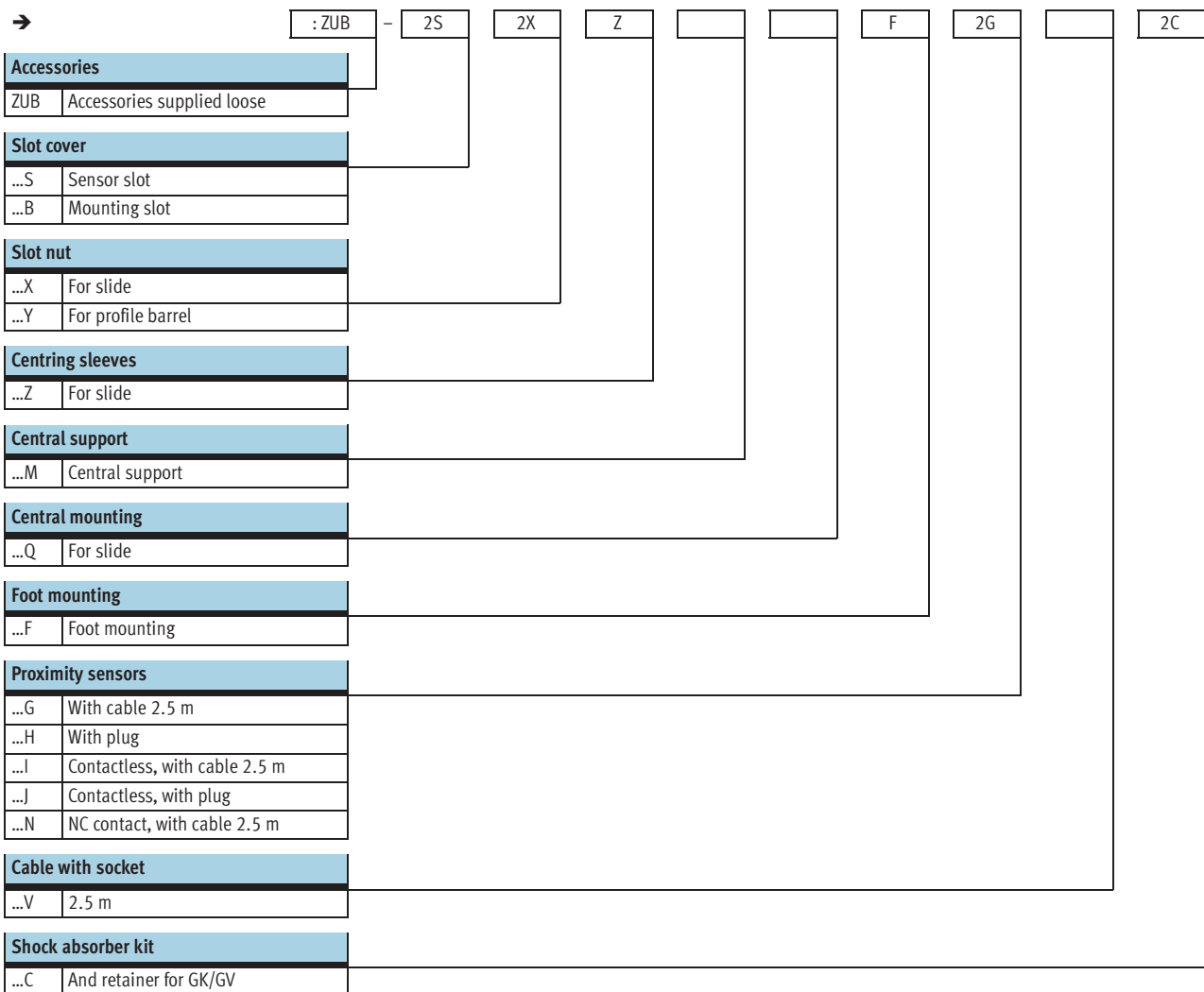

Linear drives DGPL, external displacement encoder

Technical data

Function



- N- Diameter
25 ... 63 mm
- T- Stroke length
225 ... 2,000 mm

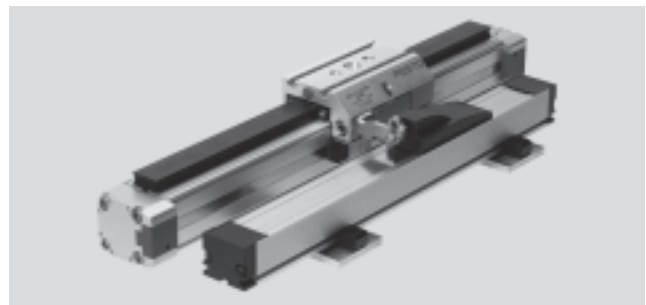

General technical data					
Piston Ø	25	32	40	50	63
Design	Piston Driver Profile barrel				
Mode of operation	Double-acting				
Operating medium ¹⁾	Compressed air, filtered and unlubricated, filter unit 5 µm				
Cushioning	Pneumatic cushioning adjustable at both ends				
Cushioning length [mm]	18	20	30		
Position sensing	Displacement encoder, attached externally For proximity sensing				
Measuring principle (displacement encoder)	➔ Internet: displacement encoders				
Type of mounting	Foot mounting				
Stroke ²⁾³⁾ [mm]	225, 300, 360, 450, 500, 600, 750, 1,000, 1,250, 1,500, 1,750, 2,000				
Protection against torsion/guide	Guide rail with slide Recirculating ball bearing				
Clamping unit	➔ Internet: dgpl				
Pneumatic connection	G1/8		G1/4		G3/8
Electrical connection	➔ Internet: displacement encoders				

- 1) The proportional directional control valve MPYE used requires the characteristic values.
- 2) Note stroke reduction in conjunction with SPC200.
- 3) Supply of compressed air to each end of the cylinder (feature D2) is absolutely essential for Soft Stop SPC11 and axis controller SPC200 as of a length of 500 mm.

Forces [N] and impact energy [Nm]					
Piston Ø	25	32	40	50	63
Theoretical force at 6 bar	295	483	754	1,178	1,870
Max. impact energy at the end positions ¹⁾	0.1	0.2	0.4	0.8	0.8

- 1) Cushioning PPV must be completely open for applications with Soft Stop SPC11 and axis controller SPC200.

Permissible impact velocity:

$$v_{perm.} = \sqrt{\frac{2 \times E_{perm.}}{m_{dead} + m_{load}}}$$

Maximum permissible load:

$$m_{load} = \frac{2 \times E_{perm.}}{v^2} - m_{dead}$$

v_{perm.} Permissible impact velocity
 E_{perm.} Max. impact energy
 m_{dead} Moving load (drive)
 m_{load} Moving work load

Note
 These specifications represent the maximum values which can be reached. Note the maximum permitted impact energy.

Linear drives DGPL, external displacement encoder

Technical data

Positioning characteristics with axis controller SPC200					
Piston Ø	25	32	40	50	63
Repetition accuracy [mm]	→ 77				
Mounting position	Any				
Minimum load, horizontal ¹⁾ [kg]	2	3	5	8	12
Maximum load, horizontal ¹⁾ [kg]	30	45	75	120	180
Minimum load, vertical ¹⁾ [kg]	2	3	5	8	12
Maximum load, vertical ¹⁾ [kg]	10	15	25	40	60
Min. speed of travel [m/s]	0.05				
Max. speed of travel [m/s]	3				
Typ. positioning time, long stroke ²⁾ [s]	0.80/1.20	0.90/1.25	0.80/1.20	1.00/1.25	0.95/1.25
Typ. positioning time, short stroke ³⁾ [s]	0.50/0.70	0.50/0.65	0.45/0.65	0.55/0.65	0.55/0.65
Minimum positioning stroke ⁴⁾ [%]	3				
Stroke reduction ⁵⁾ [mm]	25		35		
Recommended proportional directional control valve	→ 121				

- 1) Load = effective load + mass of all moving parts on the drive
- 2) At 6 bar, horizontal mounting position, DGPL-XX-1250, 1000 mm positioning travel at min./max. load
- 3) At 6 bar, horizontal mounting position, DNCM-XX-1250, 100 mm positioning travel at min./max. load
- 4) In relation to the maximum stroke of the drive, but never more than 20 mm.
- 5) The stroke reserve is to be maintained on every side of the drive, the max. positionable stroke is therefore: Stroke – 2x stroke reserve

Positioning characteristics with end position controller SPC11					
Piston Ø	25	32	40	50	63
Repetition accuracy of a mid-position ¹⁾ [mm]	±2				
Mounting position	Any				
Minimum load, horizontal ²⁾ [kg]	2	3	5	8	12
Maximum load, horizontal ²⁾ [kg]	30	45	75	120	180
Minimum load, vertical ²⁾ [kg]	2	3	5	8	12
Maximum load, vertical ²⁾ [kg]	10	15	25	40	60
Travel time [s]	→ Sizing software "Smartb Soft Stop": → www.festo.com				
Recommended proportional directional control valve	→ 121				

- 1) In the stroke range from 225 ... 2,000 mm
- 2) Load = effective load + mass of all moving parts on the drive

Operating and environmental conditions					
Piston Ø	25	32	40	50	63
Operating pressure ¹⁾ [bar]	4 ... 8				
Ambient temperature ²⁾ [°C]	-10 ... +60				
Vibration resistance	To DIN/IEC 68 Parts 2 -6, severity level 2				
Continuous shock resistance	To DIN/IEC 68 Parts 2 -27, severity level 2				
CE symbol	To 89/336/EEC (EMC regulation)				
Protection class (displacement encoder)	→ Internet: displacement encoder				

- 1) Only applies for applications with Soft Stop SPC11 and axis controller SPC200.
- 2) Note operating range of proximity sensors.

Linear drives DGPL, external displacement encoder

Technical data

Weights [g] without displacement encoder						
Piston \varnothing	25	32	40	50	63	
Basic weight	1,520	2,720	4,480	9,600	15,370	
Additional weight per 10 mm stroke	53	69	97	167	236	
Clamping unit	714	1,100	1,694	–	–	
Additional weight of clamping unit per 10 mm stroke	27	34	42	–	–	
Moving load	Standard slide GK	605	895	1,700	3,000	4,990
	Extended slide GV	950	1,375	2,603	4,700	7,860
	Clamping unit	185	250	461	–	–

Note

Electrical data, displacement encoder:	Analogue displacement encoder (Order code: MP) → Internet: displacement encoder	Digital displacement encoder (Order code: MA) → Internet: displacement encoder
--	---	--

Materials

Sectional view

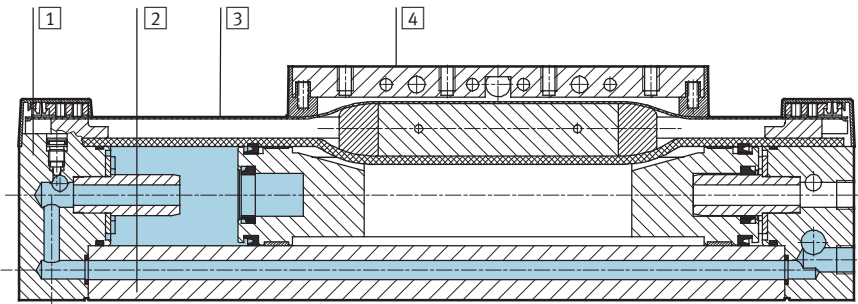

Displacement encoder materials
→ Internet: displacement encoder

Drive	
1 End cap	Anodised aluminium
2 Profile	Anodised aluminium
3 Cover strip	Steel, corrosion resistant
4 Driver	Anodised aluminium
– Slide	Anodised aluminium
– Guide rail	Corrosion resistant steel
– Seals	Nitrile rubber, polyurethane

Repetition accuracy

Tolerance t [mm] as a function of the stroke l [mm]

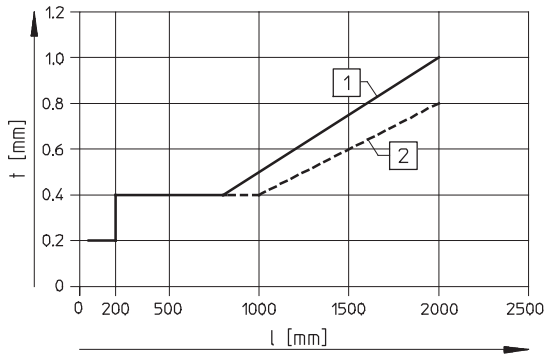
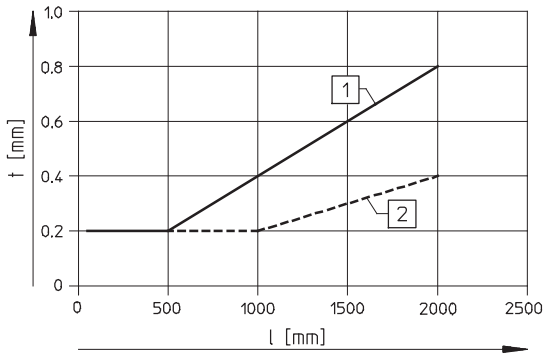

- 1 with analogue displacement encoder
- 2 with digital displacement encoder

Linear drives DGPL, external displacement encoder

Technical data



Characteristic load values

The forces and torques specified refer to the centre line of the profile barrel internal diameter.

They must not be exceeded during dynamic operation. Special attention must be paid to the cushioning phase.

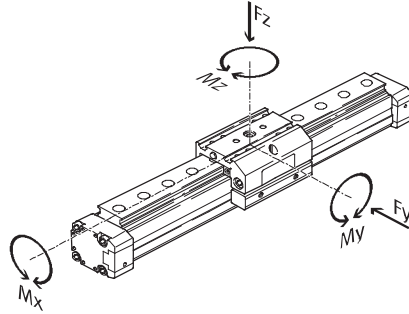

If the drive is subjected to more than two of the indicated forces and torques simultaneously, the following equations must be satisfied in addition to the indicated maximum loads.

$$0,4 \times \frac{F_z}{F_{z_{max}}} + \frac{M_x}{M_{x_{max}}} + \frac{M_y}{M_{y_{max}}} + 0,2 \times \frac{M_z}{M_{z_{max}}} \leq 1$$

$$\frac{F_z}{F_{z_{max}}} \leq 1 \quad \frac{M_z}{M_{z_{max}}} \leq 1$$

Permissible forces and torques

Piston Ø	25		32		40		50		63	
	GK	GV	GK	GV	GK	GV	GK	GV	GK	GV
F _y _{max.} [N]	3,080	3,080	3,080	3,080	7,300	7,300	7,300	7,300	14,050	14,050
F _z _{max.} [N]	3,080	3,080	3,080	3,080	7,300	7,300	7,300	7,300	14,050	14,050
M _x _{max.} [Nm]	45	45	63	63	170	170	240	240	580	580
M _y _{max.} [Nm]	85	170	127	250	330	660	460	920	910	1,820
M _z _{max.} [Nm]	85	170	127	250	330	660	460	920	910	1,820

Maximum permissible support span l as a function of the force F

The axis may need to be supported with central supports MUP in order to

limit deflection in the case of large strokes. The following diagrams serve

to determine the maximum permissible support span l as a

function of the force F.

Force on the surface of the slide

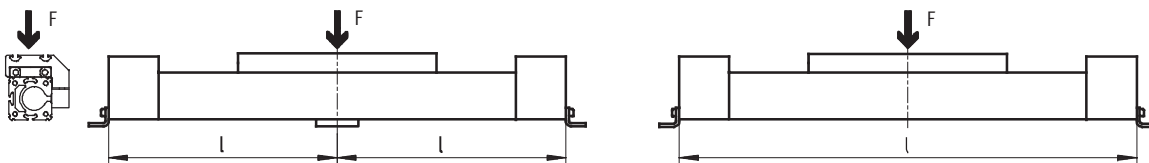

Maximum support span l (without central support) as a function of the force F

Piston Ø 25 ... 40

Piston Ø 50/63

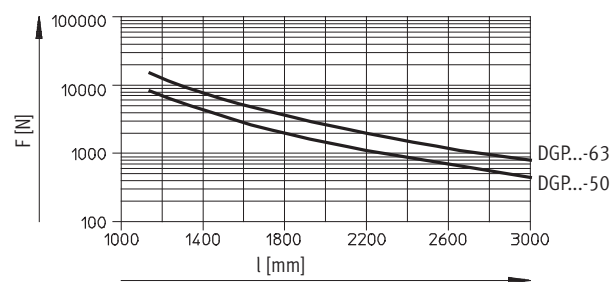
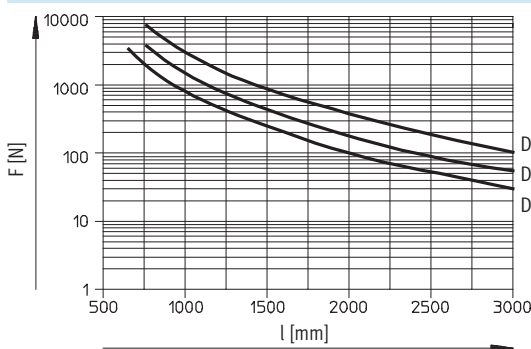

Linear drives DGPL, external displacement encoder

Technical data

Dimensions

Download CAD Data → www.festo.com/us/cad

Standard slide GK

Piston Ø 25

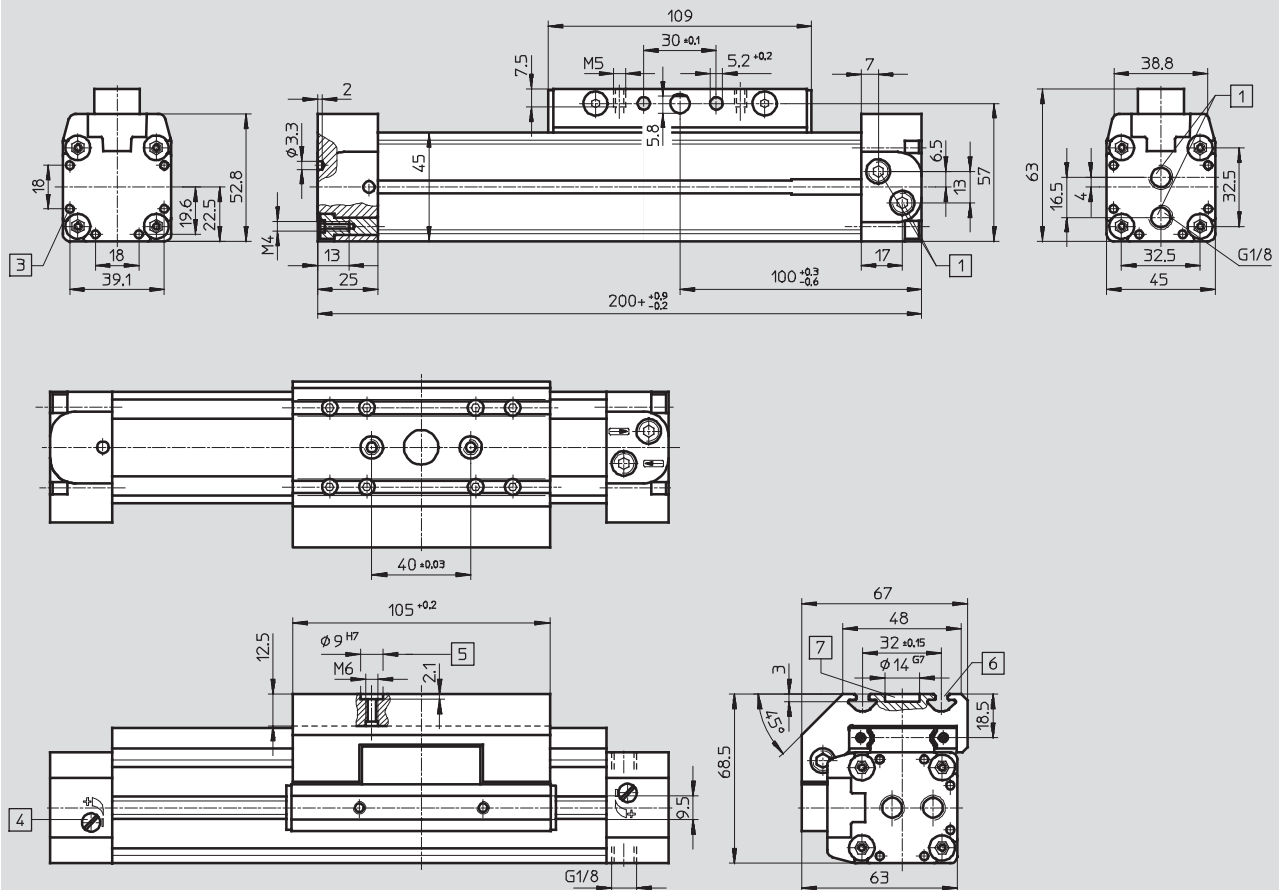

- | | | | |
|---|---|---|------------------------|
| <p>1 Supply ports at one end, option of three sides of an end cap (D2 variant: supply port at both ends, option of three sides per end cap)</p> | <p>3 Mounting hole for foot mounting HP</p> | <p>6 Mounting slot for slot nut NSTL</p> | + = plus stroke length |
| <p>4 Regulating screw for adjustable end-position cushioning</p> | <p>5 Hole for centring sleeve ZBH-9</p> | <p>7 Drilled hole for central mounting SLZZ</p> | |

Linear drives DGPL, external displacement encoder

Technical data

Extended slide GV

Piston $\varnothing 25$

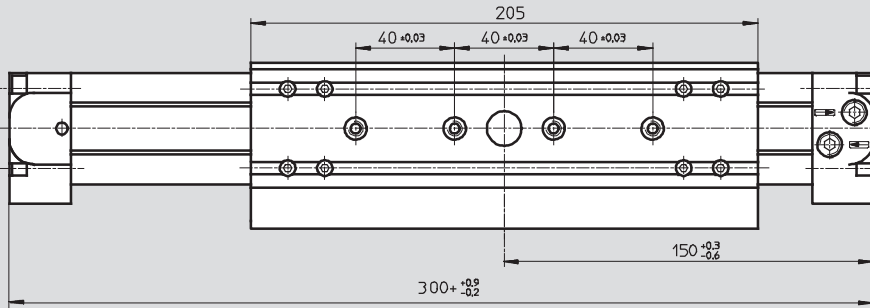

+ = plus stroke length

Profile barrel

Piston $\varnothing 25$

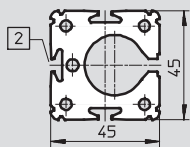

2 Sensor slot for proximity sensor

Linear drives DGPL, external displacement encoder

Technical data

FESTO

Dimensions

Download CAD Data → www.festo.com/us/cad

Standard slide GK

Piston Ø 32 ... 63

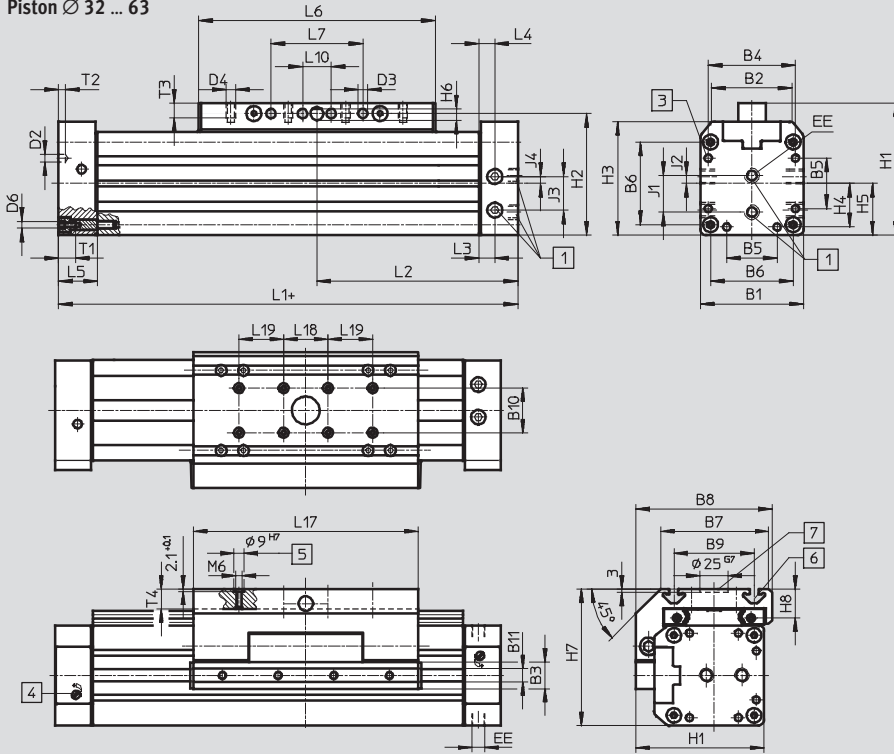

- 1 Supply ports at one end, option of three sides of an end cap (D2 variant: supply port at both ends, option of three sides per end cap)
 - 3 Mounting hole for foot mounting HP
 - 4 Regulating screw for adjustable end-position cushioning
 - 5 Hole for centring sleeve ZBH-9
 - 6 Mounting slot for slot nut NSTL
 - 7 Drilled hole for central mounting SLZZ
- + = plus stroke length

Extended slide GV

Piston Ø 32 ... 63

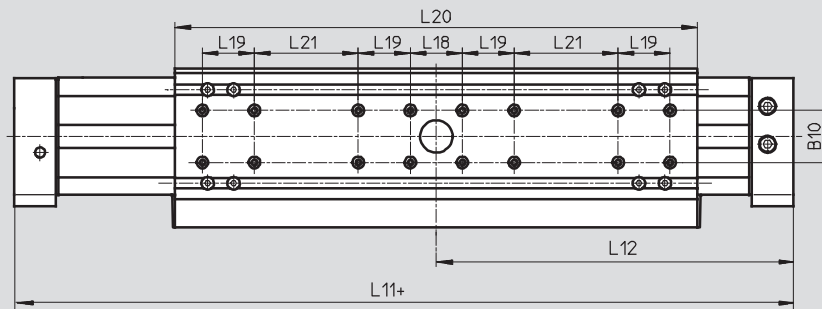

Profile barrel

Piston Ø 32

Piston Ø 40

Piston Ø 50

Piston Ø 63

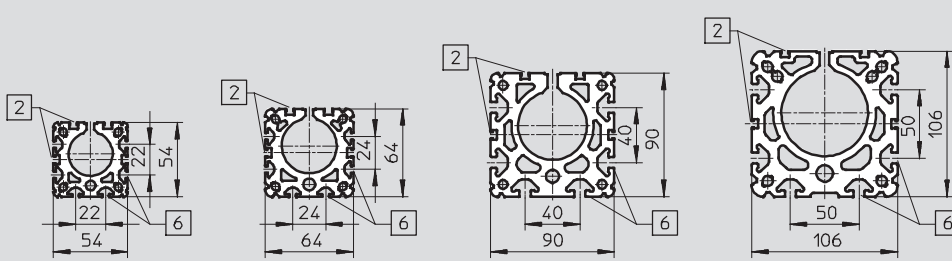

- 2 Sensor slot for proximity sensor
- 6 Mounting slot for slot nut NST

Linear drives DGPL, external displacement encoder

FESTO

Technical data

∅ [mm]	B1	B2	B3 +0.2	B4	B5	B6	B7	B8	B9	B10 ±0.03	B11	D2 ∅
32	54	35.8	19	46	21	40	63	79	47 ±0.15	20	9.5	4.3
40	64	45.7	21	53	28	49	78.5	96.5	55 ±0.2			
50	90	69.2	24	76	44	72	97	122	72 ±0.2	40	12	6.3
63	106	84.8		89		83	121	142	90 ±0.25			

∅ [mm]	D3 ∅ +0.2	D4	D6	EE	H1	H2	H3	H4	H5	H6	H7	H8
32	5.2	M5	M5	G1/8	72	66	62	23	27	5.8	77.5	18.5
40	6.5	M6		G1/4	86	78	71.8	26.5	32	7.7	90.5	20
50	8.5	M8	M6	G3/8	115	106	99	36	45	9.7	122.5	26
63			M8		131	122	115	44.5	53		144.5	30

∅ [mm]	J1	J2	J3	J4	L1	L2	L3	L4	L5	L6	L7	L10 ±0.15
32	19	4.2	14	4.7	250	125	17	8.5	31	135	50 ±0.1	-
40	22	5	21	9.1	300	150	11.5	11.5		171	70 ±0.1	
50	31.8	6.8	29.3	6	350	175	14	14	34	206	80 ±0.1	
63	36	8	31	14	400	200		234		110 ±0.1		

∅ [mm]	L11 +0.9/-0.2	L12 +0.3/-0.6	L17	L18 ±0.03	L19 ±0.03	L20	L21 ±0.1	T1	T2	T3	T4 max.
32	380	190	131 ±0.2	40	-	261	40	13.2	3	7.5	12.5
40	470	235	167 ±0.2		40	337			4	10.5	
50	550	275	202 ±0.2		402	80	15.2	6	12.5	18.5	
63	650	325	230 ±0.2		480	120	21.2			20.5	

Note

Accessories → 117

Linear drives DGPL, external displacement encoder

Ordering data – Modular product system

Order code

Mandatory data/Options

- KU Clamping unit underneath
- GK Standard slide
- GV Extended slide
- SV Slide at rear
- SH Slide at front
- D2 Air connection at both ends

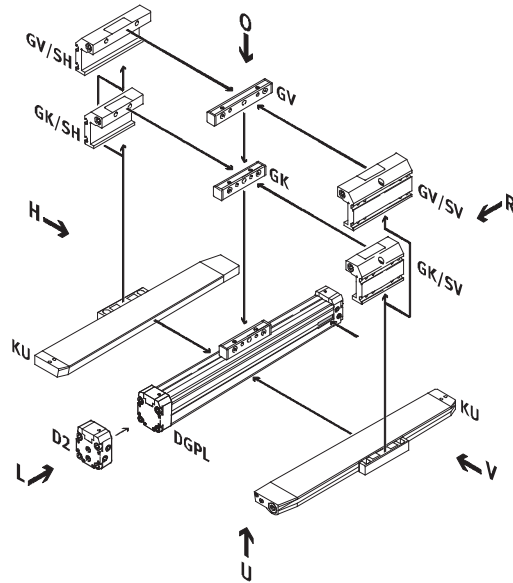

Attachment position for slides at rear (SH)

Attachment position for slides at front (SV)

- MP Analogue displacement encoder
- MA Digital displacement encoder

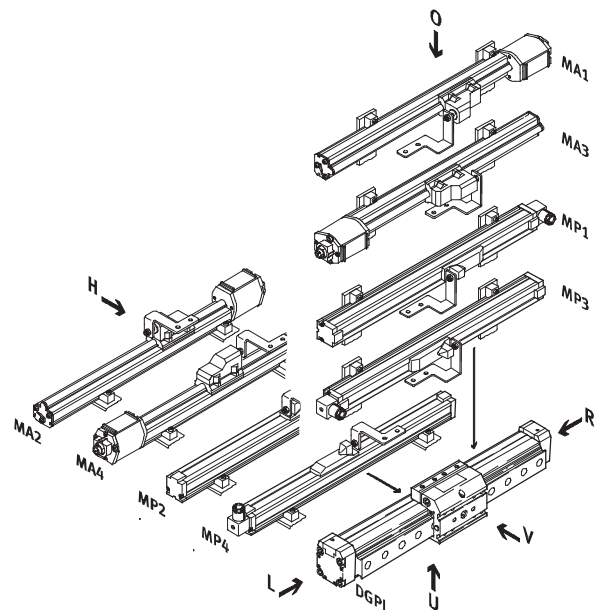
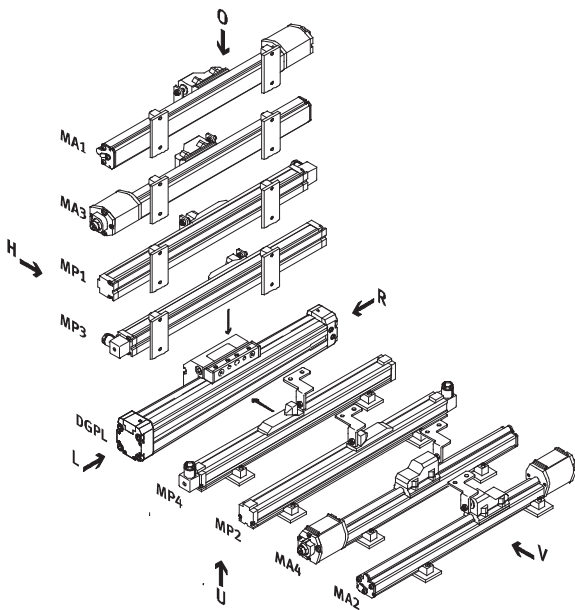

Note

- O top
- U underneath
- R right
- L left
- V front
- H rear

Linear drives DGPL, external displacement encoder

Ordering data – Modular product system



Order code

Options

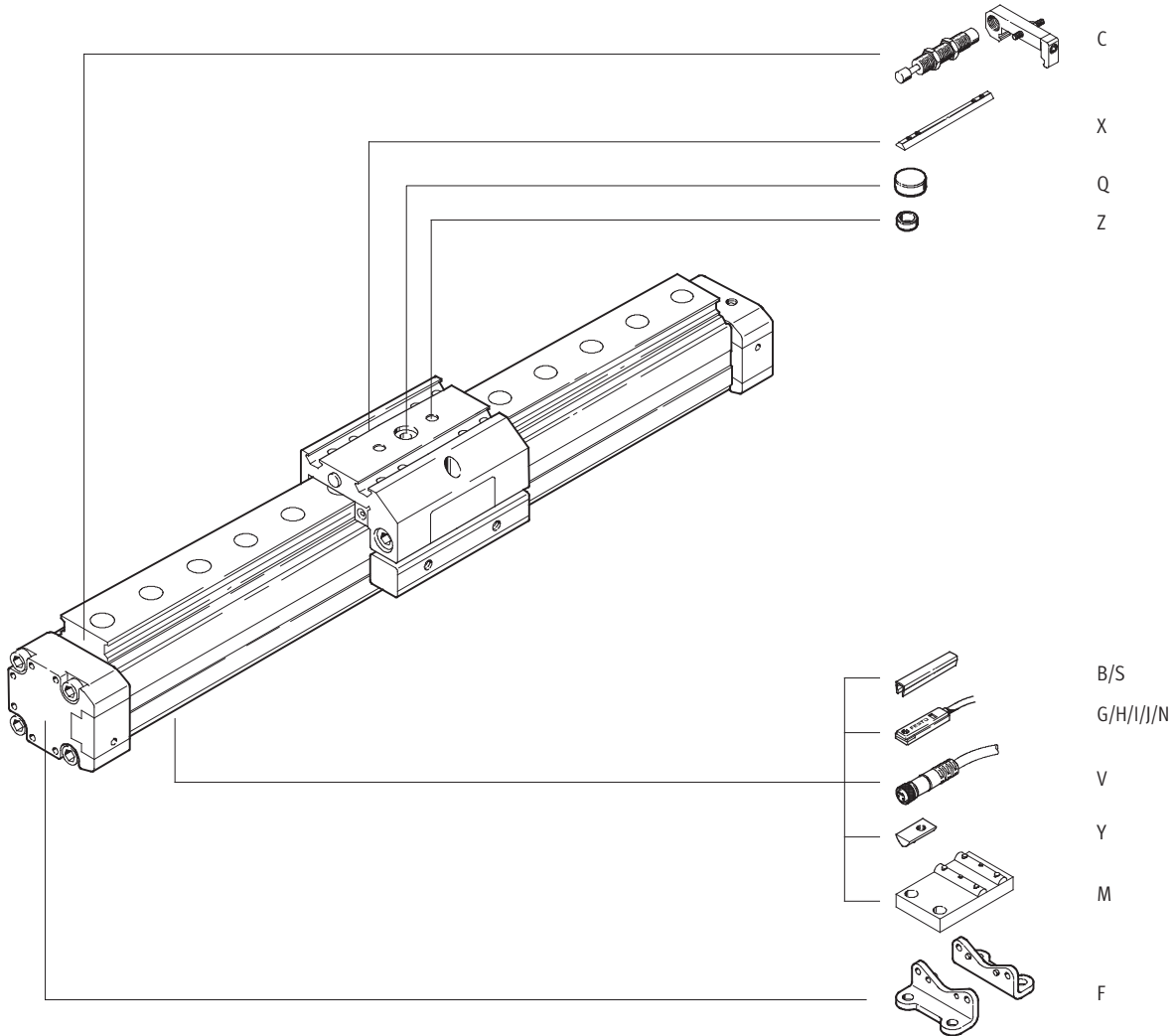

Linear drives DGPL, external displacement encoder

Ordering data – Modular product system

M Mandatory data								O Options →				
Module No.	Drive function	Size	Stroke	Cushioning	Position sensing	Generation	Guide	Clamping unit	Basic variant	Slide attachment position	Supply port	Displacement encoder
175 134	DGPL	25	225 ...	PPV	A	B	KF	KU	GK	SV	D2	MP1
175 135		32	2 000						GV	SH		MP2
175 136		40										MP3
175 137		50										MP4
175 138		63										MA1
Ordering example												
175 136	DGPL	- 40	- 750	- PPV	- A	- B	- KF	-	- GV	- SH	- D2	- MA2

Ordering table										
Size	25	32	40	50	63	Conditions	Code	Enter code		
M	Module No.	175 134	175 135	175 136	175 137	175 138				
	Drive function	Pneumatic linear drive with slide						DGPL		DGPL
	Size	25	32	40	50	63		-...		
	Stroke [mm]	225, 300, 360, 450, 500, 600, 750, 1 000, 1 250, 1 500, 1 750, 2 000						-...		
	Cushioning	Pneumatic cushioning adjustable at both ends						-PPV		-PPV
	Position sensing	For proximity sensing						-A		-A
	Generation	B series						-B		-B
	Guide	Recirculating ball bearing guide						-KF		-KF
O	Clamping unit	Underneath		-	-				-KU	
	Basic variant	Standard piston/slide					1	-GK		
		Extended piston/slide						-GV		
	Slide attachment position	Slide at front					2	-SV		
		Slide at rear						-SH		
	Supply port	at both ends						-D2		
	Displacement encoder	Encoder, position 1, mounted						-MP1		
		Encoder, position 2, mounted					3	-MP2		
		Encoder, position 3, mounted						-MP3		
		Encoder, position 4, mounted					3	-MP4		
		Temposonic with CAN axis interface, position 1, mounted						-MA1		
		Temposonic with CAN axis interface, position 2, mounted					3	-MA2		
		Temposonic with CAN axis interface, position 3, mounted						-MA3		
		Temposonic with CAN axis interface, position 4, mounted					3	-MA4		
		Encoder, supplied separately						-MPO		
		Temposonic with CAN axis interface, supplied separately						-MA0		

- 1 GK or GV Must be selected
- 2 SV or SH Must be selected
- 3 MP2, MP4, MA2, MA4 Not with clamping unit KU

Transfer order code

Linear drives DGPL, external displacement encoder

Ordering data – Modular product system

Options										
Accessories	Slot cover	Slot nut	Centring sleeve	Central support	Central mounting	Foot mounting	Proximity sensor, magnetic	Plug socket	Shock absorber kit	
ZUB	...S ...B	...X ...Y	...Z	...M	...Q	...F	...G ...H ...I ...J ...N	...V	...C	
: ZUB	- 2S2B	2XY	Z		Q	F			2C	

Ordering table												
Size	25	32	40	50	63	Conditions	Code	Enter code				
Accessories	Supplied separately							:ZUB-	:ZUB-			
Slot cover, x2, 0.5 m	Sensor slot	1 ... 10							...S			
	Mounting slot	-							...B			
Slot nut	Slide	1 ... 10							...X			
	Mounting slot	-							...Y			
Centring sleeve (pack of 10)	10, 20, 30, 40, 50, 60, 70, 80, 90							...Z				
Central support	1 ... 10							...M				
Central mounting	1 ... 10							...Q				
Foot mounting	1 ... 10							...F				
Magnetic proximity sensor	With cable 2.5 m	1 ... 10							...G			
	With plug	1 ... 10							...H			
Magnetic proximity sensor, contactless	With cable 2.5 m	1 ... 10							...I			
	With plug	1 ... 10							...J			
Magnetic proximity sensor	NC contact, with cable 2.5 m	1 ... 10							...N			
Cable with socket, 2.5 m	1 ... 10							...V				
Shock absorber kit	1 ... 10							...C				

Transfer order code

: ZUB -

Linear drives DGPI/DGPIL, integrated displacement encoder

Features

Individual positioning components with linear drive DGPI/DGPIL ...

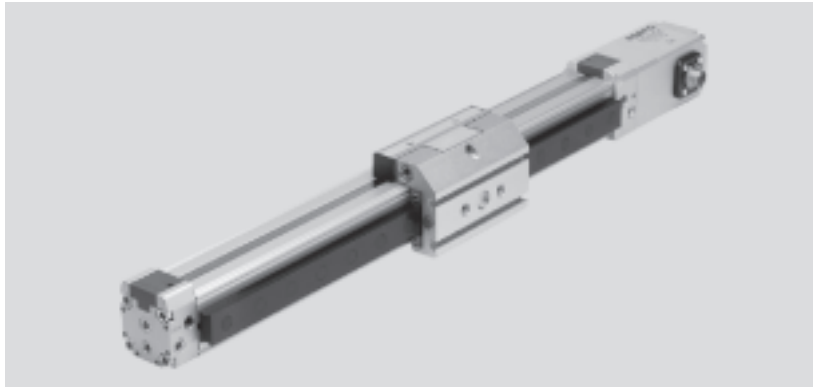

Proportional directional control valve
MPYE-...
→ Internet: mpye



Soft Stop → Internet: soft stop

End position controller
SPC11-MTS-AIF



Positioning technology → Internet: spc

Axis interface
SPC-AIF-MTS



Axis positioning controller
SPC200



Linear drives DGPI/DGPIL, integrated displacement encoder

FESTO

Features

DGPI, without guide

89

- Piston \varnothing 25 ... 63 mm
- Stroke 225 ... 2,000 mm
- Standard driver
- Low characteristic load values
- Air connections on both sides



DGPIL, with recirculating ball bearing guide

103

- Piston \varnothing 25 ... 63 mm
- Stroke 225 ... 2,000 mm
- Standard slide
- High characteristic load values
- Air connections on both sides



DGPIL, with recirculating ball bearing guide and protected version

103

- Piston \varnothing 25...40 mm
- Stroke 225 ... 2,000 mm
- Protected from above and the sides against the ingress of particles
- High characteristic load values
- Air connections on both sides



Linear drives DGPI, integrated displacement encoder

Peripherals overview

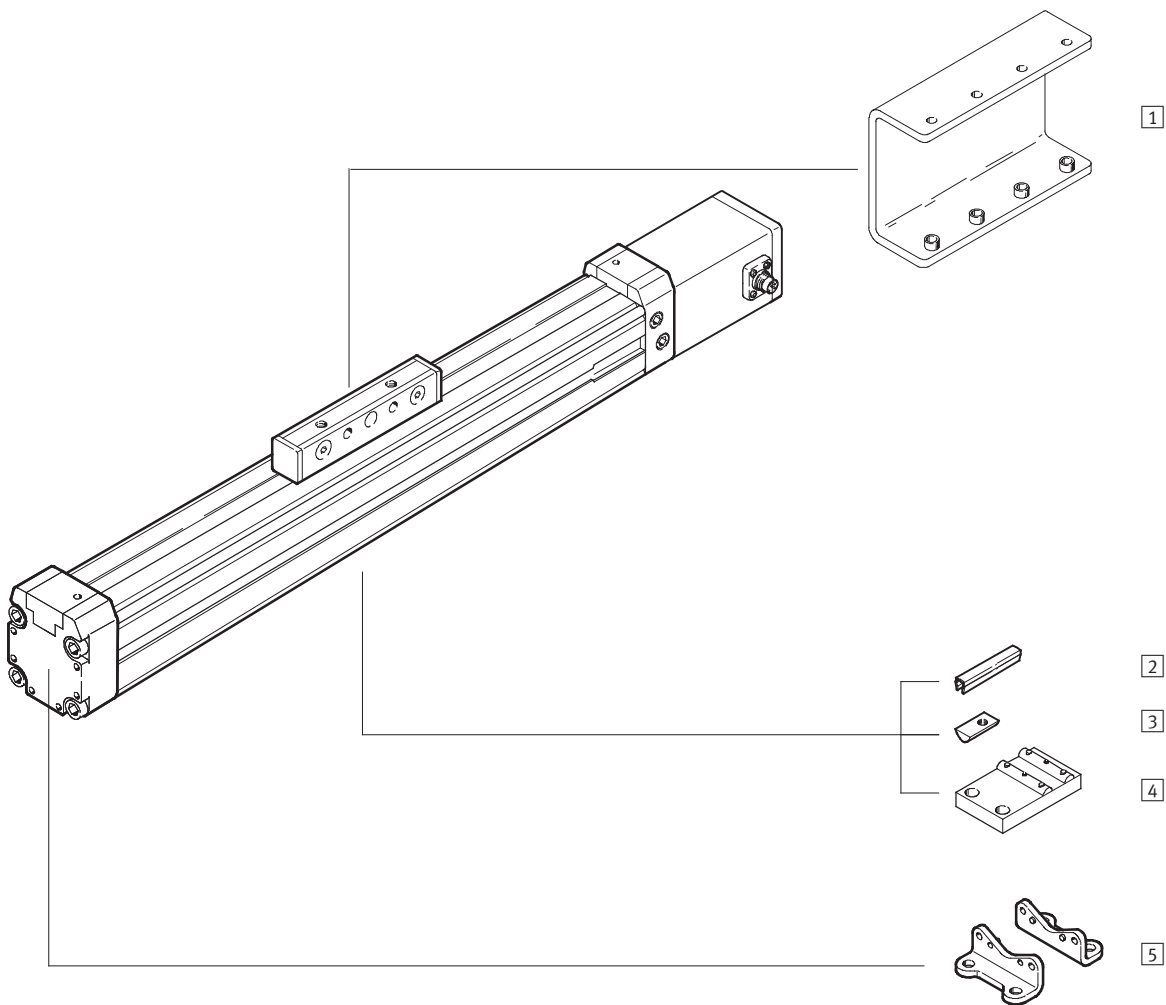

Variants and accessories		
Type	Brief description	→ Page/Internet
1 Load inverter AK	to secure the load from beneath, is supplied attached	118
2 Slot cover B/S	to protect against the ingress of dirt	120
3 Slot nut Y	for mounting attachments	120
4 Central support M	to mount the axis	117
5 Foot mounting F	to mount the axis	117

Linear drives DGPI, integrated displacement encoder

Type codes

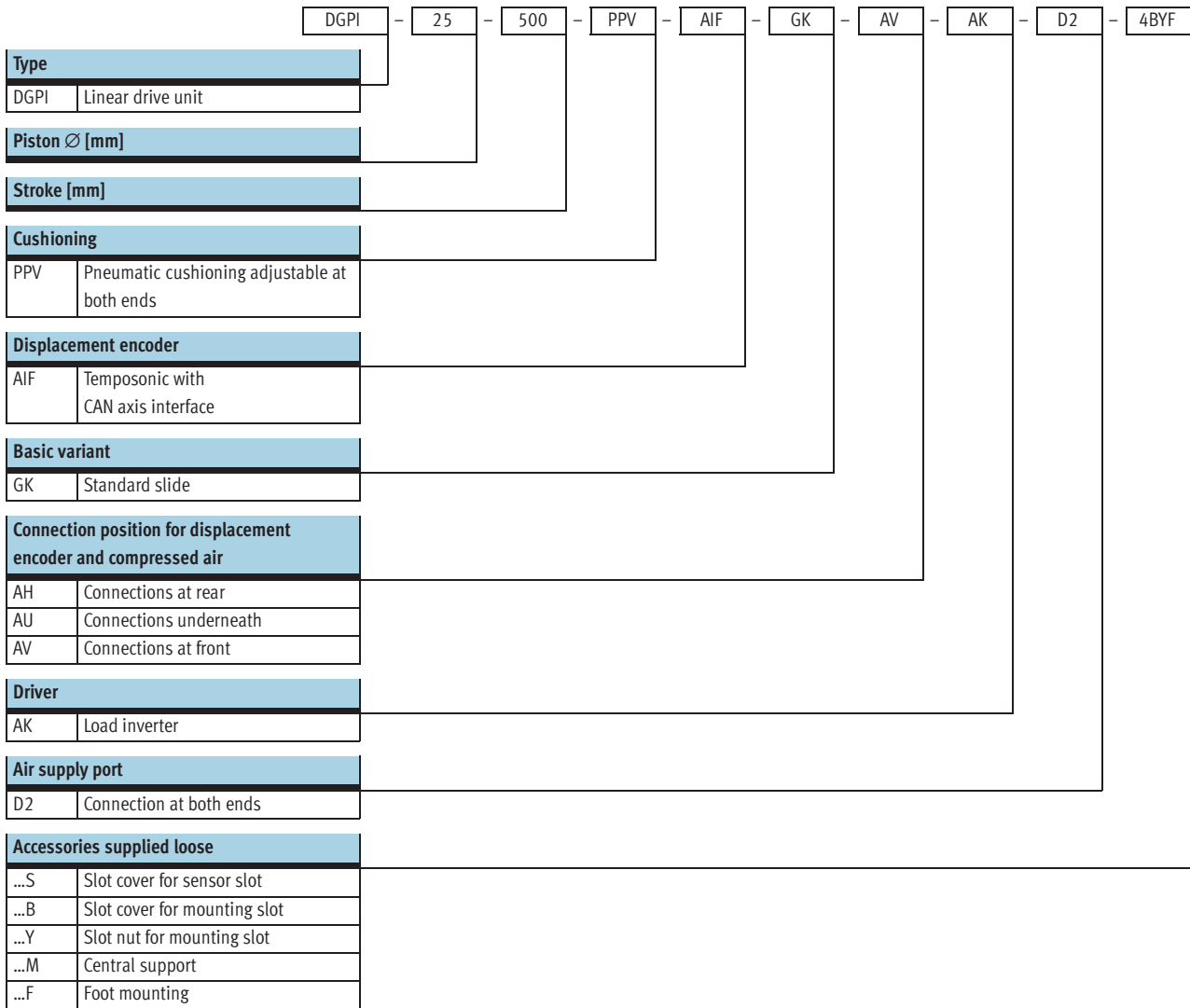

Linear drives DGPI, integrated displacement encoder

Technical data

Function

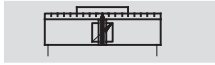

- N- Diameter
25 ... 63 mm
- T- Stroke length
225 ... 2,000 mm



General technical data					
Piston Ø	25	32	40	50	63
Design	Piston				
	Driver				
	Profile barrel				
Mode of operation	Double-acting				
Operating medium ¹⁾	Compressed air, filtered and unlubricated, filter unit 5 µm				
Cushioning	Pneumatic cushioning adjustable at both ends				
Cushioning length [mm]	18	20	30		
Position sensing	Integrated displacement encoder				
Measuring principle	Digital, magnetostrictive, non-contacting, absolute measurement				
Type of mounting	Foot mounting				
Stroke ²⁾³⁾ [mm]	225, 300, 360, 450, 500, 600, 750, 1,000, 1,250, 1,500, 1,750, 2,000				
Pneumatic connection	G1/8		G1/4		G3/8
Electrical connection	6-pin round plug to DIN 45 322				

- 1) The proportional directional control valve MPYE used requires the characteristic values.
- 2) Note stroke reduction in conjunction with SPC200.
- 3) Supply of compressed air to each end of the cylinder (feature D2) is absolutely essential for Soft Stop SPC11 and axis controller SPC200 as of a length of 500 mm.

Forces [N] and impact energy [Nm]					
Piston Ø	25	32	40	50	63
Theoretical force at 6 bar	295	483	754	1,178	1,870
Max. impact energy at the end positions ¹⁾	0.1	0.2	0.4	0.8	0.8

- 1) Cushioning PPV must be completely open for applications with Soft Stop SPC11 and axis controller SPC200.

Permissible impact velocity:

$$v_{perm.} = \sqrt{\frac{2 \times E_{perm.}}{m_{dead} + m_{load}}}$$

- $v_{perm.}$ Permissible impact velocity
- $E_{perm.}$ Max. impact energy
- m_{dead} Moving load (drive)
- m_{load} Moving work load

Maximum permissible load:

$$m_{load} = \frac{2 \times E_{perm.}}{v^2} - m_{dead}$$

Note

These specifications represent the maximum values which can be reached. Note the maximum permitted impact energy.

Linear drives DGPI, integrated displacement encoder

FESTO

Technical data

Positioning characteristics with axis controller SPC200					
Piston \varnothing	25	32	40	50	63
Repetition accuracy [mm]	→ 77				
Mounting position	Any				
Minimum load, horizontal ¹⁾ [kg]	2	3	5	8	12
Maximum load, horizontal ¹⁾ [kg]	30	45	75	120	180
Minimum load, vertical ¹⁾ [kg]	2	3	5	8	12
Maximum load, vertical ¹⁾ [kg]	10	15	25	40	60
Min. speed of travel [m/s]	0.05				
Max. speed of travel [m/s]	3				
Typ. positioning time, long stroke ²⁾ [s]	0.75/1.20	0.85/1.20	0.75/1.20	0.95/1.25	0.90/1.20
Typ. positioning time, short stroke ³⁾ [s]	0.40/0.60	0.45/0.60	0.40/0.60	0.50/0.65	0.50/0.65
Minimum positioning stroke ⁴⁾ [%]	3				
Stroke reduction ⁵⁾ [mm]	25		35		
Recommended proportional directional control valve	→ 121				

- 1) Load = effective load + mass of all moving parts on the drive
- 2) At 6 bar, horizontal mounting position, DGPI-XX-1250, 1000 mm positioning travel at min./max. load
- 3) At 6 bar, horizontal mounting position, DNCM-XX-1250, 100 mm positioning travel at min./max. load
- 4) In relation to the maximum stroke of the drive, but never more than 20 mm.
- 5) The stroke reserve is to be maintained on every side of the drive, the max. positionable stroke is therefore: Stroke – 2x stroke reserve

Positioning characteristics with end position controller SPC11					
Piston \varnothing	25	32	40	50	63
Repetition accuracy of a mid-position ¹⁾ [mm]	±2				
Mounting position	Any				
Minimum load, horizontal ²⁾ [kg]	2	3	5	8	12
Maximum load, horizontal ²⁾ [kg]	30	45	75	120	180
Minimum load, vertical ²⁾ [kg]	2	3	5	8	12
Maximum load, vertical ²⁾ [kg]	10	15	25	40	60
Travel time [s]	→ Sizing software "Smart Soft Stop": → www.festo.com				
Recommended proportional directional control valve	→ 121				

- 1) In the stroke range from 225 ... 2,000 mm
- 2) Load = effective load + mass of all moving parts on the drive

Operating and environmental conditions					
Piston \varnothing	25	32	40	50	63
Operating pressure ¹⁾ [bar]	4 ... 8				
Ambient temperature [°C]	-10 ... +60				
Vibration resistance	To DIN/IEC 68 Parts 2 -6, severity level 1				
Continuous shock resistance	To DIN/IEC 68 Parts 2 -27, severity level 1				
CE marking symbol (see conformity declaration)	As per EU EMC directive				
Protection class (displacement encoder)	IP65 to IEC 60 529				
Corrosion resistance class CRC ²⁾	1				

- 1) Only applies for applications with Soft Stop SPC11 and axis controller SPC200.
- 2) Corrosion resistance class 1 according to Festo standard 940 070
Components requiring low corrosion resistance. Transport and storage protection. Parts that do not have primarily decorative surface requirements, e.g. in internal areas that are not visible or behind covers.

Weights [g]					
Piston \varnothing	25	32	40	50	63
Basic weight	1,540	2,150	3,500	6,980	10,600
Additional weight per 10 mm stroke	38	43	59	130	168
Moving load	180	314	551	1,045	1,775

Linear drives DGPI, integrated displacement encoder

Technical data

Electrical data, displacement encoder		
Power supply	[V DC]	24 (-15/+25%)
Max. current consumption	[mA]	90
Resolution	[mm]	≤ 0.01
Independent linearity ¹⁾	maximum [%]	0.02
Temperature coefficient	[ppm/°K]	≤ 15
Interface		Digital, CAN with protocol: SPC-AIF

1) Minimum ±50 µm

Materials

Sectional view

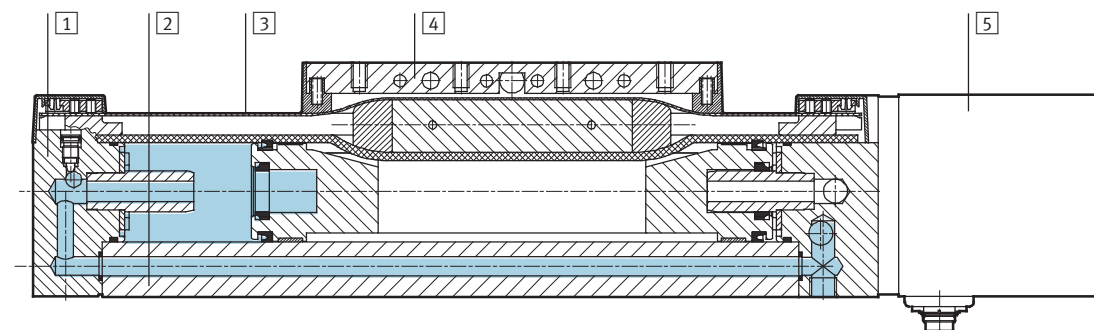

Drive		
1	End cap	Anodised aluminium
2	Profile	Anodised aluminium
3	Cover strip	Steel, corrosion resistant
4	Driver	Anodised aluminium
5	Displacement encoder housing	Anodised aluminium
-	Seals	Nitrile rubber, polyurethane

Note
 Further technical data
 → Internet: dgpl

Linear drives DGPI, integrated displacement encoder

Technical data



Characteristic load values

The forces and torques specified refer to the centre line of the profile barrel internal diameter.

They must not be exceeded during dynamic operation. Special attention must be paid to the cushioning phase.

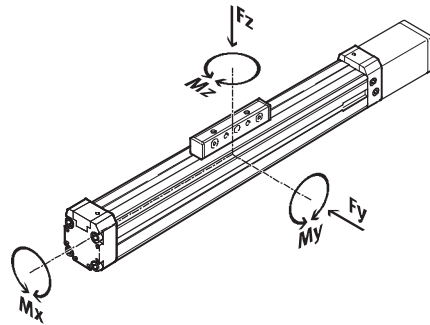

If the drive is subjected to more than two of the indicated forces and torques simultaneously, the following equations must be satisfied in addition to the indicated maximum loads.

$$0,4 \times \frac{F_z}{F_{z_{max}}} + \frac{M_x}{M_{x_{max}}} + \frac{M_y}{M_{y_{max}}} + 0,2 \times \frac{M_z}{M_{z_{max}}} \leq 1$$

$$\frac{F_z}{F_{z_{max}}} \leq 1 \quad \frac{M_z}{M_{z_{max}}} \leq 1$$

Permissible forces and torques

Piston Ø	25	32	40	50	63
F _y _{max.} [N]	–	–	–	–	–
F _z _{max.} [N]	330	480	800	1,200	1,600
M _x _{max.} [Nm]	1	2	4	7	8
M _y _{max.} [Nm]	20	40	60	120	120
M _z _{max.} [Nm]	3	5	8	15	24

Maximum permissible support span l as a function of the force F

The axis may need to be supported with central supports MUP in order to

limit deflection in the case of large strokes. The following diagrams serve

to determine the maximum permissible support span l as a

function of the force F.

Force on the surface of the slide

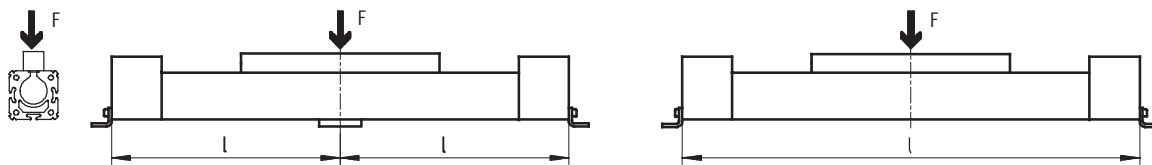

Maximum support span l (without central support) as a function of the force F

Piston Ø 25 ... 40

Piston Ø 50/63

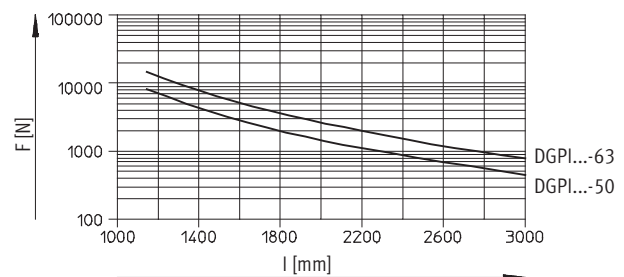
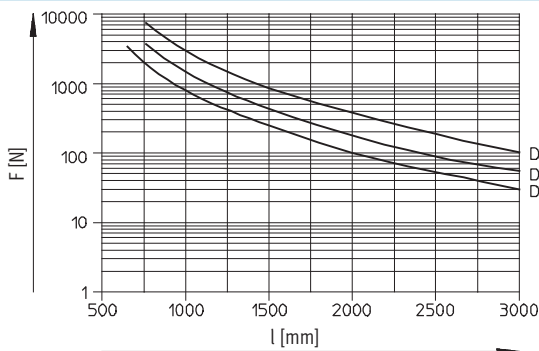

Linear drives DGPI, integrated displacement encoder

Technical data

Dimensions

Download CAD Data → www.festo.com/us/cad

Standard driver GK

Piston Ø 25

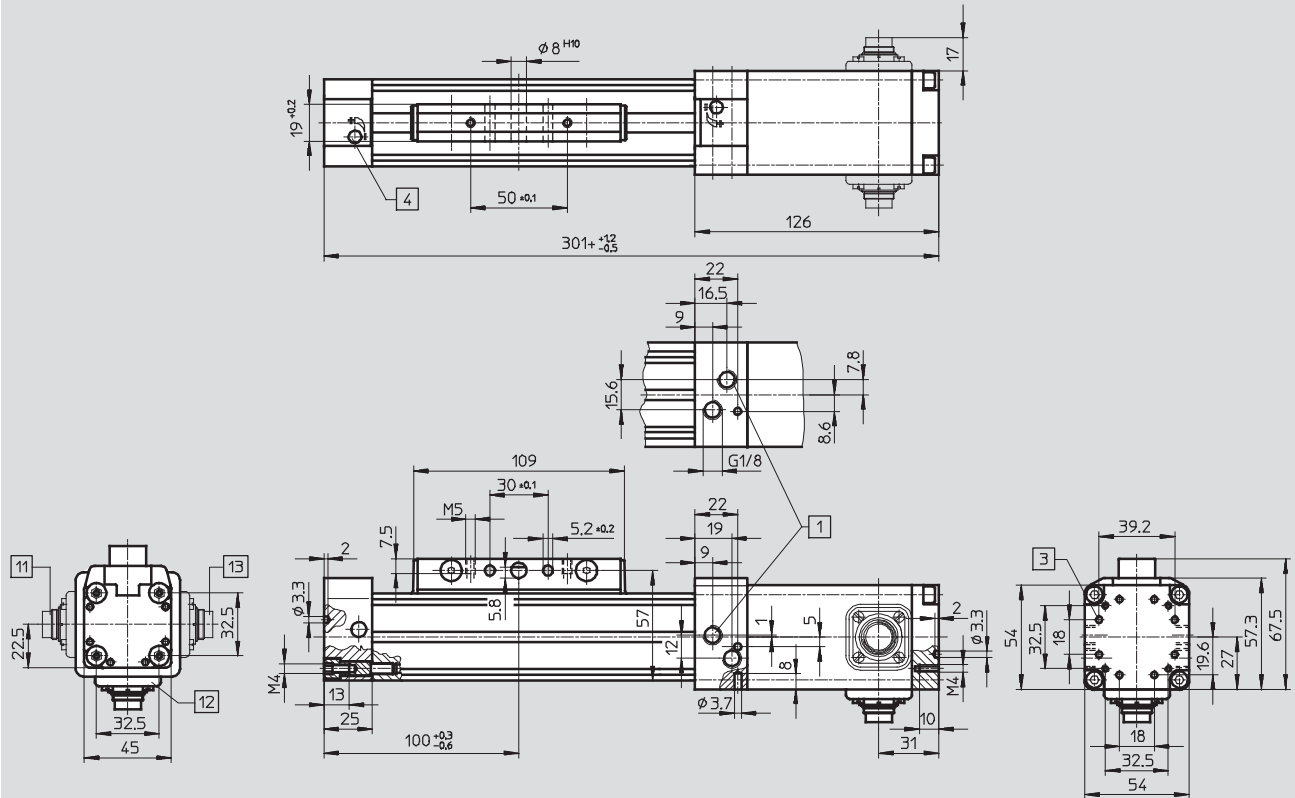

- 1 Both compressed air connections can be optionally connected to three sides of the right-hand end cap
 - 2 Regulating screw for adjustable end-position cushioning
 - 3 Mounting holes for foot mounting HP
 - 4 Encoder connection at rear
 - 5 Encoder connection underneath
 - 6 Encoder connection at front
- + = plus stroke length

Linear drives DGPI, integrated displacement encoder

Technical data

Dimensions

Download CAD Data → www.festo.com/us/cad

Supply port D2 at both sides

Piston Ø 25

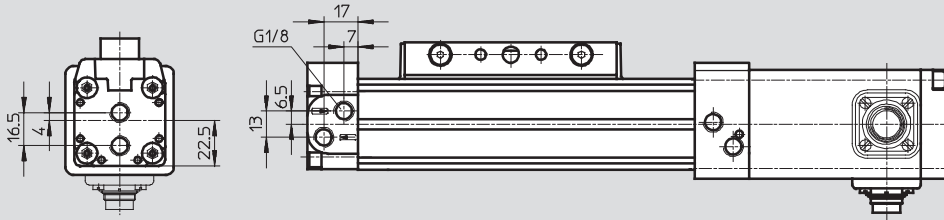

Profile barrel

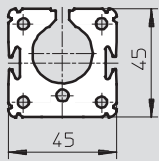

Linear drives DGPI, integrated displacement encoder

Technical data

Dimensions Download CAD Data → www.festo.com/us/cad

Profile barrel

Piston Ø 32

Piston Ø 40

Piston Ø 50

Piston Ø 63

6 Mounting slot for slot nuts NST

Ø	B1	B2	B3	B4	B5	B6	B11	D2	D3	D4	D5	D6
[mm]			+0.2					Ø	Ø		Ø	
									+0.2		H10	
32	54	35.8	19	46	21	40	9.5	4.3	5.2	M5	8	M5
40	64	45.7	21	53	28	49	9.5	4.3	6.5	M6	10	M5
50	90	69.2	24	76	44	72	12	6.3	8.5	M8	12	M6
63	106	84.8	24	89	44	83	12	6.3	8.5	M8	12	M8

Ø	EE	H1	H2	H3	H4	H5	H6	H9	H13	J1	J2	J3
[mm]												
32	G1/8	72	66	62	23	27	5.8	5	10.3	19	4.2	14
40	G1/4	86	78	71.8	26.5	32	7.7	5	12.75	22	5	21
50	G1/4	115	106	99	36	45	9.7	21.8	16.6	31.8	6.8	29.3
63	G3/8	131	122	115	44.5	53	9.7	-28	30	36	8	31

Ø	J4	J5	J6	J7	J8	L1	L2	L3	L4	L5	L6	L7
[mm]												±0.1
32	4.7	15.4	4.2	10.3	20.6	345	125	17	8.5	31	135	50
40	9.1	23	9.1	12.75	25.5	397	150	11.5	11.5	31	171	70
50	6	20.6	6.8	21	21	465	175	14	14	34	206	80
63	14	27	8	25	25	513	200	14	14	34	234	110

Ø	L8	L9	L10	L11	L12	L13	L14	L15	L16	T1	T2	T3	T6
[mm]	±0.1	±0.1											
32	100	30	17	8.5	19	126	27	26	9	13.2	3	7.5	12
40	130	40	10.8	16.5	21	128	29	26	10.8	13.2	4	10.5	12
50	150	50	10.8	18	22.8	149	80	25.2	12	15.2	6	12.5	15
63	190	70	14	24.5	31	147.5	68	16.5	16.5	21.2	6	12.5	20

Linear drives DGPI, integrated displacement encoder

Ordering data – Modular product system

Order code

Mandatory data/Options

- AK Load inverter
- D2 Air connection at both ends
- GK Standard slide

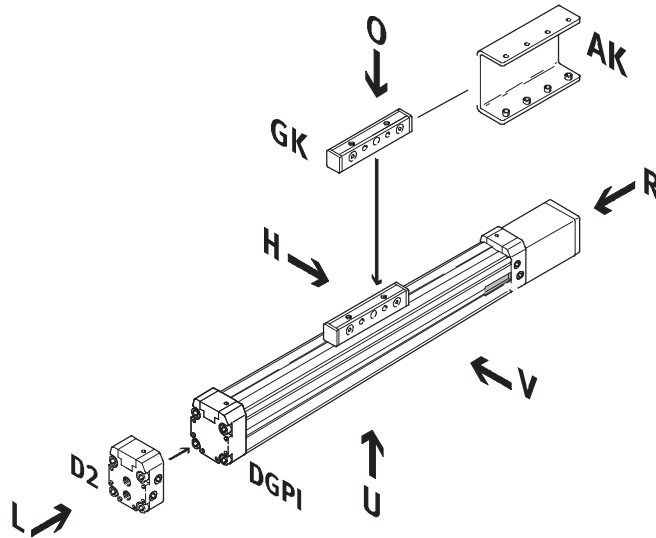

- AV Displacement encoder connection to front
- AH Displacement encoder connection to rear
- AU Displacement encoder connection underneath

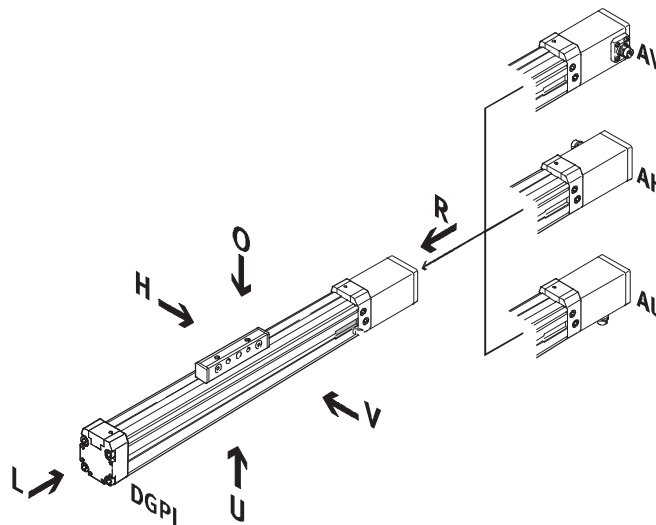

Linear drives DGPI, integrated displacement encoder

Ordering data – Modular product system

FESTO

Order code

Options

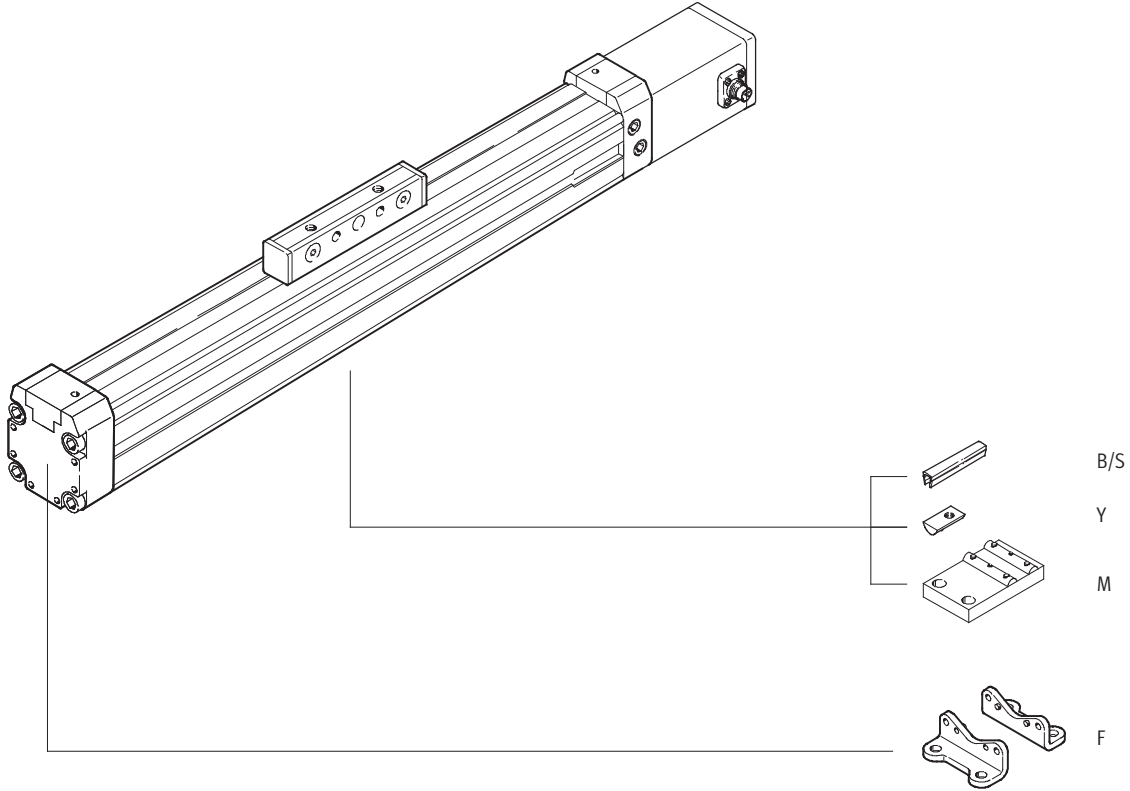

Linear drives DGPI, integrated displacement encoder

Ordering data – Modular product system

M Mandatory data →

Module No.	Drive function	Size	Stroke	Cushioning	Displacement encoder	Basic variant	Connection position for displacement encoder
175 134	DGPI	25	225 ... 2 000	PPV	AIF	GK	AH
175 135		32					AU
175 136		40					AV
175 137		50					
175 138		63					
Ordering example							
175 138	DGPI	- 63	- 750	- PPV	- AIF	- GK	- AV

Ordering table								
Size	25	32	40	50	63	Conditions	Code	Enter code
M Module No.	175 134	175 135	175 136	175 137	175 138			
Drive function	Pneumatic linear drive with integrated displacement encoder						DGPI	DGPI
Size	25	32	40	50	63		-...	
Stroke [mm]	225, 300, 360, 450, 500, 600, 750, 1 000, 1 250, 1 500, 1 750, 2 000						-...	
Cushioning	Pneumatic cushioning adjustable at both ends						-PPV	-PPV
Displacement encoder	Temposonic with CAN axis interface						-AIF	-AIF
Basic variant	Standard piston/slide						-GK	-GK
Connection position for displacement encoder AIF and compressed air	Connection position for displacement encoder and air supply port, rear						-AH	
	Connection position for displacement encoder and air supply port, underneath						-AU	
	Connection position for displacement encoder and air supply port, front						-AV	

Transfer order code

Linear drives DGPI, integrated displacement encoder

Ordering data – Modular product system

Options					
Driver/Air supply port	Accessories	Slot cover	Slot nut	Central support	Foot mounting
AK D2	ZUB	...S ...B	...Y	...M	...F
- AK	: ZUB	- 2B2S	10Y		F

Ordering table									
Size	25	32	40	50	63	Conditions	Code	Enter code	
↓ Driver	Load inverter						-AK		
○ Air supply port	at both ends						-D2		
Accessories	Supplied separately						:ZUB-	:ZUB-	
Slot cover, x2, 0.5 m	Sensor slot	1 ... 10					...S		
	Mounting slot	-	1 ... 10					...B	
Slot nut	Mounting slot	-	1 ... 10					...Y	
	Mounting slot	-	1 ... 10					...M	
Central support	1 ... 10						...M		
Foot mounting	1 ... 10						...F		

Transfer order code

- : -

Linear drives DGPIIL, integrated displacement encoder

Peripherals overview

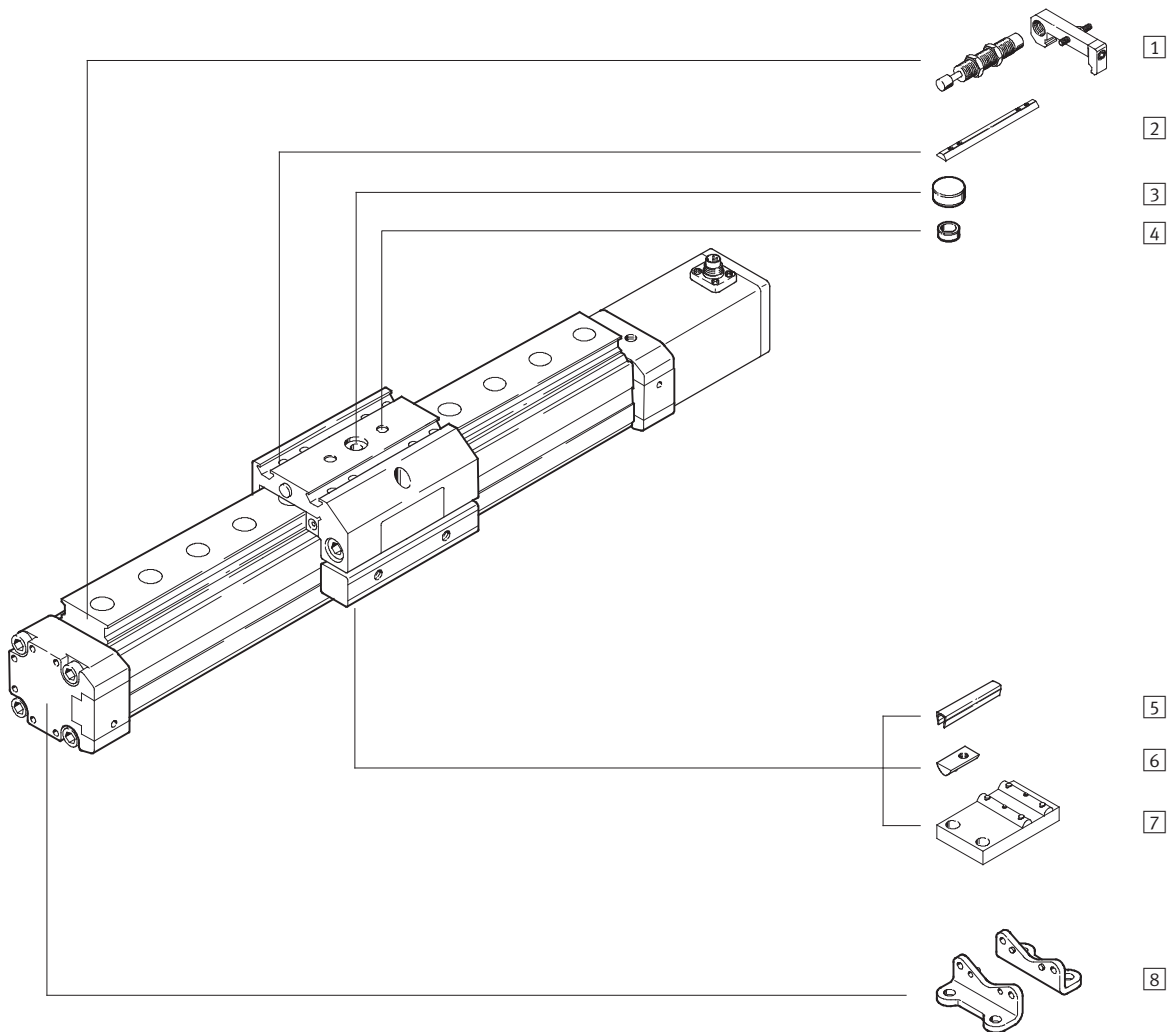

Linear drives DGPII, integrated displacement encoder

Peripherals overview

Variants and accessories		
Type	Brief description	→ Page/Internet
1 Shock absorber kit C/E	to avoid damage at the end stop, in the event of malfunctions	119
2 Slot nut for slide X	for mounting loads and attachments on the slide	120
3 Central mounting Q	for centring loads and attachments on the slide	120
4 Centring sleeves Z	for centring loads and attachments on the slide	120
5 Slot cover B/S	to protect against the ingress of dirt	120
6 Slot nut for mounting slot Y	for mounting attachments	120
7 Central support M	to mount the axis	117
8 Foot mounting F	to mount the axis	117

Linear drives DGPII, integrated displacement encoder

Type codes

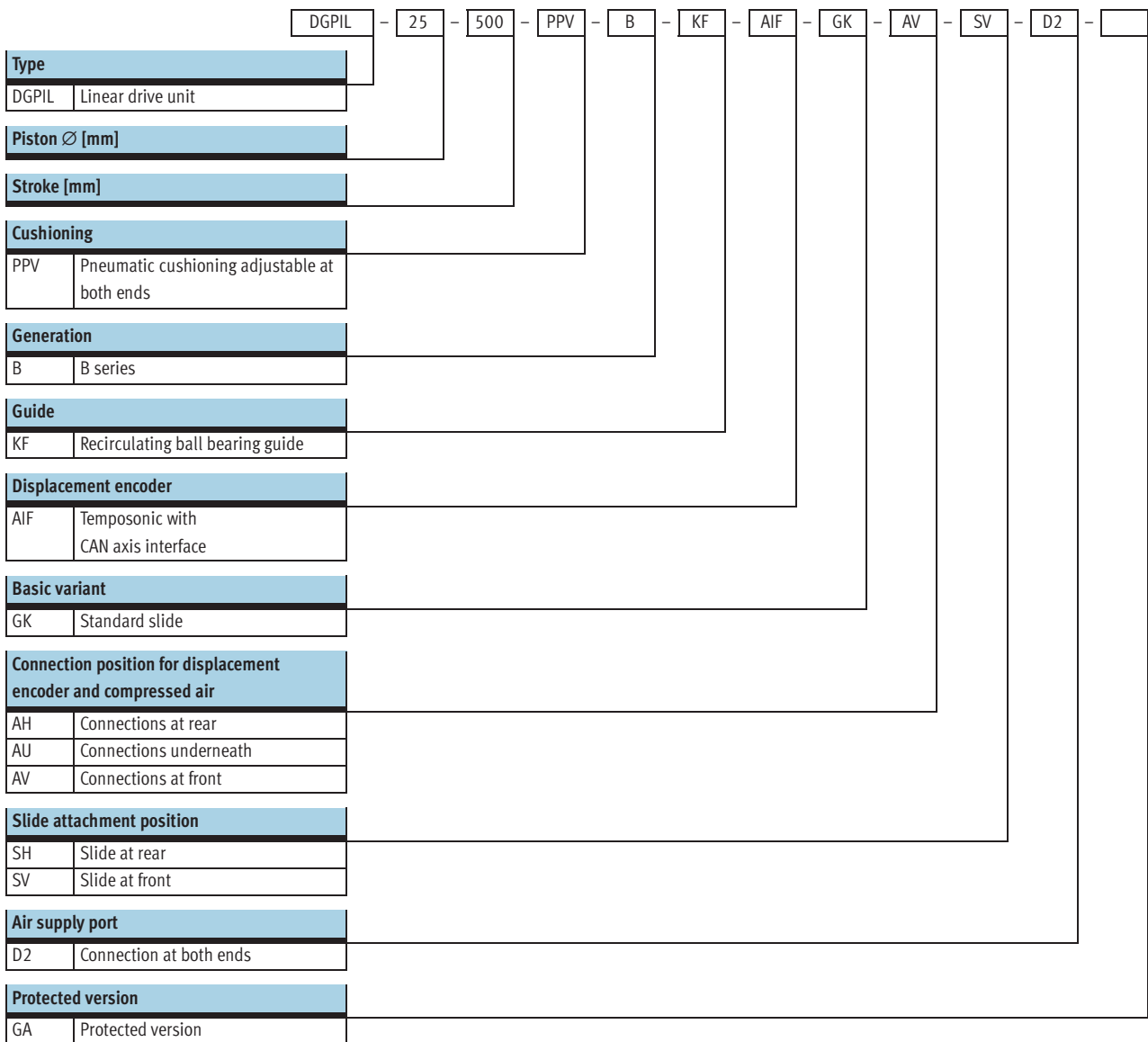

Linear drives DGPII, integrated displacement encoder

Type codes

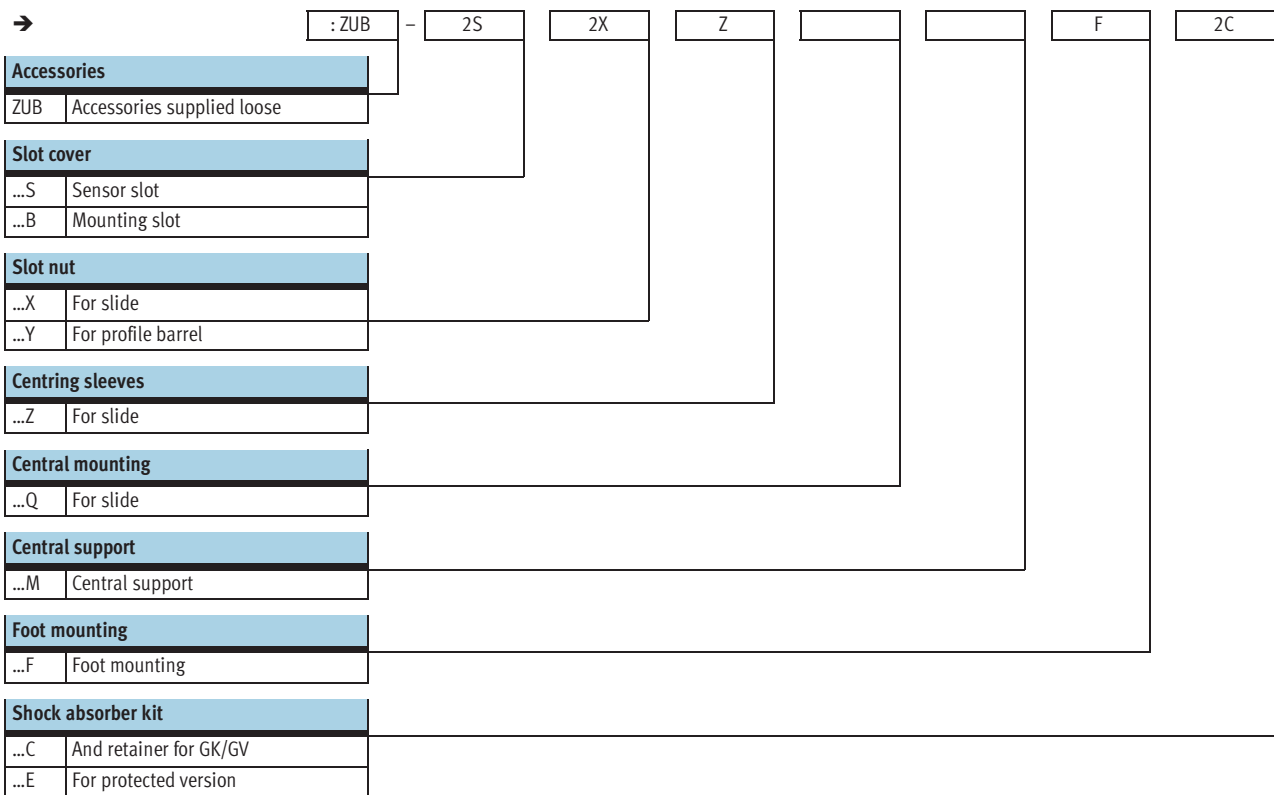

Linear drives DGPII, integrated displacement encoder

Technical data

Function

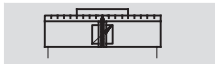

- N- Diameter
25 ... 63 mm
- T- Stroke length
225 ... 2,000 mm



General technical data					
Piston Ø	25	32	40	50	63
Design	Piston Driver Profile barrel				
Mode of operation	Double-acting				
Operating medium ¹⁾	Compressed air, filtered and unlubricated, filter unit 5 µm				
Cushioning	Pneumatic cushioning adjustable at both ends				
Cushioning length [mm]	18	20	30		
Position sensing	Integrated displacement encoder				
Measuring principle	Digital, magnetostrictive, non-contacting, absolute measurement				
Type of mounting	Foot mounting				
Stroke ²⁾³⁾ [mm]	225, 300, 360, 450, 500, 600, 750, 1,000, 1,250, 1,500, 1,750, 2,000				
Protection against torsion/guide	Guide rail with slide Recirculating ball bearing				
Protected version ⁴⁾	Optional				
Pneumatic connection	G1/8		G1/4		G3/8
Electrical connection	6-pin round plug to DIN 45 322				

- 1) The proportional directional control valve MPYE used requires the characteristic values.
- 2) Note stroke reduction in conjunction with SPC200.
- 3) Supply of compressed air to each end of the cylinder (feature D2) is absolutely essential for Soft Stop SPC11 and axis controller SPC200 as of a length of 500 mm.
- 4) Protected from above and the sides against the ingress of particles

Forces [N] and impact energy [Nm]					
Piston Ø	25	32	40	50	63
Theoretical force at 6 bar	295	483	754	1,178	1,870
Max. impact energy at the end positions ¹⁾	0.1	0.2	0.4	0.8	0.8

- 1) Cushioning PPV must be completely open for applications with Soft Stop SPC11 and axis controller SPC200.

Permissible impact velocity:

$$v_{perm.} = \sqrt{\frac{2 \times E_{perm.}}{m_{dead} + m_{load}}}$$

- $v_{perm.}$ Permissible impact velocity
- $E_{perm.}$ Max. impact energy
- m_{dead} Moving load (drive)
- m_{load} Moving work load

Maximum permissible load:

$$m_{load} = \frac{2 \times E_{perm.}}{v^2} - m_{dead}$$

Note

These specifications represent the maximum values which can be reached. Note the maximum permitted impact energy.

Linear drives DGPII, integrated displacement encoder

Technical data

Positioning characteristics with axis controller SPC200					
Piston Ø	25	32	40	50	63
Repetition accuracy [mm]	→ 77				
Mounting position	Any				
Minimum load, horizontal ¹⁾ [kg]	2	3	5	8	12
Maximum load, horizontal ¹⁾ [kg]	30	45	75	120	180
Minimum load, vertical ¹⁾ [kg]	2	3	5	8	12
Maximum load, vertical ¹⁾ [kg]	10	15	25	40	60
Min. speed of travel [m/s]	0.05				
Max. speed of travel [m/s]	3				
Typ. positioning time, long stroke ²⁾ [s]	0.75/1.20	0.85/1.20	0.75/1.20	0.95/1.25	0.90/1.20
Typ. positioning time, short stroke ³⁾ [s]	0.40/0.60	0.45/0.60	0.40/0.60	0.50/0.65	0.50/0.65
Minimum positioning stroke ⁴⁾ [%]	3				
Stroke reduction ⁵⁾ [mm]	25		35		
Recommended proportional directional control valve	→ 121				

- 1) Load = effective load + mass of all moving parts on the drive
- 2) At 6 bar, horizontal mounting position, DGPII-XX-1250, 1000 mm positioning travel at min./max. load
- 3) At 6 bar, horizontal mounting position, DNCM-XX-1250, 100 mm positioning travel at min./max. load
- 4) In relation to the maximum stroke of the drive, but never more than 20 mm.
- 5) The stroke reserve is to be maintained on every side of the drive, the max. positionable stroke is therefore: Stroke – 2x stroke reserve

Positioning characteristics with end position controller SPC11					
Piston Ø	25	32	40	50	63
Repetition accuracy of a mid-position ¹⁾ [mm]	±2				
Mounting position	Any				
Minimum load, horizontal ²⁾ [kg]	2	3	5	8	12
Maximum load, horizontal ²⁾ [kg]	30	45	75	120	180
Minimum load, vertical ²⁾ [kg]	2	3	5	8	12
Maximum load, vertical ²⁾ [kg]	10	15	25	40	60
Travel time [s]	→ Sizing software "Smart Soft Stop": → www.festo.com				
Recommended proportional directional control valve	→ 121				

- 1) In the stroke range from 225 ... 2,000 mm
- 2) Load = effective load + mass of all moving parts on the drive

Operating and environmental conditions					
Piston Ø	25	32	40	50	63
Operating pressure ¹⁾ [bar]	4 ... 8				
Ambient temperature [°C]	-10 ... +60				
Vibration resistance	To DIN/IEC 68 Parts 2 -6, severity level 1				
Continuous shock resistance	To DIN/IEC 68 Parts 2 -27, severity level 1				
CE marking symbol (see conformity declaration)	As per EU EMC directive				
Protection class (displacement encoder)	IP65 to IEC 60 529				

- 1) Only applies for applications with Soft Stop SPC11 and axis controller SPC200.

Linear drives DGPII, integrated displacement encoder

Technical data

Weights [g]					
Piston \varnothing	25	32	40	50	63
Standard slide GK					
Basic weight	2,220	3,320	5,330	10,700	16,870
Additional weight per 10 mm stroke	55	71	99	186	256
Moving load	605	895	1,700	3,000	4,990
Additional weights for protected version GA					
Dirt protection cover	1,690	2,500	4,000	–	–
Additional weight per 10 mm stroke	26	42	65	–	–
Moving load	907	1,350	2,550	–	–

Electrical data, displacement encoder		
Power supply	[V DC]	24 (-15/+25%)
Max. current consumption	[mA]	90
Resolution	[mm]	≤ 0.01
Independent linearity ¹⁾	maximum [%]	0.02
Temperature coefficient	[ppm/°K]	≤ 15
Interface		Digital, CAN with protocol: SPC-AIF

1) Minimum $\pm 50 \mu\text{m}$

Materials

Sectional view

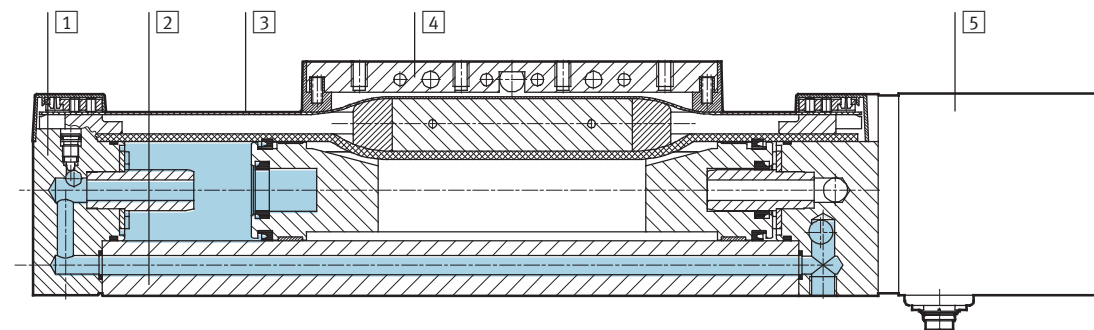

Drive		
1	End cap	Anodised aluminium
2	Profile	Anodised aluminium
3	Cover strip	Steel, corrosion resistant
4	Driver	Anodised aluminium
5	Displacement encoder housing	Anodised aluminium
–	Slide	Anodised aluminium
–	Guide rail	Corrosion resistant steel
–	Seals	Nitrile rubber, polyurethane

Note
 Further technical data
 → Internet: dgpl

Linear drives DGPI, integrated displacement encoder

Technical data



Characteristic load values

The forces and torques specified refer to the centre line of the profile barrel internal diameter.

They must not be exceeded during dynamic operation. Special attention must be paid to the cushioning phase.

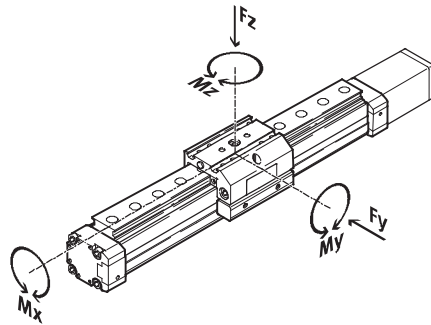

If the drive is subjected to more than two of the indicated forces and torques simultaneously, the following equations must be satisfied in addition to the indicated maximum loads.

$$\frac{F_y}{F_{y_{max}}} + \frac{F_z}{F_{z_{max}}} + \frac{M_x}{M_{x_{max}}} + \frac{M_y}{M_{y_{max}}} + \frac{M_z}{M_{z_{max}}} \leq 1$$

Permissible forces and torques

Piston Ø		25	32	40	50	63
F _y _{max.}	[N]	3,080	3,080	7,300	7,300	14,050
F _z _{max.}	[N]	3,080	3,080	7,300	7,300	14,050
M _x _{max.}	[Nm]	45	63	170	240	580
M _y _{max.}	[Nm]	85	127	330	460	910
M _z _{max.}	[Nm]	85	127	330	460	910

Maximum permissible support span l as a function of the force F

The axis may need to be supported with central supports MUP in order to

limit deflection in the case of large strokes. The following diagrams serve

to determine the maximum permissible support span l as a

function of the force F.

Force on the surface of the slide

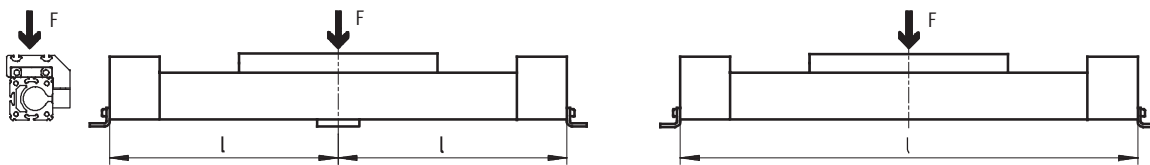

Maximum support span l (without central support) as a function of the force F

Piston Ø 25 ... 40

Piston Ø 50/63

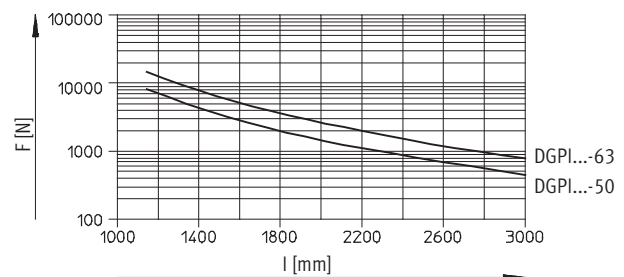
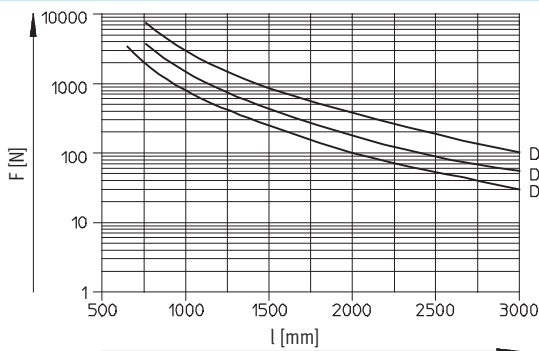

Linear drives DGPII, integrated displacement encoder

Technical data

Dimensions

Download CAD Data → www.festo.com/us/cad

Standard slide GK

Piston Ø 25

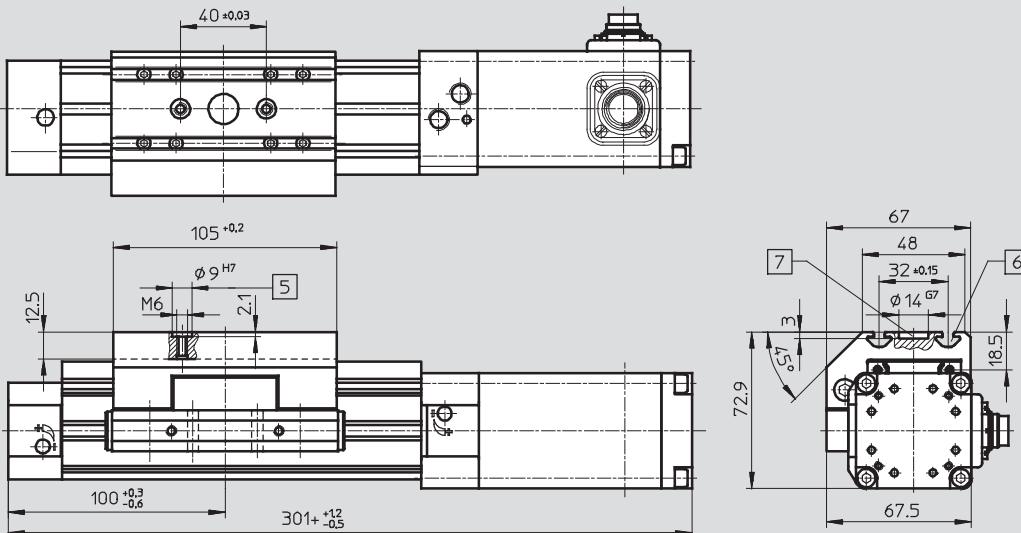

- 5 Hole for centring sleeve ZBH-9
 - 7 Drilled hole for central mounting SLZZ
 - 6 Mounting slot for slot nut NSTL
- + = plus stroke length

Basic dimensions
→ 95

Protected version GA

Piston Ø 25

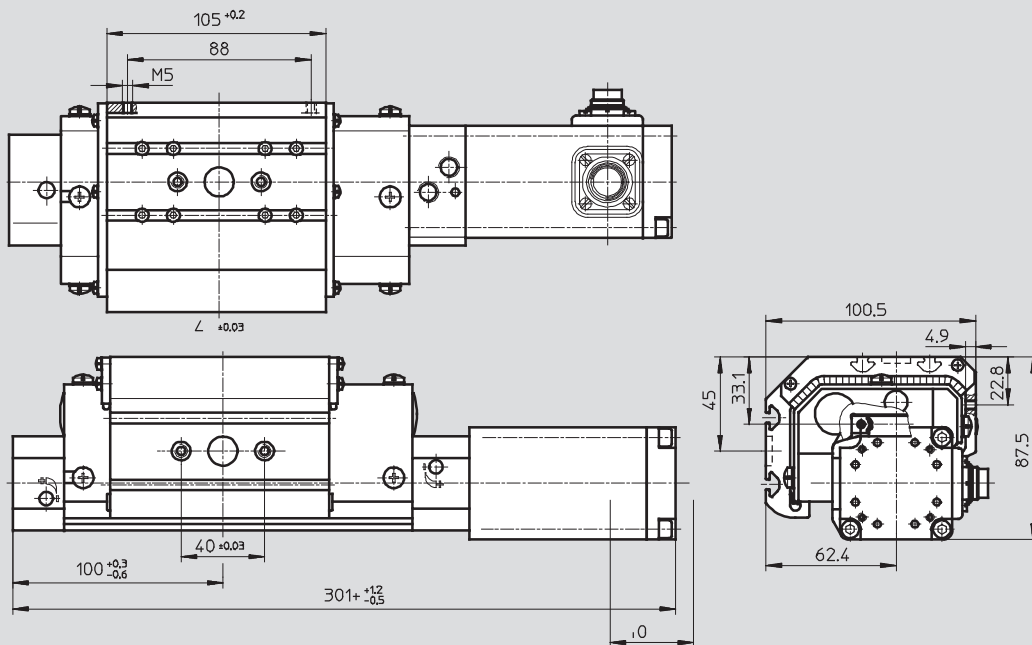

+ = plus stroke length

Basic dimensions
→ 95

Linear drives DGPII, integrated displacement encoder



Technical data

Dimensions Download CAD Data → www.festo.com/us/cad

Standard slide GK
Piston Ø 32 ... 63

- 5 Hole for centring sleeve ZBH-9
- 6 Mounting slot for slot nut NSTL
- 7 Drilled hole for central mounting SLZZ

+ = plus stroke length

Basic dimensions
→ 97

Protected version GA
Piston Ø 32/40

+ = plus stroke length

Basic dimensions
→ 97

Ø [mm]	B7	B8	B9	B10 ±0.03	B12	B14	D1	H1	H7	H8	H10
32	63	79	47 ±0.15	20	112.1	67.6	-	72	77.5	18.5	93.1
40	78.5	96.5	55 ±0.2	20	137.6	79.6	M5	86	90.5	20	106.6
50	97	122	72 ±0.2	40	-	-	-	115	122.5	26	-
63	121	142	90 ±0.25	40	-	-	-	131	144.5	30	-

Ø [mm]	H11	H12	H14	L1	L2	L17 +0.2	L18 ±0.03	L19 ±0.03	L23	L24	L25	T4 max.	T5
32	-	49.5	34.1	345	125	131	40	-	131	-	-	12.5	-
40	23.1	54	36.1	397	150	167	40	40	167	150	58	12.5	7
50	-	-	-	465	175	202	40	40	-	-	-	18.5	-
63	-	-	-	513	200	230	40	40	-	-	-	20.5	-

Linear drives DGPIIL, integrated displacement encoder

Ordering data – Modular product system

Order code

Mandatory data

- KF Recirculating ball bearing guide
- SH Slide at rear
- SV Slide at front
- D2 Air connection at both ends
- GK Standard slide

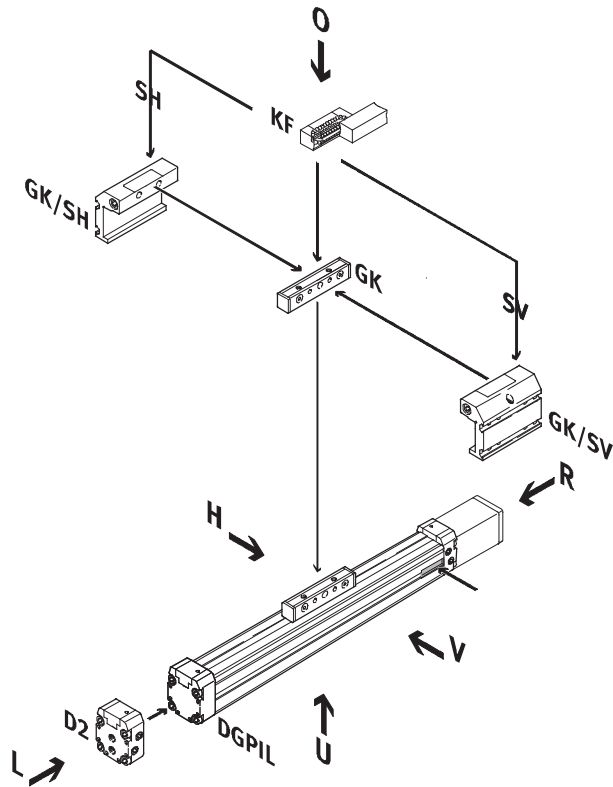

- AV Displacement encoder connection to front
- AH Displacement encoder connection to rear
- AU Displacement encoder connection underneath

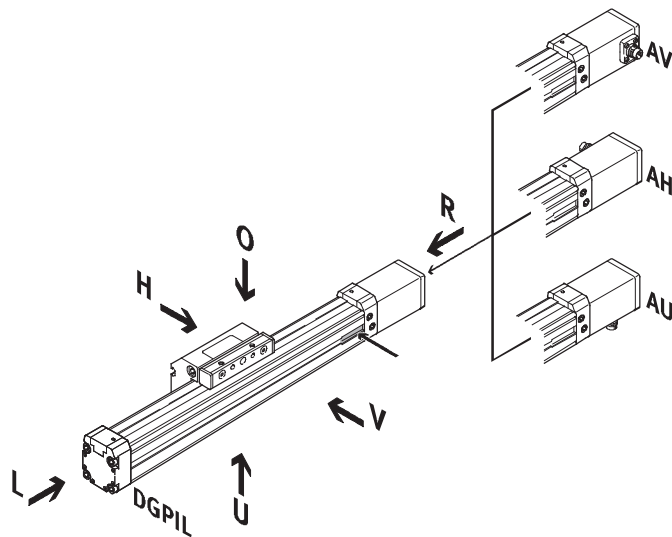

- GA Protected version

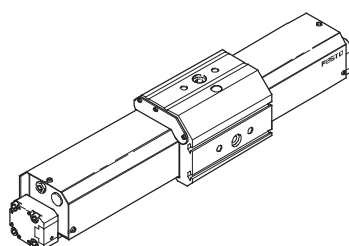

Linear drives DGPIIL, integrated displacement encoder

Ordering data – Modular product system

FESTO

Order code

Options

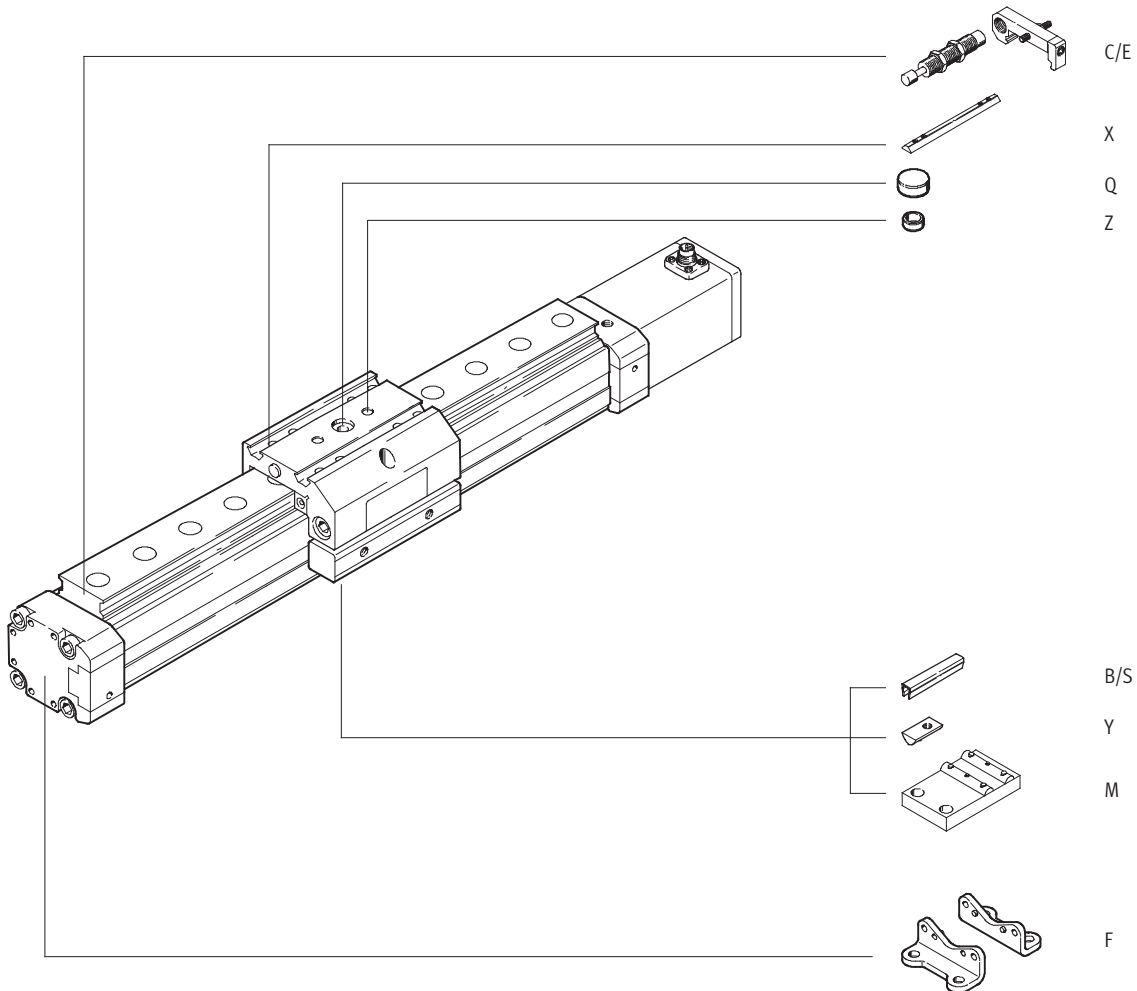

Linear drives DGPII, integrated displacement encoder

Ordering data – Modular product system

M Mandatory data →

Module No.	Drive function	Size	Stroke	Cushioning	Generation	Guide	Displacement encoder	Basic variant	Connection position for displacement encoder	Slide attachment position
175 134	DGPII	25	225 ...	PPV	B	KF	AIF	GK	AH AU AV	SH SV
175 135		32	2 000							
175 136		40								
175 137		50								
175 138		63								
Ordering example										
175 134	DGPII	- 25	- 450	- PPV	- B	- KF	- AIF	- GK	- AU	- SH

Ordering table

Size	25	32	40	50	63	Conditions	Code	Enter code
M Module No.	175 134	175 135	175 136	175 137	175 138			
Drive function	Pneumatic linear drive with integrated displacement encoder and slide						DGPII	DGPII
Size	25	32	40	50	63		-...	
Stroke [mm]	225, 300, 360, 450, 500, 600, 750, 1 000, 1 250, 1 500.1 750, 2 000						-...	
Cushioning	Pneumatic cushioning adjustable at both ends						-PPV	-PPV
Generation	B series						-B	-B
Guide	Recirculating ball bearing guide						-KF	-KF
Displacement encoder	Temposonic with CAN axis interface						-AIF	-AIF
Basic variant	Standard piston/slide						-GK	-GK
Connection position for displacement encoder AIF and compressed air	Connection position for displacement encoder and air supply port, rear						-AH	
	Connection position for displacement encoder and air supply port, underneath						-AU	
	Connection position for displacement encoder and air supply port, front						-AV	
Slide attachment position	Slide at rear						-SH	
	Slide at front						-SV	

Transfer order code

Linear drives DGPII, integrated displacement encoder

Ordering data – Modular product system

Options									
Air supply port	Protected version	Accessories	Slot cover	Slot nut	Centring sleeve	Central support	Central mounting	Foot mounting	Shock absorber
D2	GA	ZUB	...S ...B	...X ...Y	...Z	...M	...Q	...F	...C ...E
- D2	-	: ZUB	- 2S2B	2X				F	2C

Ordering table											
Size	25	32	40	50	63	Conditions	Code	Enter code			
▼ Air supply port	at both ends							-D2			
0 Protected version	Protected roller bearing design for harsh environment			-	-	-		-GA			
Accessories	Supplied separately							:ZUB-	:ZUB-		
Slot cover, x2, 0.5 m	Sensor slot	1 ... 10							...S		
	Mounting slot	-	1 ... 10							...B	
Slot nut	Slide	1 ... 10							...X		
	Mounting slot	-	1 ... 10							...Y	
Centring sleeve (pack of 10)	10, 20, 30, 40, 50, 60, 70, 80, 90							...Z			
Central support	1 ... 10							...M			
Central mounting	1 ... 10							...Q			
Foot mounting	1 ... 10							...F			
Shock absorber kit	with retainer, 1-off	1 ... 10						1	...C		
		1 ... 10						-	...E		

- 1 C Not with protected version GA.
- 2 E Only with protected version GA.

Transfer order code

- - : ZUB -

Linear drives DGPL/DGPI/DGPIL

Accessories

Foot mounting HP (Order code: F)



Material:
Galvanised steel

Free of copper, PTFE and silicone

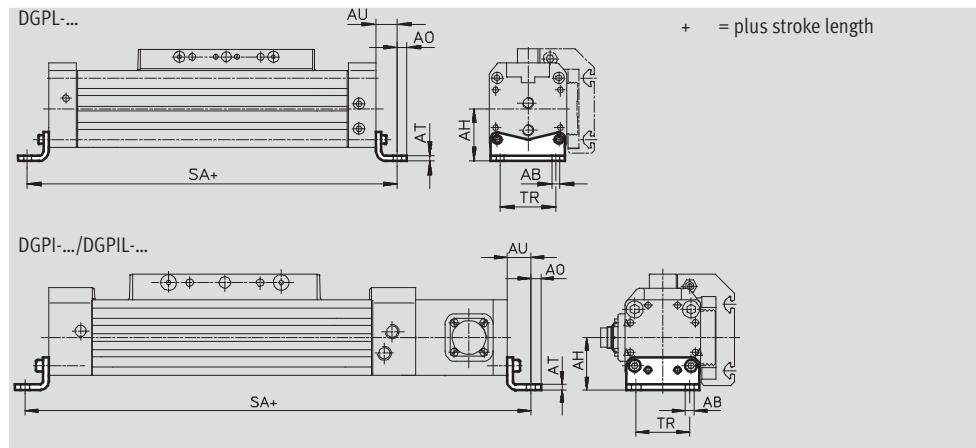

Dimensions and ordering data											
for \varnothing [mm]	AB \varnothing	AH	AO	AT	AU	SA		TR	Weight [g]	Part No.	Type
						DGPL	DGPI(L)				
25	5.5	29.5	6	3	13	226	327	32.5	61	150 731	HP-25
32	6.6	37	7	4	17	284	379	38	117	150 732	HP-32
40	6.6	46	8.5	5	17.5	335	432	45	188	150 733	HP-40
50	9	61	11	6	25	400	515	65	243	150 734	HP-50
63	11	69	13.5	6	28	456	569	75	305	150 735	HP-63

Central support MUP (Order code: M)



MUP-40

Material:
Galvanised steel

Free of copper, PTFE and silicone

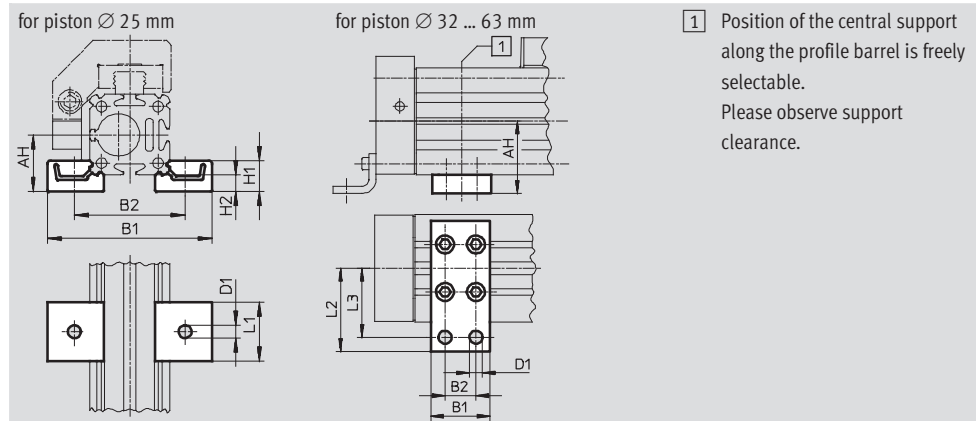

Dimensions and ordering data												
for \varnothing [mm]	AH	B1	B2	D1 \varnothing	H1	H2	L1	L2	L3	Weight [g]	Part No.	Type
32	37	35	22	6.6	-	-	-	41.5	35	89	150 737	MUP-32
40	46	35	22	6.6	-	-	-	47	40	126	150 738	MUP-40
50	61	50	26	11	-	-	-	70	58	241	150 739	MUP-50
63	69	50	26	11	-	-	-	77	65	340	150 800	MUP-63

Linear drives DGPL/DGPI/DGPIL

FESTO

Accessories

Load inverter AK

for DGPI

(Order code: AK)

Material:

Galvanised steel

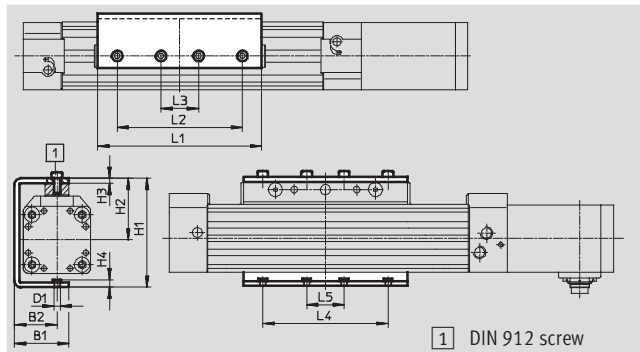
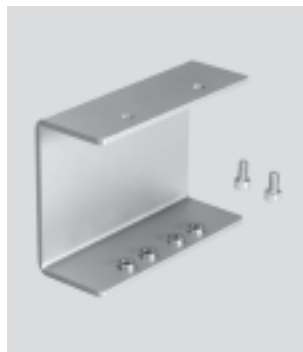

Dimensions and ordering data									
for \varnothing	B1	B2	D1	H1	H2	H3	H4	L1	L2
[mm]									
25	39	29.5	M5	76.1	43.5	3	5	105	-
32	43.5	34	M5	87	49	4	6	131	100
40	50.5	40	M6	104	58	4	8.1	167	130
50	67	55	M8	138.5	75	5	10.5	202	150
63	77	65	M8	156.5	84	6	11.5	230	190

for \varnothing	L3	L4	L5	[1]	CRC ¹⁾	Weight	Part No.	Type
[mm]						[g]		
25	50	50	20	M5x10	2	380	196 106	AK-25
32	30	100	30	M5x12		690	196 107	AK-32
40	40	130	40	M6x14		1,050	196 108	AK-40
50	50	150	50	M8x16		2,080	196 109	AK-50
63	70	190	70	M8x18		2,820	196 110	AK-63

1) Corrosion resistance class 2 according to Festo standard 940 070

Components requiring moderate corrosion resistance. Externally visible parts with primarily decorative surface requirements which are in direct contact with a surrounding industrial atmosphere or media such as cooling or lubricating agents.

Shock absorber DG-GA

for DGPIL

Protected version GA

(Order code: E)

Material:

Housing: Galvanised steel; piston rod:

high-alloy steel

Seals: Perbunan, polyurethane

Free of copper, PTFE and silicone



Ordering data		
for \varnothing	Weight	Part No. Type
[mm]	[g]	
25	70	192 875 DG-GA-25-YSR
32	110	192 876 DG-GA-32-YSR
40	140	192 877 DG-GA-40-YSR

Linear drives DGPL/DGPI/DGPIL

Accessories

Shock absorber YSR-...-C

for DGPL/DGPIL

(Order code: C)

Material:

Housing: Galvanised steel; piston rod: high-alloy steel,

Seals: Perbunan, polyurethane

Free of copper, PTFE and silicone



Note

Shock absorber YSRW with progressive characteristic

→ Internet: ysrw

Ordering data			
for Ø [mm]	Weight [g]	Part No.	Type
25	70	34 572	YSR-12-12-C
32	70	34 572	YSR-12-12-C
40	140	34 573	YSR-16-20-C
50	140	34 573	YSR-16-20-C
63	240	34 574	YSR-20-25-C

Shock absorber retainer KYP

for DGPL/DGPIL

(Order code: C)

Material:

Retainer: Aluminium

Sleeve: Steel, corrosion resistant

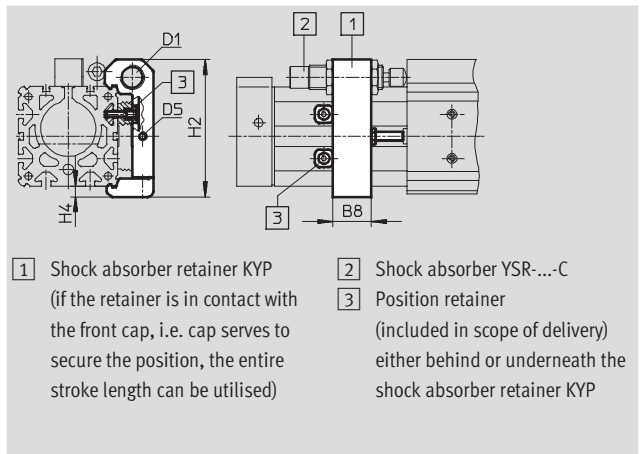



Dimensions and ordering data								
for Ø [mm]	B8	D1	D5	H2	H4	Weight [g]	Part No.	Type
25	19	M16x1	M5	69.5	6	95	158 908	KYP-25
32	25	M16x1	M5	80	8	130	158 909	KYP-32
40	32	M22x1.5	M5	102	8	209	158 910	KYP-40
50	35	M22x1.5	M8	124	10	415	158 911	KYP-50
63	44	M26x1.5	M10	152.5	11.5	609	158 912	KYP-63

Linear drives DGPL/DGPI/DGPIL

Accessories

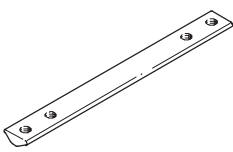
FESTO

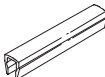
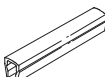
Ordering data						
	for Ø [mm]	Remarks	Order code	Part No.	Type	PU ¹⁾
Slot nut NST Technical data → Internet: nst						
	25	For mounting slot	Y	526 091	NST-HMV-M4	1
	32, 40			150 914	NST-5-M5	1
	50, 63			150 915	NST-8-M6	1
Slot nut NSTL Technical data → Internet: nstl						
	25	For slide	X	158 410	NSTL-25	1
	32			158 411	NSTL-32	1
	40			158 412	NSTL-40	1
	50			158 413	NSTL-50	1
	63			158 414	NSTL-63	1
Centring sleeve ZBH Technical data → Internet: zbh						
	25 ... 63	For slide	Z	150 927	ZBH-9	10
Central mounting SLZZ Technical data → Internet: slzz						
	25	For slide	Q	150 900	SLZZ-16/10	1
	32, 40			150 901	SLZZ-25/16	1
	50, 63			150 904	SLZZ-50/40	1
Slot cover ABP Technical data → Internet: abp						
	32, 40	For mounting slot 0.5 m each	B	151 681	ABP-5	2
	50, 63			151 682	ABP-8	
Slot cover ABP-S Technical data → Internet: abp						
	25 ... 63	For sensor slot 0.5 m each	S	563 360	ABP-5-S1	2

1) Packaging unit quantity

Ordering data – Push-in/threaded fittings						
	for Ø [mm]	Remarks	Order code	Part No.	Type	PU ¹⁾
	25, 32	For connecting compressed air tubing		186 098	QS-G$\frac{1}{8}$-8	10
	40, 50			186 099	QS-G$\frac{1}{4}$-8	
	63			186 101	QS-G$\frac{1}{4}$-10	10
				186 100	QS-G$\frac{3}{8}$-8	10
				186 102	QS-G$\frac{3}{8}$-10	
				186 103	QS-G$\frac{3}{8}$-12	

1) Packaging unit quantity

Linear drives DGPL/DGPI/DGPIL

Accessories

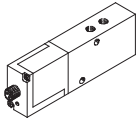
Ordering data – Proportional directional control valves										Technical data → Internet: mpye				
Selection aid														
Application	for Ø [mm]	Stroke [mm]												
		225	300	360	450	500	600	750	1,000	1,250	1,500	1,750	2,000	
horizontal/vertical	For applications with axis controller SPC200													
	25	1/1	1/1	1/1	1/1	1/1	1/1	1/1	2/2	2/2	2/2	2/2	2/2	
	32	1/1	1/1	2/2	2/2	2/2	2/2	2/2	2/2	2/2	2/2	2/2	2/2	
	40	1/1	2/2	2/2	2/2	2/2	2/2	2/2	3/3	3/3	3/3	3/3	3/3	
	50	2/2	2/2	2/2	2/2	2/2	3/3	3/3	3/3	3/3	3/3	3/3	3/3	
	63	3/3	3/3	3/3	3/3	3/3	3/3	3/3	3/3	4/4	4/4	4/4	4/4	
	For applications with Soft Stop end position controller SPC11													
	25	1 ¹⁾	1/1	2/1	2/1	2/1	2/2	2/2	2/3	2/3	2/3	2/3	2/3	
	32	1 ¹⁾	2/1	2/1	2/1	2/1	2/1	3/2	3/3	3/3	3/3	3/3	3/3	
	40	2/1	2/1	2/1	2/1	2/2	3/3	3/4	3/4	3/4	3/4	3/4	3/4	
	50	1/1	2/1	2/2	3/2	3/3	4/3	4/4	4/4	4/4	4/4	4/4	4/4	
	63	2/1	2/2	3/3	3/3	4/4	4/4	4/4	4/4	4/4	4/4	4/4	4/4	
	Valve	Selection number							Part No.	Type				
		1							151 692	MPYE-5-1/8-LF-010-B				
2							151 693	MPYE-5-1/8-HF-010-B						
3							151 694	MPYE-5-1/4-010-B						
4							151 695	MPYE-5-3/8-010-B						

1) On request

Note



The representation e.g. 2/1 in the columns means:



Selection number 2	Selection number 1
for horizontal application	for vertical application
151 693 MPYE-5-1/8-HF-010-B	151 692 MPYE-5-1/8-LF-010-B



Linear drives DGPI/DGPI/DGPIL

Accessories

FESTO

Ordering data – Proximity sensors for T-slot, magneto-resistive					Technical data → Internet: smt	
	Type of mounting	Switch output	Electrical connection	Cable length [m]	Part No.	Type
N/O contact						
	Insertable in the slot lengthwise, flush with the cylinder profile	PNP	Plug M8x1, 3-pin	0.3	175 484	SMT-8-PS-S-LED-24-B
N/C contact						
	Insertable in the slot from above, flush with cylinder profile	PNP	Cable, 3-wire	7.5	543 873	SMT-8-M-PO-24V-K7,5-OE

Ordering data – Proximity sensors for T-slot, magnetic reed					Technical data → Internet: sme	
	Type of mounting	Switch output	Electrical connection	Cable length [m]	Part No.	Type
N/O contact						
	Insertable in the slot lengthwise, flush with the cylinder profile	Contacting	Cable, 3-wire	2.5	150 855	SME-8-K-LED-24
			Plug M8x1, 3-pin	0.3	150 857	SME-8-S-LED-24
N/C contact						
	Insertable in the slot lengthwise, flush with the cylinder profile	Contacting	Cable, 3-wire	7.5	160 251	SME-8-O-K-LED-24

Ordering data – Connecting cables				Technical data → Internet: nebu	
	Electrical connection, left	Electrical connection, right	Cable length [m]	Part No.	Type
	Straight socket, M8x1, 3-pin	Cable, open end, 3-wire	2.5	541 333	NEBU-M8G3-K-2.5-LE3
			5	541 334	NEBU-M8G3-K-5-LE3
	Angled socket, M8x1, 3-pin	Cable, open end, 3-wire	2.5	541 338	NEBU-M8W3-K-2.5-LE3
			5	541 341	NEBU-M8W3-K-5-LE3

Swivel modules DSMI-B, integrated angular displacement encoder

Key features

Individual components for positioning with axis controller CPX-CMAX or end-position controller CPX-CMPX

Axis controller/
End-position controller
CPX-CMAX/
CPX-CMPX



Proportional
directional control valve
VPWP



Sensor interface
CASM-S-D2-R3



Swivel module
DSMI



Individual components for positioning with axis controller SPC200 or end-position controller SPC11

Axis controller
SPC200



Proportional
directional control valve
MPYE



Axis interface
SPC-AIF-POT-LWG



Swivel module
DSMI



End-position controller
SPC11



Proportional
directional control valve
MPYE



Swivel module
DSMI



Swivel modules DSMI-B, integrated angular displacement encoder

Key features

At a glance

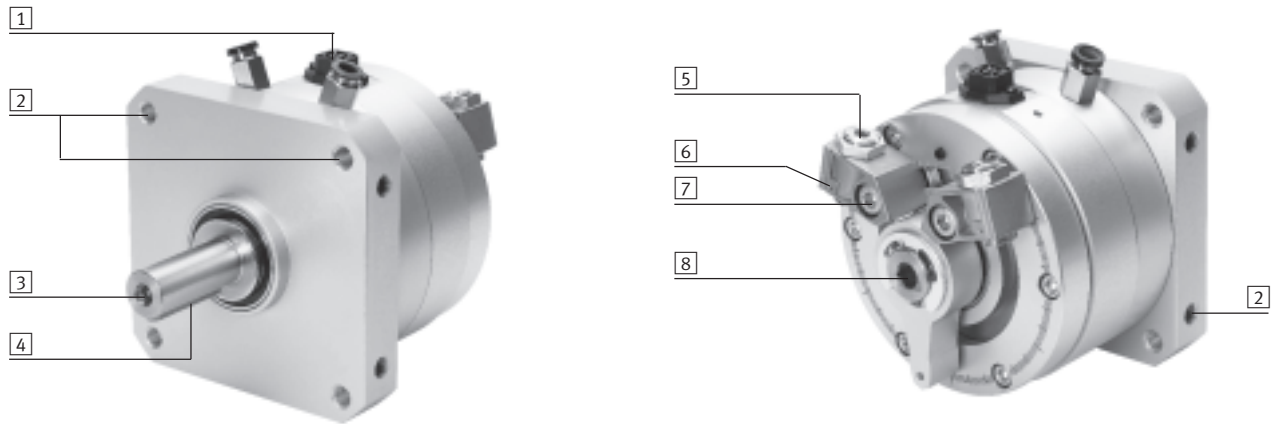

- | | | | |
|--|--|---|---|
| <ul style="list-style-type: none"> 1 Connector plug for displacement encoder 2 Wide range of integrated mounting options 3 Option for mounting on the drive shaft by the user | <ul style="list-style-type: none"> 4 Woodruff key 5 Fixed stop with precision adjustment of the swivel angle 6 Bracket for mounting proximity sensor for contactless position sensing | <ul style="list-style-type: none"> 7 Fixed stop can be set at any point within the swivel angle 8 Manual operation via internal hexagon socket in the drive shaft | <p>A female thread is already integrated for attachment of an additional drive shaft by the user.</p> |
|--|--|---|---|

Mounting options

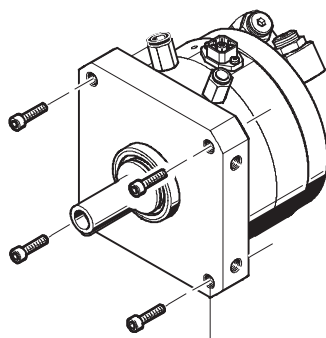

Threaded through-hole

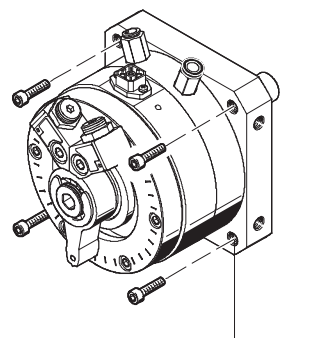

Threaded through-hole

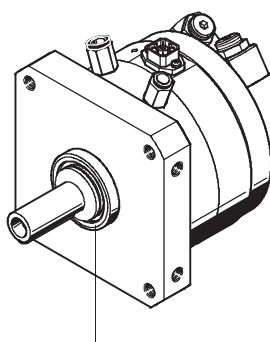

Centring collar

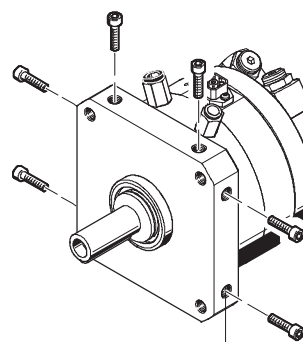

Basic thread

Swivel modules DSMI-B, integrated angular displacement encoder

Peripherals overview

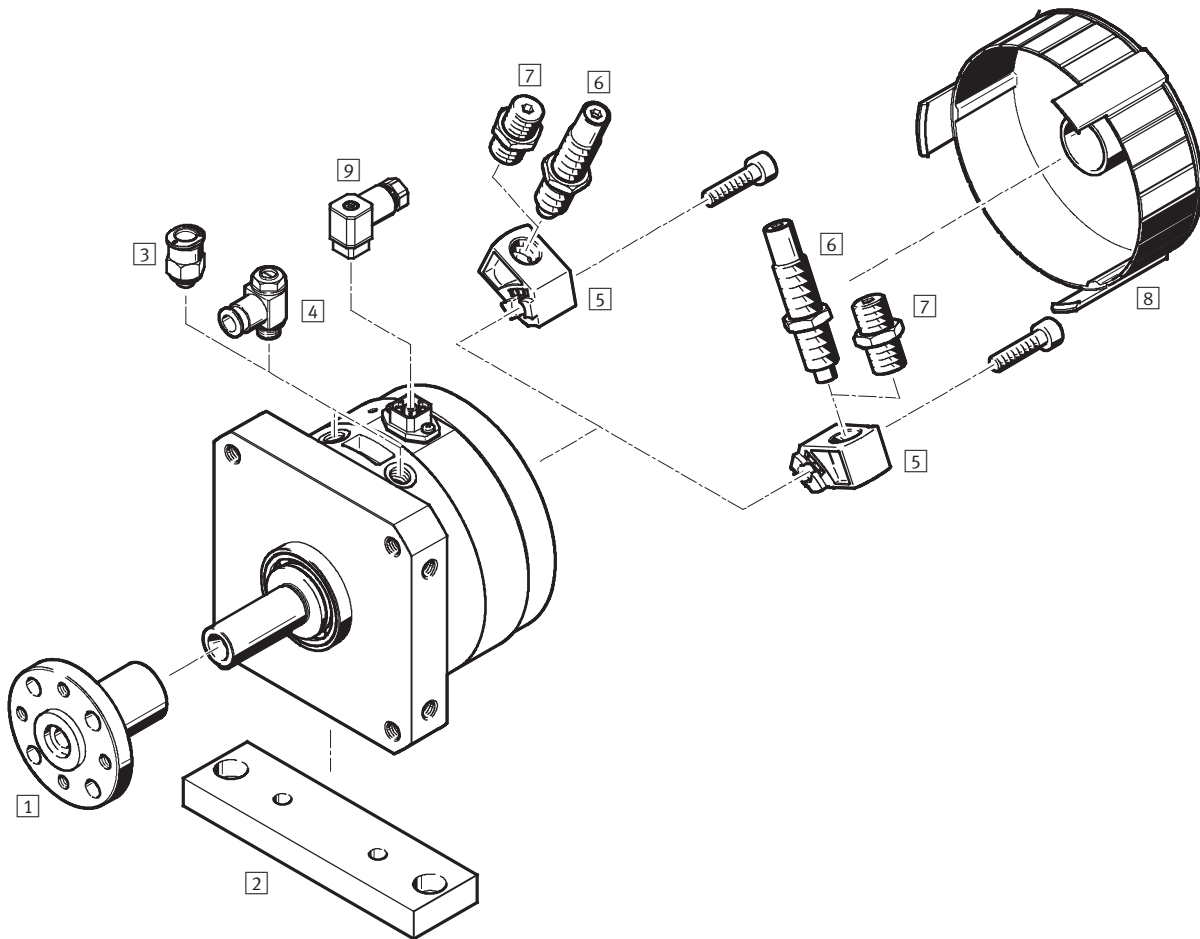

Accessories			
	For size	Brief description	→ Page/Internet
1	25, 40	Push-on flange FWSR For mounting attachments	131
2	25, 40	Mounting plate HSM Adapter plate for mounting the drive	131
3	25, 40, 63	Push-in fitting QS For connecting compressed air tubing with standard O.D. (push-in fittings are included in the scope of delivery of the drive)	quick star
4	25, 40, 63	One-way flow control valve GRLA For regulating speed (is recommended when using the DSMI as a measuring cylinder)	132
5	25, 40, 63	Cushioning mount DSM-B <ul style="list-style-type: none"> For elastic cushioning components For shock absorbers As a mechanical stop in Soft Stop applications 	132
6	25, 40, 63	Shock absorber DYSC Self-adjusting shock absorbers with fixed stop (is recommended when using the DSMI as a measuring cylinder)	132
7	25, 40, 63	Cushioning kit DSM...-P-B Elastic cushioning components with fixed stop	132
8	25, 40	Cover cap AKM Reduces the risk of injury in the swivel range of the stop lever	132
9	25, 40, 63	Plug socket SD For connecting the displacement encoder	132

Swivel modules DSMI-B, integrated angular displacement encoder

Type codes

	DSMI	-		-	270	-	A	-	B
Type									
Double-acting									
DSMI	Swivel module with angular displacement encoder								
Size									
Max. swivel angle [°]									
Position sensing									
A	Via proximity sensor								
Variant									
B	B series								

Swivel modules DSMI-B, integrated angular displacement encoder

FESTO

Technical data

-N- Size
25 ... 63
Width
5 ... 40 Nm



General technical data			
Size	25	40	63
Design	Rotary vane Drive shaft, running in ball bearings		
Mode of operation	Double-acting		
Position sensing	Via integrated angular displacement encoder Via proximity sensor ¹⁾		
Measuring principle (angular displacement encoder)	Analogue with conductive plastic potentiometer		
Type of mounting	Via female thread		
Min. travel speed [°/s]	50		
Max. travel speed [°/s]	2,000		
Max. swivel angle ²⁾ [°]	272		
Adjustment range of swivel angle [°]	0 ... 270		
Pneumatic connection	M5	G ¹ / ₈	G ¹ / ₄
Push-in fitting used	QSM-M5-6	QS-G ¹ / ₈ -8-I	QS-G ¹ / ₄ -10-I
Compressed air tubing O.D. [mm]	6	8	10
Electrical connection	4-pin plug, □ 16, DIN 45 322		

- 1) Can be ordered as an option
2) Note stroke reduction in combination with axis controllers CPX-CMAX, SPC200

Torque [Nm]			
Size	25	40	63
Torque ¹⁾	5	20	40

- 1) Theoretical values, calculated at 6 bar

Permissible forces on the drive shaft			
Size	25	40	63
Max. radial force [N]	120	350	500
Max. axial force [N]	50	120	500
Max. swivel frequency ¹⁾ [Hz]	2		1

- 1) At max. permissible mass moment of inertia, operating pressure of 6 bar and a swivel angle of 270°

Note

Further technical data
→ Internet: dsm

Swivel modules DSMI-B, integrated angular displacement encoder

Technical data

Positioning characteristics with axis controller CPX-CMAX, SPC200				
Size		25	40	63
Repetition accuracy	[°]	±0.3		
Mounting position		Any		
Min. mass moment of inertia, horizontal ¹⁾	[kgm ²]	15 x 10 ⁻⁴	60 x 10 ⁻⁴	300 x 10 ⁻⁴
Max. mass moment of inertia, horizontal ¹⁾	[kgm ²]	300 x 10 ⁻⁴	1,200 x 10 ⁻⁴	6,000 x 10 ⁻⁴
Min. mass moment of inertia, vertical ²⁾	[kgm ²]	15 x 10 ⁻⁴	60 x 10 ⁻⁴	300 x 10 ⁻⁴
Max. mass moment of inertia, vertical ²⁾	[kgm ²]	300 x 10 ⁻⁴	1,200 x 10 ⁻⁴	6,000 x 10 ⁻⁴
Min. travel speed	[°/s]	50		
Max. travel speed	[°/s]	2,000		
Typ. positioning time, long stroke ³⁾	[s]	0.35/0.60	0.30/0.55	0.64/1
Typ. positioning time, short stroke ⁴⁾	[s]	0.15/0.25	0.25/0.25	0.30/0.35
Minimum positioning stroke	[°]	5		
Max. swivel stroke ⁵⁾	[°]	260		
Recommended proportional directional control valve				
For CPX-CMAX		On request	VPWP-4-L-5-Q8-10-E-F	
For SPC200		MPYE-5-M5-010-B	MPYE-5-1/8-LF-010-B	

- 1) Must not change during the movement, but may be outside the centre of gravity
- 2) Must not change during the movement, must act at the centre of gravity
- 3) At 6 bar, vertical mounting position, 260° positioning angle at min./max. mass moment of inertia
- 4) At 6 bar, vertical mounting position, 15° positioning angle at min./max. mass moment of inertia
- 5) A stroke reduction of 5° on both sides must be noted

Positioning characteristics with Soft Stop end-position controller CPX-CMPX, SPC11				
Size		25	40	63
End-position repetition accuracy ¹⁾	[°]	< 0.2		
Intermediate-position repetition accuracy	[°]	±2		
Mounting position		Horizontal		
Cushioning ²⁾		Electronically controlled		
Min. mass moment of inertia, horizontal ³⁾	[kgm ²]	15 x 10 ⁻⁴	60 x 10 ⁻⁴	300 x 10 ⁻⁴
Max. mass moment of inertia, horizontal ³⁾	[kgm ²]	300 x 10 ⁻⁴	1,200 x 10 ⁻⁴	6,000 x 10 ⁻⁴
Minimum swivel stroke	[°]	15		
Recommended proportional directional control valve				
For CPX-CMPX		On request	VPWP-4-L-5-Q8-10-E-F	
For SPC200		MPYE-5-M5-010-B	MPYE-5-1/8-LF-010-B	

- 1) When using the DSMI stops
- 2) The cushioning pad on the stop lever must be removed for applications with Soft Stop. The stop lever must not swivel to the end stop at too great a speed as this could damage the swivel module
- 3) Must not change during the movement, but may be outside the centre of gravity

Operating and environmental conditions	
Operating medium	Compressed air, filtered and unlubricated, filter unit 5 µm
Operating pressure	[bar] 2 ... 10
Operating pressure ¹⁾	[bar] 4 ... 8
Ambient temperature ²⁾	[°C] -10 ... +60
Vibration resistance	To DIN/IEC 68 Part 2 – 6, severity level 2
Shock resistance	To DIN/IEC 68 Part 2 – 82, severity level 2
CE mark (see declaration of conformity)	To EU EMC Directive
Protection class	IP65 to IEC 60 529
Corrosion resistance class CRC ³⁾	1

- 1) Only applies to applications with end-position controller CPX-CMPX, SPC11 and axis controller CPX-CMAX, SPC200
- 2) Note operating range of proximity sensors
- 3) Corrosion resistance class 1 to Festo standard 940 070. Components subject to low corrosion stress. Transport and storage protection

Swivel modules DSMI-B, integrated angular displacement encoder

FESTO

Technical data

Weight				
Size		25	40	63
DSMI	[g]	1,080	3,950	6,900

Electrical data, displacement encoder			
Power supply ¹⁾	[V DC]	10	
Max. current consumption	[mA]	4	
Wiper current	Recommended	[µA]	< 1
	Maximum ²⁾	[mA]	10
Connection resistance	[kΩ]	5	
Connection resistance tolerance	[%]	±20	
Angular resolution	[°]	0.1	
Independent linearity	[%]	0.25	
Output signal		Analogue	

- 1) Stabilised power supply is recommended, max. 42 V DC permissible.
2) Only permissible in the short term in the event of a fault.

Materials

Sectional view

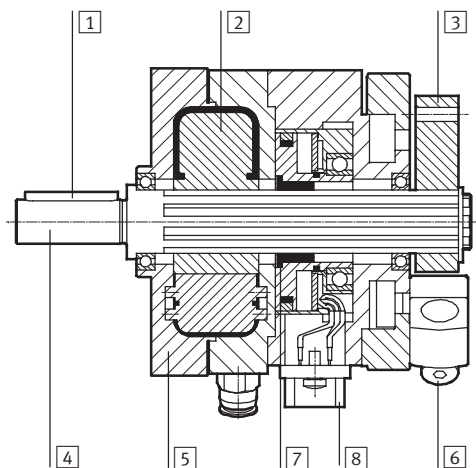

Cylinder/displacement encoder		
Cylinder		
1	Woodruff key	Steel
2	Rotary vane	Glass fibre-reinforced plastic
3	Stop lever	Anodised wrought aluminium alloy
4	Drive shaft	Nickel-plated steel
5	Housing	Anodised wrought aluminium alloy
6	Fixed stop/screw	Steel
	Note on materials	Free of copper, PTFE and silicone
Displacement encoder		
7	Coupling	Polyurethane
8	Housing	Anodised aluminium

Swivel modules DSMI-B, integrated angular displacement encoder

FESTO

Accessories

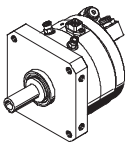
Ordering data		Size	Swivel angle [°]	Part No.	Type
	25	270		561690	DSMI-25-270-A-B
	40			561691	DSMI-40-270-A-B
	63			1202485	DSMI-63-270-A-B

Accessories

Push-on flange FWSR

Materials:
Anodised aluminium
Free of copper, PTFE and silicone

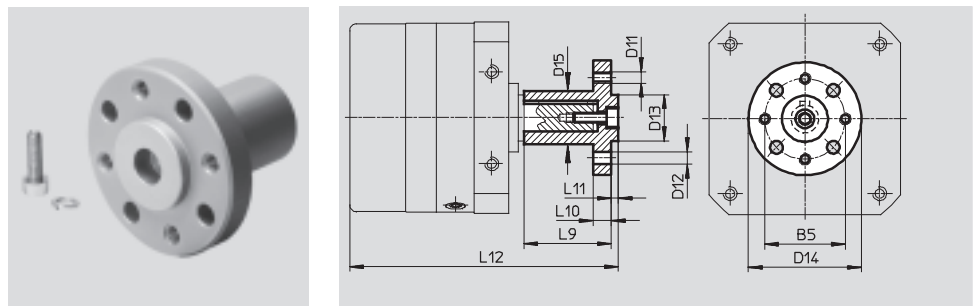

Dimensions and ordering data													
For size	B5	D11	D12 ∅	D13 ∅	D14 ∅	D15 ∅	L9	L10	L11	L12	Weight [g]	Part No.	Type
25	35	M5	5.5	20	50	23	38	8	3	116.5	68	13240	FWSR-25
40	54	M8	9	36	70	38	60	11	5	186.5	240	14656	FWSR-40

Mounting plate HSM

Materials:
Anodised aluminium
Free of copper, PTFE and silicone

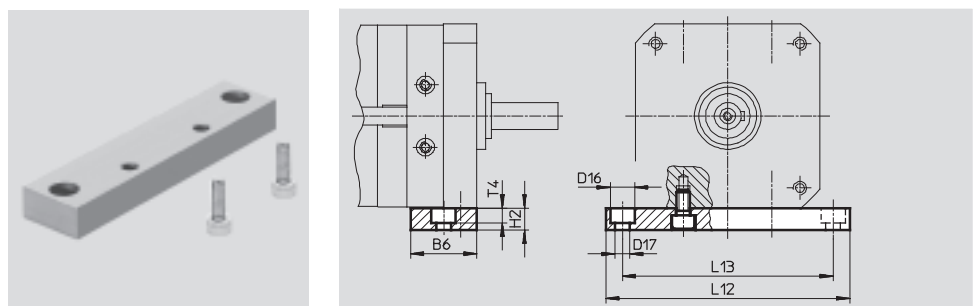

Dimensions and ordering data										
For size	B6	D16 ∅	D17 ∅	H2	L12	L13	T4	Weight [g]	Part No.	Type
25	30	11	6.6	10	110	95	6.8	94	165573	HSM-25
40	45	18	11	20	180	155	11	459	165575	HSM-40

Swivel modules DSMI-B, integrated angular displacement encoder

Accessories

Cover cap AKM

Materials:
Polyamide

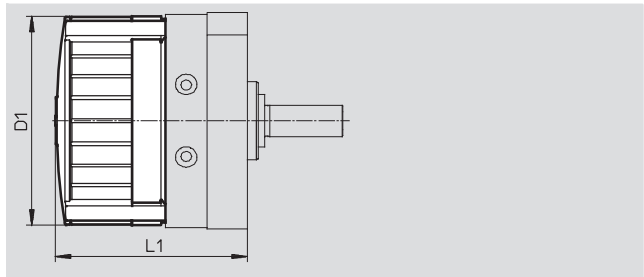

Dimensions and ordering data				
For size [mm]	D1 ∅	L1	Part No.	Type
25	83	98.5±1.2	549196	AKM-25
40	130	135.5±1.5	549198	AKM-40

Ordering data					
	For size	Brief description	Part No.	Type	PU ¹⁾
Cushioning mount					
	25	<ul style="list-style-type: none"> For elastic cushioning components For shock absorbers 	547902	DSM-25-B	2
	40		547904	DSM-40-B	
	63		552085	DSM-63-B	
Cushioning kit					
	25	For cushioning mount DSMI-...-B	550658	DSM-16/25-P-B	2
	40		550660	DSM-40-P-B	
	63		552086	DSM-63-P-B	
Shock absorber					
	25	For cushioning mount DSMI-...-B	548012	DYSC-7-5-Y1F	1
	40		548014	DYSC-12-12-Y1F	
	63		553593	DYSC-16-18-Y1F	

1) Packaging unit

Ordering data – One-way flow control valves					Technical data → Internet: grla	
	For size	Connection		Material	Part No.	Type
		Thread	For tubing O.D.			
For exhaust air						
	25	M5	3	Metal design	193137	GRLA-M5-QS-3-D
			4		193138	GRLA-M5-QS-4-D
			6		193139	GRLA-M5-QS-6-D
	40	G ³ / ₈	3		193142	GRLA- ³ / ₈ -QS-3-D
			4		193143	GRLA- ³ / ₈ -QS-4-D
			6		193144	GRLA- ³ / ₈ -QS-6-D
			8		193145	GRLA- ³ / ₈ -QS-8-D
	63	G ¹ / ₄	10		193148	GRLA- ¹ / ₄ -QS-10-D

Ordering data – Plug sockets					
	Pin	Pin allocation	Designation	Part No.	Type
	1	Power supply	Plug socket	194332	SD-4-WD-7
	2	Signal			
	3	0 V			
	4	PE (yellow), screened			

Product Range and Company Overview

A Complete Suite of Automation Services

Our experienced engineers provide complete support at every stage of your development process, including: conceptualization, analysis, engineering, design, assembly, documentation, validation, and production.



Custom Automation Components
Complete custom engineered solutions



Custom Control Cabinets
Comprehensive engineering support and on-site services



Complete Systems
Shipment, stocking and storage services

The Broadest Range of Automation Components

With a comprehensive line of more than 30,000 automation components, Festo is capable of solving the most complex automation requirements.



Electromechanical
Electromechanical actuators, motors, controllers & drives



Pneumatics
Pneumatic linear and rotary actuators, valves, and air supply



PLCs and I/O Devices
PLC's, operator interfaces, sensors and I/O devices

Supporting Advanced Automation... As No One Else Can!

Festo is a leading global manufacturer of pneumatic and electromechanical systems, components and controls for industrial automation, with more than 12,000 employees in 56 national headquarters serving more than 180 countries. For more than 80 years, Festo has continuously elevated the state of manufacturing with innovations and optimized motion control solutions that deliver higher performing, more profitable automated manufacturing and processing equipment. Our dedication to the advancement of automation extends beyond technology to the education and development of current and future automation and robotics designers with simulation tools, teaching programs, and on-site services.

Quality Assurance, ISO 9001 and ISO 14001 Certifications

Festo Corporation is committed to supply all Festo products and services that will meet or exceed our customers' requirements in product quality, delivery, customer service and satisfaction.

To meet this commitment, we strive to ensure a consistent, integrated, and systematic approach to management that will meet or exceed the requirements of the ISO 9001 standard for Quality Management and the ISO 14001 standard for Environmental Management.



© Copyright 2008, Festo Corporation. While every effort is made to ensure that all dimensions and specifications are correct, Festo cannot guarantee that publications are completely free of any error, in particular typing or printing errors. Accordingly, Festo cannot be held responsible for the same. For Liability and Warranty conditions, refer to our "Terms and Conditions of Sale", available from your local Festo office. All rights reserved. No part of this publication may be reproduced, distributed, or transmitted in any form or by any means, electronic, mechanical, photocopying or otherwise, without the prior written permission of Festo. All technical data subject to change according to technical update.



Printed on recycled paper at New Horizon Graphic, Inc., FSC certified as an environmentally friendly printing plant.

Festo North America

Festo Regional Contact Center

5300 Explorer Drive
Mississauga, Ontario L4W 5G4
Canada

USA Customers:

For ordering assistance,

Call: 1.800.99.FESTO (1.800.993.3786)

Fax: 1.800.96.FESTO (1.800.963.3786)

Email: customer.service@us.festo.com

For technical support,

Call: 1.866.GO.FESTO (1.866.463.3786)

Fax: 1.800.96.FESTO (1.800.963.3786)

Email: product.support@us.festo.com

Canadian Customers:

Call: 1.877.GO.FESTO (1.877.463.3786)

Fax: 1.877.FX.FESTO (1.877.393.3786)

Email: festo.canada@ca.festo.com

USA Headquarters

Festo Corporation
395 Moreland Road
P.O. Box 18023
Hauppauge, NY 11788, USA
www.festo.com/us

USA Sales Offices

Appleton

North 922 Tower View Drive, Suite N
Greenville, WI 54942, USA

Boston

120 Presidential Way, Suite 330
Woburn, MA 01801, USA

Chicago

1441 East Business Center Drive
Mt. Prospect, IL 60056, USA

Dallas

1825 Lakeway Drive, Suite 600
Lewisville, TX 75057, USA

Detroit – Automotive Engineering Center

2601 Cambridge Court, Suite 320
Auburn Hills, MI 48326, USA

New York

395 Moreland Road
Hauppauge, NY 11788, USA

Silicon Valley

4935 Southfront Road, Suite F
Livermore, CA 94550, USA

United States



USA Headquarters, East: Festo Corp., 395 Moreland Road, Hauppauge, NY 11788

Phone: 1.631.435.0800; Fax: 1.631.435.8026;

Email: info@festo-usa.com

www.festo.com/us

Canada



Headquarters: Festo Inc., 5300 Explorer Drive, Mississauga, Ontario L4W 5G4

Phone: 1.905.624.9000; Fax: 1.905.624.9001;

Email: festo.canada@ca.festo.com

www.festo.ca

Mexico



Headquarters: Festo Pneumatic, S.A., Av. Ceylán 3, Col. Tequesquahuac,
54020 Tlalneantla, Edo. de México

Phone: 011 52 [55] 53 21 66 00; Fax: 011 52 [55] 53 21 66 65;

Email: festo.mexico@mx.festo.com

www.festo.com/mx

Central USA

Festo Corporation
1441 East Business
Center Drive
Mt. Prospect, IL 60056, USA
Phone: 1.847.759.2600
Fax: 1.847.768.9480



Western USA

Festo Corporation
4935 Southfront Road,
Suite F
Livermore, CA 94550, USA
Phone: 1.925.371.1099
Fax: 1.925.245.1286



Festo Worldwide

Argentina Australia Austria Belarus Belgium Brazil Bulgaria Canada Chile China Colombia Croatia Czech Republic Denmark
Estonia Finland France Germany Great Britain Greece Hong Kong Hungary India Indonesia Iran Ireland Israel Italy Japan Latvia
Lithuania Malaysia Mexico Netherlands New Zealand Norway Peru Philippines Poland Romania Russia Serbia Singapore
Slovakia Slovenia South Africa South Korea Spain Sweden Switzerland Taiwan Thailand Turkey Ukraine United States Venezuela

www.festo.com