

Accessories for electrical positioning systems

FESTO



Accessories for electrical positioning systems

Key features

FESTO

At a glance

Bellows couplings EAMC

→ 4



- One-piece couplings are suitable for force-locked and backlash-free transmission of small and medium torques between electric motors and axes
- System product for positioning technology
- Outside diameter 15 and 19 mm

Gear couplings EAMC

→ 6



- Three-piece couplings are suitable for force-locked and backlash-free transmission of high torques between electric motors and axes
- System product for positioning technology
- Outside diameter 15, 16, 20, 30, 40, 42, 56, 65 mm

Gear couplings EAMD, with expanding mandrel

→ 10



- Three-piece couplings are suitable for force-locked and backlash-free transmission of high torques between electric motors and axes
- System product for positioning technology
- Outside diameter 16, 19, 25, 32, 42, 56, 67 mm

Connecting shafts KSK

→ 13



Electric axes are often combined to form multi-axis systems. It is particularly important when designing gantry systems with a long gantry axis and

heavy loads that the two basic axes be driven synchronously. For these systems, two axes with toothed belt

drive are generally coupled with a shared motor and synchronised using a connecting shaft.

Range of applications:

- For synchronising toothed belt axes DGE and EGC
- For torsion-resistant transmission of the necessary torque
- For slip-free transmission of an identical feed speed
- For compensating tolerances and alignment errors between two axes

Technical data for toothed belt axis:
DGE-ZR-KF → 14
EGC-TB-KF → 16

Accessories for electrical positioning systems

Key features

FESTO

Application example

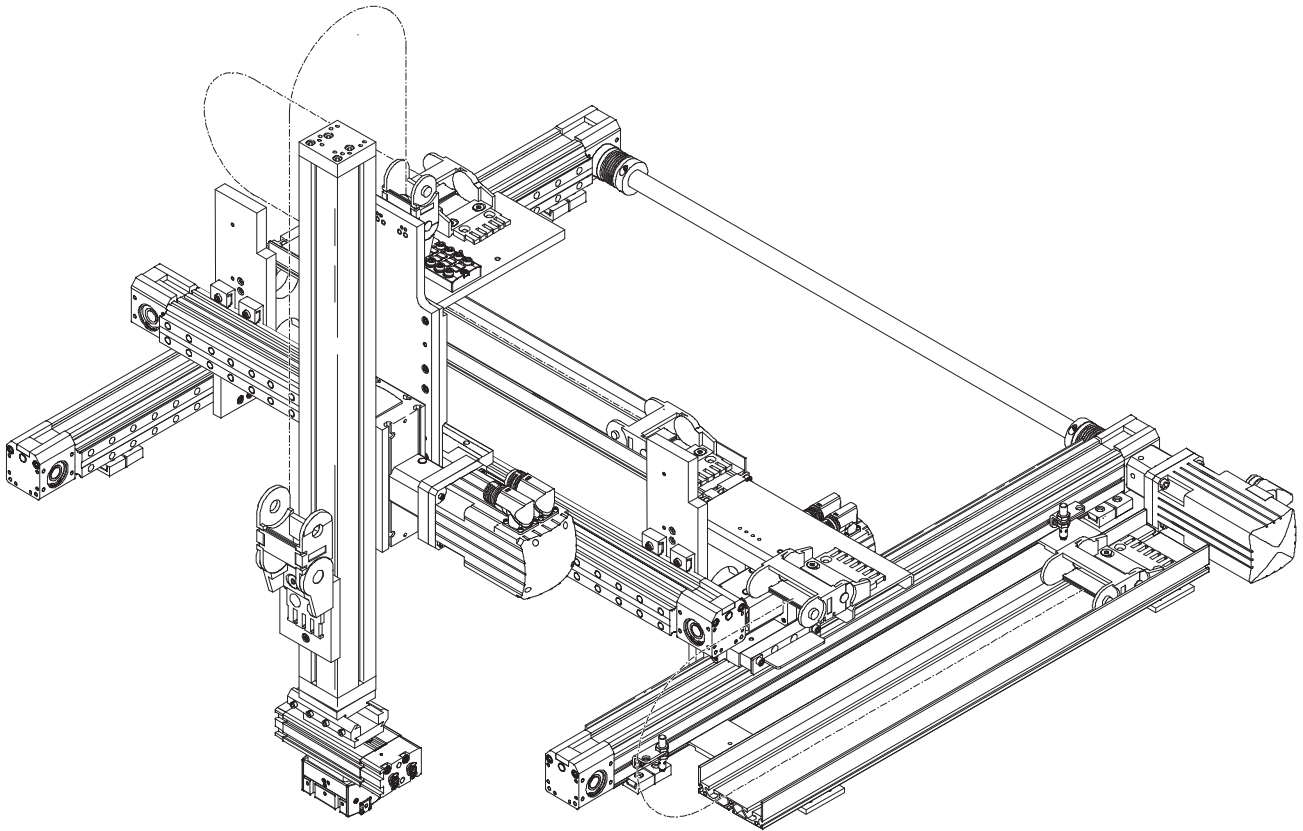

Couplings EAMC

Type codes

Bellows couplings EAMC

Type codes

		EAMC	-	19	-	24	-	6	-	9
Type										
EAMC	Bellows coupling									
Outside diameter [mm]										
15	∅ 15 mm									
19	∅ 19 mm									
Overall length										
22	22 mm									
24	24 mm									
Clamping diameter D1										
Clamping diameter D2										

Couplings EAMC

Technical data

Bellows coupling EAMC

∅ - Diameter
15 and 19 mm



General technical data		EAMC-15	EAMC-19
Type			
Mass moment of inertia	[kg mm ²]	0.13	0.47
Tightening torque of clamping screw	[Nm]	1.5	1.5
Max. rotational speed	[1/min]	12,000	8,000
Corrosion resistance class CRC ¹⁾		1	
Materials	Hubs	Aluminium	
	Bellows	Stainless steel	
Note on materials		RoHS-compliant	

1) Corrosion resistance class 1 as per Festo standard 940 070
Components subject to low corrosion stress. Transport and storage protection. Parts that do not have primarily decorative surface requirements, e.g. in internal areas that are not visible or behind covers.

Dimensions and ordering data Download CAD data → www.festo.com

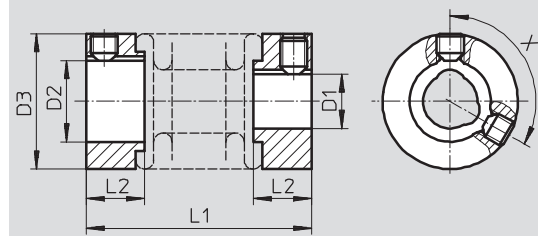

∅ [mm]	D1 ∅ H7	D2 ∅ H7	D3 ∅	L1	L2	X [°]	Transferable torque [Nm]	Weight [g]	Part No.	Type
15	4	5	15	22	6.5	–	1	6	530084	EAMC-15-22-4-5
	4	6	15	22	6.5	–	1	6	540750	EAMC-15-22-4-6
	4	9	15	22	6.5	–	1	6	184262	EAMC-15-22-4-9
	5	5	15	22	6.5	–	1	6	530085	EAMC-15-22-5-5
	5	6	15	22	6.5	–	1	6	540751	EAMC-15-22-5-6
	5	9	15	22	6.5	–	1	6	529953	EAMC-15-22-5-9
19	6	6.35	19	24	7.5	120	1.5	12	530086	EAMC-19-24-6-6.35
	6	6	19	24	7.5	120	1.5	12	184265	EAMC-19-24-6-6
	6	9	19	24	7.5	120	1.5	12	184263	EAMC-19-24-6-9

Couplings EAMC

Type codes

Gear couplings EAMC

Type codes

EAMC - 42 - 50 - 14 - 20

Type	
EAMC	Gear coupling

Outside diameter [mm]	
15	∅ 15 mm
16	∅ 16 mm
20	∅ 20 mm
30	∅ 30 mm
40	∅ 40 mm
42	∅ 42 mm
56	∅ 56 mm
65	∅ 65 mm

Overall length	
20	20 mm
30	30 mm
32	32 mm
35	35 mm
50	50 mm
58	58 mm
66	66 mm
90	90 mm

Clamping diameter D1	

Clamping diameter D2	

Couplings EAMC

Technical data

FESTO

Gear coupling EAMC

⌀ - Diameter
15 ... 65 mm



General technical data		EAMC-15-20	EAMC-16-20	EAMC-20-30	EAMC-30-32	EAMC-30-35
Type						
Mass moment of inertia	[kg mm ²]	0.23	0.3	1.06	5.87	6.1
Tightening torque of clamping screw	[Nm]	1.3	0.6	0.76	4	2.9
Max. rotational speed	[1/min]	10,000	10,000	19,000	8,000	8,000
Corrosion resistance class CRC ¹⁾		1				
Materials	Hubs	Aluminium				
	Ring gear	Polyurethane				
Note on materials		RoHS-compliant				

Type		EAMC-40-66	EAMC-42-50	EAMC-42-66	EAMC-56-58	EAMC-65-90
Mass moment of inertia	[kg mm ²]	42.3	35	45.5	127	417
Tightening torque of clamping screw	[Nm]	10.5	8	8	15	25
Max. rotational speed	[1/min]	6,500	6,000	6,000	5,500	4,500
Corrosion resistance class CRC ¹⁾		1				
Materials	Hubs	Aluminium				
	Ring gear	Polyurethane				
Note on materials		RoHS-compliant				

1) Corrosion resistance class 1 as per Festo standard 940 070
Components subject to low corrosion stress. Transport and storage protection. Parts that do not have primarily decorative surface requirements, e.g. in internal areas that are not visible or behind covers.

Couplings EAMC

Technical data

FESTO

Dimensions and ordering data

Download CAD data → www.festo.com

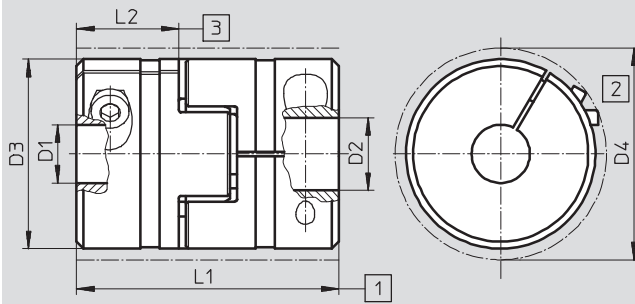

- 1 Nominal length with axial offset compensation
- 2 Min. installation \varnothing (interference profile of clamping screw)
- 3 Insertion depth

\varnothing [mm]	D1 \varnothing H7	D2 \varnothing H7	D3 \varnothing	D4 \varnothing	L1	L2	Transferable torque [Nm]	Weight [g]	Part No.	Type
15	5	6	15	-	20	6.5	1.5	8	533707	EAMC-15-20-5-6
16	4	5	16	17	20	6	0.7	8	562674	EAMC-16-20-4-5
	4	6	16	17	20	6	0.7	8	562673	EAMC-16-20-4-6
	5	5	16	17	20	6	1.1	8	562676	EAMC-16-20-5-5
	5	6	16	17	20	6	1.1	8	543419	EAMC-16-20-5-6
	5	8	16	17	20	6	1.1	8	562677	EAMC-16-20-5-8
	6	6	16	17	20	6	1.6	8	543420	EAMC-16-20-6-6
20	5	6	20	24	30	10	2.2	20	558902	EAMC-20-30-5-6
	6	6	20	24	30	10	2.3	20	558901	EAMC-20-30-6-6
30	5	6	30	-	32	10	3.5	48	561333	EAMC-30-32-5-6
	5	8	30	-	32	10	3.5	48	562678	EAMC-30-32-5-8
	6	6	30	-	32	10	6.5	48	558312	EAMC-30-32-6-6
	6	8	30	-	32	10	6.5	48	533708	EAMC-30-32-6-8
	6.35	8	30	-	32	10	6.5	48	543421	EAMC-30-32-6.35-8
	6	6.35	30	-	32	10	6.5	48	551002	EAMC-30-32-6-6.35
	6	9	30	-	32	10	6.5	48	551003	EAMC-30-32-6-9
	6.35	9	30	-	32	10	6.5	48	562679	EAMC-30-32-6.35-10
	8	8	30	-	32	10	12.5	48	543422	EAMC-30-32-8-8
	8	9	30	-	32	10	12.5	48	543423	EAMC-30-32-8-9
	8	10	30	-	32	10	12.5	48	558029	EAMC-30-32-8-10
	8	11	30	-	32	10	12.5	48	551004	EAMC-30-32-8-11
	9	10	30	-	32	10	12.5	48	562680	EAMC-30-32-9-10
	10	11	30	-	32	10	12.5	48	565008	EAMC-30-32-10-11
	6	6	30	31.4	35	11	7.5	45	123040	EAMC-30-35-6-6
	6	6.35	30	31.4	35	11	7.5	45	530087	EAMC-30-35-6-6.35
	6.35	8	30	31.4	35	11	7.5	45	530088	EAMC-30-35-6.35-8
	6.35	12	30	31.4	35	11	7.5	45	550995	EAMC-30-35-6.35-12
	6	8	30	31.4	35	11	7.5	45	123041	EAMC-30-35-6-8
	6	9	30	31.4	35	11	7.5	45	530941	EAMC-30-35-6-9
	6	11	30	31.4	35	11	7.5	45	123843	EAMC-30-35-6-11
	6	12	30	31.4	35	11	7.5	45	123855	EAMC-30-35-6-12
	8	8	30	31.4	35	11	8	45	123044	EAMC-30-35-8-8
	8	9	30	31.4	35	11	8	45	557390	EAMC-30-35-8-9
	8	10	30	31.4	35	11	8	45	123050	EAMC-30-35-8-10
	8	11	30	31.4	35	11	8	45	123042	EAMC-30-35-8-11
	8	12	30	31.4	35	11	8	45	123043	EAMC-30-35-8-12
9	12	30	31.4	35	11	8.3	45	550996	EAMC-30-35-9-12	
10	12	30	31.4	35	11	8.6	45	552640	EAMC-30-35-10-12	
11	12	30	31.4	35	11	8.9	45	123051	EAMC-30-35-11-12	
12	12	30	31.4	35	11	9.4	45	123052	EAMC-30-35-12-12	

Couplings EAMC

Technical data

FESTO

∅ [mm]	D1 ∅ H7	D2 ∅ H7	D3 ∅	D4 ∅	L1	L2	Transferable torque [Nm]	Weight [g]	Part No.	Type
40	11	11	40	45.7	66	25	17	139	530090	EAMC-40-66-11-11
	11	12	40	45.7	66	25	17	139	525864	EAMC-40-66-11-12
	11	15	40	45.7	66	25	17	139	550998	EAMC-40-66-11-15
	11	20	40	45.7	66	25	17	139	550999	EAMC-40-66-11-20
	12	15	40	45.7	66	25	17	139	123850	EAMC-40-66-12-15
	12	19	40	45.7	66	25	17	139	529952	EAMC-40-66-12-19
	12	20	40	45.7	66	25	17	139	123851	EAMC-40-66-12-20
	15	16	40	45.7	66	25	17	139	123846	EAMC-40-66-15-16
	15	19	40	45.7	66	25	17	139	123844	EAMC-40-66-15-19
	15	20	40	45.7	66	25	17	139	123845	EAMC-40-66-15-20
	15	24	40	45.7	66	25	17	139	176033	EAMC-40-66-15-24
	19	20	40	45.7	66	25	17	139	123847	EAMC-40-66-19-20
	20	20	40	45.7	66	25	17	139	123849	EAMC-40-66-20-20
	20	24	40	45.7	66	25	17	139	176034	EAMC-40-66-20-24
XX ¹⁾	15	40	45.7	66	25	-	139	176036	EAMC-40-66-XX-15	
XX ¹⁾	20	40	45.7	66	25	-	139	176037	EAMC-40-66-XX-20	
42	11	12	42	44.5	50	17	17	138	543424	EAMC-42-50-11-12
	12	12	42	44.5	50	17	17	138	533709	EAMC-42-50-12-12
	12	19	42	44.5	50	17	17	138	551005	EAMC-42-50-12-19
	12	24	42	44.5	50	17	17	138	558314	EAMC-42-50-12-24
	14	20	42	44.5	50	17	17	138	533710	EAMC-42-50-14-20
	11	12	42	44.5	66	25	17	166	558313	EAMC-42-66-11-12
56	19	25	56	57	58	20	60	275	558315	EAMC-56-58-19-25
	24	25	56	57	58	20	60	265	558316	EAMC-56-58-24-25
65	15	24	65	72.6	90	35	80	535	530940	EAMC-65-90-15-24
	19	25	65	72.6	90	35	85	535	551000	EAMC-65-90-19-25
	20	25	65	72.6	90	35	85	535	176035	EAMC-65-90-20-25
	24	25	65	72.6	90	35	92	535	123852	EAMC-65-90-24-25
	25	25	65	72.6	90	35	92	535	123853	EAMC-65-90-25-25
	25	40	65	72.6	90	35	62	535	551001	EAMC-65-90-25-40
	XX ²⁾	25	65	72.6	90	35	-	535	176038	EAMC-65-90-XX-25

1) Hubs predrilled to ∅ 5 mm. Hole max. 20 mm

2) Hubs predrilled to ∅ 9.5 mm. Hole max. 38 mm

Couplings EAMD

Type codes

Gear couplings EAMD, with expanding mandrel

Type codes

EAMD - 25 - 22 - 6.35 - 10 x 12

Type	
EAMD	Gear coupling with expanding mandrel

Outside diameter [mm]	
16	∅ 16 mm
19	∅ 19 mm
25	∅ 25 mm
32	∅ 32 mm
42	∅ 42 mm
56	∅ 56 mm
67	∅ 67 mm

Overall length	
15	15 mm
22	22 mm
32	32 mm
40	40 mm
46	46 mm
51	51 mm
82	82 mm

Clamping diameter D1

Mandrel diameter D2

Mandrel length C2

Couplings EAMD

Technical data

Gear coupling EAMD, with expanding mandrel

∅ - Diameter
16 ... 67 mm



General technical data		EAMD-16-15	EAMD-19-15	EAMD-25-22	EAMD-32-32
Type					
Mass moment of inertia	[kg mm ²]	0.355	0.445	3.2	14.5
Tightening torque of clamping screw D1	[Nm]	0.6	0.6	2	4
Tightening torque of clamping screw D2	[Nm]	1	1	1.5	7
Max. rotational speed	[1/min]	10,000	10,000	8,000	8,000
Corrosion resistance class CRC ¹⁾		1			
Materials	Hubs	Aluminium			
	Ring gear	Polyurethane			
Note on materials		RoHS-compliant			

Type		EAMD-42-40	EAMD-56-46	EAMD-67-51
Mass moment of inertia	[kg mm ²]	39	147	374
Tightening torque of clamping screw D1	[Nm]	8	15	35
Tightening torque of clamping screw D2	[Nm]	8.5	14	60
Max. rotational speed	[1/min]	6,000	5,500	4,500
Corrosion resistance class CRC ¹⁾		1		
Materials	Hubs	Aluminium		
	Ring gear	Polyurethane		
Note on materials		RoHS-compliant		

1) Corrosion resistance class 1 as per Festo standard 940 070
Components subject to low corrosion stress. Transport and storage protection. Parts that do not have primarily decorative surface requirements, e.g. in internal areas that are not visible or behind covers.

Couplings EAMD

Technical data

FESTO

Dimensions and ordering data

Download CAD data → www.festo.com

EAMD-16-.../EAMD-19-...

EAMD-...

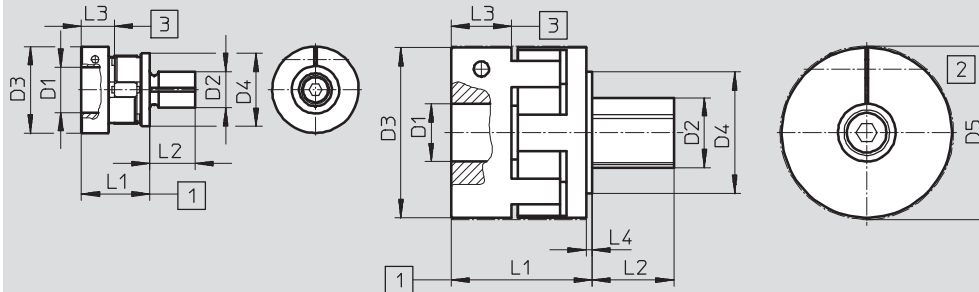

- 1 Nominal length with axial offset compensation
- 2 Min. installation \varnothing (interference profile of clamping screw)
- 3 Insertion depth

\varnothing [mm]	D1 \varnothing H7	D2 \varnothing H7	D3 \varnothing	D4 \varnothing	D5 \varnothing	L1	L2	L3	L4	Transferable torque [Nm]	Weight [g]	Part No.	Type
16	6.35	8	16	16	-	15	10	6	-	1.6	13	561292	EAMD-16-15-6,35-8X10
19	9	8	19	16	-	15	10	6	-	2	14	557999	EAMD-19-15-9-8X10
	10	8	19	16	-	15	10	6	-	2	13	557998	EAMD-19-15-10-8X10
25	6.35	10	25	22	-	22	12	8	1	3.6	44	561293	EAMD-25-22-6,35-10X12
	11	10	25	22	-	22	12	8	1	9	44	558000	EAMD-25-22-11-10X12
32	11	16	32	25	-	32	20	10	1.5	12.5	126	558001	EAMD-32-32-11-16X20
42	19	16	42	25	44.5	40	25	17	1.5	17	190	558002	EAMD-42-40-19-16X25
56	19	23	56	40	57	46	27	20	2	60	397	558003	EAMD-56-46-19-23X27
	20	23	56	40	57	46	27	20	2	60	397	558004	EAMD-56-46-20-23X27
	24	23	56	40	57	46	27	20	2	60	388	558005	EAMD-56-46-24-23X27
67	24	32	66.5	-	68	51	32	21	-	143	736	558008	EAMD-67-51-24-32X32
	25	32	66.5	-	68	51	32	21	-	150	734	558006	EAMD-67-51-25-32X32

Connecting shafts KSK

Type codes

For toothed belt axis DGE-...-ZR-KF

		KSK	25	800
Type				
KSK	Connecting shaft			
Size				
25	For toothed belt axis DGE-25-...-ZR-KF			
40	For toothed belt axis DGE-40-...-ZR-KF			
63	For toothed belt axis DGE-63-...-ZR-KF			
Nominal length L1				

For toothed belt axis EGC-...-TB-KF

		KSK	80	800
Type				
KSK	Connecting shaft			
Size				
50	For toothed belt axis EGC-50-...-TB-KF			
70	For toothed belt axis EGC-70-...-TB-KF			
80	For toothed belt axis EGC-80-...-TB-KF			
120	For toothed belt axis EGC-120-...-TB-KF			
185	For toothed belt axis EGC-185-...-TB-KF			
Nominal length L1				

Connecting shafts KSK

Technical data

FESTO

Connecting shafts KSK
for toothed belt axis DGE-ZR-KF

Ø - Size
25, 40 and 63

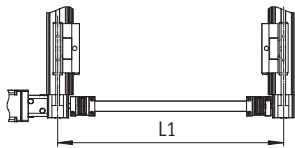

Nominal length L1 = Centre-to-centre distance between the axes

The total mass is calculated as follows:

$$m_{\text{total}} = m_0 + m_L \times L1$$

The moment of inertia is calculated as follows:

$$J_{\text{total}} = J_0 + J_L \times L1$$

General technical data			
Size	25	40	63
Design	Connecting tube with a coupling at each end		
Mounting position	Horizontal (vertical on request)		
Nominal length L1 [mm]	200 ... 2,000	250 ... 2,000	350 ... 2,000
Basic moment of inertia J_0 at L1 = 0 mm [kg mm ²]	31	147	1,310
Additional moment of inertia J_L per 1 m nominal length [kg mm ² /m]	34	80	333
Max. permissible axial offset [mm]	±2		
Basic weight m_0 at L1 = 0 mm [kg]	0.22	0.36	1.8
Additional weight m_L per 1 m nominal length [kg/m]	0.32	0.48	0.8

Operating and environmental conditions	
Ambient temperature [°C]	-10 ... +60
Corrosion resistance class CRC ¹⁾	2
Note on materials	RoHS-compliant Contains PWIS (paint-wetting impairment substances)
Coupling materials	Hubs: Wrought aluminium alloy Bellows: High-alloy steel
Connecting tube materials	High-alloy steel

1) Corrosion resistance class 2 as per Festo standard 940 070

Components subject to moderate corrosion stress. Externally visible parts with primarily decorative surface requirements which are in direct contact with a normal industrial environment or media such as coolants or lubricating agents.

Max. rotational speed n as a function of nominal length L1

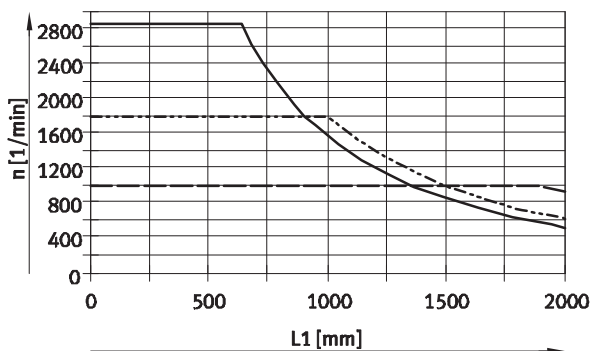

— KSK-25
- - - KSK-40
- · - KSK-63

Max. speed v as a function of nominal length L1

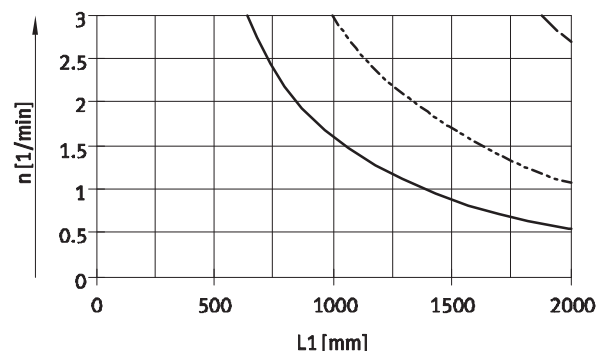

Connecting shafts KSK

Technical data

Dimensions and ordering data

Download CAD data → www.festo.com

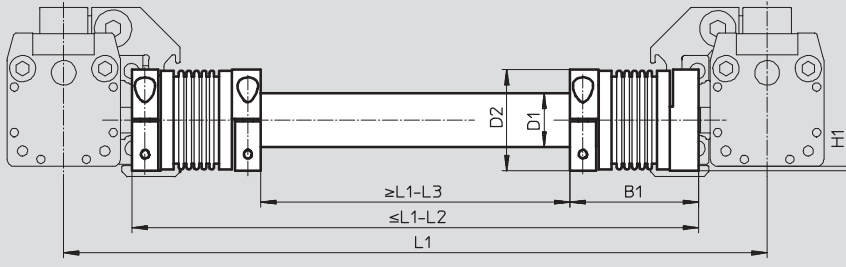

Size [mm]	B1	D1 ∅	D2 ∅	H1	L1	L2	L3	Part No.	Type
25	50	21.27	40	1.6	1)	51.4	156.4	196587	KSK-25-...
40	59	26.52	49	–		71.4	194.6	196588	KSK-40-...
63	94	41.6	81	–		114.6	308.6	196589	KSK-63-...

1) Centre-to-centre distance between the axes

Note

The nominal length L1 must be specified in the type code when ordering. The nominal length L1 indicates the centre-to-centre distance between the axes in this case.

Order example:

Two toothed belt axes DGE-40-...-ZR-KF are to be linked using a connecting shaft, nominal length L1 = 1,000 mm.

The following connecting shaft is required:

Type: KSK-40-1000
Part No.: 196 588

Connecting shafts KSK

Technical data

FESTO

Connecting shafts KSK
for toothed belt axis EGC-TB-KF

Ø - Size
50, 70, 80, 120 and 185

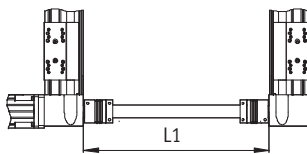

Nominal length L1 = Inside width
between the drive covers

The total mass is calculated
as follows:

$$m_{\text{total}} = m_0 + m_L \times L1$$

The moment of inertia is calculated
as follows:

$$J_{\text{total}} = J_0 + J_L \times L1$$

General technical data					
Size	50	70	80	120	185
Design	Connecting tube with a coupling at each end as well as 2 journals for adapting the hollow shaft				
Mounting position	Horizontal (vertical on request)				
Nominal length L1 [mm]	200 ... 2,000			250 ... 2,000	350 ... 2,000
Basic moment of inertia J_0 at L1 = 0 mm [kg mm ²]	34	35	159	1,390	7,261
Additional moment of inertia J_L per 1 m nominal length [kg mm ² /m]	34	34	80	333	1,946
Max. permissible axial offset [mm]	±2				±5
Basic weight m_0 at L1 = 0 mm [kg]	0.28	0.29	0.53	2.28	5.29
Additional weight m_L per 1 m nominal length [kg/m]	0.32	0.32	0.48	0.8	1.89

Operating and environmental conditions	
Ambient temperature [°C]	-10 ... +60
Corrosion resistance class CRC ¹⁾	2
Note on materials	RoHS-compliant Contains PWIS (paint-wetting impairment substances)
Coupling materials	Hubs: Wrought aluminium alloy Bellows: High-alloy steel
Connecting tube materials	High-alloy steel

1) Corrosion resistance class 2 as per Festo standard 940 070

Components subject to moderate corrosion stress. Externally visible parts with primarily decorative surface requirements which are in direct contact with a normal industrial environment or media such as coolants or lubricating agents.

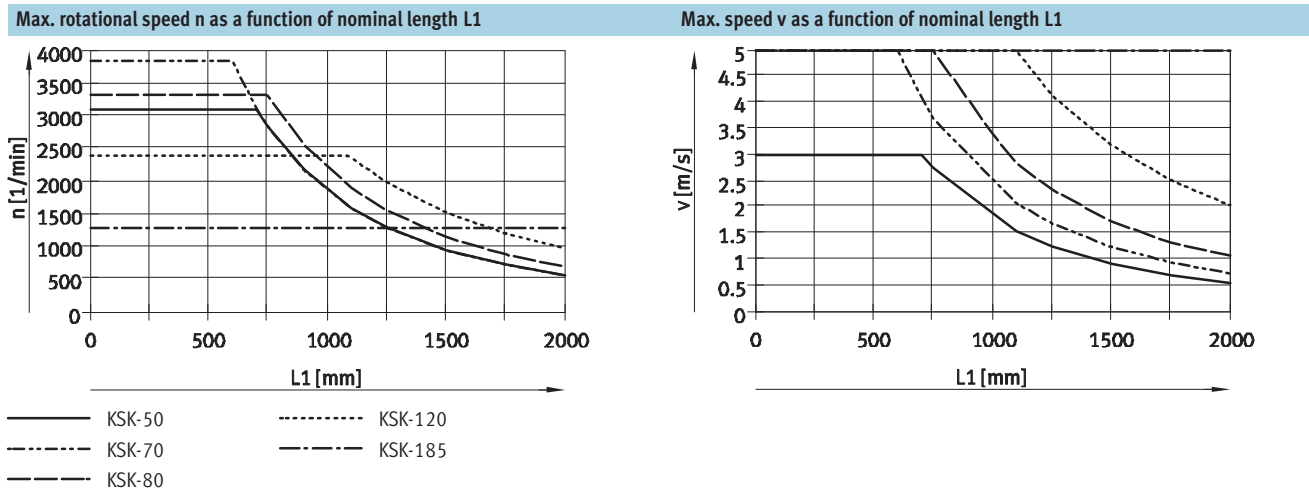

Connecting shafts KSK

Technical data

FESTO

Dimensions and ordering data

Download CAD data → www.festo.com

Guide, internal/external

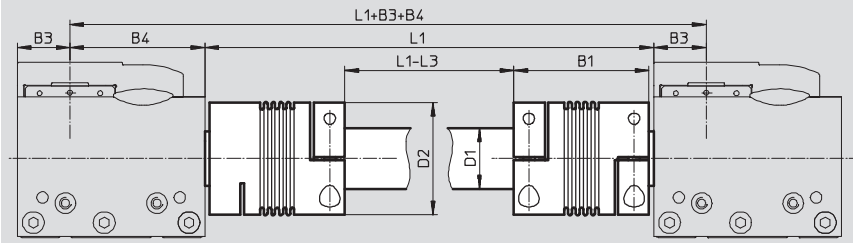

Guide, internal

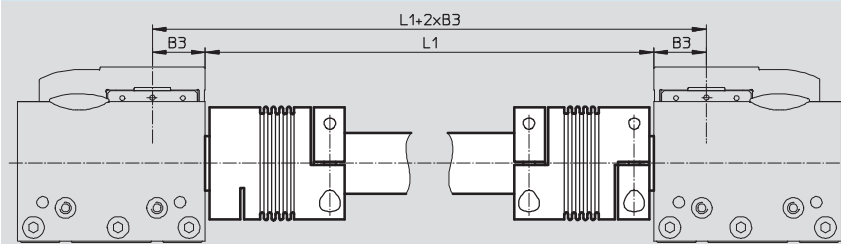

Guide, external

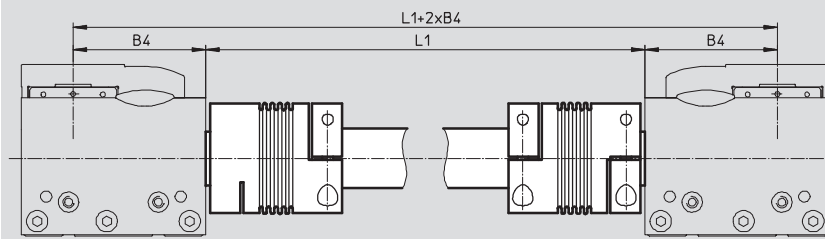

Projection of coupling

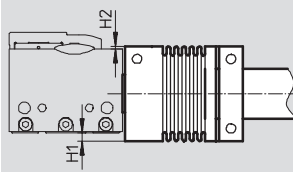

Size [mm]	B1	B3	B4	D1 ∅	D2 ∅	H1	H2	L1	L3	Part No.	Type
50	50	12.5	35.5	21.27	40	4	1	1)	102.2	563710	KSK-50-...
70	50	17.5	51.5	21.27	40	-	-		103.7	562520	KSK-70-...
80	59	23	59	26.52	49	-	-		122	562521	KSK-80-...
120	94	35	85	41.6	81	-	1		192	562522	KSK-120-...
185	111	55	131	65.4	110	-	-		228	562523	KSK-185-...

1) Inside width between the drive covers

Note

The nominal length L1 must be specified in the type code when ordering. The nominal length L1 indicates the inside width between the drive covers in this case.

Order example:

Two toothed belt axes EGC-70-...-TB-KF are to be linked using a connecting shaft, nominal length L1 = 1,000 mm.

The following connecting shaft is required:

Type: KSK-70-1000
Part No.: 562 520