



- To increase force and torque capacity
- Greater torsional resistance
- Reduced vibrations with dynamic loads

Passive guide axes/Heavy-duty guides, without drive

Key features

General information

- Driveless linear guide unit with guide and freely movable slide
- Heavy-duty guides are designed to increase force and torque capacities in multi-axis applications
- Higher torsional resistance
- Reduced vibrations with dynamic loads
- Drive axes and passive guide axes/heavy-duty guides can be arranged adjacent to one another or above one another

Passive guide axis DGC-FA, can be combined with linear drive DGC

→ 5 / 3.1-4

Recirculating ball bearing guide



- Size 8 ... 40
- Stroke lengths of 1 ... 5,000 mm
- Load capacity to max. 6,890 N or 380 Nm
- Precision guidance, for DGC-KF
- Wide range of options for mounting on drive units

Protected recirculating ball bearing guide



- Size 18 ... 40
- Stroke lengths of 1 ... 5,000 mm
- Load capacity to max. 6,890 N or 380 Nm
- Precision guidance, for DGC-KF
- Wide range of options for mounting on drive units
- The protected guide cleans the guide rail and protects the recirculating ball bearing guide with the aid of an additional wiper and a lubrication unit

Passive guide axis FDG, can be combined with toothed belt axis DGE-ZR-RF

→ 5 / 3.1-26

Roller guide



- Size 25 ... 63
- Stroke lengths of 1 ... 5,000 mm, depending on the version
- Load capacity to max. 1,500 N or 600 Nm
- Precision, rigid guide, suitable for DGE-ZR-RF
- Standard slide or extended slide, depending on the version
- Wide range of options for mounting on drive units
- System product for handling and assembly technology

Passive guide axis FDG, can be combined with linear drive DGPL/DGPIL or toothed belt axis DGE-ZR/spindle axis DGE-SP

→ 5 / 3.1-42

Recirculating ball bearing guide



- Size 18 ... 63
- Stroke lengths of 1 ... 5,100 mm, depending on the version
- Load capacity to max. 14,050 N or 1,820 Nm
- Precision, rigid guide, suitable for DGPL-KF and DGE-KF
- Standard slide or extended slide, depending on the version
- Wide range of options for mounting on drive units
- System product for handling and assembly technology
- Optional with additional slide

Protected version



- Sizes 25, 32, 40
- Stroke lengths of 1 ... 2,000 mm
- Load capacity to max. 7,300 N or 330 Nm
- Guide and slide are fitted with a cover to protect against the ingress of particles from above and from the side
- Wide range of options for mounting on drive units
- System product for handling and assembly technology

Heavy-duty guide HD

→ 5 / 3.1-64

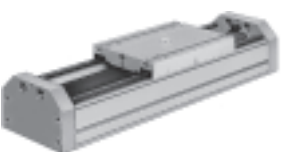

- Size HD8 ... HD40
- Stroke lengths of 10 ... 2,160 mm
- Load capacity to max. 5,600 N or 560 Nm
- Stable construction, greater rigidity
- High guide precision thanks to machined surfaces
- Wide range of options for mounting on drive units

Passive guide axes/Heavy-duty guides, without drive

System example

System product for handling and assembly technology

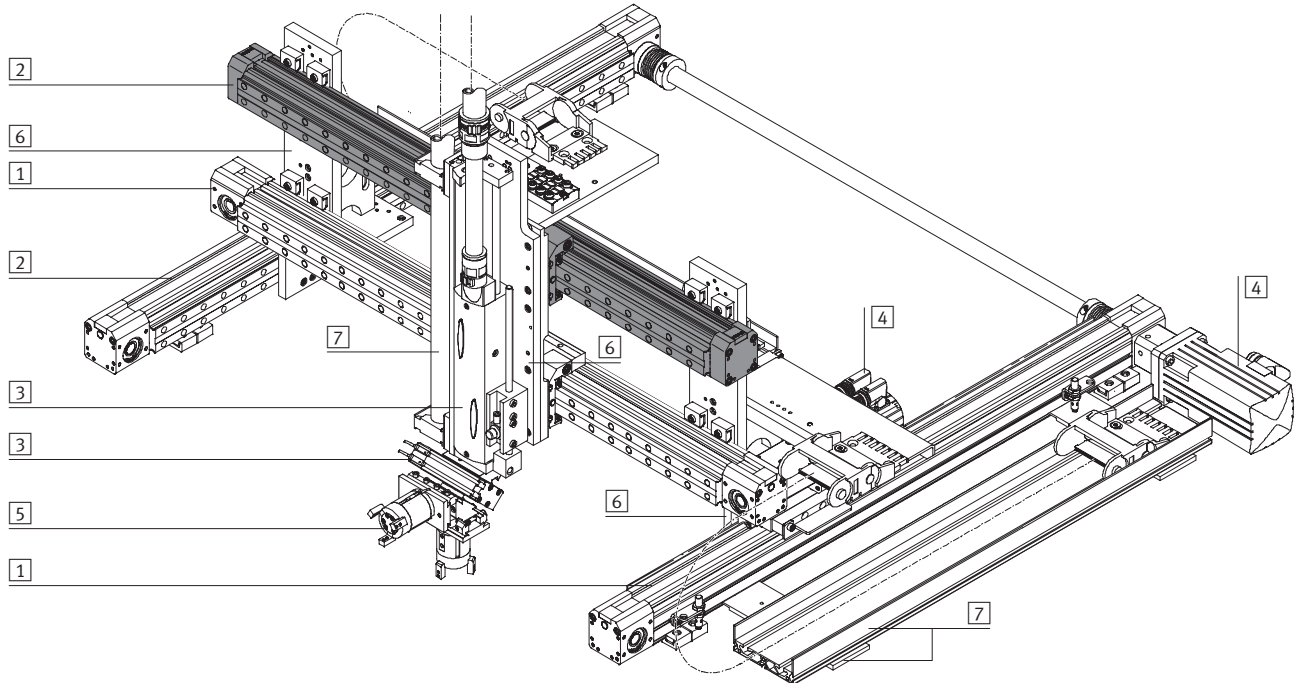

System elements and accessories		
	Brief description	→ Page
1	Axes	Diverse possible combinations in handling and assembly technology Volume 5
2	Passive guide axes	To increase force and torque capacity in multi-axis applications Volume 5
3	Drives	Diverse possible combinations in handling and assembly technology Volume 1
4	Motors	Servo and stepper motors, with or without gearing Volume 5
5	Grippers	Diverse variation options in handling and assembly technology Volume 1
6	Adapters	For drive/drive and drive/gripper combinations Volume 5
7	Installation components	For achieving a clear-cut, safe layout of electrical cables and tubing Volume 5

Passive guide axes DGC-FA, without drive

Peripherals overview



System components
Passive guide axes
3.1

-  - Note
1) End stops must not be removed.

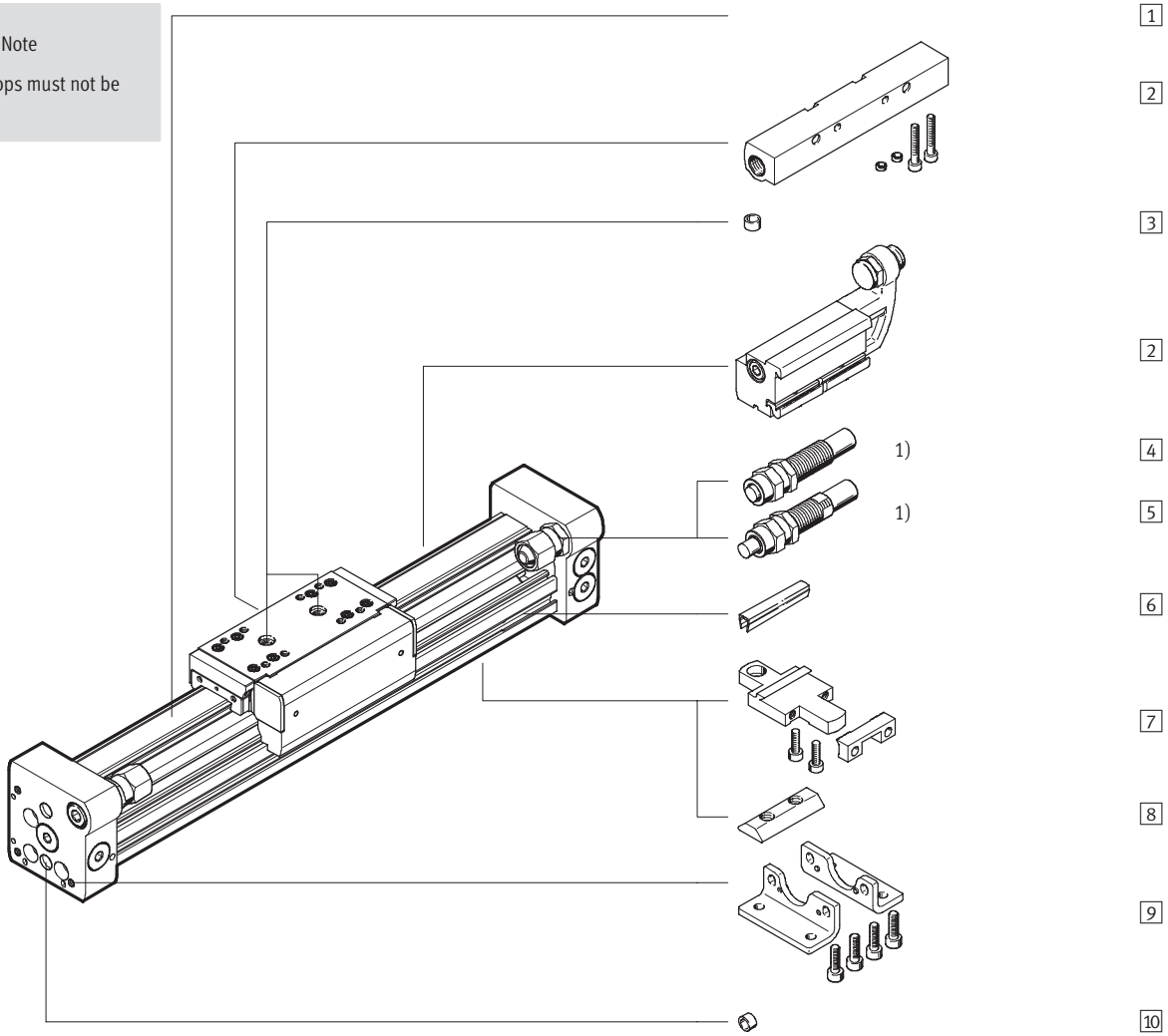

Passive guide axes DGC-FA, without drive

Peripherals overview

Variants and accessories		
Type	Brief description	→ Page
1 Passive guide axis DGC-FA	Passive guide axis without accessories	5 / 3.1-6
2 Mechanical end-position limiter YWZ	For variable end-position adjustment, e.g. with format adjustments	5 / 3.1-23
3 Centring pin/sleeve ¹⁾ ZBS/ZBH	For centring loads and attachments on the slide	5 / 3.1-25
– Cushioning P	Non-adjustable, flexible cushioning. Only used for low speeds	5 / 3.1-17
4 Shock absorber YSR	Self-adjusting hydraulic shock absorber with spring return and linear cushioning characteristic	5 / 3.1-17
5 Shock absorber YSRW	Self-adjusting hydraulic shock absorber with spring return and progressive cushioning characteristic	5 / 3.1-17
6 Slot cover L	For protecting against ingress of dirt and securing proximity sensor cables	1 / 3.1-64
7 Profile mounting M	Simple and precise mounting option via dovetail connection	5 / 3.1-22
8 Slot nut B	For mounting attachments	5 / 3.1-25
9 Foot mounting F	For mounting on end cap	5 / 3.1-18
10 Centring pin/sleeve ¹⁾ ZBS/ZBH	For centring the drive DGC without foot mountings (user-specific)	5 / 3.1-25

1) Included in the scope of delivery for the axis

Passive guide axes DGC-FA, without drive

Type codes





		DGC	-	25	-	500	-	FA	-	YSR	-		-		-	FL	-		
Type																			
DGC	Linear drive																		
Piston \varnothing [mm]																			
Stroke [mm]																			
Guide																			
FA	Guide axis																		
Cushioning																			
P	Flexible cushioning, non-adjustable																		
YSR	Shock absorber, linear, self-adjusting																		
YSRW	Shock absorber, progressive, self-adjusting																		
Slide																			
GP	Protected recirculating ball bearing guide																		
Additional slide																			
K	Additional slide																		
Accessories																			
F	Foot mounting																		
... M	Profile mounting																		
... B	Slot nut for mounting slot																		
YWZ1	Variable end position, at one end																		
YWZ2	Variable end position, at both ends																		
...L	Slot cover for sensor slot																		
User's manual																			
0	Express waiver – no user manual to be included																		

Passive guide axes DGC-FA, without drive



Technical data

-  Diameter
8 ... 40 mm
-  Stroke length
1 ... 5,000 mm

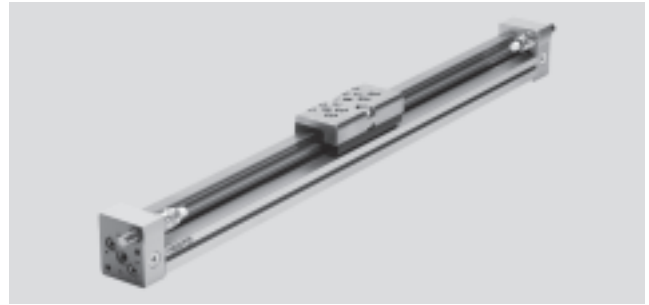

General technical data							
Piston Ø		8	12	18	25	32	40
Stroke	[mm]	1 ... 1,300	1 ... 1,900	1 ... 3,000	1 ... 5,000		
Guide		External recirculating ball bearing guide					
Assembly position		Any					
Cushioning		Non-adjustable at either end					
→ 5 / 3.1-9		Self-adjusting at both ends					
Type of mounting		Profile mounting					
		Foot mounting					
		Direct mounting					
Max. speed	[m/s]	1	1.2	3			
Repetition accuracy	[mm]	0.02 (with shock absorber YSR/YSRW)					
Stroke tolerance	[mm]	0 ... 1.7			0 ... 2.5		

Operating and environmental conditions	
Ambient temperature	[°C] -10 ... +60
Corrosion resistance class CRC ¹⁾	1

1) Corrosion resistance class 1 according to Festo standard 940 070
Components requiring low corrosion resistance. Transport and storage protection. Parts that do not have primarily decorative surface requirements, e.g. in internal areas that are not visible or behind covers.

Weights [g]							
Piston Ø		8	12	18	25	32	40
Basic weight per 0 mm stroke		225	391	975	2,113	2,837	6,996
Additional weight per 10 mm stroke		11	16	31	49	47	117
Moving load		77	149	331	732	1,146	2,330

Adjustable end-position range L [mm]							
Piston Ø		8	12	18	25	32	40
Cushioning P	[mm]	0 ... 5		-			
Cushioning YSR/YSRW	[mm]	0 ... 10		0 ... 20	0 ... 25		

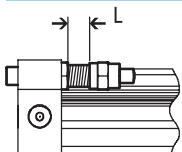

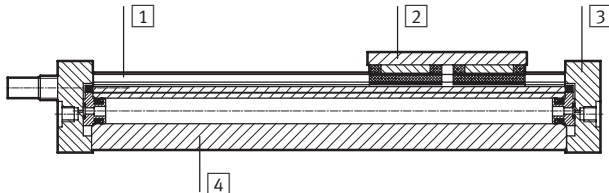
Materials		
Sectional view		
	Passive guide axes	
1	Guide rail	High-alloy steel
2	Slide	High-alloy steel
3	End cap	Anodised aluminium
4	Cylinder barrel	Anodised aluminium
-	Sealing band	Polyurethane

Passive guide axes DGC-FA, without drive

Technical data



Characteristic load values

The indicated forces and torques refer to the centre of the guide rail and the middle of the slide. They must not be exceeded during dynamic operation. Special attention must be paid to the cushioning phase.

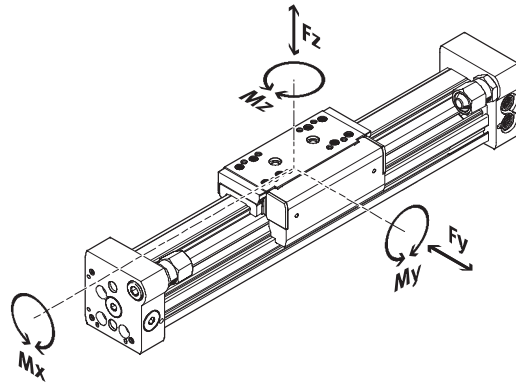

GP – Protected guide

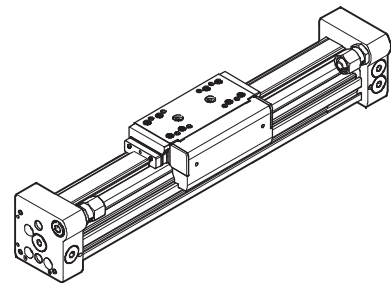

If the drive is simultaneously subjected to several of the indicated forces and torques, the following equation must be satisfied in addition to the indicated maximum loads.

$$\frac{F_y}{F_{y_{max}}} + \frac{F_z}{F_{z_{max}}} + \frac{M_x}{M_{x_{max}}} + \frac{M_y}{M_{y_{max}}} + \frac{M_z}{M_{z_{max}}} \leq 1$$

Permissible forces and torques							
Piston Ø		8	12	18	25	32	40
F _y _{max.}	[N]	300	650	1,850	3,050	3,310	6,890
F _z _{max.}	[N]	300	650	1,850	3,050	3,310	6,890
M _x _{max.}	[Nm]	1.7	3.5	16	36	54	144
M _y _{max.}	[Nm]	4.5	10	51	97	150	380
M _z _{max.}	[Nm]	4.5	10	51	97	150	380



Selection and ordering aid
ProDrive
www.festo.com/en/engineering

Passive guide axes DGC-FA, without drive

Technical data

Maximum permissible slide speed v as a function of working load m

Piston \varnothing 8/12 with P cushioning

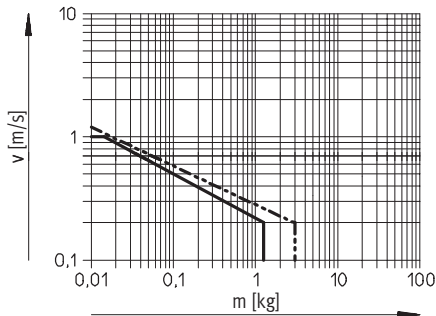

Piston \varnothing 8 ... 40 with YSR cushioning

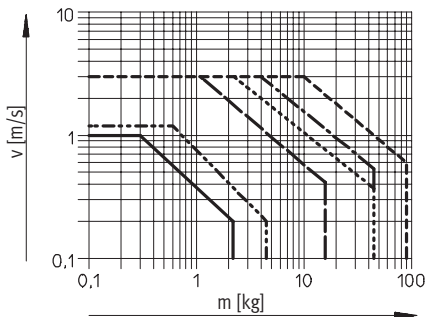

Piston \varnothing 8 ... 40 with YSRW cushioning

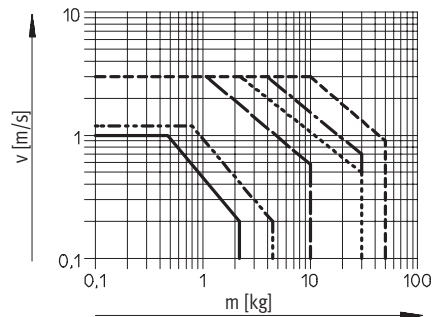

- \varnothing 8
- - - \varnothing 12
- \varnothing 18
- · · \varnothing 25
- \varnothing 32
- - - \varnothing 40

- Note

This data represents the maximum values that can be achieved. Values fluctuate in practice relative to the size of the effective load.

Operating range of cushioning

The end-position cushioning must be adjusted to ensure jerk-free operation. If the operating conditions are outside the permissible range, the

load to be moved must be cushioned using suitable equipment (shock absorbers, stops, etc.), preferably at the centre of gravity of the mass.

- Note

To avoid distortion in the slide, the bearing surfaces of the attachments must maintain a flatness of at least:

- with piston \varnothing 8 and 12: 0.03 mm
- with piston \varnothing 18 ... 40: 0.01 mm

The data applies to a horizontal mounting position:

Piston \varnothing	8	12	18	25	32	40
Distance r_{max} [mm]	25	35	35	50	50	50

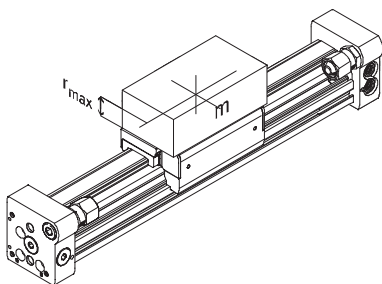

Passive guide axes DGC-FA, without drive

Technical data



System components
Passive guide axes

3.1

Number of profile mountings MUC dependent on force due to weight F and support span l

In order to limit deflection in the case of large strokes, the guide axis may need to be supported. The following

diagrams serve to determine the maximum permissible support span

as a function of the mounting position and the perpendicular force.

Horizontal assembly position

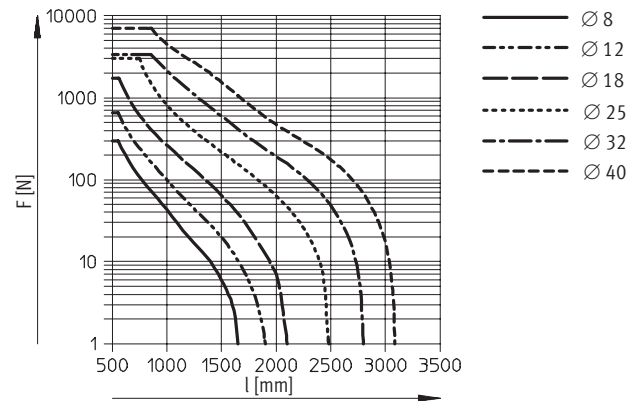
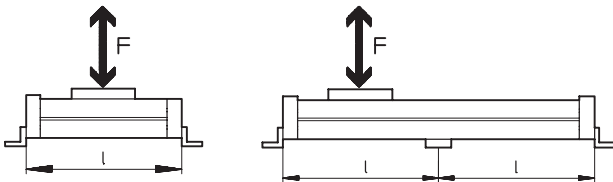

Vertical assembly position

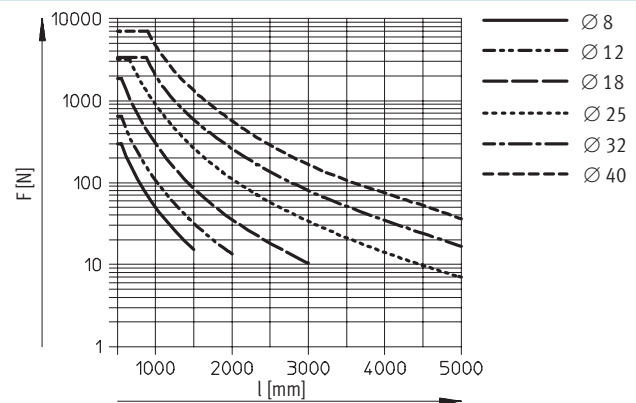
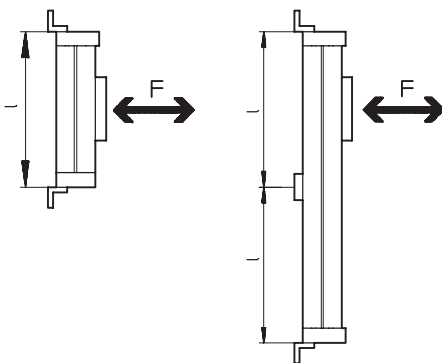

Example:

The guide axis DGC-25-1500 is subjected to a force of 300 N in the horizontal assembly position.

The axis has an overall length of:
 $l = \text{stroke length} + L1$
 (see dimensions)
 $= 1,500 \text{ mm} + 200 \text{ mm}$
 $= 1,700 \text{ mm}$

According to the diagram, the max. support span is 1,300 mm for the axis DGC-25 with a force of 300 N.

In this example, profile mounting attachments are required as the max. support span (1,300 mm) is smaller than the overall length of the axis (1,700 mm).

Passive guide axes DGC-FA, without drive

Technical data



Dimensions Download CAD data → www.festo.com/en/engineering

∅ 8 and 12

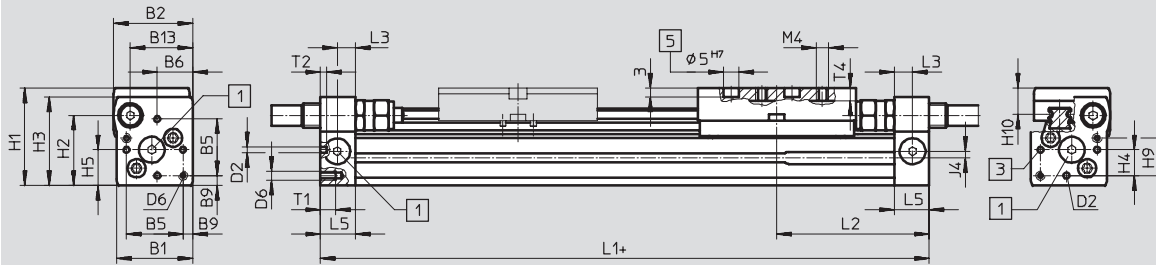

- + plus stroke length
- 1 The ports on the end caps are sealed with blanking plugs
- 3 Mounting hole for foot mounting or centring pin
- 4 Additional slide KL
- 5 Hole for centring pin ZBS

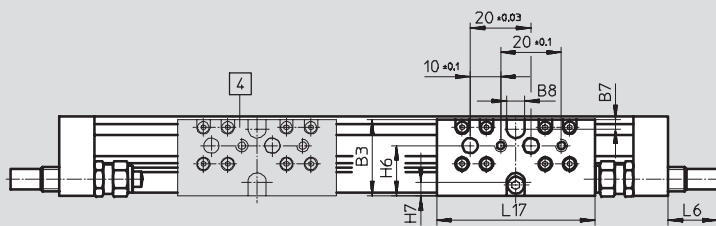

∅	B1	B2	B3	B5	B6	B7	B8	B9	B13	D2	D6	H1	H2	H3	H4	H5
[mm]							±0.05	±0.1		∅ H8						
8	25	26	25	18.6	11.7	3	6	3.2	20.5	2	M3	32	23	29	8.5	11.7
12	30.2	31	31	20.6	13.5	3	8	4.8	25	2	M4	37.5	28.5	34.5	8.7	13.5

∅	H6	H7	H9	H10	J4	L1	L2	L3	L5	L6			L17	T1	T2	T4
										P	YSR	YSRW				
[mm]						+0.5/ -0.4										
8	16.5	4.5	12.3	8.7	2.2	100	50.1	6	11.5	0	16	16.2	52	5	2	4.3
12	20.5	5	14.7	9.8	3	125	62.1	8	16	0	11.3	12.3	65	6	2	5

Passive guide axes DGC-FA, without drive

Technical data



Dimensions

Download CAD data → www.festo.com/en/engineering

Ø 18 ... 40

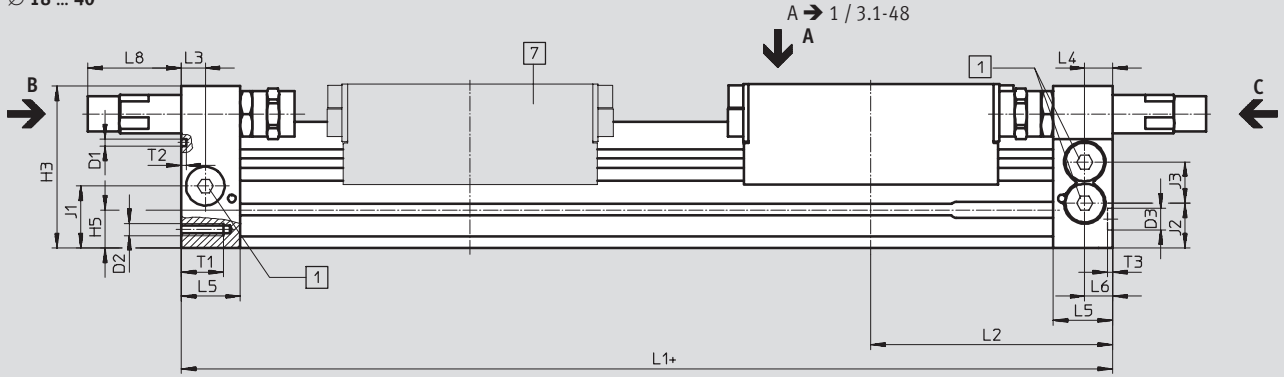

View C

Ø 18 ... 40

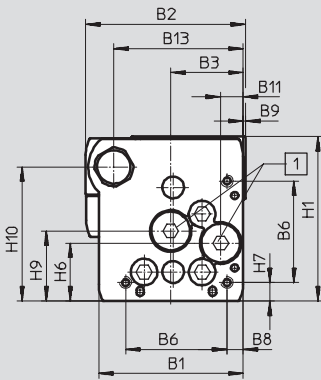

View B

Ø 18

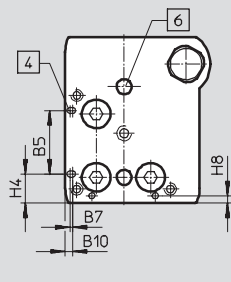

Ø 25 ... 40

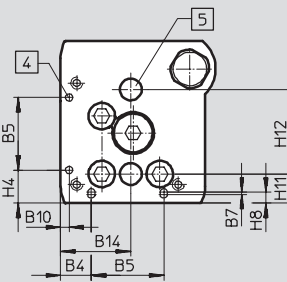

Ø 18 ... 40

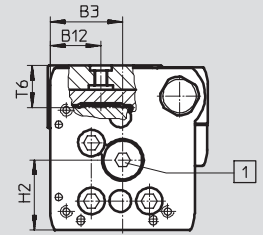

- + plus stroke length
- 1 The ports on the end caps are sealed with blanking plugs

- 4 Mounting hole for foot mounting HPC
- 5 Hole for centring sleeve ZBH

- 6 Hole for centring pin ZBS
- 7 Additional slide

Passive guide axes DGC-FA, without drive

Technical data

∅	B1	B2	B3	B4	B5	B6	B7	B8	B9	B10	B11	B12
[mm]			±0.05	±0.1	±0.05	±0.1		±0.1			±0.05	
18	44.5	49.9	19.5	8.8	21	31	0.8	3.8	1	2.4	5.5	15.5
25	59.8	66	30	12.65	30	42	1	6.65	1	3.5	9.3	21
32	73	79	38.5	5.7	63.1	57.5	–	8.5	1.5	14	14.9	18
40	91	98.5	45	17.2	55	65	–	12.2	2	8	16.5	24.8

∅	B13	B14	D1	D2	D3	H1	H2	H3	H4	H5	H6
[mm]	±0.1	±0.05	∅ ±0.05		∅ H7		±0.1		±0.1		±0.1
18	39	19.5	2	M4	5	56.3	23.1	55	9.6	13.4	20
25	53	29	3	M5	9	68	29	67	13.65	15.8	24
32	65	38.5	3	M6	9	78.5	30	77	5.7	17	27.7
40	80.5	45	4	M6	9	99.5	41.5	97.5	17.2	25	36.5

∅	H7	H8	H9	H10	H11	H12	J1	J2	J3	L1	
										KF	KF-GP
[mm]	±0.1	±0.1	±0.1	±0.1	±0.05	±0.05	±0.1	±0.1	±0.1	+0.9/-0.2	+0.9/-0.2
18	4.6	2.4	25.2	46	8.5	30	20	16.5	11	150	157
25	7.65	4.5	29	55.5	12	35	26.1	18.6	17	200	205
32	8.5	14	35.2	63.8	11.45	50	30	22	18.5	250	250
40	12.2	8	44	81.5	15	60	35	26	26	300	312

∅	L2		L3	L4	L5	L6	L8		T1	T2	T3	T6
	KF	KF-GP					YSR	YSRW				
[mm]											+0.2	
18	74.5	78	5.7	5.8	15	5.5	29.9	32.4	9	2	3.1	15
25	100	102.5	10.5	10.6	24.5	10.6	35.6	38.6	17.5	2	2.1	17.3
32	124.8	124.8	14.5	14.5	30.5	14.5	19.5	28	15	2	2.1	20
40	150	156	14.6	14.6	33.5	14.6	38.5	43.5	20	3	2.1	25.7

Profile barrel

∅ 25

∅ 32

∅ 40

2 Mounting slot for slot nut

Passive guide axes DGC-FA, without drive

Technical data



Dimensions

Download CAD data → www.festo.com/en/engineering

Slide

Ø 18

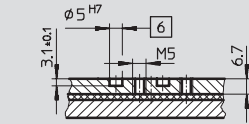

View A

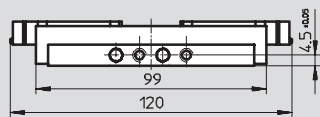
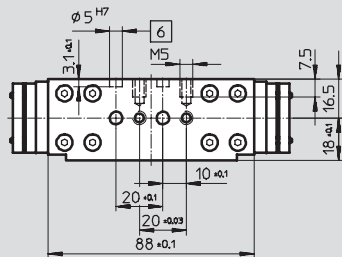

Ø 25

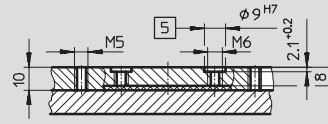

View A

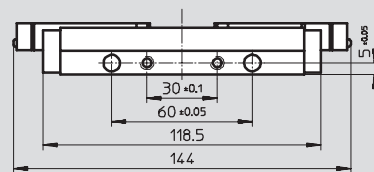
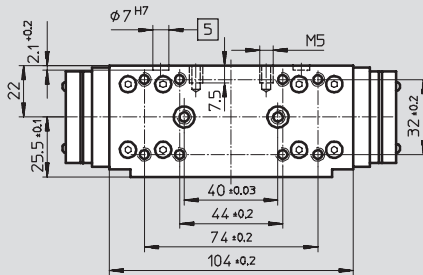

Ø 32

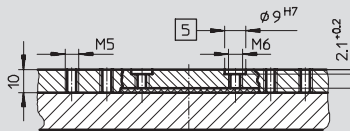

View A

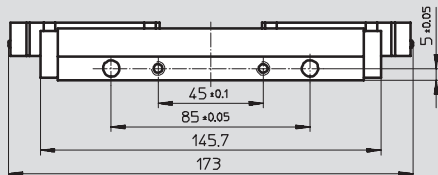
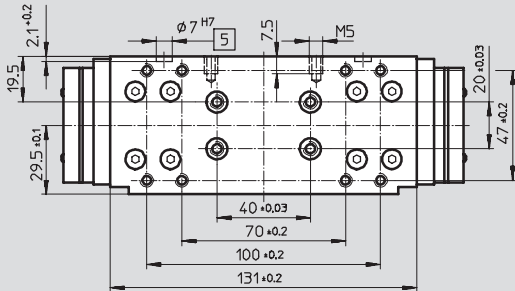

Ø 40

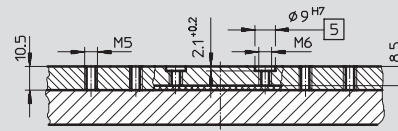

View A

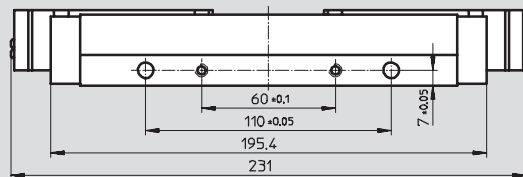
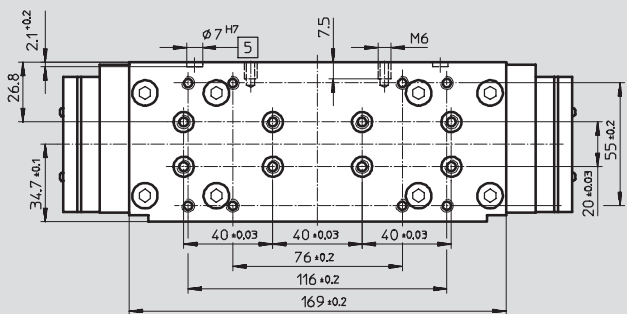

5 Hole for centring sleeve ZBH

6 Hole for centring pin ZBS

Passive guide axes DGC-FA, without drive

Technical data



Dimensions

Download CAD data → www.festo.com/en/engineering

Slide, variant GP – Protected recirculating ball bearing guide

∅ 18

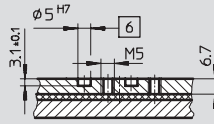

View A

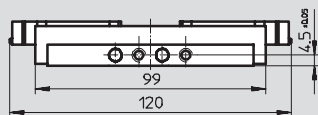
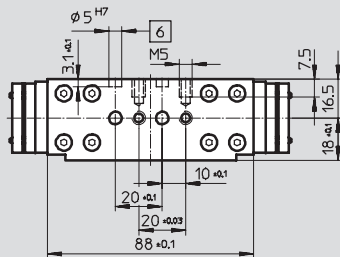

∅ 25

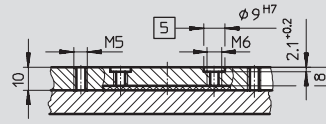

View A

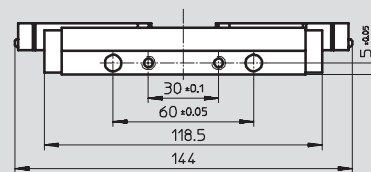
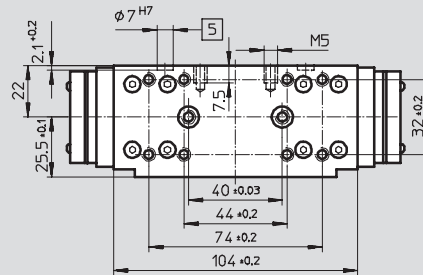

∅ 32

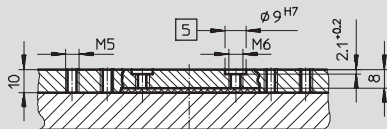

View A

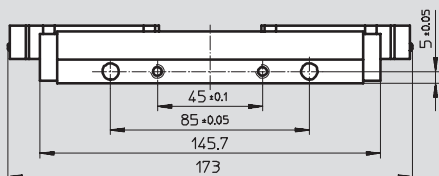
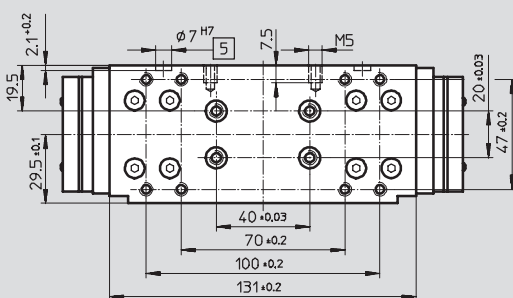

∅ 40

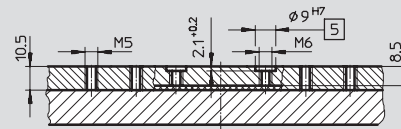

View A

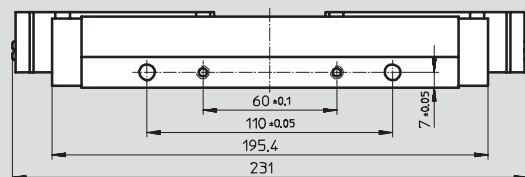
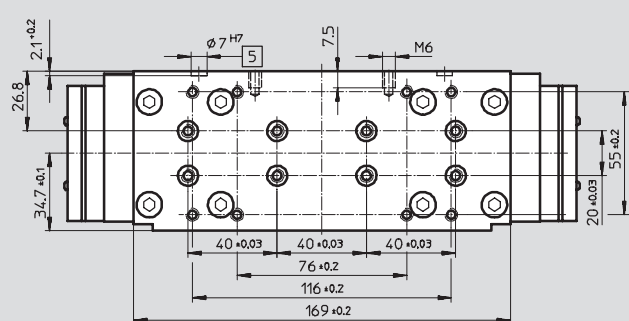

5 Hole for centring sleeve ZBH

6 Hole for centring pin ZBS

Passive guide axes DGC-FA, without drive

Ordering data – Modular products



Order code

Mandatory data/options

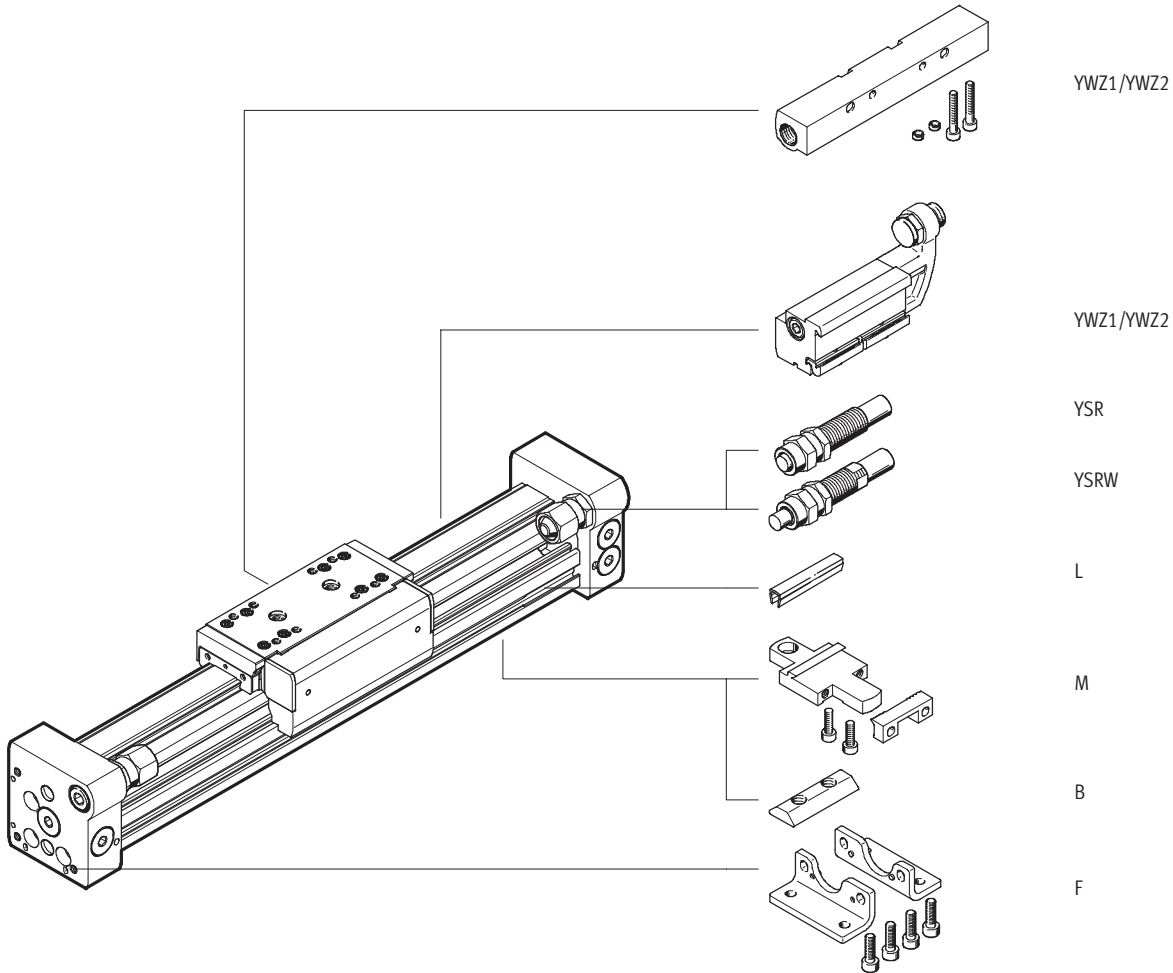

Effective stroke reduction when ordering an additional slide K

For a guide axis DGC with additional slide, the effective stroke is reduced by the length of the additional slide and the distance between both slides.

Given:
DGC-12-500-...
L = 20 mm
L17 = 65 mm

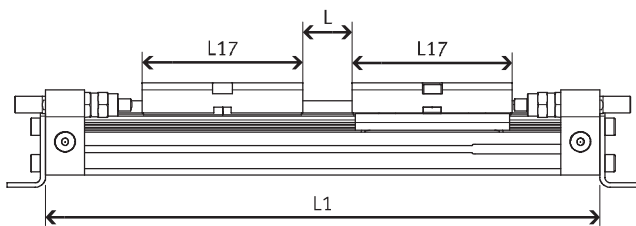

The effective stroke is reduced to
415 mm = 500 mm – 20 mm – 65 mm

∅ [mm]	8	12	18	25	32	40
L17	52	65	99	118.5	145.7	195.4

Passive guide axes DGC-FA, without drive

Ordering data – Modular products



[M] Mandatory data						[O] Options			
Module No.	Function	Piston Ø	Stroke	Guide	Cushioning	Slide	Additional slide	Accessories	User's manual
530 906	DGC	8	1 ... 5 00	FA	P	GP	...K	F, ...M, ...B, YWZ1, YWZ2, ...L	0
530 907		12	0		YSR				
532 446		18			YSRW				
532 447		25							
532 448		32							
532 449		40							
Order example									
530 906	DGC	- 8	- 250	- FA	- YSR		1K	+ F3M	

Ordering table										
Size	8	12	18	25	32	40	Condi- tions	Code	Enter code	
[M] Module No.	530 906	530 907	532 446	532 447	532 448	532 449				
Function	Linear axis							DGC		DGC
Piston Ø [mm]	8	12	18	25	32	40		-...		
Stroke [mm]	1 ... 1 300	1 ... 1 900	1 ... 3 000	1 ... 5 000				-...		
Guide	Guide axis without drive							-FA		-FA
Cushioning	Flexible cushioning rings/plates at both ends							-P		
	Shock absorber, self-adjusting							-YSR		
	Shock absorber, self-adjusting, progressive							-YSRW		
[O] Slide	-	-	Protected recirculating ball bearing guide				[1]	-GP		
Additional slide	1 ... 2							[2]	-...K	
Accessories	Supplied loose (can be retrofitted)							+		+
Foot mounting	1							F		
Profile mounting	1 ... 9							...M		
Slot nut for mounting slot	-	-	-	1 ... 9				...B		
Mechanical end-position limiter	Variable end position, at one end							[3]	YWZ1	
	Variable end position, at both ends							[3]	YWZ2	
Slot cover for sensor slot	1 ... 9							...L		
User's manual	Express waiver – no user manual to be included							-O		

- [1] GP Not with YSR and YSRW cushioning
- [2] K For a guide axis DGC with additional slide, the effective stroke is reduced by the length of the additional slide and the distance between both slides
- [3] YWZ1, YWZ2 Only with YSR or YSRW cushioning

Transfer order code

DGC - - - **FA** - - - + -

Passive guide axes DGC-FA, without drive

Accessories



Foot mounting HPC
(order code: F)

Material:
Galvanised steel

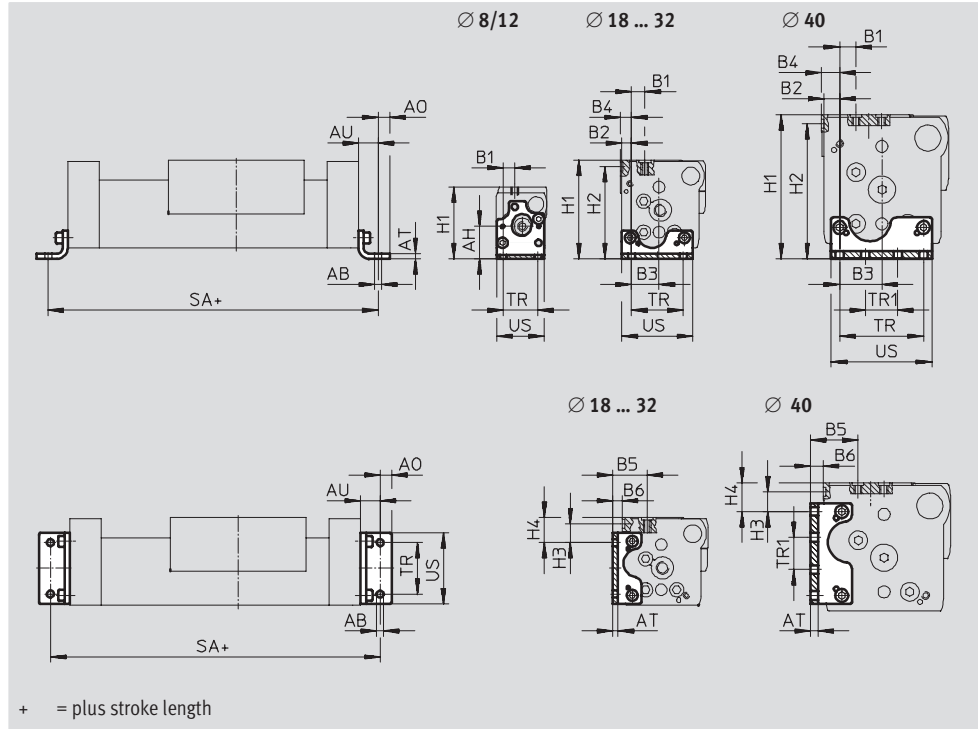

+ = plus stroke length

Dimensions and ordering data									
For Ø [mm]	AB Ø	AH	AO	AT	AU	B1		B2	B3
						G	GF/KF		
8	3.4	16.7	3	2	9	6	6	-	-
12	4.5	18.5	4.5	2	11.5	5.4	5.4	-	-
18	5.5	-	6.75	3	13.25	15	11.2	4.3	15.2
25	5.5	-	9	4	15	12.5	13.35	7.65	21.35
32	6.6	-	10	5	19	19	11.5	9	29.5
40	6.6	-	10	6	20	7.6	12.6	12.2	32.8

For Ø [mm]	B4 GF/KF	B5		B6 GF/KF	H1		H2 GF/KF	H3 GF/KF
		G	GF/KF		G	GF/KF		
8	-	-	-	-	37	37	-	-
12	-	-	-	-	42.5	42.5	-	-
18	5.3	27	23.2	6.7	57.5	64	59.5	16.7
25	8.65	36.65	29.5	7.5	67	76.5	71.5	14.35
32	10.5	29.5	27	7.5	82	87.5	82.5	8
40	14.2	31.8	36.8	10	100	111.5	104.5	15.3

For Ø [mm]	H4		SA +0.9/-0.2	TR ±0.1	TR1 ±0.1	US	Weight [g]	Part No.	Type
	G	GF/KF							
8	-	-	118	18	-	24.4	26	526 385	HPC-8
12	-	-	148	20	-	29.6	38	526 388	HPC-12
18	14.7	21.5	176	30	-	38.6	58	533 667	HPC-18
25	9.85	19.35	230	40	-	55	131	533 668	HPC-25
32	7.5	13	288	56.5	19.5	68	239	533 669	HPC-32
40	10.8	22.3	340	65	25	78	348	533 670	HPC-40

Passive guide axes DGC-FA, without drive

Accessories



Foot mounting HPC-S

(when replacing linear drive DGPL with linear drive DGC-GF/-KF)

Material:

Galvanised steel

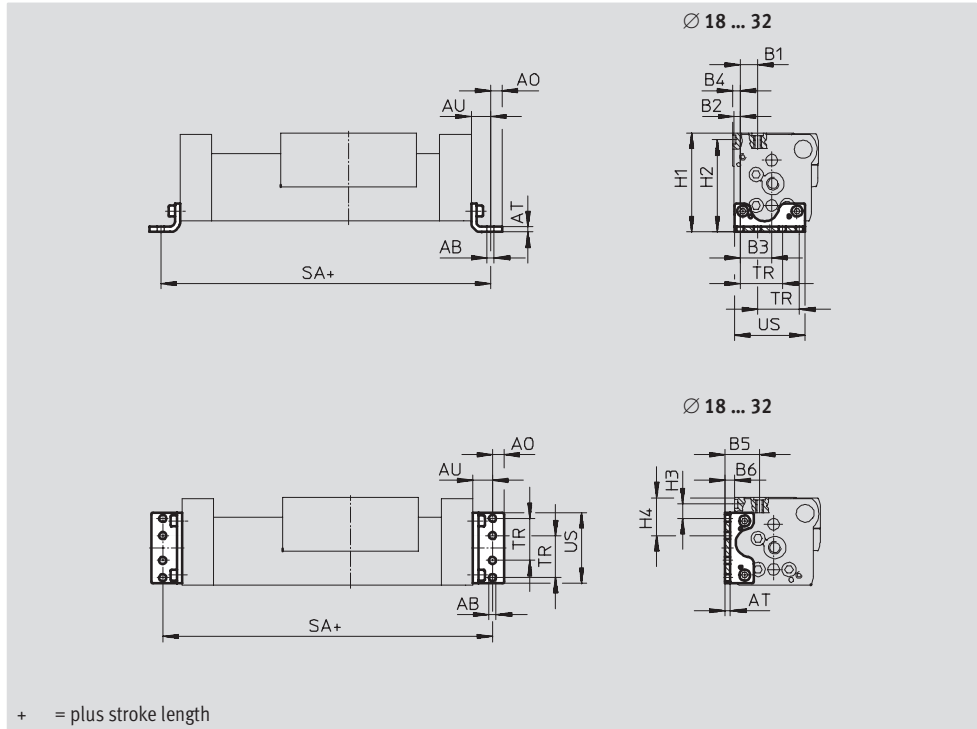

Dimensions and ordering data

For Ø	AB	AO	AT	AU	B1	B2	B3	B4	B5	B6
[mm]	Ø									
18	5.5	4.75	3	13.25	12	3.5	15.6	4.5	24	7.5
25	5.5	6	3	13	16.25	4.75	24.25	5.75	29.5	7.5
32	6.6	7	4	17	9	9	29.5	10.5	27	7.5

For Ø	H1	H2	H3	H4	SA	TR	US	Weight	Part No.	Type
[mm]					+0.9/-0.2	±0.1		[g]		
18	64	59.5	16.7	28	176.5	24	40	54.5	535 600	HPC-18-S
25	75.5	70.5	11.45	29.75	226	32.5	55	89.5	535 601	HPC-25-S
32	87.5	82.5	8	31.5	284	38	68	180	538 413	HPC-32-S

Passive guide axes DGC-FA, without drive

Accessories



Foot mounting HPC-SO

(when replacing linear drive DGPL with linear drive DGC-GF/-KF)

Material:

Galvanised steel

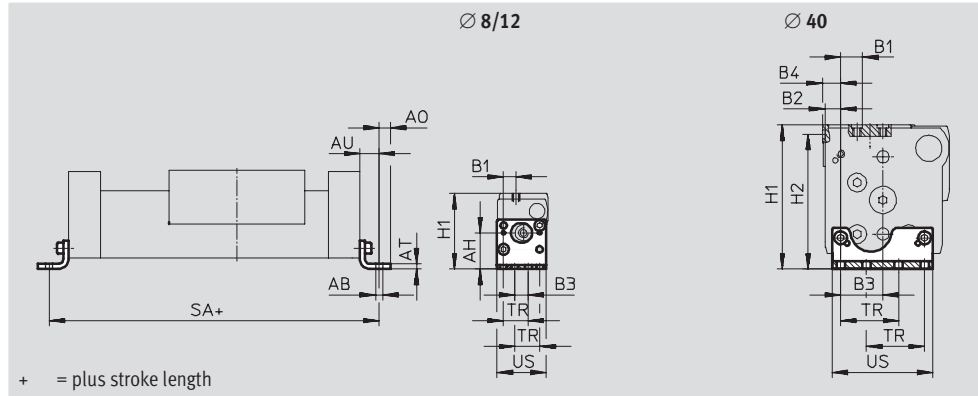

System components
Passive guide axes

3.1

Dimensions and ordering data

For Ø	AB Ø	AH	AO	AT	AU	B1	B2	B3
8	3.4	18.7	3	2	9	6.5	-	7
12	3.4	23.5	3	2	9	9.3	-	9.4
40	6.6	-	8.5	5	17.5	12.5	12.3	32.7

For Ø	B4	H1	H2	SA	TR	US	Weight	Part No.	Type
8	-	39	-	118	13	25.4	26	529 346	HPC-8-SO
12	-	47.5	-	143	18.6	33.8	42	529 348	HPC-12-SO
40	14.3	104.5	97.5	335	45	78	264	536 745	HPC-40-SO

Passive guide axes DGC-FA, without drive



Accessories

Foot mounting HPC-SH
(when replacing linear drive DGPL
with linear drive DGC-GF/-KF)

Material:
Galvanised steel

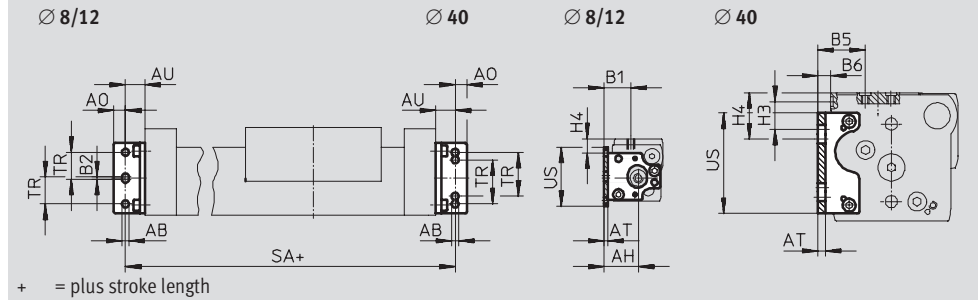

Dimensions and ordering data								
For Ø	AB Ø	AH	AO	AT	AU	B1	B2	B5
[mm]								
8	3.4	17.8	3	2	9	13.8	1.5	-
12	3.4	21.1	3	2	9	16.5	1.4	-
40	6.6	-	8.5	5	17.5	-	-	36

For Ø	B6	H3	H4	SA	TR	US	Weight	Part No.	Type
[mm]				+0.9/-0.2	±0.1		[g]		
8	-	-	7.25	118	13	30.5	25	529 347	HPC-8-SH
12	-	-	4.5	143	18.6	41.8	41.5	529 349	HPC-12-SH
40	9.2	21.6	36	335	45	78	275	536 746	HPC-40-SH

Passive guide axes DGC-FA, without drive

Accessories



Profile mounting MUC

(order code: M)

Material:

High-alloy steel

MUC-12



Ø 8/12

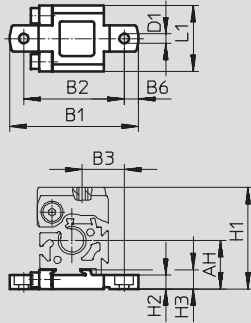

Ø 18 ... 40

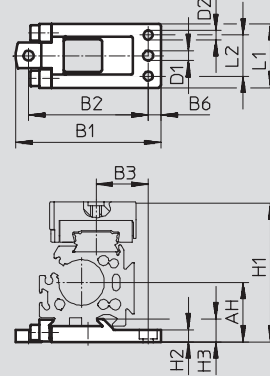

Ø 18 ... 40-GF/KF

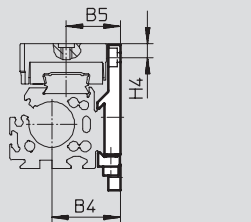

Ø 18 ... 40-G

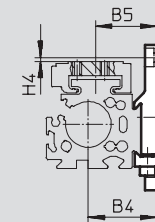

Position of the profile mounting along the profile barrel is freely selectable.

Dimensions and ordering data

For Ø [mm]	AH	B1	B2 ±0.2	B3		B4	B5		B6	D1 Ø	D2 Ø H7
				G	GF/KF		G	GF/KF			
8	17.7	47	36.7	15.35	15.35	–	–	–	5.1	3.5	–
12	18.5	52.5	42.2	16.5	16.5	–	–	–	5.1	3.5	–
18	27.2	67.8	56	32.5	28.7	27.2	27	28.7	5.7	5.5	5
25	32.5	79.5	65.5	35.15	28.5	37.5	36.15	29.5	7	5.5	5
32	37.5	94	80	35	35	47.5	37	37	7	5.5	5
40	47	110.5	96	43	43	57	46.8	46.8	7	6.5	6

For Ø [mm]	H1		H2	H3	H4		L1	L2	Weight [g]	Part No.	Type
	G	GF/KF			G	GF/KF					
8	37	37	5	7	–	–	24	–	28	526 384	MUC-8
12	42.5	42.5	4.5	7	–	–	24	–	32	526 387	MUC-12
18	57.5	64	5.7	9.9	0.1	6.4	33	20.5	78	531 752	MUC-18
25	67	76.5	6.5	12.5	2.07	7.43	35	22.5	113	531 753	MUC-25
32	82	87.5	6.5	13	1.5	4	45	30	174	531 754	MUC-32
40	100	111.5	8.5	16	0.2	11.3	60	44	346	531 755	MUC-40

Passive guide axes DGC-FA, without drive

Accessories

Shock absorber retainer DADP

Stop KYC

(order code: YWZ1 or YWZ2)

Materials: Stop housing: Anodised aluminium
 Stop bracket: Special steel casting
 Clip: High-alloy steel
 Free of copper and PTFE (paint wetting impairment substances)

Materials; Shock absorber retainer housing: Anodised aluminium
 Free of copper and PTFE (paint wetting impairment substances)

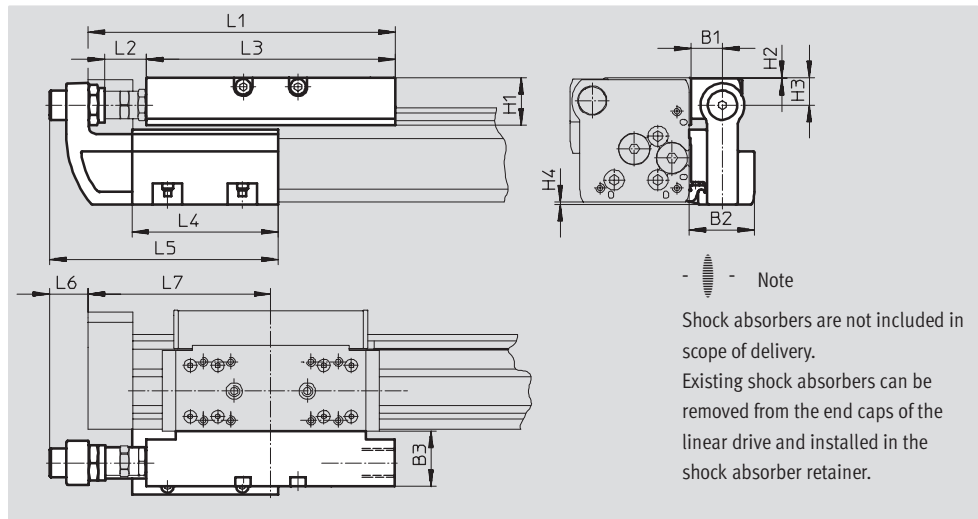

Dimensions								
For Ø		B1	B2	B3	H1	H2	H3	H4
[mm]								
18	GF	16	34.5	29	20.7	0.2	12.5	0.7
	KF	16	34.5	29	20.7	0.2	12.5	0.7
25	GF	16.5	35	28	25.5	0.5	15	1.4
	KF	16.5	35	30	25.5	0.5	15	1.4
32	GF	16.5	35	28	25.5	0.5	15	1.7
	KF	16.5	35	30	25.5	0.5	15	1.7
40	GF	16	35.7	29	32	0.5	21	1.6
	KF	16	35.7	35	37	0.5	21.5	2

For Ø		L1	L2	L3	L4	L5	L6	L7
[mm]			min.					
18	GF	128	14.5	107	80	118.5	23.5	69.5
	KF	128	14.5	107	80	118.5	23.5	69.5
25	GF	168	22.5	136	80	125	20.5	100
	KF	168	22.5	136	80	125	20.5	100
32	GF	206.8	42.8	164	120	165	14.5	124.8
	KF	206.8	27.3	164	120	165	14.5	124.8
40	GF	255	30.8	210	156	220.5	31	150
	KF	255	31	210	156	220.5	31	150

Passive guide axes DGC-FA, without drive

Accessories

Technical data and ordering codes

Adjustable end-position range

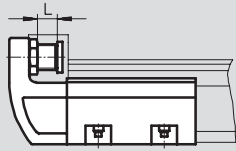

 Note

The stop KYC can be used in both directions.

Installation example

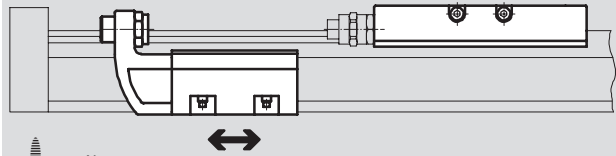

 Note

The end stop can be mounted at any position within the stroke.

For Ø [mm]	Adjustable end-position range L [mm]	Ambient temperature [°C]	CRC ¹⁾	Weight [g]	Part No.	Type
Shock absorber retainer						
18	GF	-10 ... +80	2	140	541 725	DADP-DGC-18-GF
	KF			130	541 729	DADP-DGC-18-KF
25	GF			205	541 726	DADP-DGC-25-GF
	KF			180	541 730	DADP-DGC-25-KF
32	GF			225	541 727	DADP-DGC-32-GF
	KF			215	541 731	DADP-DGC-32-KF
40	GF			380	541 728	DADP-DGC-40-GF
	KF			460	541 732	DADP-DGC-40-KF
Stop						
18	10	-10 ... +80	2	400	541 691	KYC-18
25	10			560	541 692	KYC-25
32	10			790	541 693	KYC-32
40	15			1,525	541 694	KYC-40



1) Corrosion resistance class 2 according to Festo standard 940 070

Components requiring moderate corrosion resistance. Externally visible parts with primarily decorative surface requirements which are in direct contact with a normal industrial environment or media such as coolants or lubricating agents.

Passive guide axes DGC-FA, without drive

Accessories

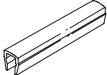
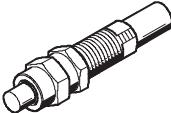

Ordering data				Technical data → Volume 1		
	For Ø	Remarks	Order code	Part No.	Type	PU ¹⁾
Slot nut NST						
	25 ... 40	For mounting slot	B	547 264	HMBN-5-1M5	1
Centring pin/sleeve ZBS/ZBH						
	8 ... 18	For slide	-	150 928	ZBS-5	10
	25 ... 40			150 927	ZBH-9	
	8, 12	For end cap	-	525 273	ZBS-2	
	18			150 928	ZBS-5	
	25 ... 40			150 927	ZBH-9	
Slot cover ABP-S						
	18 ... 40	For sensor slot each 0.5 m	L	151 680	ABP-5-S	2
Shock absorber						
	8, 12	For DGC basic design	YSRW	540 344	YSRW-DGC-8	1
	18 ... 40	For DGC with plain-bearing guide		540 345	YSRW-DGC-12	
				540 346	YSRW-DGC-18-GF	
				540 348	YSRW-DGC-25-GF	
				540 350	YSRW-DGC-32-GF	
				540 352	YSRW-DGC-40-GF	
	18 ... 40	For DGC with recirculating ball bearing guide		540 347	YSRW-DGC-18-KF	
				540 349	YSRW-DGC-25-KF	
				540 351	YSRW-DGC-32-KF	
540 353			YSRW-DGC-40-KF			

1) Packaging unit quantity

Passive guide axes FDG-ZR-RF, without drive

Peripherals overview



System components
Passive guide axes

3.1

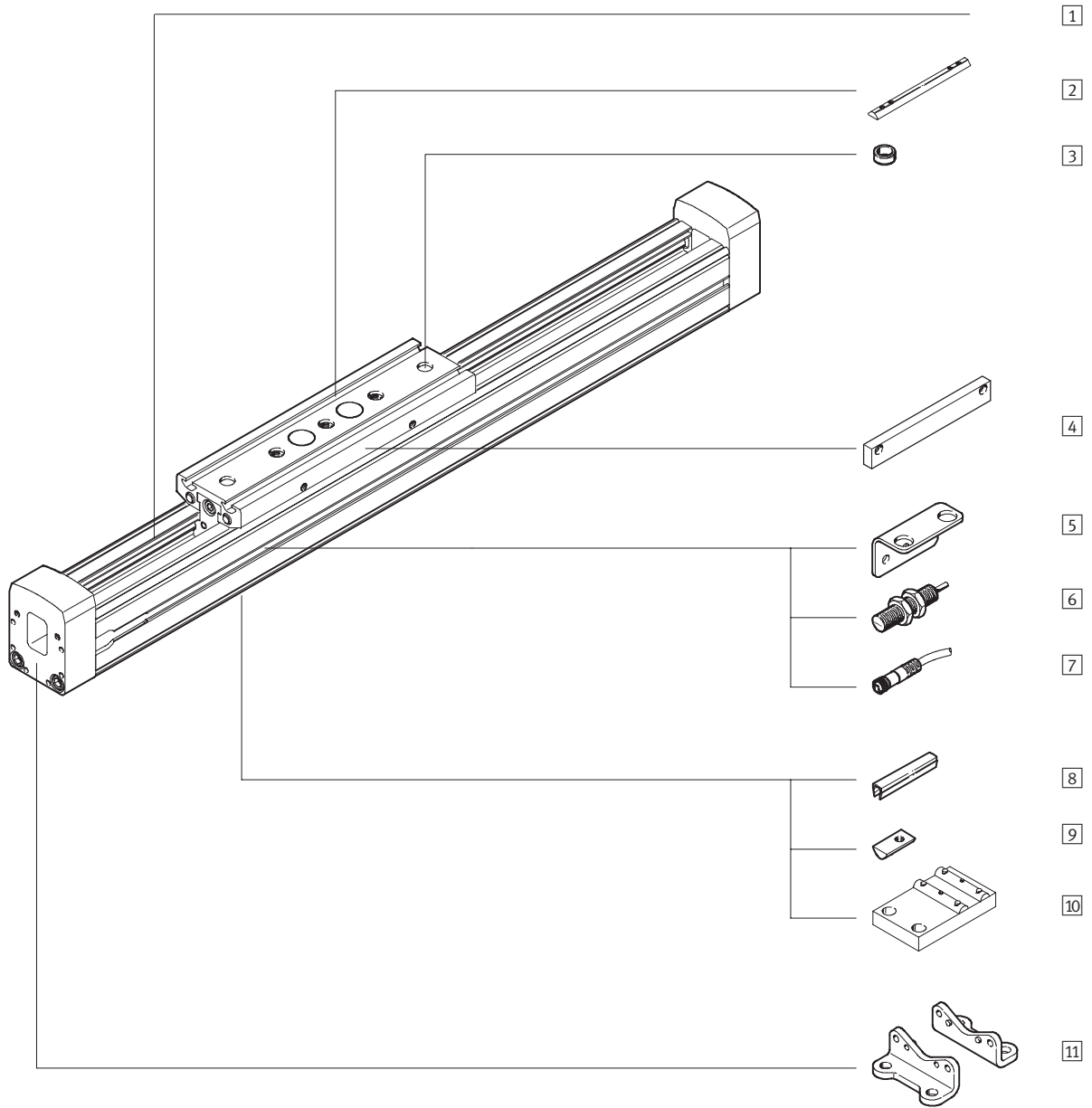

Passive guide axes FDG-ZR-RF, without drive

Peripherals overview

FESTO

Variants and accessories		
Type	Brief description	→ Page
1 Passive guide axis FDG-ZR-RF	Guide without drive	5 / 3.1-30
2 Slot nut for slide X	For mounting loads and attachments on the slide	5 / 3.1-39
3 Centring sleeve Z	For centring loads and attachments on the slide	5 / 3.1-39
4 Switching lug L	For sensing the slide position	5 / 3.1-40
5 Mounting bracket T	Adapter for mounting the sensors on the axis	5 / 3.1-40
6 Inductive proximity sensor O/P/W/R	For use as a proximity signal and safety monitor	5 / 3.1-41
7 Plug socket with cable V	For proximity sensors	5 / 3.1-41
8 Slot cover B	For protecting against ingress of dirt	5 / 3.1-39
9 Slot nut for profile slot Y	For mounting attachments	5 / 3.1-39
10 Central support M	For mounting the axis	5 / 3.1-38
11 Foot mounting F	For mounting the axis	5 / 3.1-38

Passive guide axes FDG-ZR-RF, without drive

Type codes



System components
Passive guide axes

3.1

	FDG	-	25	-	500	-	ZR	-	RF	-	GK
Type											
FDG	Guide unit without drive										
Size											
Stroke [mm]											
Guide axis											
ZR	For toothed belt axis DGE-ZR-RF										
Guide											
RF	Roller guide										
Slide											
GK	Standard slide										
GV	Extended slide										

Passive guide axes FDG-ZR-RF, without drive

Type codes

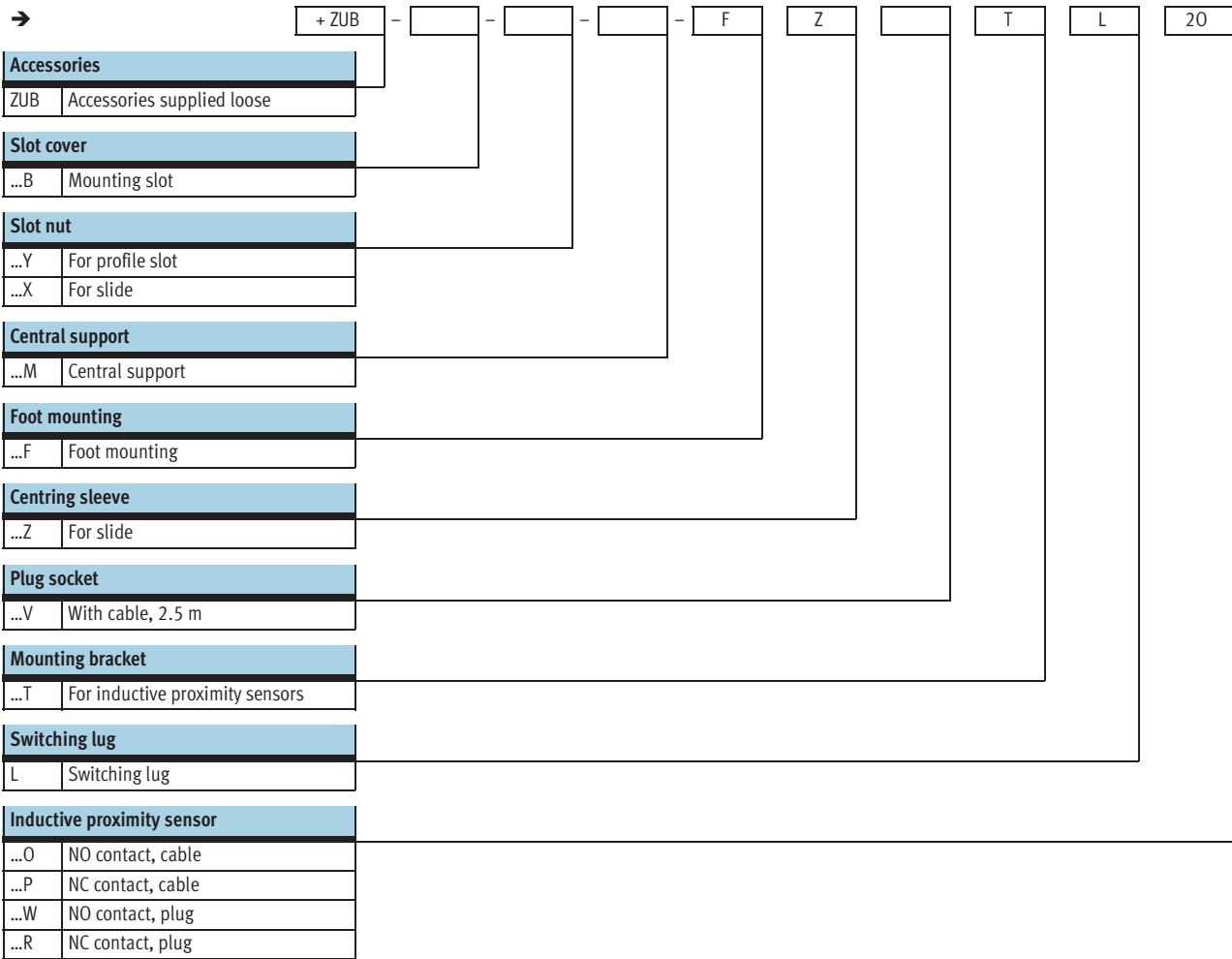

Passive guide axes FDG-ZR-RF, without drive

Technical data



- \varnothing - Size
25 ... 63
- | - Stroke length
1 ... 5000 mm

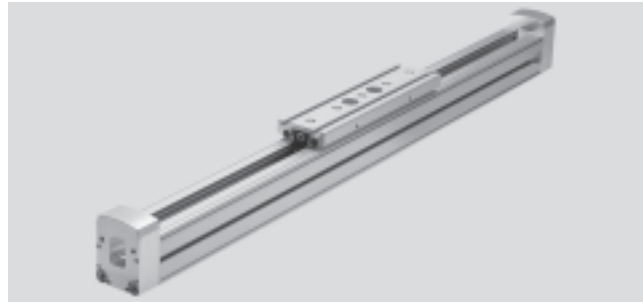

General technical data			
Size	25	40	63
Design	Guide unit without drive		
Guide	Internal roller guide		
Assembly position	Any		
Max. working stroke ¹⁾	[mm] 1 ... 5000	1 ... 5000	1 ... 5000 ²⁾
Max. working load	[kg] 15	30	60
Thrust	[N] 5 ... 12	5 ... 35	5 ... 30
Max. speed	[m/s] 10		
Max. acceleration	[m/s ²] 50		
Ambient temperature	[°C] 0 ... +60		

- 1) Total stroke = working stroke + 2x stroke reserve
- 2) The max. working stroke for the variant with extended slide (GV) is 4,800 mm.

Weights [kg]						
Size	25		40		63	
	GK	GV	GK	GV	GK	GV
Basic weight with 0 mm stroke	2.0	2.5	6.1	7.6	20.4	25.4
Additional weight per 100 mm stroke	0.29		0.59		1.38	
Moving load	0.5	0.8	1.8	2.5	4.6	6.4

Materials

Sectional view

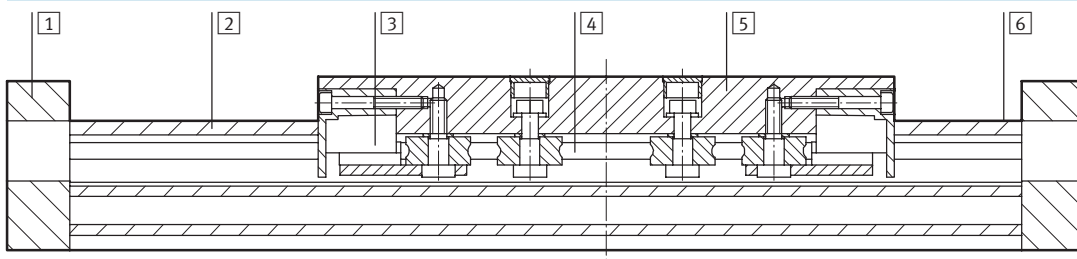

Axis	
1	End cap Anodised aluminium
2	Housing Anodised aluminium
3	Cover cap Polyamide
4	Guide rail Steel
5	Slide Anodised aluminium
6	Guide element Steel
-	Note on materials Free of copper, PTFE and silicone

Passive guide axes FDG-ZR-RF, without drive

Technical data

Stroke reserve

L9 The stroke reserve is a safety distance available on both sides of the axis in addition to the stroke.
The indicated values only apply in combination with the toothed belt axis DGE-ZR-RF.

L6 Slide length

L8 Stop element

L1+ Overall length of axis

1 Working stroke

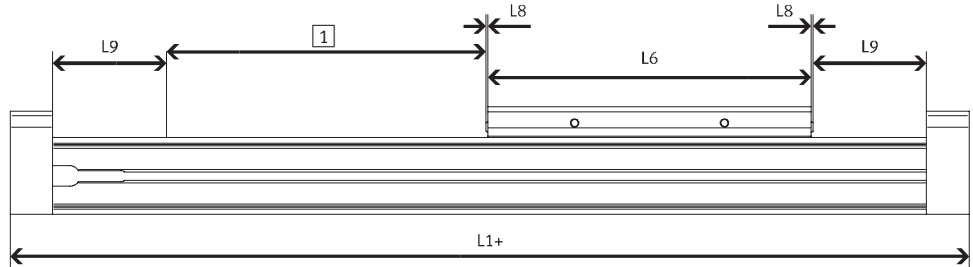

Example:

Type FDG-25-500-ZR-RF

Working stroke = 500 mm

Stroke reserve = (2x 86 mm)

= 172 mm

Total stroke = 500 mm + 172 mm

= 672 mm

Size	25	40	63
L9 per end position [mm]	86	136	244

Passive guide axes FDG-ZR-RF, without drive

Technical data



Characteristic load values

The indicated forces and torques refer to the centre of the guide. They must not be exceeded in the dynamic range. Special attention must be paid to the cushioning phase.

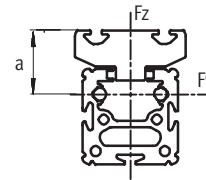
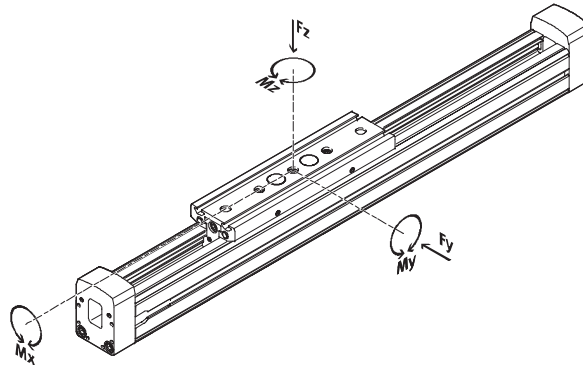

Size	a in [mm]
25	30
40	37
63	44.6

If the drive is subjected to more than two of the indicated forces and torques simultaneously, the following equations must be satisfied in addition to the indicated maximum loads:

$$\frac{F_y}{F_{y_{max}}} + \frac{F_z}{F_{z_{max}}} + \frac{M_x}{M_{x_{max}}} + \frac{M_y}{M_{y_{max}}} + \frac{M_z}{M_{z_{max}}} \leq 1$$

Permissible forces and torques

Size	25		40		63	
	GK	GV	GK	GV	GK	GV
F _y _{max.} [N]	150		300		600	
F _z _{max.} [N]	150		300		600	
M _x _{max.} [Nm]	7		18		65	
M _y _{max.} [Nm]	15	30	60	120	170	340
M _z _{max.} [Nm]	15	30	90	180	300	600

2nd moment of area

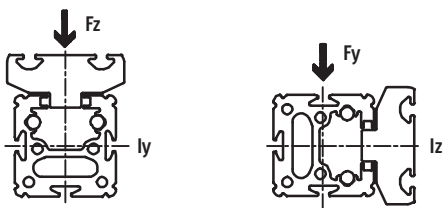

Size	25	40	63
I _y [mm ⁴]	5.947x10 ⁵	2.479x10 ⁶	1.664x10 ⁷
I _z [mm ⁴]	2.372x10 ⁵	9.463x10 ⁵	5.997x10 ⁶

PtTool
design tool
www.festo.com/en/engineering

Passive guide axes FDG-ZR-RF, without drive

Technical data



Maximum permissible support span l as a function of the applied load m

The axis may need to be supported with central supports MUP in order to limit deflection in the case of large strokes. The following diagrams serve

to determine the maximum permissible support span as a function of the applied load acting upon the axis.

A distinction is made here between forces acting upon the surface of the slide and forces acting upon the front of the slide.

1 Load on the surface of the slide

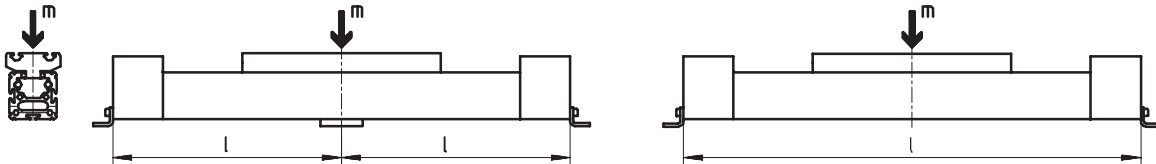

2 Load on the front of the slide

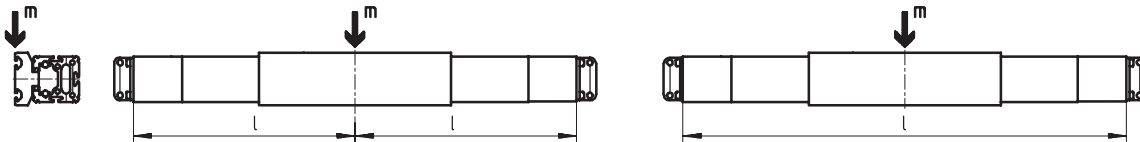

Maximum support span l (without central support) as a function of the applied load m

FDG-25

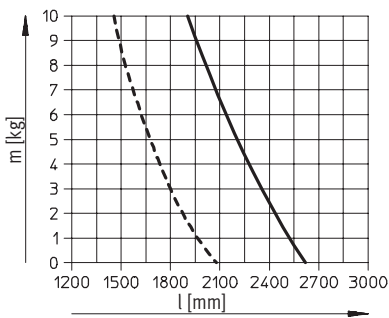

FDG-40

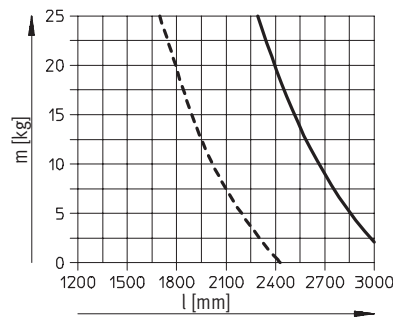

FDG-63

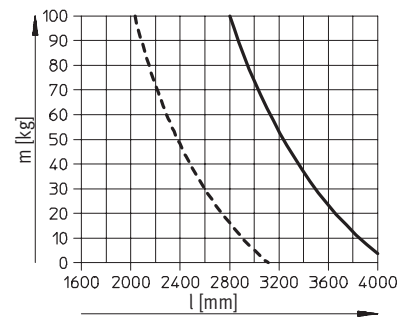

- 1
- - - 2

Passive guide axes FDG-ZR-RF, without drive

Technical data



Dimensions

Download CAD data → www.festo.com/en/engineering

FDG-25/-40/-63

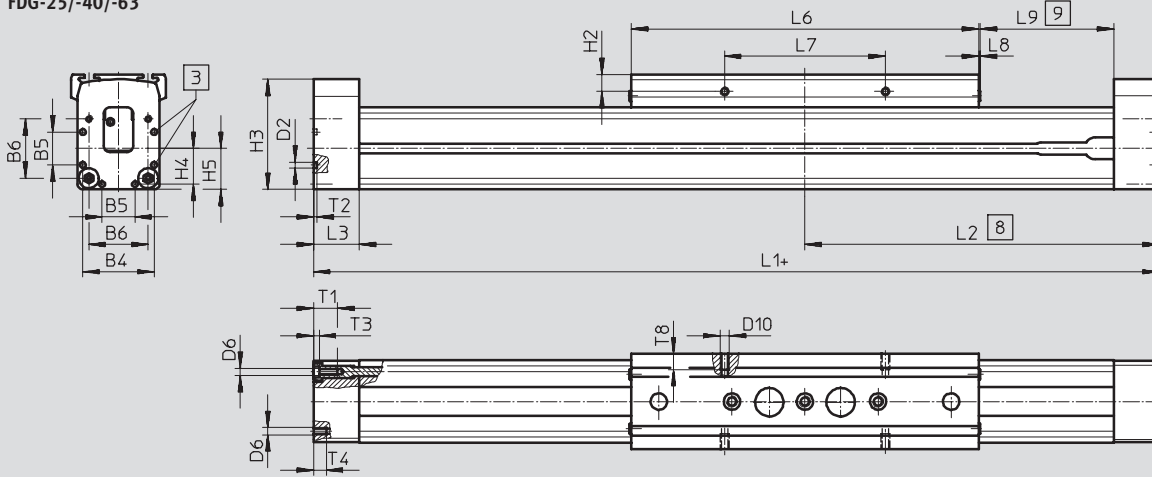

- 3 Centring hole for foot mounting
- 8 Driver in end position of the working stroke (including L9)
- 9 Recommended stroke reserve
- + = plus stroke length

FDG-25

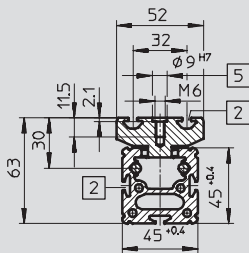

- 2 Slot for slot nuts
- 5 Hole for centring sleeve ZBH-9 and mounting thread

FDG-40

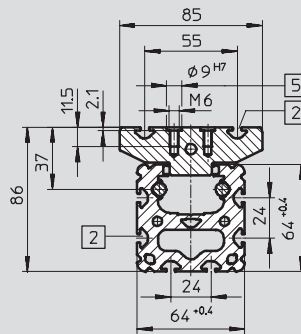

FDG-63

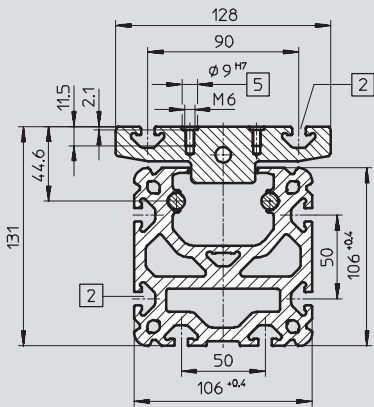

FDG-25-GK

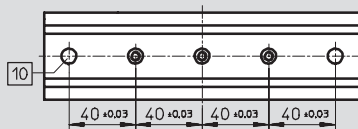

FDG-40-GK

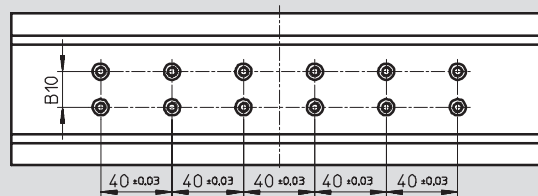

FDG-25-GV

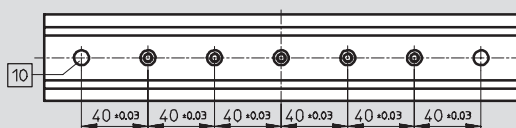

FDG-40-GV, FDG-63-GK

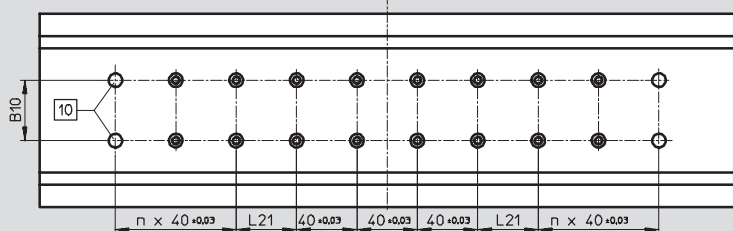

- 10 Hole for centring sleeve ZBH-9

Passive guide axes FDG-ZR-RF, without drive

Technical data



FDG-63-GV

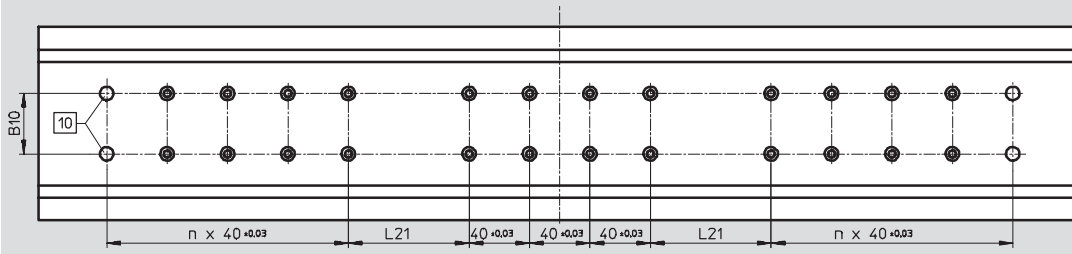

Size		B4	B5	B6	B10 ±0.03	D2	D6	D10	H2	H3
25	GK	39.1	18	32.5	-	3.3 _{+0.1}	M4	M5	9.3	60.4
	GV									
40	GK	53	28	49	20	4.4 _{H13}	M5	M5	9.5	83.8
	GV									
63	GK	89	44	83	40	6.4 _{+0.1}	M8	M8	10.5	129.3
	GV									

Size		H4	H5	L1	L2	L3	L6	L7	L8
25	GK	19.6	22.5	414	207	25	190	88 _{+0.2}	1
	GV			509	254.5		285		
40	GK	26.5	32	638	319	31	300	58 _{+0.1}	2
	GV			778	389		440		
63	GK	44.5	52.8	1020	510	34	460	72 _{+0.1}	2
	GV			1250	625		690		

Size		L9	L21 ±0.03	n	T1	T2	T3	T4	T8
25	GK	86	-	-	13	2	3	8	8.5
	GV								
40	GK	136	40	-	13	3	5	12	8.5
	GV			2					
63	GK	244	40	2	21	4	6	-	12
	GV			80					

Passive guide axes FDG-ZR-RF, without drive

Ordering data – Modular products



System components
Passive guide axes

3.1

Ordering code
Mandatory data

GK Standard slide

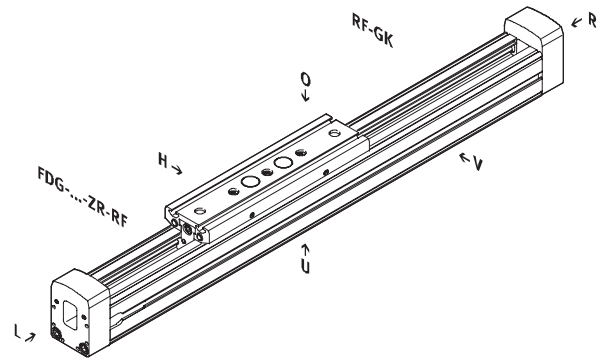

GV Extended slide

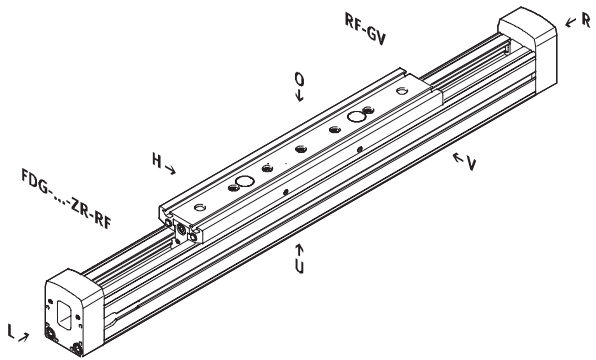

Ordering code
Options

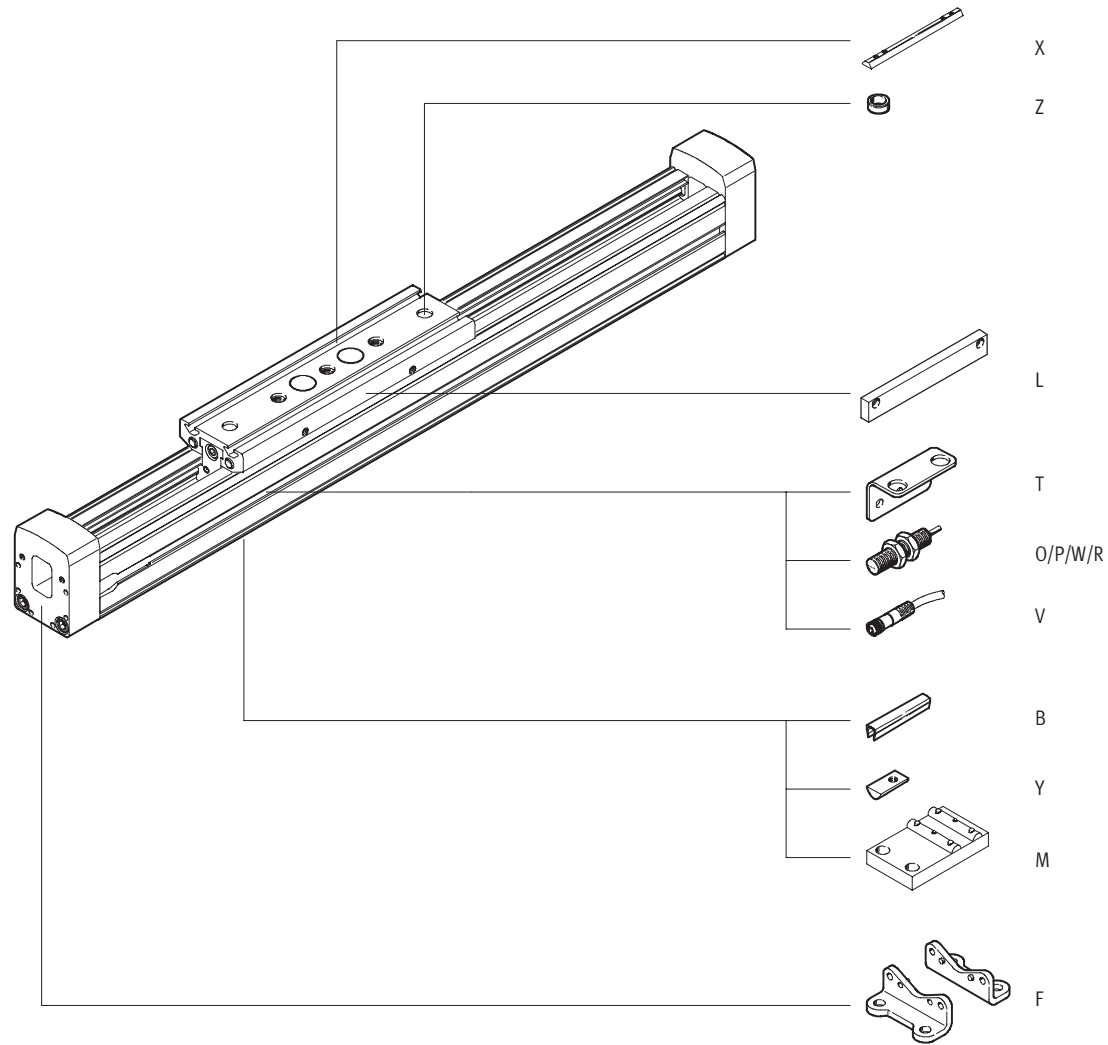

Passive guide axes FDG-ZR-RF, without drive



Ordering data – Modular products

M Mandatory data							O Options	
Module No.	Function	Size	Stroke	Guide axis	Guide	Slide	Accessories	
538 791	FDG	25	1 ... 5 000	ZR	RF	GK	...B, ...Y, ...X, ...M, ...F, ...Z, ...V, ...T, L, ...O, ...P, ...W, ...R	
538 792		40				GV		
538 793		63						
Ordering example								
538 791	FDG	- 25	- 300	- ZR	- RF	- GK	- ZUB	- 2B

Ordering table							
Size	25	40	63	Condi- tions	Code	Enter code	
M Module No.	538 791	538 792	538 793				
Function	Guide axis without drive				FDG		FDG
Size	25	40	63		-...		
Stroke [mm]	1 ... 5 000				-...		
Guide axis	for DGE-ZR-RF				-ZR		-ZR
Guide	Roller guide				-RF		-RF
Slide	Standard slide				-GK		
	Extended slide			1	-GV		
O Accessories	Accessories supplied loose				-ZUB-		-ZUB-
Slot cover for mounting slot	1 ... 10				...B		
Slot nut	Mounting slot	1 ... 10			...Y		
	For slide	1 ... 10			...X		
Central support	1 ... 10				...M		
Foot mounting	1 ... 10				...F		
Centring sleeve (pack of 10)	10, 20, 30, 40, 50, 60, 70, 80, 90				...Z		
Plug socket with cable, M8, 2.5 m	1 ... 10				...V		
Mounting bracket for inductive proximity sensors	1 ... 5				...T		
Switching lug	1				L		
Inductive proximity sensor	NO contact, cable 2.5 m	1 ... 5			...O		
	NC cable, cable 2.5 m	1 ... 5			...P		
	NO contact, plug M8	1 ... 5			...W		
	NC contact, plug M8	1 ... 5			...R		

1 GV Maximum stroke Size 25: 4 905 mm
Size 40: 4 860 mm
Size 63: 4 770 mm

Passive guide axes FDG-ZR-RF, without drive

Accessories



Foot mounting HP
(order code: F)

Material:
Galvanised steel
Free of copper, PTFE and silicone

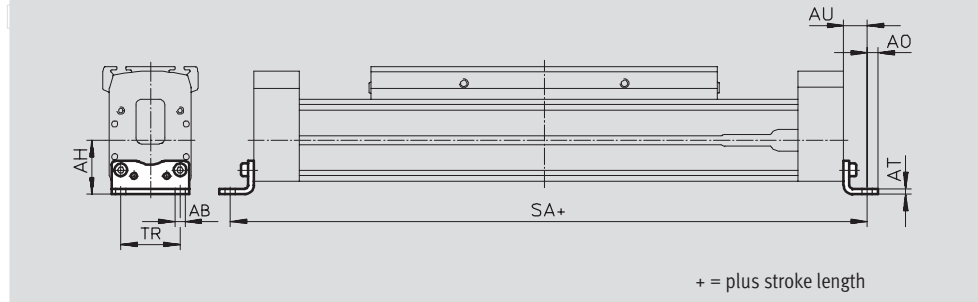

Dimensions and ordering data					
for size	AB Ø	AH	AO	AT	AU
25	5.5	29.5	6	3	13
40	6.6	46	8.5	5	17.5
63	11	69	13.5	6	28

for size	SA		TR	Weight [g]	Part No.	Type
	GK	GV				
25	440	535	32.5	61	150 731	HP-25
40	673	813	45	188	150 733	HP-40
63	1076	1306	75	305	150 735	HP-63

Central support MUP
(order code: M)

Material:
Galvanised steel
Free of copper, PTFE and silicone

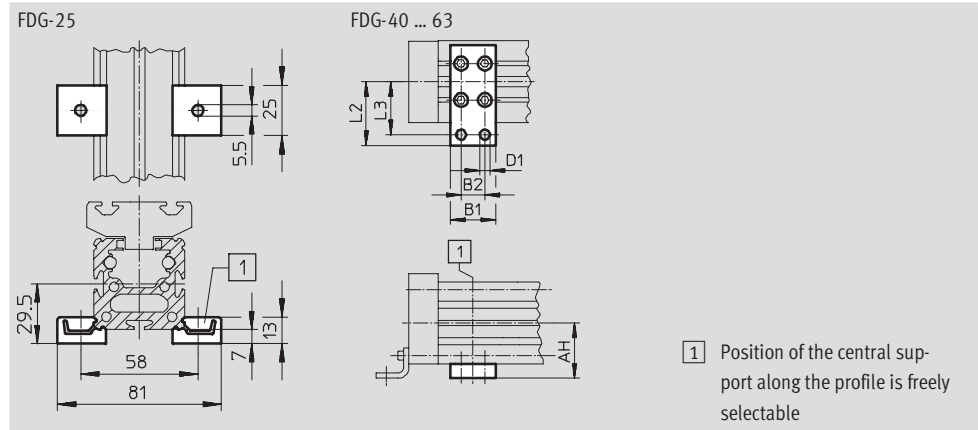



Dimensions and ordering data									
for size	AH	B1	B2	D1 Ø	L2	L3	Weight [g]	Part No.	Type
25	-	-	-	-	-	-	33	150 736	MUP-18/25
40	46	35	22	6.6	47	40	126	150 738	MUP-40
63	69	50	26	11	77	65	340	150 800	MUP-63

Passive guide axes FDG-ZR-RF, without drive

Accessories

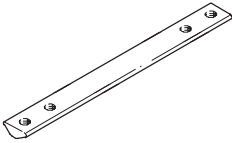

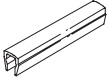
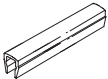
Ordering data				Technical data → Volume 1		
	for size	Remarks	Ordering code	Part No.	Type	PU ¹⁾
Slot nut NST						
	25	For mounting slot/profile slot	Y	526 091	NST-HMV-M4	1
	40			150 914	NST-5-M5	1
	63			150 915	NST-8-M6	1
Slot nut NSTL						
	25	For slide	X	158 410	NSTL-25	1
	40			158 412	NSTL-40	1
	63			158 414	NSTL-63	1
Centring pin/sleeve ZBH						
	25, 40, 63	For slide	Z	150 927	ZBH-9	10
Slot cover ABP-S						
	25	For mounting slot every 0.5 m	B	151 680	ABP-5-S	2
Slot cover ABP						
	40	For mounting slot every 0.5 m	B	151 681	ABP-5	2
	63			151 682	ABP-8	

1) Packaging unit quantity

Passive guide axes FDG-ZR-RF, without drive

Accessories



System components
Passive guide axes

Sensor bracket HWS

for inductive proximity sensors

(order code: T)

Material:

Galvanised steel



Switching lug SF

(order code: L)

Material:

Galvanised steel



FDG-25

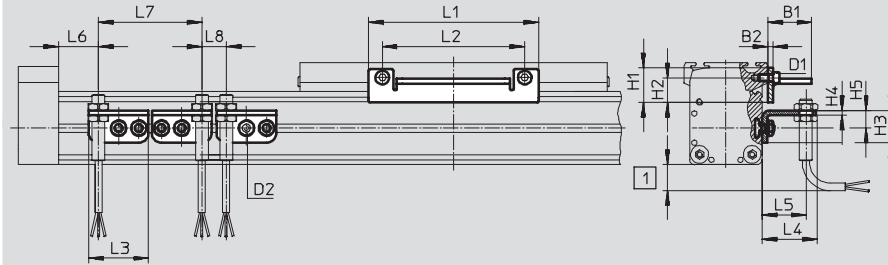

FDG-40 ... 63

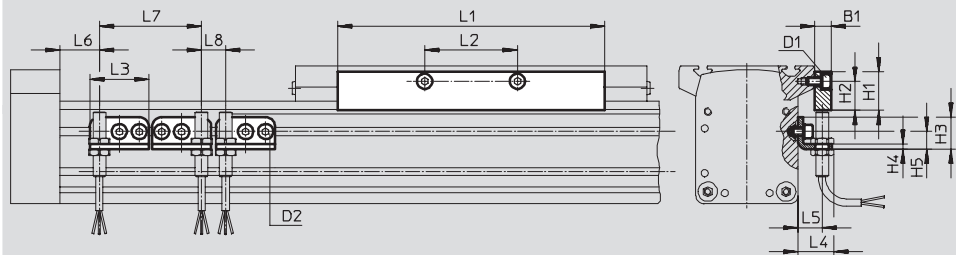

1 Protruding sensor cable, ensure sufficient installation space

Dimensions and ordering data





for size	D1	D2	B1	B2	H1	H2	H3	H4	H5	L1	L2	L3	L4	L5
25	M5	M5	27	3	20.5	15.3	20	3	11	105	88	37	34.5	27
40	M5	M5	10	-	24	18	20	3	11	167	58	37	22.5	15
63	M8	M5	10	-	35	25	20	3	11	230	72	37	22.5	15



for size	L6		L7	L8	Weight [g]	Part No.	Type
	GK	GV	min.	min.			
25	43.5	91	64	15	30	540 780	HWS-25-MAB-M8
					80	540 430	SF-25-MAB
40	68.5	138.5	64	15	40	188 969	HWS-40-M8
					310	188 966	SF-40
63	117	232	64	15	40	188 970	HWS-63-M8
					630	188 967	SF-63

Passive guide axes FDG-ZR-RF, without drive

Accessories



Ordering data – Inductive proximity sensors M8						Technical data → Volume 4	
	Electrical connection		Switch output	LED	Cable length [m]	Part No.	Type
	Cable	Plug M8					
NO contact							
	3-core	–	PNP	■	2.5	150 386	SIEN-M8B-PS-K-L
	–	3-pin	PNP	■		150 387	SIEN-M8B-PS-S-L
NC contact							
	3-core	–	PNP	■	2.5	150 390	SIEN-M8B-PO-K-L
	–	3-pin	PNP	■		150 391	SIEN-M8B-PO-S-L

Ordering data – Plug sockets with cable						Technical data → Volume 1	
	Assembly	Switch output		Connection	Cable length [m]	Part No.	Type
		PNP	NPN				
Straight socket							
	Union nut M8	■	■	3-pin	2.5	159 420	SIM-M8-3GD-2,5-PU
		■	■		5	159 421	SIM-M8-3GD-5-PU
Angled socket							
	Union nut M8	■	■	3-pin	2.5	159 422	SIM-M8-3WD-2,5-PU
		■	■		5	159 423	SIM-M8-3WD-5-PU

Passive guide axes FDG, without drive

Peripherals overview

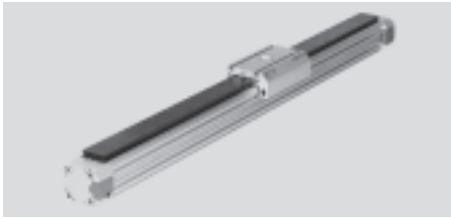

System components
Passive guide axes

3.1

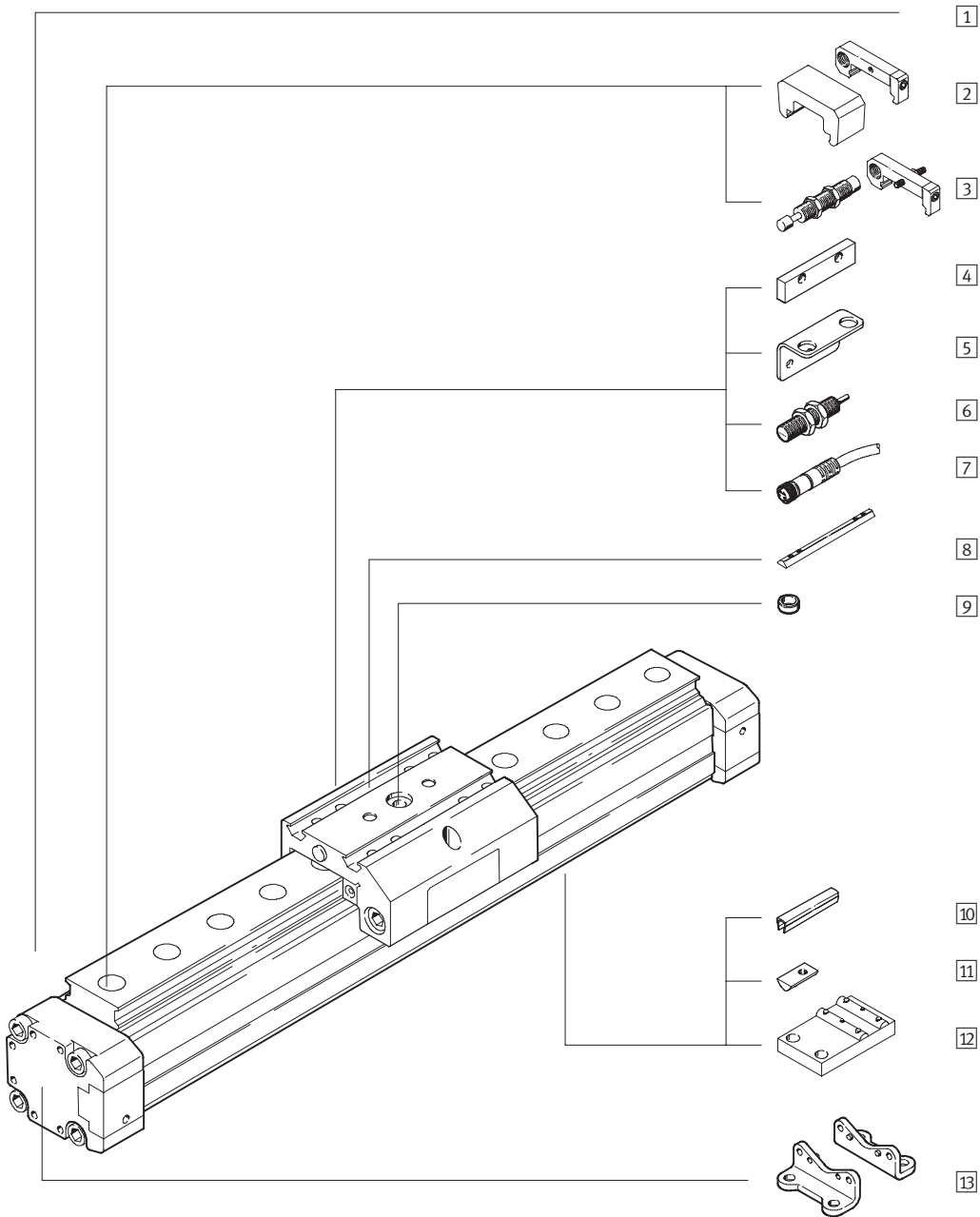

Passive guide axes FDG, without drive

Peripherals overview

FESTO

Variants and accessories		
Type	Brief description	→ Page
1 Passive guide axis FDG	Guide without drive	5 / 3.1-44
2 Emergency buffer with retainer A	Absorbs the energy created by the movement of the slide when it reaches the end position	5 / 3.1-60
3 Shock absorber kits C/E	Absorbs the energy created by the movement of the slide when it reaches the end position	5 / 3.1-59
4 Switching lug L	For sensing the slide position	5 / 3.1-61
5 Sensor bracket T	Adapter for mounting the SIEN proximity sensor on the axis	5 / 3.1-61
6 Proximity sensors O/P/R/W	For providing a proximity signal or safety check	5 / 3.1-63
7 Plug socket with cable V	For proximity sensor	5 / 3.1-63
8 Slot nut for slide X	For mounting loads and attachments on the slide	5 / 3.1-62
9 Centring sleeve Z	For centring loads and attachments on the slide	5 / 3.1-62
10 Slot cover B/S	To protect against the ingress of dirt	5 / 3.1-62
11 Slot nut for mounting slot Y	For mounting attachments	5 / 3.1-62
12 Central support M	To mount the axis	5 / 3.1-58
13 Foot mounting F	To mount the axis	5 / 3.1-58

Passive guide axes FDG, without drive

Type codes



		FDG	-	25	-	500	-	ZR	-	KF	-	GK	-	
Type														
FDG	Guide unit without drive													
Size														
Stroke [mm]														
Passive guide axis														
ZR	For toothed belt axis DGE-ZR-KF													
SP	For spindle drive DGE-SP-KF													
P	For pneumatic linear drive DGPL													
Guide														
KF	Recirculating ball bearing guide													
Slide														
GK	Standard slide													
GV	Extended slide													
GA	Protected version													
Additional slide														
KL	Left													
KR	Right													

Passive guide axes FDG, without drive

Type codes

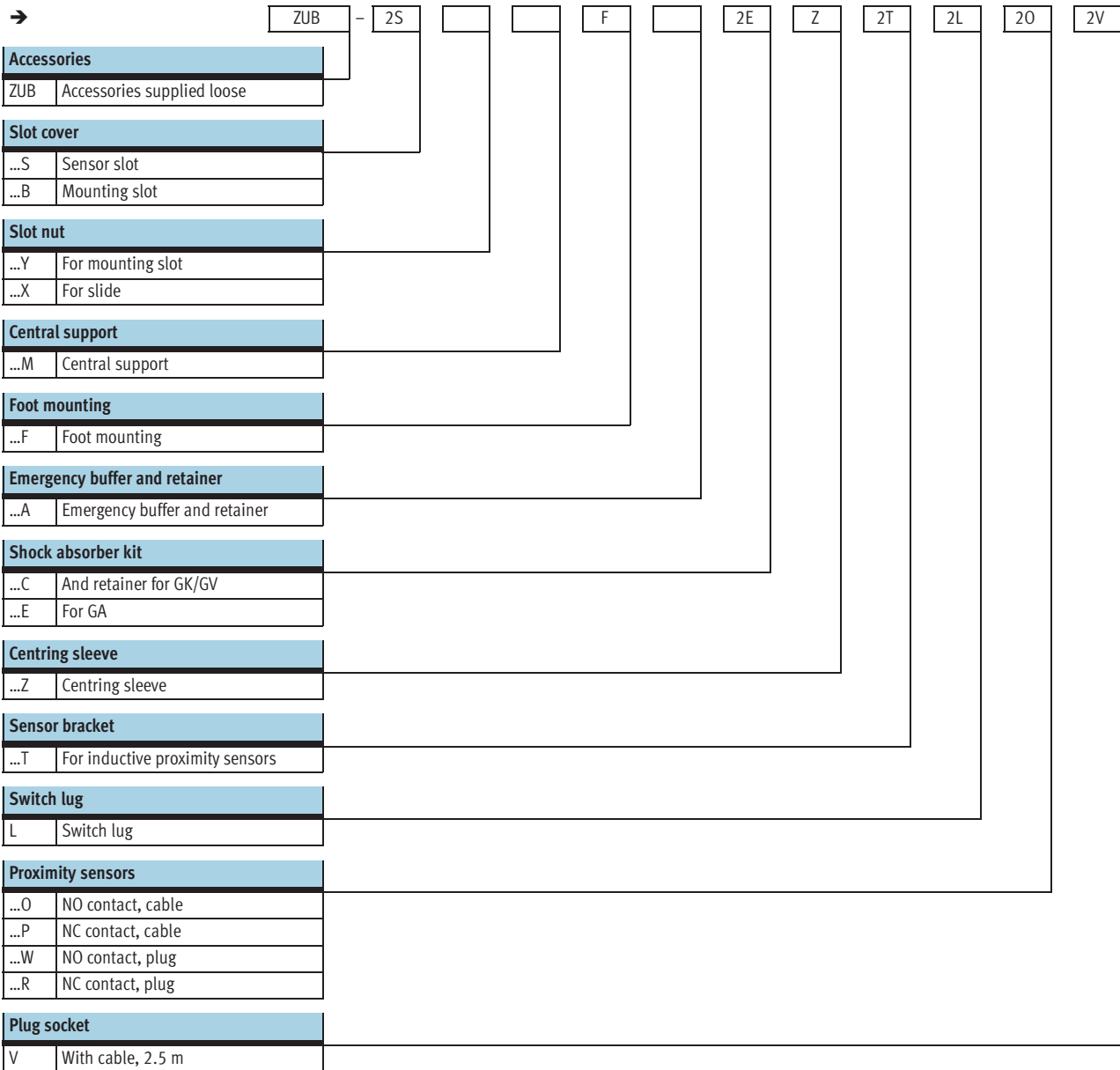

Passive guide axes FDG, without drive

Technical data



- - Size
18 ... 63
- - Stroke length
100 ... 5,100 mm

- - www.festo.com/en/Spare_parts_service

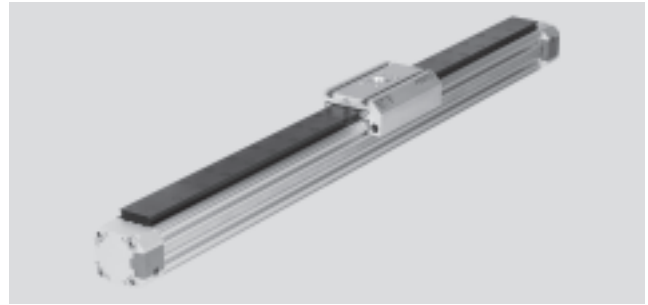

System components
Passive guide axes

3.1

General technical data			18	25	32	40	50	63
Size			18	25	32	40	50	63
Max. stroke	FDG-ZR	[mm]	1 ... 1,000	1 ... 5,100	–	1 ... 4,900	–	1 ... 4,700
	FDG-SP	[mm]	1 ... 500	1 ... 1,000	–	1 ... 1,500	–	1 ... 2,000
	FDG-P	[mm]	10 ... 1,800	10 ... 3,000	10 ... 3,000	10 ... 3,000	10 ... 3,000	10 ... 3,000
Design	Driveless linear guide unit with slide							
Guide	External recirculating ball bearing guide							
Fitting position	Any							
Cushioning	Not adjustable at either end							
	Self-adjusting at both ends							
Type of mounting	Profile mounting							
	Foot mounting							
	Direct mounting							
Increase in no-load drive torque	for DGE-...-ZR by	[Nm]	0.005	0.02	–	0.03	–	0.085
	for DGE-SP by	[Nm]	0.04	0.1	–	0.15	–	0.45
Thrust ¹⁾		[N]	5	10	7	9	12	16
Ambient temperature		[°C]	–10 ... +60					

1) Measured at FDG-18 = 0.05 m/s; FDG-25... 63 = 0.2m/s

Weights [kg]			18	25	32	40	50	63
FDG-ZR								
Basic weight at 0 mm stroke	GK		0.879	2.022	–	6.055	–	21.493
	GV		1.341	2.927	–	7.939	–	31.464
	GA		–	2.931	–	8.128	–	–
Additional weight per 100 mm stroke	GK		0.274	0.479	–	0.968	–	2.423
	GV		0.274	0.479	–	0.968	–	2.423
	GA		–	0.570	–	1.092	–	–
FDG-SP								
Basic weight at 0 mm stroke	GK		0.743	1.482	–	4.296	–	13.454
	GV		1.232	2.530	–	7.678	–	25.847
	GA		–	2.459	–	6.798	–	–
Additional weight per 100 mm stroke	GK		0.274	0.479	–	0.968	–	2.423
	GV		0.274	0.479	–	0.968	–	2.423
	GA		–	0.570	–	1.092	–	–
FDG-P								
Basic weight at 0 mm stroke	GK		0.685	1.416	2.449	4.160	8.445	13.328
	GV		1.147	2.321	3.784	6.961	13.491	23.3
	GA		–	2.211	3.282	5.989	–	–
Additional weight per 100 mm stroke	GK		0.274	0.479	0.705	0.968	1.8	2.423
	GV		0.274	0.479	0.705	0.968	1.8	2.423
	GA		–	0.570	0.808	1.092	–	–

Passive guide axes FDG, without drive

Technical data

Materials

Sectional view

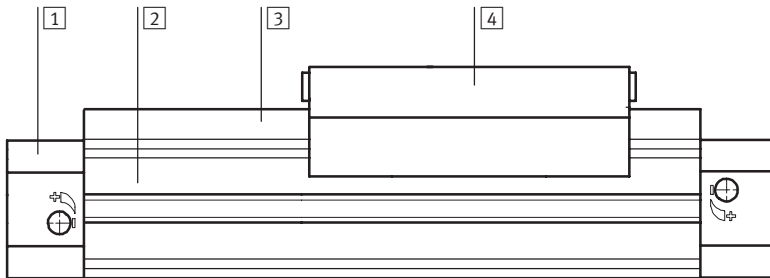

Axis

1	End cap	Anodised aluminium	
2	Profile	Anodised aluminium	
3	Guide rail	∅ 18	Hardened steel
		∅ 25 ... 63	Hardened steel with corrosion resistant coating
4	Slide	Anodised aluminium	
Note on material		Free of copper, PTFE and silicone	

Characteristic load values

The forces and torques specified refer to the centre of the guide rails. They must not be exceeded during dynamic operation. Special attention must be paid to the cushioning phase.

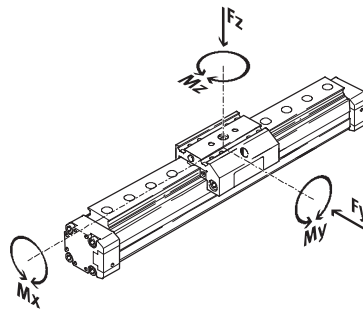

If the axis is simultaneously subjected to several of the forces and torques listed below, the following equations must be satisfied in addition to the indicated maximum loads.

$$\frac{F_y}{F_{y_{max}}} + \frac{F_z}{F_{z_{max}}} + \frac{M_x}{M_{x_{max}}} + \frac{M_y}{M_{y_{max}}} + \frac{M_z}{M_{z_{max}}} \leq 1$$

Permissible forces and torques

Size	18	25	32	40	50	63	
GK/GA – standard slide/protected slide							
F _y _{max.}	[N]	930	3,080	3,080	7,300	7,300	14,050
F _z _{max.}	[N]	930	3,080	3,080	7,300	7,300	14,050
M _x _{max.}	[Nm]	7	45	63	170	240	580
M _y _{max.}	[Nm]	23	85	127	330	460	910
M _z _{max.}	[Nm]	23	85	127	330	460	910
GV – extended slide							
F _y _{max.}	[N]	930	3,080	3,080	7,300	7,300	14,050
F _z _{max.}	[N]	930	3,080	3,080	7,300	7,300	14,050
M _x _{max.}	[Nm]	7	45	63	170	240	580
M _y _{max.}	[Nm]	45	170	250	660	920	1,820
M _z _{max.}	[Nm]	45	170	250	660	920	1,820

Passive guide axes FDG, without drive

Technical data



Maximum permissible support span l as a function of the force F

The axis may need to be supported with central supports MUP in order to limit deflection in the case of large strokes. The following diagrams serve to determine the maximum permissible support span l as a function of the force F .

Force on the surface of the slide

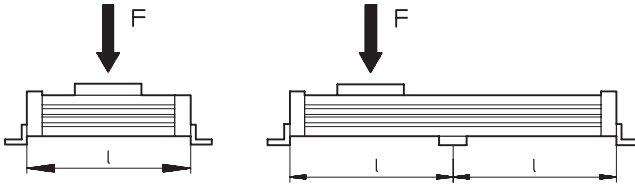

Maximum permissible support span l (without central support) as a function of the force F

Size 18...40

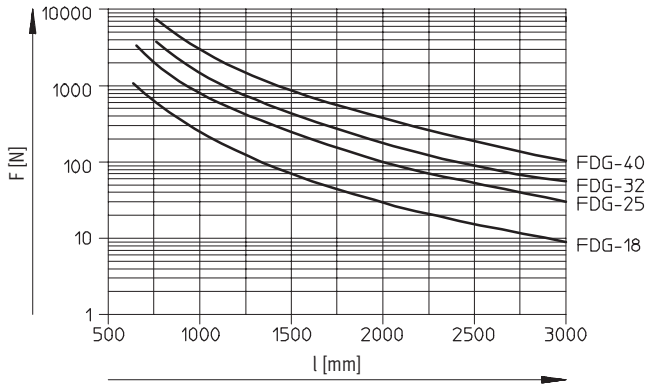

Size 50...63

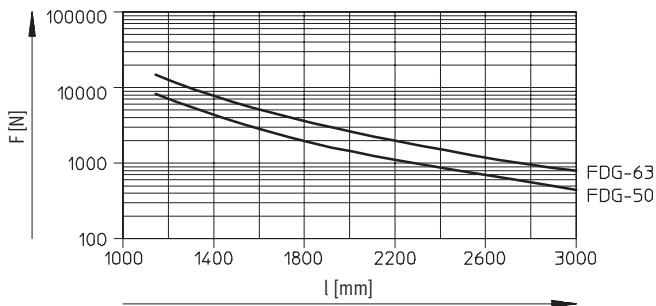

Passive guide axes FDG, without drive

Technical data

FESTO

Dimensions Download CAD data → www.festo.com/en/engineering

Standard slide GK

Size 18-...

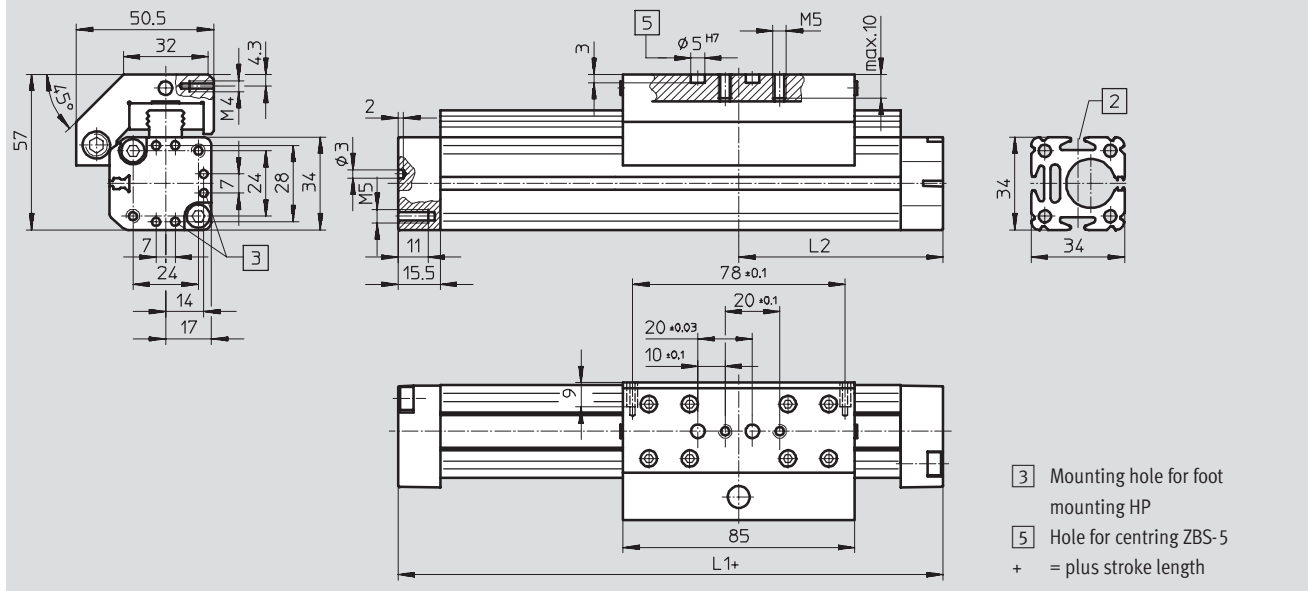

Extended slide GV

Size 18-P-GV

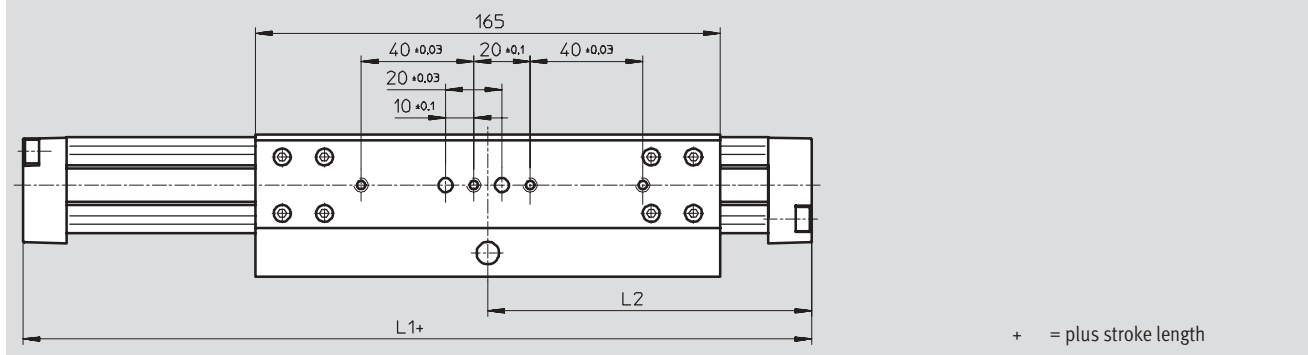

Extended slide GV

Size 18-ZR-/SP

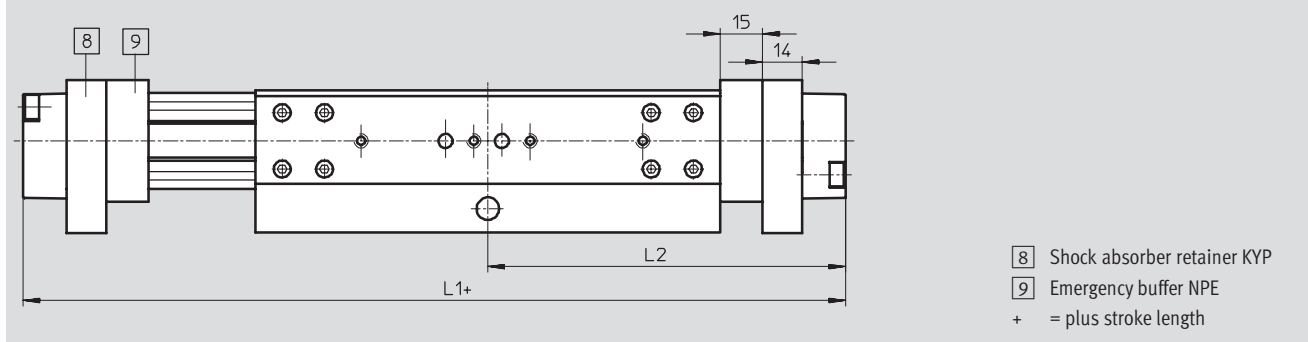

Size	L1		L2	
	GK	GV	GK	GV
FDG-18-...-P-...	150	230	75	115
FDG-18-...-ZR-...	221	301	110.5	150.5
FDG-18-...-SP-...	171	261	92	132

Passive guide axes FDG, without drive

Technical data



System components
Passive guide axes

3.1

Dimensions

Download CAD data → www.festo.com/en/engineering

Standard slide GK

Size 25-...

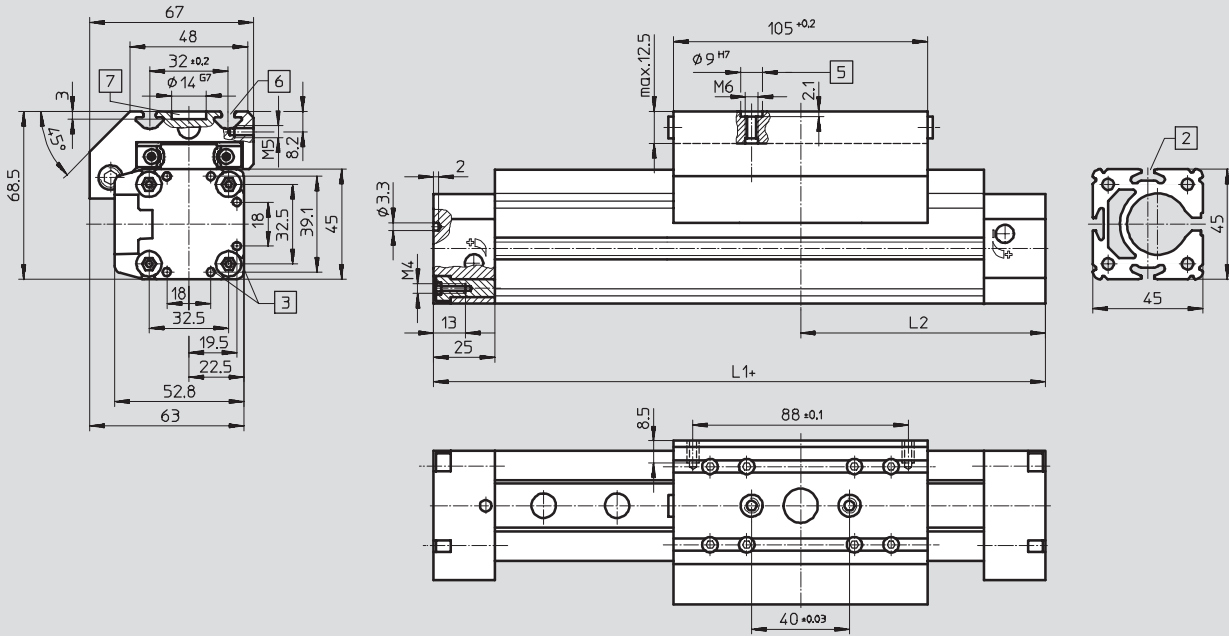

- 3 Mounting hole for foot mounting HP
 - 5 Hole for centring sleeve ZBH-9
 - 6 Mounting slot for slot nut NSTL
 - 7 Drilled hole for central mounting SLZZ
- + = plus stroke length

Extended slide GV

Size 25-P

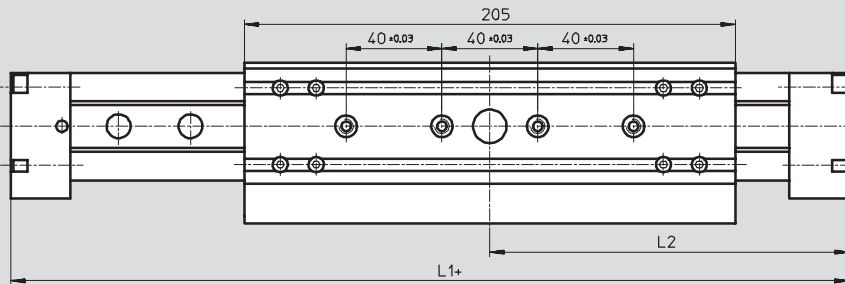

Extended slide GV

Size 25-ZR/-SP

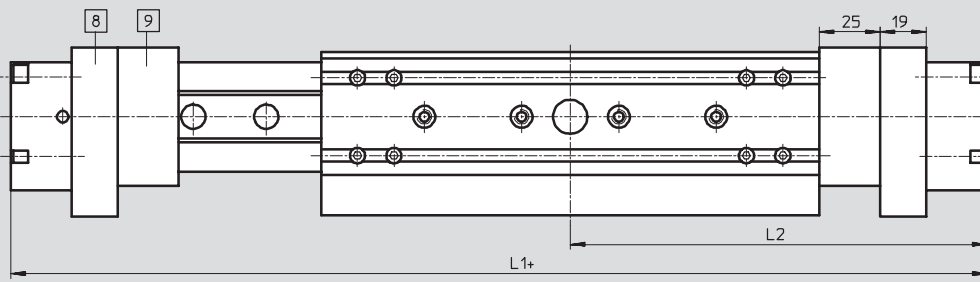

- 8 Shock absorber retainer KYP
 - 9 Emergency buffer NPE
- + = plus stroke length

Passive guide axes FDG, without drive

Technical data



Dimensions Download CAD data → www.festo.com/en/engineering

Protected version GA

Size 25-...GA

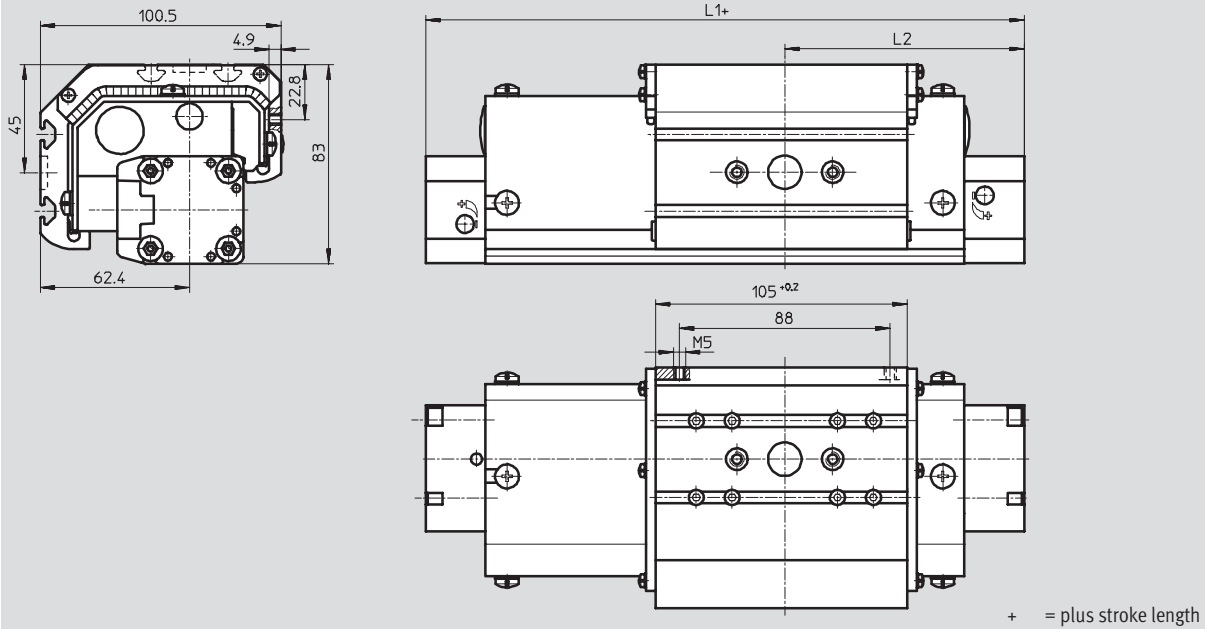

Size	L1			L2		
	GK	GV	GA	GK	GV	GA
FDG-25-...-P-...	200	300	200	100	150	100
FDG-25-...-ZR-...	326	426	326	163	213	163
FDG-25-...-SP-...	213	343	243	101.5	171.5	121.5

System components
Passive guide axes

3.1

Passive guide axes FDG, without drive

Technical data



Dimensions

Download CAD data → www.festo.com/en/engineering

Standard slide GK

Size 32...63-...

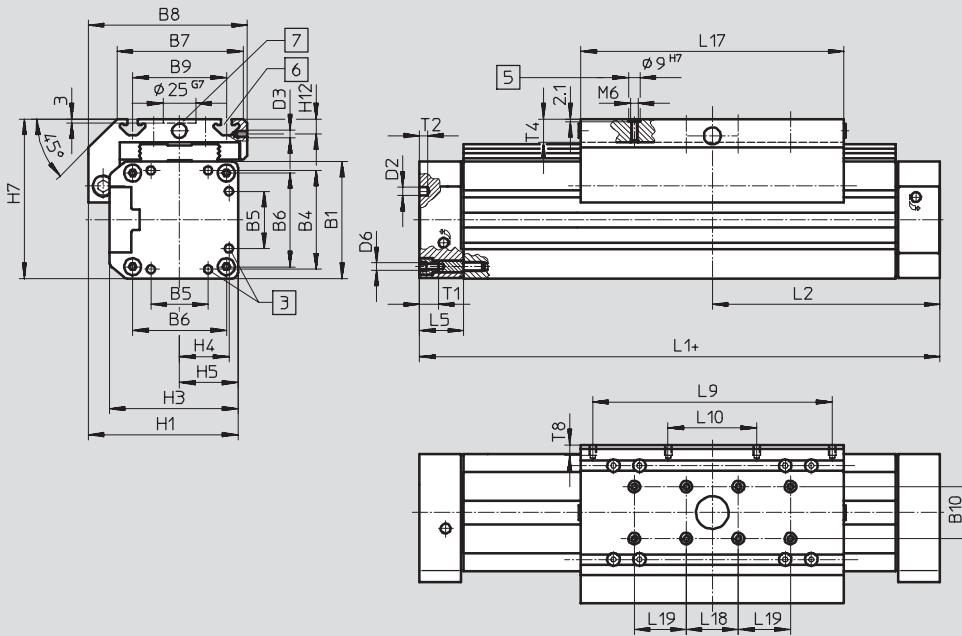

- 3 Mounting hole for foot mounting HP
- 5 Hole for centring sleeve ZBH-9
- 6 Mounting slot for slot nut NSTL
- 7 Drilled hole for central mounting SLZZ
- + = plus stroke length

Extended slide GV

Size 32...63-P

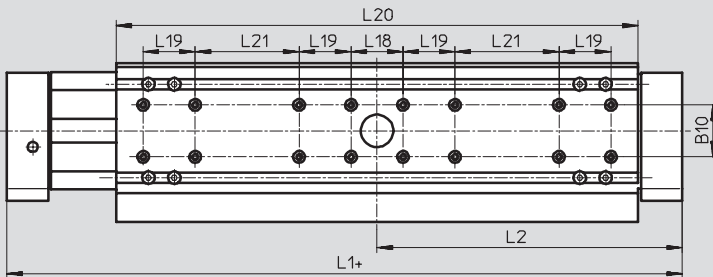

+ = plus stroke length

Extended slide GV

Size 40/63-ZR/-SP

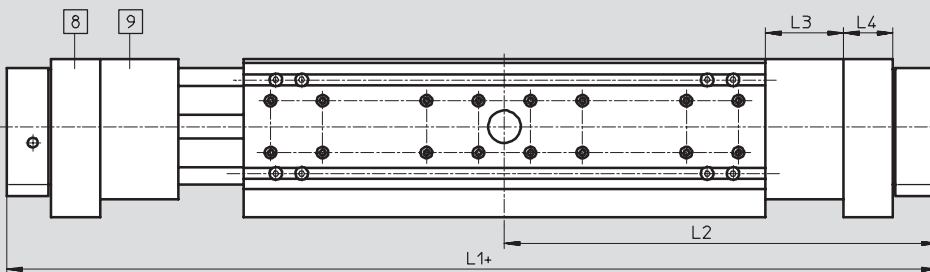

- 8 Shock absorber retainer KYP
- 9 Emergency buffer NPE
- + = plus stroke length

Profile barrel

Size 32

Size 40

Size 50

Size 63

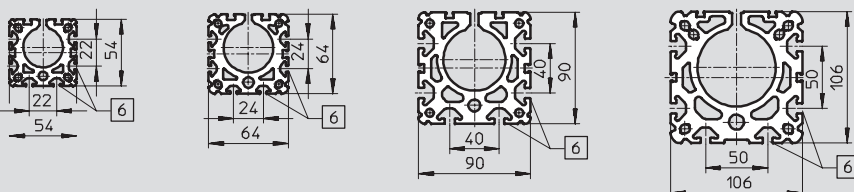

- 6 Mounting slot for slot nut NST

Passive guide axes FDG, without drive

Technical data



Dimensions Download CAD data → www.festo.com/en/engineering

Dust-proof version
Size 32/40-...GA

+ = plus stroke length

Size	L1			L2		
	GK	GV	GA	GK	GV	GA
FDG-32-...-P-...-	250	380	250	125	190	125
FDG-40-...-P-...-	300	470	300	150	235	150
FDG-50-...-P-...-	350	550	-	175	275	-
FDG-63-...-P-...-	400	650	-	200	325	-
FDG-40-...-ZR-...-	497	667	497	248.5	333.5	248.5
FDG-63-...-ZR-...-	738	988	-	369	494	-
FDG-40-...-SP-...-	315	545	375	153	271.5	186.5
FDG-63-...-SP-...-	406	756	-	198	378	-

Size	B1	B2	B3	B4	B5	B6	B7	B8	B9	B10	D2	D3
									±0.2		∅	
32	54	112.1	-	46	21	40	63	79	47	20	4.3	M5
40	64	137.6	7	53	28	49	78.5	96.5	55	20	4.3	M5
50	90	-	-	76	44	72	97	122	72	40	6.3	M6
63	106	-	-	89	44	83	121	142	90	40	6.3	M8

Size	D6	H1	H2	H3	H4	H5	H7	H8	H9	H10	H11	H12	L3
32	M5	72	66	62	23	27	77.5	93.1	49.5	64.5	-	8.3	-
40	M5	86	78	71.8	26.5	32	90.5	106.6	54	79.6	23.1	7	40
50	M6	115	106	99	36	45	122.5	-	-	-	-	11.5	-
63	M8	131	122	115	44.5	53	144.5	-	-	-	39.5	12.5	63

Size	L4	L5	L9	L10	L17	L18	L19	L20	L21	T1	T2	T4	T8
			±0.1	±0.1	±0.2	±0.03	±0.03		±0.1				
32	-	31	112	-	131	40	-	261	40	13.2	3	12.5	8.5
40	32	31	150	58	167	40	40	337	40	13.2	4	12.5	8.5
50	-	34	184	68	202	40	40	402	80	15.2	6	18.5	8
63	44	34	200	72	230	40	40	480	120	21.2	6	20.5	10.5

Passive guide axes FDG, without drive

Ordering data – Modular product system



Order code

Mandatory data/Options

Standard slide GK

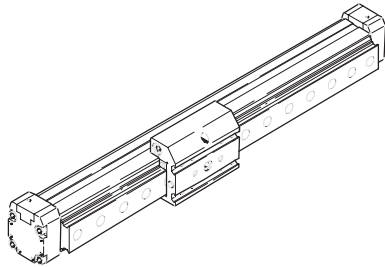

Standard slide plus additional slide GK-KL/-KR

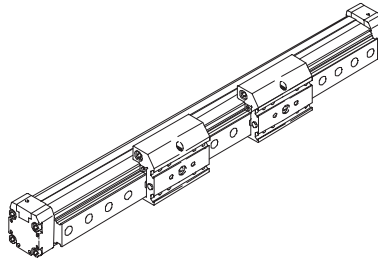

Extended slide GV

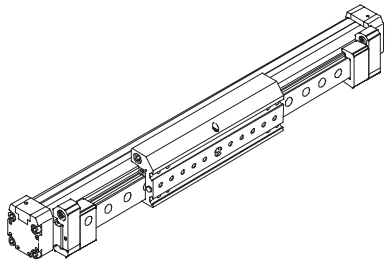

Extended slide plus additional slide GK-KL/-KR

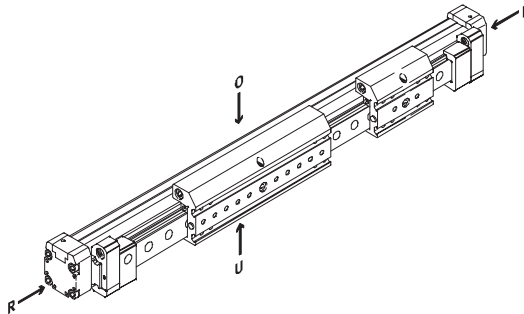

Dust-proof version GA

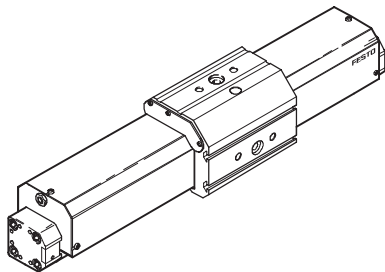

-  - Note
O = top
R = right
U = underneath
L = left

Passive guide axes FDG, without drive

Ordering data – Modular product system

Order code

Options

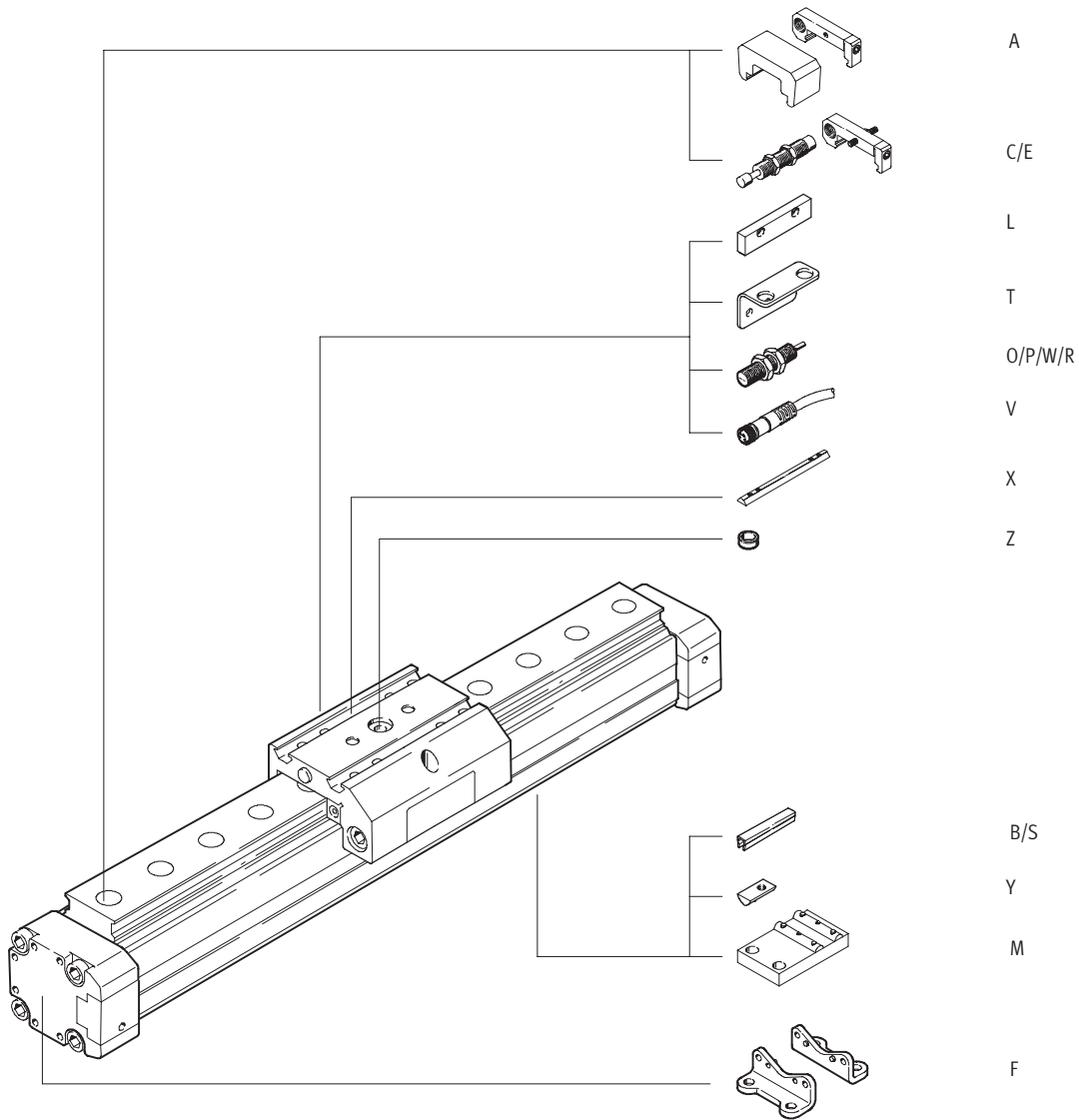

Passive guide axes FDG, without drive

Ordering data – Modular product system



M Mandatory data							O Options →
Module No.	Drive function	Size	Stroke	Passive guide axis	Guide	Slide	Additional slide
192 850	FDG	18	1 ... 5 100	ZR	KF	GK	KL
192 851		25		SP		GV	
192 852		32		P		GA	
192 853		40					
192 854		50					
192 855		63					
Ordering example							
192 853	FDG	- 40	- 500	- ZR	- KF	- GK	-

Ordering table										
Size	18	25	32	40	50	63	Condi- tions	Code	Enter code	
M Module No.	192 850	192 851	192 852	192 853	192 854	192 855				
Drive function	Guide unit without drive								FDG	FDG
Size	18	25	32	40	50	63		-...		
Stroke [mm] (as for corresponding drive axis)	with ZR	1 ... 1 000	1 ... 1 100	-	1 ... 4 900	-	1 ... 4 700		-...	
	with SP	1 ... 500	1 ... 1 000	-	1 ... 1 500	-	1 ... 2 000			
	with P	10 ... 1 800	10 ... 3 000	10 ... 3 000	10 ... 3 000	10 ... 3 000	10 ... 3 000			
Passive guide axis	for	DGE-ZR	DGE-ZR	-	DGE-ZR	-	DGE-ZR		-ZR	
	for	DGE-SP	DGE-SP	-	DGE-SP	-	DGE-SP		-SP	
	for	DGP	DGP	DGP	DGP	DGP	DGP		-P	
Guide	Recirculating ball bearing guide								-KF	-KF
Slide	Standard								-GK	
	Extended								-GV	
	Maximum stroke [mm]									
	with ZR	(920)	(5 000)	-	(4 730)	-	(4 450)			
	with SP	(410)	(870)	-	(1 270)	-	(1 650)			
	Protected version									
	Maximum stroke [mm]									
with ZR	-	(1 800)	-	(1 800)	-	-				
with SP	-	(970)	-	(1 440)	-	-				
with P	-	(2 000)	(2 000)	(2 000)	-	-				
O Additional slide	Standard slide left								[2]	-KL
↓	Standard slide right								[2]	-KR

[1] GA Not with accessories T, L, O, P, W, R.

[2] KL, KR Only with slide GK or GV.

Transfer order code

	FDG	-		-		-	KF	-		-	
--	-----	---	--	---	--	---	----	---	--	---	--

Passive guide axes FDG, without drive

Ordering data – Modular product system



Options											
Accessories	Slot cover	Slot nut	Central support	Foot mounting	Emergency buffer and retainer	Shock absorber	Centring sleeve	Sensor bracket	Switching lug	Proximity sensors	Plug socket
ZUB	...S ...B	...Y ...X	...M	...F	...A	...C ...E	...Z	...T	L	...O ...P ...W ...R	...V
ZUB	SB	4Y2X		F		2C	10Z			20	

Ordering table											
Size		18	25	32	40	50	63	Condi- tions	Code	Enter code	
↓	Accessories	Supplied separately								ZUB-	ZUB-
0	Slot cover	Sensor slot	1 ... 10						...S		
		Mounting slot	–	–	1 ... 10					...B	
	Slot nut	for mounting slot	1 ... 10						...Y		
		for slide	–	1 ... 10				X	
	Central support	1 ... 10								...M	
	Foot mounting (kit)	1 ... 10								...F	
	Emergency buffer and retainer	1 ... 2	1 ... 2	–	1 ... 2	–	1 ... 2	[3]	...A		
		Effective stroke reduction [mm] with emergency buffer at both ends									
		(10)	(30)	–	(60)	–	(100)				
	Shock absorber and retainer	1 ... 2							[4]	...C	
		for dust-proof version	–	1 ... 2		–	–	[5]	...E		
	Centring sleeve (pack of 10)	10, 20, 30, 40, 50, 60, 70, 80, 90								...Z	
	Sensor bracket	1 ... 5		–	1 ... 5		–	1 ... 5	...T		
	Switching lug	1		–	1		–	1	L		
	Inductive proximity sensor	NO contact, cable	1 ... 5		–	1 ... 5		–	1 ... 5	...O	
		NC contact, cable	1 ... 5		–	1 ... 5		–	1 ... 5	...P	
		NO contact, plug	1 ... 5		–	1 ... 5		–	1 ... 5	...W	
		NC contact, plug	1 ... 5		–	1 ... 5		–	1 ... 5	...R	
	Plug socket with cable, 2.5 m	1 ... 5		–	1 ... 5		–	1 ... 5	...V		

- [3] A Not with passive guide axis P.
Mounted as standard for slides GV, GA.
- [4] C Only with slides GK and GV.

- [5] E Only with slide GA

Transfer order code

ZUB –

Passive guide axes FDG, without drive

Accessories



System components
Passive guide axes

3.1

Foot mounting HP (Order code: F)



HP-25

Material:
Galvanised steel

Free of copper, PTFE and silicone

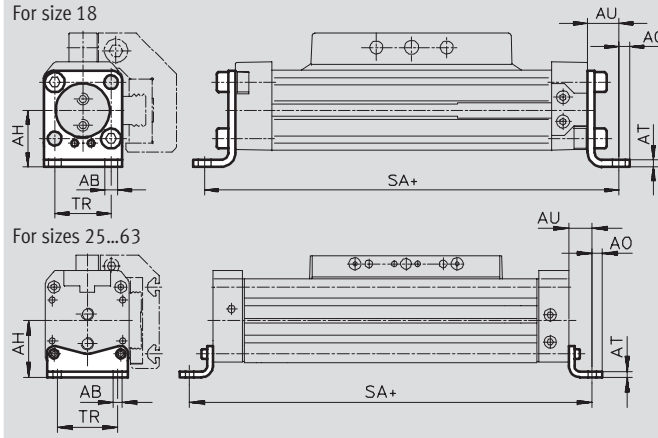

Dimensions and ordering data

For size	AB ∅	AH	AO	AT	AU	SA	TR	Weight [g]	Part No.	Type
18	5.5	24	4.8	3	13.2	176	24	70	158 472	HP-18
25	5.5	29.5	6	3	13	226	32.5	61	150 731	HP-25
32	6.6	37	7	4	17	284	38	117	150 732	HP-32
40	6.6	46	8.5	5	17.5	335	45	188	150 733	HP-40
50	9	61	11	6	25	400	65	243	150 734	HP-50
63	11	69	13.5	6	28	456	75	305	150 735	HP-63

Central support MUP (Order code: M)



MUP-40

Material:
Galvanised steel

Free of copper, PTFE and silicone

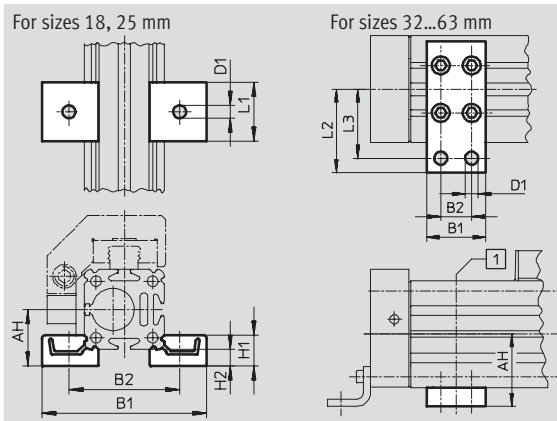

1 Position of the central support along the profile barrel is freely selectable

Dimensions and ordering data

For size	AH	B1	B2	D1 ∅	H1	H2	L1	L2	L3	Weight [g]	Part No.	Type
18	24	70.5	47	5.5	13	7	25	-	-	33	150 736	MUP-18/25
25	29.5	81	58	5.5	13	7	25	-	-	33	150 736	MUP-18/25
32	37	35	22	6.6	-	-	-	41.5	35	89	150 737	MUP-32
40	46	35	22	6.6	-	-	-	47	40	126	150 738	MUP-40
50	61	50	26	11	-	-	-	70	58	241	150 739	MUP-50
63	69	50	26	11	-	-	-	77	65	340	150 800	MUP-63

Passive guide axes FDG, without drive

Accessories

Shock absorber YSR-...-C

(Order code: C)

Material:

Housing: Galvanised steel; piston rod: high-alloy steel,

Seals: Perbunan, polyurethane
Free of copper, PTFE and silicone



 Note
Shock absorber YSRW with progressive characteristic
➔ Volume 1

Ordering data			
For size	Weight [g]	Part No.	Type
18	30	34 571	YSR-8-8-C
25	70	34 572	YSR-12-12-C
32	70	34 572	YSR-12-12-C
40	140	34 573	YSR-16-20-C
50	140	34 573	YSR-16-20-C
63	240	34 574	YSR-20-25-C

Shock absorber retainer KYP

(Order code: C)

Material:

Retainer: Aluminium
Sleeve: Steel, corrosion resistant

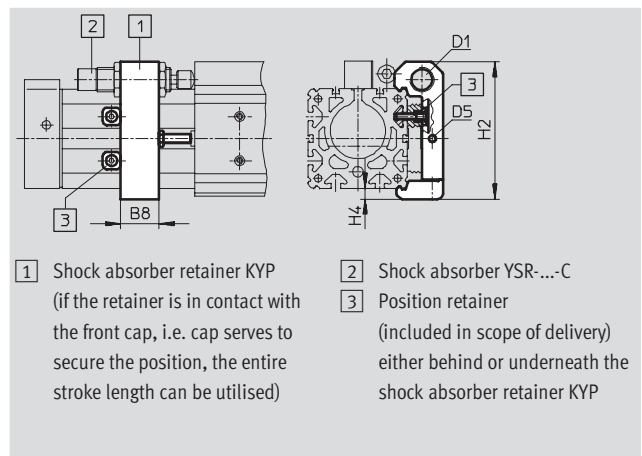

Dimensions and ordering data							
For size	B8	D1	D5	H2	H4	Weight [g]	Part No. Type
18	14	M12x1	M4	50.5	4.5	66	158 907 KYP-18
25	19	M16x1	M5	69.5	6	95	158 908 KYP-25
32	25	M16x1	M5	80	8	130	158 909 KYP-32
40	32	M22x1.5	M5	102	8	209	158 910 KYP-40
50	35	M22x1.5	M8	124	10	415	158 911 KYP-50
63	44	M26x1.5	M10	152.5	11.5	609	158 912 KYP-63

Passive guide axes FDG, without drive

Accessories



Emergency buffer NPE

(Order code: A)

Material:
Polyurethane

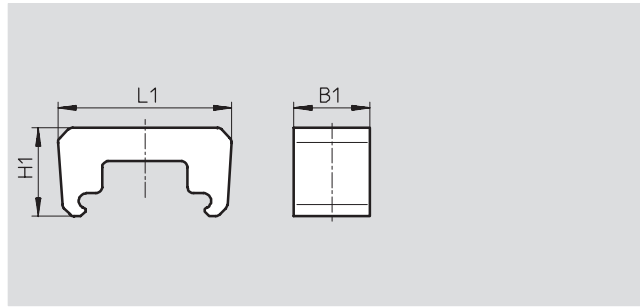

Dimensions and ordering data						
For size	B1	L1	H1	Weight [g]	Part No.	Type
18	15	43.1	28.5	6	193 901	NPE-18
25	25	57	29	12	193 902	NPE-25
40	40	80.5	36	41	193 904	NPE-40
63	60	128.6	55	152	193 906	NPE-63

-  - Note
The emergency buffer can only be used in conjunction with shock absorber retainer KYP. → 5 / 3.1-59 (A threaded pin and nut are not required.)

Shock absorber DG-GA

for protected version GA
(Order code: E)

Material:
Housing: Galvanised steel; piston rod: high-alloy steel
Seals: Perbunan, polyurethane
Free of copper, PTFE and silicone



Ordering data			
For size	Weight [g]	Part No.	Type
25	70	192 875	DG-GA-25-YSR
40	140	192 877	DG-GA-40-YSR

Passive guide axes FDG, without drive

Accessories

Sensor bracket HWS

For inductive proximity sensors

(Order code: T)

Material:

Galvanised steel



Switching lug SF

(Order code: L)

Material:

Galvanised steel

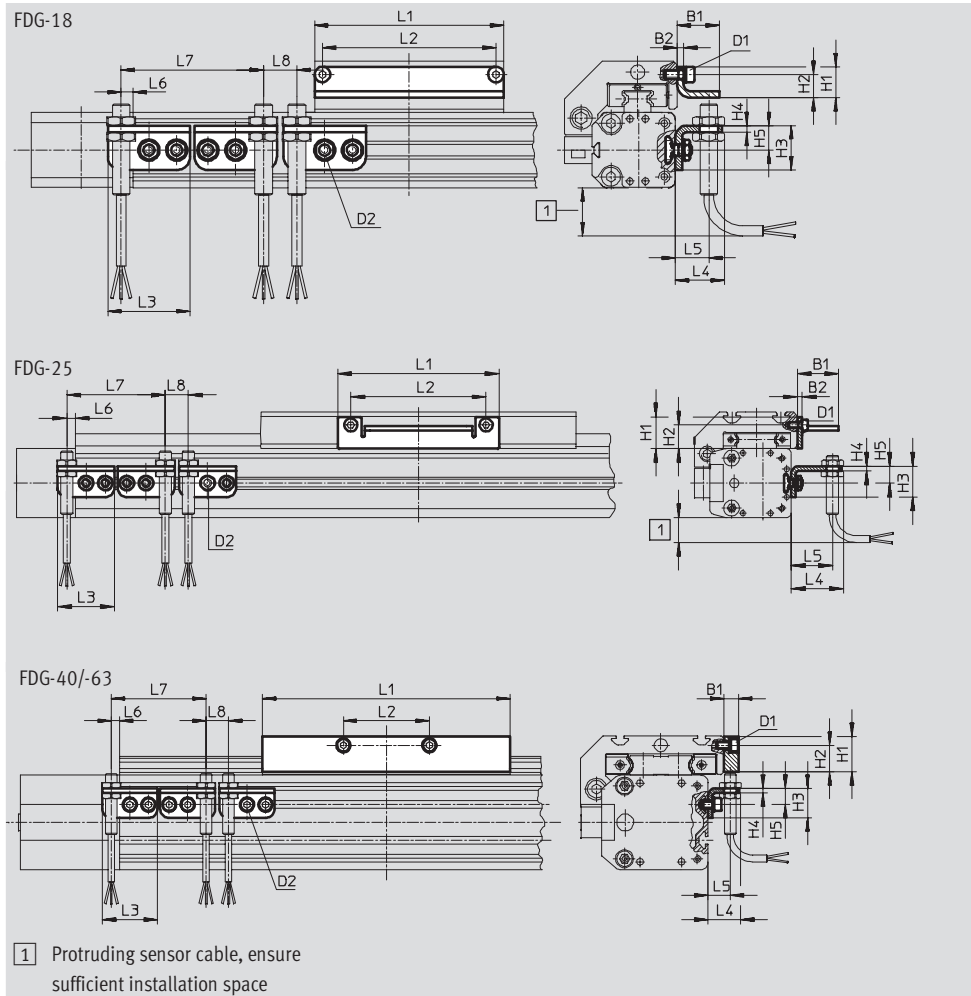

Dimensions and ordering data											
For size	D1	D2	B1	B2	H1	H2	H3	H4	H5	L1	L2
18	M4	M5	19	3	14	10.5	20	3	11	85	78
25	M5	M5	27	3	20.5	15.3	20	3	11	105	88
40	M5	M5	10	-	24	18	20	3	11	167	58
63	M8	M5	10	-	35	25	20	3	11	230	72

For size	L3	L4	L5	L6 max.	L7 min.	L8 min.	Weight [g]	Part No.	Type
18	37	22.5	15	5.5	64	15	30	188 968	HWS-18/25-M8
							60	188 964	SF-18
25	37	34.5	27	5.5	64	15	30	540 780	HWS-25-MAB-M8
							80	540 430	SF-25-MAB
40	37	22.5	15	5.5	64	15	40	188 969	HWS-40-M8
							310	188 966	SF-40
63	37	22.5	15	5.5	64	15	40	188 970	HWS-63-M8
							630	188 967	SF-63



Passive guide axes FDG, without drive

Accessories

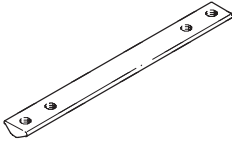

System components
Passive guide axes

3.1

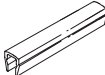
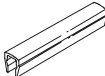



Ordering data				Technical data → Volume 1		
	For size	Remarks	Order code	Part No.	Type	PU ¹⁾
Slot nut NST						
	18, 25	For mounting slot	Y	526 091	NST-HMV-M4	1
	32, 40			150 914	NST-5-M5	1
	50, 63			150 915	NST-8-M6	1
Slot nut NSTL						
	25	For slide	X	158 410	NSTL-25	1
	32			158 411	NSTL-32	1
	40			158 412	NSTL-40	1
	50			158 413	NSTL-50	1
	63			158 414	NSTL-63	1
Centring pin/sleeve ZBS/ZBH						
	18	For slide	Z	150 928	ZBS-5	10
	25 ... 63			150 927	ZBH-9	10
Slot cover ABP						
	32, 40	For mounting slot 0.5 m each	B	151 681	ABP-5	2
	50, 63			151 682	ABP-8	
Slot cover ABP-S						
	18 ... 63	For sensor slot 0.5 m each	S	151 680	ABP-5-S	2



1) Packaging unit quantity

Passive guide axes FDG, without drive

Accessories



Ordering data – Inductive proximity sensors M8						Technical data → Volume 4	
	Electrical connection		Switch output	LED	Cable length [m]	Part No.	Type
	Cables	M8 plug					
NO contact							
	3-wire	–	PNP	■	2.5	150 386	SIEN-M8B-PS-K-L
	–	3-pin	PNP	■		150 387	SIEN-M8B-PS-S-L
NC contact							
	3-wire	–	PNP	■	2.5	150 390	SIEN-M8B-PO-K-L
	–	3-pin	PNP	■		150 391	SIEN-M8B-PO-S-L

Ordering data – Plug sockets with cable						Technical data → Volume 1	
	Mounting	Switch output		Connection	Cable length [m]	Part No.	Type
		PNP	NPN				
Straight socket							
	M8 union nut	■	■	3-pin	2.5	159 420	SIM-M8-3GD-2,5-PU
					5	159 421	SIM-M8-3GD-5-PU
Angled plug socket							
	M8 union nut	■	■	3-pin	2.5	159 422	SIM-M8-3WD-2,5-PU
					5	159 423	SIM-M8-3WD-5-PU

Heavy-duty guides HD, without drive

Peripherals overview

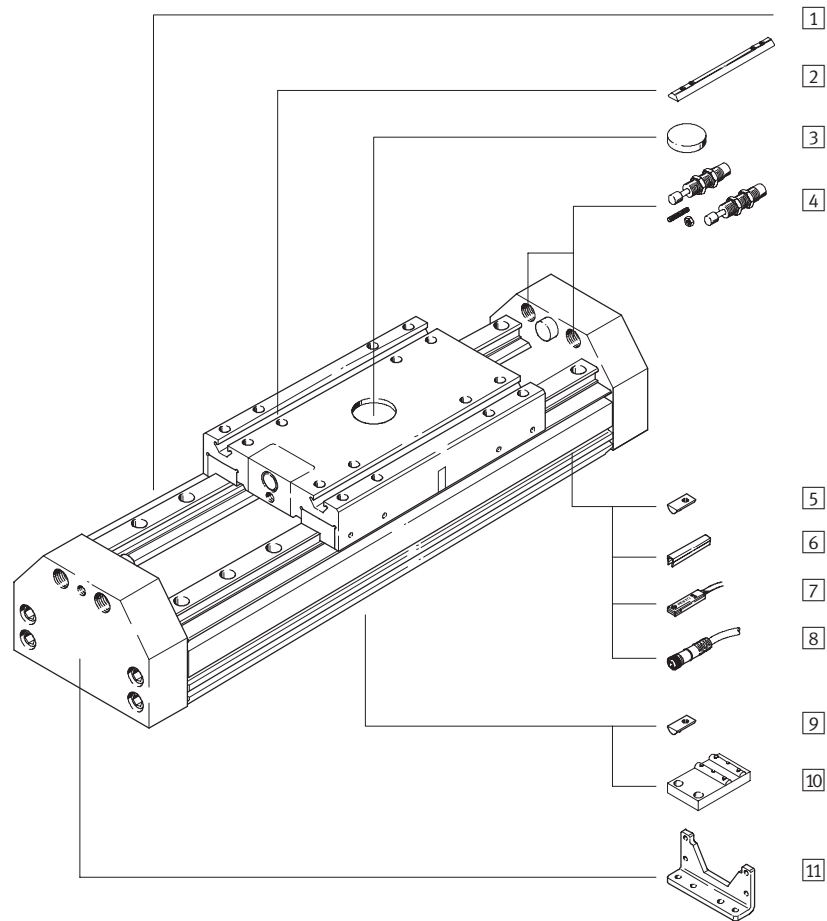

Variants and accessories		
Type	Brief description	→ Page
1 Heavy-duty guide HD	Guide without drive	5 / 3.1-65
2 Slot nut for slide X	For mounting loads and attachments on the slide	5 / 3.1-73
3 Central mounting Q	For centring loads and attachments on the slide	5 / 3.1-73
4 Shock absorber kit D	Absorbs the energy created by the movement of the slide when it reaches the end position	5 / 3.1-73
5 Slot nut for profile barrel at side Y	For mounting attachments	5 / 3.1-73
6 Slot cover B/S	To protect against the ingress of dirt	5 / 3.1-73
7 Proximity sensors G/H/I/J/N	For providing a proximity signal or safety check	5 / 3.1-74
8 Plug socket with cable V	For proximity sensor	5 / 3.1-74
9 Slot nut for profile barrel underneath U	For mounting attachments	5 / 3.1-73
10 Central support M	To mount the axis	5 / 3.1-72
11 Foot mounting F	To mount the axis	5 / 3.1-72

Heavy-duty guides HD, without drive

Type codes

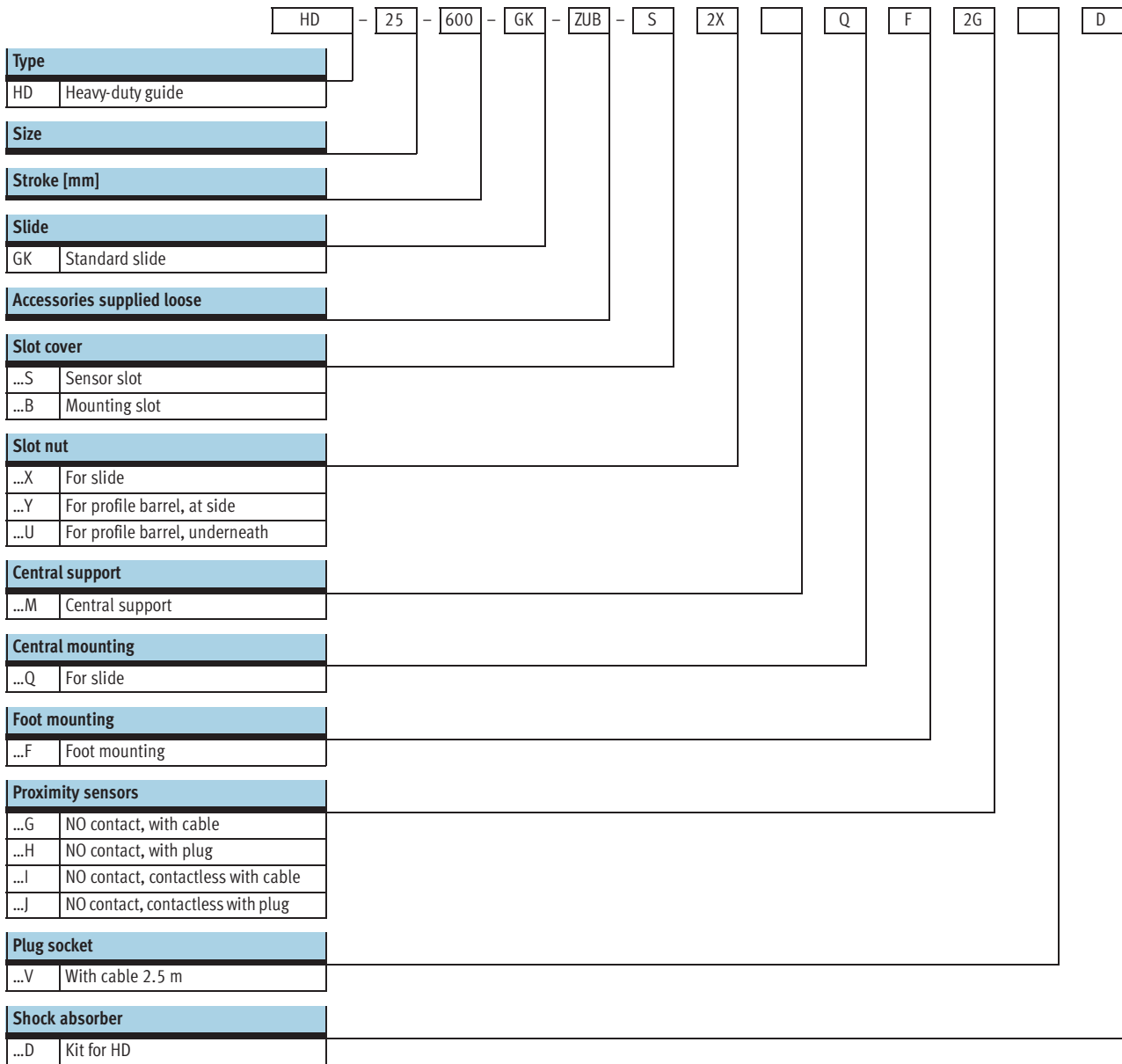

Heavy-duty guides HD, without drive

Technical data



- - Size
8 ... 40
- - Stroke length
10 ... 2,110 mm

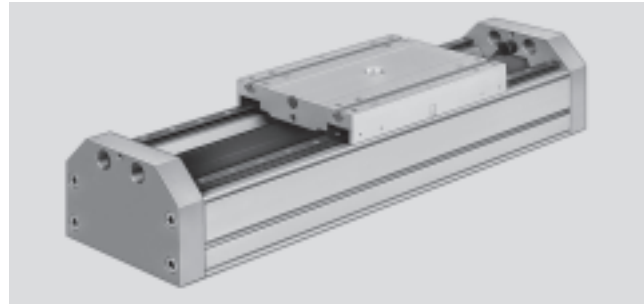

General technical data						
Size		HD8	HD12	HD18	HD25	HD40
Max. stroke	[mm]	10 ... 1,080	10 ... 1,550	10 ... 1,810	10 ... 2,160	10 ... 2,110
Guide		External recirculating ball bearing guide				
Fitting position		Any				
Cushioning		Not adjustable at either end				
		Self-adjusting at both ends				
Type of mounting		Profile mounting				
		Foot mounting				
Max. speed	[m/s]	3				
Ambient temperature	[°C]	-10 ... +60				

Weights [kg]						
Size		HD8	HD12	HD18	HD25	HD40
Basic weight at 0 mm stroke		0.86	1.37	2.95	3.6	11.8
Additional weight per 100 mm stroke		0.33	0.46	0.72	1.16	1.76
Moving load		0.195	0.33	0.45	1.78	3.3

Materials

Sectional view

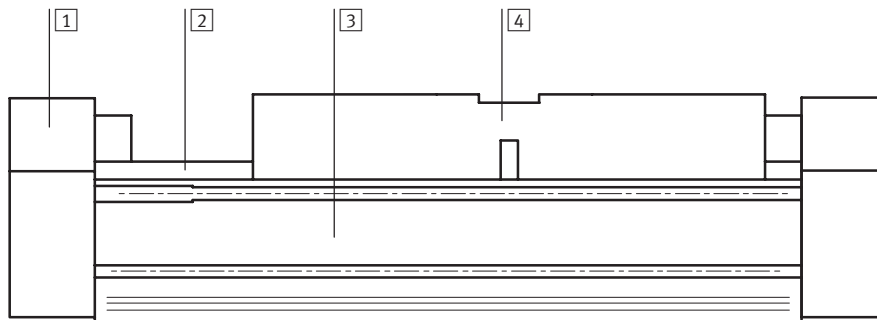

Axis	
1	End cap Anodised aluminium
2	Guide Rolled steel
3	Profile Anodised aluminium
4	Slide Anodised aluminium

Heavy-duty guides HD, without drive

Technical data

Characteristic load values

The forces and torques specified refer to the centre of the guide rails.

They must not be exceeded during dynamic operation.

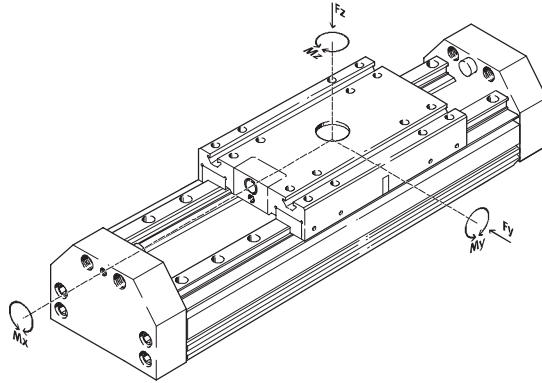

If the heavy-duty guide is simultaneously subjected to several of the forces and torques listed below, the following equations must be satisfied in addition to the indicated maximum loads.

$$\frac{F_y}{F_{y_{max}}} + \frac{F_z}{F_{z_{max}}} + \frac{M_x}{M_{x_{max}}} + \frac{M_y}{M_{y_{max}}} + \frac{M_z}{M_{z_{max}}} \leq 1$$

Permissible forces and torques						
Size		HD8	HD12	HD18	HD25	HD40
F _{y_{max.}}	[N]	518	1 120	1 820	5 400	5 400
F _{z_{max.}}	[N]	518	1 120	1 820	5 600	5 600
M _{x_{max.}}	[Nm]	12.6	33.6	70	260	375
M _{y_{max.}}	[Nm]	16.8	50.4	115	415	560
M _{z_{max.}}	[Nm]	16.8	49	112	400	540

Heavy-duty guides HD, without drive

Technical data



Maximum permissible support span l as a function of the force F

The drive may need to be supported with central supports MUP in order to limit deflection in the case of large strokes. The following diagrams serve

to determine the maximum permissible support span l as a function of the force F .

Load on the surface of the slide

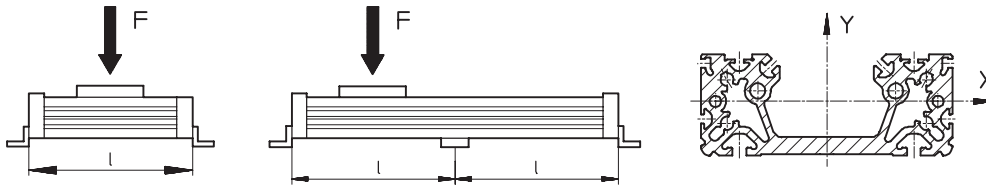

Maximum permissible support span l (without central support) as a function of the force F

Deflection around the X axis

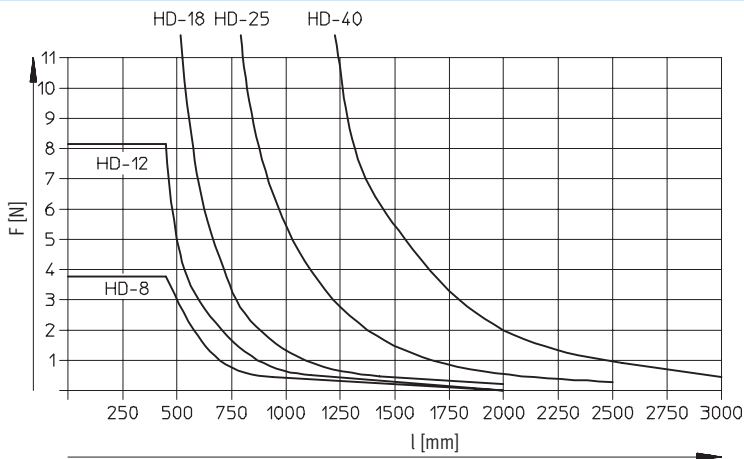

Deflection around the Y axis

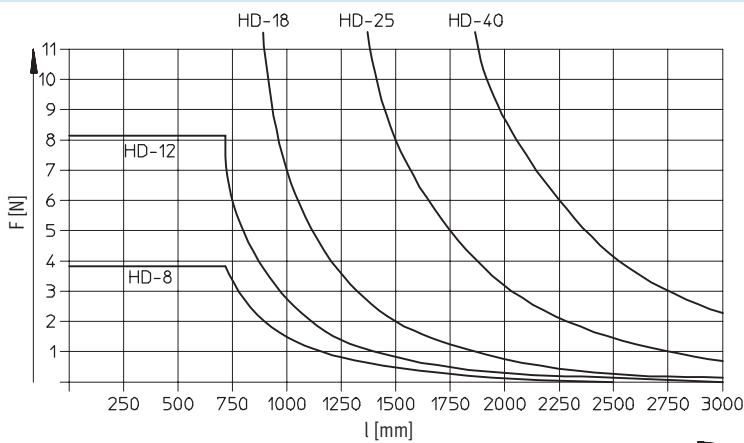

Heavy-duty guides HD, without drive

Technical data



Dimensions

Download CAD data → www.festo.com/en/engineering

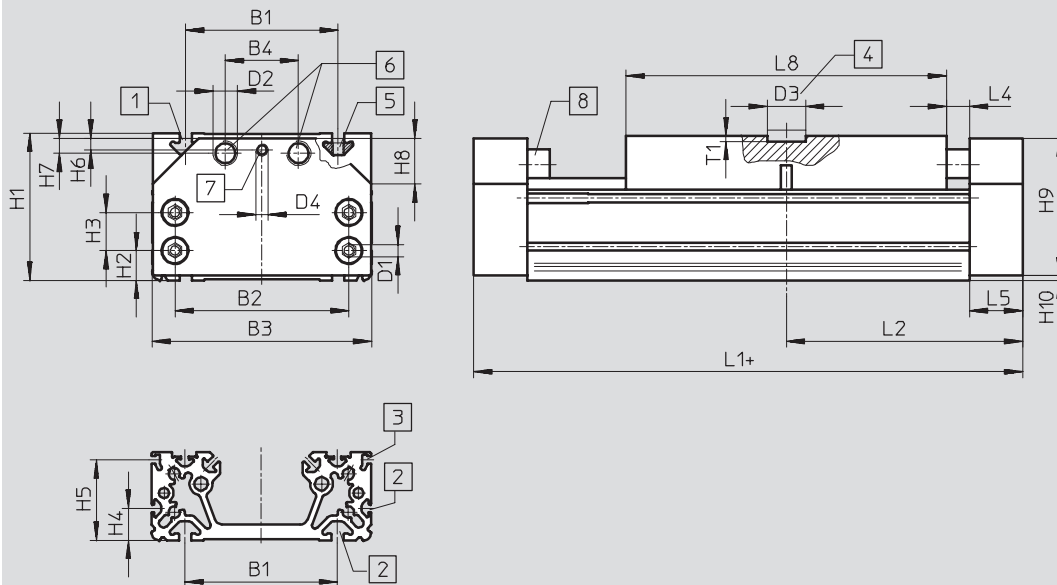

- 1 Mounting slot for slot nut NSTH
 - 2 Mounting slot for slot nut NST
 - 3 Sensor slot for proximity sensor SME/SMT-8
 - 4 Central mounting SLZZ
 - 5 Slot nut NSTH
 - 6 Thread for shock absorber YHD or YSR...-C
 - 7 Thread for threaded pin (shock absorber kit)
 - 8 Rubber buffer
- + = plus stroke length

Size	B1	B2	B3	B4	D1	D2	D3 Ø G7	D4	H1	H2	H3	H4
8	50 ±0.2	46 ±0.1	75	26	M5	M10x1	25	M3	48.2	9.5	14 ±0.1	8.5
12	60 ±0.3	65 ±0.1	89	30		M12x1		M4	59.5	11	19 ±0.1	12
18	80 ±0.3	85 ±0.2	116	40		M8		M8	69.9	12.8	19.5 ±0.1	14
25	100 ±0.3	114 ±0.2	144	48	M8	M16x1		M8	93.5	18.5	25 ±0.2	21
40	140 ±0.35	156 ±0.2	185	54		M22x1.5			124.5	21	48 ±0.2	35

Size	H5	H6	H7	H8	H9	H10	L1	L2	L4	L5	L8	T1
8	29.3	2.4	8	15x45°	47	0.5	160	80	15	20	90	-
12	35.3	4	6.5	18x45°	58		190	95		120	3.5	
18	42.3	5.9	8.7	20x45°	68	0.8	240	120		160		
25	52.8	9	9.75	30x45°	90	2.0	310	155		210		
40	82.8	5.5	15.5	35x45°	120		354	177		260		4

Heavy-duty guides HD, without drive

Ordering data – Modular product system



M Mandatory data →

Module No.	Guide	Size	Stroke	Basic variant
170 023	HD	8	10 ... 2,160	GK
170 024		12		
170 025		18		
170 026		25		
170 027		40		
Ordering example				
170 026	HD	25	500	GK

Ordering table

Size	8	12	18	25	40	Condi- tions	Code	Enter code
M Module No.	170 023	170 024	170 025	170 026	170 027			
Guide	Heavy-duty guide						HD	HD
Size	8	12	18	25	40		-...	
Stroke [mm]	10 ... 1,080	10 ... 1,550	10 ... 1,810	10 ... 2,160	10 ... 2,110		-...	
↓ Basic variant	Standard slide						-GK	-GK

Transfer order code

	HD	-		-		-	GK
--	-----------	---	--	---	--	---	-----------

Heavy-duty guide HD, without drive

Ordering data – Modular product system



Options

Accessories	Slot cover	Slot nut	Central support	Central mounting	Foot mounting	Proximity sensors	Plug socket	Shock absorber kit
ZUB	...S ...B	...X ...Y ...U	...M	...Q	...F	...G ...H ...I ...J	...V	...D
ZUB	- 2S2B	2X		Q	F			2D

Ordering table

Size	8	12	18	25	40	Condi- tions	Code	Enter code	
0 Accessories	Supplied separately							ZUB-	ZUB-
Slot cover (x2, 0.5 m)	Sensor slot	1 ... 10					...S		
	Mounting slot underneath	-	1 ... 10					...B	
Slot nut for	slide	1 ... 10					...X		
	profile barrel, side	-	-	1 ... 10			...Y		
	profile barrel, bottom	-	1 ... 10					...U	
Central support	1 ... 10					...M			
Central mounting for	slide	-	1 ... 10					...Q	
Foot mounting (kit)	1 ... 10					...F			
Magnetic proximity sensor	with cable 2.5 m	1 ... 10 (SME-8-K-LED-24)					...G		
	with plug	1 ... 10 (SME-8-S-LED-24)					...H		
	Contactless, with cable 2.5 m	1 ... 10 (SMT-8-PS-K-LED-24)					...I		
	Contactless, with plug	1 ... 10 (SMT-8-PS-S-LED-24)					...J		
Plug socket	with cable 2.5 m	1 ... 10 (SIM-M8-3GD-2,5-PU)					...V		
Shock absorber kit	1 ... 10					...D			

Transfer order code

ZUB - [] [] [] [] [] [] [] [] []

Heavy-duty guides HD, without drive

Accessories



Foot mounting HHP

(Order code: F)

Material:
Galvanised steel
Free of copper, PTFE and silicone



Central support MUP

(Order code: M)

Material:
Galvanised steel
Free of copper, PTFE and silicone

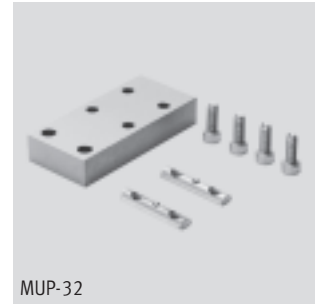

MUP-32

System components
Passive guide axes

3.1

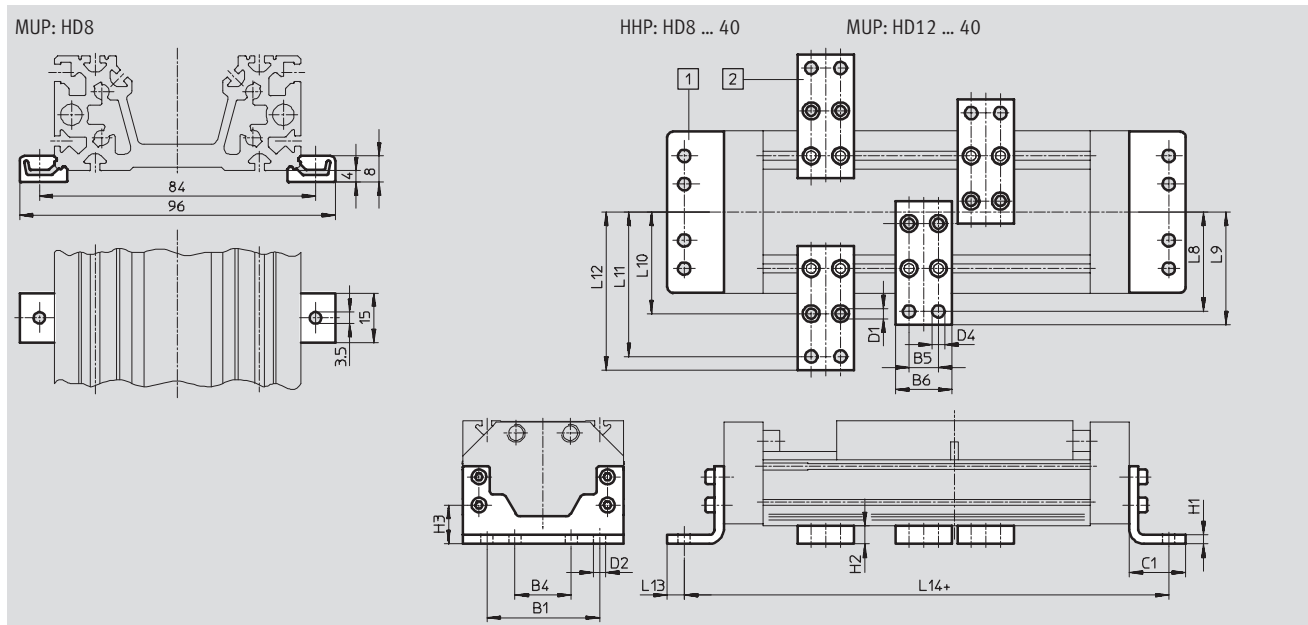

Dimensions and ordering data											
For size	B1	B4	B5	B6	C1	D1 Ø	D2 Ø	D4 Ø	H1	H2	H3
8	50	25	-	-	23	-	5.5	-	5	-	13.5
12	60	30	22	35	28	5.5	6.6	6.6	6	10	21
18	80	40	22	35	34	5.5	6.6	6.6	8	14	26.8
25	100	50	26	50	50	9	11	11	8	16	34.5
40	140	70	26	50	50	9	11	11	10	16	37

For size	L8	L9	L10	L11	L12	L13	L14	Weight [g]	Part No.	Type
8	-	-	-	-	-	6	194	105	161 991	HHP-8
								8	160 909	MUP-8/12
12	54	60.5	52	76	82.5	8	230	186	161 992	HHP-12
								89	150 737	MUP-32
18	68	75	64	92	99	9	290	357	161 993	HHP-18
								126	150 738	MUP-40
25	88	100	90	128	140	15	380	794	161 994	HHP-25
								347	150 739	MUP-50
40	108	120	110	148	160	15	424	1,318	161 995	HHP-40
								347	150 739	MUP-50

Heavy-duty guides HD, without drive

Accessories



Shock absorber kit YHD

(Order code: D)

Material:





Galvanised steel housing

TPE-U(PU) NBR seals

Free of copper, PTFE and silicone

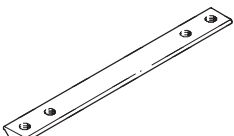

Ordering data			
For size	Weight [g]	Part No.	Type
8	168	174 542	YHD-8
12	170	174 543	YHD-12
18	203	174 544	YHD-18
25	293	174 545	YHD-25
40	515	174 546	YHD-40

Ordering data				Technical data → Volume 1		
	For size	Remarks	Order code	Part No.	Type	PU ¹⁾
Slot nut NST						
	18	For profile barrel, at side	Y	150 914	NST-5-M5	1
	25			150 914	NST-5-M5	1
	40			150 915	NST-8-M6	1
	12	For profile barrel, underneath	U	150 914	NST-5-M5	1
	18			150 914	NST-5-M5	1
	25			150 915	NST-8-M6	1
	40			150 915	NST-8-M6	1
	Slot nut NSTH					
	8	For slide	X	161 018	NSTH-8	1
	12			161 019	NSTH-12	1
	18			161 020	NSTH-18	1
	25			161 021	NSTH-25	1
	40			161 022	NSTH-40	1
	Central mounting SLZZ					
	12 ... 40	For slide	Q	150 901	SLZZ-25/16	1
Slot cover ABP						
	12	For mounting slot, side and underneath	B	151 681	ABP-5	2
	18			151 681	ABP-5	
	25 underneath	0.5 m each		151 681	ABP-5	
	25 lateral			151 682	ABP-8	
	40			151 682	ABP-8	
Slot cover ABP-S						
	8 ... 40	For sensor slot 0.5 m each	S	151 680	ABP-5-S	2

1) Packaging unit quantity

Heavy-duty guides HD, without drive

Accessories



Ordering data – Proximity sensor for T-slot, magnetic reed					Technical data → Volume 1	
	Mounting	Electrical connection		Cable length [m]	Part No.	Type
		Cables	M8 plug			
NO contact						
	Insertable, flush with the cylinder profile	3-wire	–	2.5	150 855	SME-8-K-LED-24
		–	3-pin	0.3	150 857	SME-8-S-LED-24
NC contact						
	Insertable from end, flush with the cylinder profile	3-wire	–	7.5	160 251	SME-8-O-K-LED-24

Ordering data – Proximity sensor for T-slot, magneto-resistive					Technical data → Volume 1		
	Mounting	Switch output	Electrical connection		Cable length [m]	Part No.	Type
			Cables	M8 plug			
NO contact							
	Insertable, flush with the cylinder profile	PNP	3-pin	–	2.5	175 436	SMT-8-PS-K-LED-24-B
			–	3-pin	0.3	175 484	SMT-8-PS-S-LED-24-B
NC contact							
	Insertable from above	PNP	3-wire	–	7.5	525 911	SMT-8F-PO-24V-K7,5-OE

Ordering data – Plug sockets with cable					Technical data → Volume 1		
	Mounting	Switch output		Connection	Cable length [m]	Part No.	Type
		PNP	NPN				
Straight socket							
	M8 union nut	■	■	3-pin	2.5	159 420	SIM-M8-3GD-2,5-PU
					5	159 421	SIM-M8-3GD-5-PU
Angled plug socket							
	M8 union nut	■	■	3-pin	2.5	159 422	SIM-M8-3WD-2,5-PU
					5	159 423	SIM-M8-3WD-5-PU