

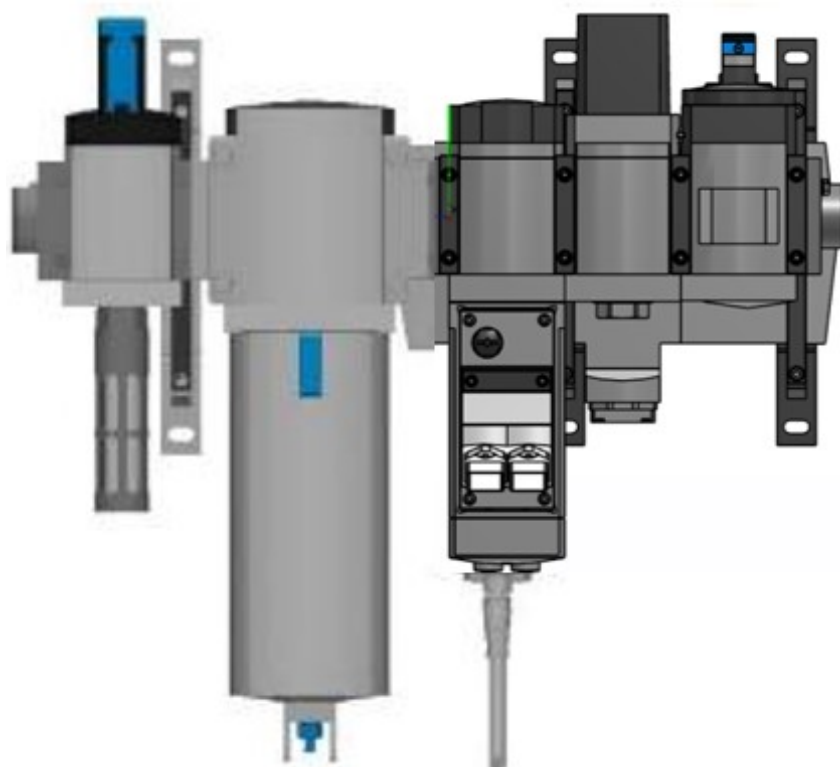

Brief description of
Maintenance Unit 3/4" HIGHFLOW
with C2M Part No.: 8186121



Creation date 12 /2025
Creator Festo: Dietmar Düll, Hilmar Klee
Version 1.1

All technical information
is correct at the time of going to press.

All
texts, illustrations, figures
and drawings contained in this publication are
the property of Festo SE & Co. KG and are therefore
protected by copyright.
Any reproduction
, editing, translation
, microfilming
, storage and processing
in electronic systems is
not permitted
without the
consent of Festo SE & Co KG

.
The trademarks,
logos or service marks used
are
trademarks of their respective owners in
certain countries.

Constant technical
progress means that changes are inevitable.

Festo AG & Co KG

Ruiter Street 82
73734 Esslingen

Index

Change Index	4
1 Maintenance unit 3/4" Highflow with C2M	5
2 Energy efficiency module "C2M"	6
2.1 Data Sheet.....	7
2.2 Important Notes	9
3 Flow rate	10
3.1 Table Maintenance unit 3/4" HIGHFLOW C2M	10
3.2 Flow characteristic curve maintenance unit 3/4" HIGHFLOW	11
3.3 Flow rate calculation tool	12
3.4 Tubing flow rate table.....	13
4 Status LEDs of the energy efficiency module „C2M“	14
5 Interfaces and display components on the bus node FB 44	15
6 BMW SAS Module	16

1 Maintenance unit 3/4" Highflow with C2M

Type / Name: **Maintenance unit 3/4" HIGHFLOW C2M**
 Part No.: 8186121
 BMW-FM-Nr: 3C28064
 Connection: 3/4"

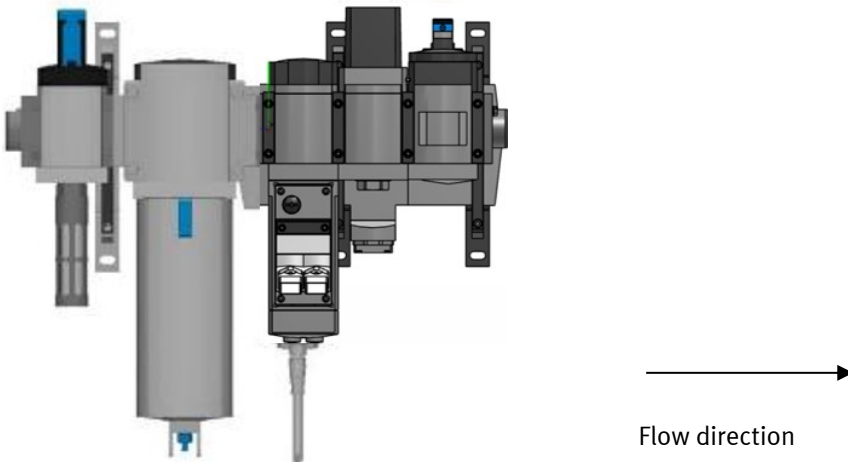

Spare part: filter cartridge 40µm 570310 MS9-LFP-E

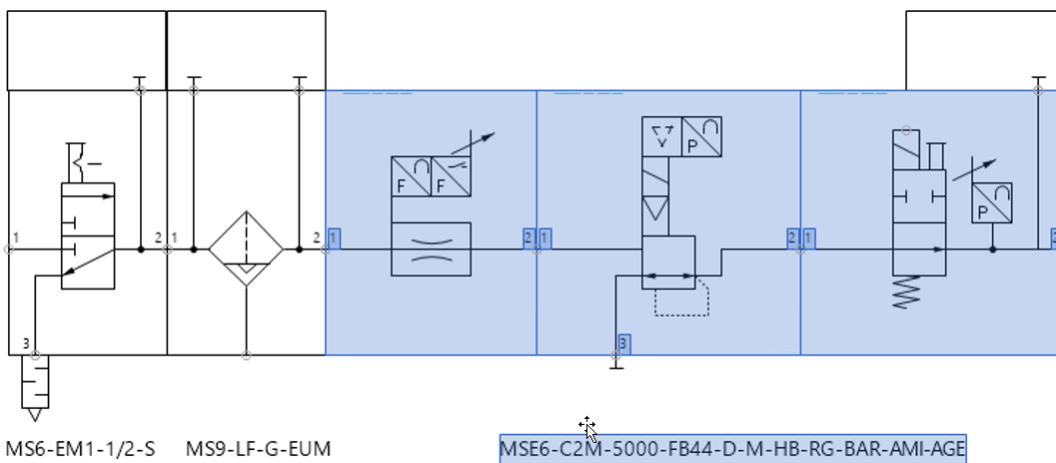

2 Energy efficiency module "C2M"

8227267 MSE6-C2M-5000-FB44-D-M-RG-BAR-AMI-AGE

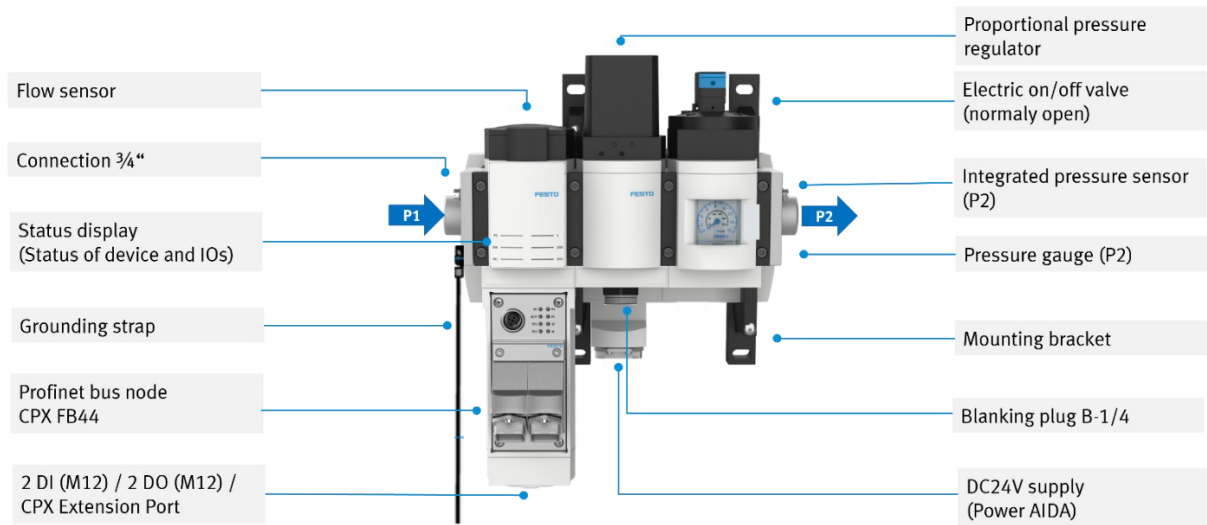

2.1 Data Sheet

8227267 MSE6-C2M-5000-FB44-D-M-RG-BAR-AMI-AGE

Feature	Value
Size	6
Series	MSE
Mounting position	Horizontal +/-5°
Valve function	2/2 open, monostable
Type of reset	Mechanical spring
Operating pressure	0.5 MPa ... 1.1 MPa
Operating pressure	5 bar ... 11 bar
Operating pressure	72.5 psi ... 159.5 psi
Pressure regulation range	0.25 MPa ... 1 MPa
Pressure regulation range	2.5 bar ... 10 bar
Pressure regulation range	36.25 psi ... 145 psi
Max. pressure hysteresis	0.03 MPa
Max. pressure hysteresis	0.3 bar
Max. pressure hysteresis	4.35 psi
Standard nominal flow rate (standardised to DIN 1343)	7000 l/min See chapter 3!
Duty cycle	100%
Max. current consumption, load	≤0.26 A
Max. current consumption, logic	≤0.32 A
Max. resultant current	1 A
Approval	RCM trademark
KC mark	KC-EMV
CE mark (see declaration of conformity)	To EU EMC Directive In accordance with EU RoHS Directive
UKCA marking (see declaration of conformity)	To UK instructions for EMC To UK RoHS instructions
Operating medium	Compressed air to ISO 8573-1:2010 [7:4:4]
Note on operating and pilot medium	Lubricated operation not possible
LABS (PWIS) conformity	VDMA24364-B1/B2-L
Storage temperature	-10 °C ... 60 °C
Media temperature	0 °C ... 50 °C
Degree of protection	IP65 With plug socket
Ambient temperature	0 °C ... 50 °C
Product weight	4550 g
Electrical connection	5-pin AIDA push-pull
Pneumatic connection, port 1	G3/4
Pneumatic connection, port 2	G3/4
Material seals	NBR
Material housing	Die-cast aluminium
Material covering	PA-reinforced
Material cover	PA-reinforced

Feature	Value
Field bus interface	2x RJ45 push-pull socket, AIDA
Operating voltage range DC electronics/sensors	18 V ... 30 V
Operating voltage DC load voltage	21.6 V ... 28.8 V
Reverse polarity protection	For operating voltage connections
Displayable units	kPa;l/min;m3;mbar;psi;scf;scfm
Start value for flow rate measuring range	50 l/min
End value for flow rate measuring range	5000 l/min
Accuracy of flow rate	± (3% o.m.v. + 0.3% FS)
Start value for pressure measuring range	0 MPa
Start value for pressure measuring range	0 bar
Start value for pressure measuring range	0 psi
End value for pressure measuring range	1.4 MPa
End value for pressure measuring range	14 bar
End value for pressure measuring range	203 psi
Accuracy in ± % FS	3 %FS
Number of inputs	2
Switching logic for inputs	PNP (positive switching)
Number of outputs	2
Switching logic for outputs	PNP (positive switching)
Max. power supply per channel	1 A (12 W lamp load)

2.2 Important Notes

- After switching off the pressure at the inlet, there could be still a residual pressure < 1 bar ($< 0,1$ MPa) at the outlet due to function.
- The system pressure P2 above the set pressure will not be actively reduced to the set pressure. Instead, it would stay in the system until being consumed.
In this process (over pressured), it is likely to hear the switching sound of the proportional pressure regulator lasting until 1 min, which is quite normal.
This occurrence is the normal function of the regulator achieving its switching cycle.
- Energy Saving Modus: the set pressure can not be lower than 3 bar under energy saving modus. Reason: the Soft-Start valve could not hold the compressed air when the pressure is under 3 bar. The system would be exhausted.
- If the energy efficiency module MSE6-C2M-5000-FB44-D-M-RG-BAR-AMI-AGE need to be exchanged as one part, the blanking plug (**B-1/4 Tnr.: 3569**) must be installed separately.
- In case of undersupply (pressure/flow) on the side of P1, there will be no mechanical malfunction of C2M
- Further Information check Operating Instruction Energy Efficiency Module MSE6-C2M

Links:

- Documentation: [C2M_documentation.pdf](#)
- Operating instruction: [MSE6-C2M_operating-instr_2024-12d_8227992g1.pdf](#)

3 Flow rate

3.1 Table Maintenance unit 3/4" HIGHFLOW C2M

Maintenance unit 3/4" HIGHFLOW C2M Part No. 8186121				
	Normliter	min	max	Operational mains pressure
Input pressure P1	10.0 bar	5.5 bar	7.0 bar	6.5 bar
Set pressure P2	6.0 bar	5.0bar	6.5 bar	6.0 bar
Measure	6.0 bar --> 5.0 bar	5.0 bar --> 4.0 bar	6.5 bar --> 5.5 bar	6.0 bar--> 5.0 bar
Nominal flow Qn [l/min]	4500 l/min	1900 l/min	2100l/min	2000l/min

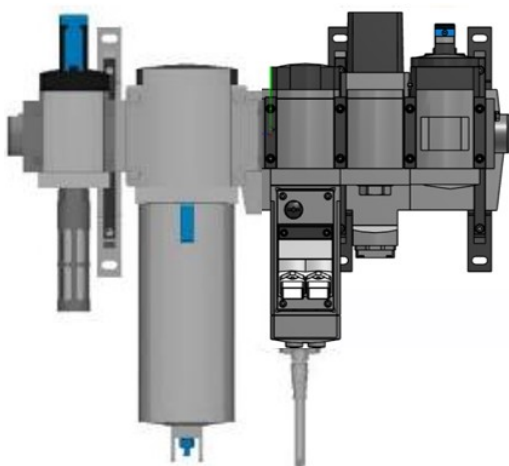

Pressure – Flow rate (The specifications could not replace the technical design from the OEM)

Flow rate (Qn) measured with 1bar pressure difference.

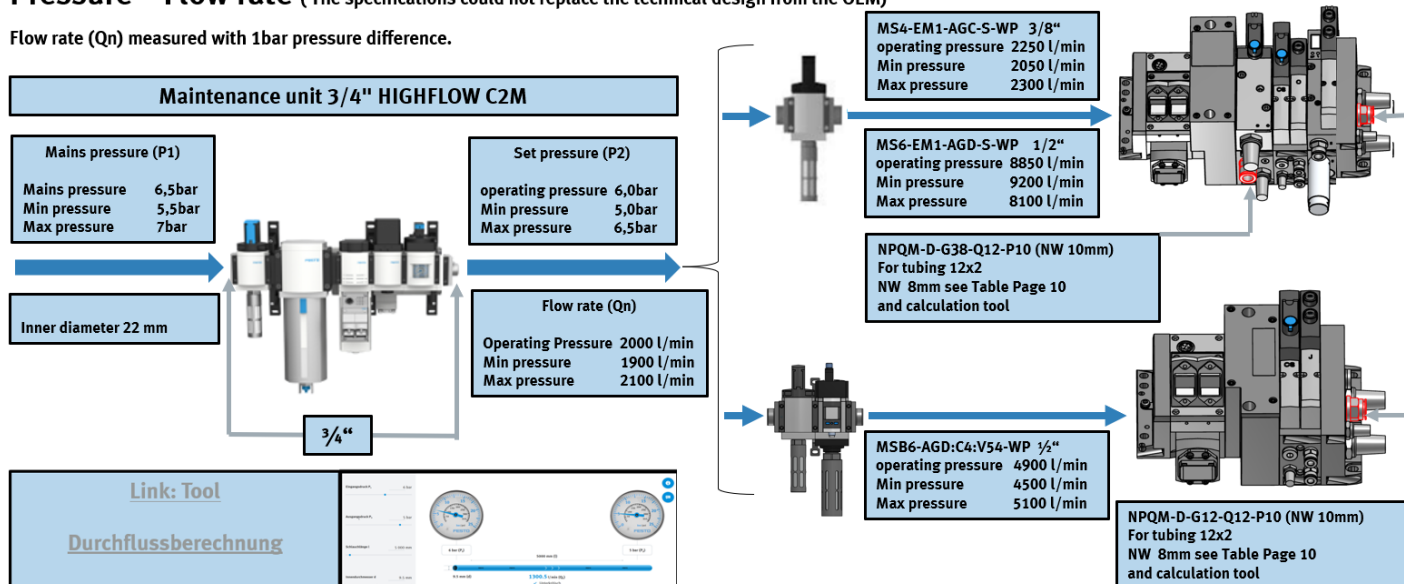

3.2 Flow characteristic curve maintenance unit 3/4" HIGHFLOW

Type / Name: **Maintenance unit 3/4" HIGHFLOW C2M**
 Part No.: 8186121
 BMW-FM-Nr: 3C28064
 Connection: 3/4"

Flow characteristic curve maintenance unit 3/4" Highflow C2M

The drop of outlet pressure P2 (Y-axis) with the rise of flow rate (X-axis).

- Mains pressure **P1 = 6,5bar**
- Target pressure **6bar**
- measurement at a minimum* pressure difference [P1 (6,5bar) – Target pressure (6bar)]

* The pressure difference (Mains pressure - Target pressure) has to be min. 0,5bar.

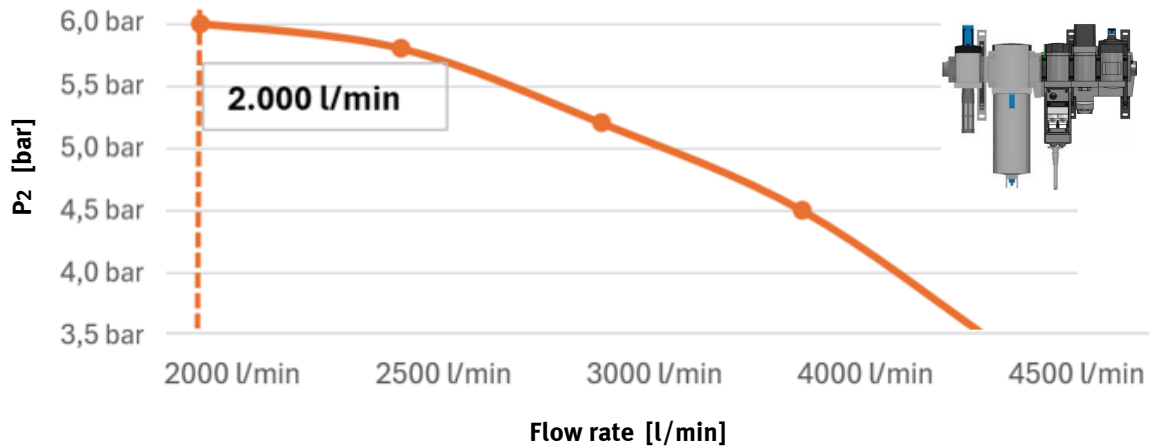

3.3 Flow rate calculation tool

Engineering Tools

Automation | Didactic | Corporate

Products | **Engineering tools** | Solutions | Support | Technical education | About Festo | Careers | 100 years

Login | Cart | United Kingd... | **FESTO**

Search by product name, reference, or category

Optimize pneumatic systems with key calculations

- Flow rate calculation**
Boost efficiency with flow rate calculation.
- Media resistance**
Check chemical resistance of tubing and materials.
- Cylinder air consumption calculation**
Improve efficiency with air consumption data.

Identify parts and connection setups instantly

- Spare parts catalogue**
Find and order exact Festo spare parts.
- QuickSearchPlus**
Access Festo product info fast and easy.
- Connectivity Finder**
Connect your PLC to Festo products easily.

Plan, document and integrate with confidence

- Festo Design Tool 3D**
Create CAD models and find accessories.
- FluidDraw**
Speed up circuit design with FluidDraw.
- EPLAN Schematic Solution**
Generate EPLAN projects with Schematic Solution.

Festo PARTdataManager
Access 2D/3D data for 33,000+ products.

Application Parameters

Calculate result for..

- Supply pressure P_1
- Output pressure P_2
- Nominal flow rate Q_n**

Supply pressure P_1 6 bar

Output pressure P_2 4 bar

Tubing length l 2 000 mm

Internal diameter d 4 mm

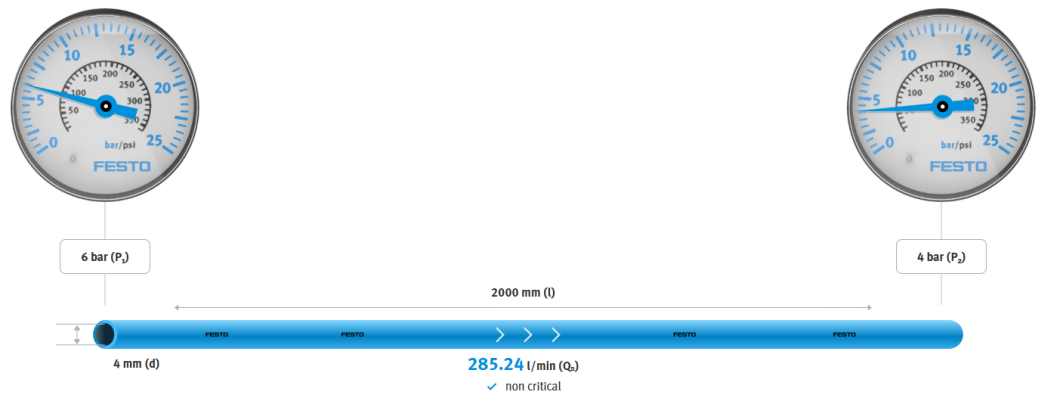

Click on the picture

Link: [Flow rate calculation | Festo GB](#)

3.4 Tubing flow rate table

Note: These are rounded theoretical values for straight tubing hoses. Please note that the flow rate may be reduced depending on the bend radius and the use of elbows, T-pieces, Y-pieces, etc.

PUN-H-6x1-SW				
Inner diameter: 4mm				
Input pressure P1	length	5,0 bar	6,0 bar	6,5 bar
Output pressure P2		4,0 bar	5,0 bar	5,5 bar
Nominal flow Qn [l/min]	1m	260 l/min	290 l/min	300 l/min
Nominal flow Qn [l/min]	2m	200 l/min	210 l/min	220 l/min
Nominal flow Qn [l/min]	3m	160 l/min	180 l/min	180 l/min
Nominal flow Qn [l/min]	4m	140 l/min	150 l/min	160 l/min
Nominal flow Qn [l/min]	5m	130 l/min	130 l/min	140 l/min
Nominal flow Qn [l/min]	6m	115 l/min	120 l/min	130 l/min
Nominal flow Qn [l/min]	7m	105 l/min	115 l/min	120 l/min
Nominal flow Qn [l/min]	8m	100 l/min	110 l/min	110 l/min
Nominal flow Qn [l/min]	9m	95 l/min	100 l/min	105 l/min
Nominal flow Qn [l/min]	10m	90 l/min	95 l/min	100 l/min

PUN-H-8x0,75-SW				
Inner diameter: 5.5mm				
Input pressure P1	length	5,0 bar	6,0 bar	6,5 bar
Output pressure P2		4,0 bar	5,0 bar	5,5 bar
Nominal flow Qn [l/min]	1m	580 l/min	640 l/min	670 l/min
Nominal flow Qn [l/min]	2m	440 l/min	480 l/min	500 l/min
Nominal flow Qn [l/min]	3m	370 l/min	400 l/min	420 l/min
Nominal flow Qn [l/min]	4m	320 l/min	350 l/min	360 l/min
Nominal flow Qn [l/min]	5m	290 l/min	310 l/min	330 l/min
Nominal flow Qn [l/min]	6m	260 l/min	290 l/min	300 l/min
Nominal flow Qn [l/min]	7m	240 l/min	270 l/min	280 l/min
Nominal flow Qn [l/min]	8m	230 l/min	250 l/min	260 l/min
Nominal flow Qn [l/min]	9m	210 l/min	230 l/min	240 l/min
Nominal flow Qn [l/min]	10m	200 l/min	220 l/min	230 l/min

PUN-H-10x1,5-SW				
内径: 7mm				
Input pressure P1	length	5,0 bar	6,0 bar	6,5 bar
Output pressure P2		4,0 bar	5,0 bar	5,5 bar
Nominal flow Qn [l/min]	1m	1050 l/min	1150 l/min	1200 l/min
Nominal flow Qn [l/min]	2m	810 l/min	890 l/min	920 l/min
Nominal flow Qn [l/min]	3m	690 l/min	750 l/min	780 l/min
Nominal flow Qn [l/min]	4m	600 l/min	650 l/min	680 l/min
Nominal flow Qn [l/min]	5m	540 l/min	590 l/min	610 l/min
Nominal flow Qn [l/min]	6m	490 l/min	540 l/min	560 l/min
Nominal flow Qn [l/min]	7m	460 l/min	500 l/min	520 l/min
Nominal flow Qn [l/min]	8m	430 l/min	470 l/min	490 l/min
Nominal flow Qn [l/min]	9m	400 l/min	440 l/min	460 l/min
Nominal flow Qn [l/min]	10m	380 l/min	420 l/min	430 l/min

PUN-H-12x2-SW				
Inner diameter: 8mm				
Input pressure P1	length	5,0 bar	6,0 bar	6,5 bar
Output pressure P2		4,0 bar	5,0 bar	5,5 bar
Nominal flow Qn [l/min]	1m	1450 l/min	1590 l/min	1650 l/min
Nominal flow Qn [l/min]	2m	1140 l/min	1240 l/min	1290 l/min
Nominal flow Qn [l/min]	3m	960 l/min	1050 l/min	1090 l/min
Nominal flow Qn [l/min]	4m	850 l/min	920 l/min	960 l/min
Nominal flow Qn [l/min]	5m	760 l/min	830 l/min	870 l/min
Nominal flow Qn [l/min]	6m	700 l/min	760 l/min	800 l/min
Nominal flow Qn [l/min]	7m	650 l/min	710 l/min	740 l/min
Nominal flow Qn [l/min]	8m	610 l/min	660 l/min	690 l/min
Nominal flow Qn [l/min]	9m	580 l/min	630 l/min	650 l/min
Nominal flow Qn [l/min]	10m	550 l/min	600 l/min	620 l/min

PUN-H-14x2-SW				
Inner diameter: 10mm				
Input pressure P1	length	5,0 bar	6,0 bar	6,5 bar
Output pressure P2		4,0 bar	5,0 bar	5,5 bar
Nominal flow Qn [l/min]	1m	2450 l/min	2680 l/min	2790 l/min
Nominal flow Qn [l/min]	2m	1970 l/min	2150 l/min	2240 l/min
Nominal flow Qn [l/min]	3m	1690 l/min	1840 l/min	1920 l/min
Nominal flow Qn [l/min]	4m	1500 l/min	1630 l/min	1700 l/min
Nominal flow Qn [l/min]	5m	1360 l/min	1480 l/min	1540 l/min
Nominal flow Qn [l/min]	6m	1250 l/min	1360 l/min	1420 l/min
Nominal flow Qn [l/min]	7m	1160 l/min	1270 l/min	1320 l/min
Nominal flow Qn [l/min]	8m	1090 l/min	1190 l/min	1240 l/min
Nominal flow Qn [l/min]	9m	1030 l/min	1120 l/min	1170 l/min
Nominal flow Qn [l/min]	10m	980 l/min	1070 l/min	1110 l/min

PUN-H-16x2,5-SW				
Inner diameter: 11mm				
Input pressure P1	length	5,0 bar	6,0 bar	6,5 bar
Output pressure P2		4,0 bar	5,0 bar	5,5 bar
Nominal flow Qn [l/min]	1m	3050 l/min	3340 l/min	3480 l/min
Nominal flow Qn [l/min]	2m	2490 l/min	2720 l/min	2830 l/min
Nominal flow Qn [l/min]	3m	2140 l/min	2340 l/min	2430 l/min
Nominal flow Qn [l/min]	4m	1910 l/min	2080 l/min	2160 l/min
Nominal flow Qn [l/min]	5m	1730 l/min	1890 l/min	1960 l/min
Nominal flow Qn [l/min]	6m	1600 l/min	1740 l/min	1810 l/min
Nominal flow Qn [l/min]	7m	1490 l/min	1620 l/min	1690 l/min
Nominal flow Qn [l/min]	8m	1400 l/min	1520 l/min	1580 l/min
Nominal flow Qn [l/min]	9m	1320 l/min	1440 l/min	1500 l/min
Nominal flow Qn [l/min]	10m	1260 l/min	1370 l/min	1420 l/min

Tubing Parker 3/8"				
Inner diameter: 9.5mm				
Input pressure P1	length	5,0 bar	6,0 bar	6,5 bar
Output pressure P2		4,0 bar	5,0 bar	5,5 bar
Nominal flow Qn [l/min]	1m	2170 l/min	2380 l/min	2470 l/min
Nominal flow Qn [l/min]	2m	1740 l/min	1900 l/min	1970 l/min
Nominal flow Qn [l/min]	3m	1490 l/min	1620 l/min	1690 l/min
Nominal flow Qn [l/min]	4m	1320 l/min	1440 l/min	1490 l/min
Nominal flow Qn [l/min]	5m	1190 l/min	1300 l/min	1350 l/min
Nominal flow Qn [l/min]	6m	1090 l/min	1190 l/min	1240 l/min
Nominal flow Qn [l/min]	7m	1020 l/min	1110 l/min	1150 l/min
Nominal flow Qn [l/min]	8m	950 l/min	1040 l/min	1080 l/min
Nominal flow Qn [l/min]	9m	900 l/min	980 l/min	1020 l/min
Nominal flow Qn [l/min]	10m	860 l/min	930 l/min	970 l/min

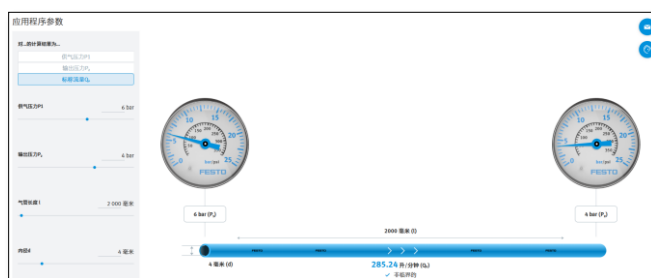

4 Status LEDs of the energy efficiency module „C2M“

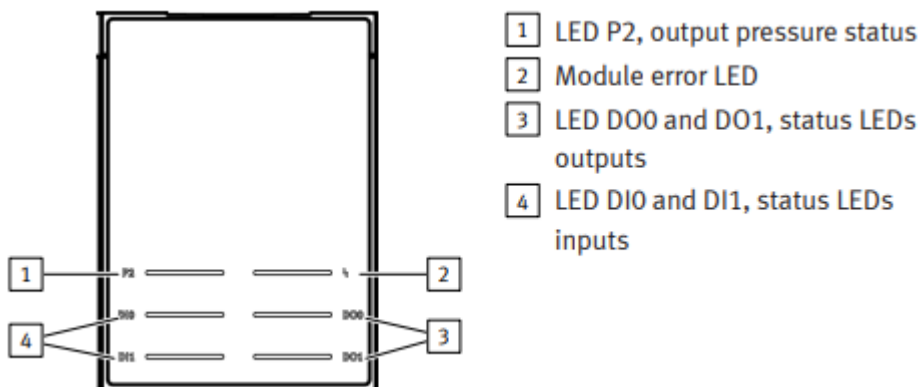

LED	Meaning	
P2 (green)		
	LED on	Outlet pressure p2 ≥ lower critical limit pressure p2
	LED flashes	Outlet pressure p2 < lower critical limit pressure p2 and Output pressure p2 ≥ auto standby pressure setpoint value – 0.05 MPa (0.5 bar; 7.25 psi)
	LED is off	Output pressure p2 < auto standby pressure setpoint value – 0.05 MPa (0.5 bar; 7.25 psi)
DIO and DI1, green		
	LED on	Signal at electrical input 0 or 1 is pending, logic 1
	LED is off	Signal at electrical input 0 or 1 is not pending, logic 0
D00 and DI1 (yellow)		
	LED on	Electrical output 0 or 1 sends 1-signal, logic 1
	LED is off	Electrical output 0 or 1 sends 0-signal, logic 0
red		
	LED on	Module error
	LED is off	No module error

5 Interfaces and display components on the bus node FB 44

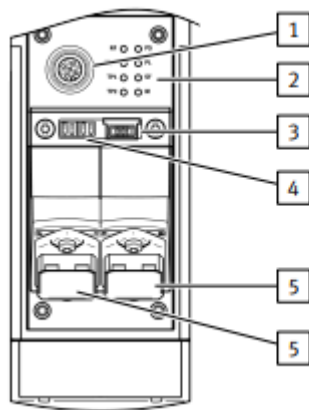

- 1 Service interface
- 2 Network-specific and CPX-specific LEDs
- 3 Memory card, under a cover
- 4 DIL switch, under a cover
- 5 Network connection, example CPX-FB44
- 5 Network connection, example CPX-FB44

LED displays on the bus node CPX-M-FB44

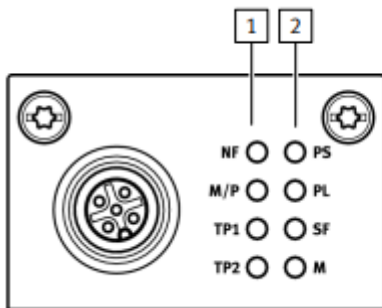

- 1 Network-specific LEDs
- 2 CPX-specific LEDs

Network-specific LEDs ¹⁾		CPX-specific LEDs ²⁾	
NF	Network failure, red	PS	Power system, green
M/P	Maintenance/PROFenergy, green	PL	For MSE6-C2M without function.
TP1	Link 1, green	ST	System failure, red
TP2	Link 2, green	M	Modify, yellow ³⁾

1) Without network connection, the LED NF flashes.

2) In normal operating status, all green LEDs light up. The yellow and red LEDs are not on.

3) Parameterisation modified or force active.

6 BMW SAS Module

BMW GSC Standard

For the C2M energy efficiency module, BMW PLC provides standard modules for control integration into the BMW system environment. This module controls the media unit according to the system's operating mode.

Titel : **MEDIA_MS_6_FB**

Comment :

Monitoring compressed air in the Festo maintenance unit C2M 6 bar

Supporting Hardware: Festo MSE6-C2M (6 bar)

Funktionalität: Monitoring compressed air in the Festo maintenance unit

Titel : **MEDIA_MS_6_12_FB**

Comment :

Medien 6 bar /Cooling water

Supporting Hardware: Festo MSE6-C2M (6 bar)

