

快插接头 QS, 标准

FESTO



Festo 核心产品范围
涵盖您大多数的自动化应用

全球:
好用:
快捷:

快速交付
一如既往的 Festo 质量水准
快捷选型

通过 Festo 核心产品范围, 我们从我们庞大的产品目录中, 精选了最重要的产品和功能, 并能快速交付。

核心产品范围为您的自动化应用带来最佳价值。

只要找到
这个星星!

主要特性

应用



轻松选择合适的接头。Festo 为每一个连接提供可靠的解决方案。便利的快插接头系统包括1000多个型号的标准和功能性接头。

气管/接头组合概览	接头	气管	简要说明
常规	QS(M)	PUN-H	适合各种类型的任务，且价格优惠。采用高抗性材料，弹性佳，弯曲半径经过优化，便于安装。在动态应用场合中具备高耐磨性。
	QS(M)	PEN	拥有多种不同型号的组合选择，因此，在各种标准应用场合中具备极高的灵活性。
	QS(M)	PAN	可满足所有要求，甚至适用于压力和温度范围均有所增大的标准应用场合。
高压力	NPQM	PAN-MF	符合 DIN 标准 73378: 非常适合用于移动气动元件。适用于压力范围大且温度范围更大的应用场合。
	NPQH	PAN-R	功能强大，最大压力达 20 bar，例如，在使用增压器 DPA 的应用场合中。
耐化、耐水解、食品安全	NPQP	PLN	耐清洁剂，符合 FDA 规定，且经济实惠。可代替不锈钢接头组合。
	NPKA	PUN-H	耐水解，适合有水应用。组合适用于洁净室中，符合 FDA 规定，采用 100% 聚合物制成，耐腐蚀。采用“一卡到位原则”，非常易于安装。
	NPQH	PFAN/PTFEN	用于高达 150 °C 的高温环境中。食品级，符合 FDA 规定，且耐清洁剂。
	NPCK	PFAN/PTFEN	采用管接螺母无边设计，易于清洁。非常耐腐蚀 (CRC 4)，且符合 FDA 规定。适合多种介质。
耐化、耐水解	NPQR	PFAN/PTFEN	经过优化的无边设计，不易积灰，食品级 - 价格优惠。可用于高达 150 °C 的高温环境中。最大压力达 16 bar。达到最高耐腐蚀等级 (CRC 4)。
抗静电	NPQM	PUN-CM	抗静电气管与坚固的金属接头组合：最大程度地保护电气和电子元件。
阻燃	NPQM	PUN-V0	因具备阻燃性，在存在火灾风险的场合使用非常安全。已根据 DIN 5510-2 对气管进行测试。
耐焊渣	NPQH	PUN-V0-C	非常适合存在焊渣的应用场合。所有直径的气管壁厚均为 2 mm，非常可靠。
	QS-V0	PAN-V0	采用有特殊接头的双壁气管，即便近距离接触焊渣，仍可确保安全。

主要特性

快插接头产品范围

QSM, mini

技术参数 → Internet: qsm



小型快插接头用于在局促的安装空间内实现最大的元件密度。用于最高温度达 80°C、最大压力达 14 bar 的气动应用场合。适用气管外径包括 2, 3, 4 和 6 mm, 可配合连接螺纹: M3, M5, M6, M7, R1/8 和 G1/8。

QS, 标准

技术参数 → Internet: qs



多种快插接头选择, 用于最高温度达 80°C、最大压力达 14 bar 的气动应用场合。适用气管外径包括 4, 6, 8, 10, 12, 16 和 22 mm, 可配合连接螺纹: R1/8 ... R1/2 和 G1/8 ... G3/4。

QS-V0, 耐焊渣

技术参数 → Internet: qs-v0



阻燃型快插接头适用于所有存在火灾风险的场合, 例如, 汽车行业和建筑行业中的焊接系统。用于最高温度达 60°C、最大压力达 10 bar 的气动应用场合。适用气管外径包括 4, 6, 8, 10 和 12 mm, 可配合连接螺纹: R1/8 ... R1/2 和 G1/8 ... G1/2。

NPQH

技术参数 → Internet: npqh



坚固的金属快插接头均为镀镍黄铜(采用化学方法)材质。高耐腐蚀等级 CRC 3, 且耐化学品。用于最高温度达 150°C、最大压力达 20 bar 的气动应用场合。适用气管外径包括 4, 6, 8, 10, 12 和 14 mm, 可配合连接螺纹: M5, M7 和 G1/8 ... G1/2。

NPQM

技术参数 → Internet: npqm



价格实惠的金属快插接头, 用于最高温度 70°C、最大压力达 16 bar 的气动应用场合。适用气管外径包括 3, 4, 6, 8, 10, 12 和 14 mm, 可配合连接螺纹: M5, M7 和 G1/8 ... G1/2。

NPQP

技术参数 → Internet: npqp



聚丙烯接头, 用于受介质影响严重的应用场合中。用于最高温度达 60°C、最大压力达 10 bar 的气动应用场合。适用气管外径包括 4, 6, 8, 10 和 12 mm, 可配合连接螺纹: R1/8 ... R1/2。

NPQR, 不锈钢

技术参数 → Internet: npqr



不锈钢快插接头。最高耐腐蚀等级 CRC 4, 且耐化学品。食品级, 可用于食品包装行业。用于最高温度达 150°C、最大压力达 16 bar 的气动应用场合。适用气管外径包括 4, 6, 8, 10 和 12 mm, 可配合连接螺纹: M5, M7 和 G1/8 ... G1/2。

主要特性

功能性快插接头产品范围

QSK,
快插接头, 自密封

技术参数 → Internet: qsk



气管断开后, 阻断气流的快插接头。用于最高温度达 60°C、最大压力达 14 bar 的气动应用场合。适用气管外径包括 4, 6, 8, 10 和 12 mm, 可配合连接螺纹: M5, R1/8 ... R1/2 和 G1/8 ... G1/2。

QSR,
快插接头, 可旋转

技术参数 → Internet: qsr



快插接头, 带旋转接口, 可旋转 360°。滚珠轴承在旋转运动场合中最大转速可达 500 rpm。用于最高温度达 60°C、最大压力达 14 bar 的气动应用场合。适用气管外径包括 4, 6, 8, 10 和 12 mm, 可配合连接螺纹: M5, R1/8 ... R1/2 和 G1/8 ... G1/2

快拧接头产品范围

NPCK

技术参数 → Internet: npck



不锈钢接头, 用于频繁清洗的场合。最高耐腐蚀等级 (CRC 4)。用于最高温度达 120°C、最大压力达 12 bar 的气动应用场合。适用气管外径包括 4, 6, 8 和 10 mm, 可配合连接螺纹: M5 和 G1/8 ... G3/8。

卡扣式接头产品范围

NPKA

技术参数 → Internet: npka



塑料接头, 可单手安装。耐水解, 符合 FDA 规定, 易于清洁。用于最高温度达 60°C、最大压力达 10 bar 的气动应用场合。适用气管外径包括 6 mm, 可配合连接螺纹: G1/8。

方便的“即插即用”

不锈钢夹紧鄂牢固地夹持住气管而不会损坏气管的表面。可吸收振动和压力冲击。

可靠连接

一个丁腈橡胶密封圈确保了标准气管和接头之间的完美密封。标准外径气管与 Festo 快插接头的组合适用于压缩空气和真空。

防掉密封件

Festo 快插接头的所有黄铜部分都有镀镍表面, 所以有较高的耐腐蚀等级。锥形 ISO R 螺纹采用自密封的聚四氟乙烯涂层, 让接头可重复使用五次, 而无需额外的密封件。

可旋转

接头安装后, 可重新定向。

主要特性

哪类接头配合哪类螺纹?

公制螺纹

- 兼容 G 螺纹, 作为柱形公制螺纹安装
- 因为 O 型圈位于槽内, 紧贴气管密封, 所以保证了密封性

G 螺纹, 符合 ISO 228-1

- 螺纹更短
- 安装深度恒定
- 密封圈可更换
- 正面密封
- 密封圈可更换, 可重复使用数次

R 螺纹, 符合 EN 10226-1 和 ISO 7/1

- 自密封螺纹
- 通过涂层螺纹密封
- 无需额外的密封面
- 无需密封面的补差, 安装尺寸更小
- 最多可重复使用 5 次

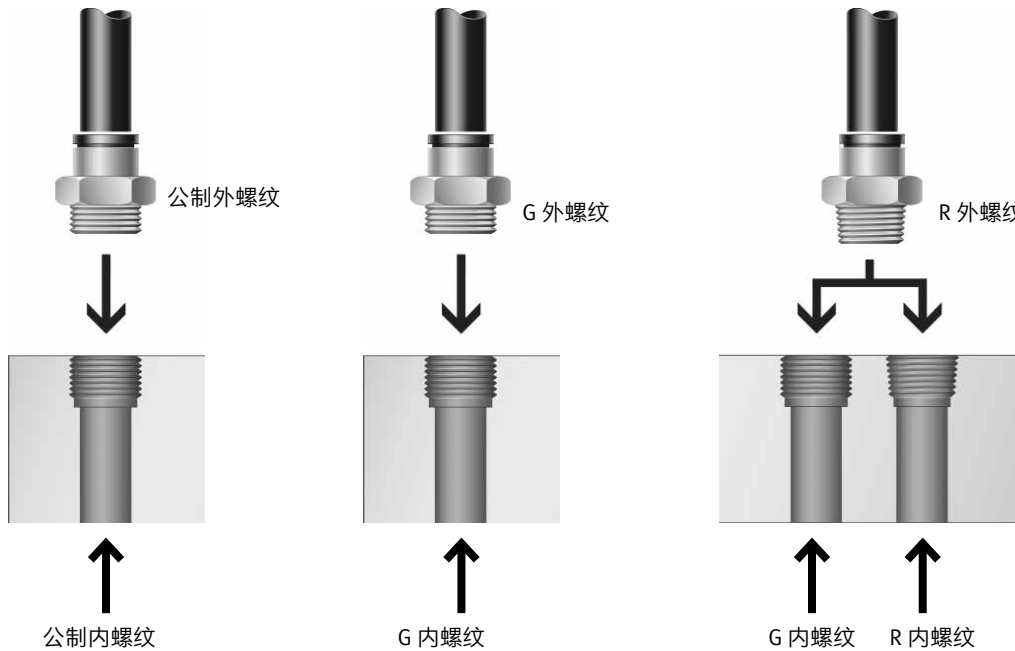

- 注意

如果 R 外螺纹与 G 内螺纹组合, G 内螺纹如果生产时没有清洁或超出许用公差, 就会发生泄漏。因此, 这种组合需要使用额外的密封件, 如密封带。

- 注意

所有 R 螺纹带有密封材料涂层, 以代替传统的密封圈。手动用开口扳手将接头拧入 R 螺纹 1 或 2 圈。接头最多能像这样重复拧紧五次。

当多次拧入 R 螺纹时, 您必须确保, 磨下来的密封材料涂层颗粒不会进入压缩空气系统。

主要特性

气管插拔

要确保牢固固定内部密封件并使其免受损坏，气管的切割断面必须平整，并除去毛刺。

1) 将气管插到底。

确保将气管插入内部密封件至关重要。根据气管和密封件的公差位置，气管与密封件的接触可能会被误认为已插到底部。

2) 轻轻拉动气管，检查气管接头是否固定牢固。

拔

1) 向下按住解锁环即可轻松拆下气管。小心地从螺纹接头拆下气管。

2) 在重新使用气管前，应切掉损坏的部分。

技术参数

主要技术参数	
结构特点	推挽式
安装位置	任意
螺纹部分密封方式	密封圈, 用于 G 螺纹 涂层, 用于 R 螺纹
额定紧固扭矩 [Nm]	1.2 ±20%, 用于 M5 外螺纹 5.4 ±20%, 用于 G1/8 外螺纹 9 ±20%, 用于 G1/4 外螺纹 15.5 ±20%, 用于 G3/8 外螺纹 26 ±20%, 用于 G1/2 外螺纹 20 ±20%, 用于 G3/4 外螺纹
气管插入深度 ¹⁾ [mm]	15, 气管外径 4 mm (12 用于 QSW) 17, 气管外径 6 mm (12 用于 QSW) 18, 气管外径 8 mm 20.5, 气管外径 10 mm 23.5, 气管外径 12 mm 24.5, 气管外径 16 mm 28, 气管外径 22 mm

1) 表中所示气管插入深度是参考值, 取决于型号可能稍微有些差异。

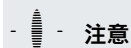

注意

使用带内六角快插接头时, 紧固时不要将内六角扳手插入太深, 以避免损坏接头后面的元件。

工作和环境条件		QS-G3/4-22 除外	QS-G3/4-22
型号			
工作压力, 用于整个温度范围	[MPa]	-0.095 ... +0.6	-0.095 ... +1.4
	[bar]	-0.95 ... +6	-0.95 ... +14
	[psi]	-13.775 ... +87	-13.775 ... +203
由温度决定的工作压力	[MPa]	-0.095 ... +1.4 → 图表	-0.095 ... +1.4
	[bar]	-0.95 ... +14	-0.95 ... +14
	[psi]	-13.775 ... +203	-13.775 ... +203
工作压力注意事项	水: max. 50°C 时 max. 0.6 MPa		
工作介质	压缩空气, 符合 ISO 8573-1:2010 [7:-:-] 水 (液态, 无冰) ¹⁾		
工作/先导介质注意事项	可用润滑介质 水: G 螺纹仅可配合 OL 密封圈 ²⁾		
环境温度 [°C]	-10 ... +80	-20 ... +80	
耐腐蚀等级 CRC ³⁾	1 - 低耐腐蚀能力		

1) 详见: www.festo.com/catalogue/qs → Support/Downloads

2) 交付时 G 螺纹上的的密封圈必须用密封圈 OL 替换掉 → Internet: ol

3) 详见: www.festo.com/x/topic/kbk

技术参数

工作压力 p 与温度 t 的关系 (QS-G3/4-22 除外)

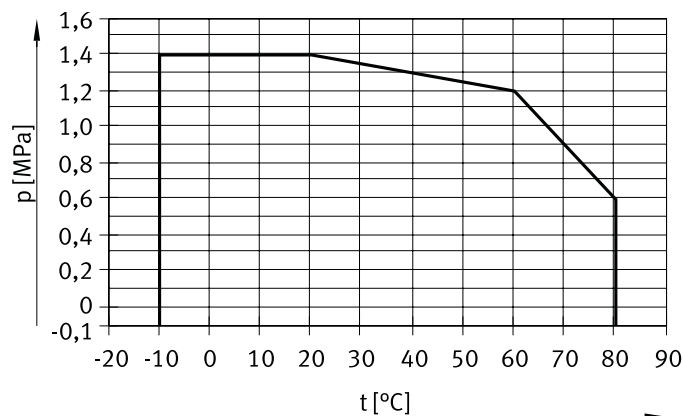

材料

剖面图

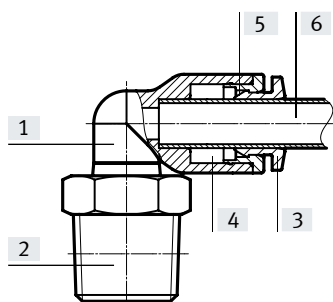

型号	QS, 标准
[1] 壳体	镀镍黄铜, PBT, 阳极氧化铝
[2] 螺纹颈	镀镍黄铜
[3] 解锁环	POM (蓝色)
[4] 气管密封件	NBR
[5] 气管夹紧段	高合金不锈钢
[6] 塑料气管, 标准外径	PUN-H, PEN, PAN
[-] 螺母 (QSS/QSSF)	镀镍黄铜
[-] 中空螺母 (QSLV/QSTF/QSYLV)	镀镍黄铜
材料注意事项	RoHS 合规
油漆湿润缺陷物质标准	VDMA24364-B1/B2-L
洁净室等级 ¹⁾	等级 4, 按 ISO 14644-1

1) 按 ISO 14644-1 标准, 对于插入是轴套 QSH 和堵头 QSC...H (固定安装元件) 的测试没有意义。









快插接头/气管可用组合

螺纹	气管外径 [mm]						
	4	6	8	10	12	16	22
M5	++	+	-	-	-	-	-
R1/8	+	++	+	+	-	-	-
R1/4	+	+	++	+	+	-	-
R3/8	-	+	+	++	+	+	-
R1/2	-	-	-	+	++	+	-
G1/8	+	++	+	+	-	-	-
G1/4	+	+	++	+	+	-	-
G3/8	-	+	+	++	+	+	-
G1/2	-	-	-	-	++	+	-
G3/4	-	-	-	-	-	-	++

+ 螺纹/气管外径可用组合



++ 螺纹/气管外径最优组合 (针对流量)

产品范围一览

结构特点	结构特点	型号	接口 D1				接口 D2			→ 页码
			M 螺纹	R 螺纹	G 螺纹	气管外径	插入式轴套 Ø	气管外径	插入式轴套 Ø	
直列式	快插接头 – 外螺纹, 带外六角									
		QS	-	R1/8	G1/8	-	-	4, 6, 8, 10 ¹⁾	-	14
				R1/4	G1/4			4 ¹⁾ , 6, 8, 10, 12		
				R3/8	G3/8			6 ¹⁾ , 8, 10, 12, 16		
				R1/2	G1/2			10 ¹⁾ , 12, 16		
				-	G3/4			22		
	快插接头 – 外螺纹, 带内六角									
		QS-...-I	-	R1/8	G1/8	-	-	4, 6, 8, 10	-	17
				R1/4	G1/4			6, 8, 10, 12 ¹⁾		
				R3/8	G3/8			8, 10, 12		
				R1/2	G1/2			10 ¹⁾ , 12		
	快插接头 – 内螺纹, 带外六角									
	QSF	-	-	G1/8	-	-	4, 6, 8	-	19	
				G1/4			4, 6, 8, 10, 12			
				G3/8			6, 8, 10, 12			
				G1/2			12, 16			
快插接头										
	QS	-	-	-	4	-	4	-	20	
					6		6			
					8		8			
					10		10			
					12		12			
	QS 变径	-	-	-	6	-	4	-	20	
					8		4, 6			
					10		6, 8			
					12		8, 10			
穿板式快插接头										
	QSS	-	-	-	4	-	-	-	21	
					6					
					8					
					10					
					12					
穿板式快插接头, 带固定颈圈										
	QSS-...-F	-	-	-	4	-	-	-	21	
					6					
					8					
					10					
					12					
穿板式快插接头, 带内螺纹										
	QSSF	-	-	G1/8	-	-	4, 6, 8	-	22	
				G1/4			4, 6, 8, 10			
				G3/8			6, 8, 10, 12			
				G1/2			12, 16			



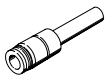
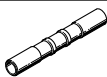
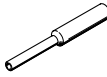
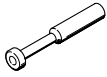



1) 仅可组合 R 螺纹

产品范围一览







结构特点	结构特点	型号	接口 D1				接口 D2			→ 页码	
			M 螺纹	R 螺纹	G 螺纹	气管外径	插入式轴套 ∅	气管外径	插入式轴套 ∅		
直列式	快插堵头	QSC	-	-	-	4	-	-	-	23	
			6	-	-	-	-	-			
			8	-	-	-	-	-			
			10	-	-	-	-	-			
			12	-	-	-	-	-			
	快插接头, 带插入式轴套										
		QS-...H	-	-	-	-	6	4	-	24	
							8	4, 6			
							10	6, 8			
							12	6, 8, 10			
插入式轴套											
	QSH	-	-	-	-	4	-	-	25		
						6					
						8					
						10					
						12					
	QSH 变径	-	-	-	-	6	-	4	25		
						8		4, 6			
						10		6, 8			
						12		8, 10			
						16		12			
堵头											
	QSC-...H	-	-	-	-	4	-	-	26		
						6					
						8					
						10					
						12					
L型	L型快插接头 - 外螺纹, 带外六角, 可旋转										
		QSL	-	R1/8	G1/8	-	-	4, 6, 8, 10 ¹⁾	-	27	
				R1/4	G1/4			4 ¹⁾ , 6, 8, 10, 12			
				R3/8	G3/8			6 ¹⁾ , 8, 10, 12, 16			
				R1/2	G1/2			10 ¹⁾ , 12, 16			
	L型快插接头, 长 - 外螺纹, 带外六角, 可旋转										
		QSL	-	R1/8	G1/8	-	-	4, 6, 8	-	29	
				R1/4	G1/4			4 ¹⁾ , 6, 8, 10, 12 ²⁾			
				R3/8	G3/8			6 ¹⁾ , 8, 10, 12			
				R1/2	G1/2			10 ¹⁾ , 12, 16 ²⁾			

1) 仅可组合 R 螺纹
2) 仅可组合 G 螺纹

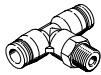
产品范围一览

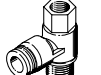

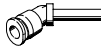



结构特点	结构特点	型号	接口 D1				接口 D2			→ 页码
			M 螺纹	R 螺纹	G 螺纹	气管外径	插入式轴套 ∅	气管外径	插入式轴套 ∅	
L 型	L 型快插接头 – 内螺纹, 带外六角, 可旋转									
		QSLF	-	-	G1/8	-	-	4, 6, 8	-	31
					G1/4			6, 8, 10		
					G3/8			8, 10		
	L 型快插接头 – 外螺纹, 带内六角, 可旋转									
		QSLV-...-I	-	R1/8	G1/8	-	-	6, 8	-	32
				R1/4	G1/4			6, 8, 10		
				R3/8	G3/8			8, 10, 12		
				R1/2	G1/2			12		
	L 型快插接头 – 外螺纹, 带外六角, 可旋转									
		QSLV	M5	-	-	-	-	6	-	33
				R1/8	G1/8	-	-	4, 6, 8	-	
				R1/4	G1/4			6, 8, 10		
				R3/8	G3/8			8, 10, 12		
				R1/2	G1/2			12, 16		
L 型快插接头										
	QSL	-	-	-	4	-	-	-	35	
					6					
					8					
					10					
					12					
					16					
L 型快插接头, 带插入式轴套										
	QSL-...H	-	-	-	-	4	4	-	36	
						6	6			
						8	8			
						10	10			
						12	12			
	QSL-...H 变径	-	-	-	-	6	4	-	36	
						8	6			
						10	8			
						12	10			
	QSL-...HL 长插入式轴套	-	-	-	-	4	4	-	36	
						6	6			
						8	8			
						10	10			
						12	12			

产品范围一览

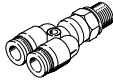
结构特点	结构特点	型号	接口 D1				接口 D2		→ 页码	
			M 螺纹	R 螺纹	G 螺纹	气管外径	插入式轴套 ∅	气管外径		插入式轴套 ∅
T型	T 型快插接头 – 外螺纹, 带外六角, 可旋转									
		QST	-	R1/8	G1/8	-	-	4, 6, 8, 10 ¹⁾	-	37
				R1/4	G1/4			4 ¹⁾ , 6, 8, 10, 12		
				R3/8	G3/8			6 ¹⁾ , 8, 10, 12, 16		
				R1/2	G1/2			10 ¹⁾ , 12, 16		
T 型快插接头										
	QST	-	-	-	-	-	4	-	39	
							6			4
							8			6
							10			8
							12			10
	16	12								
	16	16								
	QST 变径	-	-	-	-	-	6	-	39	
							8			4, 6
							10			6, 8
							12			8, 10
							16			12
T 型快插接头 – 外和内螺纹, 带外六角, 可旋转										
	QSTF	-	R1/8	G1/8	-	-	4, 6, 8	-	40	
			R1/4	G1/4			6, 8, 10			
			R3/8	G3/8			8, 10, 12			
			R1/2	G1/2			12			
T 型快插接头 – 外螺纹, 带外六角, 可旋转										
	QSTL	-	R1/8	G1/8	-	-	4, 6, 8	-	41	
			R1/4	G1/4			6, 8, 10			
			R3/8	G3/8			8, 10, 12			
			R1/2	G1/2			12, 16			
弯角 45°	快插接头 – 外螺纹, 带外六角, 可旋转									
		QSW	-	R1/8	-	-	-	4, 6, 8	-	43
	R1/4			6, 8, 10						
	R3/8			10, 12						
	R1/2			12, 16						
快插接头, 带插入式轴套										
	QSW-...HL	-	-	-	-	-	4	-	44	
							6			4
							8			6
							10			8
							12			10
	12	12								
X 型	X 型快插接头									
		QSX	-	-	-	-	-	8	-	44
	10									
	12									

1) 仅可组合 R 螺纹

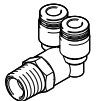
产品范围一览

结构特点	结构特点	型号	接口 D1				接口 D2			→ 页码	
			M 螺纹	R 螺纹	G 螺纹	气管外径	插入式轴套 Ø	气管外径	插入式轴套 Ø		
Y 型	Y 型快插接头 – 外螺纹, 带外六角, 可旋转										
		QSY	M5	–	–	–	–	–	4, 6	–	45
			–	R1/8	G1/8	–	–	–	4, 6, 8	–	
			–	R1/4	G1/4	–	–	–	4 ¹⁾ , 6, 8, 10	–	
			–	R3/8	G3/8	–	–	–	8, 10, 12	–	
			–	R1/2	G1/2	–	–	–	10 ¹⁾ , 12	–	
	Y 型快插接头										
		QSY	–	–	–	4	–	4	–	47	
			–	–	–	6	–	6	–		
			–	–	–	8	–	8	–		
			–	–	–	10	–	10	–		
			–	–	–	12	–	12	–		
	QSY 变径	–	–	–	6	–	4	–	47		
		–	–	–	8	–	4, 6	–			
		–	–	–	10	–	6, 8	–			
		–	–	–	12	–	8, 10	–			
		–	–	–	16	–	12	–			
Y 型快插接头, 带插入式轴套											
	QSY...H(-B)	–	–	–	–	–	4	4	–	48	
		–	–	–	–	–	6	6	–		
		–	–	–	–	–	8	8	–		
		–	–	–	–	–	10	10	–		
		–	–	–	–	–	12	12	–		
	QSY...H(-B) 变径	–	–	–	–	–	6	4	–	48	
		–	–	–	–	–	8	6	–		
		–	–	–	–	–	10	8	–		
		–	–	–	–	–	12	10	–		
		–	–	–	–	–	–	–	–		–
Y 型快插接头 – 外螺纹, 带外六角, 可旋转											
	QSYL	–	R1/8	G1/8	–	–	–	4, 6, 8	–	49	
		–	R1/4	G1/4	–	–	–	6, 8, 10	–		
		–	R3/8	G3/8	–	–	–	8, 10, 12	–		
		–	R1/2	G1/2	–	–	–	12	–		
		–	–	–	–	–	–	–	–		–
Y 型快插接头 – 外螺纹, 带外六角, 可旋转											
	QSYLV	–	R1/8	G1/8	–	–	–	6	–	50	
		–	R1/4	G1/4	–	–	–	8	–		
		–	R3/8	G3/8	–	–	–	10	–		
		–	R1/2	G1/2	–	–	–	12	–		
		–	–	–	–	–	–	–	–		–
解锁工具	快拔解锁工具, 用于快插接头										
		QSO	–	–	–	–	–	–	–	–	51

1) 仅可组合 R 螺纹

技术参数

快插接头 QS
外螺纹, 带外六角

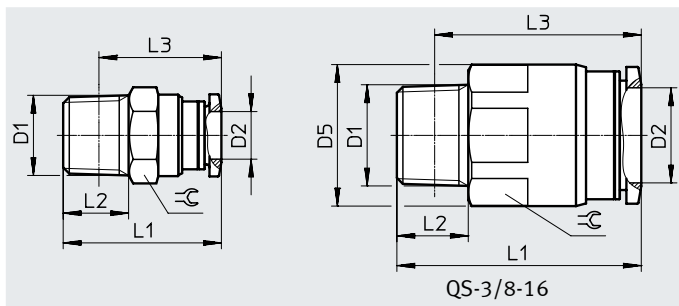

尺寸和订货数据											
气接口		公称通径 [mm]	尺寸 [mm]					重量/件 [g]	订货号	型号	PS ¹⁾
外螺纹 D1	适用气管外径 D2		D5	L1	L2	L3	⌀				
R 螺纹											
R1/8	4	3	-	21	8	17	10	7.4	★ 153001	QS-1/8-4	10
									130674	QS-1/8-4-100	100
	6	5	-	22.3	8	18.3	12	8.2	★ 153002	QS-1/8-6	10
									130675	QS-1/8-6-100	100
	8	6	-	27.9	8	23.9	14	14	★ 153004	QS-1/8-8	10
									130676	QS-1/8-8-50	50
	10	6	-	30.3	8	26.3	17	21	★ 190643	QS-1/8-10	10
R1/4	4	3	-	22.5	11	16.5	14	16	★ 190644	QS-1/4-4	10
	6	5	-	23.7	11	17.6	14	15	★ 153003	QS-1/4-6	10
									130677	QS-1/4-6-100	100
	8	7	-	26.6	11	20.6	14	14	★ 153005	QS-1/4-8	10
									130678	QS-1/4-8-50	50
	10	8.5	-	29.8	11	23.8	17	19	★ 153007	QS-1/4-10	10
								130679	QS-1/4-10-50	50	
	12	8.5	-	35.9	11	29.9	21	37	★ 164980	QS-1/4-12	10
									130680	QS-1/4-12-20	20
R3/8	6	5	-	24.5	12	18.1	17	28	★ 190645	QS-3/8-6	10
	8	7	-	25.5	12	19.2	17	25	★ 153006	QS-3/8-8	10
									130681	QS-3/8-8-50	50
	10	9	-	29.3	12	23	17	24	★ 153008	QS-3/8-10	10
									130682	QS-3/8-10-50	50
	12	11	-	31.9	12	25.6	21	30	★ 153009	QS-3/8-12	10
								130683	QS-3/8-12-20	20	
	16	11	23.8	41.1	12	34.8	22	50	164957	QS-3/8-16	1
R1/2	10	9	-	30.4	15	22.2	21	46	★ 190646	QS-1/2-10	1
									133189	QS-1/2-10-50	50
	12	11	-	33.9	15	25.7	21	44	★ 153010	QS-1/2-12	1
									130684	QS-1/2-12-20	20
	16	13	-	41.3	15	33.1	24	63	153011	QS-1/2-16	1
								130685	QS-1/2-16-20	20	

1) 每包数量

技术参数

快插接头 QS

外螺纹, 带外六角

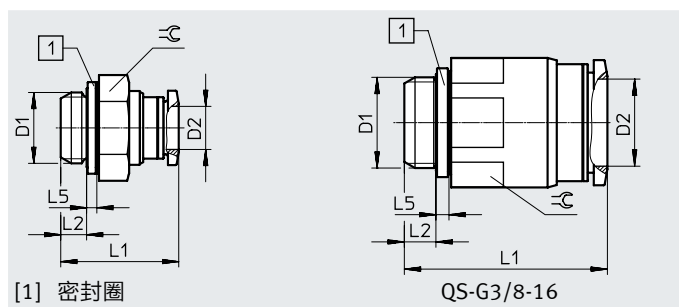

尺寸和订货数据										
气接口		公称通径 [mm]	尺寸 [mm]				重量/件 [g]	订货号	型号	PS ¹⁾
外螺纹 D1	适用气管外径 D2		L1	L2	L5	⌀				
G 螺纹, 带密封圈										
G1/8	4	3	19.5	4.2	1.9	13	9.1	★ 186095	QS-G1/8-4	10
		132036	QS-G1/8-4-100	100						
	6	5	20.6	4.2	1.9	13	8.3	★ 186096	QS-G1/8-6	10
		132037	QS-G1/8-6-100	100						
8	6	25.8	4.2	1.9	14	13	★ 186098	QS-G1/8-8	10	
	132038	QS-G1/8-8-50	50							
G1/4	6	5	21.2	4.8	1.9	17	17	★ 186097	QS-G1/4-6	10
		132039	QS-G1/4-6-100	100						
	8	7	21.9	4.8	1.9	17	15	★ 186099	QS-G1/4-8	10
		132040	QS-G1/4-8-50	50						
	10	8.5	28.9	4.8	1.9	17	21	★ 186101	QS-G1/4-10	10
		132041	QS-G1/4-10-50	50						
12	8.5	34.1	4.8	1.9	21	39	★ 186350	QS-G1/4-12	10	
	132042	QS-G1/4-12-20	20							
G3/8	8	7	21.7	5.8	2.4	19	22	★ 186100	QS-G3/8-8	10
		132043	QS-G3/8-8-50	50						
	10	9	25.4	5.8	2.4	19	22	★ 186102	QS-G3/8-10	10
		132044	QS-G3/8-10-50	50						
	12	11	31.5	5.8	2.4	21	33	★ 186103	QS-G3/8-12	10
		132045	QS-G3/8-12-20	20						
16	11	37.3	5.8	2.4	22	45	★ 186347	QS-G3/8-16	1	
	132046	QS-G1/2-12-20	20							
G1/2	12	11	28	6.8	2.4	24	39	★ 186104	QS-G1/2-12	1
		132046	QS-G1/2-12-20	20						
	16	13	35.3	6.8	2.4	24	51	★ 186105	QS-G1/2-16	1
132047		QS-G1/2-16-20	20							

1) 每包数量

技术参数

快插接头 QS G3/4-22

外螺纹, 带外六角

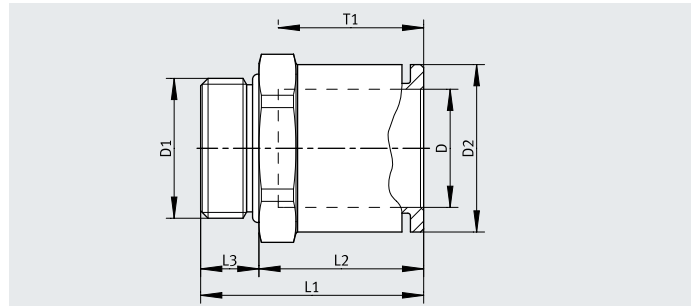
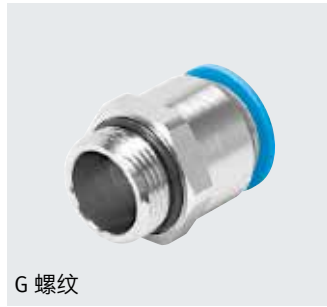

尺寸和订货数据		公称通径	尺寸 [mm]						重量/件	订货号	型号	PS ¹⁾
气接口	适用气管外径		D2 ∅	L1	L2	L3	T1 ∅	≈G 1				
D1	D	[mm]							[g]			
G 螺纹, 带密封圈												
G3/4	22	20	32	42.1	31.1	11	~27.5	32	90.5	8040613	QS-G3/4-22	1

1) 每包数量

技术参数

快插接头 QS-...-I
外螺纹, 带内六角

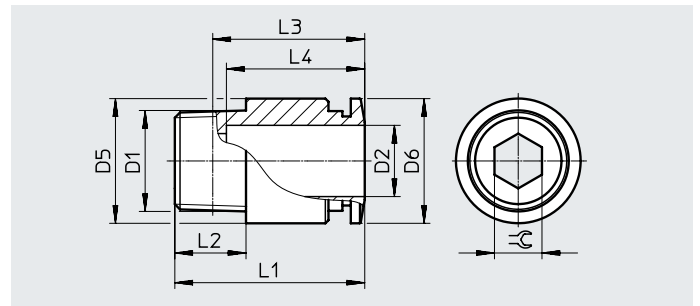

尺寸和订货数据		公称通径	尺寸 [mm]								重量/件	订货号	型号	PS ¹⁾
气接口	适用气管外径		D5 ∅	D6 ∅	L1	L2	L3	L4	L5	±C				
D1	D2	[mm]									[g]			
R 螺纹														
R1/8	4	2.6	9.7	9.9	20	8	16	14.9	-	2.5	6.6	★ 153012	QS-1/8-4-I	10
												133191	QS-1/8-4-I-100	100
	6	4.2	11.8	11.8	22.1	8	18.1	17	-	4	7.6	★ 153013	QS-1/8-6-I	10
												133186	QS-1/8-6-I-100	100
	8	5.3	13.7	13.8	25.9	8	21.9	18.2	-	5	8.8	★ 153015	QS-1/8-8-I	10
												133187	QS-1/8-8-I-50	50
	10	5.3	17.5	16.8	30.3	8	26.3	20.7	-	5	17	★ 190647	QS-1/8-10-I	10
R1/4	6	4.2	13.7	11.8	21.3	11	15.2	17	-	4	13	★ 153014	QS-1/4-6-I	10
												133193	QS-1/4-6-I-100	100
	8	6.3	13.7	13.8	25.1	11	19.1	18.2	-	6	13	★ 153016	QS-1/4-8-I	10
												133190	QS-1/4-8-I-50	50
	10	6.3	17.5	16.8	29.8	11	23.8	20.7	-	6	20	★ 153018	QS-1/4-10-I	10
												133188	QS-1/4-10-I-50	50
	12	6.3	20.8	19.8	35.9	11	29.9	23.3	-	6	29	★ 190649	QS-1/4-12-I	10
R3/8	8	6.3	16.8	13.8	22.2	12	15.9	18.2	-	6	19	★ 153017	QS-3/8-8-I	10
	10	6.3	17.5	16.8	29.3	12	23	20.7	-	6	26	★ 153019	QS-3/8-10-I	10
	12	8.4	20.8	19.8	31.9	12	25.6	23.3	-	8	31	★ 153020	QS-3/8-12-I	10
R1/2	10	6.3	20.8	16.8	30.3	15	22.1	20.7	-	6	45	★ 190648	QS-1/2-10-I	1
	12	8.4	20.8	19.8	33.9	15	25.7	23.3	-	8	45	★ 153021	QS-1/2-12-I	1

1) 每包数量

技术参数

快插接头 QS-...-I
外螺纹, 带内六角

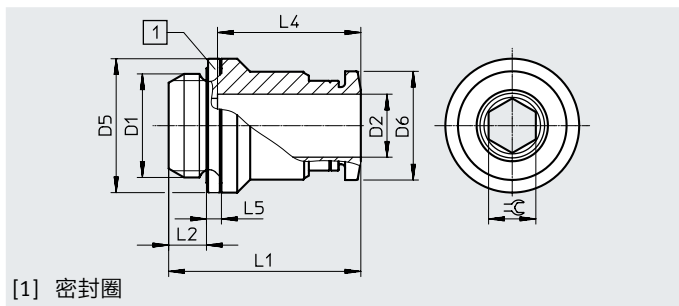

尺寸和订货数据		公称通径	尺寸 [mm]								重量/件	订货号	型号	PS ¹⁾
气接口	适用气管外径		D5 ∅	D6 ∅	L1	L2	L3	L4	L5	≈G				
D1	D2	[mm]									[g]			
G 螺纹, 带密封圈														
G1/8	4	2.6	13	9.9	19.5	4.2	-	14.9	1.9	2.5	7.7	★ 186106	QS-G1/8-4-I	10
												133008	QS-G1/8-4-I-100	100
	6	4.2	13	11.8	21.6	4.2	-	17	1.9	4	8.3	★ 186107	QS-G1/8-6-I	10
												133009	QS-G1/8-6-I-100	100
G1/8	8	5.3	13.7	13.8	25.8	4.2	-	18.2	1.9	5	12	★ 186109	QS-G1/8-8-I	10
												133010	QS-G1/8-8-I-100	100
	10	5.3	17	16.8	28.3	4.2	-	20.7	1.9	5	19	★ 132999	QS-G1/8-10-I	10
												133000	QS-G1/8-10-I-100	100
G1/4	6	4.2	17	11.8	20.2	4.8	-	17	1.9	4	13	★ 186108	QS-G1/4-6-I	10
	8	6.3	17	13.8	24.4	4.8	-	18.2	1.9	6	14	★ 186110	QS-G1/4-8-I	10
	10	7.3	17	16.8	28.9	4.8	-	20.7	1.9	7	20	★ 186112	QS-G1/4-10-I	10
G3/8	8	6.3	19	13.8	23.9	5.8	-	18.2	2.4	6	20	★ 186111	QS-G3/8-8-I	10
	10	7.3	19	16.8	26.4	5.8	-	20.7	2.4	7	22	★ 186113	QS-G3/8-10-I	10
	12	8.4	20.8	19.8	31.5	5.8	-	23.3	2.4	8	34	★ 186114	QS-G3/8-12-I	10
G1/2	12	8.4	24	19.8	28	6.8	-	23.3	2.4	8	33	★ 186115	QS-G1/2-12-I	1

1) 每包数量

技术参数

快插接头 QSF

内螺纹, 带外六角

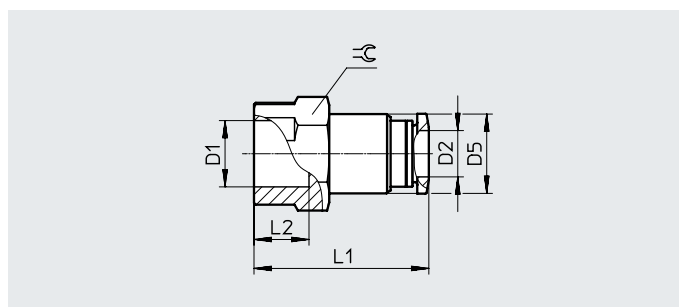

尺寸和订货数据										
气接口		公称通径	尺寸 [mm]				重量/件	订货号	型号	PS ¹⁾
内螺纹	适用气管外径		D5 ø	L1	L2	≅				
D1	D2	[mm]				[g]				
G 螺纹										
G1/8	4	3	9.7	23.9	7	14	13	★ 153022	QSF-1/8-4-B	10
								130709	QSF-1/8-4-B-100	100
	6	5	11.8	26	7	14	15	★ 153023	QSF-1/8-6-B	10
								130710	QSF-1/8-6-B-100	100
		7	13.7	27.2	7	14	16	★ 153025	QSF-1/8-8-B	10
							130711	QSF-1/8-8-B-50	50	
G1/4	4	3	9.7	26.9	9.5	17	21	★ 190650	QSF-1/4-4-B	10
								★ 153024	QSF-1/4-6-B	10
	6	5	11.8	29	9.5	17	23	★ 130712	QSF-1/4-6-B-100	100
								★ 153026	QSF-1/4-8-B	10
								130713	QSF-1/4-8-B-50	50
		7	13.7	30.2	9.5	17	24	★ 153028	QSF-1/4-10-B	10
						130714	QSF-1/4-10-B-50	50		
	9	17.5	32.7	9.5	17	30	★ 190651	QSF-1/4-12-B	10	
G3/8	6	5	11.8	30.5	11	21	30	★ 190652	QSF-3/8-6-B	10
								★ 153027	QSF-3/8-8-B	10
	8	7	13.7	31.7	11	21	32	★ 130715	QSF-3/8-8-B-50	50
								★ 153029	QSF-3/8-10-B	10
								130716	QSF-3/8-10-B-50	50
	9	17.5	34.2	11	21	38	★ 153030	QSF-3/8-12-B	10	
							130717	QSF-3/8-12-B-20	20	
G1/2	12	11	20.8	40.1	14	24	56	★ 190653	QSF-1/2-12-B	1
	16	15	25	41.6	14	25	69	★ 190654	QSF-1/2-16-B	1

1) 每包数量

技术参数

快插接头 QS

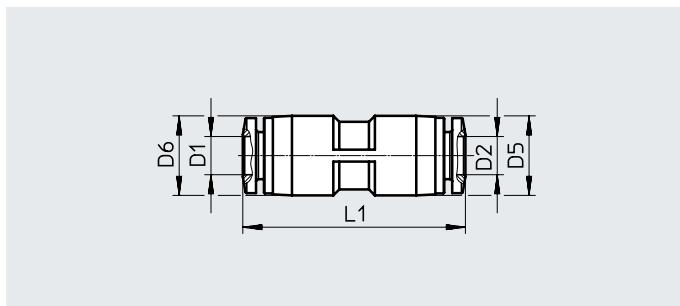

尺寸和订货数据									
气接口		公称通径	尺寸 [mm]			重量/件	订货号	型号	PS ¹⁾
适用气管外径	适用气管外径		D5 ∅	D6	L1				
D1	D2	[mm]				[g]			
4	4	2.8	10	-	30.8	4.7	★ 153031	QS-4	10
							130686	QS-4-100	100
6	6	4.3	12.5	-	34.9	6.5	★ 153032	QS-6	10
							130687	QS-6-100	100
8	8	7	14.5	-	37.8	9.4	★ 153033	QS-8	10
							130688	QS-8-50	50
10	10	9	17.5	-	41.4	16	★ 153034	QS-10	10
							130689	QS-10-50	50
12	12	11	21	-	47.8	22	★ 153035	QS-12	10
							130690	QS-12-20	20
16	16	13	25	-	50	26	153036	QS-16	1
							133195	QS-16-20	20
变径									
6	4	2.8	12.5	12.5	34.4	6.4	★ 153037	QS-6-4	10
							130691	QS-6-4-100	100
8	4	2.8	10.7	14.5	36.6	7.2	★ 130606	QS-8-4	10
		4.3	14.5	14.5	37.9	8.8	★ 153038	QS-8-6	10
	6	4.3	13	17.5	39.8	12	★ 130607	QS-10-6	10
10	8	6.5	17.5	17.5	41.1	14	★ 153039	QS-10-8	10
		6.2	14.5	21	44	16	★ 130608	QS-12-8	10
	10	9	21	21	47.6	21	★ 153040	QS-12-10	10
							130694	QS-12-10-20	20

1) 每包数量

技术参数

穿板式快插接头 QSS

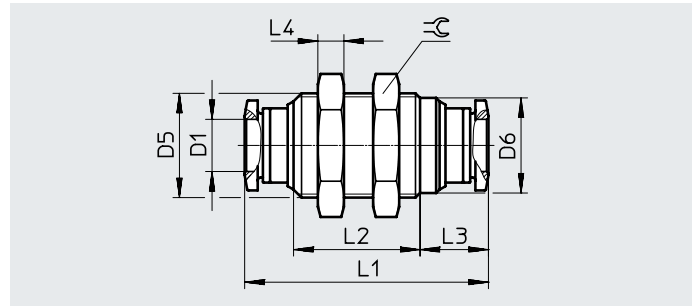
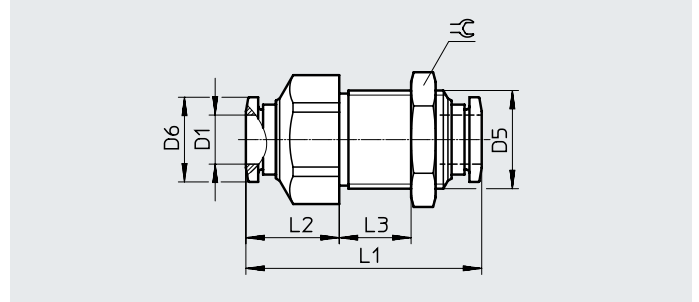
穿板式快插接头 QSS-...-F
带固定颈圈

尺寸和订货数据												
气接口	公称通径	尺寸 [mm]							重量/件	订货号	型号	PS ¹⁾
适用气管外径		D5	D6 ø	L1	L2	L3	L4	☉				
D1	[mm]								[g]			
4	3	M12x1	10.8	30.8	14.8	9.5	4	14	11	★ 153157	QSS-4	10
										130788	QSS-4-100	100
6	5	M14x1	12.5	34.9	19	9.5	4	17	16	★ 153158	QSS-6	10
										130789	QSS-6-100	100
8	7	M16x1	14.6	37.4	19.4	10.5	4	19	19	★ 153159	QSS-8	10
										130790	QSS-8-50	50
10	9	M20x1	18.5	42.4	21.6	11.9	5	24	35	★ 153160	QSS-10	10
										130791	QSS-10-50	50
12	11	M22x1	20.4	47.6	24.2	13.2	6	27	52	★ 153161	QSS-12	10
										130792	QSS-12-20	20
带固定颈圈												
4	2.6	M12x1	9.9	33	13	Max. 10	-	14	-	193950	QSS-4-F	10
6	4	M14x1	11.8	34.9	14.4	Max. 10	-	17	-	193951	QSS-6-F	10
8	5.5	M16x1	13.8	38.4	15.2	Max. 13	-	19	40	★ 130642	QSS-8-F	10
10	6.5	M20x1	16.8	47.1	20.3	Max. 15	-	24	86	★ 130643	QSS-10-F	10
12	7.5	M22x1	19.8	48.5	18.9	Max. 17.5	-	27	105	★ 130644	QSS-12-F	10

1) 每包数量

技术参数

穿板式快插接头 QSSF
通过内螺纹

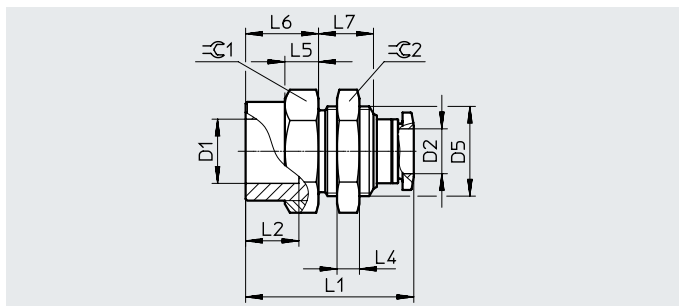

尺寸和订货数据															
气接口		公称通 径	尺寸 [mm]									重量/件 [g]	订货号	型号	PS ¹⁾
内螺纹	适用气管外径		D5 ∅	L1	L2	L4	L5	L6	L7	≈C1	≈C2				
D1	D2	[mm]													
G1/8	4	3	M12x1	24.2	7	4	5	9	9	14	14	17	153162	QSSF-1/8-4-B	10
	6	5	M14x1	26.4	7	4	6	10	10.2	17	17	25	153163	QSSF-1/8-6-B	10
	8	7	M16x1	27	7	4	6	10	9.8	19	19	30	153165	QSSF-1/8-8-B	10
G1/4	4	3	M12x1	27.5	9.5	4	6	12.3	9	17	14	24	190655	QSSF-1/4-4-B	10
	6	5	M14x1	28.7	9.5	4	6	12.3	10.2	17	17	27	153164	QSSF-1/4-6-B	10
	8	7	M16x1	30	9.5	4	6	13	9.8	19	19	34	153166	QSSF-1/4-8-B	10
	10	9	M20x1	32.7	9.5	5	7	13	11.1	24	24	57	153168	QSSF-1/4-10-B	10
G3/8	6	5	M14x1	30.9	11	4	6.5	14.5	10.2	21	17	36	190656	QSSF-3/8-6-B	10
	8	7	M16x1	31.5	11	4	6.5	14.5	9.8	21	19	38	153167	QSSF-3/8-8-B	10
	10	9	M20x1	34.2	11	5	7	14.5	11.1	24	24	57	153169	QSSF-3/8-10-B	10
	12	11	M22x1	36.8	11	6	7	14.5	12.4	24	27	66	153170	QSSF-3/8-12-B	10
G1/2	12	11	M22x1	40.1	14	6	7	17.8	12.4	24	27	70	153171	QSSF-1/2-12-B	1
	16	15	M27x1.5	42.6	14	9	8.5	17.3	15.4	29	32	116	190657	QSSF-1/2-16-B	1

1) 每包数量

技术参数

快插堵头 QSC

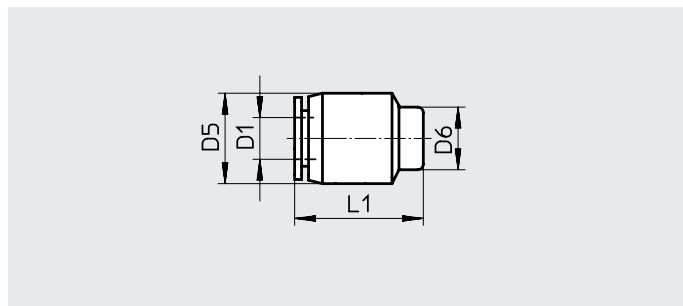

尺寸和订货数据							
气接口	尺寸 [mm]			重量/件	订货号	型号	PS ¹⁾
适用气管外径	D5 ∅	D6 ∅	L1				
D1				[g]			
4	10	7	16.5	2.5	★ 153262	QSC-4	10
					130704	QSC-4-100	100
6	13	9	18.5	3.5	★ 153263	QSC-6	10
					130705	QSC-6-100	100
8	15	11	20	5	★ 153264	QSC-8	10
					130706	QSC-8-50	50
10	18	13	22.5	8	★ 153265	QSC-10	10
					130707	QSC-10-50	50
12	21.5	16	23	11.5	★ 153266	QSC-12	10
					130708	QSC-12-20	20

1) 每包数量

技术参数

快插接头 QS-...H
带插入式轴套

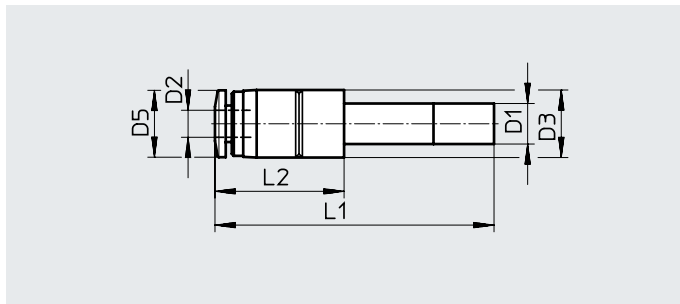

尺寸和订货数据										
气接口		公称通径	尺寸 [mm]				重量/件	订货号	型号	PS ¹⁾
插入式轴套	适用气管外径		D3 ∅	D5 ∅	L1	L2				
D1	D2	[mm]					[g]			
QS-6	4	2.5	10	9.9	37.7	15.2	2.9	★ 153041	QS-6H-4	10
								130695	QS-6H-4-100	100
QS-8	4	2.4	12.5	9.9	40.2	16.7	3.8	★ 130622	QS-8H-4	10
	6	3.8	12.5	11.8	40.8	17.3	4	★ 153042	QS-8H-6	10
QS-10	6	3.8	12.5	11.8	43.8	18.8	4.5	★ 130623	QS-10H-6	10
								★ 153043	QS-10H-8	10
								130697	QS-10H-8-50	50
QS-12	6	3.8	14.5	11.8	48.8	19.8	6	★ 132981	QS-12H-6	10
								★ 130624	QS-12H-8	10
								★ 153044	QS-12H-10	10
10	6.3	17.5	16.8	50	21	9.6	130698		QS-12H-10-20	20

1) 每包数量

技术参数

插入式轴套 QSH

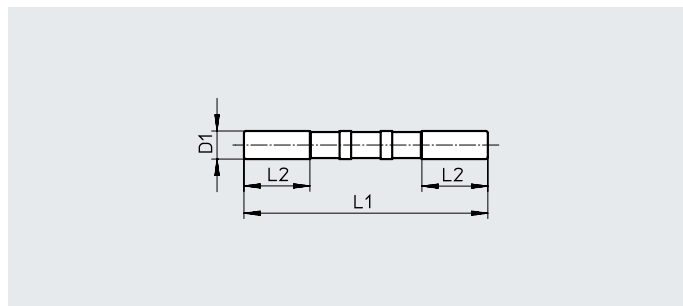

变径

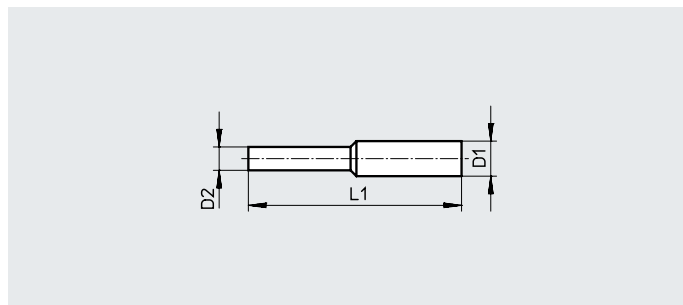

尺寸和订货数据								
气接口		公称通径 [mm]	尺寸 [mm]		重量/件 [g]	订货号	型号	PS ¹⁾
插入式轴套 D1	插入式轴套 D2		L1	L2				
QS-4	-	2.5	34.8	11.3	0.5	153251	QSH-4	10
						130723	QSH-4-100	100
QS-6	-	4	38.2	11.3	0.5	153252	QSH-6	10
						130724	QSH-6-100	100
QS-8	-	6	41.4	12.1	1	153253	QSH-8	10
						130725	QSH-8-50	50
QS-10	-	7.5	46.2	13	1.5	153254	QSH-10	10
						130726	QSH-10-50	50
QS-12	-	9	52.8	17.5	3	153255	QSH-12	10
						130727	QSH-12-20	20
QS-16	-	11	55.6	18	4	153256	QSH-16	1
变径								
QS-6	QS-4	2.3	36.7	-	0.5	153257	QSH-6-4	10
						130718	QSH-6-4-100	100
QS-8	QS-4	2.3	41.1	-	0.9	130625	QSH-8-4	10
						153258	QSH-8-6	10
	QS-6	3.8	40.5	-	0.9	130719	QSH-8-6-50	50
QS-10	QS-6	3.8	43.7	-	1.4	130626	QSH-10-6	10
						153259	QSH-10-8	10
	QS-8	4.9	44	-	1.3	130720	QSH-10-8-50	50
QS-12	QS-8	4.9	47.5	-	2.1	130627	QSH-12-8	10
						153260	QSH-12-10	10
	QS-10	7.1	49.6	-	2.2	130721	QSH-12-10-20	20
QS-16	QS-12	7.8	54.4	-	4.2	153261	QSH-16-12	1
						130722	QSH-16-12-20	20

1) 每包数量

技术参数

堵头 QSC-...H

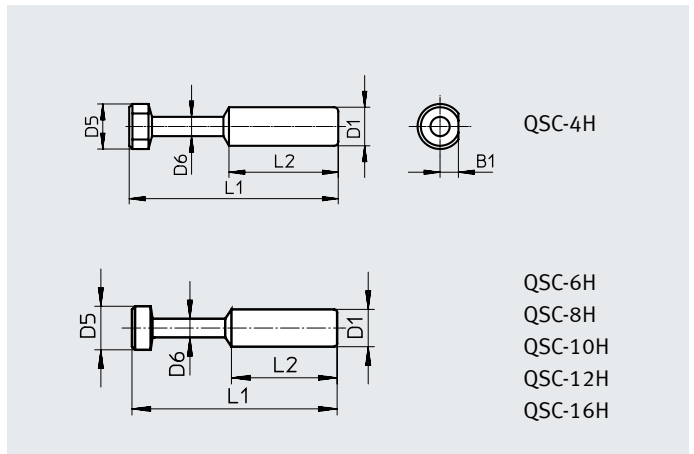

尺寸和订货数据									
气接口	尺寸 [mm]					重量/件	订货号	型号	PS ¹⁾
插入式轴套	B1	D5 ∅	D6 ∅	L1	L2				
D1						[g]			
QS-4	2.1	5	3	28	15	0.5	★ 153267 130699	QSC-4H QSC-4H-100	10 100
QS-6	-	7	3	33	17	0.5	★ 153268 130700	QSC-6H QSC-6H-100	10 100
QS-8	-	9	4	37	18	1	★ 153269 130701	QSC-8H QSC-8H-50	10 50
QS-10	-	11	5	42	20.5	2	★ 153270 130702	QSC-10H QSC-10H-50	10 50
QS-12	-	13	6	44	23	2.5	★ 153271 130703	QSC-12H QSC-12H-20	10 20
QS-16	-	17	8	46	24	4	153272	QSC-16H	1

1) 每包数量

技术参数

L 型快插接头 QSL

外螺纹, 带外六角, 可旋转

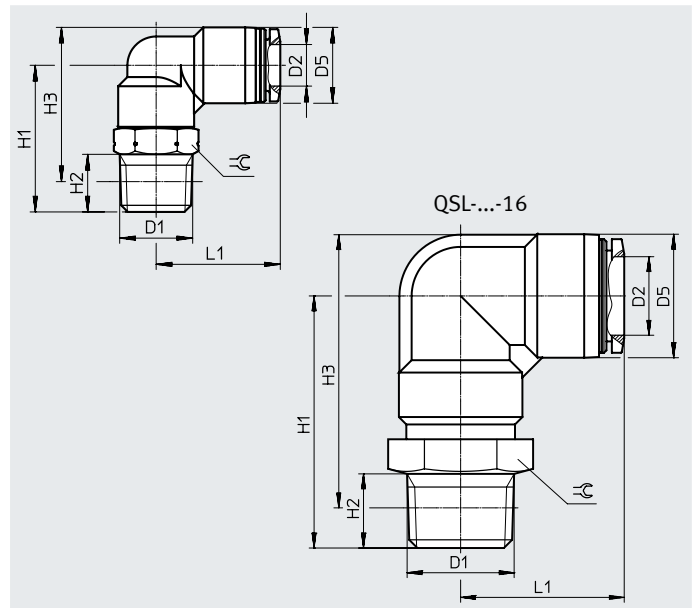

尺寸和订货数据												
气接口		公称通径 [mm]	尺寸 [mm]						重量/件 [g]	订货号	型号	PS ¹⁾
外螺纹 D1	适用气管外径 D2		D5 ∅	H1	H2	H3	L1	⊕				
R 螺纹												
R1/8	4	2.8	10	22	8	23	18.7	10	10	★ 153045	QSL-1/8-4	10
										★ 130728	QSL-1/8-4-100	100
	6	4.2	12.5	22.5	8	24.8	20.3	10	11	★ 153046	QSL-1/8-6	10
										★ 130729	QSL-1/8-6-100	100
	8	6	14.5	24	8	27.3	22.7	12	14	★ 153048	QSL-1/8-8	10
										★ 130730	QSL-1/8-8-50	50
	10	6	17.5	25	8	29.8	25.5	12	18	★ 190658	QSL-1/8-10	10
R1/4	4	2.8	10	29	11	28	20.7	14	18	★ 190659	QSL-1/4-4	10
	6	4.3	12.5	28	11	28.2	21.8	14	19	★ 153047	QSL-1/4-6	10
										★ 130731	QSL-1/4-6-100	100
	8	6.7	14.5	28	11	29.2	23.7	14	20	★ 153049	QSL-1/4-8	10
										★ 130732	QSL-1/4-8-50	50
	10	8	17.5	28.5	11	31.2	26	14	23	★ 153051	QSL-1/4-10	10
										★ 130733	QSL-1/4-10-50	50
	12	8	21	29.8	11	34.2	29	14	27	★ 164981	QSL-1/4-12	10
										★ 130734	QSL-1/4-12-20	20
R3/8	6	4.3	12.5	31.5	12	31.4	23.8	17	30	★ 190660	QSL-3/8-6	10
	8	6.7	14.5	31	12	31.9	24.7	17	31	★ 153050	QSL-3/8-8	10
										★ 130735	QSL-3/8-8-50	50
	10	8.3	17.5	32	12	34.4	27	17	34	★ 153052	QSL-3/8-10	10
										★ 130736	QSL-3/8-10-20	20
	12	10	21	32.5	12	36.7	29.7	17	38	★ 153053	QSL-3/8-12	10
										★ 130737	QSL-3/8-12-20	20
	16	11	25	47	11	53.2	33.1	22	74	★ 164958	QSL-3/8-16	1
R1/2	10	8.3	17.5	36	15	36.6	27.5	21	57	★ 190661	QSL-1/2-10	1
										★ 133192	QSL-1/2-10-50	50
	12	10.3	21	36.5	15	38.8	30.7	21	61	★ 153054	QSL-1/2-12	1
										★ 130738	QSL-1/2-12-20	20
	16	13	25	51	15	55.3	33.1	22	79	★ 153055	QSL-1/2-16	1
										★ 130739	QSL-1/2-16-20	20

1) 每包数量

技术参数

L 型快插接头 QSL

外螺纹, 带外六角, 可旋转

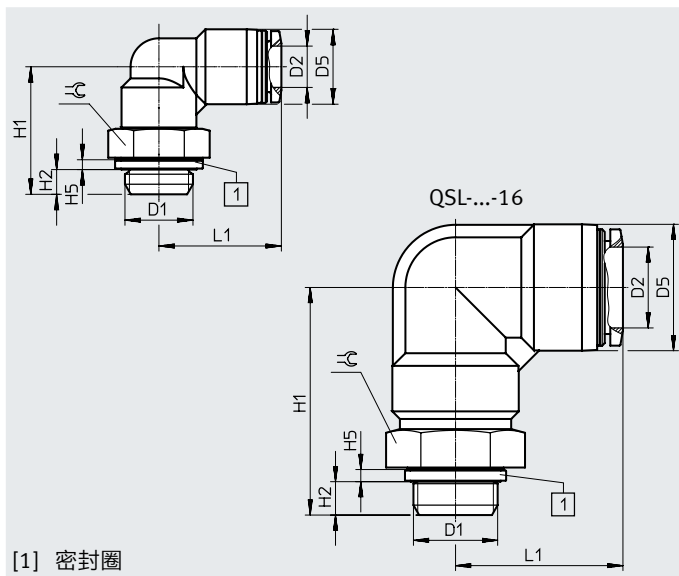

尺寸和订货数据												
气接口		公称通径 [mm]	尺寸 [mm]						重量/件 [g]	订货号	型号	PS ¹⁾
外螺纹 D1	适用气管外径 D2		D5 ∅	H1	H2	H5	L1	≈				
G 螺纹, 带密封圈												
G1/8	4	2.8	10	21.1	4.2	1.9	18.7	13	13	★ 186116	QSL-G1/8-4	10
	6	4.2	12.5	21.6	4.2	1.9	20.3	13	14	132048	QSL-G1/8-4-100	100
										★ 186117	QSL-G1/8-6	10
	8	6	14.5	22.1	4.2	1.9	22.7	13	15	132049	QSL-G1/8-6-100	100
										★ 186119	QSL-G1/8-8	10
										132050	QSL-G1/8-8-50	50
G1/4	6	4.3	12.5	24.7	4.8	1.9	21.8	17	21	★ 186118	QSL-G1/4-6	10
	8	6.7	14.5	24.7	4.8	1.9	23.7	17	23	132051	QSL-G1/4-6-100	100
										★ 186120	QSL-G1/4-8	10
	10	8	17.5	25.2	4.8	1.9	26	17	26	132052	QSL-G1/4-8-50	50
										★ 186122	QSL-G1/4-10	10
	12	8	21	26.5	4.8	1.9	29	17	29	132053	QSL-G1/4-10-50	50
★ 186351										QSL-G1/4-12	10	
										132054	QSL-G1/4-12-20	20
G3/8	8	6.7	14.5	27.2	5.8	2.4	24.7	19	30	★ 186121	QSL-G3/8-8	10
	10	8.3	17.5	28.2	5.8	2.4	27	19	33	132055	QSL-G3/8-8-50	50
										★ 186123	QSL-G3/8-10	10
	12	10	21	28.7	5.8	2.4	29.7	19	37	132056	QSL-G3/8-10-20	20
										★ 186124	QSL-G3/8-12	10
										132057	QSL-G3/8-12-20	20
G1/2	12	10.3	21	32.2	6.8	2.4	30.7	24	67	★ 186348	QSL-G3/8-16	1
	16	13	25	45.2	6.8	2.4	33.1	24	75	★ 186125	QSL-G1/2-12	1
										132058	QSL-G1/2-12-20	20
										★ 186126	QSL-G1/2-16	1
										132059	QSL-G1/2-16-20	20

1) 每包数量

技术参数

L 型快插接头, 长 QSL

外螺纹, 带外六角, 可旋转

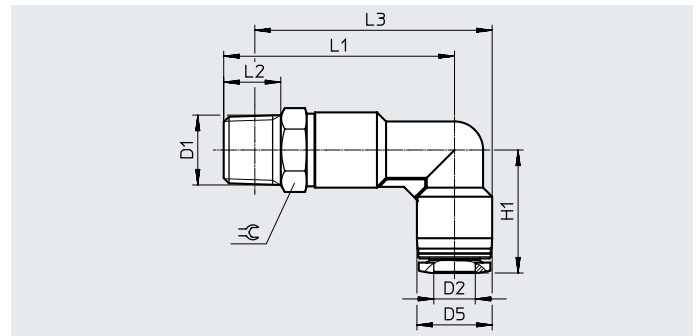

尺寸和订货数据												
气接口		公称通径	尺寸 [mm]						重量/件	订货号	型号	PS ¹⁾
外螺纹	适用气管外径		D5 ∅	H1	L1	L2	L3	≈C				
D1	D2	[mm]							[g]			
R 螺纹												
R1/8	4	2.8	10	18.7	34	8	35	10	11	★ 153076	QSL-1/8-4	10
	6	4.3	12.5	20.3	37	8	39.3	10	13	★ 153077	QSL-1/8-6	10
	8	6	14.5	22.7	40.5	8	43.8	12	16	★ 153079	QSL-1/8-8	10
R1/4	4	2.8	10	20.7	41	11	40	14	19	★ 190662	QSL-1/4-4	10
	6	4.3	12.5	21.8	42.5	11	42.7	14	20	★ 153078	QSL-1/4-6	10
	8	6.7	14.5	23.7	44.5	11	45.7	14	22	★ 153080	QSL-1/4-8	10
	10	8	17.5	26	48	11	50.7	14	26	★ 153082	QSL-1/4-10	10
R3/8	6	4.3	12.5	23.8	46	12	45.9	17	33	★ 190663	QSL-3/8-6	10
	8	6.7	14.5	24.7	47.5	12	48.4	17	35	★ 153081	QSL-3/8-8	10
	10	8.3	17.5	27	51.5	12	53.9	17	38	★ 153083	QSL-3/8-10	10
	12	10	21	29.7	55.5	12	59.7	17	42	★ 153084	QSL-3/8-12	10
R1/2	10	8.3	17.5	27	55.5	15	56.1	21	63	★ 190664	QSL-1/2-10	1
	12	10.3	21	29.7	59.5	15	61.8	21	68	★ 153085	QSL-1/2-12	1

1) 每包数量

技术参数

L 型快插接头, 长 QSL

外螺纹, 带外六角, 可旋转

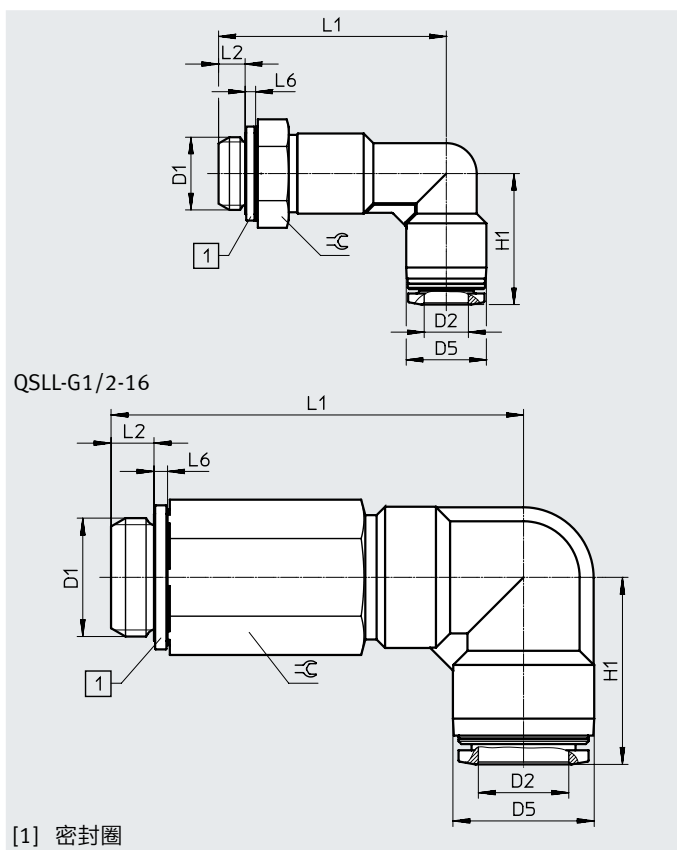
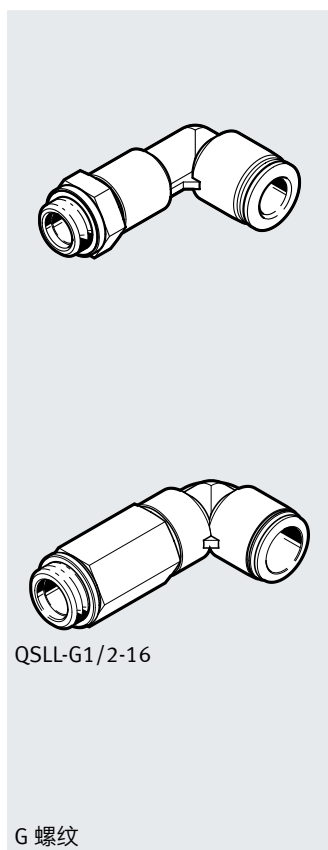

尺寸和订货数据

气接口		公称通径	尺寸 [mm]							重量/件	订货号	型号	PS ¹⁾
外螺纹	适用气管外径		D5 ∅	H1	L1	L2	L6	≈					
D1	D2	[mm]							[g]				
G 螺纹, 带密封圈													
G1/8	4	2.8	10	18.7	33.1	4.2	1.9	13	14	186127	QSL-G1/8-4	10	
										133015	QSL-G1/8-4-100	100	
	6	4.3	12.5	20.3	36.1	4.2	1.9	13	15	186128	QSL-G1/8-6	10	
										133016	QSL-G1/8-6-100	100	
	8	6	14.5	22.7	38.6	4.2	1.9	13	17	186130	QSL-G1/8-8	10	
										133017	QSL-G1/8-8-100	100	
G1/4	6	4.3	12.5	21.8	39.2	4.8	1.9	17	25	186129	QSL-G1/4-6	10	
	8	6.7	14.5	23.7	41.2	4.8	1.9	17	27	186131	QSL-G1/4-8	10	
	10	8	17.5	26	44.7	4.8	1.9	17	31	186133	QSL-G1/4-10	10	
	12	8	21	29	49.5	4.8	1.9	17	35	132596	QSL-G1/4-12	1	
G3/8	8	6.7	14.5	24.7	43.7	5.8	2.4	19	34	186132	QSL-G3/8-8	10	
	10	8.3	17.5	27	47.7	5.8	2.4	19	37	186134	QSL-G3/8-10	10	
	12	10	21	29.7	51.7	5.8	2.4	19	41	186135	QSL-G3/8-12	10	
G1/2	12	10.3	21	29.7	55.2	6.8	2.4	24	75	186136	QSL-G1/2-12	1	
	16	13	25	33.1	72.2	6.8	2.4	24	158	190665	QSL-G1/2-16	1	

1) 每包数量

技术参数

L 型快插接头 QSLF

内螺纹, 带外六角, 可旋转

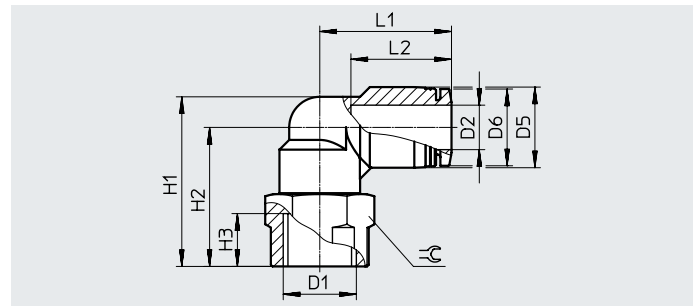

尺寸和订货数据		公称通径	尺寸 [mm]								重量/件	订货号	型号	PS ¹⁾
气接口	适用气管外径		D5 ∅	D6 ∅	H1	H2	H3	L1	L2	≅				
D1	D2	[mm]									[g]			
G 螺纹														
G1/8	4	2.8	10	9.9	25	20	7	18.7	14.9	14	14	★ 153273	QSLF-1/8-4-B	10
	6	4.2	12.5	11.8	26.8	20.5	7	20.3	17	14	15	★ 153274	QSLF-1/8-6-B	10
	8	6	14.5	13.8	28.3	21	7	22.7	18.1	14	16	★ 153276	QSLF-1/8-8-B	10
G1/4	6	4.3	12.5	11.8	31.3	25	9.5	21.8	17	17	22	★ 153275	QSLF-1/4-6-B	10
	8	6.7	14.5	13.8	32.3	25	9.5	23.7	18.1	17	24	★ 153277	QSLF-1/4-8-B	10
	10	8	17.5	16.8	34.3	25.5	9.5	26	20.2	17	27	★ 153279	QSLF-1/4-10-B	10
G3/8	8	6.7	14.5	13.8	34.8	27.5	11	24.7	18.1	21	33	★ 153278	QSLF-3/8-8-B	10
	10	8.3	17.5	16.8	37.3	28.5	11	27	20.2	21	36	★ 153280	QSLF-3/8-10-B	10

1) 每包数量

技术参数

L 型快插接头 QSLV...-I

外螺纹, 带内六角, 可旋转



R 螺纹

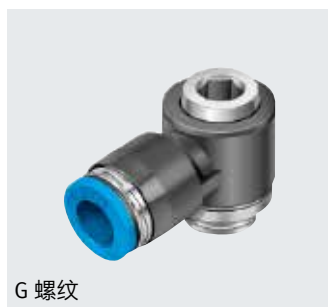
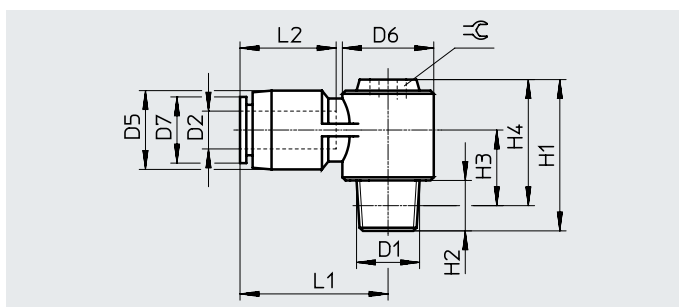

G 螺纹

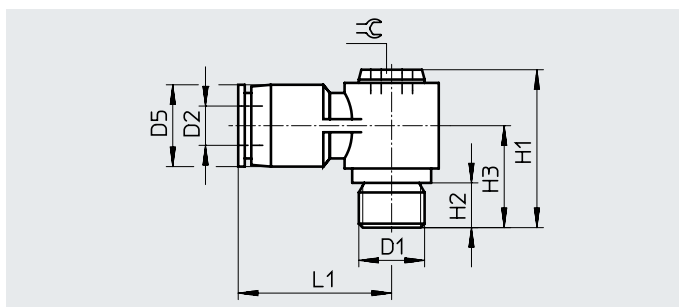

尺寸和订货数据

气接口		公称 口径	尺寸 [mm]										重量/件 [g]	订货号	型号	PS ¹⁾
外螺纹	适用气管外径		D5 ∅	D6 ∅	D7 ∅	H1	H2	H3	H4	L1	L2	⌀				
D1	D2	[mm]														
R 螺纹																
R1/8	6	3	13	14.3	11.8	24	8	11.5	20	23.7	17	5	15	153097	QSLV-1/8-6-I	10
	8	4.2	14	17.9	13.8	27	8	12	23	26.7	18.1	8	22	153099	QSLV-1/8-8-I	10
R1/4	6	3.1	13	14.3	11.8	27	11	12.5	21	23.7	17	5	22	153098	QSLV-1/4-6-I	10
	8	4	14	17.9	13.8	30	11	13	24	26.7	18.1	8	28	153100	QSLV-1/4-8-I	10
	10	5.4	18	21.3	16.8	34	11	15	28	30.7	20.7	10	40	153102	QSLV-1/4-10-I	10
R3/8	8	4.2	14	17.9	13.8	31	12	13.7	24.7	26.7	18.1	8	37	153101	QSLV-3/8-8-I	10
	10	5.4	18	21.3	16.8	35	12	15.7	28.7	30.7	20.7	10	49	153103	QSLV-3/8-10-I	10
	12	6.9	21	26.3	19.8	39	12	17.7	32.7	36.4	23.4	12	68	153104	QSLV-3/8-12-I	10
R1/2	12	6.4	21	26.3	19.8	42	15	18.8	33.8	36.4	23.4	12	85	153105	QSLV-1/2-12-I	1
G 螺纹																
G1/8	6	3	13	-	-	23	5.1	14.5	-	23.7	-	5	15	186148	QSLV-G1/8-6-I	10
	8	4.2	14	-	-	26	5.1	15	-	26.7	-	8	22	186150	QSLV-G1/8-8-I	10
G1/4	6	3.1	13	-	-	23.5	5.6	15	-	23.7	-	5	19	186149	QSLV-G1/4-6-I	10
	8	4	14	-	-	26.5	5.6	15.5	-	26.7	-	8	25	186151	QSLV-G1/4-8-I	10
	10	5.4	18	-	-	30.5	5.6	17.5	-	30.7	-	10	38	186153	QSLV-G1/4-10-I	10
G3/8	8	4.2	14	-	-	28	6.6	17	-	26.7	-	8	33	186152	QSLV-G3/8-8-I	10
	10	5.4	18	-	-	32	6.6	19	-	30.7	-	10	45	186154	QSLV-G3/8-10-I	10
	12	6.9	21	-	-	36	6.6	21	-	36.4	-	12	65	186155	QSLV-G3/8-12-I	10
G1/2	12	6.4	21	-	-	37	7.6	22	-	36.4	-	12	75	186156	QSLV-G1/2-12-I	1

1) 每包数量

技术参数

L 型快插接头 QSLV

外螺纹, 带外六角, 可旋转

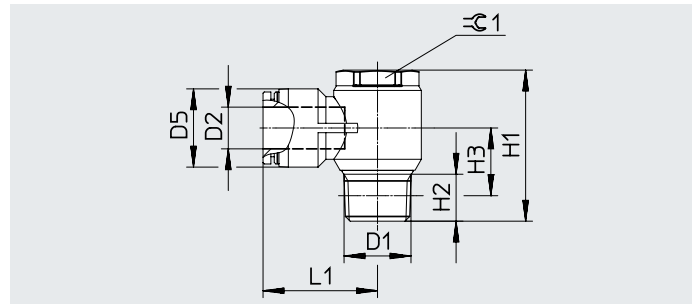
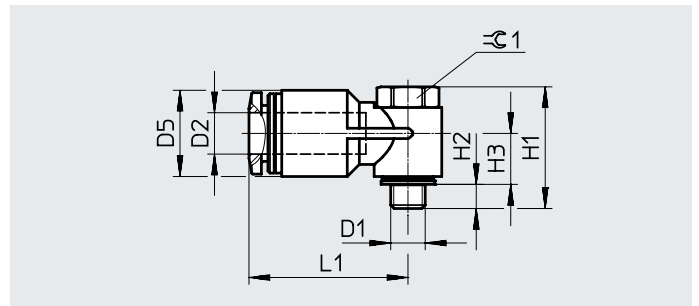

尺寸和订货数据												
气接口		公称通径	尺寸 [mm]						重量/件	订货号	型号	PS ¹⁾
外螺纹	适用气管外径		D5 ø	H1	H2	H3	L1	±0.1				
D1	D2	[mm]						[g]				
公制螺纹, 带密封圈												
M5	6	1.8	12.5	17.2	3	7.4	23.1	8	8.3	★ 190666	QSLV-M5-6	10
R 螺纹												
R1/8	4	2.8	10	27	8	12	22.2	14	21	★ 153086	QSLV-1/8-4	10
										130749	QSLV-1/8-4-100	100
	6	4.6	12.5	27	8	12	24.2	14	22	★ 153087	QSLV-1/8-6	10
										130750	QSLV-1/8-6-100	100
R1/4	8	5.5	14.5	27	8	12.3	26.2	14	23	★ 153089	QSLV-1/8-8	10
										130751	QSLV-1/8-8-50	50
	6	4.3	12.5	31.5	11	13.5	26.8	17	36	★ 153088	QSLV-1/4-6	10
										130752	QSLV-1/4-6-100	100
R1/4	8	6	14.5	31.5	11	13.5	28.2	17	38	★ 153090	QSLV-1/4-8	10
										130753	QSLV-1/4-8-50	50
	10	7.1	17.5	31.5	11	15	30.5	17	41	★ 153092	QSLV-1/4-10	10
										130754	QSLV-1/4-10-50	50
R3/8	8	6	14.5	36	12	15.7	30.2	21	60	★ 153091	QSLV-3/8-8	10
	10	8	18	36	12	15.7	32.5	21	63	★ 153093	QSLV-3/8-10	10
	12	9.3	21	36	12	17.2	35.2	21	66	★ 153094	QSLV-3/8-12	10
R1/2	12	10	21	40.2	13	16.5	38.2	24	97	★ 153095	QSLV-1/2-12	1
	16	13	25	48.3	15	21.6	36.6	24	105	153096	QSLV-1/2-16	1

1) 每包数量

技术参数

L 型快插接头 QSLV

外螺纹, 带外六角, 可旋转



G 螺纹

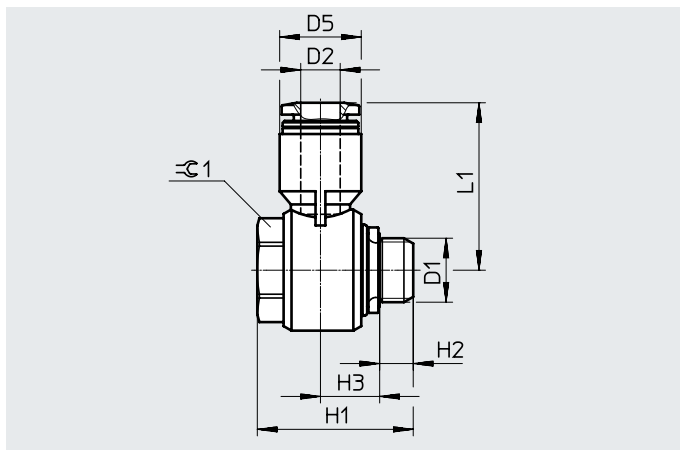

尺寸和订货数据												
气接口		公称通径	尺寸 [mm]						重量/件	订货号	型号	PS ¹⁾
外螺纹	适用气管外径		D5 ∅	H1	H2	H3	L1	±0.1				
D1	D2	[mm]						[g]				
G 螺纹, 带密封圈												
G1/8	4	3	10	23.7	5.1	8.7	23.4	14	22	★ 186137	QSLV-G1/8-4	10
		132060	QSLV-G1/8-4-100	100								
	6	4	12.4	23.7	5.1	9	25.5	14	23	★ 186138	QSLV-G1/8-6	10
		132061	QSLV-G1/8-6-100	100								
	8	5.6	14.4	23.7	5.1	10	28.4	14	25	★ 186140	QSLV-G1/8-8	10
		132062	QSLV-G1/8-8-50	50								
G1/4	6	5	14.5	28.6	5.6	10.4	29	19	44	★ 186139	QSLV-G1/4-6	10
		132063	QSLV-G1/4-6-100	100								
	8	6	14.5	28.6	5.6	10.4	28.9	19	45	★ 186141	QSLV-G1/4-8	10
		132064	QSLV-G1/4-8-50	50								
	10	7	17.6	28.6	5.6	11.7	31.2	19	48	★ 186143	QSLV-G1/4-10	10
		132065	QSLV-G1/4-10-50	50								
G3/8	8	6	14.4	33.1	6.6	12.6	31	24	71	★ 186142	QSLV-G3/8-8	10
	10	8	17.6	33.1	6.6	12.6	33.6	24	74	★ 186144	QSLV-G3/8-10	10
	12	8.7	21	33.1	6.6	14.3	36.4	24	77	★ 186145	QSLV-G3/8-12	10
G1/2	12	8.7	21	34	7.6	14.3	37.9	27	99	★ 186146	QSLV-G1/2-12	1
	16	13	25	43.1	7.6	17.2	38.1	27	115	★ 186147	QSLV-G1/2-16	1

1) 每包数量

技术参数

L 型快插接头 QSL

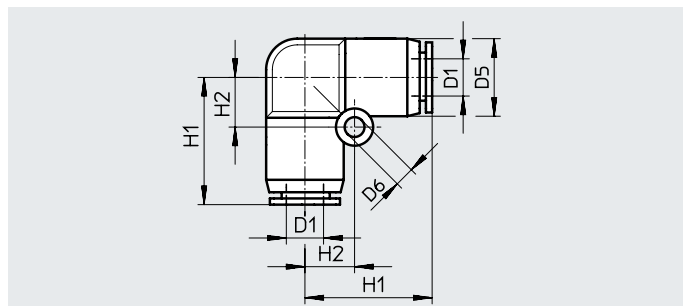

尺寸和订货数据									
气接口	公称通 径	尺寸 [mm]				重量/件	订货号	型号	PS ¹⁾
适用气管外径		D5 ∅	D6 ∅	H1	H2				
D1	[mm]					[g]			
4	2.8	10	3.2	16.9	6.5	5.1	★ 153070	QSL-4	10
							130740	QSL-4-100	100
6	5	12.5	3.2	20.1	8	7.3	★ 153071	QSL-6	10
							130741	QSL-6-100	100
8	7.2	15	4.2	22.4	10	11	★ 153072	QSL-8	10
							130742	QSL-8-50	50
10	8.3	17.5	4.2	26.2	12	17	★ 153073	QSL-10	10
							130743	QSL-10-50	50
12	10	21	4.2	29.4	14	25	★ 153074	QSL-12	10
							130744	QSL-12-20	20
16	13	25	4.2	33.1	12	31	153075	QSL-16	1
							133194	QSL-16-20	20

1) 每包数量

技术参数

L 型快插接头 QSL-...H 带插入式轴套

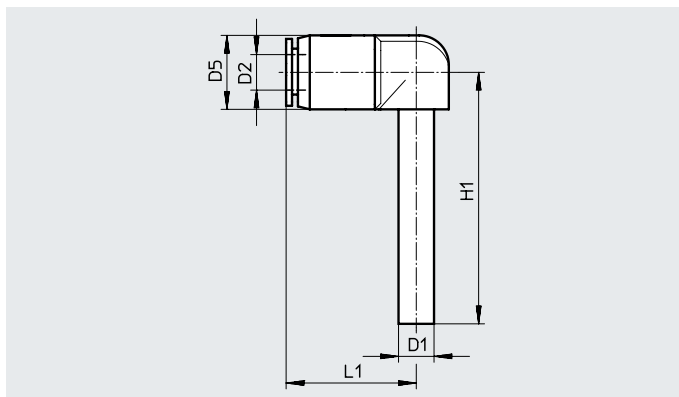
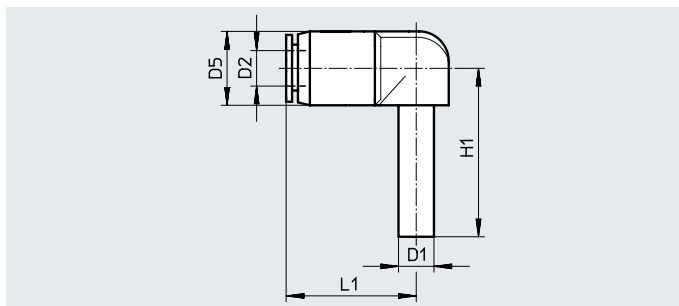

尺寸和订货数据									
气接口		公称通径 [mm]	尺寸 [mm]			重量/件 [g]	订货号	型号	PS ¹⁾
插入式轴套 D1	适用气管外径 D2		D5 ∅	H1	L1				
QS-4	4	2	10	25	16.8	2.7	★ 153056	QSL-4H	10
							130745	QSL-4H-100	100
QS-6	6	3.2	12.5	28.5	19.8	3.9	★ 153057	QSL-6H	10
							130746	QSL-6H-100	100
QS-8	8	4.7	14.5	30.7	21.8	5.7	★ 153058	QSL-8H	10
							130747	QSL-8H-50	50
QS-10	10	5.7	17.5	33.7	24.9	9.6	★ 153059	QSL-10H	10
							130748	QSL-10H-50	50
QS-12	12	6.8	21	39	28.9	15	★ 153060	QSL-12H	10
变径									
QS-6	4	2.4	12.5	28.5	17.7	3.6	★ 153061	QSL-6H-4	10
QS-8	6	3.5	14.5	30.7	21.9	5.2	★ 153062	QSL-8H-6	10
QS-10	8	4.9	17.5	33.7	24.6	8	★ 153063	QSL-10H-8	10
QS-12	10	6.1	21	39	28.7	14	★ 153064	QSL-12H-10	10
长 插入式轴套									
QS-4	4	2	10	36	16.8	2.8	★ 153065	QSL-4HL	10
QS-6	6	3.1	12.5	42	19.8	4.2	★ 153066	QSL-6HL	10
QS-8	8	4.5	14.5	46.7	21.8	6.2	★ 153067	QSL-8HL	10
QS-10	10	5.6	17.5	51.7	24.9	11	★ 153068	QSL-10HL	10
QS-12	12	6.7	21	59.5	28.95	16	★ 153069	QSL-12HL	10

1) 每包数量

技术参数

T 型快插接头 QST

外螺纹, 带外六角, 可旋转

气源管线数量: 1

输出口数量: 2

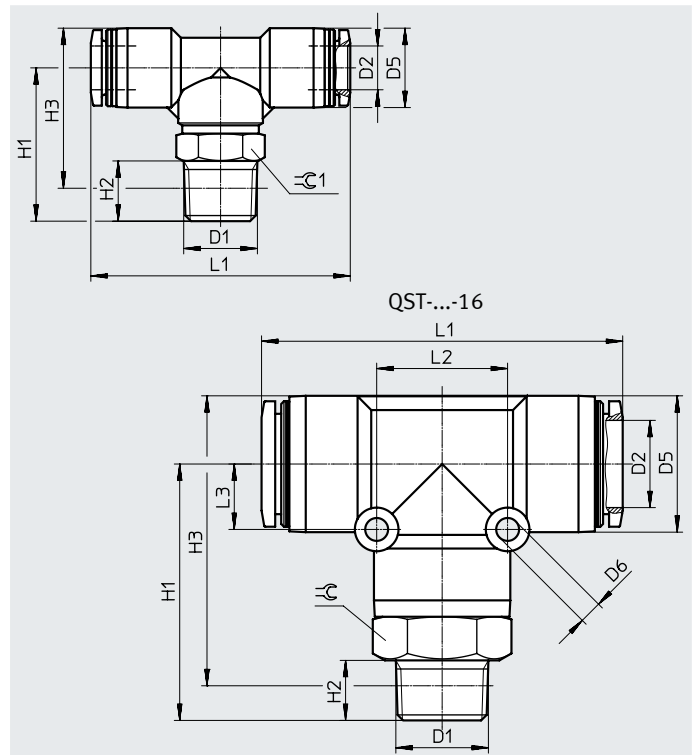

尺寸和订货数据		公称通径	尺寸 [mm]									重量/件	订货号	型号	PS ¹⁾
气接口	适用气管外径		D5 ∅	D6 ∅	H1	H2	H3	L1	L2	L3	≈				
外螺纹	D1	D2	[mm]									[g]			
R 螺纹															
R1/8	4	2.8	10	-	22	8	23	37.4	-	-	10	13	★ 153106	QST-1/8-4	10
													130793	QST-1/8-4-100	100
	6	4.2	12.5	-	22.5	8	24.8	40.5	-	-	10	14	★ 153107	QST-1/8-6	10
													130794	QST-1/8-6-100	100
	8	6	14.5	-	24	8	27.3	45.4	-	-	12	19	★ 153109	QST-1/8-8	10
													130795	QST-1/8-8-50	50
	10	6	17.5	-	25	8	29.8	51	-	-	12	25	★ 190667	QST-1/8-10	10
R1/4	4	2.8	10	-	29	11	28	41.4	-	-	14	20	★ 190668	QST-1/4-4	10
	6	4.3	12.5	-	28	11	28.2	43.5	-	-	14	22	★ 153108	QST-1/4-6	10
													130796	QST-1/4-6-100	100
	8	6.7	14.5	-	28	11	29.2	47.4	-	-	14	25	★ 153110	QST-1/4-8	10
													130797	QST-1/4-8-50	50
	10	8	17.5	-	28.5	11	31.2	52	-	-	14	31	★ 153112	QST-1/4-10	10
													130798	QST-1/4-10-50	50
	12	8	21	-	29.8	11	34.2	57.9	-	-	14	38	★ 190669	QST-1/4-12	10
R3/8	6	4.3	12.5	-	31.5	12	31.4	47.5	-	-	17	33	★ 190670	QST-3/8-6	10
	8	6.7	14.5	-	31	12	31.9	49.4	-	-	17	35	★ 153111	QST-3/8-8	10
													130799	QST-3/8-8-50	50
	10	8.3	17.5	-	32	12	34.4	54	-	-	17	42	★ 153113	QST-3/8-10	10
													130800	QST-3/8-10-20	20
	12	10	21	-	32.5	12	36.7	59.4	-	-	17	48	★ 153114	QST-3/8-12	10
													130801	QST-3/8-12-20	20
	16	11	25	4.2	47	11	53.2	66.2	24	12	22	89	164959	QST-3/8-16	1
R1/2	10	8.3	17.5	-	36	15	36.6	55	-	-	21	65	★ 190672	QST-1/2-10	1
	12	10.3	21	-	36.5	15	38.8	61.4	-	-	21	72	★ 153115	QST-1/2-12	1
	16	13	25	4.2	51	15	55.3	66.2	24	12	22	93	153116	QST-1/2-16	1

1) 每包数量

技术参数

T 型快插接头 QST

外螺纹, 带外六角, 可旋转

气源管线数量: 1

输出口数量: 2

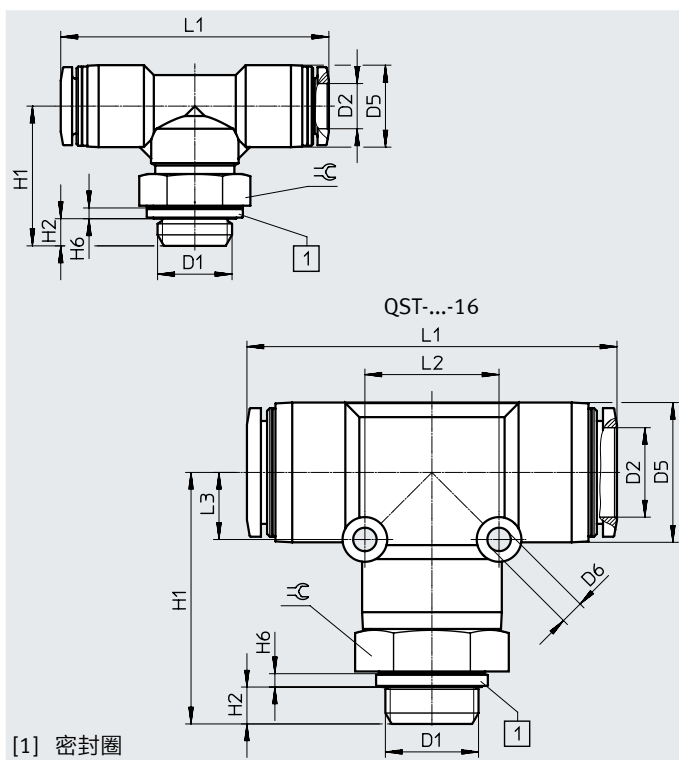

尺寸和订货数据		公称通径	尺寸 [mm]										重量/件	订货号	型号	PS ¹⁾
气接口	适用气管外径		D5 ∅	D6 ∅	H1	H2	H6	L1	L2	L3	≈					
D1	D2	[mm]											[g]			
G 螺纹, 带密封圈																
G1/8	4	2.8	10	-	21.1	4.2	1.9	37.4	-	-	13	15	186157	QST-G1/8-4	10	
													132066	QST-G1/8-4-100	100	
	6	4.2	12.5	-	21.6	4.2	1.9	40.5	-	-	13	17	186158	QST-G1/8-6	10	
													132067	QST-G1/8-6-100	100	
	8	6	14.5	-	22.1	4.2	1.9	45.4	-	-	13	19	186160	QST-G1/8-8	10	
													132068	QST-G1/8-8-50	50	
G1/4	6	4.3	12.5	-	24.7	4.8	1.9	43.5	-	-	17	24	186159	QST-G1/4-6	10	
													132069	QST-G1/4-6-100	100	
	8	6.7	14.5	-	24.7	4.8	1.9	47.4	-	-	17	27	186161	QST-G1/4-8	10	
													132070	QST-G1/4-8-50	50	
	10	8	17.5	-	25.2	4.8	1.9	52	-	-	17	33	186163	QST-G1/4-10	10	
												132071	QST-G1/4-10-50	50		
G3/8	12	8	21	-	26.5	4.8	1.9	57.9	-	-	17	43	132597	QST-G1/4-12	1	
	8	6.7	14.5	-	27.2	5.8	2.4	49.4	-	-	19	34	186162	QST-G3/8-8	10	
													132072	QST-G3/8-8-50	50	
	10	8.3	17.5	-	28.2	5.8	2.4	54	-	-	19	41	186164	QST-G3/8-10	10	
													132073	QST-G3/8-10-20	20	
G1/2	12	10	21	-	28.7	5.8	2.4	59.4	-	-	19	47	186165	QST-G3/8-12	10	
													132074	QST-G3/8-12-20	20	
	16	11	25	4.2	44.2	5.8	2.4	66.2	24	12	24	97	186349	QST-G3/8-16	1	
	12	10.3	21	-	32.2	6.8	2.4	61.4	-	-	24	78	186166	QST-G1/2-12	1	
													186167	QST-G1/2-16	1	

1) 每包数量

技术参数

T 型快插接头 QST

气源管线数量: 1
 输出口数量: 2

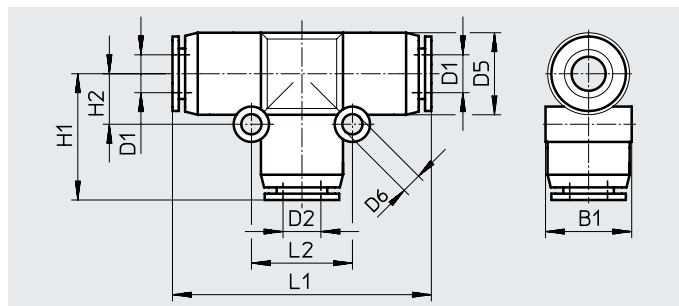

尺寸和订货数据													
气接口		公称通径	尺寸 [mm]							重量/件	订货号	型号	PS ¹⁾
适用气管外径	适用气管外径		D5 ∅	D6 ∅	B1	H1	H2	L1	L2				
D1	D2	[mm]								[g]			
4	4	2.8	10	3.2	10.4	17.2	6.5	34.4	13	7.5	★ 153128	QST-4	10
											130802	QST-4-100	100
6	6	4.8	13	3.2	13.5	20.1	8	40.2	16	11	★ 153129	QST-6	10
											130803	QST-6-100	100
8	8	6.2	15	3.2	15.6	22.2	9	44.4	18	16	★ 153130	QST-8	10
											130804	QST-8-50	50
10	10	8.1	17.5	4.2	18.2	25.2	12	50.4	24	25	★ 153131	QST-10	10
											130805	QST-10-50	50
12	12	10	21	4.2	21.7	28.4	14	56.8	28	36	★ 153132	QST-12	10
											130806	QST-12-20	20
16	16	13	25	4.2	25.6	33.1	12	66.2	24	44	153133	QST-16	1
变径													
6	4	2.3	13	3.2	13	19.5	8	40.1	16	11	★ 153134	QST-6-4	10
											130820	QST-6-4-100	100
8	4	2.3	14.5	3.2	15.1	21.7	9	44.4	18	14	★ 130613	QST-8-4	10
	6	3.5	14.5	3.2	15.1	22.3	9	44.4	18	14	★ 153135	QST-8-6	10
											130821	QST-8-6-50	50
10	6	3.7	17.5	4.2	18.2	25	12	50.4	24	22	★ 130614	QST-10-6	10
	8	4.9	17.5	4.2	18.2	24.9	12	50.4	24	23	★ 153136	QST-10-8	10
											130822	QST-10-8-50	50
12	8	5.1	21	4.2	21.7	27.7	14	56.8	28	32	★ 130615	QST-12-8	10
	10	6.1	21	4.2	21.7	28	14	56.8	28	34	★ 153137	QST-12-10	10
											130823	QST-12-10-20	20
16	12	7.6	25	4.2	25.7	33.2	12	66.2	24	45	★ 130616	QST-16-12	1

1) 每包数量

技术参数

T 型快插接头 QSTF

外和内螺纹, 带外六角, 可旋转

气源管线数量: 1

输出口数量: 2



R 螺纹

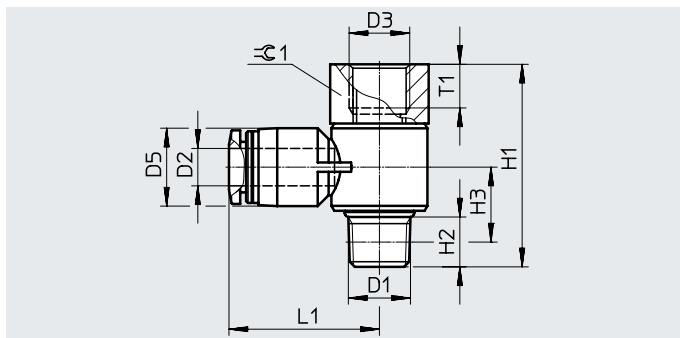

G 螺纹

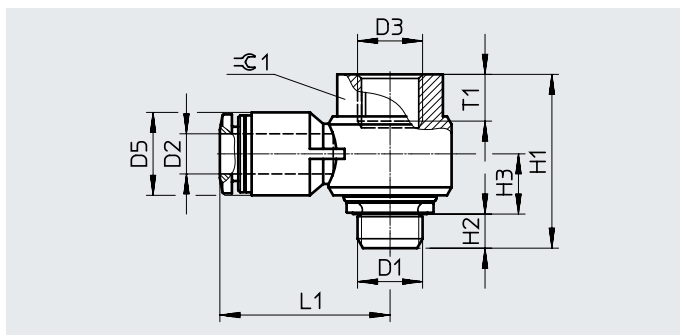

尺寸和订货数据

气接口		公称通径	尺寸 [mm]								重量/件	订货号	型号	PS ¹⁾
外螺纹	适用气管外径		D3	D5 ∅	H1	H2	H3	L1	T1	$\varnothing 1$				
D1	D2	[mm]									[g]			
R 螺纹														
R1/8	4	2.8	G1/8	10	32.5	8	12	22.2	7	14	22	153182	QSTF-1/8-4-B	1
	6	4.6	G1/8	12.5	32.5	8	12	24.2	7	14	23	153183	QSTF-1/8-6-B	1
	8	5.5	G1/8	14.5	32.5	8	12.3	26.2	7	14	25	153185	QSTF-1/8-8-B	1
R1/4	6	4.3	G1/4	12.5	38.5	11	13.5	26.8	9.5	17	37	153184	QSTF-1/4-6-B	1
	8	6	G1/4	14.5	38.5	11	13.5	28.2	9.5	17	38	153186	QSTF-1/4-8-B	1
	10	7.1	G1/4	17.5	38.5	11	15	30.5	9.5	17	41	153188	QSTF-1/4-10-B	1
R3/8	8	6	G3/8	14.5	44.5	12	15.7	30.2	11	21	61	153187	QSTF-3/8-8-B	1
	10	8	G3/8	18	44.5	12	15.7	32.5	11	21	64	153189	QSTF-3/8-10-B	1
	12	9.3	G3/8	21	44.5	12	17.2	35.2	11	21	67	153190	QSTF-3/8-12-B	1
R1/2	12	10	G1/2	21	52.2	13	16.5	38.2	14	24	100	153191	QSTF-1/2-12-B	1
G 螺纹, 带密封圈														
G1/8	4	3	G1/8	10	26	5.1	8.7	23.4	7	14	20	186199	QSTF-G1/8-4	1
	6	4	G1/8	12.4	26	5.1	9	25.5	7	14	21	186200	QSTF-G1/8-6	1
	8	5.6	G1/8	14.4	26	5.1	10	28.4	7	14	23	186202	QSTF-G1/8-8	1
G1/4	6	5	G1/4	14.5	33.2	5.6	10.4	29	9.5	19	43	186201	QSTF-G1/4-6	1
	8	6	G1/4	14.5	33.2	5.6	10.4	28.9	9.5	19	44	186203	QSTF-G1/4-8	1
	10	7	G1/4	17.6	33.2	5.6	11.7	31.2	9.5	19	47	186205	QSTF-G1/4-10	1
G3/8	8	6	G3/8	14.4	38.1	6.6	12.6	31	11	24	71	186204	QSTF-G3/8-8	1
	10	8	G3/8	17.6	38.1	6.6	12.6	33.6	11	24	74	186206	QSTF-G3/8-10	1
	12	8.7	G3/8	21	38.1	6.6	14.3	36.4	11	24	77	186207	QSTF-G3/8-12	1
G1/2	12	8.7	G1/2	21	42.8	7.6	14.3	37.9	14	27	99	186208	QSTF-G1/2-12	1

1) 每包数量

技术参数

T 型快插接头 QSTL

外螺纹, 带外六角, 可旋转

气源管线数量: 1

输出口数量: 2

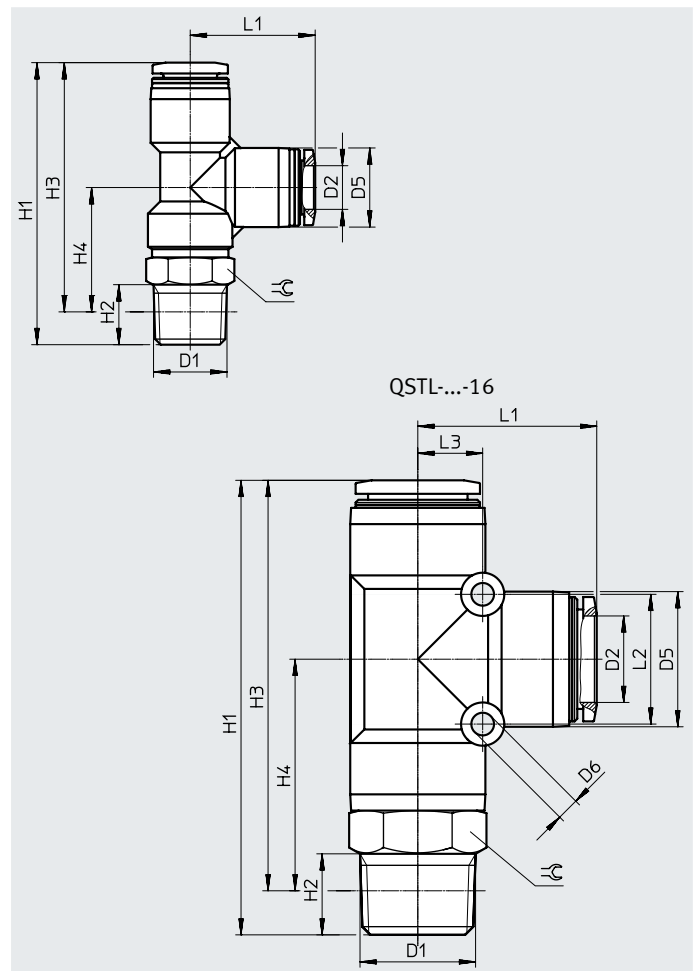

尺寸和订货数据		公称 口径	尺寸 [mm]										重量/件 [g]	订货号	型号	PS ¹⁾
气接口 外螺纹	适用气管外径		D5 ∅	D6 ∅	H1	H2	H3	H4	L1	L2	L3	≈C				
D1	D2	[mm]														
R 螺纹																
R1/8	4	2.8	10	-	40.2	8	36.2	19	17.2	-	-	10	13	★ 153117	QSTL-1/8-4	10
														130824	QSTL-1/8-4-100	100
	6	4.3	12.5	-	43.3	8	39.3	18.8	20.5	-	-	10	14	★ 153118	QSTL-1/8-6	10
														130825	QSTL-1/8-6-100	100
	8	6	14.5	-	46.9	8	42.9	20	22.9	-	-	12	19	★ 153120	QSTL-1/8-8	10
														130826	QSTL-1/8-8-50	50
R1/4	6	4.3	12.5	-	48.8	11	42.7	22.2	20.5	-	-	14	22	★ 153119	QSTL-1/4-6	10
														130827	QSTL-1/4-6-100	100
	8	6.7	14.5	-	51.7	11	45.7	22.8	22.9	-	-	14	25	★ 153121	QSTL-1/4-8	10
														130828	QSTL-1/4-8-50	50
	10	8	17.5	-	54.7	11	48.7	22.5	26.2	-	-	14	31	★ 153123	QSTL-1/4-10	10
														130829	QSTL-1/4-10-50	50
R3/8	8	6.7	14.5	-	55.4	12	49.1	26.2	22.9	-	-	17	35	★ 153122	QSTL-3/8-8	10
	10	8.3	17.5	-	58.2	12	51.9	25.7	26.2	-	-	17	42	★ 153124	QSTL-3/8-10	10
	12	10	21	-	63.5	12	57.2	26.7	30.5	-	-	17	48	★ 153125	QSTL-3/8-12	10
R1/2	12	10.3	21	-	67.5	15	59.3	28.8	30.7	-	-	21	72	★ 153126	QSTL-1/2-12	1
	16	13	25	4.2	84.1	15	75.9	42.8	33.1	24	12	22	93	153127	QSTL-1/2-16	1

1) 每包数量

技术参数

T 型快插接头 QSTL

外螺纹, 带外六角, 可旋转

气源管线数量: 1

输出口数量: 2

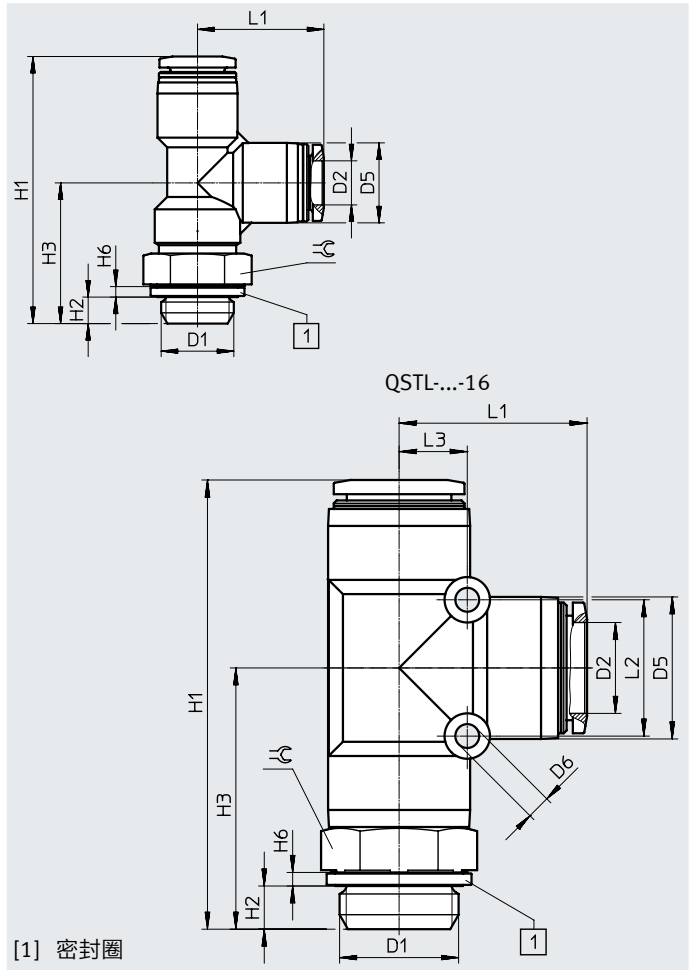

尺寸和订货数据														重量/件	订货号	型号	PS ¹⁾
气接口		公称 口径 [mm]	尺寸 [mm]														
外螺纹	适用气管外径		D5 ∅	D6 ∅	H1	H2	H3	H6	L1	L2	L3	≈C	[g]				
D1	D2																
G 螺纹, 带密封圈																	
G1/8	4	2.8	10	-	39.3	4.2	22.1	1.9	17.2	-	-	13	15	186168	QSTL-G1/8-4	10	
														132075	QSTL-G1/8-4-100	100	
	6	4.3	12.5	-	42.4	4.2	21.9	1.9	20.5	-	-	13	17	186169	QSTL-G1/8-6	10	
														132076	QSTL-G1/8-6-100	100	
	8	6	14.5	-	45	4.2	22.1	1.9	22.9	-	-	13	19	186171	QSTL-G1/8-8	10	
														132077	QSTL-G1/8-8-50	50	
G1/4	6	4.3	12.5	-	45.5	4.8	25	1.9	20.5	-	-	17	24	186170	QSTL-G1/4-6	10	
														132078	QSTL-G1/4-6-100	100	
	8	6.7	14.5	-	48.4	4.8	25.5	1.9	22.9	-	-	17	27	186172	QSTL-G1/4-8	10	
														132079	QSTL-G1/4-8-50	50	
	10	8	17.5	-	51.4	4.8	25.2	1.9	26.2	-	-	17	33	186174	QSTL-G1/4-10	10	
														132080	QSTL-G1/4-10-50	50	
G3/8	8	6.7	14.5	-	51.6	5.8	28.7	2.4	22.9	-	-	19	34	186173	QSTL-G3/8-8	10	
	10	8.3	17.5	-	54.4	5.8	28.2	2.4	26.2	-	-	19	41	186175	QSTL-G3/8-10	10	
	12	10	21	-	59.7	5.8	29.2	2.4	30.5	-	-	19	48	186176	QSTL-G3/8-12	10	
G1/2	12	10.3	21	-	63.2	6.8	32.7	2.4	30.7	-	-	24	78	186177	QSTL-G1/2-12	1	
	16	13	25	4.2	78.3	6.8	45.2	2.4	33.1	24	12	24	89	186178	QSTL-G1/2-16	1	

1) 每包数量

技术参数

快插接头 QSW

外螺纹, 带外六角, 可旋转

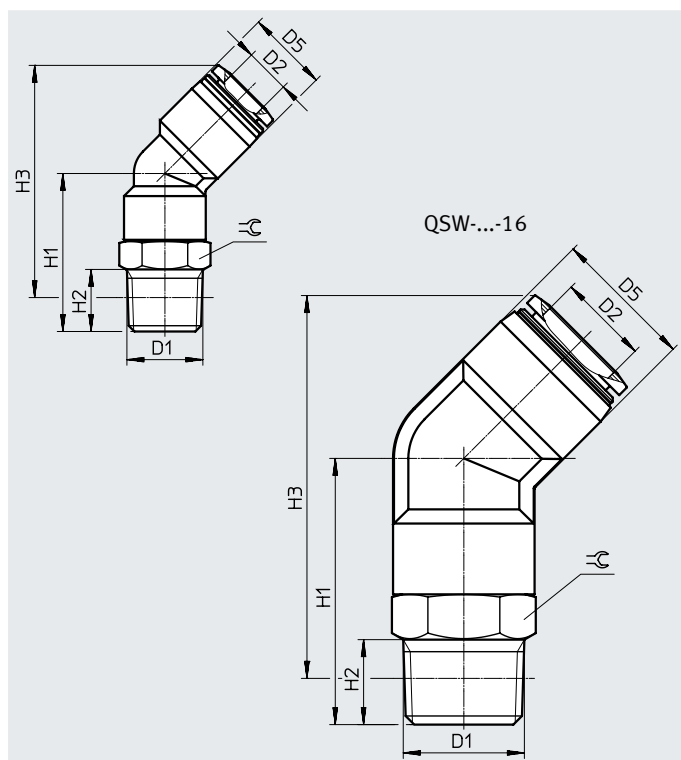

尺寸和订货数据											
气接口		公称通 径	尺寸 [mm]					重量/件	订货号	型号	PS ¹⁾
外螺纹	适用气管外径		D5 ∅	H1	H2	H3	⊘				
D1	D2	[mm]					[g]				
R 螺纹											
R1/8	4	2.5	8	14.8	8	23	10	6.1	130596	QSW-1/8-4	10
	6	3.3	10.5	16.4	8	25.3	10	6.8	130597	QSW-1/8-6	10
	8	6	14.5	24	8	39.2	12	14	130598	QSW-1/8-8	10
R1/4	6	3.3	10.5	21.4	11	28.2	14	17.9	130599	QSW-1/4-6	10
	8	6.7	14.5	28	11	41.2	14	20	130600	QSW-1/4-8	10
	10	8	17.5	28.5	11	44.9	14	23	130601	QSW-1/4-10	10
R3/8	10	8.3	17.5	33	12	49.1	17	35	130602	QSW-3/8-10	10
	12	9.5	21	32.5	12	53.2	17	38	130603	QSW-3/8-12	10
R1/2	12	10.3	21	36.5	15	55.4	21	61	130604	QSW-1/2-12	1
	16	13	25	47	15	67.6	22	78	130605	QSW-1/2-16	1

1) 每包数量

技术参数

快插接头 QSW-...HL 带插入式轴套

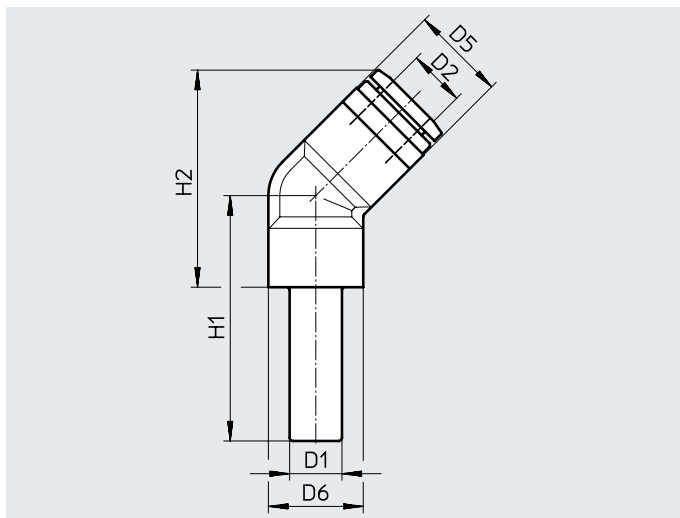

尺寸和订货数据		公称通径 [mm]	尺寸 [mm]				重量/件 [g]	订货号	型号	PS ¹⁾
气接口 插入式轴套 D1	适用气管外径 D2		D5	D6	H1	H2				
QS-4	4	2	8	8	21.8	15	1.4	130617	QSW-4HL	10
QS-6	6	2.7	10.5	8	24.6	17.3	2.1	130618	QSW-6HL	10
QS-8	8	5	14.5	10	28.5	25.7	5.8	130619	QSW-8HL	10
QS-10	10	6.3	17.5	11	31.5	30.5	9.5	130620	QSW-10HL	10
QS-12	12	6.9	21	14	35.5	36.3	14.5	130621	QSW-12HL	10

1) 每包数量

X 型快插接头 QSX

气源管线数量: 1
输出口数量: 3

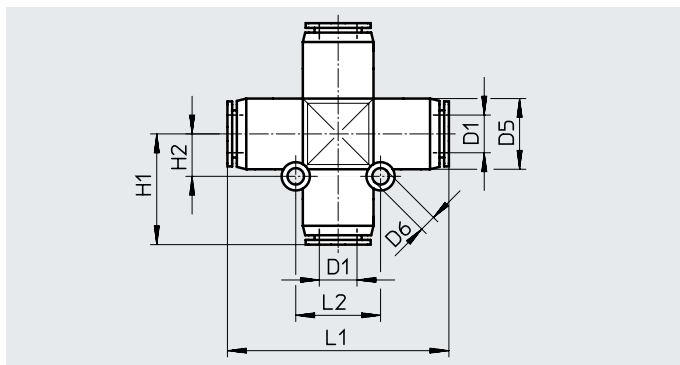

尺寸和订货数据		公称通径 [mm]	尺寸 [mm]					重量/件 [g]	订货号	型号	PS ¹⁾
气接口 适用气管外径 D1	适用气管外径 D2		D5 ∅	D6 ∅	H1	H2	L1				
8	4.7	15	3.5	23.5	9	47	18	20	153285	QSX-8	10
10	6.1	17.5	4.5	27.5	11	55	22	32	153286	QSX-10	10
12	7.5	21	4.5	31	12	62	24	46	153287	QSX-12	10

1) 每包数量

技术参数

Y型快插接头 QSY

外螺纹, 带外六角, 可旋转

气源管线数量: 1

输出口数量: 2



M 螺纹

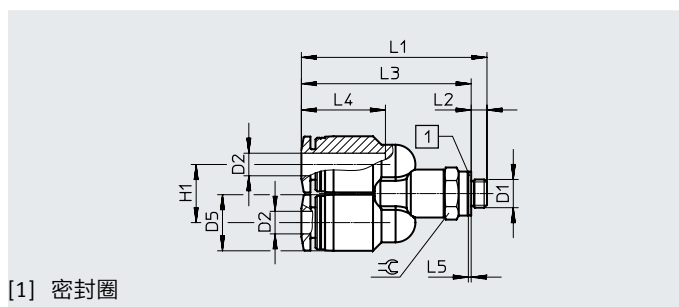

[1] 密封圈



R 螺纹

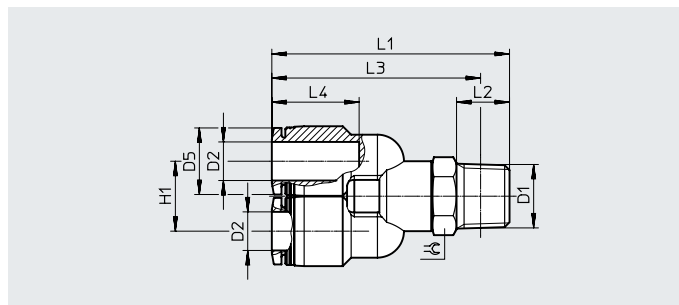

尺寸和订货数据		公称通径	尺寸 [mm]								重量/件	订货号	型号	PS ¹⁾	
气接口	适用气管外径		D5 ø	H1	L1	L2	L3	L4	L5	⌀					
D1	D2	[mm]	[g]												
公制螺纹, 带密封圈															
M5x0.8	4	2.4	10	10.3	32.9	2.8	30.1	14.9	0.5	8	8	★ 190673	QSY-M5-4	10	
	6	2.4	12.5	12.5	38.3	2.8	35.5	17	0.5	10	13	★ 190674	QSY-M5-6	10	
R 螺纹															
R1/8	4	3.1	10	10.3	38.4	8	34.4	14.9	-	10	13	★ 153138	QSY-1/8-4	10	
	6	4.2	12.5	12.5	41.3	8	37.3	17	-	10	15	★ 153139	QSY-1/8-6	10	
	8	5.9	14.5	14.5	46.1	8	42.1	18.1	-	12	20	★ 153141	QSY-1/8-8	10	
R1/4	4	3.3	10	10.3	43.4	11	37.4	14.9	-	14	20	★ 190675	QSY-1/4-4	10	
	6	4.8	12.5	12.5	48.3	11	42.2	17	-	14	22	★ 153140	QSY-1/4-6	10	
	8	6.2	14.5	14.5	49.3	11	43.3	18.1	-	14	25	★ 153142	QSY-1/4-8	10	
	10	7.2	17.5	17.5	53.6	11	47.6	20.2	-	14	32	★ 153144	QSY-1/4-10	10	
R3/8	8	6.6	14.5	14.5	52.5	12	46.2	18.1	-	17	36	★ 153143	QSY-3/8-8	10	
	10	7.4	17.5	17.5	56.7	12	50.4	20.2	-	17	43	★ 153145	QSY-3/8-10	10	
	12	8.4	21	21	60.6	12	54.3	23.4	-	17	51	★ 153146	QSY-3/8-12	10	
R1/2	10	7.8	17.5	17.5	60.2	15	52	20.2	-	21	66	133196	QSY-1/2-10	10	
	12	8.3	21	21	64.7	15	56.5	23.4	-	21	74	★ 153147	QSY-1/2-12	1	

1) 每包数量

快插接头 QS, 标准

技术参数

Y 型快插接头 QSY

外螺纹, 带外六角, 可旋转

气源管线数量: 1

输出口数量: 2

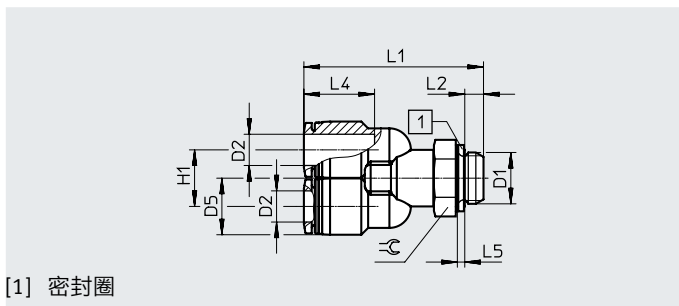

尺寸和订货数据													
气接口		公称通径	尺寸 [mm]							重量/件	订货号	型号	PS ¹⁾
外螺纹	适用气管外径		D5 ∅	H1	L1	L2	L4	L5	≅				
D1	D2	[mm]							[g]				
G 螺纹, 带密封圈													
G1/8	4	3.1	10	10.3	37.5	4.2	14.9	1.9	13	15	186179	QSY-G1/8-4	10
	6	4.2	12.5	12.5	40.4	4.2	17	1.9	13	17	186180	QSY-G1/8-6	10
	8	5.9	14.5	14.5	44.2	4.2	18.1	1.9	13	20	186182	QSY-G1/8-8	10
G1/4	6	4.8	12.5	12.5	45	4.8	17	1.9	17	25	186181	QSY-G1/4-6	10
	8	6.2	14.5	14.5	46	4.8	18.1	1.9	17	28	186183	QSY-G1/4-8	10
	10	7.2	17.5	17.5	50.3	4.8	20.2	1.9	17	35	186185	QSY-G1/4-10	10
G3/8	8	6.6	14.5	14.5	48.7	5.8	18.1	2.4	19	35	186184	QSY-G3/8-8	10
	10	7.4	17.5	17.5	52.9	5.8	20.2	2.4	19	42	186186	QSY-G3/8-10	10
	12	8.4	21	21	56.8	5.8	23.4	2.4	19	50	186187	QSY-G3/8-12	10
G1/2	12	8.3	21	21	60.4	6.8	23.4	2.4	24	80	186188	QSY-G1/2-12	1

1) 每包数量

技术参数

Y型快插接头 QSY

气源管线数量: 1
 输出口数量: 2

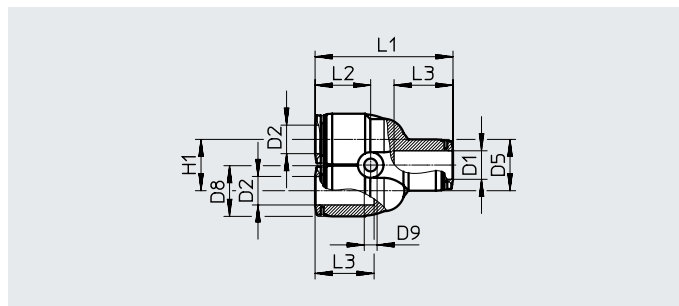

2 变径 outlets



变径

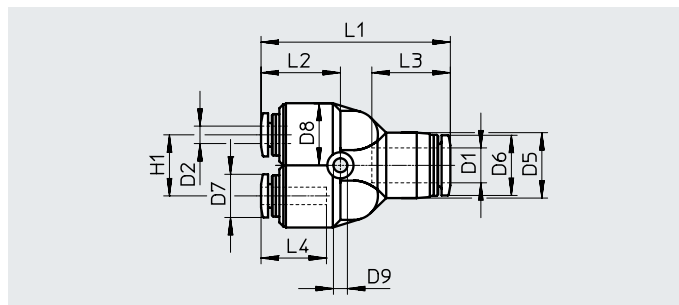

尺寸和订货数据		公称 口径	尺寸 [mm]										重量/件	订货号	型号	PS ¹⁾
气接口 适用气管外径	适用气管外径		D5 ∅	D6 ∅	D7 ∅	D8 ∅	D9 ∅	H1	L1	L2	L3	L4				
D1	D2	[mm]											[g]			
4	4	2.6	10	-	-	10	3.2	11	32.8	14.1	14.9	-	7.6	★ 153148	QSY-4	10
														130807	QSY-4-100	100
6	6	4.3	13	-	-	12.5	3.4	12	37.7	15.8	17	-	11	★ 153149	QSY-6	10
														130808	QSY-6-100	100
8	8	5.7	15	-	-	14.5	3.4	14	42.4	17.2	18.1	-	16	★ 153150	QSY-8	10
														130809	QSY-8-50	50
10	10	6.7	17.5	-	-	17.5	4.2	18	48.4	19.5	20.7	-	26	★ 153151	QSY-10	10
														130810	QSY-10-20	20
12	12	8	21	-	-	21	4.2	20	54.9	22.3	23.4	-	37	★ 153152	QSY-12	10
														130811	QSY-12-20	20
16	16	12.7	25	-	-	25	4.5	24	62.2	22.1	24.1	-	45	130609	QSY-16	1
变径																
6	4	2.3	13	11.8	9.9	12.5	3.4	12	37.2	15.2	17	14.9	11	★ 153153	QSY-6-4	10
														130812	QSY-6-4-100	100
8	4	1.7	14.5	13.8	9.9	12.5	3.4	14	41.9	16.7	18.1	14.9	13	★ 130610	QSY-8-4	10
	6	3.2	14.5	13.8	11.8	12.5	3.4	14	42.5	17.3	18.1	17	13	★ 153154	QSY-8-6	10
														130813	QSY-8-6-50	50
10	6	3.3	17.5	16.8	11.8	14.5	4.5	18	48.2	19.3	20.2	17	19	★ 130611	QSY-10-6	10
	8	4.5	17.5	16.8	13.8	14.5	4.5	18	48.1	19.2	20.2	18.1	20	★ 153155	QSY-10-8	10
														130814	QSY-10-8-20	20
12	8	4.5	21	19.8	13.8	17.5	4.5	20	54.3	21.7	23.4	18.1	27	★ 130612	QSY-12-8	10
	10	5.8	21	19.8	16.8	17.5	4.5	20	54.6	22	23.4	20.2	30	★ 153156	QSY-12-10	10
														130815	QSY-12-10-20	20
16	12	7	25	23	19.8	25	4.5	24	62.3	22.2	24.1	23.4	48	★ 190708	QSY-16-12	1

1) 每包数量

快插接头 QS, 标准

技术参数

Y 型快插接头 QSY...H

带插入式轴套

气源管线数量: 1

输出口数量: 2

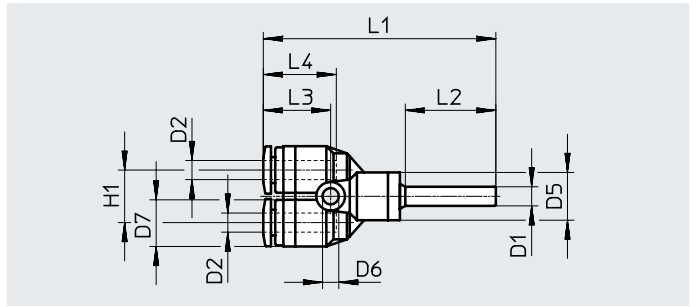

尺寸和订货数据		公称通径	尺寸 [mm]								重量/件	订货号	型号	PS ¹⁾
气接口	适用气管外径		D5 ∅	D6 ∅	D7 ∅	H1	L1	L2	L3	L4				
插入式轴套	D1	D2	[mm]								[g]			
QS-4	4	1.6	10	3.2	10	11	48.7	19	14.1	14.9	6.5	130628	QSY-4H	10
变径														
QS-6	4	2.3	10	3.2	10	11	50.9	22	14.1	14.9	6.8	130633	QSY-6H-4	10

1) 每包数量

Y 型快插接头 QSY...H-B

带插入式轴套

气源管线数量: 1

输出口数量: 2

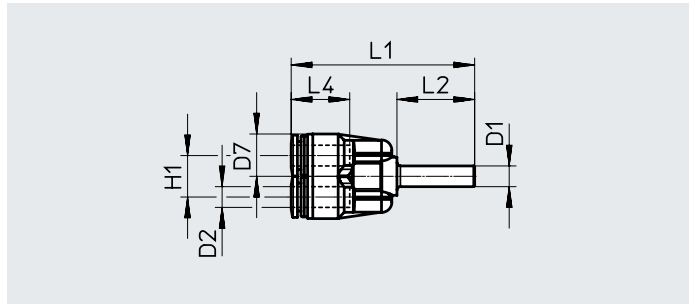

尺寸和订货数据		公称通径	尺寸 [mm]					重量/件	订货号	型号	PS ¹⁾
气接口	适用气管外径		D7 ∅	H1	L1	L2	L4				
插入式轴套	D1	D2	[mm]								
QS-6	6	3.1	12.5	12	53.2	22.5	17	8.5	133145	QSY-6H-B	10
QS-8	8	4.6	14.5	14	56.1	23.5	18.1	13	133146	QSY-8H-B	10
QS-10	10	5.9	17.5	18	63.2	25	20.2	21	133148	QSY-10H-B	10
QS-12	12	7.3	21	20	71.3	29	23.4	31	133150	QSY-12H-B	10
变径											
QS-8	6	3.6	12.5	12	54.2	23.5	17	8.8	133147	QSY-8H-6-B	10
QS-10	8	4.6	14.5	14	57.6	25	18.1	13	133149	QSY-10H-8-B	10
QS-12	10	5.9	17.5	18	67.2	29	20.2	22	133151	QSY-12H-10-B	10

1) 每包数量

技术参数

Y型快插接头 QSYL

外螺纹, 带外六角, 可旋转

气源管线数量: 1

输出口数量: 2



R 螺纹

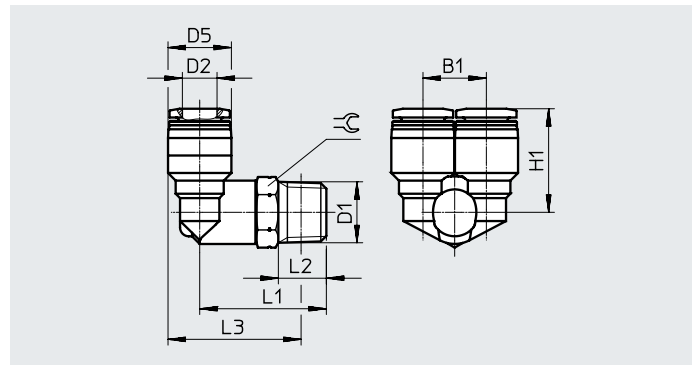

G 螺纹

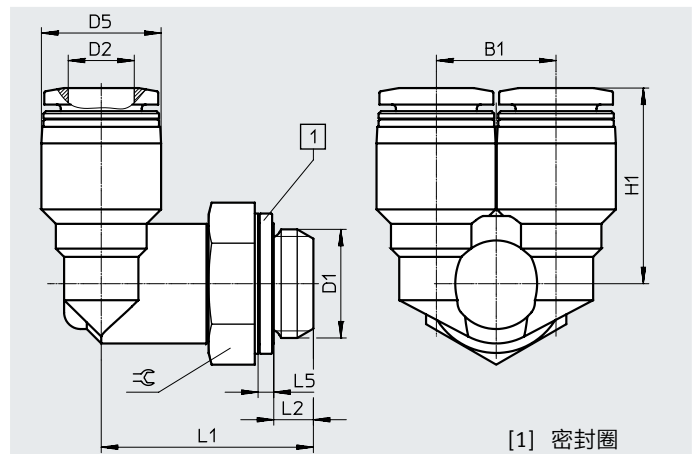

[1] 密封圈

尺寸和订货数据		公称通径	尺寸 [mm]								重量/件	订货号	型号	PS ¹⁾
气接口	适用气管外径		B1	D5 ∅	H1	L1	L2	L3	L5	≈e				
D1	D2	[mm]									[g]			
R 螺纹														
R1/8	4	3.9	10.3	10	18.2	23	8	24	-	10	13	★ 153172	QSYL-1/8-4	1
	6	4.2	12.5	12.5	19.8	23.5	8	25.8	-	10	15	★ 153173	QSYL-1/8-6	1
	8	5.7	14.5	14.5	22.7	25	8	28.3	-	12	20	★ 153175	QSYL-1/8-8	1
R1/4	6	5.3	12.5	12.5	21.8	29	11	29.2	-	14	22	★ 153174	QSYL-1/4-6	1
	8	7.3	14.5	14.5	23.7	29	11	30.2	-	14	25	★ 153176	QSYL-1/4-8	1
	10	8	17.5	17.5	26	29.5	11	32.2	-	14	32	★ 153178	QSYL-1/4-10	1
R3/8	8	7.3	14.5	14.5	24.7	32	12	32.9	-	17	37	★ 153177	QSYL-3/8-8	1
	10	9.2	17.5	17.5	27	32.5	12	34.9	-	17	43	★ 153179	QSYL-3/8-10	1
	12	9.7	21	21	29.2	33.5	12	37.7	-	17	51	★ 153180	QSYL-3/8-12	1
R1/2	12	10.6	21	21	30.2	38	15	40.3	-	21	74	★ 153181	QSYL-1/2-12	1
G 螺纹, 带密封圈														
G1/8	4	3.9	10.3	10	18.2	22.1	4.2	-	1.9	13	16	186189	QSYL-G1/8-4	1
	6	4.2	12.5	12.5	19.8	22.6	4.2	-	1.9	13	18	186190	QSYL-G1/8-6	1
	8	5.7	14.5	14.5	22.7	23.1	4.2	-	1.9	13	20	186192	QSYL-G1/8-8	1
G1/4	6	5.3	12.5	12.5	21.8	25.7	4.8	-	1.9	17	26	186191	QSYL-G1/4-6	1
	8	7.3	14.5	14.5	23.7	25.7	4.8	-	1.9	17	29	186193	QSYL-G1/4-8	1
	10	8	17.5	17.5	26	26.2	4.8	-	1.9	17	36	186195	QSYL-G1/4-10	1
G3/8	8	7.3	14.5	14.5	24.7	28.2	5.8	-	2.4	19	38	186194	QSYL-G3/8-8	1
	10	9.2	17.5	17.5	27	28.7	5.8	-	2.4	19	45	186196	QSYL-G3/8-10	1
	12	9.7	21	21	29.2	29.7	5.8	-	2.4	19	52	186197	QSYL-G3/8-12	1
G1/2	12	10.6	21	21	30.2	33.7	6.8	-	2.4	24	80	186198	QSYL-G1/2-12	1

1) 每包数量

技术参数

Y型快插接头 QSYLV

外螺纹, 带外六角, 可旋转

气源管线数量: 1

输出口数量: 2

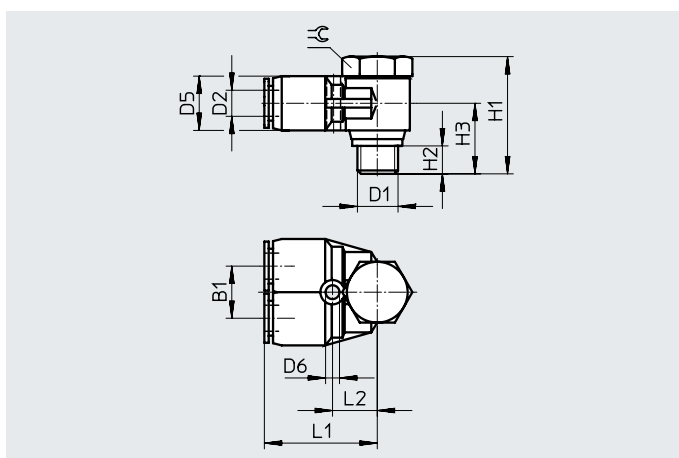
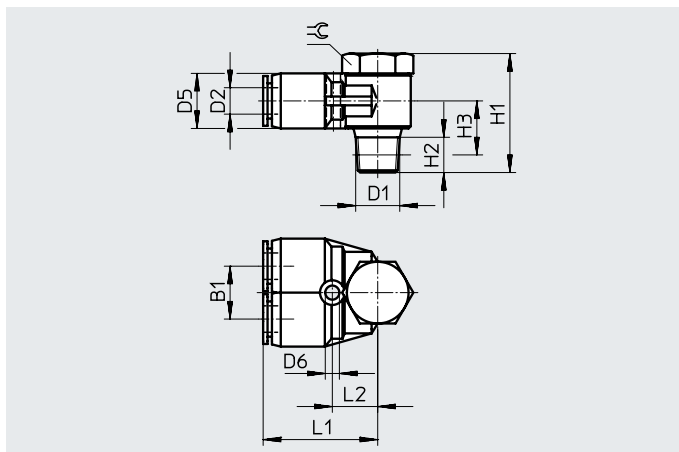

尺寸和订货数据

气接口		公称通径 [mm]	尺寸 [mm]										重量/件 [g]	订货号	型号	PS ¹⁾	
外螺纹	适用气管外径		B1	D5 ∅	D6 ∅	H1	H2	H3	L1	L2	≈						
D1	D2	[mm]															
R 螺纹																	
R1/8	6	3.3	12	12.5	3.2	27	8	11	26	10.5	14	24.5	153192	QSYLV-1/8-6	1		
R1/4	8	4.4	14	14.5	3.2	31.5	11	12.5	29	12.5	17	41.5	153193	QSYLV-1/4-8	1		
R3/8	10	5.7	17	17.5	4.2	36	12	14.5	33.5	15	21	69.5	153194	QSYLV-3/8-10	1		
R1/2	12	7.1	20	21	4.2	40	15	17.5	37.5	17	24	102	153195	QSYLV-1/2-12	1		
G 螺纹, 带密封圈																	
G1/8	6	3.5	12	12.4	3.2	26.2	5.1	15.2	27.5	12	17	31	186209	QSYLV-G1/8-6	1		
G1/4	8	4.7	14	14.4	3.2	28.4	5.6	16.4	30.9	14	19	48	186210	QSYLV-G1/4-8	1		
G3/8	10	5.2	17	17.6	4.2	33.4	6.6	19.4	34	15.5	21	73	186211	QSYLV-G3/8-10	1		
G1/2	12	7	20	21	4.2	37.4	7.6	21.9	38.9	18.5	27	123	186212	QSYLV-G1/2-12	1		

1) 每包数量

附件

解锁工具 QSO

解锁工具用于从位置尴尬的接头拔出气管。

**尺寸和订货数据**

适用气管外径

适用气管外径	重量/件 [g]	订货号	型号
4, 6, 8, 10	13	158419	QSO