

快拧接头

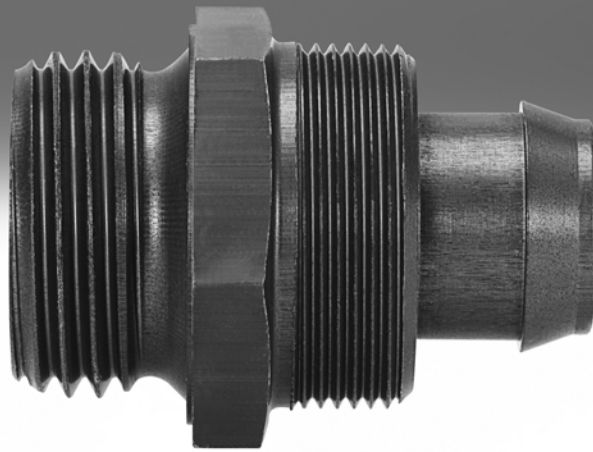



FESTO



快拧接头 CK/CX

产品范围一览







FESTO

结构特点	类型	型号	接口 D1		气管 内螺纹	不含铜、聚四氟乙 烯和硅	→ 页码
			M 螺纹	G 螺纹			
直列式	快拧接头 - 内螺纹, 带密封圈						
		ACK 金属型	-	G 1/8	3, 4, 6	■	NO TAG
				G 1/4	4, 6		
				G 3/8	6, 9		
				G 1/2	13		
	快拧接头 - 外螺纹, 带密封圈						
		CK 金属型	M5	-	3, 4	■	NO TAG
			-	G 1/8	3, 4, 6		
				G 1/4	4, 6, 9		
				G 3/8	6, 9, 13		
				G 1/2	13		
	CK-...-KU 塑料结构	-	G 1/8	3, 4, 6	■	NO TAG	
			G 1/4	4, 6, 9			
			G 3/8	6, 9			
	穿板式快拧接头 - 内螺纹, 带密封圈						
		QCK	M5	-	3	■	7
			-	G 1/8	4		
G 1/4				6			
G 3/8				9			
穿板式快拧接头							
	SCK 金属型	-	-	3, 4, 6, 9	■	8	
	SCK-...-KU 塑料结构	-	-	3, 4, 6, 9	■	8	
端盖, 用于塑料气管接头和倒钩接头							
	CV-PK	-	-	3, 4, 6, 9	-	9	

快拧接头 CK/CX

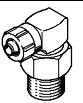
产品范围一览

FESTO

结构特点	结构特点	型号	接口 D1			气管 内螺纹	不含铜、聚四 氟乙烯和硅	→ 页码	
			M 螺纹	R 螺纹	G 螺纹				
L形	L形快拧接头								
		GCK-...-KU	-	R $\frac{1}{8}$ R $\frac{1}{4}$ R $\frac{3}{8}$	-	4, 6 4, 6 6, 9	■	10	
	L形快拧接头, 可旋转, 带 2个密封圈								
		LCK 金属型	M5	-	- G $\frac{1}{8}$ G $\frac{1}{4}$ G $\frac{3}{8}$ G $\frac{1}{2}$	3, 4 3, 4, 6 4, 6, 9 6, 9, 13 13	■	11	
		LCK-...-KU 塑料结构	-	-	G $\frac{1}{8}$ G $\frac{1}{4}$	4, 6 4, 6	■	11	
	L形快拧接头, 带 密封圈 (旋转 360°)								
		LCKN	M5	-	- G $\frac{1}{8}$ G $\frac{1}{4}$ G $\frac{3}{8}$	3, 4 3, 4, 6 4, 6 6	-	12	
	T形	T快拧接头, 可旋转, 带 2个密封圈							
			TCK 金属型	M5	-	- G $\frac{1}{8}$ G $\frac{1}{4}$ G $\frac{3}{8}$ G $\frac{1}{2}$	3, 4 3, 4, 6 4, 6 6, 9 13	■	13
			TCK-...-KU 塑料结构	-	-	G $\frac{1}{8}$ G $\frac{1}{4}$	4, 6 4, 6	■	13
T形分气接头									
		FCK-...-KU	-	-	-	3 4 6 9	■	NO TAG	
锁定螺母, 用于CK气管接头									
		MCK 金属型	-	-	-	3, 4, 6, 9, 13	-	15	
	MCK-...-KU 塑料结构	-	-	-	3, 4, 6, 9	-	15		

快拧接头 CK/CX

产品范围一览

FESTO

结构特点	结构特点	型号	接口 D1		气管内螺纹	不含铜、聚四氟乙 烯和硅	→ 页码
			M 螺纹	G 螺纹			
中空复合 分气接头	环形管接头, 带 2 个密封圈						
		LK 金属型	M5	-	3, 4	-	16
			-	G1/8	3, 4, 6		
			-	G1/4	4, 6		
			-	G3/8	6		
	LK-...-KU 塑料结构	-	G1/8	4, 6	-	16	
		-	G1/4	4, 6			
	环形管接头, 带 2 个密封圈						
		TK 金属型	M5	-	3, 4	-	NO TAG
			-	G1/8	3, 4, 6		
			-	G1/4	4, 6		
			-	G3/8	6		
TK-...-KU 塑料结构	-	G1/8	4, 6	-	NO TAG		
	-	G1/4	4, 6				
中空螺栓型, 带 2 个环形管接头							
	VT-...-2 2 个环形管接 头	M5	G1/8	3, 4, 6	-	18	
			G1/4	4, 6			
			G3/8	6			
			VT-...-3 3 个环形管接 头	M5			G1/8
G1/4	4, 6						
G3/8	6						
用于金属倒钩软管 PX							
直列式	快拧接头						
		ACX	-	G1/8	4	-	19
				G1/4	6		
				G3/8	9		
	快拧接头						
		CX	-	G1/8	4, 6	-	19
G1/4				4, 6			
G3/8				9			
L形	L形快拧接头						
		LCX	-	G1/8	4	-	NO TAG
				G1/4	6		
				G3/8	9		
T形	T形快拧接头						
		TCX	-	G1/8	4	-	20
				G1/4	6		
				G3/8	9		

快拧接头 ACK

技术参数

FESTO

快拧接头ACK

内螺纹，带密封圈

材料:

蓝色阳极氧化铝

不含铜和聚四氟乙烯

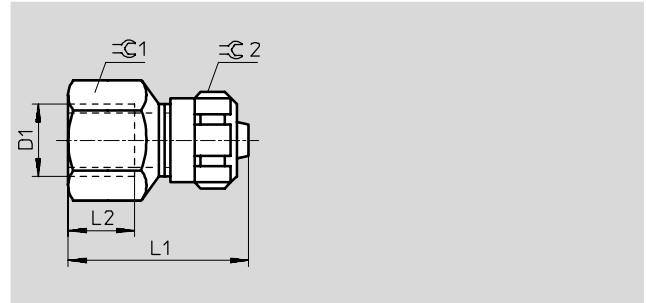

尺寸和订货数据									
接口 D1	公称通径 [mm]	气管内径	L1	L2	1	2	订货号	型号	PU*
G1/8	2.4	3	23.9	9	13	8	5 664	ACK-1/8-PK-3	10
	3.4	4	27	9	13	12	3 714	ACK-1/8-PK-4	10
	5.3	6	27	9	13	14	7 842	ACK-1/8-PK-6	10
G1/4	3.4	4	30	12	17	12	3 713	ACK-1/4-PK-4	10
	5.3	6	30	12	17	14	3 712	ACK-1/4-PK-6	10
G3/8	5.3	6	31	12	19	14	3 711	ACK-3/8-PK-6	10
	8	9	37.4	15	19	19	3 710	ACK-3/8-PK-9	1
G1/2	12	13	40.2	15	27	24	4 099	ACK-1/2-PK-13	1

* 包装单位数量

快拧接头 CK

技术参数

FESTO

快拧接头 CK

外螺纹，带密封圈

材料:

M螺纹，带铝

G螺纹，带阳极氧化铝

不含铜和聚四氟乙烯

认证: 德国劳氏

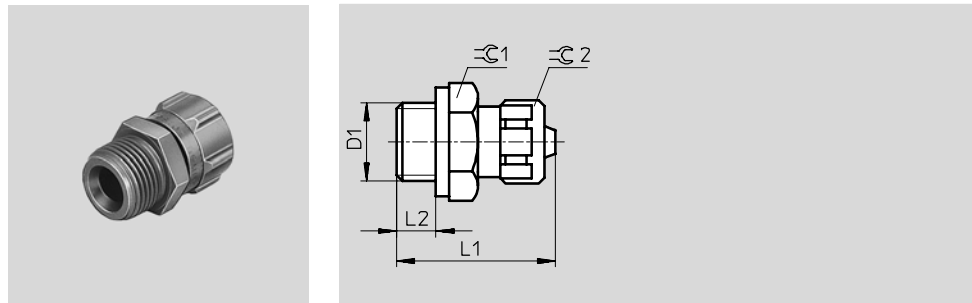

快拧接头 CK...-KU

外螺纹，带模塑密封圈

材料:

聚醋酸酯

不含铜和聚四氟乙烯

符合RoHS规定

压力范围: 0 ... 10 bar

温度范围: -10 ... +60 °C

认证: 德国劳氏

尺寸和订货数据

接口 D1	公称通径 [mm]	气管内径	L1	L2	≈C	≈C1	订货号	型号	PU*
金属型									
M5	2.0	3	19.3	3.8	7	8	3 561	CK-M5-PK-3	10
	2.9	4	21.5	3.8	10	-	3 562	CK-M5-PK-4	10
G1/8	2.0	3	21.6	4.9	13	8	3 563	CK-1/8-PK-3	10
	2.9	4	24.7	4.9	13	12	2 027	CK-1/8-PK-4	10
	4.9	6	24.8	4.9	13	14	2 028	CK-1/8-PK-6	10
G1/4	2.9	4	27.2	5.8	17	12	2 029	CK-1/4-PK-4	10
	4.9	6	27.3	5.8	17	14	2 030	CK-1/4-PK-6	10
	8	9	30.6	5.8	17	19	2 031	CK-1/4-PK-9	10
G3/8	4.9	6	28.3	6.8	19	14	2 032	CK-3/8-PK-6	10
	8	9	31.6	6.8	19	19	2 033	CK-3/8-PK-9	10
	11.7	13	33.2	6.8	24	24	4 097	CK-3/8-PK-13	10
G1/2	11.7	13	34.7	8.5	24	24	4 098	CK-1/2-PK-13	1
塑料结构									
G1/8	2.4	3	22.2	6.5	13	8	6 253	CK-1/8-PK-3-KU	10
	3.4	4	25.3	6.5	13	12	6 254	CK-1/8-PK-4-KU	10
	4.4	6	25.4	6.5	13	14	6 255	CK-1/8-PK-6-KU	10
G1/4	3.4	4	28.5	8.5	17	12	6 256	CK-1/4-PK-4-KU	10
	5.3	6	28.6	8.5	17	14	6 257	CK-1/4-PK-6-KU	10
	7.3	9	31.9	8.5	17	19	6 258	CK-1/4-PK-9-KU	10
G3/8	5.3	6	31	10.5	19	14	6 460	CK-3/8-PK-6-KU	10
	8	9	34.5	10.5	19	19	6 468	CK-3/8-PK-9-KU	10

* 包装单位数量

穿板式快拧接头 QCK

技术参数

FESTO

穿板式快拧接头 QCK
内螺纹，带密封圈

材料：
蓝色阳极氧化铝/钢
不含铜和聚四氟乙烯

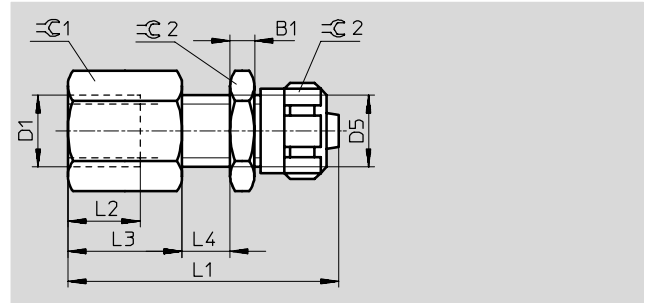

尺寸和订货数据														
接口	公称通径	气管内径	B1	D5	L1	L2	L3	L4	≈C1	≈C2	≈C3	订货号	型号	PU*
D1	[mm]							max.						
M5	2.4	3	3.2	M6x0.75	31	6	10	8	7	8	10	9 424	QCK-M5-PK-3-B	1
G $\frac{1}{8}$	3.4	4	3.5	M10x1	40	8	13.5	10	13	12	13	9 425	QCK- $\frac{1}{8}$ -PK-4-B	1
G $\frac{1}{4}$	5.3	6	4	M12x1	45	12	18	10	17	14	17	9 426	QCK- $\frac{1}{4}$ -PK-6-B	1
G $\frac{3}{8}$	8	9	5	M16x1	50	12	18.6	10	19	19	22	9 427	QCK- $\frac{3}{8}$ -PK-9-B	1

* 包装单位数量

穿板式快拧接头 SCK

技术参数

FESTO

穿板式快拧接头 SCK

材料:
蓝色阳极氧化铝/钢
不含铜和聚四氟乙烯

穿板式快拧接头 SCK-...-KU

带模塑密封圈

材料:
聚醋酸酯
不含铜和聚四氟乙烯
符合RoHS规定

压力范围: 0 ... 10 bar
温度范围: -10 ... +60 °C

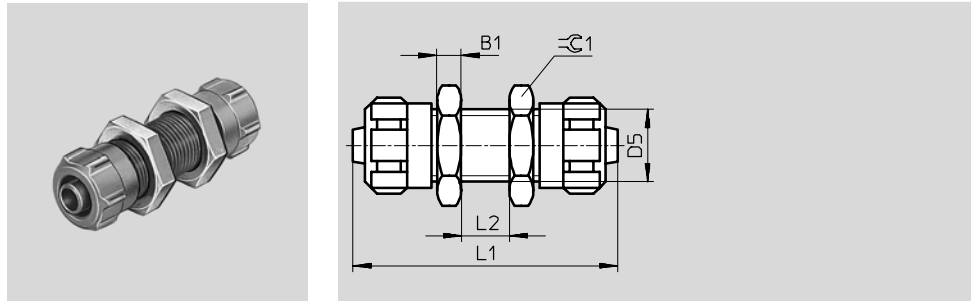

尺寸和订货数据									
公称通径	气管内径	B1	D5	L1	L2 max.	±C1	订货号	型号	PU*
[mm]									
铝制结构									
2.4	3	3.2	M6x0.75	34	8	10	9 420	SCK-PK-3	1
3.4	4	3.5	M10x1	43	10	13	9 421	SCK-PK-4	1
5.3	6	4	M12x1	44	10	17	9 422	SCK-PK-6	1
8	9	5	M16x1	53	10	22	9 423	SCK-PK-9	1
塑料结构									
2.4	3	5	M10x1 ¹⁾	41	10	13	9 387	SCK-PK-3-KU	10
3.4	4	5	M10x1	46		13	9 388	SCK-PK-4-KU	10
5.3	6	6	M12x1	48		17	9 389	SCK-PK-6-KU	10
8	9	7	M16x1	57		22	9 390	SCK-PK-9-KU	1

* 包装单位数量
1) 安装直径与铝制结构的不同

端盖 CV

技术参数

端盖 CV

用于密封塑料气管倒钩接头

材料:

聚氨酯

不含铜和聚四氟乙烯

符合RoHS规定

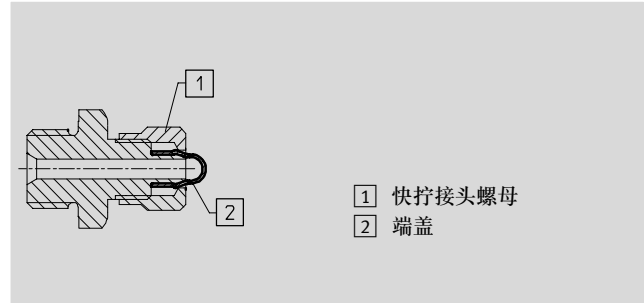

- 1 快拧接头螺母
- 2 端盖

尺寸和订货数据				
气管内径	每件重量 [g]	订货号	型号	PU*
3	0.001	6 213	CV-PK-3-B	10
4	0.001	6 214	CV-PK-4-B	10
6	0.001	6 215	CV-PK-6-B	10
9	0.002	6 216	CV-PK-9-B	10

工作条件 (许用静态压力)								
型号	CV-PK-3-B ... CV-PK-6-B						CV-PK-9-B	
工作压力 [bar]	10	10	8	7	6	6	6	4
环境温度 [°C]	-35	+20	+40	+60	+80	+80	+60	+80

* 包装单位数量

L形快拧接头 GCK

技术参数

FESTO

L形快拧接头 GCK...-KU

材料:
聚醋酸酯
不含铜和聚四氟乙烯
符合RoHS规定

压力范围: 0 ... 10 bar
温度范围: -10 ... +60 °C

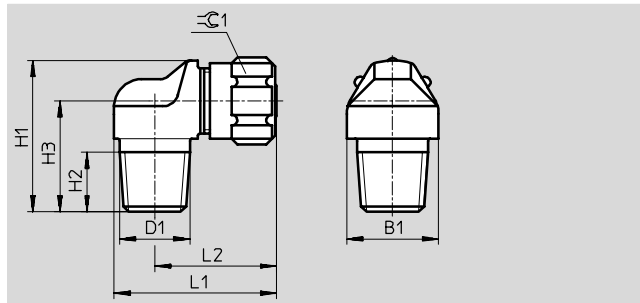

尺寸和订货数据												
接口 D1	公称通径 [mm]	气管内径	B1	H1	H2	H3	L1	L2	± 0.1	订货号	型号	PU*
R $\frac{1}{8}$	2.9	4	13	22.5	8	16.5	26.5	20.5	20.5	6 267	GCK- $\frac{1}{8}$ -PK-4-KU	10
	4.9	6	17	24.5	8	17.5	28.5	21.5	21.5	6 268	GCK- $\frac{1}{8}$ -PK-6-KU	10
R $\frac{1}{4}$	2.9	4	17	25.5	11	19.5	30	22.5	22.5	6 269	GCK- $\frac{1}{4}$ -PK-4-KU	10
	4.9	6	17	27.5	11	20.5	30	22.5	22.5	6 270	GCK- $\frac{1}{4}$ -PK-6-KU	10
R $\frac{3}{8}$	4.9	6	19	28.5	10.5	21	34	24.5	24.5	6 271	GCK- $\frac{3}{8}$ -PK-6-KU	10
	8	9	19	33.5	10.5	23.5	37.2	27.7	27.7	6 272	GCK- $\frac{3}{8}$ -PK-9-KU	10

* 包装单位数量

L形快拧接头 LCK

技术参数

FESTO

L形快拧接头 LCK

可旋转，带2个密封圈

材料:

压铸锌

不含铜和聚四氟乙烯

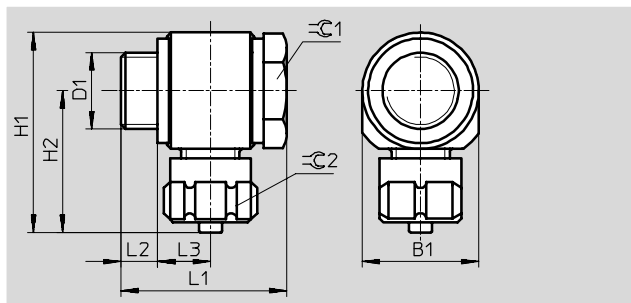

L形快拧接头

LCK-...-KU

可旋转，带圈

材料:

聚醋酸酯

不含铜和聚四氟乙烯

压力范围: 0 ... 10 bar

温度范围: -10 ... +60 °C

尺寸和订货数据

接口 D1	公称通径 [mm]	气管内径	B1	H1	H2	L1	L2	L3	≈C1	≈C2	订货号	型号	PU*
压铸锌结构													
M5	2.4	3	10	21.1	16.1	17.2	3.8	5.2	7	8	4 468	LCK-M5-PK-3	10
	2.4	4	11	21.1	16.1	18	3.8	5.6	7	8	4 562	LCK-M5-PK-4	10
G1/8	2	3	16	27.1	19.1	21.1	4.9	6.1	13	8	4 136	LCK-1/8-PK-3	10
	2.9	4	16	30.2	22.2	27.1	4.9	9.1	13	12	4 469	LCK-1/8-PK-4	10
	4.9	6	16	30.3	22.3	27.1	4.9	9.1	13	14	4 470	LCK-1/8-PK-6	10
G1/4	2.9	4	20	34.2	24.2	28.1	5.7	9.2	17	12	4 471	LCK-1/4-PK-4	10
	4.9	6	20	34.3	24.3	28.1	5.5	9.3	17	14	4 472	LCK-1/4-PK-6	10
	8	9	20	37.6	27.6	33.3	5.7	11.8	17	19	11 452	LCK-1/4-PK-9	10
G3/8	4.9	6	25	39.3	26.8	30.3	6.7	9.3	22	14	4 473	LCK-3/8-PK-6	1
	8	9	25	42.6	30.1	35.3	6.7	11.8	22	19	4 474	LCK-3/8-PK-9	1
G1/2	11.7	13	30	49.2	34.2	46.6	7.9	16.85	27	24	4 100	LCK-1/2-PK-13	1
塑料结构													
G1/8	3.4	4	16	30.5	22.5	27.5	7.1	8.25	13	12	6 259	LCK-1/8-PK-4-KU	10
	5.3	6	16	30.5	22.5	27.5	7.1	8.25	13	14	6 260	LCK-1/8-PK-6-KU	10
G1/4	3.4	4	20	34.5	24.5	28.5	8.1	8.25	17	12	6 261	LCK-1/4-PK-4-KU	10
	5.3	6	20	34.5	24.5	28.5	8.1	8.25	17	14	6 262	LCK-1/4-PK-6-KU	10

* 包装单位数量

L形快拧接头 LCKN

技术参数

FESTO

L形快拧接头 LCKN

可旋转，带密封圈 OL...

材料:

压铸锌/铝，带密封圈

压力范围: -0.9 ... 16 bar

温度范围: -20 ... +80 °C

注意: 不能用作旋转分气接头。

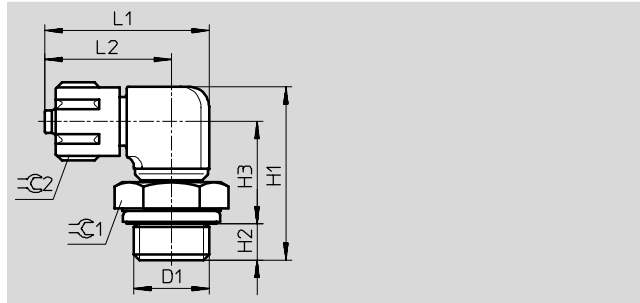

尺寸和订货数据												
接口 D1	公称通径 [mm]	气管内径	H1	H2	H3	L1	L2	≈C1	≈C2	订货号	型号	PU*
M5	1.7	3	22.2	3.55	15.15	20.1	16.1	7	8	164 995	LCKN-M5-PK-3	10
	2.6	4	24.3	3.55	15.75	23.2	19.2	7	-	164 996	LCKN-M5-PK-4	10
G1/8	1.7	3	24.6	4.7	15.9	25.4	18.9	13	8	164 997	LCKN-1/8-PK-3	10
	2.6	4	27	4.7	16.3	28.5	22	13	12	164 998	LCKN-1/8-PK-4	10
	4.6	6	30.3	4.7	18.6	28.6	22.1	13	14	164 999	LCKN-1/8-PK-6	10
G1/4	2.6	4	29.5	5.8	17.7	28.5	22	17	12	165 000	LCKN-1/4-PK-4	10
	4.6	6	32.8	5.8	20.0	28.6	22.1	17	14	165 001	LCKN-1/4-PK-6	10
G3/8	4.6	6	33.8	6.0	20.8	28.6	22.1	19	14	165 002	LCKN-3/8-PK-6	1

* 包装单位数量

T形快拧接头 TCK

技术参数

FESTO

T形快拧接头 TCK

可旋转

材料:

压铸锌, 带 2 个密封圈
螺纹 G $\frac{3}{8}$ 和 G $\frac{1}{2}$: 蓝色阳极氧化铝
不含铜和聚四氟乙烯

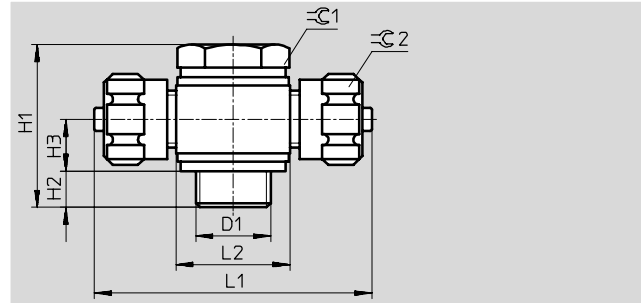

T形快拧接头

TCK-...-KU

可旋转, 带圈

材料:

聚醋酸酯
不含铜和聚四氟乙烯

压力范围: 0 ... 10 bar

温度范围: -10 ... +60 °C

尺寸和订货数据

接口 D1	公称通径 [mm]	气管内径	H1	H2	H3	L1	L2	⊙C1	⊙C2	订货号	型号	PU*
压铸锌结构												
M5	2	3	17.2	3.8	5.2	32.2	10	7	8	4 484	TCK-M5-PK-3	10
	2	4	18	3.8	5.6	39.4	11	7	8	4 563	TCK-M5-PK-4	10
G $\frac{1}{8}$	2	3	21.1	4.9	6.1	38.2	16	13	8	4 137	TCK- $\frac{1}{8}$ -PK-3	10
	2.9	4	27.1	4.9	9.1	44.4	16	13	12	4 485	TCK- $\frac{1}{8}$ -PK-4	10
	4.9	6	27.1	4.9	9.1	44.6	16	13	14	4 486	TCK- $\frac{1}{8}$ -PK-6	10
G $\frac{1}{4}$	2.9	4	28.1	5.7	9.2	48.4	20	17	12	4 487	TCK- $\frac{1}{4}$ -PK-4	10
	4.9	6	28.1	5.5	9.3	48.6	20	17	14	4 488	TCK- $\frac{1}{4}$ -PK-6	10
铝制结构												
G $\frac{3}{8}$	4.9	6	30.3	6.7	9.3	53.6	25	22	14	4 489	TCK- $\frac{3}{8}$ -PK-6	1
	8	9	35.3	6.7	11.8	60.2	25	22	14	4 490	TCK- $\frac{3}{8}$ -PK-9	1
G $\frac{1}{2}$	11.7	13	46.6	7.9	16.9	68.4	30	27	24	4 101	TCK- $\frac{1}{2}$ -PK-13	1
塑料结构												
G $\frac{1}{8}$	3.4	4	27.5	7.1	8.25	45	16	13	12	6 263	TCK- $\frac{1}{8}$ -PK-4-KU	10
	5.3	6	27.5	7.1	8.25	45	16	13	14	6 264	TCK- $\frac{1}{8}$ -PK-6-KU	10
G $\frac{1}{4}$	3.4	4	28.5	8.1	8.25	49	20	17	12	6 265	TCK- $\frac{1}{4}$ -PK-4-KU	10
	5.3	6	28.5	8.1	8.25	49	20	17	14	6 266	TCK- $\frac{1}{4}$ -PK-6-KU	10

* 包装单位数量

T形快拧接头 FCK

技术参数

FESTO

T形快拧接头 FCK-...-KU

材料:
塑料
不含铜和聚四氟乙烯
符合RoHS规定

压力范围: 0 ... 10 bar
温度范围: -10 ... +60 °C

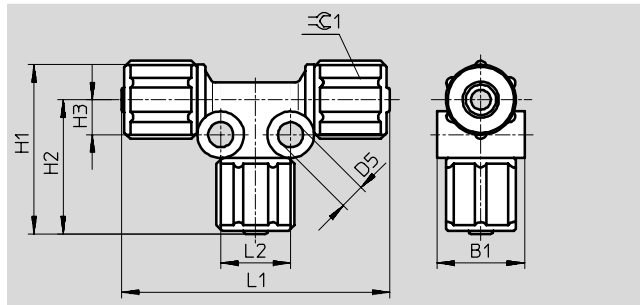

尺寸和订货数据													
气管内径	公称通径 [mm]	B1	D5	H1	H2	H3	L1	L2	$\approx \varnothing 1$	订货号	型号	PU*	
3	2.4	11	4.3	23.8	19.8	5	39.6	10	8	6 273	FCK-3-PK-3-KU	10	
4	3.4	15	4.3	30.2	24.2	6	48.4	12	12	6 274	FCK-3-PK-4-KU	10	
6	5.3	18	4.3	31.2	24.2	6	48.4	12	14	6 275	FCK-3-PK-6-KU	10	
9	8	22	4.3	38.3	28.8	7.1	56.4	13	19	6 276	FCK-3-PK-9-KU	10	

* 包装单位数量

锁定螺母 MCK

技术参数

锁定螺母 MCK

用于气管接头

材料:

蓝色阳极氧化铝
不含铜和聚四氟乙烯
符合RoHS规定

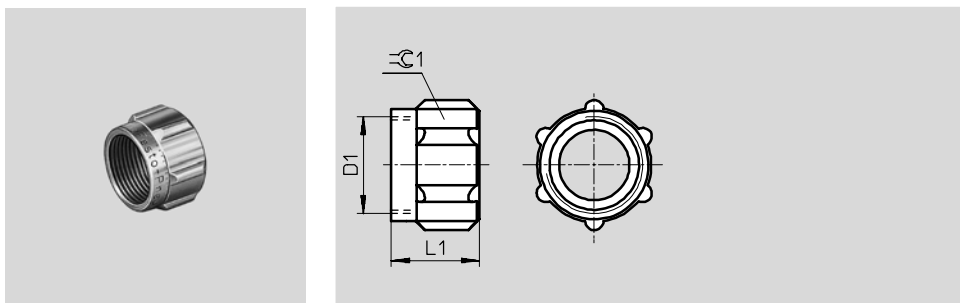

锁定螺母 MCK-...-KU

用于气管接头

材料:

塑料结构
不含铜和聚四氟乙烯
符合RoHS规定

尺寸和订货数据

气管内径	D1	L1	≈C1	订货号	型号	PU*
铝制结构						
3	M6x0.75	8.5	8	205 254	MCK-PK-3	1
4	M10x1	11	12	2 965	MCK-PK-4 ¹⁾	1
4	M8x1	9.5	-	205 257	MCK-PK-4-R ²⁾	1
6	M12x1	11	14	2 966	MCK-PK-6	1
9	M16x1	14.4	19	2 967	MCK-PK-9	1
13	M22x1	18	24	206 504	MCK-PK-13	1
塑料结构						
3	M6x0.75	9.5	8	211 289	MCK-PK-3-KU	1
4	M10x1	12.5	12	211 291	MCK-PK-4-KU ¹⁾	1
6	M12x1	12.5	14	211 292	MCK-PK-6-KU	1
9	M16x1	16	19	211 293	MCK-PK-9-KU	1

* 包装单位数量

- 1) 除接头 CK-M5-PK-4, LCK-M5-PK-4, TCK-M5-PK-4
- 2) 用于接头 CK-M5-PK-4, LCK-M5-PK-4, TCK-M5-PK-4

中空复合分气接头

技术参数

FESTO

中空螺栓 VT, 带 环形管接头 LK (一个排气口)

材料:

中空螺栓: 镀锌钢

环形管接头 LK: 压铸锌

环形管接头 LK-...-KU: 塑料

不含铜和聚四氟乙烯

认证:

环形管接头 LK: 德国劳氏

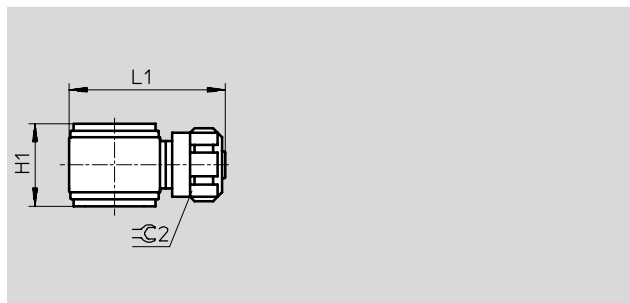

订货数据				尺寸 → 18			
中空螺栓		环形管接头					
气接口	环形管接头数量	订货号	型号	气接口	订货号	型号	PU*
压铸锌结构							
M5	2	206 145	VT-M5-2 ³⁾	用于3 mm气管	4 475	LK-M5-PK-3 ¹⁾	10
	3	4 594	VT-M5-3 ³⁾				
G1/8	2	4 593	VT-1/8-2-PK-3 ³⁾	用于3 mm气管	4 597	LK-1/8-PK-3 ¹⁾	10
	3	4 595	VT-1/8-3-PK-3				
G1/8	2	206 146	VT-1/8-2 ³⁾	用于4 mm气管	4 476	LK-1/8-PK-4 ¹⁾	10
	3	4 596	VT-1/8-3 ³⁾				
G1/8	2	206 146	VT-1/8-2 ³⁾	用于6 mm气管	4 477	LK-1/8-PK-6 ¹⁾	10
	3	4 596	VT-1/8-3 ³⁾				
G1/4	2	206 147	VT-1/4-2 ³⁾	用于4 mm气管	4 478	LK-1/4-PK-4 ¹⁾	10
	3	2 335	VT-1/4-3 ³⁾				
G1/4	2	206 147	VT-1/4-2 ³⁾	用于6 mm气管	4 479	LK-1/4-PK-6 ¹⁾	10
	3	2 335	VT-1/4-3 ³⁾				
G3/8	2	206 148	VT-3/8-2 ³⁾	用于6 mm气管	4 480	LK-3/8-PK-6 ¹⁾	1
	3	2 336	VT-3/8-3 ³⁾				
塑料结构							
G1/8	2	206 146	VT-1/8-2 ³⁾	用于4 mm气管	6 280	LK-1/8-PK-4-KU ^{2) 3)}	10
	3	4 596	VT-1/8-3 ³⁾				
G1/8	2	206 146	VT-1/8-2 ³⁾	用于6 mm气管	6 281	LK-1/8-PK-6-KU ^{2) 3)}	10
	3	4 596	VT-1/8-3 ³⁾				
G1/4	2	206 147	VT-1/4-2 ³⁾	用于4 mm气管	6 282	LK-1/4-PK-4-KU ^{2) 3)}	10
	3	2 335	VT-1/4-3 ³⁾				
G1/4	2	206 147	VT-1/4-2 ³⁾	用于6 mm气管	6 283	LK-1/4-PK-6-KU ^{2) 3)}	10
	3	2 335	VT-1/4-3 ³⁾				

* 包装单位数量

1) 带2个密封圈

2) 带模塑密封圈, 压力范围 0...10 bar, 温度范围 -10...+60 °C

3) 符合RoHS规定

中空复合分气接头

技术参数

FESTO

中空螺栓 VT, 带环形管接头TK
(2个排气口)

材料:

中空螺栓: 镀锌钢

环形管接头 TK: 压铸锌

环形管接头 TK...-KU: 塑料

不含铜和聚四氟乙烯

认证:

环形管接头 TK: 德国劳氏

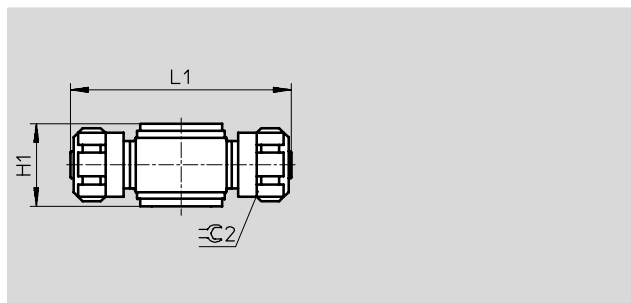

订货数据				尺寸 → 18			
中空螺栓		环形管接头					
气接口	气管	订货号	型号	气接口	订货号	型号	PU*
压铸锌结构							
M5	2	206 145	VT-M5-2 ³⁾	用于3 mm气管	4 491	TK-M5-PK-3 ¹⁾	10
	3	4 594	VT-M5-3 ³⁾		4 598	TK-1/8-PK-3 ¹⁾	
G1/8	2	4 593	VT-1/8-2-PK-3 ³⁾	用于3 mm气管			10
	3	4 595	VT-1/8-3-PK-3				
	2	206 146	VT-1/8-2 ³⁾	用于4 mm气管	4 492	TK-1/8-PK-4 ¹⁾	10
	3	4 596	VT-1/8-3 ³⁾				
	2	206 146	VT-1/8-2 ³⁾		用于6 mm气管	4 493	
3	4 596	VT-1/8-3 ³⁾					
G1/4	2	206 147	VT-1/4-2 ³⁾	用于4 mm气管	4 494	TK-1/4-PK-4 ¹⁾	10
	3	2 335	VT-1/4-3 ³⁾				
	2	206 147	VT-1/4-2 ³⁾	用于6 mm气管	4 495	TK-1/4-PK-6 ¹⁾	10
	3	2 335	VT-1/4-3 ³⁾				
G3/8	2	206 148	VT-3/8-2 ³⁾		4 496	TK-3/8-PK-6 ¹⁾	1
塑料结构							
G1/8	2	206 146	VT-1/8-2 ³⁾	用于4 mm气管	6 284 TK-1/8-PK-4-KU ^{2) 3)}		10
	3	4 596	VT-1/8-3 ³⁾				
	2	206 146	VT-1/8-2 ³⁾	用于6 mm气管	6 285 TK-1/8-PK-6-KU ^{2) 3)}		10
	3	4 596	VT-1/8-3 ³⁾				
G1/4	2	206 147	VT-1/4-2 ³⁾	用于4 mm气管	6 286 TK-1/4-PK-4-KU ^{2) 3)}		10
	3	2 335	VT-1/4-3 ³⁾				
	2	206 147	VT-1/4-2 ³⁾	用于6 mm气管	6 287 TK-1/4-PK-6-KU ^{2) 3)}		10
	3	2 335	VT-1/4-3 ³⁾				

* 包装单位数量

1) 带2个密封圈

2) 带模塑密封圈。压力范围 0...10 bar。温度范围 -10...+60 °C

3) 符合RoHS规定

中空复合分气接头

技术参数

中空复合分气接头

组成包括:

- 中空螺栓 VT 和 环形管接头 LK
→ 16

or

- 中空螺栓 VT 和 环形管接头 TK
→ 17

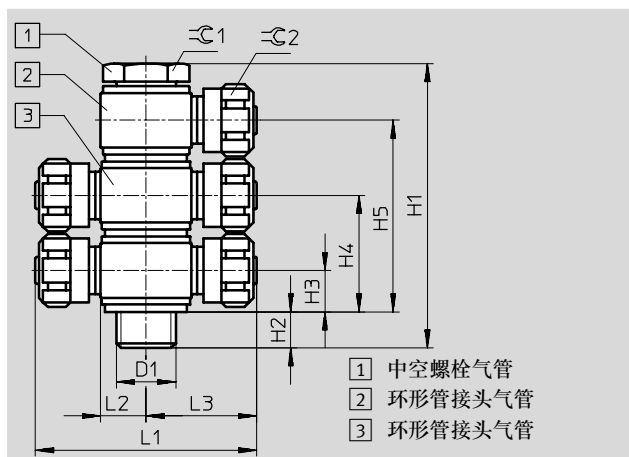

尺寸														
接口 D1	中空螺栓 型号	环形管接头 型号	H1	H2	H3	H4	H5	L1	L2	L3	≈C1	≈C2		
M5	VT-M5-2	LK-M5-PK-3	27.3	4	5.2	15.1	-	-	5	16.1	7	8		
		TK-M5-PK-3							32.2					
	VT-M5-3	LK-M5-PK-3	37.1	3.9	5.2	15.1	25	-	5	16.1	7	8		
		TK-M5-PK-3							32.2					
G1/8	VT-1/8-2-PK-3	LK-1/8-PK-3	31.8	5	6.1	16.7	-	-	8	19.1	13	8		
		TK-1/8-PK-3							38.2					
	VT-1/8-3-PK-3	LK-1/8-PK-3	42.4	5	6.1	16.7	27.3	-	8	19.1	13	8		
		TK-1/8-PK-3							38.2					
	VT-1/8-2	LK-1/8-PK-4	44	5.2	9.1	25.7	-	-	8	22.2	13	12		
		TK-1/8-PK-4							44.4					
		LK-1/8-PK-6							8				22.3	14
		TK-1/8-PK-6							44.6					
	VT-1/8-3	LK-1/8-PK-4	60.8	5.4	9.1	25.7	42.3	-	8	22.2	13	12		
		TK-1/8-PK-4							44.4					
		LK-1/8-PK-6							8				22.3	14
		TK-1/8-PK-6							44.6					
G1/4	VT-1/4-2	LK-1/4-PK-4	44.7	6.1	9.2	25.4	-	-	10	24.2	17	12		
		TK-1/4-PK-4							48.4					
		LK-1/4-PK-6		5.7	9.3	25.7			10			24.3	14	
		TK-1/4-PK-6		48.6										
	VT-1/4-3	LK-1/4-PK-4	61.9	6.1	9.2	25.4	41.6	-	-	10	24.2	17	12	
		TK-1/4-PK-4								48.4				
		LK-1/4-PK-6		5.5	9.3	25.7	42.1			10			24.3	14
		TK-1/4-PK-6		48.6										
G3/8	VT-3/8-2	LK-3/8-PK-6	46.9	6.9	9.3	25.7	-	-	12.5	26.8	22	14		
		TK-3/8-PK-6							53.6					
	VT-3/8-3	LK-3/8-PK-6	63.1	6.7	9.3	25.7	42.1	-	-	12.5	26.8	22	14	
		TK-3/8-PK-6								53.6				

快拧接头ACX/CX, 金属编织软管

技术参数

快拧接头 ACX

内螺纹, 带密封圈, 用于金属编织软管 PX

材料:
阳极氧化铝

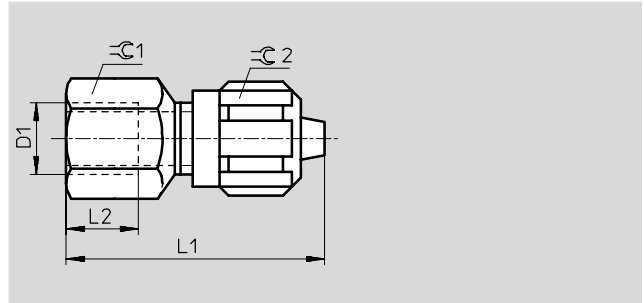

尺寸和订货数据									
接口 D1	公称通径 [mm]	气管内径	L1	L2	≈C1	≈C2	订货号	型号	PU*
G1/8	3.5	4	35	10	13	12	4 032	ACX-1/8-PX-4	1
G1/4	5	6	43	12	17	14	4 033	ACX-1/4-PX-6	1
G3/8	8	9	54	15	22	19	4 034	ACX-3/8-PX-9	1

* 包装单位数量

快拧接头 CX

外螺纹, 带密封圈, 用于金属编织软管 PX

材料:
阳极氧化铝

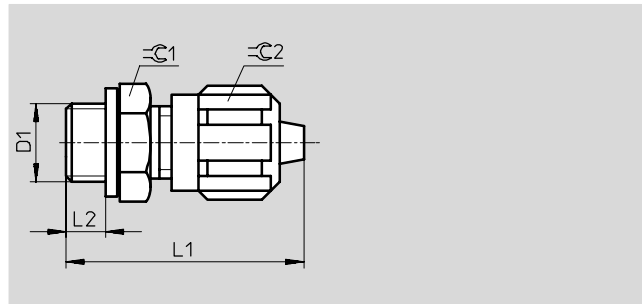

尺寸和订货数据									
接口 D1	公称通径 [mm]	气管内径	L1	L2	≈C1	≈C2	订货号	型号	PU*
G1/8	3.5	4	31.5	4.9	13	12	4 035	CX-1/8-PX-4	10
	5	6	36.5	4.9	13	14	4 453	CX-1/8-PX-6	10
G1/4	3.5	4	34	5.8	17	12	4 454	CX-1/4-PX-4	10
	5	6	39	5.8	17	14	4 036	CX-1/4-PX-6	10
G3/8	8	9	47	6.8	22	19	4 037	CX-3/8-PX-9	1

* 包装单位数量

快拧接头LCX/LCX, 金属编织软管

技术参数

FESTO

L形快拧接头 LCX

可旋转, 带2个密封圈, 用于金属编织软管 PX

材料:
阳极氧化铝

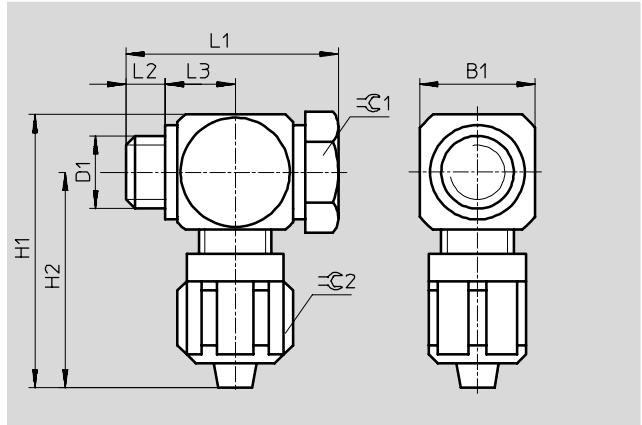

尺寸和订货数据													
接口 D1	公称通径 [mm]	气管内径	B1	L1	L2	L3	H1	H2	≈C1	≈C2	订货号	型号	PU*
G1/8	3.5	4	16	27.1	4.7	9.2	39.5	31.5	13	14	4 041	LCX-1/8-PX-4	1
G1/4	5	6	20	34.3	5.7	11.8	46	36	17	17	4 042	LCX-1/4-PX-6	1
G3/8	8	9	25	41.3	6.7	14.3	58	45.5	22	22	4 043	LCX-3/8-PX-9	1

包装单位数量

T形快拧接头 TCX

可旋转, 带2个密封圈, 用于金属编织软管 PX

材料:
阳极氧化铝

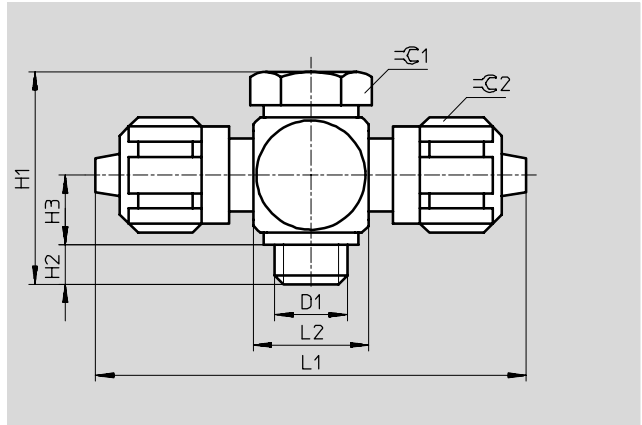

尺寸和订货数据													
接口 D1	公称通径 [mm]	气管内径	H1	H2	H3	L1	L2	≈C1	≈C2	订货号	型号	PU*	
G1/8	3.5	4	27.1	4.7	9.2	63	16	13	14	4 044	TCX-1/8-PX-4	1	
G1/4	5	6	34.3	5.7	11.8	72	20	17	17	4 045	TCX-1/4-PX-6	1	
G3/8	8	9	41.3	6.7	14.3	91	25	22	22	4 046	TCX-3/8-PX-9	1	

包装单位数量