

## Pressure booster DPA

**FESTO**

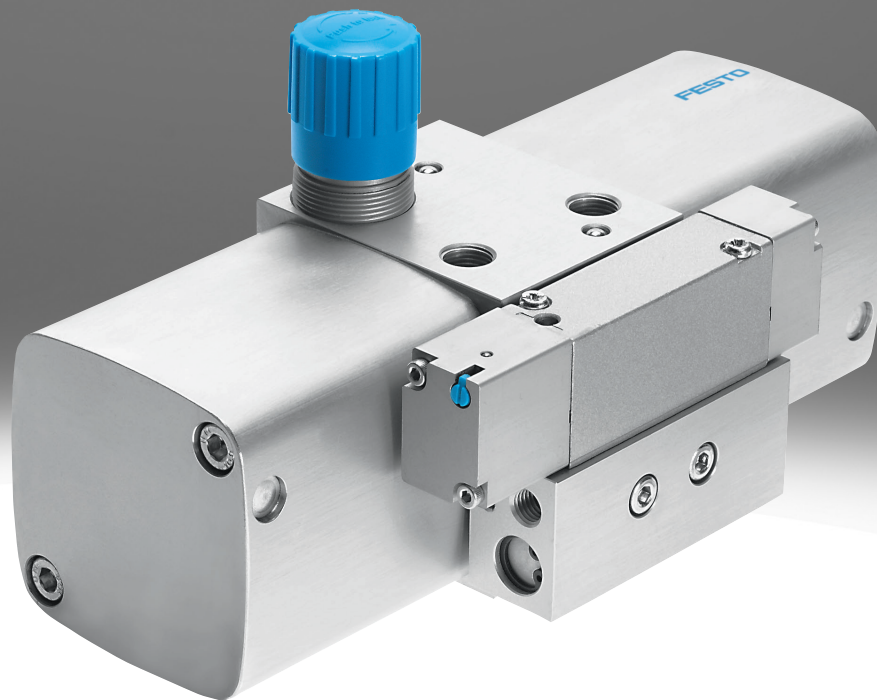

## Characteristics

### At a glance

The pressure booster is a twin-piston pressure intensifier used only for compressing air. When the DPA is pressurised with compressed air, integrated check valves automatically ensure the pressure on the secondary side is built up. The output pressure  $p_2$  can increase to up to twice the value of the input pressure  $p_1$ . The required output pressure is set using a manually operated pressure regulator. In the case of pressure boosters without a pressure regulator, the output pressure is always double the input pressure. The air supply to both drive pistons is controlled by a pneumatic directional control valve that reverses automatically when the stroke end position has been reached. The pressure booster starts up automatically when the input pressure is applied and the desired output pressure has not yet been reached. When the set output pressure is reached, the pressure booster stops operating to save energy, but restarts automatically when the output pressure drops again.

- Available as pressure booster/air pressure reservoir combinations
- Long service life
- Compact design
- Available with sensing option

Note: Pressure boosters are used for the occasional drawing-off of pressurised compressed air. Pressure boosters are not suitable as a substitute for a compressor, as wear on the seals and drive piston increases significantly when used continuously without breaks.

Note: A pressure gauge is strongly recommended to check the output pressure  $p_2$ , as the required output pressure  $p_2$  must be set. The regulator setting of the DPA-63/100 can be secured against unauthorised adjustment using the regulator lock LRVS.

### Diagrams

Link [dpa](#)



The diagrams shown in this document are also available online. These can be used to display precise values.

### Position sensing

[A] For proximity sensor

The version of the DPA with proximity sensing provides the option of sensing individual strokes of the drive piston with the help of an external sensor and adding counter.

### Air reservoir

[ ] Without

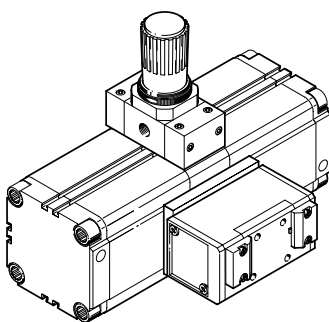

[CRVZS] Stainless steel

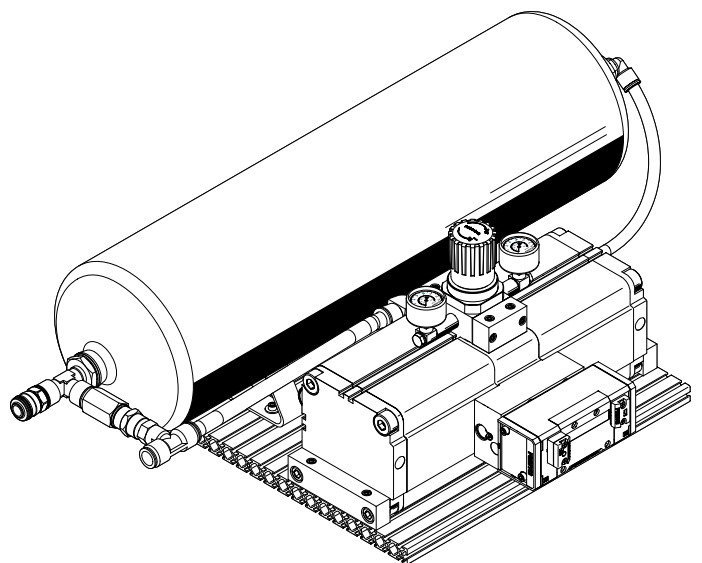

Combination of pressure booster, air reservoir in stainless steel, bypass with check valve for constant filling of the air reservoir with the system pressure, pressure gauge set, silencer, fitting and quick coupling. Combination completely mounted on a profile plate.

## Type code

001	Series
DPA	Pressure booster

002	Size [mm]
40	40
63	63
100	100

003	Outlet pressure
10	Max. 10 bar
16	Max. 16 bar
D	Double input pressure, without pressure regulator

004	Position sensing
	None
A	For proximity sensor

005	Air reservoir
CRVZS	Stainless steel
	Without

006	Air reservoir volume
	Without
2	2 l
5	5 l
10	10 l
20	20 l

## Datasheet

### General technical data – Pressure booster DPA

Piston diameter	40 mm	63 mm	100 mm
Pneumatic connection, port 1	G1/4	G3/8	G1/2
Pneumatic connection, port 2	G1/4	G3/8	G1/2
Pneumatic connection, port 3	M7	G3/8	G1/2
Design <sup>1)</sup>	Twin-piston pressure booster	Twin-piston pressure booster, With piston magnet	
Type of mounting	Via female thread		
Mounting position	optional		
Pressure gauge (ANALOG) or Pressure display (DIGITAL) <sup>2)</sup>	Prepared for G1/8		Prepared for G1/4, Prepared for G1/8

1) With piston magnet for pressure booster with sensing option

2) For piston Ø 100 mm and DPA without pressure regulator: thread G1/8

### General technical data – Pressure booster DPA with compressed air reservoir

Piston diameter	40 mm	63 mm	100 mm	
Volume	2 l	5 l	10 l	20 l
Pneumatic connection, port 1	QS-10		QS-12	QS-16
Pneumatic connection, port 2	KD4			
Pneumatic connection, port 3	Silencer			
Design	Twin-piston pressure booster, With air reservoir, Via pressure gauge, With check valve			
Type of mounting	Via slot nuts			
Mounting position	optional	Condensate drain underneath		
Pressure gauge (ANALOG) or Pressure display (DIGITAL)	With pressure gauge			
Max. tightening torque for condensate drain	–	27 Nm		

### Function – pressure booster without pressure regulator

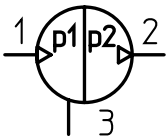

### Function – pressure booster with pressure regulator

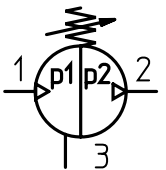

## Datasheet

Operating and environmental conditions – pressure booster DPA							
Piston diameter	40 mm			63 mm		100 mm	
Output pressure 2	5 ... 16 bar	4.5 ... 10 bar	4.5 ... 16 bar	4 ... 16 bar	4 ... 10 bar	4 ... 16 bar	4 ... 10 bar
Operating pressure	0.2 ... 0.8 MPa	0.25 ... 0.8 MPa	0.25 ... 1 MPa	0.2 ... 1 MPa	0.2 ... 0.8 MPa	0.2 ... 1 MPa	0.2 ... 0.8 MPa
Operating pressure	2 ... 8 bar	2.5 ... 8 bar	2.5 ... 10 bar	2 ... 10 bar	2 ... 8 bar	2 ... 10 bar	2 ... 8 bar
Operating pressure	29 ... 116 psi	36.25 ... 116 psi	36.25 ... 145 psi	29 ... 145 psi	29 ... 116 psi	29 ... 145 psi	29 ... 116 psi
Inlet pressure 1	0.25 ... 0.8 MPa		0.25 ... 1 MPa	0.2 ... 1 MPa	0.2 ... 0.8 MPa	0.2 ... 1 MPa	0.2 ... 0.8 MPa
Inlet pressure 1	2.5 ... 8 bar		2.5 ... 10 bar	2 ... 10 bar	2 ... 8 bar	2 ... 10 bar	2 ... 8 bar
Inlet pressure 1	36.25 ... 116 psi		36.25 ... 145 psi	29 ... 145 psi	29 ... 116 psi	29 ... 145 psi	29 ... 116 psi
Output pressure 2	0.5 ... 1.6 MPa	0.45 ... 1 MPa	0.45 ... 1.6 MPa	0.4 ... 1.6 MPa	0.4 ... 1 MPa	0.4 ... 1.6 MPa	0.4 ... 1 MPa
Output pressure 2	72.5 ... 232 psi	65.25 ... 145 psi	65.25 ... 232 psi	58 ... 232 psi	58 ... 145 psi	58 ... 232 psi	58 ... 145 psi
Pressure regulation range	0.4 ... 1.6 MPa	0.45 ... 1 MPa	0.45 ... 1.6 MPa	0.4 ... 1.6 MPa	0.4 ... 1 MPa	0.4 ... 1.6 MPa	0.4 ... 1 MPa
Pressure regulation range	4 ... 16 bar	4.5 ... 10 bar	4.5 ... 16 bar	4 ... 16 bar	4 ... 10 bar	4 ... 16 bar	4 ... 10 bar
Pressure regulation range	58 ... 232 psi	65.25 ... 145 psi	65.25 ... 232 psi	58 ... 232 psi	58 ... 145 psi	58 ... 232 psi	58 ... 145 psi
Note on pressure regulation range	–	If the controller spring is tensioned to the maximum, the maximum output pressure can be exceeded by 40%.					
Operating medium <sup>1)</sup>	Compressed air to ISO 8573-1:2010 [7:3:4]						
Note on operating and pilot medium	Lubricated operation not possible						
Ambient temperature	5 ... 60°C						
Storage temperature	5 ... 60°C						
Corrosion resistance class CRC <sup>2)</sup>	2 - Moderate corrosion stress						

1) A higher pressure dew point of max. +3 °C is possible if the minimum operating temperature is always at least 8 K higher than the pressure dew point, so that there is no condensation in the pressure booster → see diagram (minimum permissible operating temperature t as a function of the pressure dew point and the pressure amplification p).

2) More information visit [www.festo.com/x/topic/kbk](http://www.festo.com/x/topic/kbk)

Operating and environmental conditions – pressure booster DPA with compressed air reservoir				
Piston diameter	40 mm		63 mm	100 mm
Volume	2 l	5 l	10 l	20 l
Operating pressure	0.25 ... 0.8 MPa		0.2 ... 0.8 MPa	
Operating pressure	2.5 ... 8 bar		2 ... 8 bar	
Operating pressure	36.25 ... 116 psi		29 ... 116 psi	
Inlet pressure 1	0.2 ... 0.8 MPa			
Inlet pressure 1	2 ... 8 bar			
Inlet pressure 1	29 ... 116 psi			
Output pressure 2	0.45 ... 1.6 MPa		0.4 ... 1.6 MPa	
Output pressure 2	4.5 ... 16 bar		4 ... 16 bar	
Output pressure 2	65.25 ... 232 psi		58 ... 232 psi	
Pressure regulation range	0.45 ... 1.6 MPa		0.4 ... 1.6 MPa	
Pressure regulation range	4.5 ... 16 bar		4 ... 16 bar	
Pressure regulation range	65.25 ... 232 psi		58 ... 232 psi	
Operating medium <sup>1)</sup>	Compressed air to ISO 8573-1:2010 [7:3:4]			
Note on operating and pilot medium	Lubricated operation not possible			
Ambient temperature	5 ... 60°C			
Storage temperature	5 ... 60°C			
CE mark (see declaration of conformity) <sup>2)</sup>	–	In accordance with EU Pressure Equipment Directive		
Corrosion resistance class CRC <sup>3)</sup>	2 - Moderate corrosion stress			

1) A higher pressure dew point of max. +3 °C is possible if the minimum operating temperature is always at least 8 K higher than the pressure dew point, so that there is no condensation in the pressure booster → see diagram (minimum permissible operating temperature t as a function of the pressure dew point and the pressure amplification p).

2) More information: [www.festo.com/catalogue/dpa](http://www.festo.com/catalogue/dpa) → Support/Downloads.

3) More information visit [www.festo.com/x/topic/kbk](http://www.festo.com/x/topic/kbk)

## Datasheet

### Materials

Short type code	DPA	DPA-CRVZS
Material housing	-	
Material rotary knob	-	
Material seals	-	
Material air reservoir	-	High-alloy stainless steel
Note on materials	RoHS-compliant	
LABS (PWIS) conformity	VDMA24364-B1/B2-L	

### Minimum permissible operating temperature $t$ as a function of the pressure dew point and pressure amplification $p$

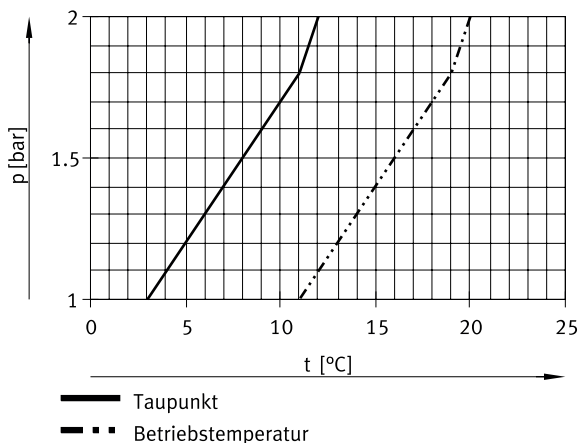

### Flow rate at input $q(\text{in})$ and flow rate at output $q(\text{out})$ as a function of output pressure $p(\text{out})$ – DPA-40

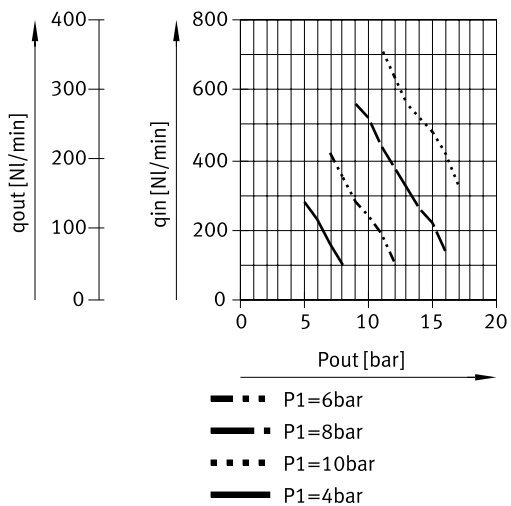

Note: Theoretical values without switching losses and friction.

## Datasheet

### Flow rate at input $q(\text{in})$ and flow rate at output $q(\text{out})$ as a function of output pressure $p(\text{out})$ – DPA-63

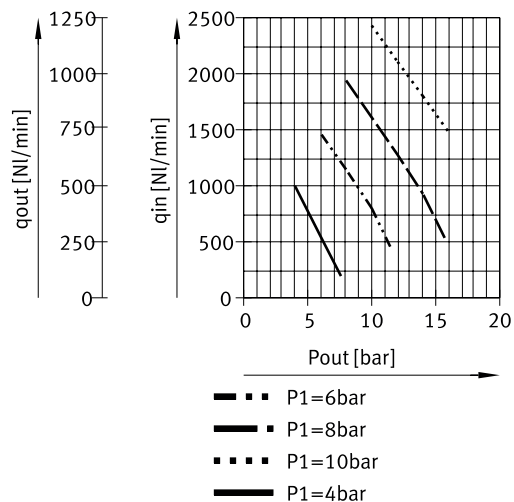

Note: Theoretical values without switching losses and friction.

### Flow rate at input $q(\text{in})$ and flow rate at output $q(\text{out})$ as a function of output pressure $p(\text{out})$ – DPA-100

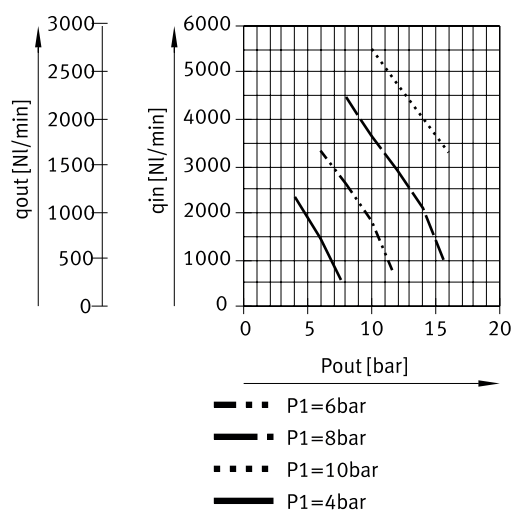

Note: Theoretical values without switching losses and friction.

## Dimensions

### Dimensions – DPA-40 without pressure regulator

Download CAD data [www.festo.com](http://www.festo.com)

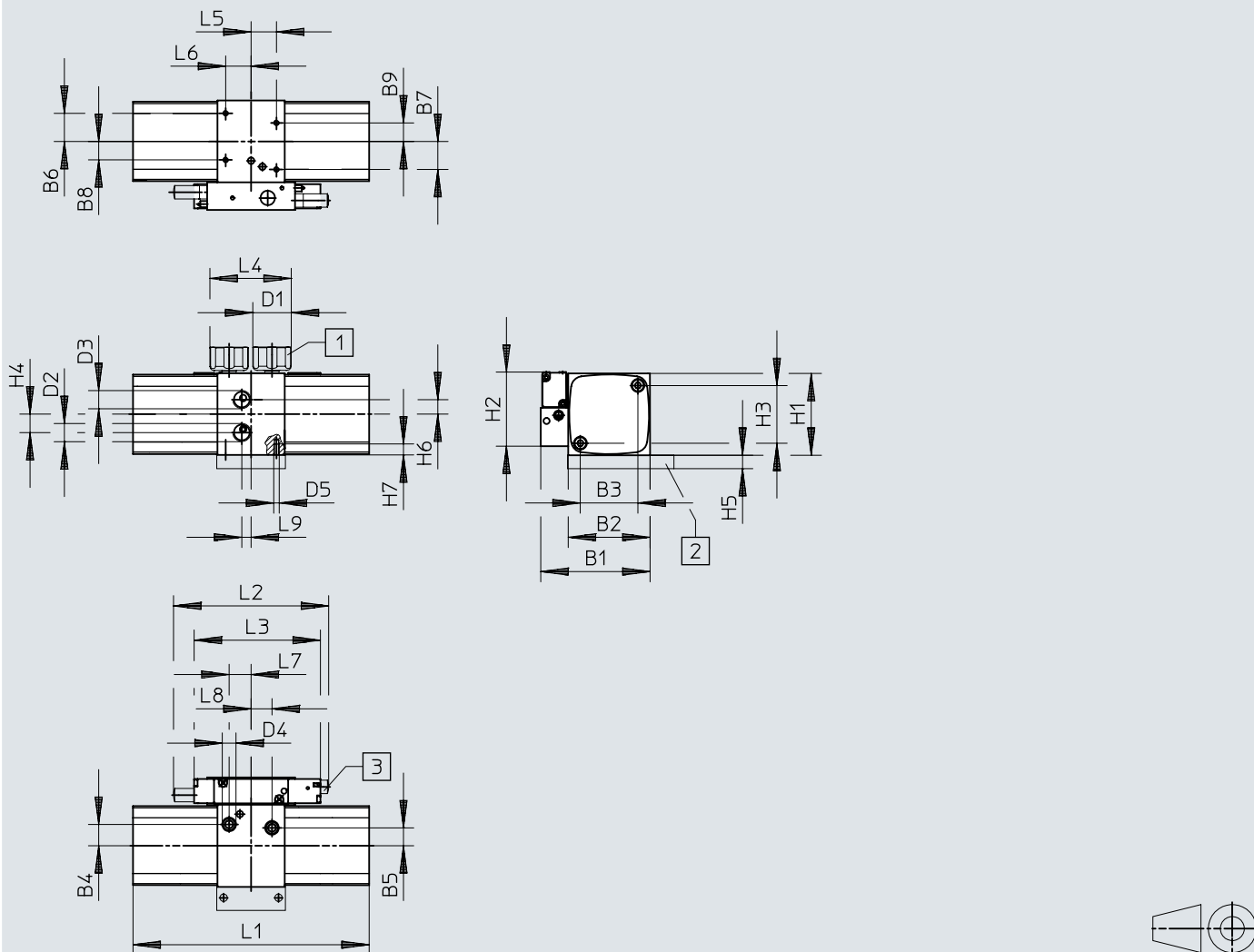

- [1] Pressure gauge kit DPA-MA-SET
- [2] Flange mounting FDPA
- [3] Silencer UC

	B1	B2	B3	B4	B5	B6	B7	B8	B9	D1	D2	D3	D4	D5
DPA-40-D	79,6	59,6	42	15,5	13	20,5	20,5	13,5	13,5	28	G1/4	G1/4	G1/8	M4

	H1	H2	H3	H4	H5	H6	H7	L1	L2	L3	L4	L5	L6	L7	L8	L9
DPA-40-D	59,6	53,9	42	13,5	10	10,5	min. 8	172	113	92	59,2	18,5	18,5	16	15,2	6,8

1) Note: This product complies with ISO 1179-1 and ISO 228-1.



## Dimensions

Dimensions – DPA-63/100-D without pressure regulator

Download CAD data [www.festo.com](http://www.festo.com)

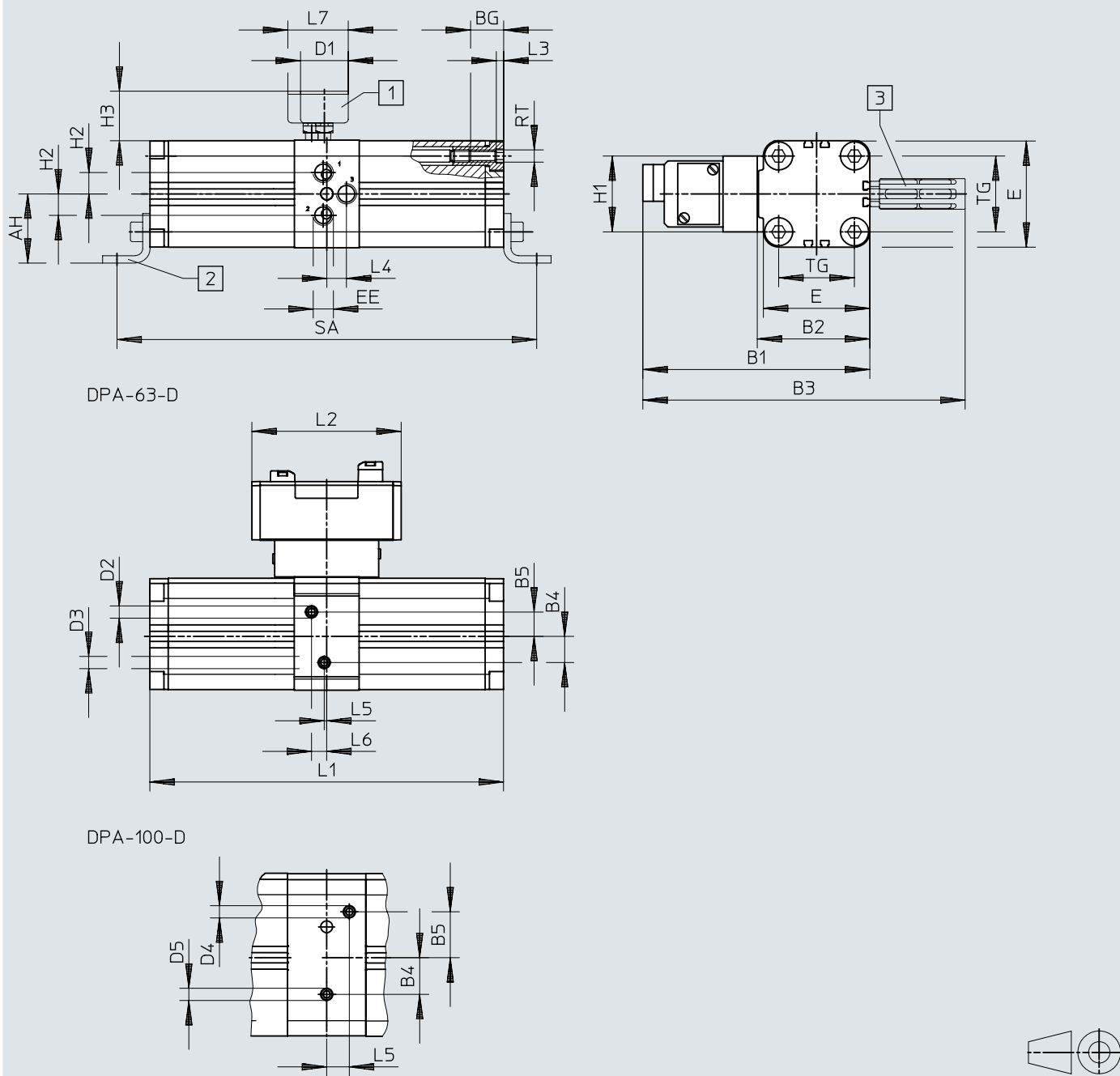

- [1] Pressure gauge MA
- [2] Foot mounting HUA
- [3] Silencer U

	AH	B1	B2	B3	B4	B5	BG	D1 ∅	E	EE	H1	H2
DPA-63	56,5	187	92,5	266	21,4	19,9	25	39	88	G3/8	62	17,5
DPA-100	81	244	133	352	30	37,5	30		128	G1/2	71	27

	H3	L1	L2	L3	L4	L5	L6	L7	RT	TG	SA
DPA-63	40,5	289	122	6	19	2	12,4	49,4	M10	62	343
DPA-100	40	367	145,5		11	18,5	–	57,5		103	433

1) Note: This product complies with ISO 1179-1 and ISO 228-1.

## Dimensions

Dimensions – DPA-40-10/16 with pressure regulator

Download CAD data [www.festo.com](http://www.festo.com)

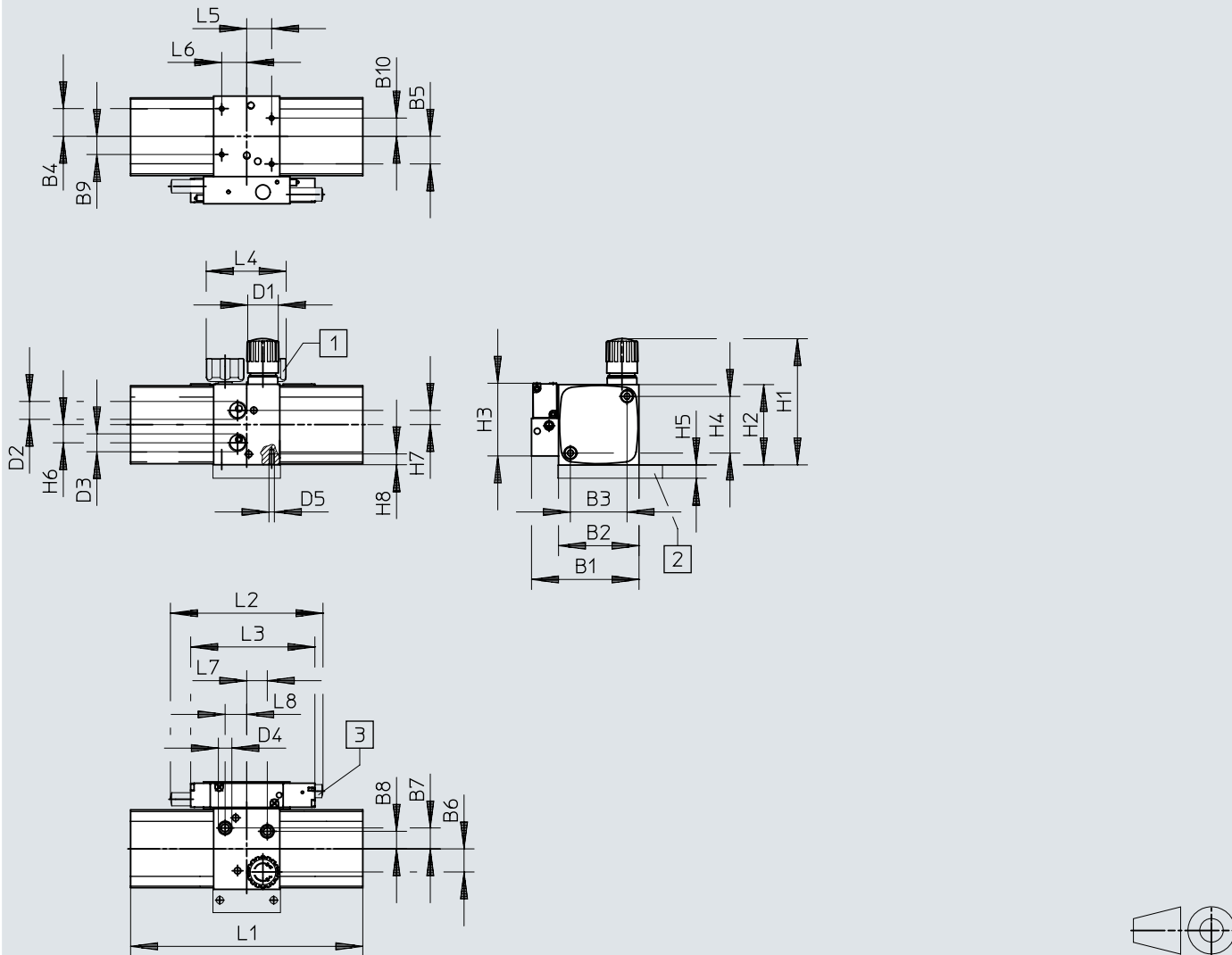

- [1] Pressure gauge kit DPA-MA-SET
- [2] Flange mounting FDPA
- [3] Silencer UC

	B1	B2	B3	B4	B5	B6	B7	B8	B9	B10	D1	D2	D3	D4	D5
DPA-40-...	79,6	59,6	42	20,5	20,5	17,5	15,5	13	13,5	13,5	22,7 ∅	G1/4	G1/4	G1/8	M4

	H1	H2	H3	H4	H5	H6	H7	H8	L1	L2	L3	L4	L5	L6	L7	L8
DPA-40-...	93,6	59,6	53,9	42	10	10,5	10,5	min. 8	172	113	92	59,2	18,5	18,5	15,2	16

1) Note: This product complies with ISO 1179-1 and ISO 228-1.

## Dimensions

Dimensions – DPA-63/100-10/16(-A) with pressure regulator

Download CAD data [www.festo.com](http://www.festo.com)

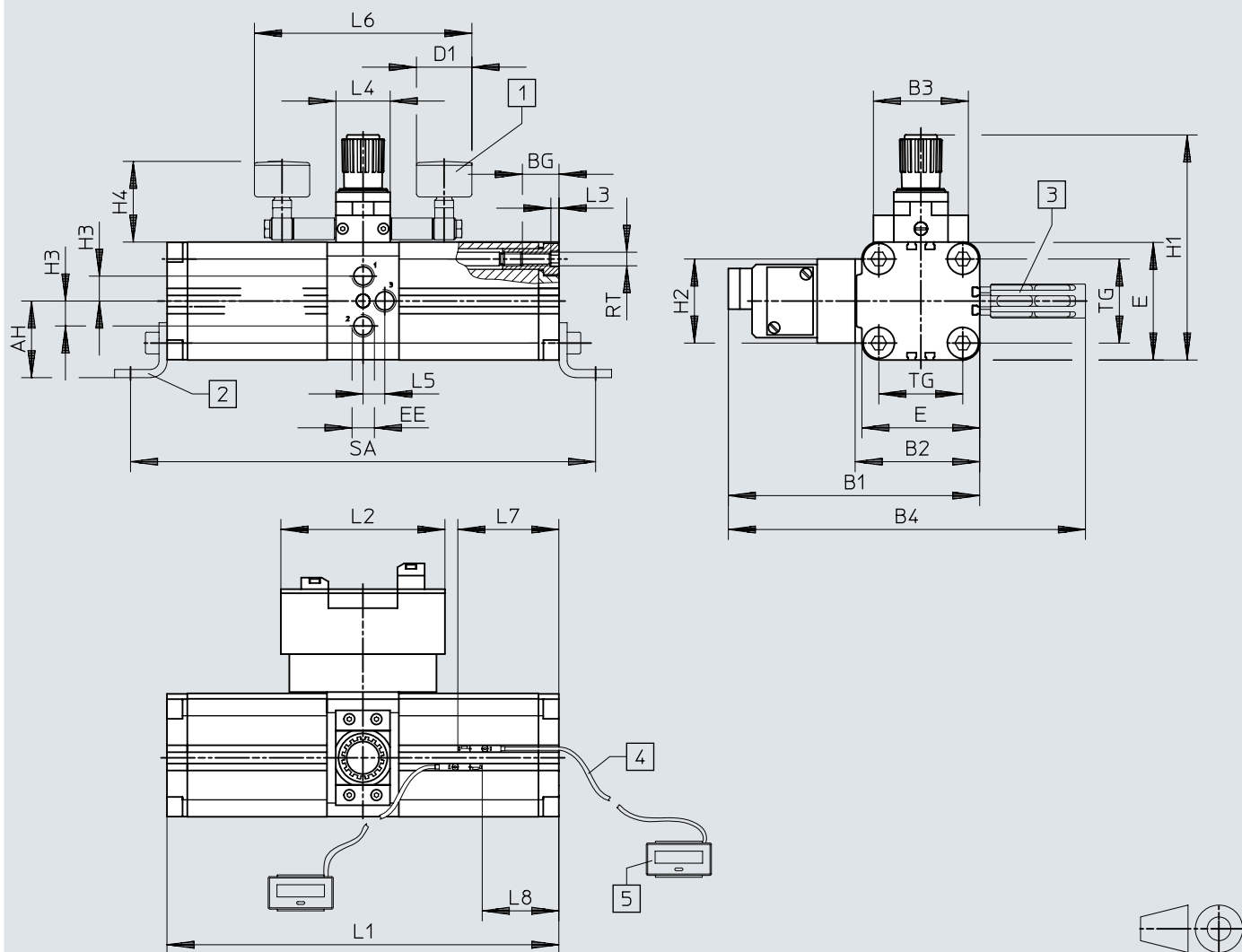

- [1] Pressure gauge kit DPA-MA-SET
- [2] Foot mounting HUA
- [3] Silencer U
- [4] Proximity switch SMT/SME
- [5] Adding counter CCES-P-C8-E

	AH	B1	B2	B3	B4	BG	D1 ∅	E	EE	H1	H2	H3
DPA-63-10/16	56,5	187	92,5	70	266	25	39	88	G3/8	169	62	17,5
DPA-100-10	81	244	133	102	352	30	39	128	G1/2	244	71	27
DPA-100-16												
	H4	L1	L2	L3	L4	L5	L6	L7	L8	RT	TG	SA
DPA-63-10/16	65	289	122	6	40	19	159	74,5	56,5	M10	62	343
DPA-100-10	75	367	145,5	6	55	11	173	93	75	M10	103	433
DPA-100-16	82,5											

1) Note: This product complies with ISO 1179-1 and ISO 228-1.

## Dimensions

Dimensions – DPA-40 with 2 l air reservoir

Download CAD data [www.festo.com](http://www.festo.com)

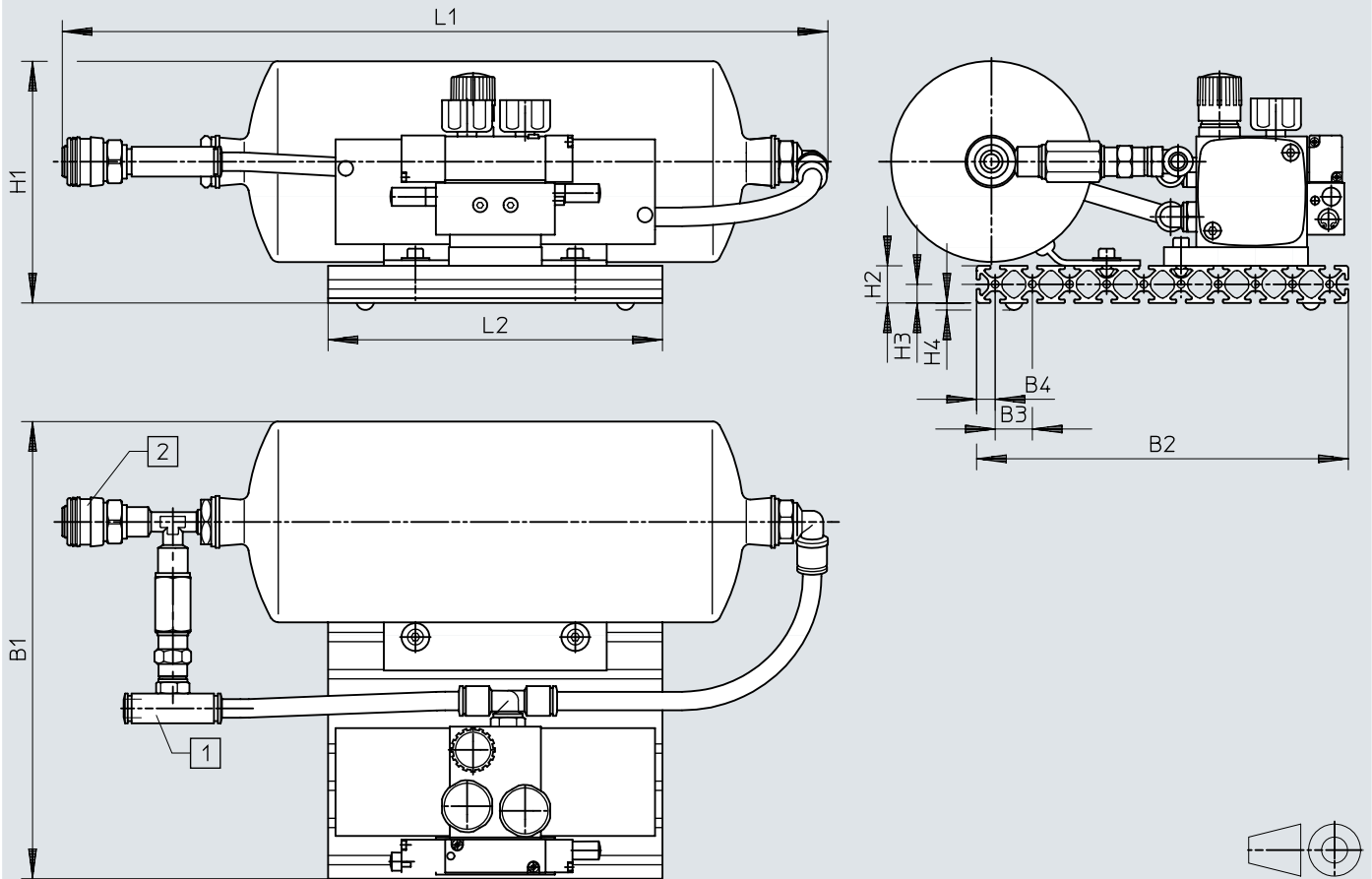

- [1] Input pressure p1, connection QS-10
- [2] Output pressure p2, connection to coupling socket KD4-1/4 with quick coupling plug KS4

	B1	B2	B3	B4	H1	H2	H3	H4	L1	L2
DPA-40-...	246	200	20	10	130	20	10	4	412	180

## Dimensions

Dimensions – DPA-40 with 5 l air reservoir

Download CAD data [www.festo.com](http://www.festo.com)

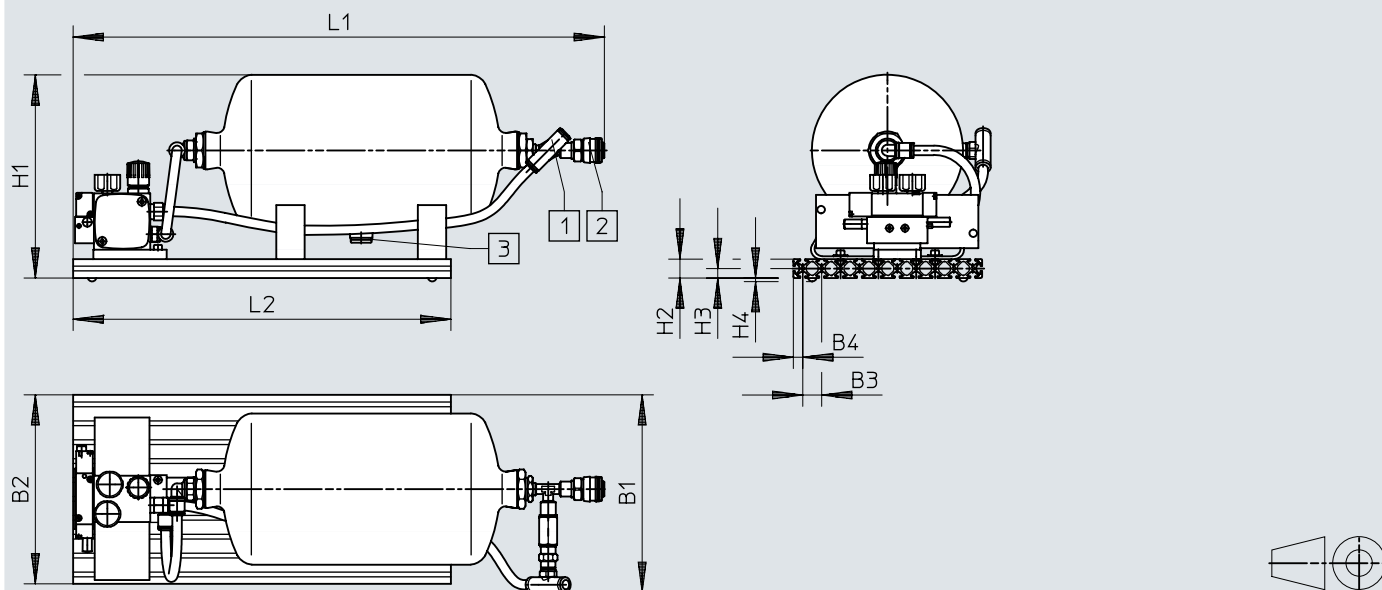

- [1] Input pressure p1, connection QS-10
- [2] Output pressure p2, connection to coupling socket KD4-1/4 with quick coupling plug KS4

	B1	B2	B3	B4	H1	H2	H3	H4	L1	L2
DPA-40-...	209	200	20	10	215	20	10	4	563	400

## Dimensions

Dimensions – DPA-63/100 with 10 l or 20 l air reservoir

Download CAD data [www.festo.com](http://www.festo.com)

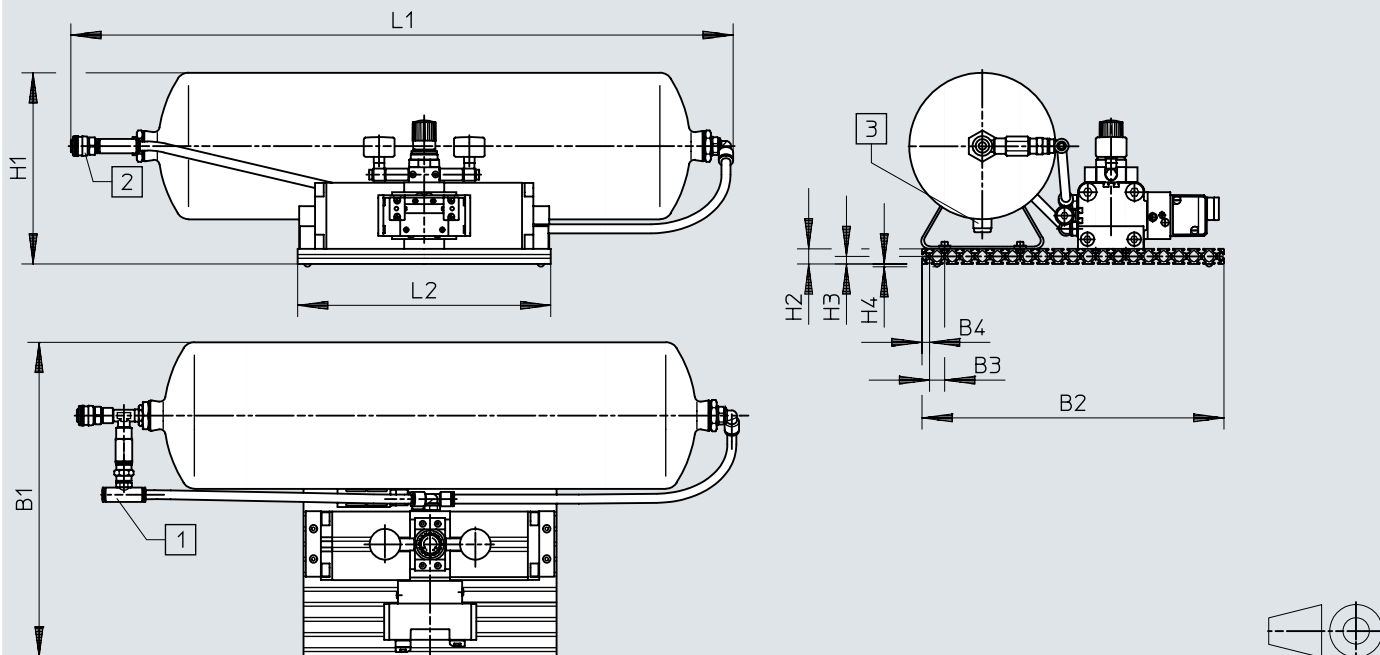

- [1] Input pressure p1
- [2] Output pressure p2, connection to coupling socket with quick coupling plug KS4
- [3] Condensate drain, max. tightening torque: 27 Nm

	B1	B2	B3	B4	H1	H2	H3	H4	L1	L2	1)	2)
DPA-63-10-CRVZS10	400	400	20	10	215	20	10	4	695	335	QSF-12	KD4-3/8
DPA-63-16-CRVZS10					253				877	335	QSF-12	KD4-3/8
DPA-63-10-CRVZS20	417				253				877	335	QSF-12	KD4-1/2
DPA-63-16-CRVZS20					253				877	335	QSF-12	KD4-1/2
DPA-100-10-CRVZS20	487	400	20	10	253	20	10	4	880	410	QSF-16	KD4-1/2
DPA-100-16-CRVZS20					253				880	410	QSF-16	KD4-1/2

- 1) For DPA-40: 4.5 bar
- 2) Coupling socket

## Dimensions

### Dimensions – Flange mounting FDPA for DPA-40

Download CAD data [www.festo.com](http://www.festo.com)

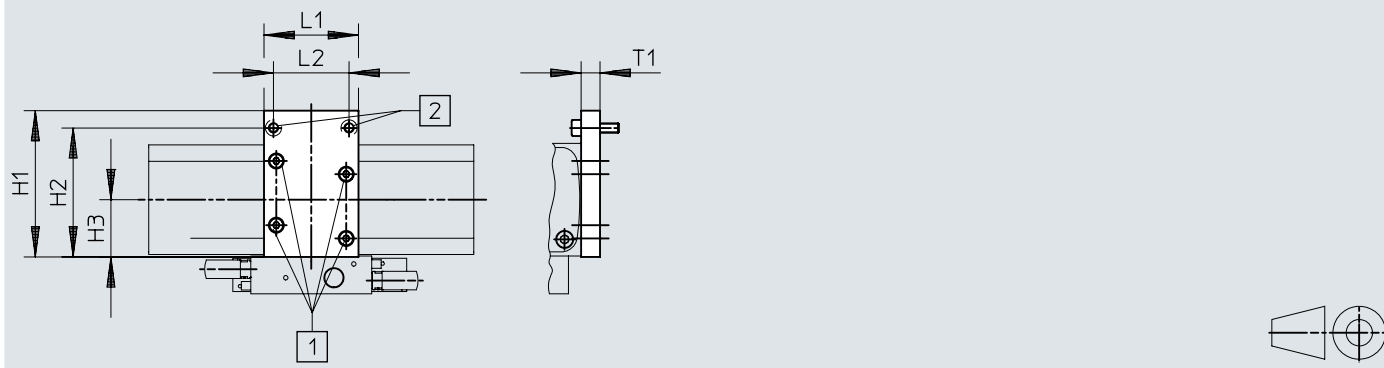

[1] M 4x12

[2] M 5x20

	H1	H2	H3	L1	L2	T1
FDPA-40	77,5	68,3	30,3	50	40	10

## Dimensions

Dimensions – Foot mounting HUA for DPA-63/100

Download CAD data [www.festo.com](http://www.festo.com)

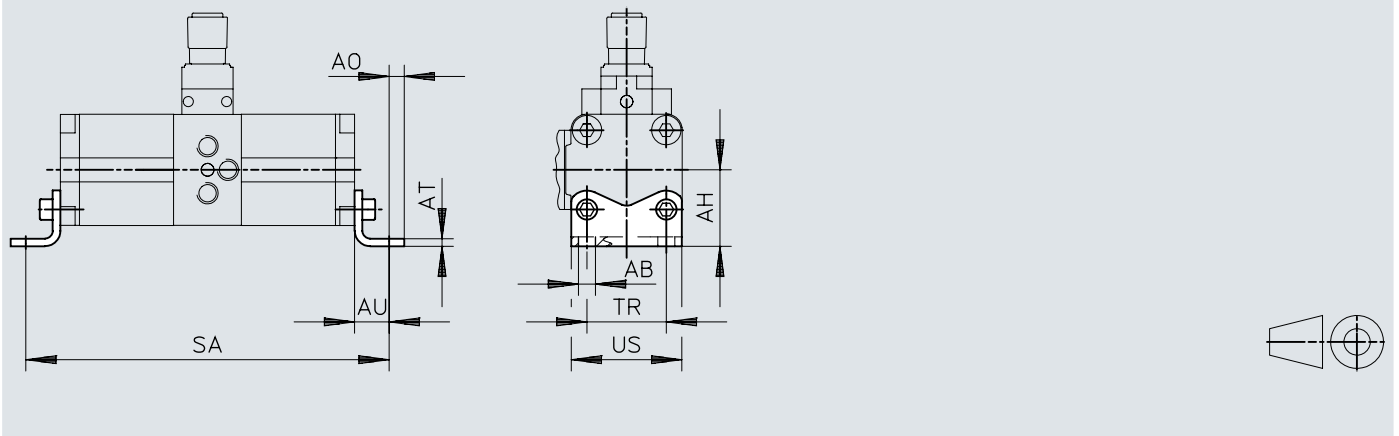

	AB ∅	AH	AO	AT	AU	SA	TR	US
HUA-63	11	56,5	11,75	6	27	343	62	85,5
HUA-100	13,5	81	11,75	8	33	433	103	126,5



## Dimensions

### Dimensions – DPA-40-...-MA-SET

Download CAD data [www.festo.com](http://www.festo.com)

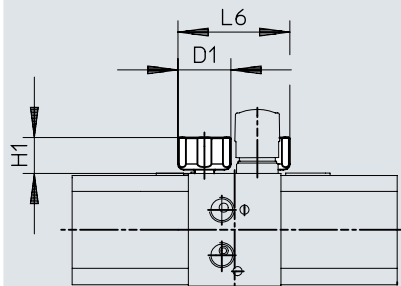

	D1 $\emptyset$	H1	L6
DPA-40-10-MA-SET	28	19	59,2
DPA-40-16-MA-SET			

## Dimensions

### Dimensions – DPA-63/100-...-MA-SET

Download CAD data [www.festo.com](http://www.festo.com)

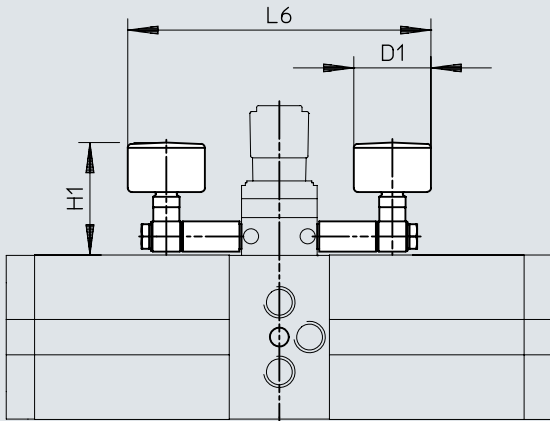

	D1 ∅	H1	L6
DPA-63-10-MA-SET	39	65	159
DPA-63-16-MA-SET			
DPA-100-10-MA-SET	39	75	173
DPA-100-16-MA-SET		82,5	

## Ordering data

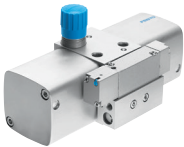
Ordering information – Pressure booster DPA						
	Piston diameter	Output pressure 2	Position sensing	Product weight	Part no.	Type
	40 mm	4.5 ... 10 bar	None	1,500 g	537273	DPA-40-10
		4.5 ... 16 bar			537274	DPA-40-16
		5 ... 16 bar			549396	DPA-40-D
	63 mm	4 ... 10 bar	None	6,000 g	184518	DPA-63-10
					For proximity sensor	549399
		4 ... 16 bar	None		549397	DPA-63-D
					For proximity sensor	193392
		4 ... 16 bar	None		549400	DPA-63-16-A
					For proximity sensor	
	100 mm	4 ... 10 bar	None	13,000 g	184519	DPA-100-10
					For proximity sensor	549401
		4 ... 16 bar	None		549398	DPA-100-D
For proximity sensor					188399	DPA-100-16
4 ... 16 bar		None	549402		DPA-100-16-A	

Ordering information – Pressure booster DPA with compressed air reservoir						
	Piston diameter	Output pressure 2	Volume	Product weight	Part no.	Type
	40 mm	4.5 ... 10 bar	2 l	4,400 g	552928	DPA-40-10-CRVZS2
			5 l	7,300 g	552930	DPA-40-10-CRVZS5
		4.5 ... 16 bar	2 l	4,400 g	552929	DPA-40-16-CRVZS2
			5 l	7,300 g	552931	DPA-40-16-CRVZS5
	63 mm	4 ... 10 bar	10 l	16,000 g	552932	DPA-63-10-CRVZS10
			20 l	21,500 g	552934	DPA-63-10-CRVZS20
		4 ... 16 bar	10 l	16,000 g	552933	DPA-63-16-CRVZS10
			20 l	21,500 g	552935	DPA-63-16-CRVZS20
	100 mm	4 ... 10 bar	30,000 g	552936	DPA-100-10-CRVZS20	
		4 ... 16 bar		552937	DPA-100-16-CRVZS20	

## Peripherals

### Peripherals overview – DPA-40-10/16/D

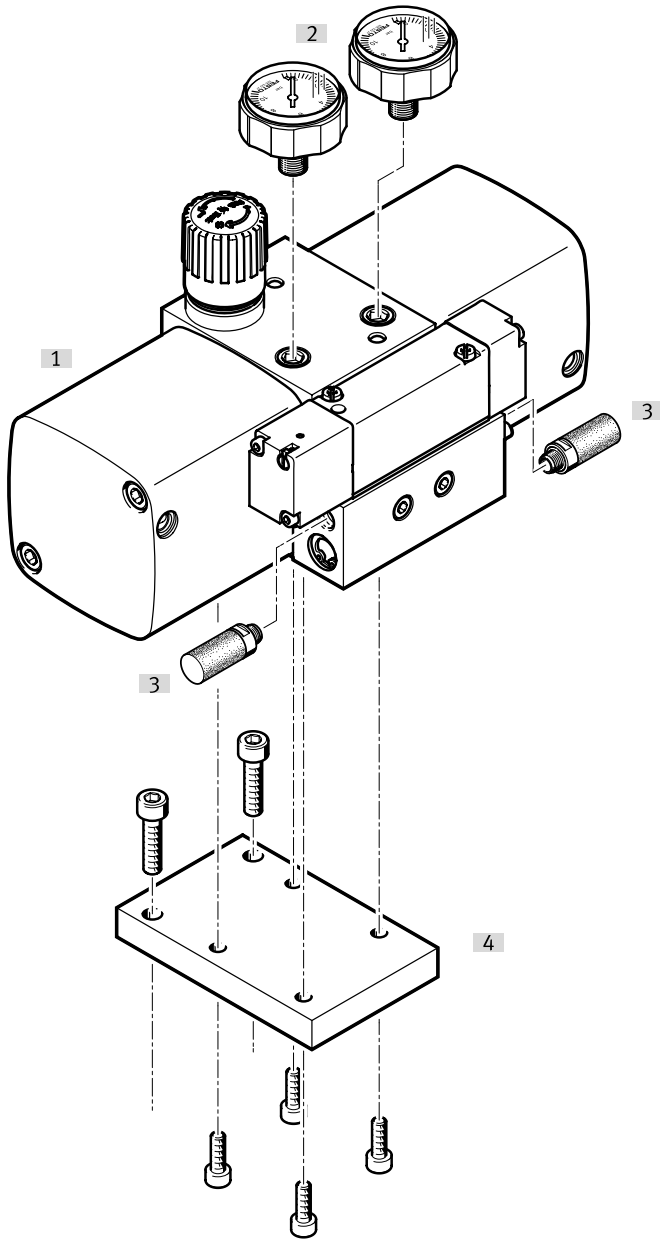

Accessories		→ Link
Type/order code	Description	
[1] Pressure booster DPA		<a href="#">dpa</a>
[2] Pressure gauge kit DPA-MA-SET	For monitoring the input and output pressure	<a href="#">24</a>
[3] Silencer UC	For noise reduction at the exhaust port	<a href="#">25</a>
[4] Flange mounting FDPA	For mounting the pressure booster on other machine parts	<a href="#">24</a>

## Peripherals

### Peripherals overview – DPA-63/100-D

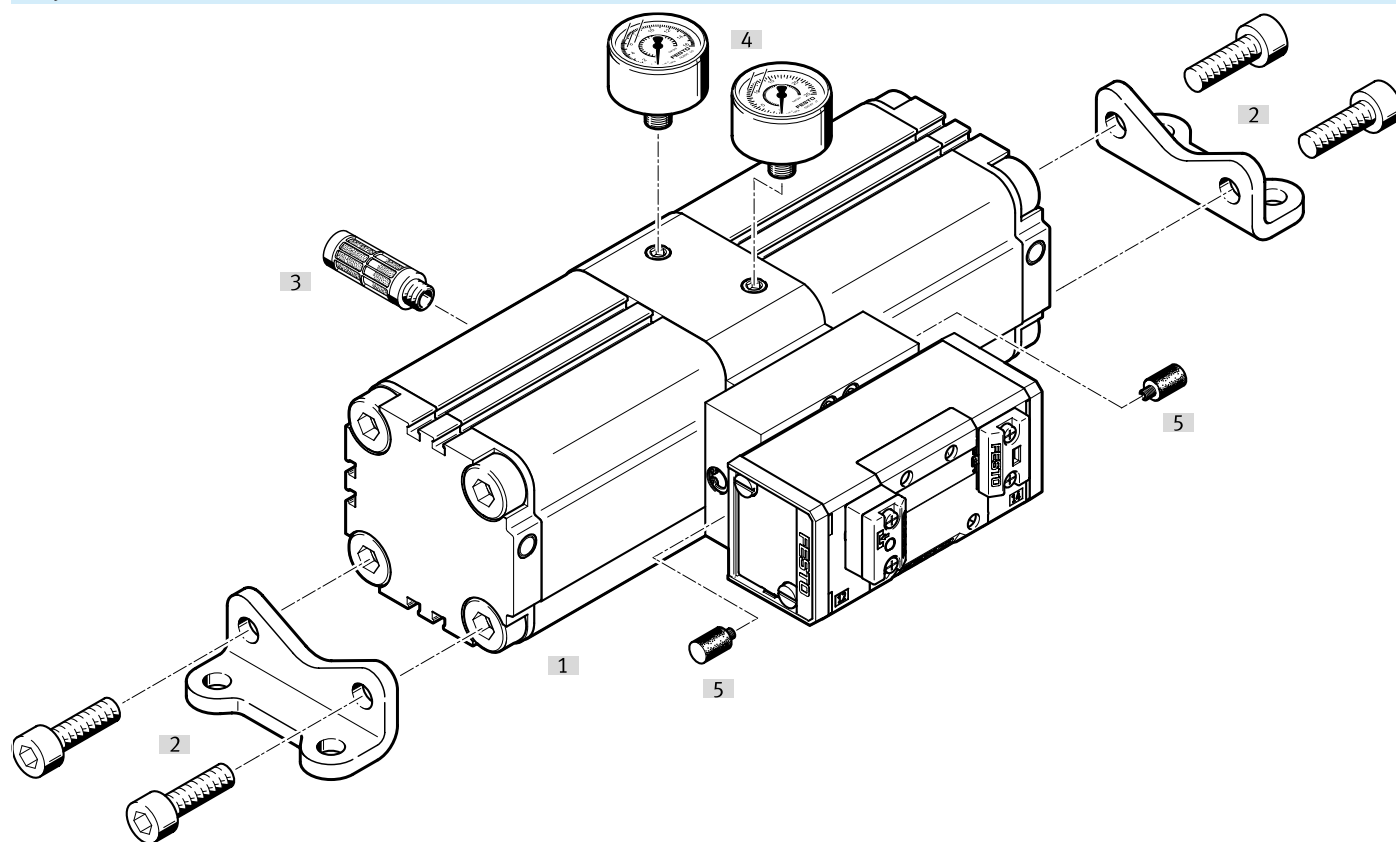

Accessories		→ Link
Type/order code	Description	
[1] Pressure booster DPA		<a href="#">dpa</a>
[2] Foot mounting HUA	For mounting the pressure booster on other machine parts	<a href="#">24</a>
[3] Silencer U-...-B	For noise reduction at the exhaust port	<a href="#">25</a>
[4] Pressure gauge MA	For monitoring the input and output pressure	<a href="#">24</a>
[5] Silencer AMTE-M-LH-M3	For noise reduction at the valve exhaust port	<a href="#">25</a>

## Peripherals

### Peripherals overview – DPA-63/100-10/16(-A)

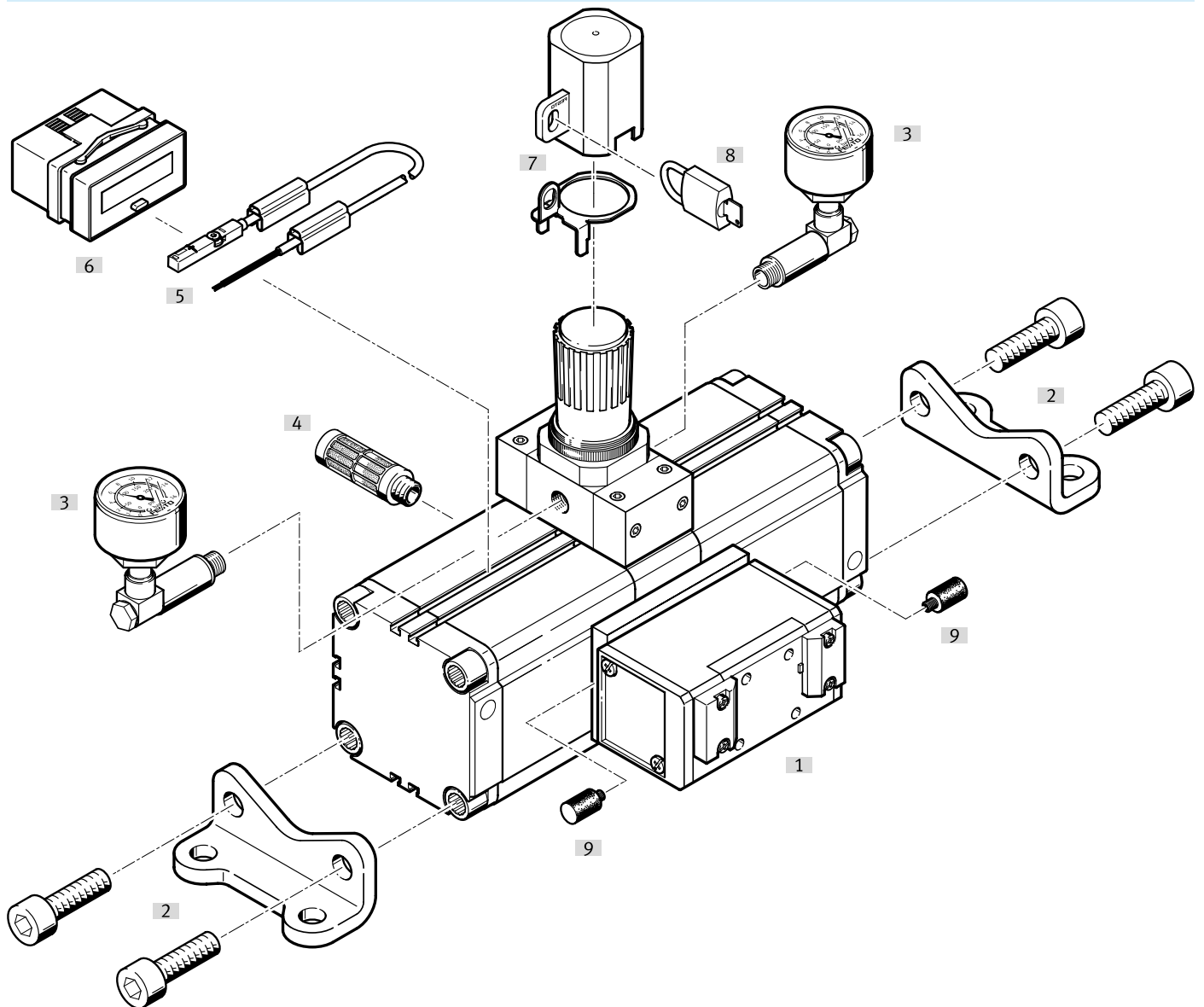

Accessories		→ Link
Type/order code	Description	
[1] Pressure booster DPA		<a href="#">dpa</a>
[2] Foot mounting HUA	For mounting the pressure booster on other machine parts	<a href="#">24</a>
[3] Pressure gauge kit DPA-MA-SET	For monitoring the input and output pressure	<a href="#">24</a>
[4] Silencer U-...-B	For noise reduction at the exhaust port	<a href="#">25</a>
[5] Proximity switch SME/SMT	For sensing individual strokes of the drive piston (DPA-...-A only)	<a href="#">25</a>
[6] Adding counter CCES	For counting the number of switching cycles (DPA-...-A only)	<a href="#">24</a>
[7] Regulator lock LRVS-D with locking plate	Prevents accidental – and, in combination with the padlock LRVS-D, unauthorised – adjustment of the rotary knob	<a href="#">26</a>
[8] Padlock LRVS-D	Accessories for regulator lock LRVS-D	<a href="#">26</a>
[9] Silencer AMTE-M-LH-M3	For noise reduction at the valve exhaust port	<a href="#">25</a>

## Peripherals

### Peripherals overview – DPA with air reservoir CRVZS

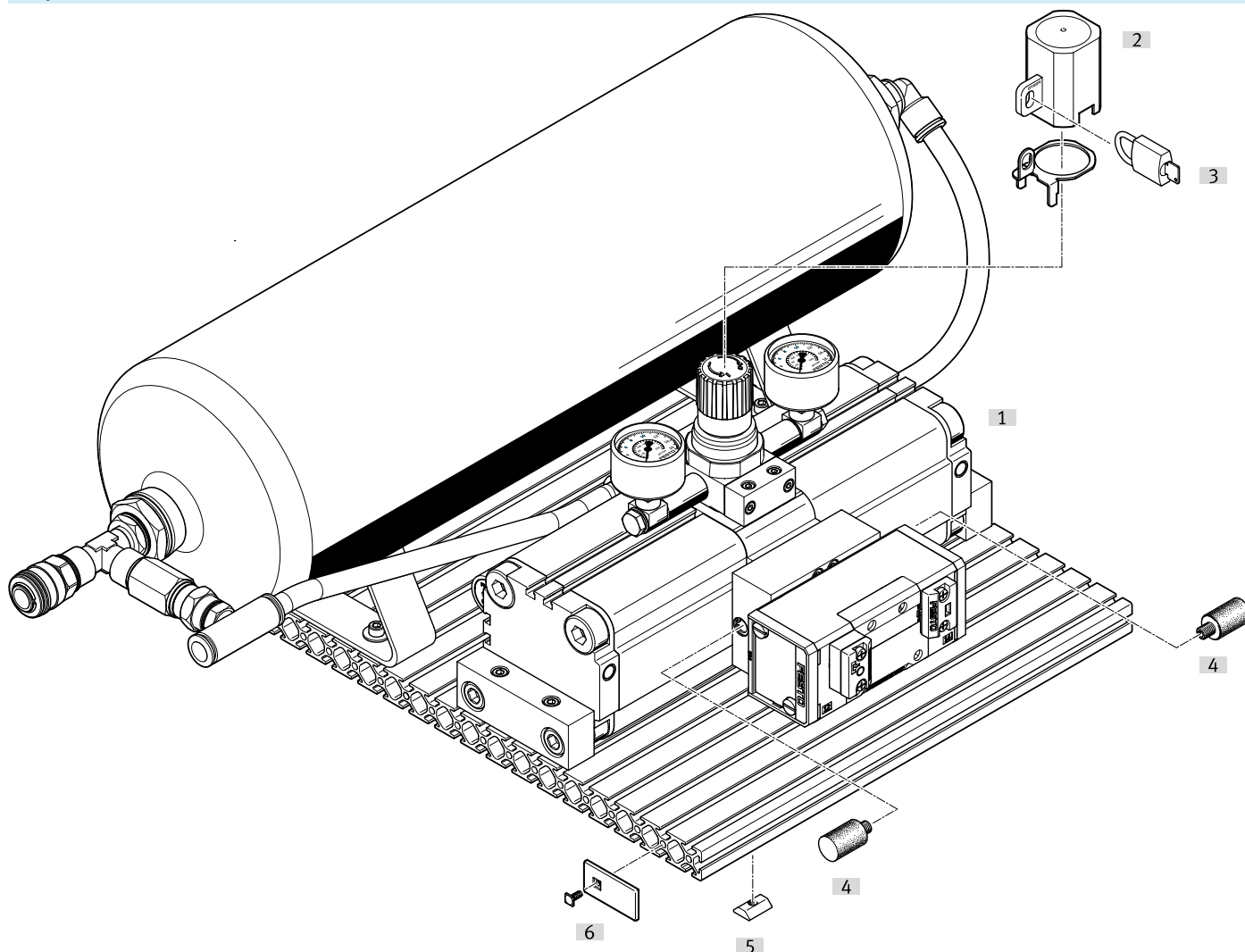

Accessories		→ Link
Type/order code	Description	
[1] Pressure booster DPA		<a href="#">dpa</a>
[2] Regulator lock LRVS-D with locking plate (only DPA-63/100)	Prevents accidental – and, in combination with the padlock LRVS-D, unauthorised – adjustment of the rotary knob	<a href="#">26</a>
[3] Padlock LRVS-D (only DPA-63/100)	Accessories for regulator lock LRVS-D	<a href="#">26</a>
[4] Silencer AMTE-M-LH-M3 (only DPA-63/100)	For noise reduction at the valve exhaust port	<a href="#">25</a>
[5] Slot nut IPM-VN-05-12/M5-ST	For mounting the profile plate (on request). DPA-40-...-CRVZS2: 4 pieces, DPA-40-...-CRVZS5: 6 pieces, DPA-63/100: 8 pieces	<a href="#">–</a>
[6] Cover cap IPM-AN-05-20X40-PA	For covering the cut edge of the profile plate (on request). DPA-40: 5 pieces per cut edge, DPA-63/100: 10 pieces per cut edge	<a href="#">–</a>

## Accessories

### Flange mounting FDPA (for DPA-40)

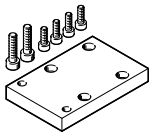
	Size	Corrosion resistance class CRC <sup>1)</sup>	Product weight	Part no.	Type
	40	2 - Moderate corrosion stress	120 g	<b>540783</b>	<b>FDPA-40</b>

1) More information visit [www.festo.com/x/topic/kbk](http://www.festo.com/x/topic/kbk)

### Foot mounting HUA (for DPA-63/100)

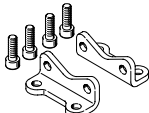
	Size	Corrosion resistance class CRC <sup>1)</sup>	Product weight	Part no.	Type
	63	2 - Moderate corrosion stress	581 g	<b>157315</b>	<b>HUA-63</b>
	100		1,117 g	<b>157317</b>	<b>HUA-100</b>

1) More information visit [www.festo.com/x/topic/kbk](http://www.festo.com/x/topic/kbk)

### Pressure gauge kit DPA-...-MA-SET

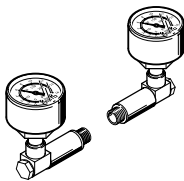
	Description	Nominal size of pressure gauge	Pneumatic connection	Measurement accuracy class	Operating pressure	Part no.	Type
	For DPA-40	27	R1/8	4	10 bar	<b>540781</b>	<b>DPA-40-10-MA-SET</b>
					16 bar	<b>540782</b>	<b>DPA-40-16-MA-SET</b>
	For DPA-63	40	G1/8	2.5	10 bar	<b>526096</b>	<b>DPA-63-10-MA-SET</b>
					16 bar	<b>526097</b>	<b>DPA-63-16-MA-SET</b>
	For DPA-100		G1/4		10 bar	<b>526098</b>	<b>DPA-100-10-MA-SET</b>
					16 bar	<b>526099</b>	<b>DPA-100-16-MA-SET</b>

### Pressure gauge MA (for DPA-63/100-D)

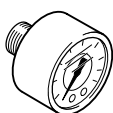
	Pneumatic connection <sup>1)</sup>	Operating pressure	Product weight	Part no.	Type
	G1/8	0 ... 25 bar	60 g	<b>526167</b>	<b>MA-40-25-1/8-EN</b>
	R1/8	0 ... 16 bar		<b>529046</b>	<b>MA-40-16-1/8-EN-DPA</b>

1) MA-40-16-1/8-EN-DPA for input pressure; MA-40-25-1/8-EN for output pressure

### Adding counter CCES (for DPA-63/100-...-A)

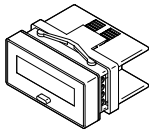
	Display	Power supply <sup>1)</sup>	Product weight	Part no.	Type
	8-digit	Lithium battery	30 g	<b>549403</b>	<b>CCES-P-C8-E</b>

1) Value retention nominal 7 years

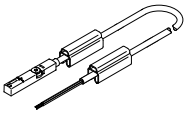

## Accessories

Proximity switch SME/SMT (for adding counter CCES)						
	Switching element function	Switching output	Cable length	Product weight	Part no.	Type
	N/O contact	Contacting, bipolar	2.5 m	29.8 g	543862	SME-8M-DS-24V-K-2,5-OE

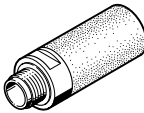
Silencer UC					
	Pneumatic connection	Flow rate to atmosphere	Product weight	Part no.	Type
	M7	800 l/min	1.2 g	★ 161418	UC-M7

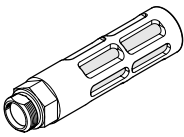
Silencer U-...-B					
	Pneumatic connection	Flow rate to atmosphere	Product weight	Part no.	Type
	G3/8	5,800 l/min	37 g	6843	U-3/8-B
	G1/2	7,500 l/min	75 g	6844	U-1/2-B

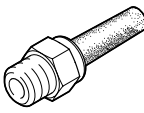
Silencer AMTE-M-LH-M3					
	Pneumatic connection	Flow rate to atmosphere	Product weight	Part no.	Type
	M3	95 l/min	0.4 g	1231120	AMTE-M-LH-M3

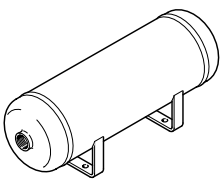
Compressed air reservoir VZS (standard)/CRVZS (stainless steel)							
	Pneumatic connection	Volume	Material air reservoir	Corrosion resistance class CRC <sup>1)</sup>	Product weight	Part no.	Type
	G1/8	0.1 l	High-alloy stainless steel	3 - high corrosion stress	226 g	160233	CRVZS-0.1
	G1/4	0.4 l			543 g	160234	CRVZS-0.4
		0.75 l			736 g	160235	CRVZS-0.75
	G1/2	2 l			1,681 g	160236	CRVZS-2
	G1	10 l	6,459 g	160237	CRVZS-10		
			10,208 g	534845	CRVZS-20		
			Powder-coated steel	4 - Very high corrosion stress	9,000 g	192161	VZS-20-B
	5 l	High-alloy stainless steel	3 - high corrosion stress	3,581 g	192159	CRVZS-5	

1) More information visit [www.festo.com/x/topic/kbk](http://www.festo.com/x/topic/kbk)

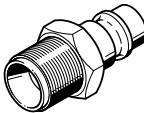
Quick coupling plug KS4					
	Pneumatic connection, port 1	Nominal size	Product weight	Part no.	Type
	Male thread G1/4	7.85 mm	21 g	2154	KS4-1/4-A

## Accessories

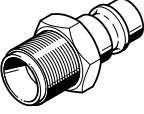
Quick coupling plug KS4						
	Pneumatic connection, port 1	Nominal size	Product weight	Part no.	Type	
	Male thread G3/8	7.85 mm	29 g	2155	KS4-3/8-A	
	Male thread G1/2		55 g	531676	KS4-1/2-A	
	Female thread G1/4		31 g	531678	KS4-1/4-I	
	Female thread G3/8		32 g	531679	KS4-3/8-I	
	Female thread G1/2		57 g	531680	KS4-1/2-I	

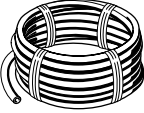
Plastic tubing PAN (for input pressure)						
	Pneumatic connection	Shore hardness	Colour	Product weight according to length	Part no.	Type
	For push-in connector O.D. 10 mm	D 55 +/-3	Blue	0.042 kg/m	553909	PAN-10X1,5-BL
	For push-in connector outside diameter of 12 mm			0.06 kg/m	553910	PAN-12X1,75-BL
	For push-in connector O.D. 16 mm			0.092 kg/m	553911	PAN-16X2-BL

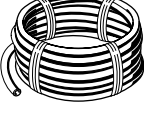
Plastic tubing PAN-R (for output pressure)						
	Pneumatic connection	Shore hardness	Colour	Product weight according to length	Part no.	Type
	For push-in connector O.D. 8 mm	D 62 +/-3	Silver	0.032 kg/m	541676	PAN-R-8X1,5-SI
	For push-in connector O.D. 10 mm			0.05 kg/m	541677	PAN-R-10X1,9-SI
	For push-in connector outside diameter of 12 mm			0.07 kg/m	541678	PAN-R-12X2,2-SI
	For push-in connector O.D. 16 mm			0.126 kg/m	541679	PAN-R-16X3-SI

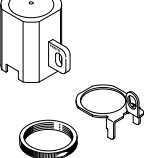
Regulator lock LRVS-D (for DPA-63/100)						
	Short type code	Product weight		Part no.	Type	
	LRVS	40 g		193781	LRVS-D-MINI	
		60 g		193782	LRVS-D-MIDI	

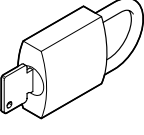
Padlock LRVS-D						
	Short type code	Product weight		Part no.	Type	
	LRVS-D	120 g		193786	LRVS-D	