

Air reservoir VZS

FESTO



Characteristics

At a glance

- To compensate for pressure fluctuations and as accumulators in the event of sudden air consumption.
- Providing large volumes of compressed air for supplying fast-pulsing drives.
- Delay times for pressure build-up can be achieved in combination with throttle valves.
- High corrosion protection

Volume [l]

[20] 20

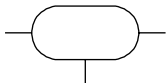

With condensate drain

Type code

001	Series
VZS	Air reservoir

003	Version
B	Second generation

002	Volume [l]
20	20

Datasheet

General technical data

Pneumatic connection	G1
Volume ¹⁾	20 l
Type of mounting	With through-hole
Condensate drain connection	G3/8
Max. tightening torque for connecting thread	130 Nm
Max. tightening torque for condensate drain	27 Nm
Mounting position	Condensate drain underneath

1) Tolerance: ±10%

Operating and environmental conditions

Pneumatic connection	G1
Operating pressure	-0.095 ... 1.6 MPa
Operating pressure	-0.95 ... 16 bar
Operating pressure	-13.775 ... 232 psi
Operating medium	Compressed air to ISO 8573-1:2010 [:-:-] Nitrogen
Ambient temperature	-10 ... 100°C
Media temperature	-10 ... 100°C
Corrosion resistance class CRC ¹⁾	4 - Very high corrosion stress
Conforms to standard	EN 286-1
CE mark (see declaration of conformity) ²⁾	In accordance with EU Directive on Simple Pressure Vessels

1) More information www.festo.com/x/topic/crc2) More information www.festo.com/catalogue/vzs → Support/Downloads.**Materials**

Material air reservoir	Powder-coated steel
LABS (PWIS) conformity	VDMA24364-B1/B2-L

Dimensions

Dimensions – VZS-20-B

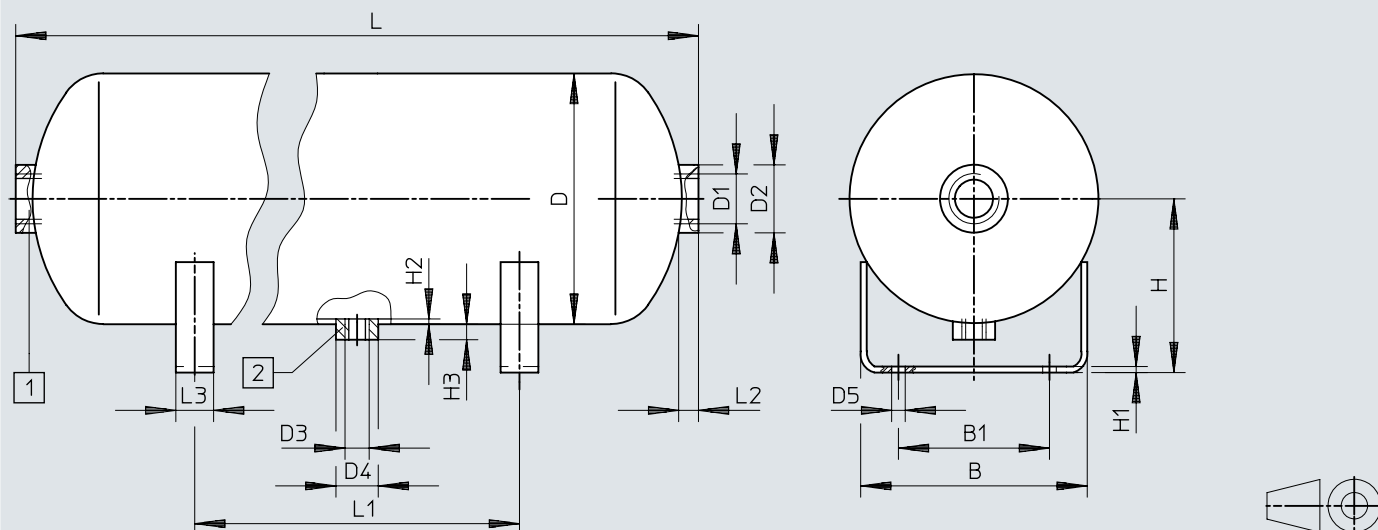
Download CAD data → www.festo.com

[1] Max. tightening torque for connecting thread 130 Nm

[2] Max. tightening torque for condensate drain 27 Nm

	B ±2	B1 ±1	D ±4 ∅	D1	D2 ∅	D3	D4 ∅	D5 ±0,5 ∅
VZS-20-B	150	100	206	G1	44,5	G3/8	28	9
	H ±1,5	H1	H2 min.	H3	L ±6	L1 ±1,5	L2	L3
VZS-20-B	146,5	4	2	12	696	300	18	25

Ordering data

Ordering data				
	Volume ¹⁾	Product weight	Part no.	Type
	20 l	9,000 g	192161	VZS-20-B

1) Tolerance: ±10%