

Standards-based cylinder CRDNG

FESTO

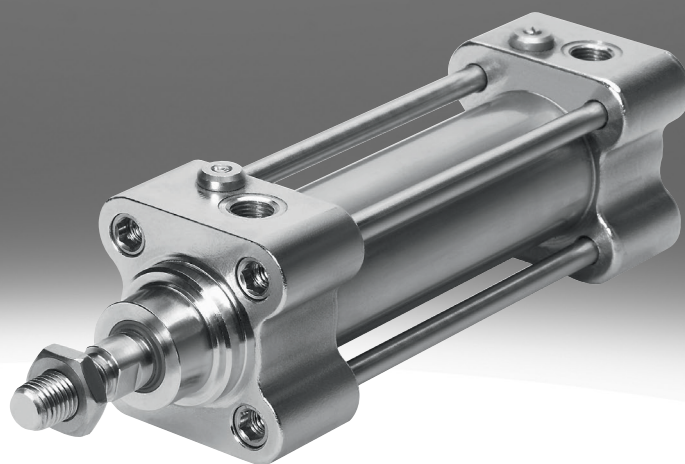

Characteristics

At a glance

[Link !\[\]\(99f58673407353e96a019fbca558fd72_img.jpg\) crdng](#)

Features of stainless-steel cylinders:

Their applications:

- Even in harsh operating environments, components have to be sturdy and totally reliable. The aim is to achieve high availability while reducing downtimes in machine systems. Wherever pneumatic drives stand no chance because their surface quality cannot withstand the surrounding media, stainless steel cylinders are the best choice. The corrosion-proof design of systems requires not only the selection of a suitable steel, but also a matching range of mounting components and accessories.
- Application example: In the maturing cellar of a cheese factory, stainless-steel cylinders are surrounded by an atmosphere with an unpleasant mix of ammonia, lactic acid and 98% humidity.

Our strength:

- Stainless-steel cylinders from Festo are characterised by resistant materials, such as 1.4301 and 1.4401. These popular high-alloy, stainless austenitic chrome-nickel and chrome-nickel-molybdenum steels protect against chemical or electrochemical stress as well as damage to the material surfaces caused by cleaning agents and disinfectants. These material groups are particularly resistant to even surface corrosion and offer increased protection against pitting and crevice corrosion.

The benefit to you:

- Our stainless steel cylinders are globally available thanks to the worldwide Festo service network. We offer an extensive range of standards-based cylinders to DIN ISO 15552 and 6432. In addition, we supply a range of mounting components and accessories tailored to the cylinders. The stainless steel cylinders are provided with NSF-H1 compliant greases and with wipers according to BGVV (Federal Institute for Risk Assessment) guidelines. They can thus be used in the food sector. We would be happy to inform you about future additions to our stainless-steel program. Take advantage of this opportunity and get in touch with us!

Good to know:

- For difficult applications, you can rely on our years of experience in stainless steel. Our experts will answer any questions you might have about surface finishes and chemical resistance.

Resistant to:

- Absolute resistance to pitting and crevice corrosion is not always guaranteed, even with ideal application parameters. Parameters such as a concentration of chloride ions, contact time, temperature and decreasing pH value increase the pitting effect of chloride ions. It must be therefore be ensured that, during design, assembly and operation, all areas of the system can be well flushed to avoid a concentration of chloride ions.
- Selected sealing materials ensure very high resistance to numerous chemical compounds. Further information on media resistance can be found on the Internet at www.festo.com.
- In many industry sectors, machinery gets exposed to different kinds of contamination and therefore needs to be cleaned. The extent of the cleaning process ranges from dry wiping of the system to wet cleaning and foam cleaning with different application times and concentrations. A general recommendation on compatibility is therefore not possible. In principle, we recommend cleaning with the piston rod retracted to avoid washing out the lifetime lubrication.

Diagrams

[Link !\[\]\(235bfe13ebf007ce2eea9e689707fac7_img.jpg\) crdng](#)

The diagrams shown in this document are also available online. These can be used to display precise values.

Series

[CRDNG] Standard-based cylinder, double-acting, based on ISO 15552, stainless steel

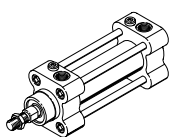

CRDNG: standard design

[CRDNGS] Standards-based cylinder with swivel flange, double-acting, based on ISO 15552, stainless steel

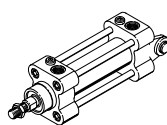

CRDNGS: version with swivel flange

Characteristics

Cushioning

End-position cushioning has the following functions:

- Reduces kinetic energy in the end positions
- Avoids vibrations
- Reduces noise generation

[PPV] Pneumatic cushioning, adjustable at both ends

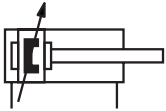

The drive is fitted with pneumatic end-position cushioning, which can be adapted by the operator for maximum performance according to the moving mass and speed.

Benefits:

- Very powerful

Position sensing

[A] For proximity sensor

By using proximity switches, any position can be detected.

Piston rod type

[S2] Through piston rod



- The piston rod can be used for connection at one end of the cylinder
- Identical forces in the forward and return stroke

Temperature range

[S6] Heat-resistant seals max. 120 °C



For use in the temperature range 0 ... +120 °C

Type code

001	Series
CRDNG	Standard-based cylinder, double-acting, based on ISO 15552, stainless steel
CRDNGS	Standards-based cylinder with swivel flange, double-acting, based on ISO 15552, stainless steel

002	Piston diameter [mm]
32	32
40	40
50	50
63	63
80	80
100	100
125	125

003	Stroke range [mm]
...	10 ... 2000

004	Cushioning
PPV	Pneumatic cushioning, adjustable at both ends

005	Position sensing
A	For proximity sensor

006	Piston rod type
	At one end
S2	Through piston rod

007	Temperature range
	Standard
S6	Heat-resistant seals max. 120 °C

Datasheet

General technical data							
Piston diameter	32 mm	40 mm	50 mm	63 mm	80 mm	100 mm	125 mm
Stroke	10 ... 2,000 mm						
Pneumatic connection	G1/8	G1/4		G3/8		G1/2	
Piston rod thread	M10x1.25	M12x1.25	M16x1.5		M20x1.5		M27x2
Design	Piston Piston rod Swivel clevis Tie rod Cylinder barrel						
Cushioning	Pneumatic cushioning, adjustable at both ends						
Cushioning length	19 mm	21 mm	23 mm	30 mm		40 mm	
Position detection	Via proximity switch						
Type of mounting	Via female thread With accessories Either:						
Mounting position	optional						

Operating and environmental conditions	
Temperature range	Standard Heat-resistant seals max. 120°C
Conforms to standard	ISO 15552
Operating medium	Compressed air to ISO 8573-1:2010 [7:4:4]
Note on operating and pilot medium	Lubricated operation possible (in which case lubricated operation will always be required)
Operating pressure	0.06 ... 1 MPa
Operating pressure	0.6 ... 10 bar
Operating pressure	8.7 ... 145 psi
Ambient temperature ¹⁾	-20 ... 80°C 0 ... 120°C
Suitable for use with food ²⁾	See supplementary material information
Corrosion resistance class CRC ³⁾	4 - Very high corrosion stress

1) Note the operating range of the proximity switches.

2) CRDNG-...S6: Not suitable for direct contact with food products because of the seals and the grease used.

More information www.festo.com/sp/Certificates

3) More information: www.festo.com/x/topic/crc

Forces for Ø 32 ... 63								
Piston diameter	32 mm		40 mm		50 mm		63 mm	
Piston rod type	At one end	Through piston rod	At one end	Through piston rod	At one end	Through piston rod	At one end	Through piston rod
Theoretical force at 0.6 MPa (6 bar, 87 psi), advance stroke	483 N		754 N	633 N	1,178 N	990 N	1,870 N	1,682 N
Theoretical force at 0.6 MPa (6 bar, 87 psi), return stroke	415 N		633 N		990 N		1,682 N	

Forces for Ø 80 ... 125						
Piston diameter	80 mm		100 mm		125 mm	
Piston rod type	At one end	Through piston rod	At one end	Through piston rod	At one end	Through piston rod
Theoretical force at 0.6 MPa (6 bar, 87 psi), advance stroke	3,016 N	2,721 N	4,712 N	4,418 N	7,363 N	6,881 N
Theoretical force at 0.6 MPa (6 bar, 87 psi), return stroke	2,721 N		4,418 N		6,881 N	

Weights for CRDNG-...							
Piston diameter	32 mm	40 mm	50 mm	63 mm	80 mm	100 mm	125 mm
Basic weight for 0 mm stroke	1,040 g	1,420 g	2,260 g	3,555 g	5,545 g	8,330 g	15,500 g
Additional weight per 10 mm stroke	25 g	33 g	56 g	60 g	92 g	99 g	156 g
Moving mass for 0 mm stroke	154 g	268 g	485 g	609 g	1,018 g	1,310 g	2,523 g
Additional moving mass per 10 mm stroke	9 g	16 g	25 g		39 g		64 g

Datasheet

Weights for CRDNG-...-S2 - Through piston rod

Piston diameter	32 mm	40 mm	50 mm	63 mm	80 mm	100 mm	125 mm
Basic weight for 0 mm stroke	1,078 g	1,519 g	2,469 g	3,779 g	5,898 g	8,772 g	16,402 g
Additional weight per 10 mm stroke	34 g	49 g	81 g	85 g	131 g	138 g	220 g
Moving mass for 0 mm stroke	203 g	363 g	679 g	817 g	1,364 g	1,688 g	3,239 g
Additional moving mass per 10 mm stroke	18 g	32 g	50 g		78 g		128 g

Weights for CRDNGS-...

Piston diameter	32 mm	40 mm	50 mm	63 mm	80 mm	100 mm	125 mm
Basic weight for 0 mm stroke	1,104 g	1,515 g	2,419 g	3,807 g	5,804 g	8,897 g	16,543 g
Additional weight per 10 mm stroke	25 g	33 g	56 g	60 g	92 g	99 g	156 g
Moving mass for 0 mm stroke	154 g	268 g	485 g	609 g	1,018 g	1,310 g	2,523 g
Additional moving mass per 10 mm stroke	9 g	16 g	25 g		39 g		64 g

Materials

Temperature range	Standard	Heat-resistant seals max. 120°C
Material housing	High-alloy stainless steel	
Material cover	Stainless steel casting	
Material cylinder barrel	High-alloy stainless steel	
Material piston rod	High-alloy stainless steel	
Material piston	Wrought aluminium alloy	
Material bearing	POM	Metal polymer compound
Material tie rod	High-alloy stainless steel	
Material seals	TPE-U(PU)	FPM
Material collar nut	High-alloy stainless steel	
Material nut	High-alloy stainless steel	
LABS (PWIS) conformity	VDMA24364-B2-L	

Dimensions

Dimensions – Standard design

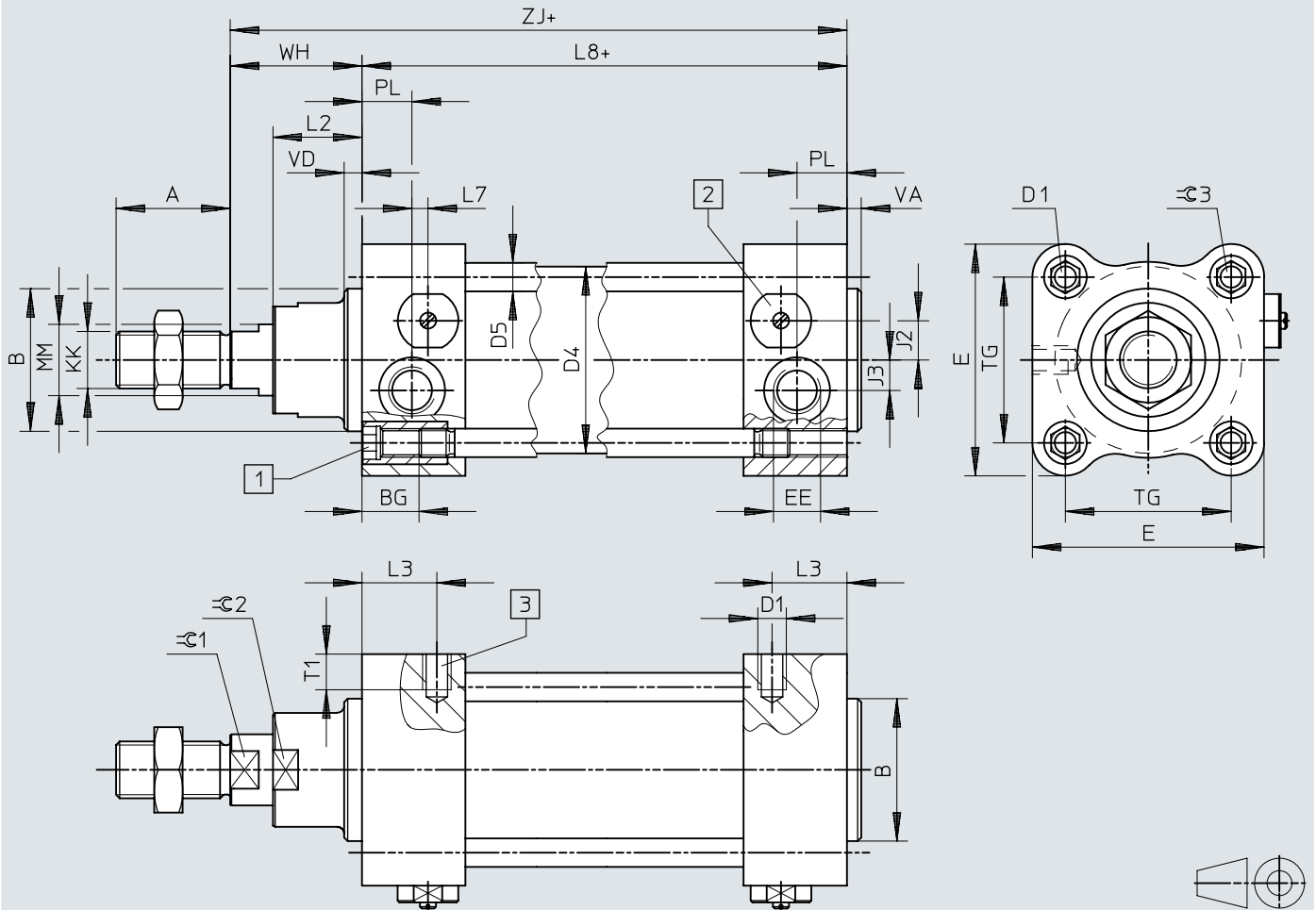
Download CAD data www.festo.com

- [1] Socket head screw with female thread
- [2] Cover for adjustable end-position cushioning
- [3] Threaded hole for direct mounting
- [4] + = plus stroke length

Dimensions

	A	B ∅ e11	BG	D1	D4 ∅	D5 ∅	E	EE	J2	J3	KK	L2	L3
CRDNG-32	22	30	16	M6	33,6	6	50	G1/8	7	5,7	M10x1,25	16	13
CRDNG-40	24	35	16	M6	41,6	6	55	G1/4	10	6,5	M12x1,25	18	16,5
CRDNG-50	32	40	16	M8	52,4	8	65	G1/4	11,5	8,6	M16x1,5	25	21
CRDNG-63	32	45	16	M10	65,4	8	75	G3/8	14,5	12	M16x1,5	25	22
CRDNG-80	40	45	23	M10	82,8	10	100	G3/8	15	13	M20x1,5	31	22,5
CRDNG-100	40	55	23	M12	102,8	10	120	G1/2	23	14	M20x1,5	36	22,5
CRDNG-125	54	60	23	M12	128,6	12	145	G1/2	28,5	8	M27x2	46	23,5

	L7	L8	MM ∅	PL	RT	T1	TG	VA	VD	WH	ZJ	≅C1	≅C2	≅C3
CRDNG-32	5,3	94 +0,4	12	13	M6	9	32,5	4	6	26	120	10	26	6
CRDNG-40	2,5	105 +0,4/-0,6	16	14	M6	9	38	4	6	30	135	13	30	6
CRDNG-50	4,5	106 +0,4/-0,6	20	14	M8	10	46,5	4	6	37	143	17	34	8
CRDNG-63	5	121 +0,4/-0,6	20	18	M8	12	56,5	4	6	37	158	17	36	8
CRDNG-80	6	128 +0,4/-0,6	25	17	M10	15	72	4	7	46	174	22	41	10
CRDNG-100	9	138 +0,4/-0,6	25	18	M10	18	89	4	7	51	189	22	41	10
CRDNG-125	4,5	160 +0,4/-0,6	32	27	M12	18	110	6	6	66	226	27	50	12

Dimensions

Dimensions – CRDNG-...-S2 – Through piston rod

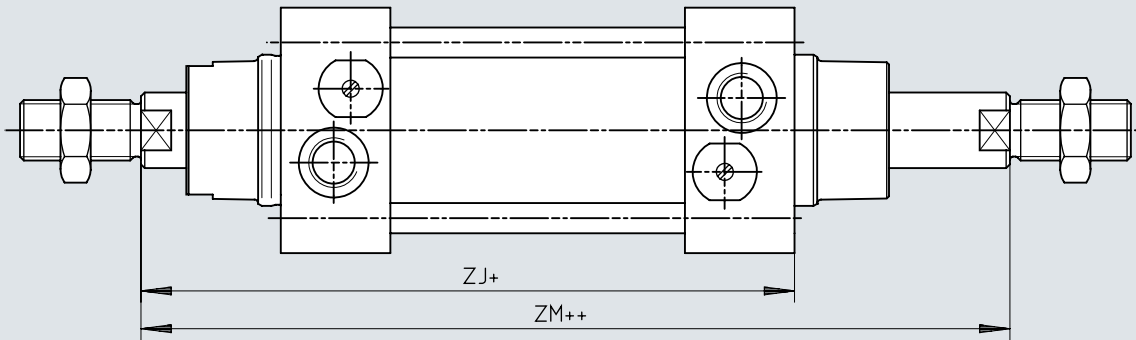
Download CAD data www.festo.com

- [1] + = plus stroke length
 [2] ++ = plus 2x stroke length

	ZJ	ZM
CRDNG-32	120	148
CRDNG-40	135	167
CRDNG-50	143	183
CRDNG-63	158	199
CRDNG-80	174	222
CRDNG-100	189	240
CRDNG-125	226	292

Dimensions

Dimensions – CRDNGS-... – With swivel flange

Download CAD data www.festo.com

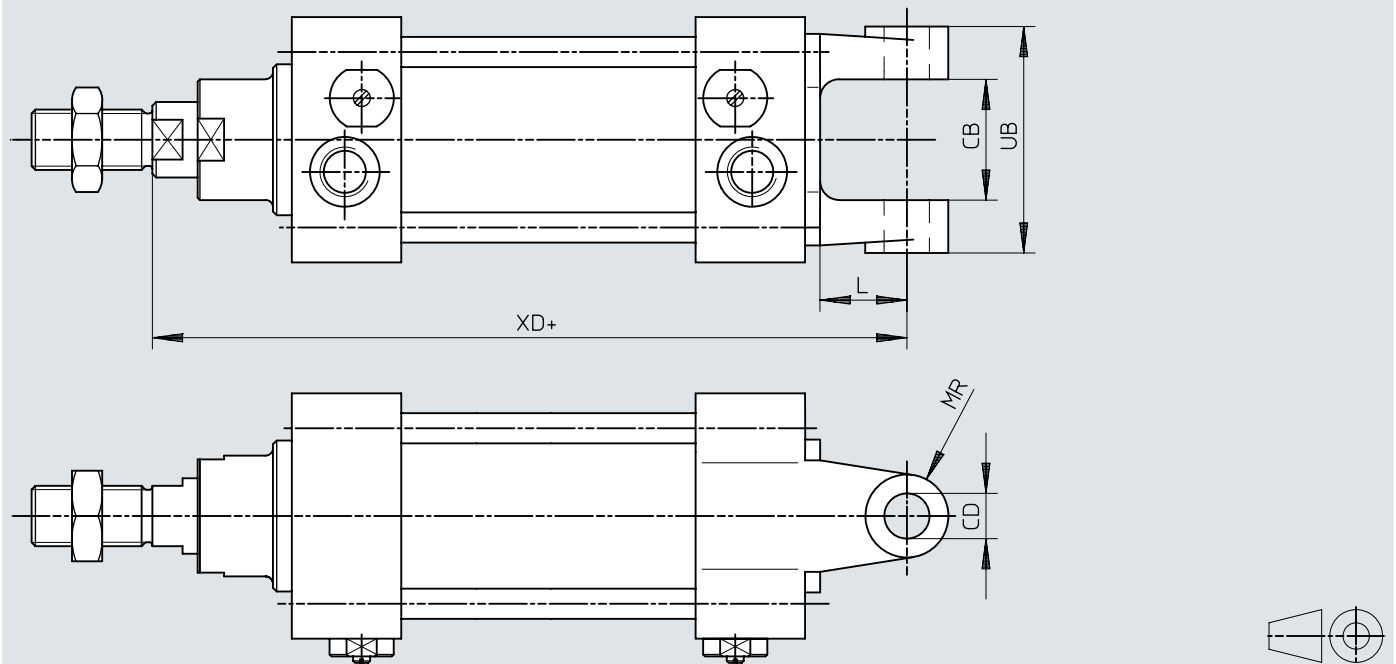

[1] += plus stroke length

	CD ∅ H9	L	CB H14	MR	UB	XD
CRDNG-32	10	18	26	9	45	142
CRDNG-40	12	21	28	10	52	160
CRDNG-50	12	23	32	11	60	170
CRDNG-63	16	28	40	13	70	190
CRDNG-80	16	32	50	13	90	210
CRDNG-100	20	37	60	17	110	230
CRDNG-125	25	44	70	23	130	276

Dimensions

Dimensions – Foot mounting CRHNC

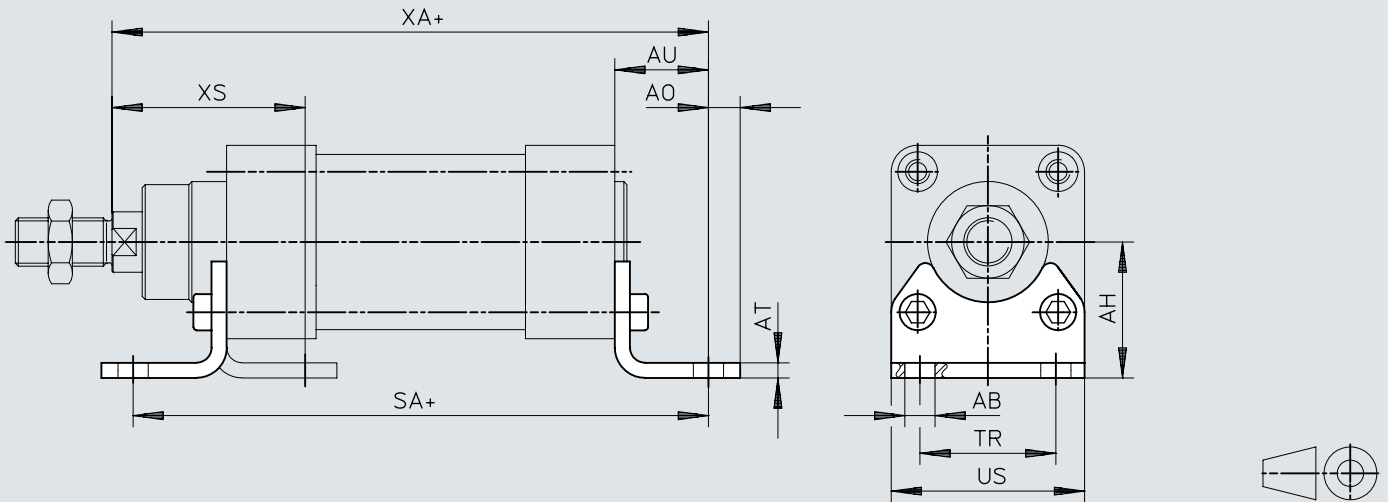
Download CAD data www.festo.com

[1] += plus stroke length

	AB ø	AH	AO	AT	AU	SA	TR	US	XA	XS
CRHNC-32	7	32	6,5	4	24	142	32	45	144,7	45,7
CRHNC-40	10	36	9	4	28	160,8	36	54	163,6	53,8
CRHNC-50	10	45	9,5	5	31	167,9	45	64	175	63,1
CRHNC-63	10	50	12,5	5	32	184,9	50	75	191,5	64,6
CRHNC-80	12	63	15	6	41	209,9	63	93	215,5	81,6
CRHNC-100	14,5	71	17,5	6	41	220,1	75	110	229,6	85,5
CRHNC-125	16,5	90	22	8	45	250	90	131	270	102

Dimensions

Dimensions – Flange mounting CRFNG

Download CAD data www.festo.com

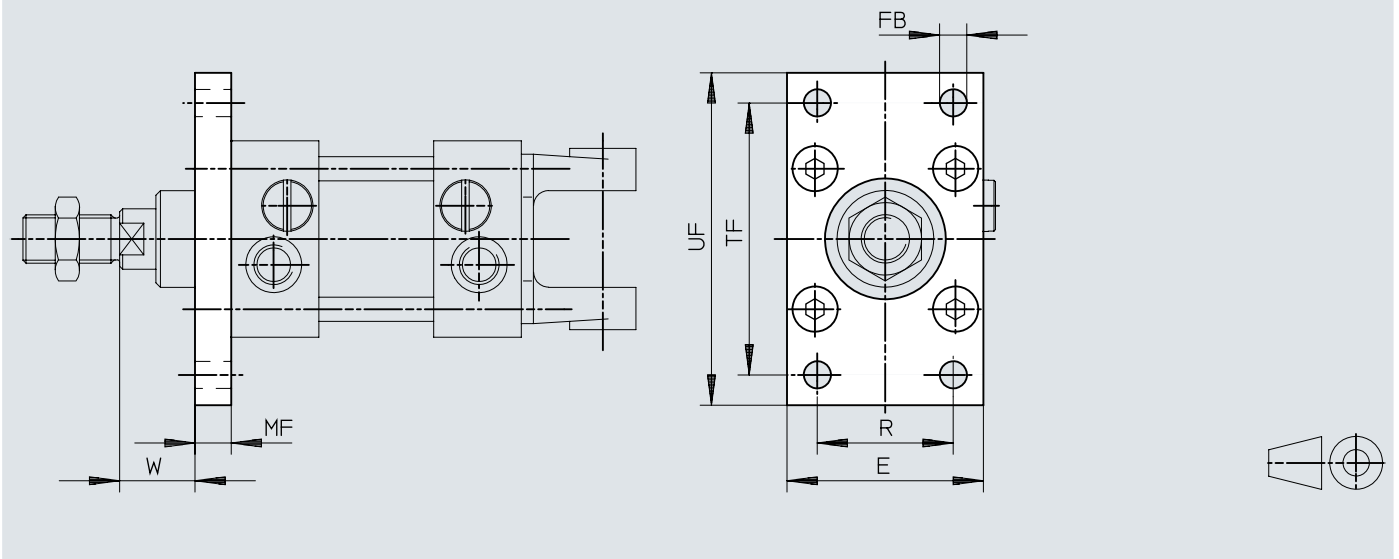

	E	FB ∅	MF	R	TF	UF	W
CRFNG-32	45	7	10	32	64	80	16
CRFNG-40	54	9	10	36	72	90	20
CRFNG-50	65	9	12	45	90	110	25
CRFNG-63	75	9	12	50	100	120	25
CRFNG-80	93	12	16	63	126	150	30
CRFNG-100	110	14	16	75	150	175	35
CRFNG-125	132	16	20	90	180	210	45

Dimensions

Dimensions – Trunnion flange CRZNG

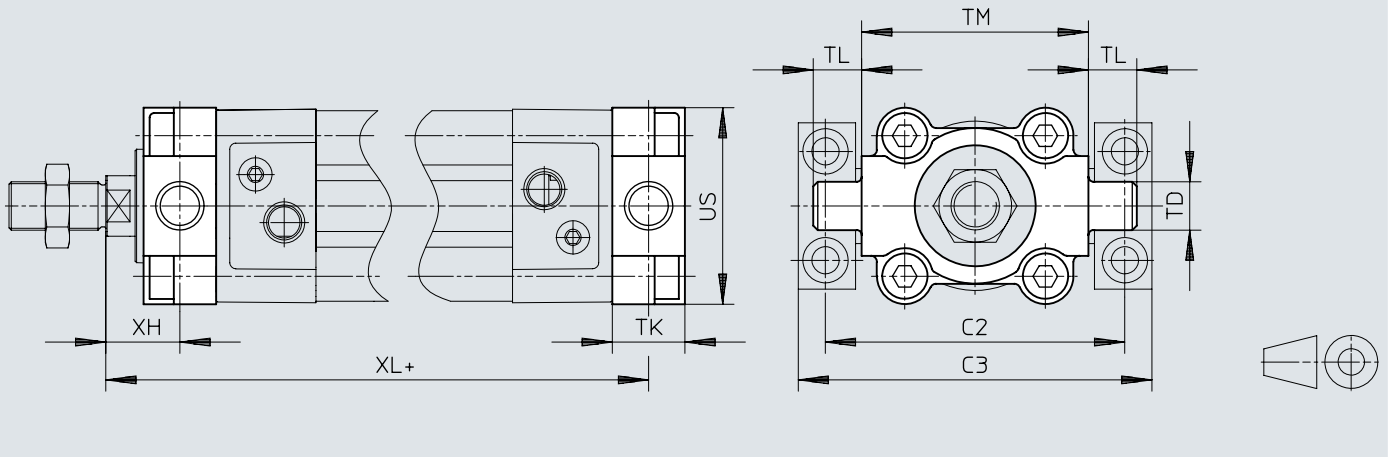
Download CAD data www.festo.com

	C2	C3	TD ø e9	TK	TL	TM	UW	XH	XL
CRZNG-32	71	86	12	16	12	50	50	18	128
CRZNG-40	87	105	16	20	16	63	55	20	145
CRZNG-50	99	117	16	24	16	75	65	25	155
CRZNG-63	116	136	20	24	20	90	75	25	170
CRZNG-80	136	156	20	28	20	110	100	32	188
CRZNG-100	164	189	25	38	25	132	120	32	208
CRZNG-125	192	217	25	50	25	160	150	40	250

Dimensions

Dimensions – Trunnion supports CRLNZG

Download CAD data www.festo.com

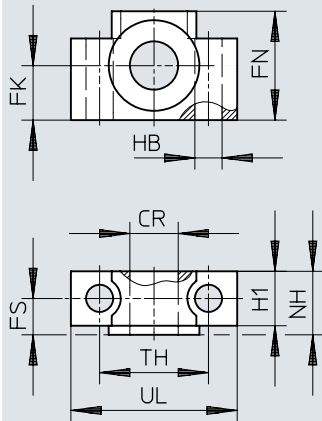

	CR ∅ D11	FK ∅ ±0,1	FN	FS	H1	HB ∅ H13	NH	TH ±0,2	UL
CRLNZG-32	12	15	30	10,5	15	6,6	18	32	46
CRLNZG-40/50	16	18	36	12	18	9	21	36	55
CRLNZG-63/80	20	20	40	13	20	11	23	42	65
CRLNZG-100/125	25	25	50	16	24,5	14	28,5	50	75

Dimensions

Dimensions – Clevis foot CRLNG

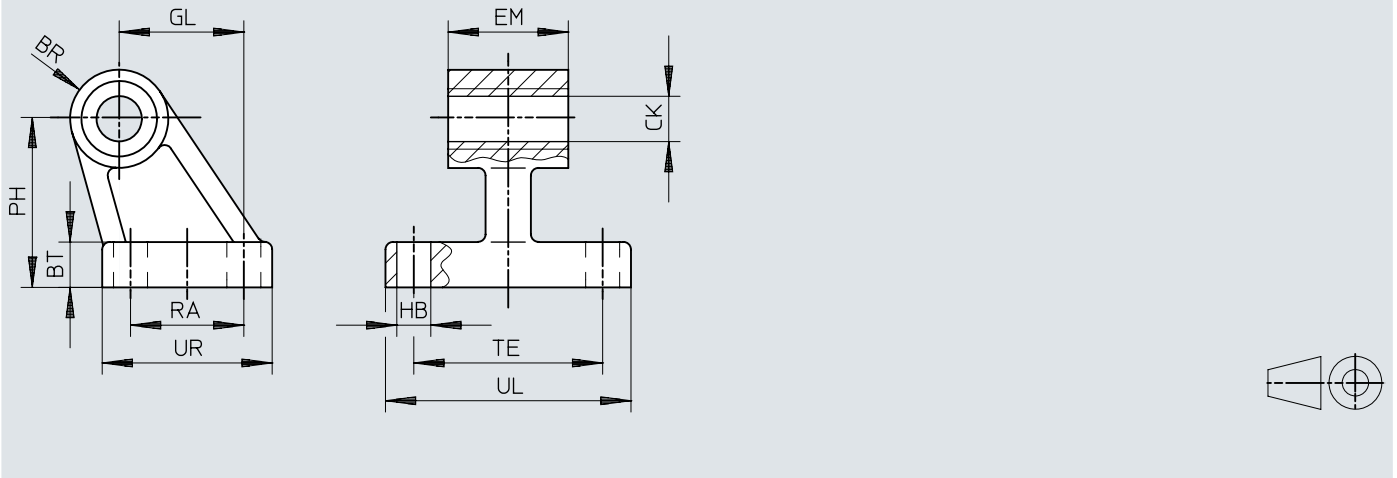
Download CAD data www.festo.com

	BR	BT	CK ∅ D11	EB ∅ H13	EM -0,4	GL	HB ∅ H13	OF	PH	RA	TE	UL	UR
CRLNG-32	10	8	10	-	25,8	21	6,6	-	32	18	38	51	31
CRLNG-40	11	10	12	-	27,8	24	6,6	-	36	22	41	54	35
CRLNG-50	12	12	12	-	31,8	33	9	-	45	30	50	65	45
CRLNG-63	15	12	16	15	39,8	37	9	10,8	50	35	52	67	50
CRLNG-80	15	14	16	18	49,8	47	11	12,7	63	40	66	86	60
CRLNG-100	19	15	20	18	59,8	55	11	13,7	71	50	76	96	70
CRLNG-125	22	20	25	20	69,8	70	14	18,6	90	60	94	124	90

Ordering data

CRDNG-...				
	Piston diameter	Stroke	Part no.	Type
	32 mm	10 ... 2000 mm	160884	CRDNG-32- -PPV-A
	40 mm		160885	CRDNG-40- -PPV-A
	50 mm		160886	CRDNG-50- -PPV-A
	63 mm		160887	CRDNG-63- -PPV-A
	80 mm		160888	CRDNG-80- -PPV-A
	100 mm		160889	CRDNG-100- -PPV-A
	125 mm		185280	CRDNG-125- -PPV-A

CRDNG-...-S6 – Heat-resistant seals up to max. 120 °C				
	Piston diameter	Stroke	Part no.	Type
	32 mm	10 ... 2000 mm	185293	CRDNG-32- -PPV-A-S6
	40 mm		185294	CRDNG-40- -PPV-A-S6
	50 mm		185295	CRDNG-50- -PPV-A-S6
	63 mm		185296	CRDNG-63- -PPV-A-S6
	80 mm		185297	CRDNG-80- -PPV-A-S6
	100 mm		185298	CRDNG-100- -PPV-A-S6
	125 mm		185299	CRDNG-125- -PPV-A-S6

CRDNG-...-S2 – Through piston rod				
	Piston diameter	Stroke	Part no.	Type
	32 mm	10 ... 2000 mm	185282	CRDNG-32- -PPV-A-S2
	40 mm		185283	CRDNG-40- -PPV-A-S2
	50 mm		185284	CRDNG-50- -PPV-A-S2
	63 mm		185285	CRDNG-63- -PPV-A-S2
	80 mm		185286	CRDNG-80- -PPV-A-S2
	100 mm		185287	CRDNG-100- -PPV-A-S2
	125 mm		185288	CRDNG-125- -PPV-A-S2

CRDNGS-...				
	Piston diameter	Stroke	Part no.	Type
	32 mm	10 ... 2000 mm	160890	CRDNGS-32- -PPV-A
	40 mm		160891	CRDNGS-40- -PPV-A
	50 mm		160892	CRDNGS-50- -PPV-A
	63 mm		160893	CRDNGS-63- -PPV-A
	80 mm		160894	CRDNGS-80- -PPV-A
	100 mm		160895	CRDNGS-100- -PPV-A
	125 mm		185281	CRDNGS-125- -PPV-A

CRDNGS-...-S6 – Heat-resistant seals up to max. 120 °C				
	Piston diameter	Stroke	Part no.	Type
	32 mm	10 ... 2000 mm	185300	CRDNGS-32- -PPV-A-S6
	40 mm		185301	CRDNGS-40- -PPV-A-S6
	50 mm		185302	CRDNGS-50- -PPV-A-S6
	63 mm		185303	CRDNGS-63- -PPV-A-S6
	80 mm		185304	CRDNGS-80- -PPV-A-S6
	100 mm		185305	CRDNGS-100- -PPV-A-S6
	125 mm		185306	CRDNGS-125- -PPV-A-S6

Peripherals

Peripherals overview

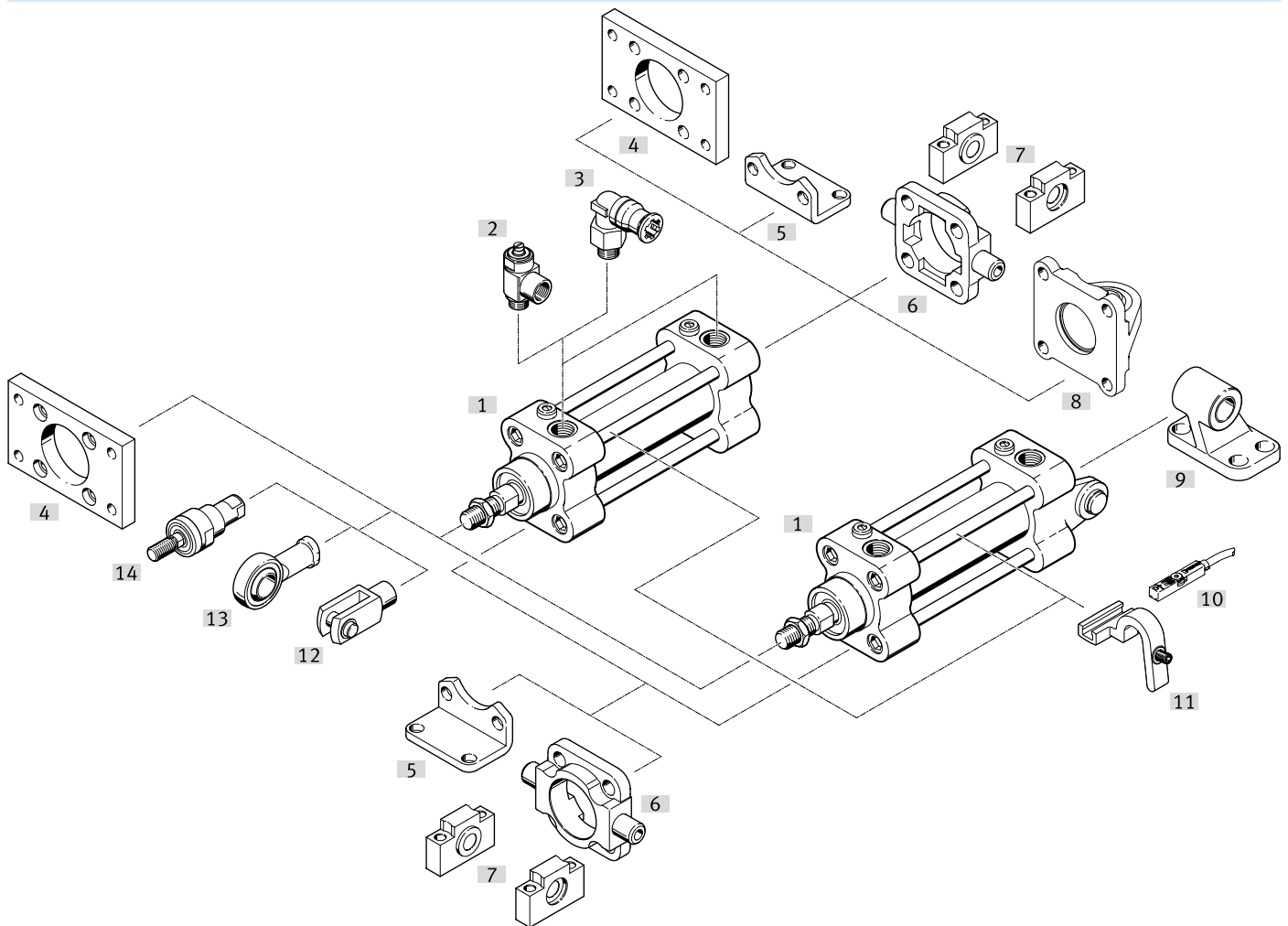

Accessories			→ Link
Type/order code		Description	
[1]	Standards-based cylinders CRDNG/S	Double-acting, based on ISO 15552, stainless steel	crdng
[2]	One-way flow control valve CRGRLA	For regulating speed	20
[3]	Push-in fitting CRQS	For connecting tubing with standard O.D.	crqs
[4]	Flange mounting CRFNG	For bearing and end caps	18
[5]	Foot mounting CRHNC	For bearing and end caps	18
[6]	Trunnion flange CRZNG	For bearing and end caps in combination with trunnion supports CRLNZG	18
[7]	Trunnion support CRLNZG	To accommodate trunnion flanges CRZNG	18
[8]	Swivel flange CRSNCS	For end caps	19
[9]	Clevis foot CRLNG	For CRDNGS (version with swivel flange)	18
[10]	Proximity switch CRSMT-8M	<ul style="list-style-type: none"> • Design for T-slot • For position sensing 	19
[11]	Mounting kit DASP-V4	For proximity switch CRSMT-8M	19
[12]	Rod clevis CRSG	Permits a swivelling movement of the cylinder in one plane	19
[13]	Rod eye CRSGS	With spherical bearing	19
[14]	Self-aligning rod coupler CRFK	To compensate for radial and angular deviations	19

Accessories

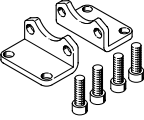
Foot mounting CRHNC					
	Description	Material mounting	Product weight	Part no.	Type
	For Ø 32	High-alloy stainless steel	139 g	176937	CRHNC-32
	For Ø 40		188 g	176938	CRHNC-40
	For Ø 50		341 g	176939	CRHNC-50
	For Ø 63		424 g	176940	CRHNC-63
	For Ø 80		810 g	176941	CRHNC-80
	For Ø 100		990 g	176942	CRHNC-100
	For Ø 125		1,920 g	176943	CRHNC-125

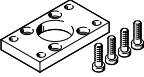
Flange mounting CRFNG					
	Description	Material mounting	Product weight	Part no.	Type
	For Ø 32	High-alloy stainless steel	220 g	161846	CRFNG-32
	For Ø 40		291 g	161847	CRFNG-40
	For Ø 50		526 g	161848	CRFNG-50
	For Ø 63		680 g	161849	CRFNG-63
	For Ø 80		1,508 g	161850	CRFNG-80
	For Ø 100		2,054 g	161851	CRFNG-100
	For Ø 125		3,787 g	185363	CRFNG-125

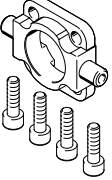
Trunnion flange CRZNG					
	Description	Material mounting	Product weight	Part no.	Type
	For Ø 32	High-alloy stainless steel	150 g	161852	CRZNG-32
	For Ø 40		285 g	161853	CRZNG-40
	For Ø 50		473 g	161854	CRZNG-50
	For Ø 63		687 g	161855	CRZNG-63
	For Ø 80		1,296 g	161856	CRZNG-80
	For Ø 100		2,254 g	161857	CRZNG-100
	For Ø 125		3,484 g	185362	CRZNG-125

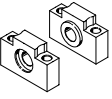
Trunnion support CRLNZG					
	Description	Material mounting	Product weight	Part no.	Type
	For Ø 32	High-alloy stainless steel	205 g	161874	CRLNZG-32
	For Ø 40, 50		323 g	161875	CRLNZG-40/50
	For Ø 63, 80		435 g	161876	CRLNZG-63/80
	For Ø 100, 125		739 g	161877	CRLNZG-100/125

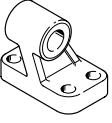
Clevis foot CRLNG					
	Description	Material mounting	Product weight	Part no.	Type
	For Ø 32	Electropolished	133 g	161840	CRLNG-32
	For Ø 40	High-alloy steel	161 g	161841	CRLNG-40
	For Ø 50		281 g	161842	CRLNG-50
	For Ø 63		370 g	161843	CRLNG-63
	For Ø 80		562 g	161844	CRLNG-80
	For Ø 100		915 g	161845	CRLNG-100
	For Ø 125		2,539 g	176951	CRLNG-125

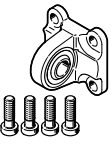
Swivel flange CRSNCS					
	Description	Material mounting	Product weight	Part no.	Type
	For Ø 32	High-alloy stainless steel	161 g	2895920	CRSNCS-32

Accessories

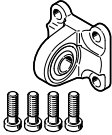
Swivel flange CRSNCS					
	Description	Material mounting	Product weight	Part no.	Type
	For Ø 40	High-alloy stainless steel	239 g	2895921	CRSNCS-40
	For Ø 50		403 g	2895922	CRSNCS-50
	For Ø 63		576 g	2895923	CRSNCS-63
	For Ø 80		1,173 g	2895924	CRSNCS-80

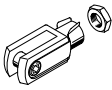
Rod clevis CRSG					
	Description	Material rod clevis	Product weight	Part no.	Type
	For Ø 32	High-alloy steel	101.8 g	13569	CRSG-M10X1,25
	For Ø 40		162.8 g	13570	CRSG-M12X1,25
	For Ø 50, For Ø 63		380.2 g	13571	CRSG-M16X1,5
	For Ø 80, For Ø 100		757.8 g	13572	CRSG-M20X1,5
	For Ø 125		2,022.1 g	185361	CRSG-M27X2

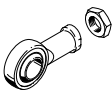
Rod eye CRSGS					
	Description	Material housing	Product weight	Part no.	Type
	For Ø 32	High-alloy steel	87 g	195582	CRSGS-M10X1,25
	For Ø 40		129 g	195583	CRSGS-M12X1,25
	For Ø 50, For Ø 63		265 g	195584	CRSGS-M16X1,5
	For Ø 80, For Ø 100		464 g	195585	CRSGS-M20X1,5
	For Ø 125		1,333 g	195586	CRSGS-M27X2

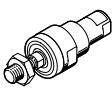
Self-aligning rod coupler CRFK					
	Description	Material housing	Product weight	Part no.	Type
	for Ø 32	High-alloy stainless steel	230 g	2305778	CRFK-M10X1,25
	for Ø 40			2305779	CRFK-M12X1,25
	for Ø 50, 63		670 g	2490673	CRFK-M16X1,5
	For Ø 80/100		1,280 g	2545677	CRFK-M20X1,5

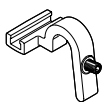
Mounting kits for proximity switches DASP					
	Description	Material retaining bracket	Product weight	Part no.	Type
	For Ø 32 ... 63	High-alloy stainless steel	28 g	8174843	DASP-V4-8-A-R1
	For Ø 80 ... 125		39 g	8174844	DASP-V4-12-A-R1

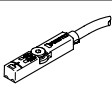
Proximity switch CRSMT-8M for T-slot, magneto-resistive						
	Type of mounting	Switching output	Electrical connection	Cable length	Part no.	Type
	Screw-clamped, insertable in the slot from above	3-wire PNP N/O contact	Open end	5 m	574380	CRSMT-8M-PS-24V-K-5,0-OE-EX2
				10 m	574381	CRSMT-8M-PS-24V-K-10,0-OE-EX2
			Plug M8, A-coded	0.3 m	574383	CRSMT-8M-PS-24V-K-0,3-M8D-EX2
					574382	CRSMT-8M-PS-24V-K-0,3-M12-EX2

Link [crsmt](#)

Accessories

Connecting cables NEBA, straight, M8 connection

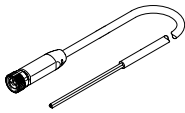
	Electrical connection 1, connector system	Electrical connection 2, connector system	Electrical connection 2, number of connections/cores	Cable length	Part no.	Type
	M8x1, A-coded, to EN 61076-2-104	Open end	3	2.5 m	★ 8078223	NEBA-M8G3-U-2.5-N-LE3
				5 m	★ 8078224	NEBA-M8G3-U-5-N-LE3

Connecting cables NEBA, straight, M12 connection

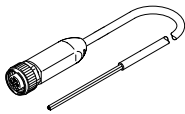
	Electrical connection 1, connector system	Electrical connection 2, connector system	Electrical connection 2, number of connections/cores	Cable length	Part no.	Type
	M12x1, A-coded to EN 61076-2-101	Open end	3	2.5 m	8078236	NEBA-M12G5-U-2.5-N-LE3
				5 m	8078237	NEBA-M12G5-U-5-N-LE3

Connecting cables NEBA, angled, M8 connection

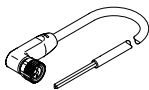
	Electrical connection 1, connector system	Electrical connection 2, connector system	Electrical connection 2, number of connections/cores	Cable length	Part no.	Type
	M8x1, A-coded, to EN 61076-2-104	Open end	3	2.5 m	★ 8078230	NEBA-M8W3-U-2.5-N-LE3
				5 m	★ 8078231	NEBA-M8W3-U-5-N-LE3

Connecting cables NEBA, angled, M12 connection

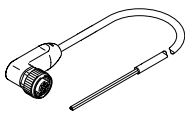
	Electrical connection 1, connector system	Electrical connection 2, connector system	Electrical connection 2, number of connections/cores	Cable length	Part no.	Type
	M12x1, A-coded to EN 61076-2-101	Open end	3	2.5 m	8078245	NEBA-M12W5-U-2.5-N-LE3
				5 m	8078246	NEBA-M12W5-U-5-N-LE3

One-way flow control valves CRGRLA

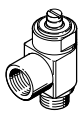
	Description	Pneumatic connection	Material swivel fitting	Product weight	Part no.	Type
	For Ø 32	G1/8	High-alloy stainless steel	37.8 g	161404	CRGRLA-1/8-B
	For Ø 40, 50	G1/4		71.6 g	161405	CRGRLA-1/4-B
	For Ø 63, 80	G3/8		126.9 g	161406	CRGRLA-3/8-B
	For Ø 100, 125	G1/2		262.3 g	161407	CRGRLA-1/2-B