

Planar surface gantries EXCM

FESTO



Key features

At a glance

General

- A gantry that is characterised by excellent functionality in compact installation spaces
- The drive concept has a low moving mass
- The kinematics are driven by 2 stepper motors with built-in optical encoders (closed loop)
- Flexible motor mounting possible

Application examples

- Feeding, pressing, joining components
- Dispensing liquid media
- Mounting electronic components

EXCM-30



EXCM-40

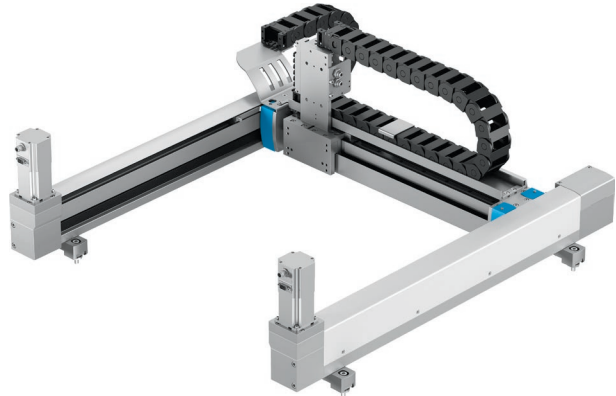

Functional principle

A slide is moved in a two-dimensional space (XY-axis) via a toothed belt. The system is powered by 2 fixed motors in position-controlled operation (closed loop). The motors are coupled to the toothed belt. The belt is guided via guide pulleys so that the slide can move to any position in a working space when the motors are actuated accordingly.

		Motor 1		
		+	•	-
Motor 2	+	→	↘	↓
	•	↗	•	↖
	-	↑	↖	←

EXCM-30

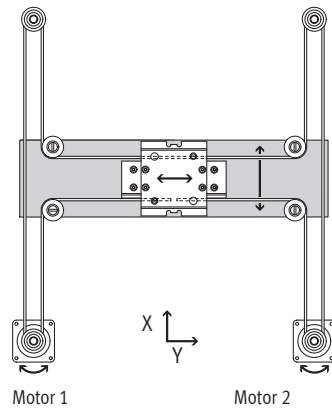

EXCM-40

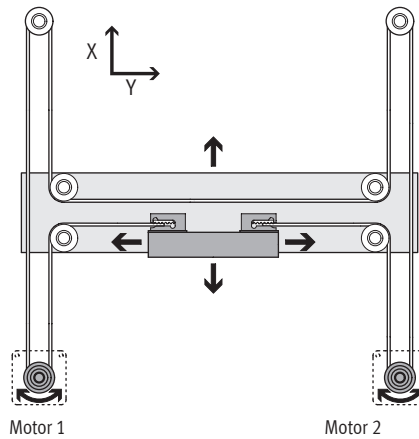

Note

Additional multi-axis controller required for interpolation (e.g. CPX-E-CEC-M1-...).

Key features

Planar surface gantry		EXCM-30	EXCM-40
Type		EXCM-30	EXCM-40
Guide		Recirculating ball bearing guide	Recirculating ball bearing guide
Stroke of the			
X-axis	[mm]	100, 150, 200, 300, 400, 500	–
		90 ... 700	200 ... 2000
Y-axis	[mm]	110, 160, 210, 260, 310, 360, 410, 460, 510	–
		110 ... 510	200 ... 1000
Rated load at max. dynamic response ¹⁾	[kg]	2/3 ²⁾	4
Repetition accuracy	[mm]	±0.05	±0.1
Installation position		Any	Horizontal
Additional technical data		→ Page 8	→ Page 22

1) Rated load = tool load (attachment components) + payload

2) Vertical/horizontal installation position. For vertical installation, we recommend consulting a sales engineer from Festo.

Key features

EXCM-30 – Motor mounting variants

Additional technical data → page 8

Below

EXCM-30-...-B1 – Cable outlet to the front

EXCM-30-...-B2 – Cable outlet to the rear

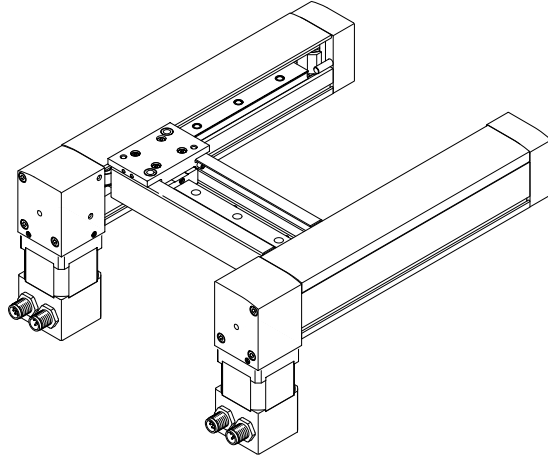
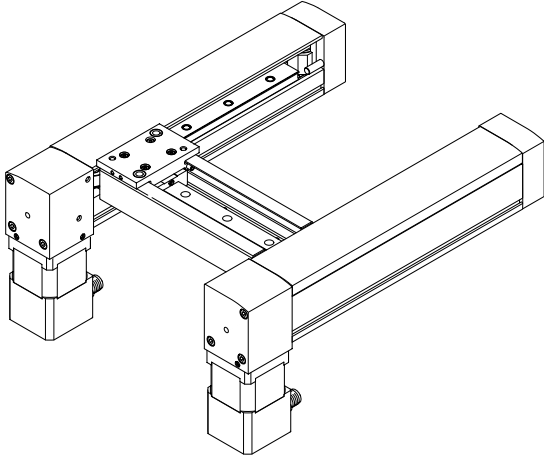

EXCM-30-...-B3 – Cable outlet on the inside

EXCM-30-...-B4 – Cable outlet on the outside

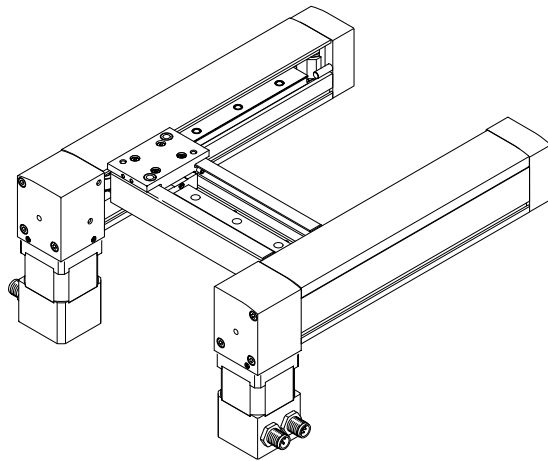
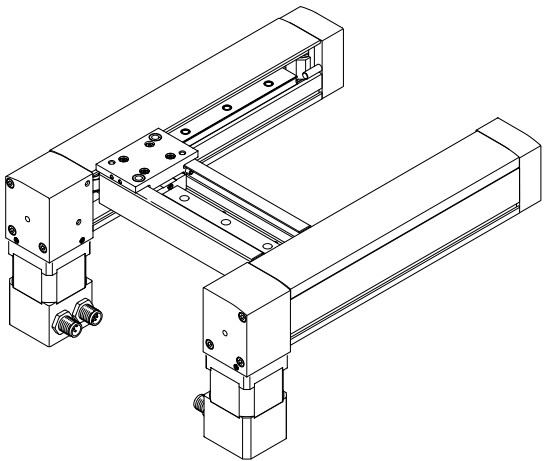

Key features

EXCM-30 – Motor mounting variants

On top

EXCM-30-...-T1 – Cable outlet to the front

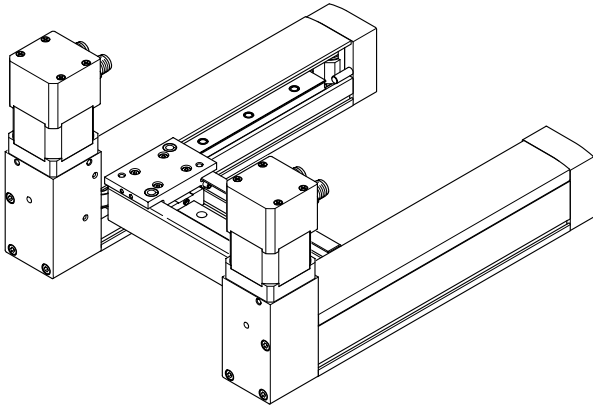

EXCM-30-...-T2 – Cable outlet to the rear

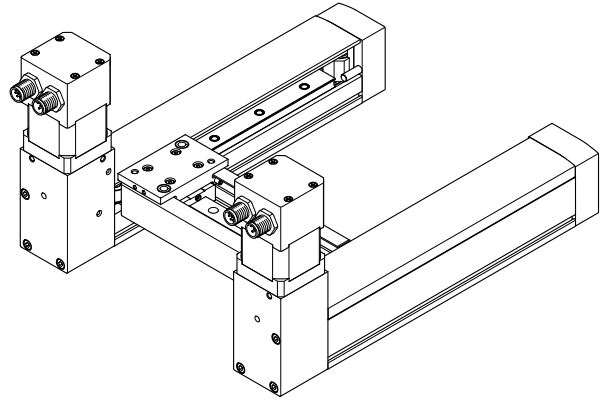

EXCM-30-...-T3 – Cable outlet on the inside

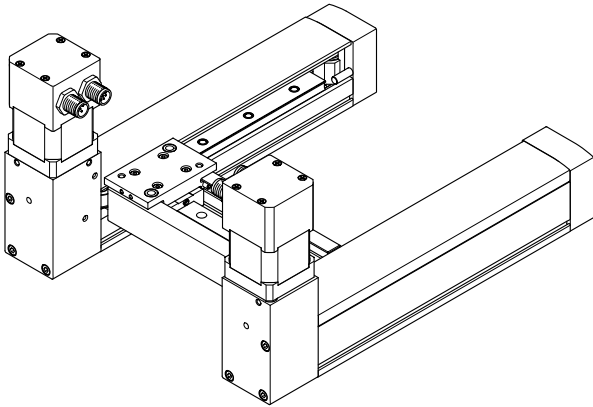

EXCM-30-...-T4 – Cable outlet on the outside

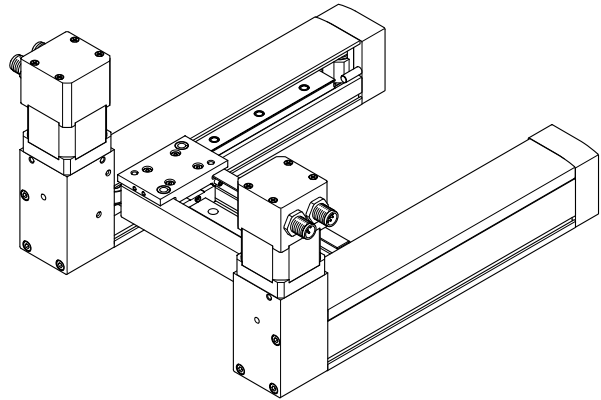

Key features

EXCM-40 – Motor mounting variants

Additional technical data → page 22

EXCM-40-...-B – Motor underneath

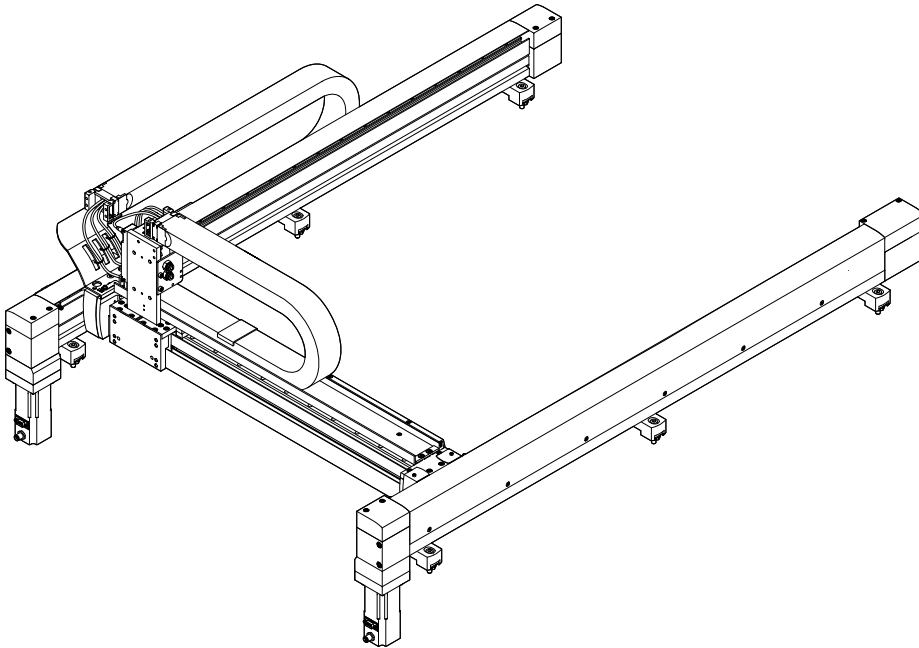

EXCM-40-...-T – Motor on top

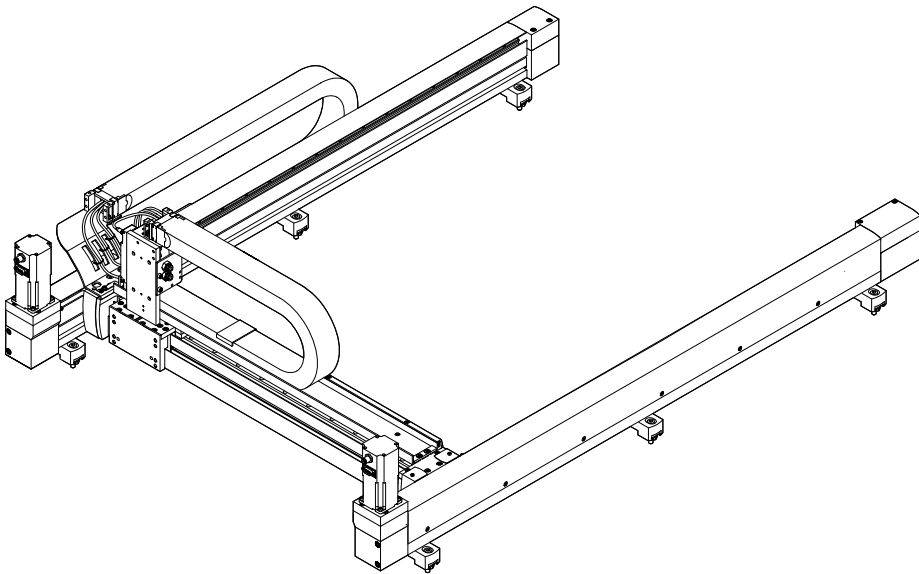

Type codes

001	Series	
EXCM	Planar surface gantry	
002	Size	
30	30	
40	40	
003	Stroke of the X-axis [mm]	
...	90 ... 2000	
004	Stroke of the Y-axis [mm]	
...	110 ... 1000	
005	Guide	
KF	Recirculating ball bearing guide	
006	Motor type	
W	Without motor	
ST	Stepper motor ST	
SB	Stepper motor ST with brake	
007	Protection against particles	
	Standard	
P8	Protected version	
008	Motor attachment position	
B	Underneath	
B1	Underneath, cable outlet at front	
B2	Underneath, cable outlet at rear	
B3	Underneath, cable outlet internal	
B4	Underneath, cable outlet external	
T	Top	
T1	Top, cable outlet at front	
T2	Top, cable outlet at rear	
T3	Top, cable outlet internal	
T4	Top, cable outlet outside	

009	Controller	
	None	
010	Cable length	
	None	
2	0.5 m	
3	1 m	
4	1.5 m	
5	2 m	
6	5 m	
7	10 m	
011	Attachment components	
	None	
012	Mounting kit	
	With mounting component	
J	With adjusting kit	
013	Document language	
DE	German	
EN	English	
ES	Spanish	
FR	French	
IT	Italian	
RU	Russian	
ZH	Chinese	
	No documentation	

Peripherals overview

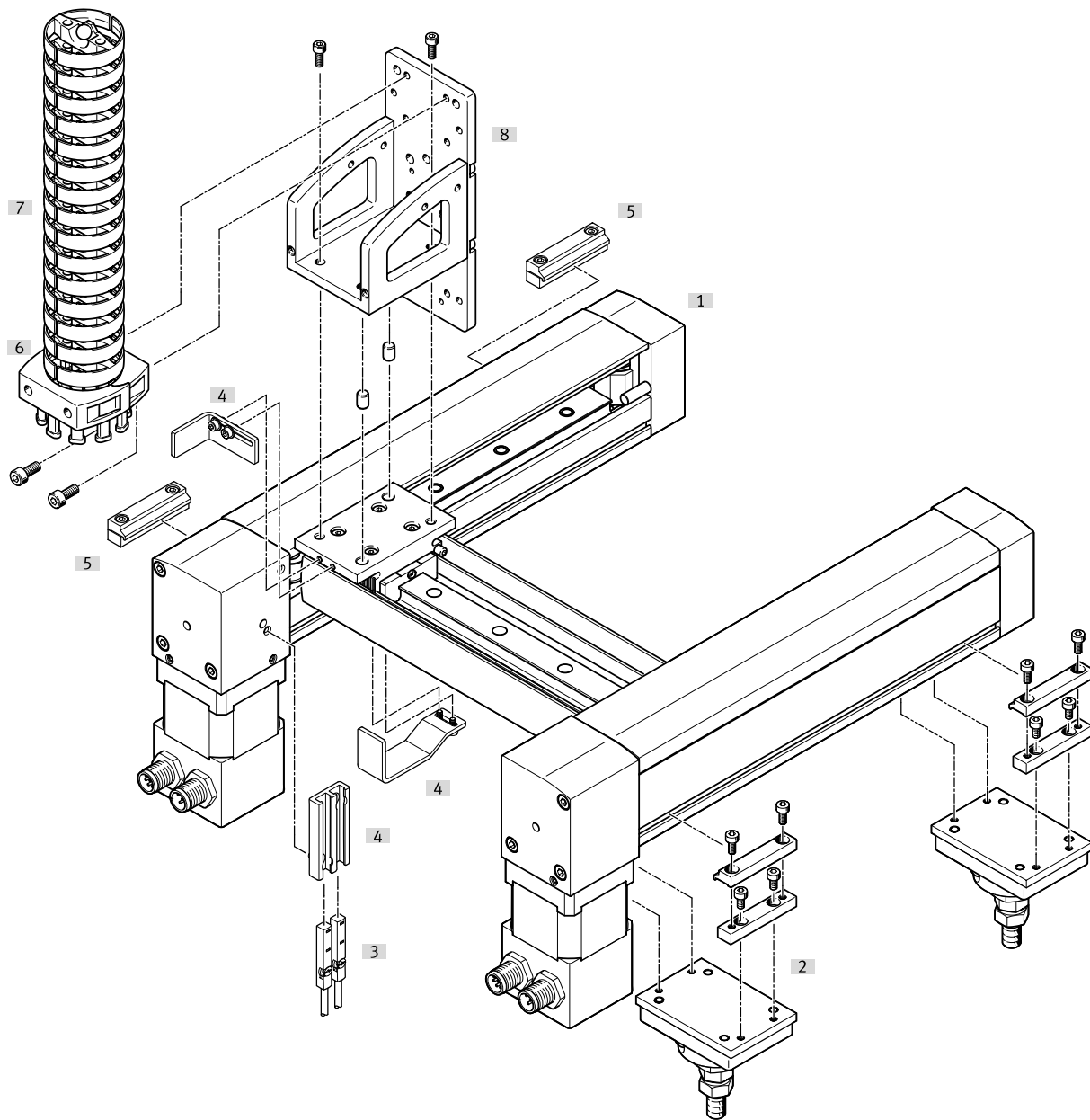

Variants and accessories

[1] With protection against particles EXCM-...-P8

The cover protects the guide of the Y-axis against contamination.

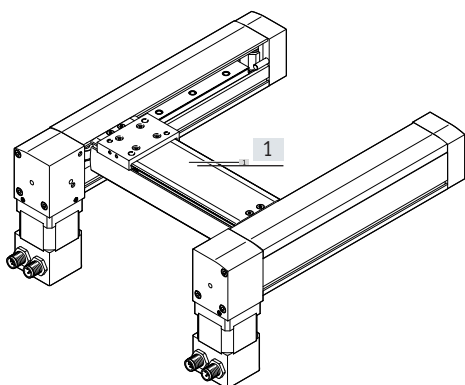

[2] With adjusting kit EADC-E11

With the adjusting kit, the gantry can be aligned after installation.

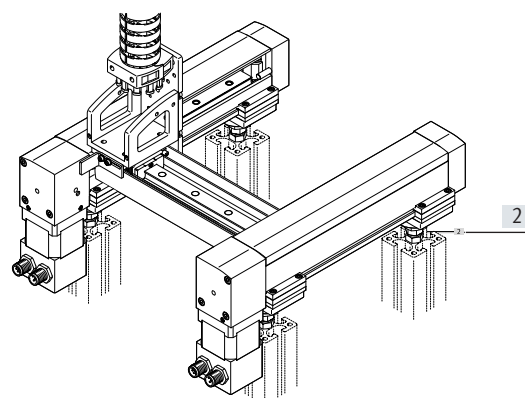

Peripherals overview

Accessories		
Type	Description	→ Page/Internet
[1] Planar surface gantry EXCM	Planar surface gantry	10
[2] Adjusting kit EADC-E11	Height-adjustable mounting kit	36
[3] Proximity switch SIES-8M	For homing in combination with third-party motors	42
[4] Sensor mounting EAPR		38
[5] Profile mounting MUE	Included in the scope of delivery of the planar surface gantry: <ul style="list-style-type: none"> • X-stroke < 500 mm: 2 pairs • X-stroke ≥ 500 mm: 3 pairs 	36
[6] Connection set	Retaining brackets for mounting the energy chain Included in the scope of delivery: <ul style="list-style-type: none"> • 2 connecting pieces • 4 socket head screws M4x10 	39
[7] Energy chain EADH-U-3D	As a cable guide for the Z-axis	39
[8] Mounting kit EAHT-E9	Mounting kit for the energy chain and a Z-axis, such as EGSL, DGSL, EGSK Stroke reduction in combination with mounting kit EAHT → page 15	37

 **Note**

Homing is always carried out using the mechanical stop in combination with the drive package from Festo; the sensor mounting and proximity switch are not required in this case.

Datasheet

General technical data

Design	Planar surface gantry	
Guide	Recirculating ball bearing guide	
Stroke of the		
X-axis	[mm]	100, 150, 200, 300, 400, 500 90 ... 700
Y-axis	[mm]	110, 160, 210, 260, 310, 360, 410, 460, 510 110 ... 510
Rated load at max. dynamic response ¹⁾	[kg]	2/3 ²⁾
Max. process force ³⁾	[N]	100
Max. torque		→ Page 12
Max. no-load torque		→ Page 12
Nominal torque of motor	[Nm]	0.5
Motor holding torque	[Nm]	0.5
Max. acceleration	[m/s ²]	20/10 ⁴⁾
Max. speed		
EXCM-...-SB-...	[m/s]	0.5
EXCM-...-ST-...	[m/s]	1.0/0.5 ⁴⁾
Repetition accuracy	[mm]	±0.05
Installation position		Any ⁵⁾
Type of mounting		
Planar surface gantry	With profile mounting	
Controller	Via H-rail, on sub-base	

1) Rated load = tool load (attachment components) + payload

2) Vertical/horizontal installation position.

3) Perpendicular to working plane, at standstill

4) In case of a load supply of 48 V/24 V

5) Motors with brake must be used in the case of vertical installation

Operating and environmental conditions

Degree of protection		IP20
Ambient temperature	[°C]	+10 ... +45
Storage temperature	[°C]	-10 ... +60
Relative humidity	[%]	0 ... 90 (non-condensing)
Noise level	[dB(A)]	52
Duty cycle	[%]	100
CE marking (see declaration of conformity)		To EU Machinery Directive

Datasheet

Materials

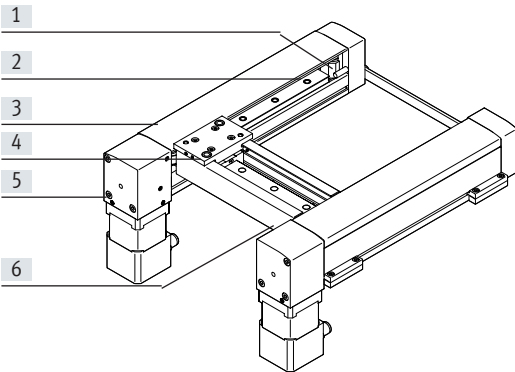

Size	30
[1] Guide pulley	Aluminium
[2] Toothed belt	Polychloroprene with glass cord
[3] Covering	
X-axis	Polymer
Y-axis	Stainless steel
[4] Slide	Aluminium
[5] End cap	Aluminium
[6] Y-axis	Aluminium
- Guide	Steel
Ball bearings	Steel
Note on materials	RoHS-compliant Contains paint-wetting impairment substances

Weight [kg]

Product weight with 0 mm stroke (without rated load, motors and controllers)	
EXCM-...	1.73
EXCM-...-P8	1.80
Y-axis (without slide)	0.34/0.4 ¹⁾
Slide of the Y-axis	0.13
Additional weight per 50 mm stroke	
X-axis	0.237
Y-axis	0.12 0/0.132 ¹⁾
Weight	
2 motors	0.9
2 motors with brake	1.5

1) Standard/with protection against particles P8

Toothed belt

Size	30
Pitch	[mm] 2
Elongation	[%] 0.14
Reference force for elongation	[N] 40
Width	[mm] 8
Effective diameter	[mm] 12.1
Feed constant ¹⁾	[mm/rev] 38

1) Feed constant at 45° travel

 **Note**
Engineering software
Handling Guide Online
www.festo.com/handling-guide

Datasheet

Acceleration a as a function of the rated load m and stroke of the Y-axis

The following data applies to a horizontal installation position and refers to the service life of the mechanical system of 3500 km. For vertical installation positions, please get in touch with your local contact at Festo.

The centre of gravity of the slide is at the height of the slide in the Z-direction and in the centre of the slide in the X-/Y-directions.

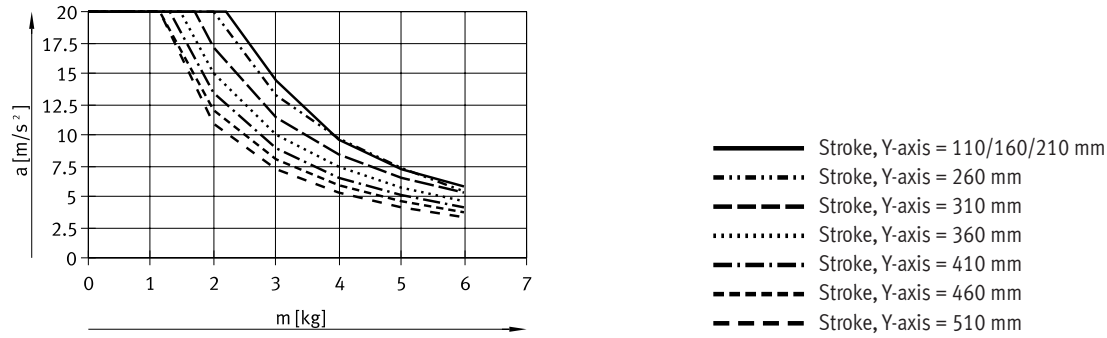

No-load torque M as a function of rotational speed n

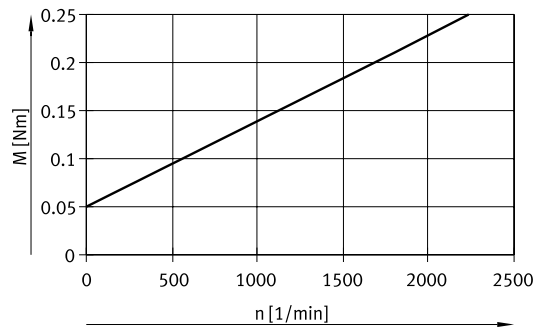

Datasheet

Load values

The centre of gravity of the slide is at the height of the slide in the Z-direction and in the centre of the slide in the X-/Y-directions.

The system is subject to the greatest load in the case of 45° travel.

The following data apply in this case:

Formula for calculating the required torque M and the required rotational speed n

$$M_{45^\circ} = a \times (4.28 \times m_L + 2.14 \times m_{Ay} + 23.38 \times J_m + 0.56) \times 10^{-3} + M_R$$

$$n_{45^\circ} = 60000 / \text{feed constant(mm)} \times \text{sqrt}(2)$$

a = acceleration [m/s²]

v = speed [m/s]

m_{Ay} = product weight of the Y-axis [kg] → page 11

m_L = attachment component (Z-axis) [kg] with payload

J_m = moment of inertia of the motor [kgcm²] → table below

M_R = no-load torque [Nm] → page 12

n_{45°} = rotational speed at 45° travel [rpm]

Combination of planar surface gantry with stepper motor for X-/Y-axis

Planar surface gantry	Motor	Moment of inertia of the motor [kgcm ²]
EXCM-30-...-ST	EMMS-ST-42-...-SE-G3	0.082
EXCM-30-...-SB	EMMS-ST-42-...-SEB-G2	0.095

Sample calculation

Assuming:

Planar surface gantry

EXCM-30-700-410-KF-ST

$$a_{\text{max}} = 10 \text{ m/s}^2$$

$$v_{\text{max}} = 2 \text{ m/s}$$

$$\text{Payload} = 0.5 \text{ kg}$$

Note
The following data applies to a horizontal installation position. For a vertical installation position, please get in touch with your local contact at Festo.
The centre of gravity of the slide is at the height of the slide in the Z-direction and in the centre of the slide in the X-/Y-directions.

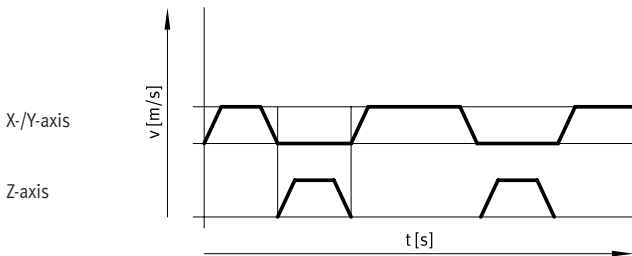

Calculation:

1. What is the max. acceleration permitted by the mechanical system?

Moving mass m_L on the Y-axis:

$$m_L = 2 \text{ kg}$$

Stroke of the Y-axis:

$$410 \text{ mm}$$

Results:

With a moving mass m_L of 2 kg, the maximum permissible acceleration is 13 m/s².

The required acceleration of 10 m/s² is thus permissible.

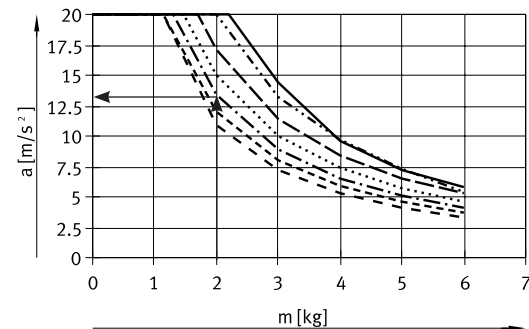

- Stroke, Y-axis = 110/160/210 mm
- Stroke, Y-axis = 260 mm
- Stroke, Y-axis = 310 mm
- Stroke, Y-axis = 360 mm
- · - · Stroke, Y-axis = 410 mm
- Stroke, Y-axis = 460 mm
- Stroke, Y-axis = 510 mm

Datasheet

Sample calculation

2. Is the attached motor sufficient for this load?

Assuming:

$$a_{\max} = 10 \text{ m/s}^2$$

$$v_{\max} = 0.35 \text{ m/s}$$

$$m_{Ay} = 1.32 \text{ kg}$$

$$m_L = 2 \text{ kg}$$

$$J_m = 0.082 \text{ kgcm}^2$$

$$M_{45^\circ} = a \times (4.28 \times m_L + 2.14 \times m_{Ay} + 23.38 \times J_m + 0.56) \times 10^{-3} + M_R$$

$$n_{45^\circ} = 60000 / \text{feed constant}(\text{mm}) \times \text{sqrt}(2)$$

a = acceleration [m/s²]

v = speed [m/s]

m_{Ay} = product weight of the Y-axis [kg] → page 11

m_L = attachment component (Z-axis) [kg] with payload

J_m = moment of inertia of the motor [kgcm²] → table below

M_R = no-load torque [Nm] → page 12

n_{45°} = nominal rotational speed at 45° travel [rpm]

Note
These requirements for the dynamic response apply to 45° travel. The dynamic values may be higher for travel only in the X- or Y-direction.

Determining M_{45°}

$$n_{45^\circ} = 60000 / \text{feed constant}(\text{mm}) \times \text{sqrt}(2)$$

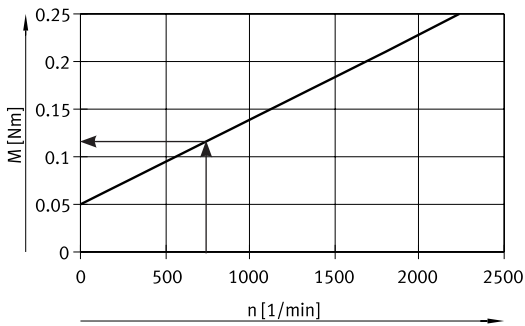

No-load torque:
— EXCM-30

$$M_R = 0.12 \text{ Nm}$$

$$M_{45^\circ} = a \times (4.28 \times m_L + 2.14 \times m_{Ay} + 23.38 \times J_m + 0.56) \times 10^{-3} + M_R$$

$$M_{45^\circ} = 10 \text{ m/s}^2 \times (4.28 \times 2 \text{ kg} + 2.14 \times 1.32 \text{ kg} + 23.38 \times 0.082 \text{ kgcm}^2 + 0.56) \times 10^{-3} + 0.12 \text{ Nm} = 0.26 \text{ Nm}$$

Results:

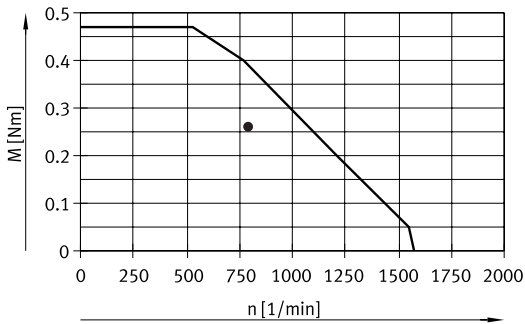

The torque value lies below the motor characteristic curve.

The design is thus acceptable.

Datasheet

Minimum number of profile mountings

Depending on the installation position and the stroke of the X-axis, a different number of profile mountings is required.

Horizontal installation position
Stroke < 500 mm

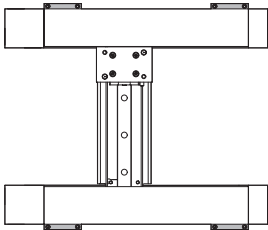

Stroke ≥ 500 mm

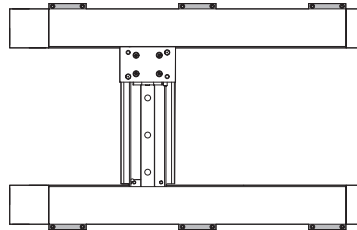

Vertical installation position
Stroke < 500 mm

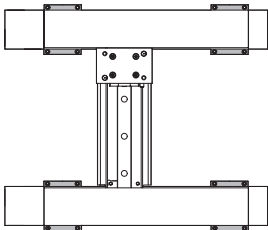

Stroke ≥ 500 mm

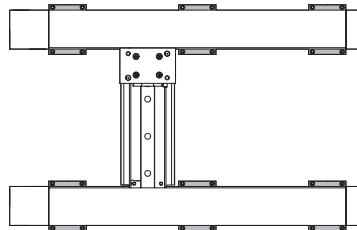

Stroke of the X-axis [mm]	Number of profile mountings	
	Horizontal installation position	Vertical installation position
100 ... 499	2 per profile, inside or outside	4 per profile, inside and outside
500 ... 700	3 per profile, inside or outside	6 per profile, inside and outside

Stroke reduction in combination with mounting kit EAHT-E9

The reduction is influenced by the following factors:

- [1] The mounting kit EAHT-E9 is wider than the slide of the Y-axis
- [2] By adjusting kits EADC-E11 or profile mountings MUE that are mounted on the inside of the X-axis
- [3] When using an additional mounting surface for the cover in combination with EXCM-...-P8 (with protection against particles)

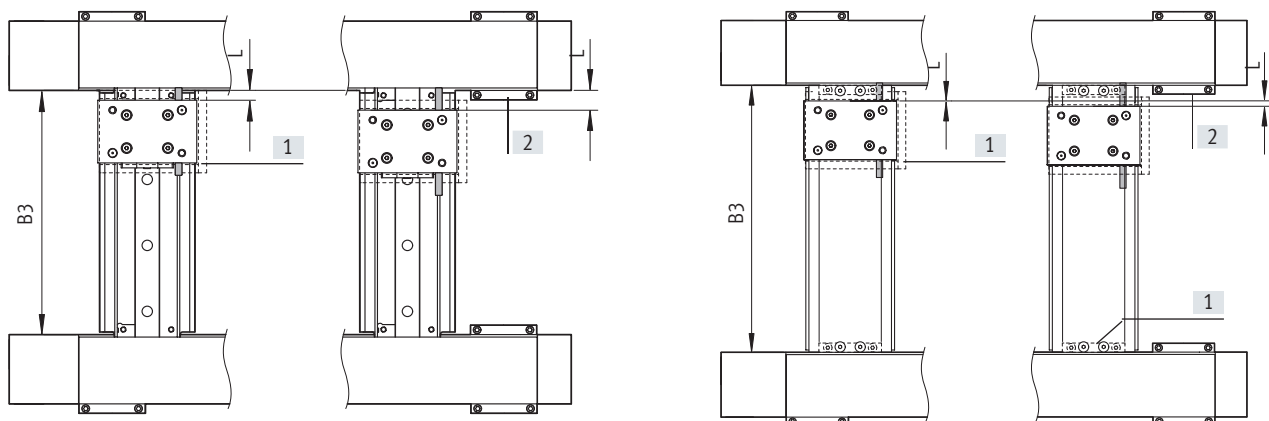

	B3 (→ from page 16)		L	
	For EXCM-...	For EXCM-...-P8	For EXCM-...	For EXCM-...-P8
With mounting kit EAHT-E9	38 + stroke	63 + stroke	2x 8 mm	No stroke reduction
With mounting kit EAHT-E9 and adjusting kits EADC-E11/ profile mountings MUE			2x 16 mm	2x 4 mm

Datasheet

Dimensions

Download CAD data → www.festo.com

EXCM-30-... and EXCM-30-...-P8

Motor attachment position – Underneath

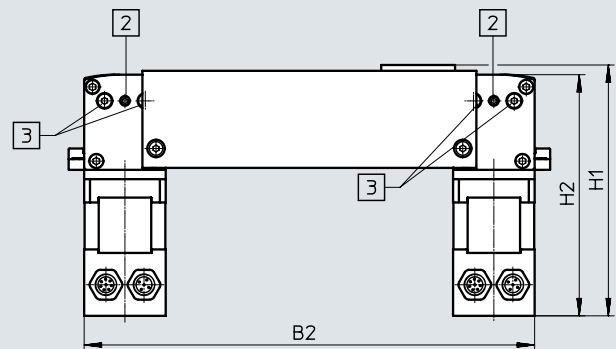
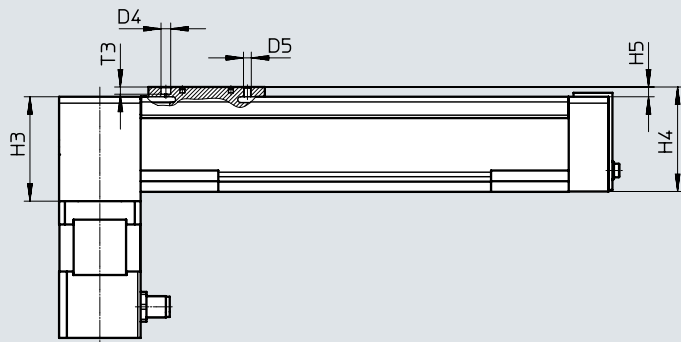
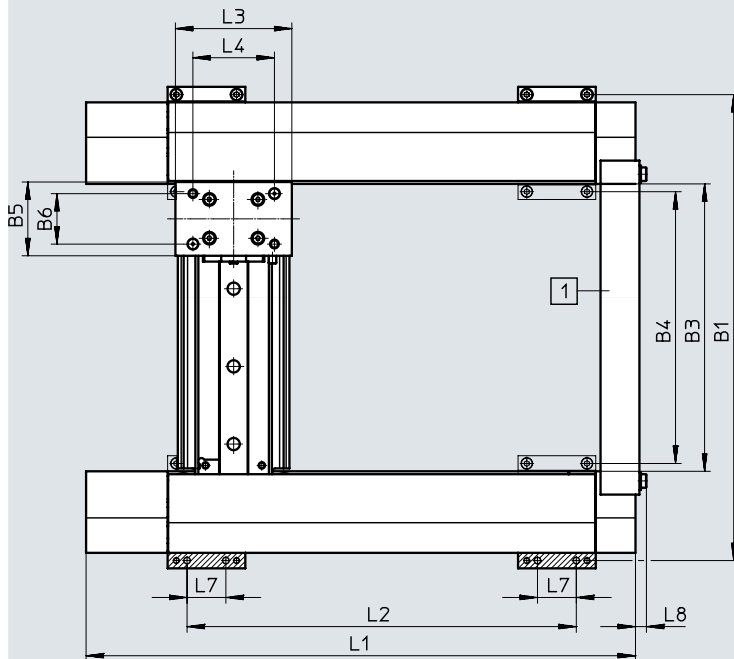

- [1] Transport lock serves as transport aid and can be removed after assembly
- [2] Threaded pin for securing the adjusting screws
- [3] Screw for setting the toothed belt tension

Datasheet

Type	B5	B6 ±0.03	B7	B8 ±0.1	D1 ∅ H7	D2 ∅	D3 ∅ f8	D4 ∅ H8	D5
EXCM-30-...	38	26	42	31	22	16	5	5	M4
EXCM-30-...-P8	38	26	42	31	22	16	5	5	M4

Type	H1		H2		H3	H4	H5	L3	L4 ±0.03
	EXCM-...-ST	EXCM-...-SB	EXCM-...-ST ±0.7	EXCM-...-SB					
EXCM-30-...	129.2	186.2	124.2	181.2	53.8	54	5	60	42
EXCM-30-...-P8	131.2	188.2	124.2	181.2	53.8	56	7	60	42

Type	L5	L6 ±0.1	L7	L8	T1	T2	T3	T4	T5
EXCM-30-...	42	31	20	5.6	3	26	3.7	28.7	24.5
EXCM-30-...-P8	42	31	20	5.6	3	26	3.7	28.7	24.5

Stroke-dependent dimensions		
Stroke of the X-axis	L1	L2 ±0.2
100	233	150.5
150	283	200.5
200	333	250.5
300	433	350.5
400	533	450.5
500	633	550.5
90 ... 700	133 + stroke	50.5 + stroke

Stroke of the Y-axis	B1		B2		B3		B4	
	EXCM-30-...-		EXCM-30-...-		EXCM-30-...-		EXCM-30-...-	
		P8		P8		P8		P8
110	240	265	232	257	148	173	140	165
160	290	315	282	307	198	223	190	215
210	340	365	332	357	248	273	240	265
260	390	415	382	407	298	323	290	315
310	440	465	432	457	348	373	340	365
360	490	515	482	507	398	423	390	415
410	540	565	532	557	448	473	440	465
460	590	615	582	607	498	523	490	515
510	640	665	632	657	548	573	540	565
110 ... 510	130 + stroke	155 + stroke	122 + stroke	147 + stroke	38 + stroke	63 + stroke	30 + stroke	55 + stroke

Datasheet

Dimensions

Download CAD data → www.festo.com

EXCM-30-... and EXCM-30-...-P8

Motor attachment position – On top

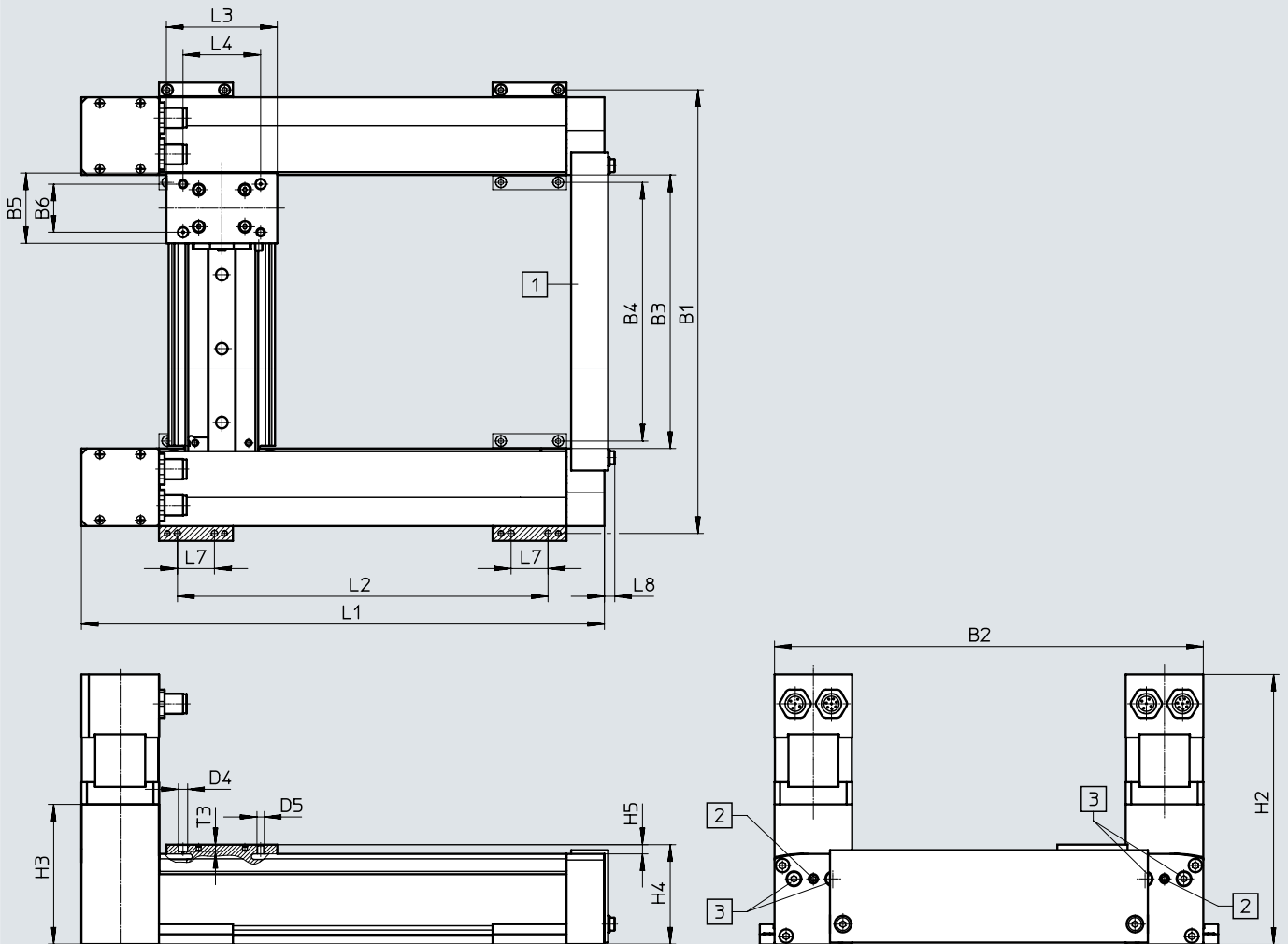

- [1] Transport lock serves as transport aid and can be removed after assembly
- [2] Threaded pin for securing the adjusting screws
- [3] Screw for setting the toothed belt tension

Datasheet

Type	B5	B6 ±0.03	B7	B8 ±0.1	D1 ∅ H7	D2 ∅	D3 ∅ f8	D4 ∅ H8
EXCM-30-...	38	26	42	31	22	16	5	5
EXCM-30-...-P8	38	26	42	31	22	16	5	5

Type	D5	H2		H3	H4	H5	L3	L4 ±0.03
		EXCM-...-ST ±1	EXCM-...-SB					
EXCM-30-...	M4	146.2	203.2	75.6	54	5	60	42
EXCM-30-...-P8	M4	146.2	203.2	75.6	56	7	60	42

Type	L5	L6 ±0.1	L7	L8	T1	T2	T3	T4	T5
EXCM-30-...	42	31	20	5.6	3	26	3.7	28.7	24.5
EXCM-30-...-P8	42	31	20	5.6	3	26	3.7	28.7	24.5

Stroke-dependent dimensions		
Stroke of the X-axis	L1	L2 ±0.2
100	233	150.5
150	283	200.5
200	333	250.5
300	433	350.5
400	533	450.5
500	633	550.5
90 ... 700	133 + stroke	50.5 + stroke

Stroke of the Y-axis	B1		B2		B3		B4	
	EXCM-30-...-		EXCM-30-...-		EXCM-30-...-		EXCM-30-...-	
		P8		P8		P8		P8
110	240	265	232	257	148	173	140	165
160	290	315	282	307	198	223	190	215
210	340	365	332	357	248	273	240	265
260	390	415	382	407	298	323	290	315
310	440	465	432	457	348	373	340	365
360	490	515	482	507	398	423	390	415
410	540	565	532	557	448	473	440	465
460	590	615	582	607	498	523	490	515
510	640	665	632	657	548	573	540	565
110 ... 510	130 + stroke	155 + stroke	122 + stroke	147 + stroke	38 + stroke	63 + stroke	30 + stroke	55 + stroke

Datasheet

Dimensions

Download CAD data → www.festo.com

EXCM-30-... and EXCM-30-...-P8

Motor interface

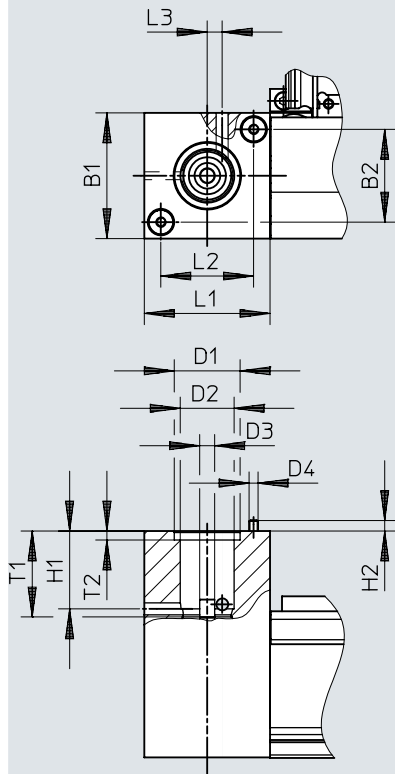

Type	B1	B2	D1	D2	D3	D4	H1
EXCM-30-...	42	31 ±0.1	22 ∅ H7	16 ∅	5 ∅ f8	M3	26

Type	H2	L1	L2	L3	T1	T2
EXCM-30-...	3.6	42	31 ±0.1	5	28.7	3

Ordering data – Modular product system

Ordering table		30	Conditions	Code	Enter code
Size		30			
Module no.		2226101			
Product type		EXCM series M		EXCM	EXCM
Size		30		-30	30
Stroke of the X-axis	[mm]	100		-100	
	[mm]	150		-150	
	[mm]	200		-200	
	[mm]	300		-300	
	[mm]	400		-400	
	[mm]	500		-500	
	[mm]	90 ... 700		-...	
Stroke of the Y-axis	[mm]	110		-110	
	[mm]	160		-160	
	[mm]	210		-210	
	[mm]	260		-260	
	[mm]	310		-310	
	[mm]	360		-360	
	[mm]	410		-410	
	[mm]	460		-460	
	[mm]	510		-510	
	[mm]	110 ... 510		-...	
Guide		Recirculating ball bearing guide		-KF	KF
Motor type		Stepper motors		-ST	
		Stepper motors with brake		-SB	
		Without stepper motors		-W	
Protection against particles		Standard			
		Protected version		-P8	
Motor attachment position		Underneath	[1]	-B	
		Underneath, cable outlets to the front		-B1	
		Underneath, cable outlets to the rear		-B2	
		Underneath, cable outlets on the inside		-B3	
		Underneath, cable outlets on the outside		-B4	
		On top	[1]	-T	
		On top, cable outlets to the front		-T1	
		On top, cable outlets to the rear		-T2	
		On top, cable outlets on the inside		-T3	
	On top, cable outlets on the outside		-T4		
Controller		None			
Cable length		None			
		Motor and encoder cable 0.5 m		2	
		Motor and encoder cable 1 m		3	
		Motor and encoder cable 1.5 m		4	
		Motor and encoder cable 2 m		5	
Document language		German		-DE	
		English		-EN	
		Spanish		-ES	
		French		-FR	
		Italian		-IT	
		Russian		-RU	
	Chinese		-ZH		

[1] B, T Not in combination with stepper motors ST and SB. Option if third-party motors are mounted

Peripherals overview

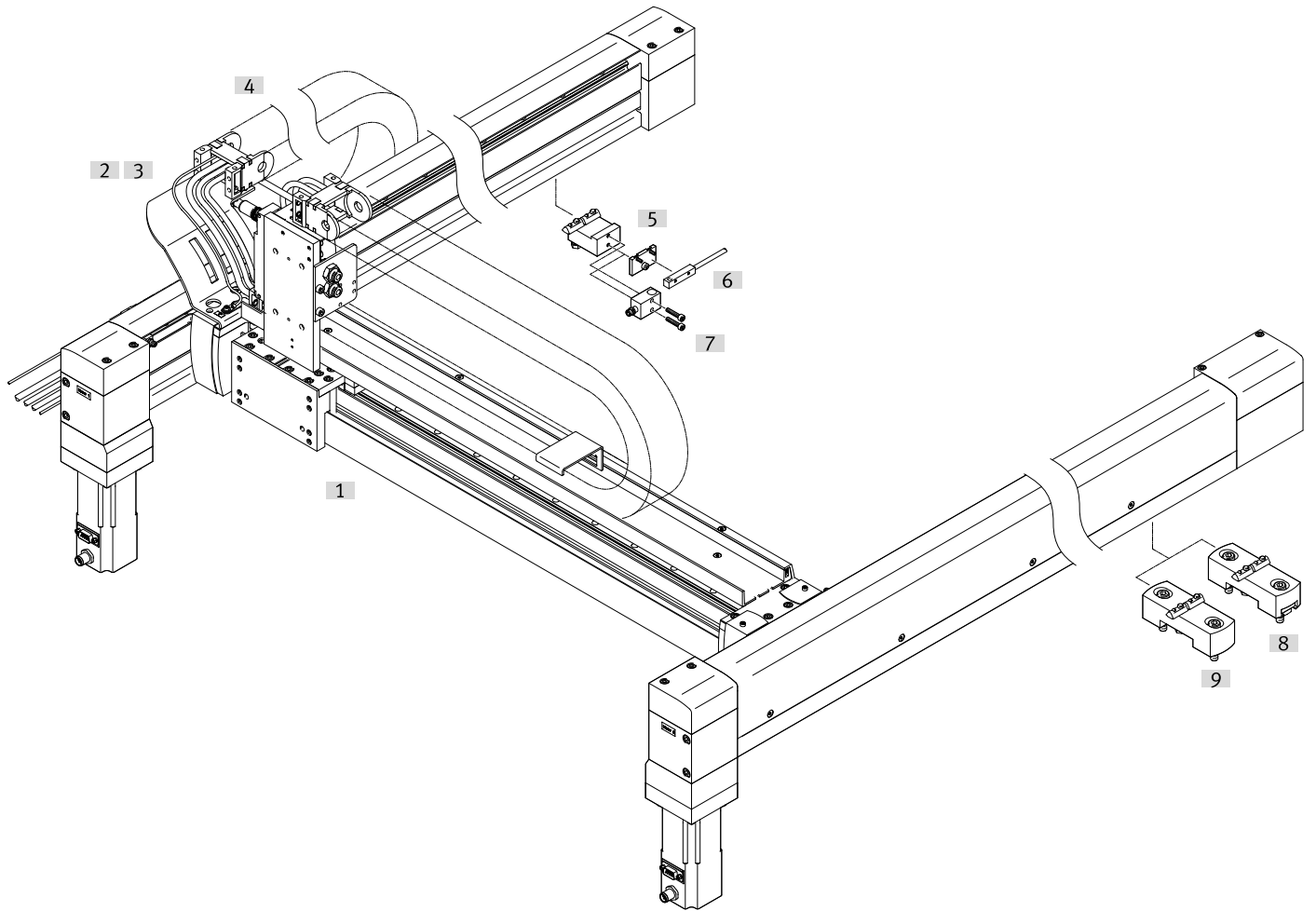

Proximity switch for sensing the position of the slide on the Y-axis

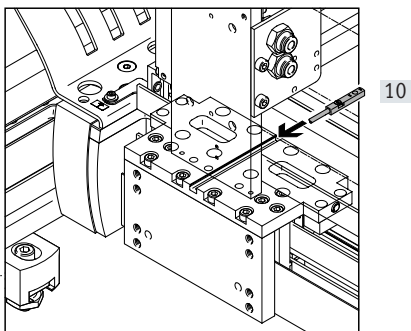

Peripherals overview

Attachments and accessories			→ Page/Internet
Type	Description		
[1] Planar surface gantry EXCM	Planar surface gantry		24
[2] Multi-pin plug distributor NEDU	<ul style="list-style-type: none"> For connecting up to 6 inputs/outputs Included in the scope of delivery of the planar surface gantry 		nedu
[3] Plug socket with cable SIM	<ul style="list-style-type: none"> Connecting cable between multi-pin plug distributor NEDU and the controller Included in the scope of delivery of the planar surface gantry 		sim
[4] Energy chain	<ul style="list-style-type: none"> For EXCM-40: type IGUS 2500.03.075.0 		–
[5] Sensor mounting EAPR	<ul style="list-style-type: none"> For mounting the proximity switches SIES-Q8B, SIES-V3B on the X-axis Not included in the scope of delivery of the planar surface gantry 		41
[6] Proximity switch SIES-Q8B	<ul style="list-style-type: none"> For position sensing on the X-axis Not included in the scope of delivery of the planar surface gantry 		42
[7] Proximity switch SIES-V3B	<ul style="list-style-type: none"> For position sensing on the X-axis Not included in the scope of delivery of the planar surface gantry 		42
[8] Adjusting kit EADC-12	<ul style="list-style-type: none"> Height-adjustable mounting kit for the planar surface gantry Included in the scope of delivery of the planar surface gantry. If no adjusting kit is selected in the modular product system, the mounting kit will automatically be delivered 		40
[9] Mounting kit EAHM-E12	<ul style="list-style-type: none"> Non-height-adjustable mounting kit for the planar surface gantry 		40
[10] Proximity switch SIES-8M	<ul style="list-style-type: none"> For position sensing on the Y-axis Not included in the scope of delivery of the planar surface gantry 		42
– Plastic tubing PUN-H-6x1	<ul style="list-style-type: none"> Two pieces of tubing are connected to the bulkhead fittings and routed in the energy chains on delivery (for pneumatic Z-axis, one tube on the valve and one on the bulkhead fitting) 		pun

Selection of attachment components

The gantry is delivered as standard in the configuration without attachment elements.

The "Handling Guide Online" engineering software can be used to configure the planar surface gantry with other attachment components, such as a pneumatic or electric Z-axis.

EXCM-... (without attachment component)

The following are pre-installed:

- 2 supply ports for e.g. Z-axis
- Multi-pin plug distributor for bundling signals:
 - e.g. proximity switch

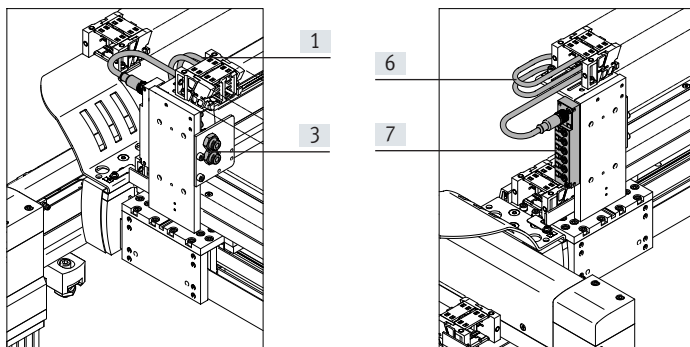

Components	Number of components
[1] Tubing	2
[3] Bulkhead fitting	2
[6] Plug socket with cable	1
[7] Multi-pin plug distributor (6-way)	1
– Earthing cable	2

Datasheet

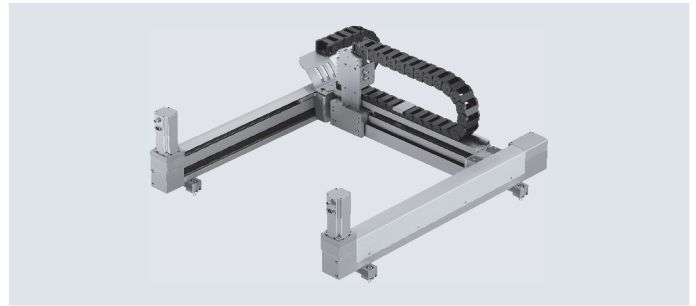
General technical data

Design	Planar surface gantry	
Guide	Recirculating ball bearing guide	
Stroke of the		
X-axis	[mm]	200 ... 2000
Y-axis	[mm]	200 ... 1000
Rated load at max. dynamic response ¹⁾	[kg]	4
Process force in Z direction	[N]	450
Max. no-load torque ²⁾³⁾	→ Page 27	
Max. acceleration ⁴⁾		
Purely mechanical system	[m/s ²]	20
Max. speed ⁴⁾		
With motor	[m/s]	1
Purely mechanical system	[m/s]	2
Repetition accuracy	[mm]	±0.1
Installation position	Horizontal	
Type of mounting	Mounting kit, adjusting kit	

1) Rated load = tool load (attachment component (Z-axis) + e.g. gripper) + payload

2) These values must also be complied with when installing third-party motors

3) At v=0.2 m/s and 45° travel.

4) This data applies only under ideal conditions.

For a precise configuration, please consult a sales engineer from Festo.

Additional information → page 27

Operating and environmental conditions

Degree of protection	IP40	
Ambient temperature ¹⁾	[°C]	+10 ... +50
Storage temperature	[°C]	-10 ... +60
Relative humidity	[%]	0 ... 90 (non-condensing)
Noise level	[dB(A)]	65
Duty cycle	[%]	100
CE marking (see declaration of conformity)	To EU Machinery Directive	

1) Note operating range of proximity switches and motors

Datasheet

Materials

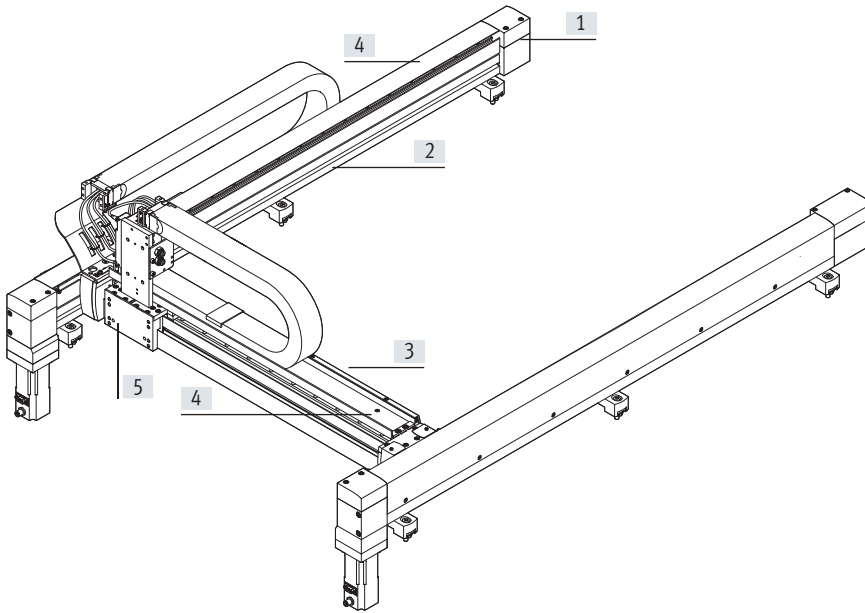

Size	40
[1] Drive and end caps	Aluminium
[2] Profiles of the X-axis	Aluminium
[3] Profile of the Y-axis	Aluminium
[4] Covering	
X-axis	Aluminium
Y-axis	Aluminium
[5] Slide	Aluminium
– Coupling	Aluminium with elastomer ring gear
Guide	Steel
Drive pinion	Steel
Ball bearings	Steel
Toothed belt	PU with steel cord
Note on materials	RoHS-compliant
	Contains paint-wetting impairment substances

Datasheet

Weight [kg]	
Product weight at 0 mm stroke (without rated load, motors, axial kits, mounting kits)	
EXCM-...-W-T	16.7
EXCM-...-W-B	17.5
X-axis (2x)	8.5
Y-axis (without slide)	6.2
Slide of the Y-axis	1.5
Additional weight per 100 mm stroke	
X-axis	1.75
Y-axis	0.89
Axial kit ¹⁾	
For EMMS-ST-57-M	0.54
Motor ¹⁾	
EXCM-...-ST (without brake)	1.2
EXCM-...-SB (with brake)	1.38
Mounting kit for X-axis	
Adjusting kit ¹⁾	0.78
Mounting kit ¹⁾	0.33

1) Weight per component

Toothed belt		
Size		40
Pitch	[mm]	3
Elongation	[%]	0.04
Reference force for elongation	[N]	80
Width	[mm]	20
Effective diameter	[mm]	27.69
Feed constant ¹⁾	[mm/rev]	87

1) Feed constant at 45° travel

 **Note**

Engineering software
 Handling Guide Online
www.festo.com/handling-guide

Datasheet

No-load torque M as a function of rotational speed n

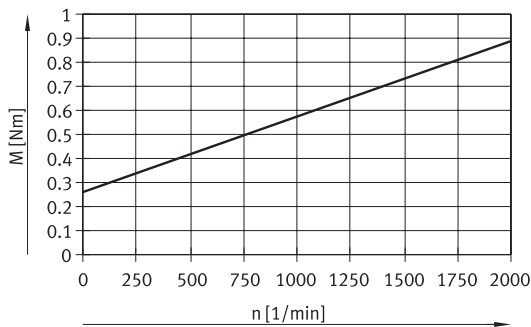

Load values

The centre of gravity of the slide is at the height of the slide in the Z-direction and in the centre of the slide in the X-/Y-directions.

The system is subject to the greatest load in the case of 45° travel.

The following data apply in this case:

Formula for calculating the required torque M and the required rotational speed n

$$M_{45^\circ} = a \times (9.79 \times m_L + 4.89 \times m_{Ay} + 10.21 \times J_m + 19.58) \times 10^{-3} + M_R$$

$$n_{45^\circ} = 60000 / \text{feed constant(mm)} \times \text{sqrt}(2)$$

a = acceleration [m/s²]

v = speed [m/s]

m_{Ay} = product weight of the Y-axis [kg] → page 26

m_L = attachment component (Z-axis) [kg] with payload

J_m = moment of inertia of the motor [kgcm²] → table below

M_R = no-load torque [Nm] → page 27

n_{45° = nominal rotational speed at 45° travel [rpm]

Allocation of planar surface gantry to servo motor for X-/Y-axis

Planar surface gantry	Motor	Moment of inertia of the motor [kgcm ²]
EXCM-40-...-ST	EMMS-ST-57-M-SE-G2	0.48
EXCM-40-...-SB	EMMS-ST-57-M-SEB-G2	0.5

Datasheet

Sample calculation

Assuming:

Planar surface gantry

EXCM-40-1000-500-KF-SB-B-PF7-HE1-...

with attached motor

EMMS-ST-57-M-SEB-G2

$$a_{\max} = 2 \text{ m/s}^2$$

$$v_{\max} = 0.5 \text{ m/s}$$

$$\text{Payload} = 0.5 \text{ kg}$$

Attachment component on Z-axis: EGSL-BS-45-100-10P

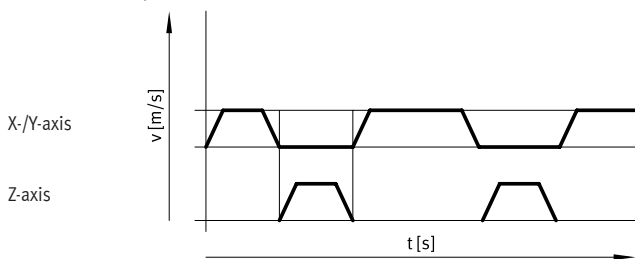

Sample calculation

2. Is the attached motor sufficient for this load?

Assuming:

$$a_{\max} = 2 \text{ m/s}^2$$

$$v_{\max} = 0.5 \text{ m/s}$$

$$m_{Ay} = 10.65 \text{ kg}$$

$$m_L = 3.8 \text{ kg}$$

$$J_m = 0.5 \text{ kgcm}^2$$

$$M_{45^\circ} = a \times (9.79 \times m_L + 4.89 \times m_{Ay} + 10.21 \times J_m + 19.58) \times 10^{-3} + M_R$$

$$n_{45^\circ} = 60000 / \text{feed constant(mm)} \times \text{sqrt}(2)$$

a = acceleration [m/s²]

v = speed [m/s]

m_{Ay} = product weight of the Y-axis [kg] → page 26

m_L = attachment component (Z-axis) [kg] with payload

J_m = moment of inertia of the motor [kgcm²] → table below

M_R = no-load torque [Nm] → page 27

n_{45° = nominal rotational speed at 45° travel [rpm]

Note

These requirements for the dynamic response apply to 45° travel. The dynamic values may be higher for travel only in the X- or Y-direction.

Datasheet

Sample calculation

Determining M_{45°

$$n_{45^\circ} = 60000 / \text{feed constant(mm)} \times \text{sqrt}(2)$$

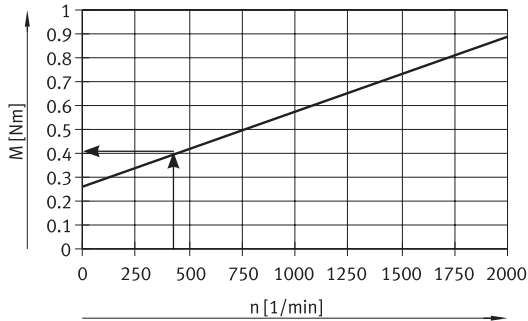

No-load torque:
 EXCM-40

$$M_R = 0.4 \text{ Nm}$$

$$M_{45^\circ} = a \times (9.79 \times m_l + 4.89 \times m_{Ay} + 10.21 \times J_m + 19.58) \times 10^{-3} + M_R$$

$$M_{45^\circ} = 2 \text{ m/s}^2 \times (9.79 \times 3.8 \text{ kg} + 4.89 \times 10.65 \text{ kg} + 10.21 \times 0.5 \text{ kg cm}^2 + 19.58) \times 10^{-3} + 0.4 \text{ Nm} = 0.63 \text{ Nm}$$

Results:

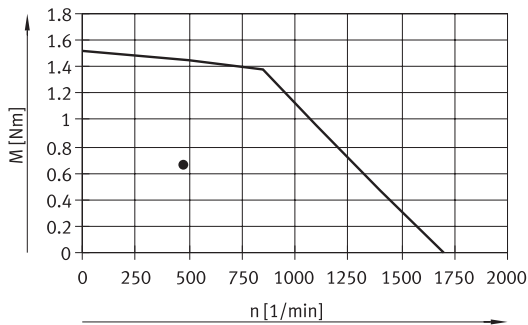

The torque value lies below the motor characteristic curve.

The design is thus acceptable.

Datasheet

Minimum number of profile mountings

Irrespective of the installation position, a different number of profile mountings needs to be used depending on the stroke of the X-axis.
The required number is mounted on delivery.

Stroke of the X-axis [mm]	Number of profile mountings per axis
200 ... 499	2
500 ... 899	2
900 ... 1799	3
1800 ... 2000	4

Distances between the profile mountings

The profile mountings must be evenly spaced by distance l .

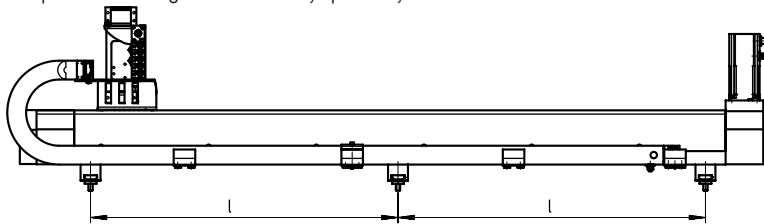

$$l_1 = \frac{l + 141}{n - 1}$$

l_1 = distance

l = stroke

n = number of profile mountings per axis

Installation position of attachment components

Due to manufacturing tolerances and the backlash in the guides, the angle between the mounting plane and the attachment component, e.g. Z-axis, may not be exactly 90° in certain circumstances.

Max. deviation:

$$\hat{\alpha} = \pm 1.1^\circ$$

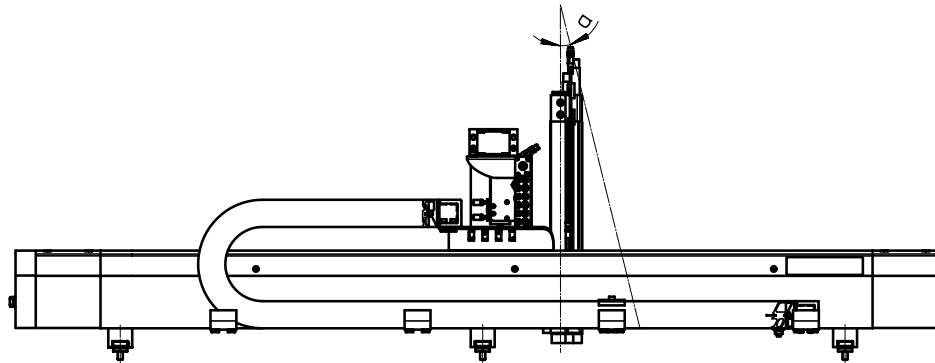

Datasheet

Pin allocations

Motors on the X-/Y-axis

Motor

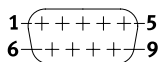

Encoder

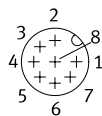

PIN	Function
1	String A
2	String A/
3	String B
4	String B/
5	n. c.
6	n. c.
7	Brake (24 V)
8	Brake (0 V)
9	-

PIN	Function
1	Signal trace A
2	Signal trace A/
3	Signal trace B
4	Signal trace B/
5	0 V
6	Signal trace N
7	Signal trace N/
8	5 V

Selection of cable lengths

2 cable lengths (5 m or 10 m) can be selected using the modular product system → page 34. This specification relates to the output of the energy chain at the X-axis (dimension L) and describes the minimum length by which the cables and tubing protrude. The selected length applies to the following components:

- Tubing
- Plug sockets with cable

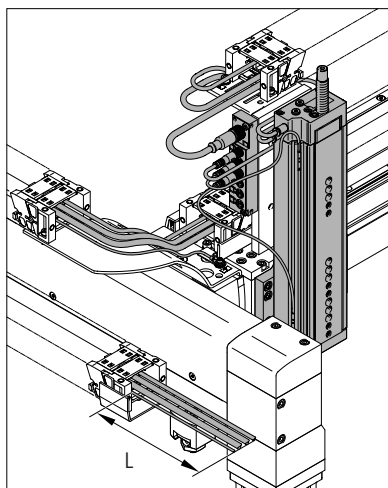

Sample product image

Datasheet

Dimensions

Download CAD data → www.festo.com

EXCM-40-...-T – Motor attachment position on top

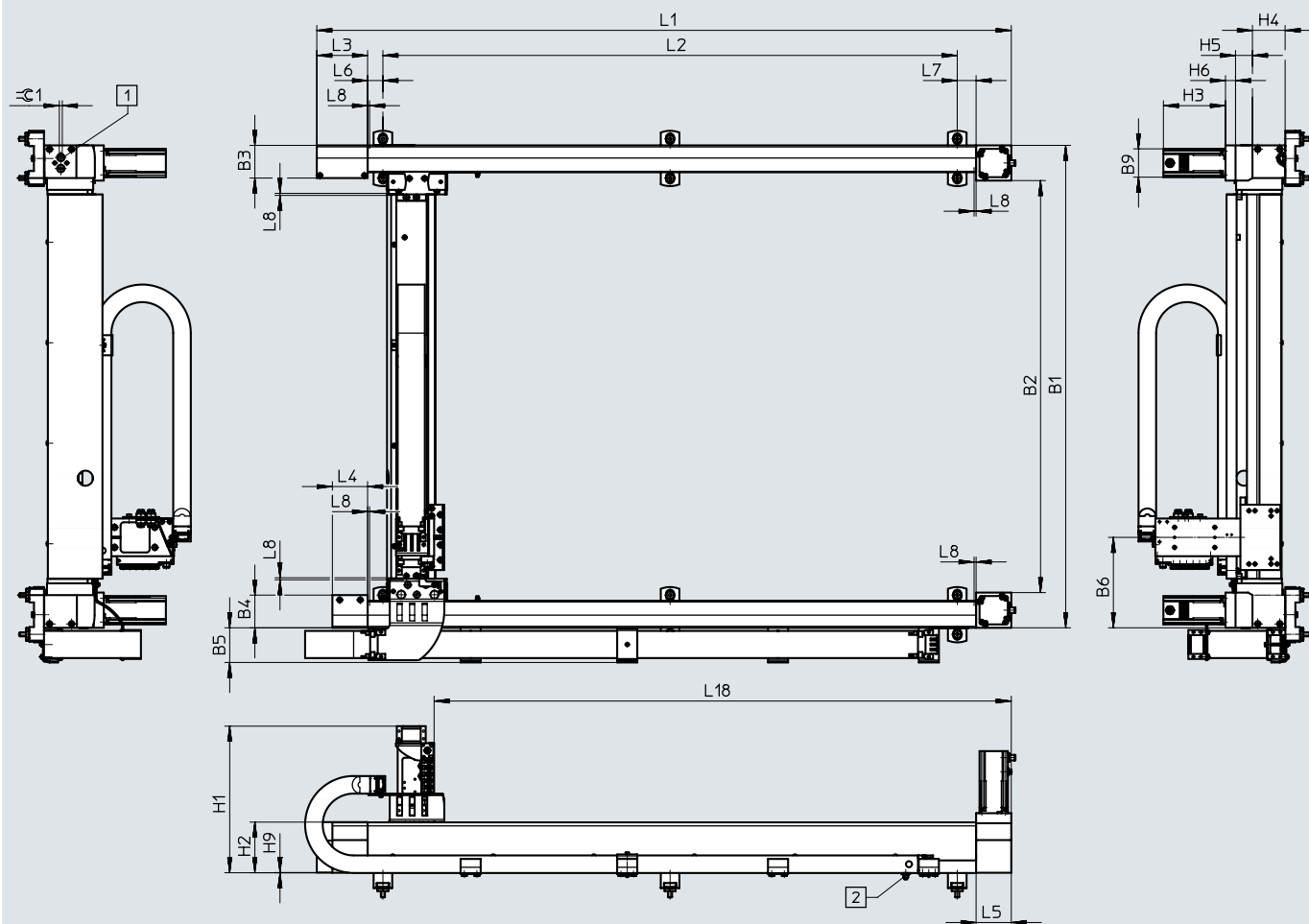

- [1] Screw for toothed belt tension
- [2] Earthing point
- L8 Safety distance per side

EXCM-40-...-B – Motor attachment position underneath

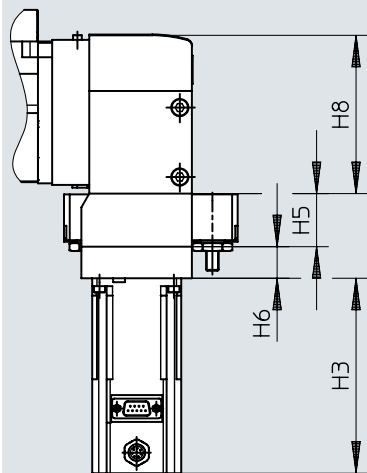

EXCM-40-... – Motor interface

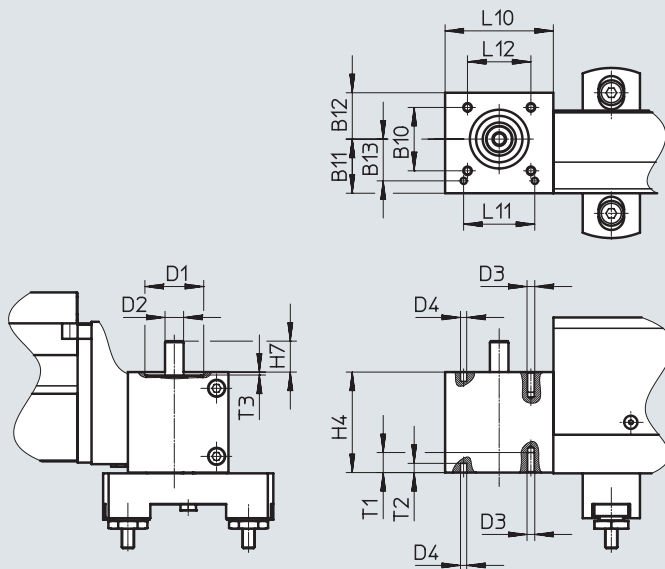

Datasheet

Dimensions

Download CAD data → www.festo.com

EXCM-40-... – Slide

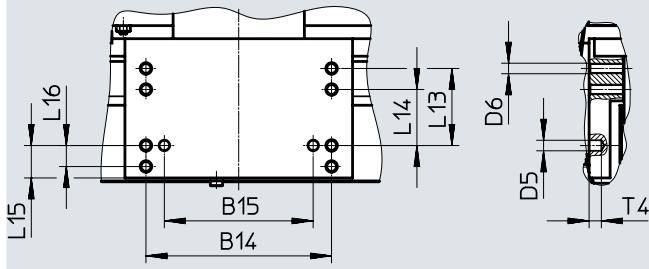

Type	B3	B4	B5	B6	B9	B10	B11	B12	B13	B14
EXCM-40	65	65	69	179.9	56.4	41	35	30	±0.05	±0.1

Type	B15	D1	D2	D3	D4	D5	D6	H1	H2	H3
EXCM-40	±0.03	∅ H7	∅ h6	M5	∅ H7	∅ H7	M6	Approx. 293	100.8	12.4/159.5 ¹⁾

Type	H4	H5	H6	H7	H8	H9	L3	L4	L5	L6	L7	L8
EXCM-40	65	33.6	20	20	100.3	0.5	101	70	70	30.5	37.5	6

Type	L10	L11	L12	L13	L14	L15	L16	T1	T2	T3	T4	⌀G1
EXCM-40	70	±0.03	41	±0.1	±0.1	18.5	±0.1	12	6	1.9	7	6

Stroke-dependent dimensions

Stroke of the X-axis	L1	L2	L18	Stroke of the Y-axis	B1	B2
200 ... 2000	382+stroke	→ Page 30	167.2+stroke	200 ... 1000	360+stroke	230+stroke

1) With brake

Note

Depending on the stroke of the X-axis, a different number of profile mountings is required. The distance between the profile mountings must always be the same (→ page 30).

The tension of the toothed belt must be set before commissioning. The tools required to do this (e.g. frequency meter) are not included in the scope of delivery.

Ordering data – Modular product system

Ordering table		Conditions	Code	Enter code
Size	40			
Module no.	3741955			
Product type	EXCM series M		EXCM	EXCM
Size	40		-40	-40
Stroke of the X-axis [mm]	200 ... 2000			
Stroke of the Y-axis [mm]	200 ... 1000			
Guide	Recirculating ball bearing guide		-KF	-KF
Motor type	Stepper motor with brake		-SB	
	Stepper motor		-ST	
	Without motor		-W	
Motor attachment position	Underneath		-B	
	On top		-T	
Controller	None			
Cable length	None			
	5 m		6	
	10 m		7	
Attachment components	None			
Mounting kit	With mounting kit			
	With adjusting kit		-J	
Document language	German		-DE	
	English		-EN	
	Spanish		-ES	
	French		-FR	
	Italian		-IT	
	Russian		-RU	
	Swedish		-SV	
Chinese		-ZH		

 - **Note**

In combination with key feature W (without motor), the planar surface gantry EXCM is provided without a coupling housing and without a coupling.

 - **Note**

The planar surface gantry can only be operated with a load voltage of 48 V.

Accessories

 **Note**

Depending on the combination of motor and drive, it may not be possible to reach the maximum feed force of the drive.

Third-party motors that have an overly high driving torque may damage the linear gantry. When selecting the motors, please observe the limits specified in the technical data.

Permissible axis/motor combinations with axial kit

Datasheets → Internet: eamm-a

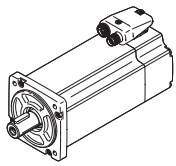
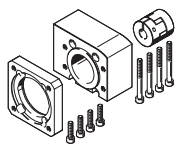
Motor/gear unit ¹⁾	Axial kit	
	 <ul style="list-style-type: none"> • Kits for third-party motors → Internet: eamm-a 	
Type	Part no.	Type
EXCM-40		
With stepper motor		
EMMS-ST-57-...	8165289	EAMM-A-X48-57A

1) The input torque must not exceed the max. permissible transferable torque of the axial kit.

Ordering data

Coupling	For axial kit	Part no.	Type
	EAMM-A-X48-57A	550995	EAMC-30-35-6.35-12

Accessories

Profile mounting MUE

For size 30

Material:

Anodised aluminium

RoHS-compliant

For mounting the planar surface gantry
(scope of delivery: 1 pair)

Included in the scope of delivery of the
planar surface gantry:

X-stroke < 500 mm: 2 pairs

X-stroke ≥ 500 mm: 3 pairs

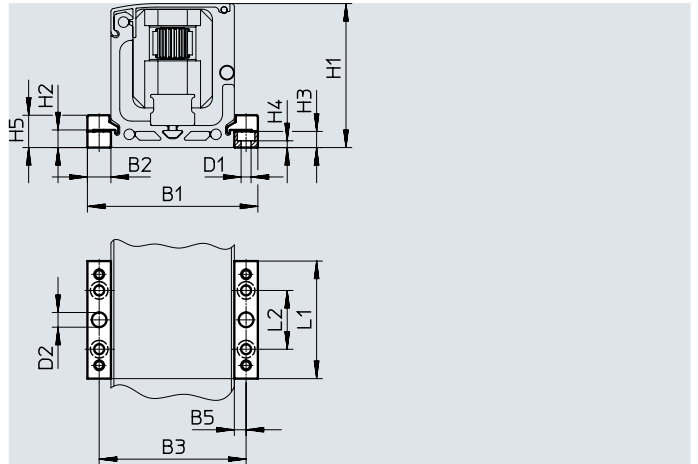

Dimensions and ordering data

For size	B1	B2	B3	B5	D1 ∅	D2 ∅ H7	H1	H2	H3
30	58	8	50	4	3.4	5	49	6	5.5

For size	H4	H5	L1	L2	Weight [g]	Part no.	Type
30	2.3	11	40	20	20	558042	MUE-50

Adjusting kit EADC-E11

For size 30

Material:

Anodised aluminium

RoHS-compliant

For mounting and aligning the planar
surface gantry. The kit is height adjust-
able.

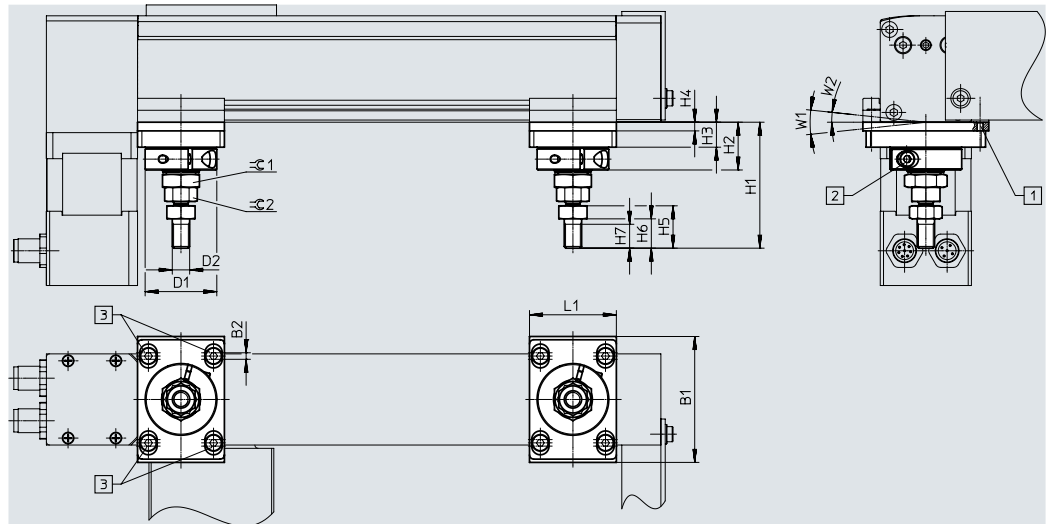
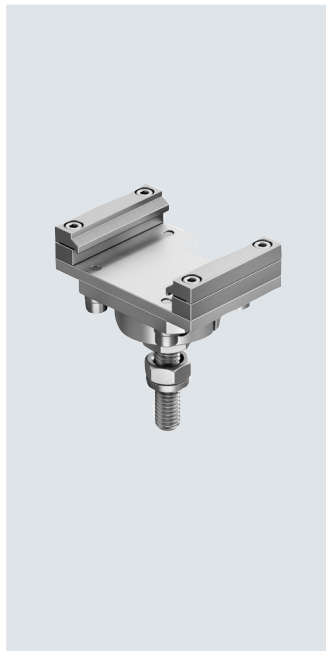

- [1] Interface for MUE-50
- [2] Socket head screw M4x16
- [3] Socket head screw M4x8

Dimensions and ordering data

For size	B1	B2	D1 ∅	D2	H1 +12/-2	H2	H3	H4	H5	H6	H7
30	58	3	33	M8	58	22	11.5	4	19.5	13.5	11

For size	L1	W1	W2	≈G1	≈G2	Weight [g]	Part no.	Type
30	40	12°	6°	17	13	160	4706964	EADC-E11-30

Accessories

Mounting kit EAHT-E9

For size 30

Material:
Anodized aluminium
RoHS-compliant

Prepared hole patterns for:

- Mini slide EGSL-35
- Mini slide DGSL-8/-10/-12
- Electric slide EGSK-20/-26

- Electric cylinder EPCO-16
- Mini slide EGSC-BS-25/-32

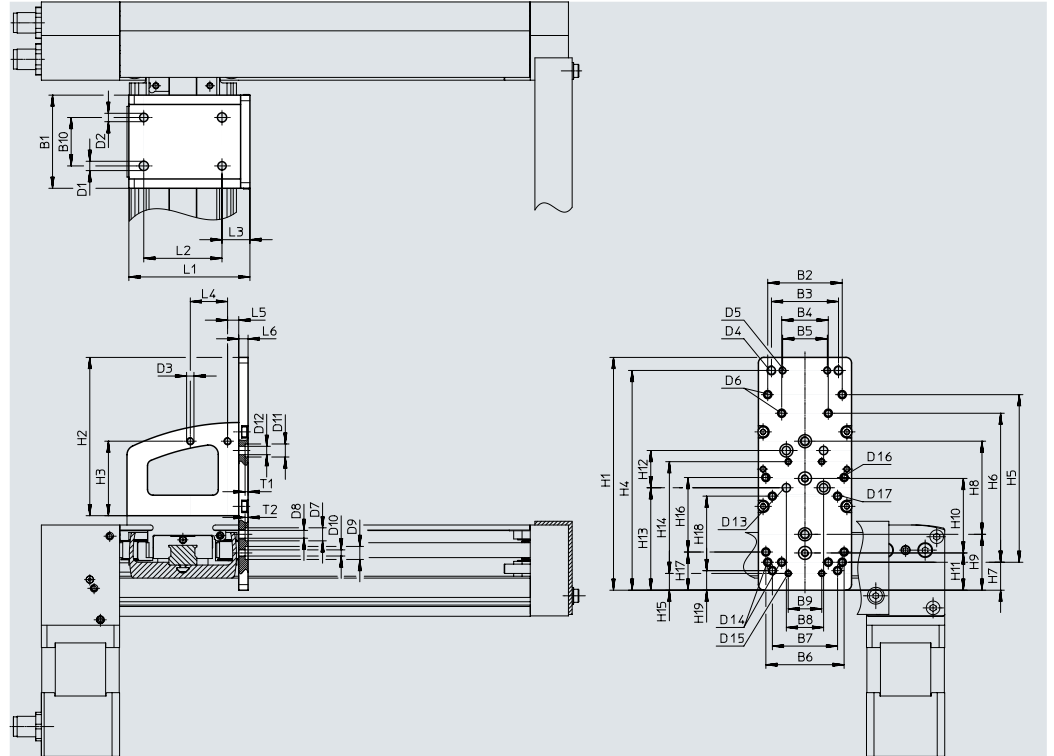
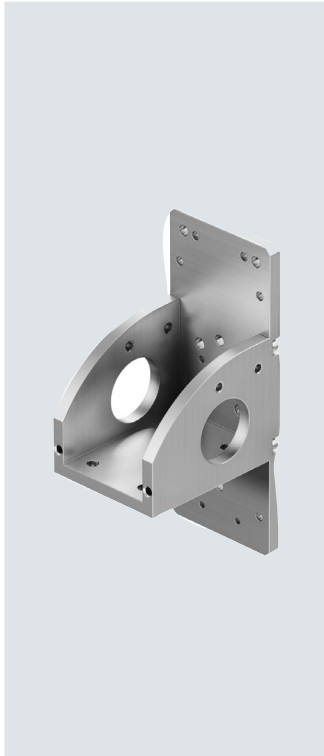

Dimensions and ordering data

For size	B1	B2	B3	B4	B5	B6	B7	B8	B9	B10	D1	D2
											∅ H7	∅
30	50	40	36	25	24	42	35	20	18	26	5	4.5
For size	D3	D4	D5	D6	D7	D8	D9	D10	D11	D12	D13	D14
					∅ H7		∅ H7			∅	∅	
30	M4	M5	M4	M4	7	M5	7	M4	7	4.5	4.5	M4
For size	D15	D16	D17	H1	H2	H3	H4	H5	H6	H7	H8	H9
							±0.2					
30	M3	M4	M4	125	85	40	118	90	80	15	50	30
For size	H10	H11	H12	H13	H14	H15	H16	H17	H18	H19	L1	L2
30	40	20	20	55	60	9	40	20.5	40	10.5	65	42
For size	L3	L4	L5	L6	T1	T2	Weight [g]	Part no.	Type			
					±0.1	±0.1						
30	15	20	6	5	1.6	1.6	165	4070088	EAHT-E9-FB-3D-30			

Accessories

Sensor mounting EAPR

For size 30
(incl. switch lug)

Material:
Retaining bracket: Wrought aluminium alloy
Switch lug: Steel
RoHS-compliant

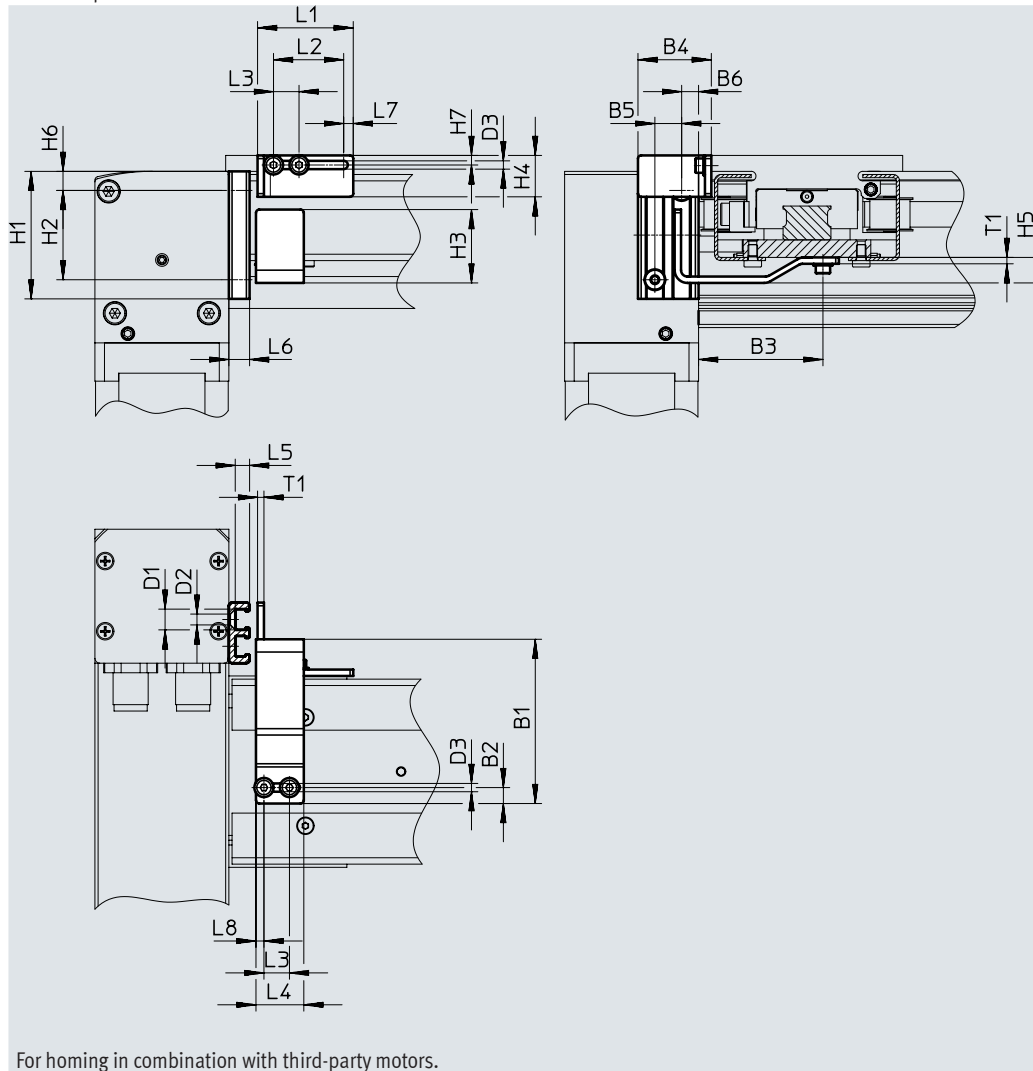
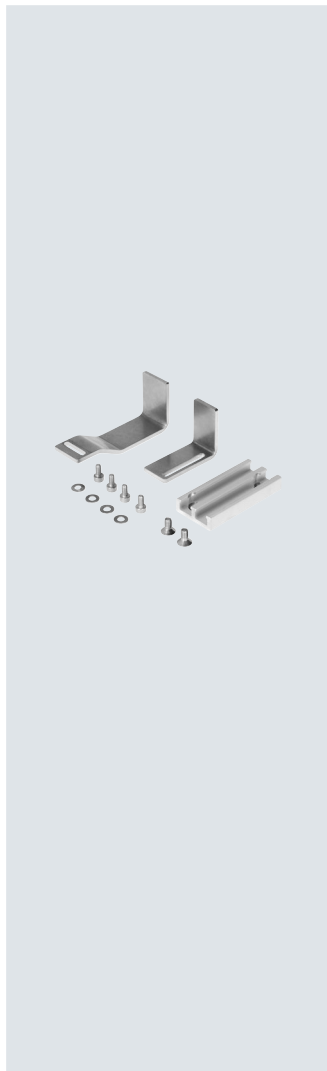

Dimensions and ordering data										
For size	B1	B2	B3	B4	B5	B6	D1 ∅	D2 ∅	D3 ∅	H1
30	51.5	5	39	23	8.4	5.3	6.5	3.4	2.6	40
For size	H2	H3	H4	H5	H6	H7	L1	L2	L3	L4
30	28	23	13	8	6	3	30	22	8	15
For size	L5	L6	L7	L8	T1	Weight [g]	Part no.	Type		
30	4.5	6.5	3	2.5	2	330	2319236	EAPR-E11-30		

Accessories

Energy chain and connection set for size 30

Ordering data – Energy chain

EADH-U-30-30

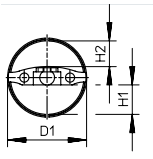

EADH-U-30-40

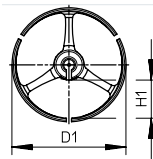

Type		D1	H1	H2
	EADH-U-3D-30	34.5	12.5	11
	EADH-U-3D-40	45	15	–

For size	Max. bending radius [mm]	Length [mm]	Weight [g]	Part no.	Type
30	50	Approx. 500	75	8059999	EADH-U-3D-30
	58	Approx. 500	100	8060324	EADH-U-3D-40

Ordering data – Connection set

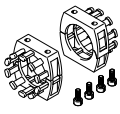
	For energy chain	Description	Part no.	Type
	EADH-U-3D-30	For mounting the energy chain.	8060325	EAHT-AE-3D-30
	EADH-U-3D-40	Included in the scope of delivery: • 2 connecting pieces • 4 socket head screws M4x10	8060326	EAHT-AE-3D-40

Accessories

Adjusting kit EADC-E12

For size 40

Material:
Anodised aluminium
RoHS-compliant

For mounting and aligning the planar surface gantry. The kit is height adjustable.

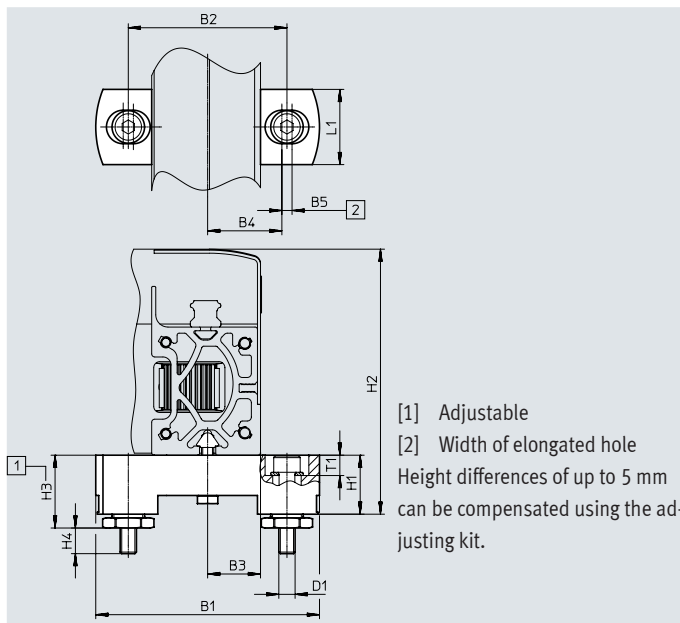
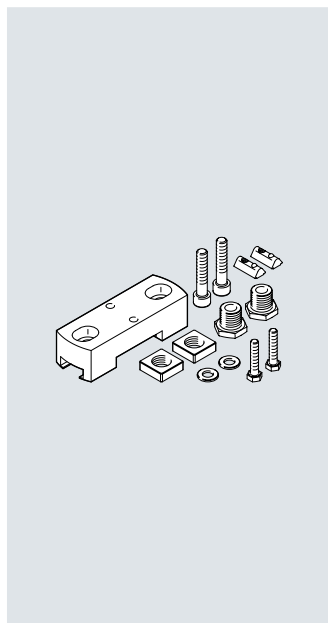

Dimensions and ordering data

For size	B1	B2	B3	B4 ±0.2	B5	D1	H1	H2
40	110	78	26	36.5	5	M8	29	129.8

For size	H3 min.	H3 max.	H4 max.	L1	T1 ±0.1	Weight [g]	Part no.	Type
40	34.8	39.8	14	37	10	800	8029165	EADC-E12-40

Mounting kit EAHM-E12

For size 40

Material:
Anodised aluminium
RoHS-compliant

For mounting the planar surface gantry. The kit is not height adjustable.

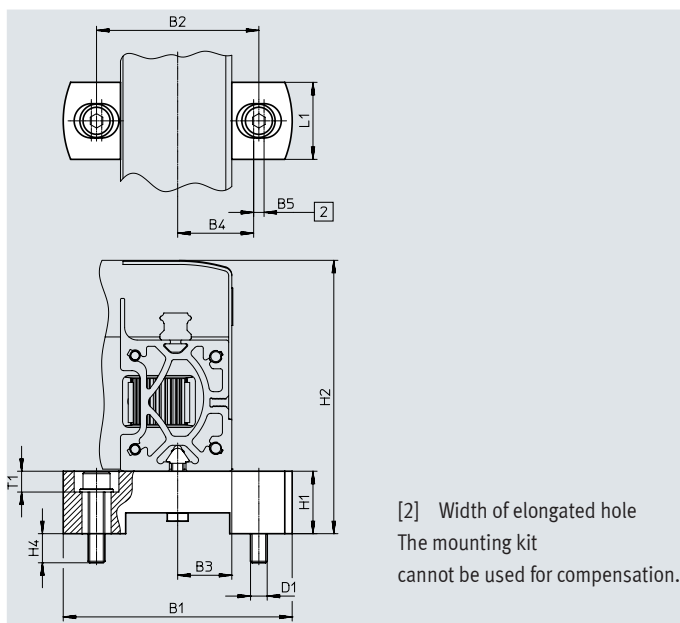
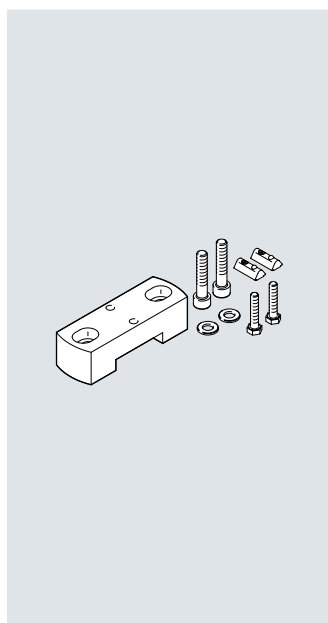

Dimensions and ordering data

For size	B1	B2	B3	B4 ±0.2	B5	D1	H1 ±0.2
40	110	78	26	36.5	5	M8	30

For size	H2	H4 max.	L1	T1 ±0.1	Weight [g]	Part no.	Type
40	131.3	14	37	10	330	3489340	EAHM-E12-K-40

Accessories

Sensor mounting EAPR

For size 40

Material:

Switch lug: Steel

Sensor bracket: Wrought aluminium alloy

RoHS-compliant

For proximity switches

SIES-V3B and SIES-Q8B

(for sensing the position of the slide on the X-axis)

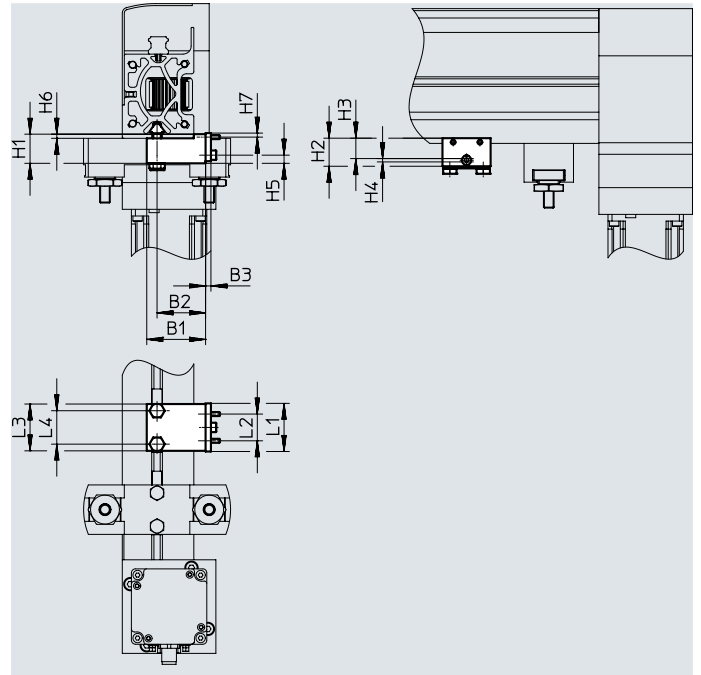
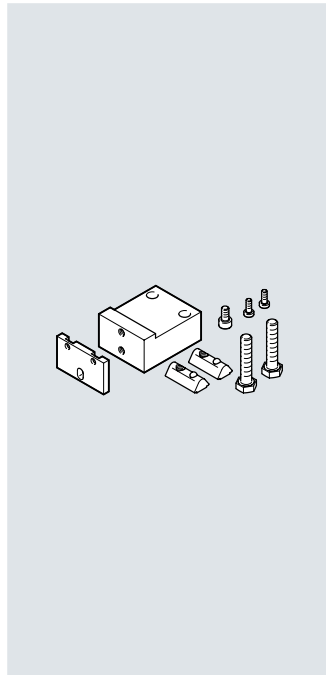

Dimensions and ordering data											
For size	B1	B2	B3	H1	H2	H3	H4	H5	H6	H7	
40	44	36.3	4	21.8	21	±0.1	2.5	6.1	3.1	3	

For size	L1	L2	L3	L4	Weight [g]	Part no.	Type
40	36	20	35	25	120	2536353	EAPR-E12-40

Accessories

Proximity switches for size 30

Ordering data – Proximity switches for T-slot, inductive

Datasheets → Internet: sies

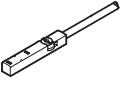
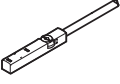
Type of mounting	Electrical connection	Switching output	Cable length [m]	Part no.	Type
N/O					
 Inserted in the slot from above, flush with the cylinder profile	Cable, 3-core	PNP	7.5	551386	SIES-8M-PS-24V-K-7.5-OE
	Plug M8x1, 3-pin		0.3	551387	SIES-8M-PS-24V-K-0.3-M8D
	Cable, 3-core	NPN	7.5	551396	SIES-8M-NS-24V-K-7.5-OE
	Plug M8x1, 3-pin		0.3	551397	SIES-8M-NS-24V-K-0.3-M8D
N/C					
 Inserted in the slot from above, flush with the cylinder profile	Cable, 3-core	PNP	7.5	551391	SIES-8M-PO-24V-K-7.5-OE
	Plug M8x1, 3-pin		0.3	551392	SIES-8M-PO-24V-K-0.3-M8D
	Cable, 3-core	NPN	7.5	551401	SIES-8M-NO-24V-K-7.5-OE
	Plug M8x1, 3-pin		0.3	551402	SIES-8M-NO-24V-K-0.3-M8D



 **Note**

For homing in combination with third-party motors.

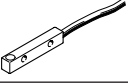
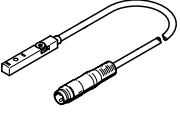
Proximity switches for size 40

Designation	Description	Cable length [m]	Part no.	Type
Proximity switches for sensing the position of the slide on the X-axis				
- To be used in combination with sensor mounting EAPR-E12				
	• For EXCM-40	PNP, N/O contact	–	150491 SIES-V3B-PS-S-L
	• For EXCM-40	PNP, N/C contact	–	174552 SIES-Q8B-PO-K-L
Proximity switch (inductive) for sensing the position of the slide on the Y-axis				
	Cable with plug			
	<ul style="list-style-type: none"> • For EXCM-40 • For DC voltage 	PNP, N/C contact	0.3	551392 SIES-8M-PO-24V-K-0.3-M8D
		PNP, N/O contact	0.3	551387 SIES-8M-PS-24V-K-0.3-M8D

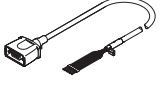
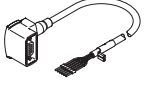
Accessories

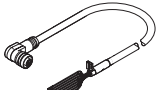
Designation	Description	Cable length [m]	Part no.	Type
For stepper motor EMMS-ST				
Motor cable¹⁾				
	<ul style="list-style-type: none"> For stepper motor EMMS-ST-42/57 with CMMT-ST Straight plug 	2.5	1450369	NEBM-S1G9-E-2.5-Q5-LE6
		5	1450370	NEBM-S1G9-E-5-Q5-LE6
		7	1450371	NEBM-S1G9-E-7-Q5-LE6
		10	1450372	NEBM-S1G9-E-10-Q5-LE6
		15	5085055	NEBM-S1G9-E-15-Q5-LE6
		20	5085056	NEBM-S1G9-E-20-Q5-LE6
	<ul style="list-style-type: none"> For stepper motor EMMS-ST-42/57 with CMMT-ST Angled plug 	2.5	1450737	NEBM-S1W9-E-2.5-Q5-LE6
		5	1450738	NEBM-S1W9-E-5-Q5-LE6
		7	1450739	NEBM-S1W9-E-7-Q5-LE6
		10	1450740	NEBM-S1W9-E-10-Q5-LE6
		15	610856	NEBM-S1W9-E-15-Q5-LE6
		Encoder cable¹⁾		
	<ul style="list-style-type: none"> For stepper motor EMMS-ST-42/57 with CMMT-ST Straight plug 	2.5	1451587	NEBM-M12G8-E-2.5-LE8
		5	1451588	NEBM-M12G8-E-5-LE8
		7	1451589	NEBM-M12G8-E-7-LE8
		10	1451590	NEBM-M12G8-E-10-LE8
		15	611110	NEBM-M12G8-E-15-LE8
		20	611111	NEBM-M12G8-E-20-LE8
	<ul style="list-style-type: none"> For stepper motor EMMS-ST-42/57 with CMMT-ST Angled plug 	2.5	1451675	NEBM-M12W8-E-2.5-LE8
		5	1451676	NEBM-M12W8-E-5-LE8
		7	1451677	NEBM-M12W8-E-7-LE8
		10	1451678	NEBM-M12W8-E-10-LE8
		15	610858	NEBM-M12W8-E-15-LE8

1) Cables especially suitable for the motor controller and motor.
Degree of protection to IP65 (in assembled state)