

## Axial kits EAMM-A

**FESTO**

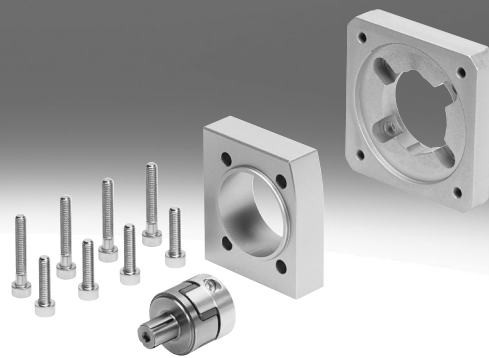

Festo Core Range  
Solves the majority of your automation tasks

Worldwide:  
Expected high  
Easy selection

Quickest delivery – wherever, whenever  
Festo quality  
Easy and fast to select

With the Festo Core Range, we have selected the most important products and functions from our broad product catalogue.

The Core Range offers you the best value for your automation needs.

Just look  
for the  
star!

## Key features

### At a glance

The following kits are used for coupling the motors and axes using friction-locking. The couplings transmit the drive energy of the motor to the axes.

They can be connected to Festo motors or third-party motors.

The selection provides you with an overview of possible combinations. The planning tool "Electric Motion Sizing" helps you to find the right combination.

### Electric Motion Sizing

Configuring electromechanical drives



Create the optimum drive package quickly and reliably. Electric Motion Sizing calculates suitable combinations of electric axis, electric motor and servo drive using just a few application details. It provides you with all the relevant data including the bill of materials and documentation for the selected combination. This avoids design errors and results in significantly improved energy efficiency for the system.

A smooth connection to the Festo Automation Suite also makes commissioning easier for you.

To find out more, go to [www.festo.com/ems](http://www.festo.com/ems)

### Quickly find the right axis/motor combination with third-party motors

Select the required axis and note the code in the "Motor interface" column

Look for the interface code in the table of interfaces for third-party motors (→ from page 64) and check if the required third-party motor is listed

#### Zulässige Achs-/Motor-Kombinationen mit Elektrozyliner ESBF

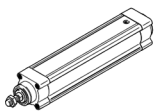

Schnittstellentabelle für Fremdmotoren  
→ ab Seite 67  
Technische Daten für Axialbausätze  
→ ab Seite 72

| Motor/Getriebe <sup>1)</sup> | Schnittstelle | Axialbausatz |                                 |
|------------------------------|---------------|--------------|---------------------------------|
| Typ                          | Motor         | Teile-Nr.    | Typ                             |
| <b>ESBF-32</b>               |               |              |                                 |
| mit Servomotor               |               |              |                                 |
| EMME-AS-40-...               | 40P           | 1976465      | EAMM-A-D32-40P                  |
|                              |               | 2207372      | EAMM-A-D32-40P-S1 <sup>2)</sup> |
| EMMS-AS-40-..., Fremdmotor   |               |              |                                 |
|                              | 40A           | 543147       | EAMM-A-D32-40A                  |
|                              |               | 1322178      | EAMM-A-D32-40A-S1 <sup>2)</sup> |

| Fremdmotoren und Fremdgetriebe |  |   |
|--------------------------------|--|---|
| Schnittstelle                  | Hersteller   | Typ   |
| <b>Motor</b>                   |  |   |
| <b>Fremdmotoren</b>            |  |   |
| 50AA                           | SEW Eurodrive  | CMP40; CMP40S/IM  |
|                                | Bosch Rexroth  | MKD 025; MSK030B; MSK030C; MSK03x   |
|                                | Danaher Motion   | AKM21 AC; AKM21 AN; AKM22 AC; AKM22 AN; AKM23 AC; AKM23 AN; AKM24 AC; AKM24 AN; AKM2x-AC/AN |
|                                | Beckhoff   | AM3021; AM3022; AM3023; AM3024  |
|                                | B+R Automation   | 8ISA2   |
| Mitsubishi                     | AKM21; AKM21x-Ax; AKM22; AKM22x-Ax; AKM23; AKM23x-Ax; AKM24; AKM24x-Ax |   |
| 60AA                           | Fastech  | EzM2-60S/M/L  |

## Overview of interfaces

| Axis mechanism interface |  |
|--------------------------|--|
| D19                      | EGSL-35  |
| D32                      | ESBF-32, EGSL-45, ERMB-20, EHMB-20                         |
| D32-35A                  | ERMB-20, EHMB-20   |
| D40                      | ESBF-40, EGSL-55, ERMB-25, EHMB-25                         |
| D50                      | ESBF-50  |
| D60                      | ESBF-63, EGSL-75, ERMB-32, EHMB-32                         |
| D80                      | ESBF-80  |
| D100                     | ESBF-100   |
| L27                      | EGC-50-...-TB  |
| L38                      | EGC-70-...-TB, ELGD-TB-100                                 |
| L48                      | EGC-80-...-TB, ELGD-TB-80                                  |
| L62                      | EGC-120-...-TB   |
| L95                      | EGC-185-...-TB   |
| M43                      | EGC-HD-125-...-TB  |
| M48                      | EGC-HD-160-...-TB  |
| M80                      | EGC-HD-220-...-TB  |
| N38                      | ELGA-TB-...-70   |
| N48                      | ELGA-TB-...-80, ELCC-TB-...-60, ELCC-TB-...-70, ELGD-TB-60 |
| N80                      | ELGA-TB-...-120, ELCC-TB-...-90                            |
| L95                      | ELGA-TB-...-150, ELCC-TB-...-110                           |
| P3-28D                   | EGSK-15  |
| P4-28B                   | EGSK-20  |
| P5-28B                   | EGSK-26  |
| P6-38A                   | EGSK-33  |
| P8-38A                   | EGSK-46  |
| R27                      | ELGG-...-35, ELGR-...-35                                   |
| R38                      | ELGG-...-45, ELGR-...-45                                   |
| R48                      | ELGG-...-55, ELGR-...-55                                   |
| S38                      | EGC-70-...-BS, EGC-HD-125-...-BS, ELGA-BS-...-70           |
| S48                      | EGC-80-...-BS, EGC-HD-160-...-BS, ELGA-BS-...-80           |
| S62                      | EGC-120-...-BS, EGC-HD-220-...-BS, ELGA-BS-...-120         |
| S95                      | EGC-185-...-BS, ELGA-BS-...-150                            |
| V20                      | EPCC-25, EGSC-25   |
| V25                      | EPCC-32, EGSC-32, ELGC-BS-32                               |
| V32                      | EPCC-45, EGSC-45, ELGC-BS-45, ELGC-TB-45                   |
| T42                      | EPCC-60, EGSC-60, ELGC-BS-60, ELGC-TB-60, ELGD-BS-60/100   |
| T46                      | ELGC-BS-80, ELGC-TB-80, ELGT-BS-90/-120/-160, ELGD-BS-80   |
| X22                      | EXCM-30  |
| X48                      | EXCM-40, EXCH-40   |
| X62                      | EXCH-60  |
| Y62                      | EXCT-30  |

| Motor interface |                          |
|-----------------|--------------------------|
| 28A             | Stepper motor EMMS-ST-28 |
| 28AA            | Third-party motor        |

|      |   |
|------|---|
| 38AA | Third-party motor                                       |
| 40A  | Third-party motor                                       |
| 40G  | Gear unit EMGA-40, third-party gear unit                |
| 40P  | Servo motor EMME-AS-40, EMMB-AS-40, third-party motor   |
| 40R  | Third-party motor                                       |
| 40RA | Third-party motor                                       |
| 42A  | Stepper motor EMMT-ST-42, EMMB-ST-42, third-party motor |
| 42AB | Third-party motor                                       |
| 50GA | Third-party motor                                       |
| 55A  | Third-party motor                                       |
| 57A  | Stepper motor EMMT-ST-57, EMMB-ST-57                    |
| 57AA | Third-party motor                                       |
| 58AA | Third-party motor                                       |
| 60AA | Third-party motor                                       |
| 60AB | Third-party motor                                       |
| 60G  | Gear unit EMGA-60-P-...-SAS/SST                         |
| 60H  | Gear unit EMGA-60-...-EAS, third-party motor            |
| 60P  | Servo motor EMMT-AS-60, EMMB-AS-60, third-party motor   |
| 60PA | Third-party motor                                       |
| 60R  | Third-party motor                                       |
| 60RA | Third-party motor                                       |
| 70A  | Third-party motor                                       |
| 70AA | Third-party motor                                       |
| 70GA | Third-party gear unit                                   |
| 80G  | Gear unit EMGA-80, third-party gear unit                |
| 80P  | Servo motor EMMT-AS-80, EMMB-AS-80, third-party motor   |
| 80PA | Third-party motor                                       |
| 80PB | Third-party motor                                       |
| 82AA | Third-party motor                                       |
| 84AA | Third-party motor                                       |
| 85AA | Third-party motor                                       |
| 87A  | Stepper motor EMMT-ST-87, EMMB-ST-87                    |
| 90GA | Third-party motor                                       |
| 100A | Servo motor EMMT-AS-100, third-party motor              |
| 120G | Gear unit EMGA-120-...-SAS, third-party gear unit       |
| 150A | Servo motor EMMT-AS-150                                 |
| 160G | Gear unit EMGA-160-...-SAS, third-party gear unit       |
| 190A | Servo motor EMMT-AS-190                                 |

## Product range overview

### Permissible axis/motor combinations with electric cylinder EPCC

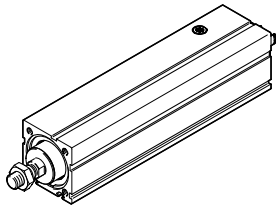

Table of interfaces for third-party motors

→ from page 64

Technical data for axial kits

→ from page 69

| Motor <sup>1)</sup><br>Type                   | Motor interface | Axial kit |                 |
|---|-----------------|-----------|-----------------|
|   |                 | Part no.  | Type            |
| <b>EPCC-25</b>                                |                 |           |                 |
| <b>With stepper motor</b>                     |                 |           |                 |
| EMMS-ST-28-...                                | 28A             | ★ 4505258 | EAMM-A-V20-28A  |
| Third-party motor                             | 28AA            | 8093016   | EAMM-A-V20-28AA |
| <b>EPCC-32</b>                                |                 |           |                 |
| <b>With servo motor</b>                       |                 |           |                 |
| Third-party motor                             | 38AA            | 8093162   | EAMM-A-V25-38AA |
| EMME-AS-40-..., EMMB-AS-40-...                | 40P             | ★ 4491059 | EAMM-A-V25-40P  |
| Third-party motor                             | 40R             | 8087062   | EAMM-A-V25-40R  |
| Third-party motor                             | 40RA            | 8094100   | EAMM-A-V25-40RA |
| <b>With stepper motor</b>                     |                 |           |                 |
| Third-party motor                             | 35A, 35AB       | 8093255   | EAMM-A-V25-35A  |
| EMMT-ST-42, EMMB-ST-42-..., third-party motor | 42A             | ★ 4582608 | EAMM-A-V25-42A  |
| Third-party motor                             | 42AB            | 8094108   | EAMM-A-V25-42AB |
| <b>EPCC-45</b>                                |                 |           |                 |
| <b>With servo motor</b>                       |                 |           |                 |
| Third-party motor                             | 38AA            | 8093023   | EAMM-A-V32-38AA |
| EMME-AS-40-..., EMMB-AS-40-...                | 40P             | ★ 4595742 | EAMM-A-V32-40P  |
| Third-party motor                             | 40R             | 8087090   | EAMM-A-V32-40R  |
| Third-party motor                             | 40RA            | 8094180   | EAMM-A-V32-40RA |
| Third-party motor                             | 58AA            | 8098982   | EAMM-A-V32-58AA |
| EMMT-AS-60-..., EMMB-AS-60-...                | 60P             | ★ 4608750 | EAMM-A-V32-60P  |
| Third-party motor                             | 60PA            | 8091053   | EAMM-A-V32-60PA |
| Third-party motor                             | 60RA            | 8093041   | EAMM-A-V32-60RA |
| <b>With stepper motor</b>                     |                 |           |                 |
| EMMT-ST-42, EMMB-ST-42-..., third-party motor | 42A             | ★ 4281142 | EAMM-A-V32-42A  |
| Third-party motor                             | 42AB            | 8094200   | EAMM-A-V32-42AB |
| EMMT-ST-57, EMMB-ST-57-...                    | 57A             | ★ 4597016 | EAMM-A-V32-57A  |
| Third-party motor                             | 60AA            | 8092271   | EAMM-A-V32-60AA |
| <b>EPCC-60</b>                                |                 |           |                 |
| <b>With servo motor</b>                       |                 |           |                 |
| Third-party motor                             | 55A             | 8082614   | EAMM-A-T42-55A  |
| Third-party motor                             | 58AA            | 8094935   | EAMM-A-T42-58AA |
| EMMT-AS-60-..., EMMB-AS-60-...                | 60P, 60PA       | ★ 4133487 | EAMM-A-T42-60P  |
| Third-party motor                             | 60R             | 8093289   | EAMM-A-T42-60R  |
| Third-party motor                             | 60RA            | 8092264   | EAMM-A-T42-60RA |
| EMMT-AS-80-..., EMMB-AS-80-...                | 80P             | ★ 4623788 | EAMM-A-T42-80P  |
| <b>With stepper motor</b>                     |                 |           |                 |
| EMMT-ST-57, EMMB-ST-57-...                    | 57A             | ★ 4327034 | EAMM-A-T42-57A  |
| Third-party motor                             | 60AA            | 8092255   | EAMM-A-T42-60AA |
| Third-party motor                             | 60AB            | 8094949   | EAMM-A-T42-60AB |
| EMMT-ST-87, EMMB-ST-87-...                    | 87A             | ★ 4610008 | EAMM-A-T42-87A  |

1) The input torque must not exceed the max. permissible transferable torque of the axial kit.

## Product range overview

## Permissible axis/motor combinations with electric cylinder ESBF

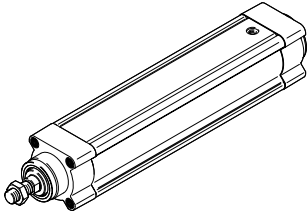

Table of interfaces for third-party motors

→ from page 64

Technical data for axial kits

→ from page 69

| Motor/gear unit <sup>1)</sup>                        | Motor interface | Axial kit            |   |
|--|-----------------|----------------------|---|
|  |                 | Part no.             | Type  |
| <b>ESBF-32</b>                                       |                 |                      |   |
| <b>With servo motor</b>                              |                 |                      |   |
| EMME-AS-40-..., EMMB-AS-40-...                       | 40P             | ★ 1976465<br>2207372 | EAMM-A-D32-40P<br>EAMM-A-D32-40P-S1 <sup>2)</sup> |
| Third-party motor                                    | 40A             | 543147               | EAMM-A-D32-40A                                    |
|  |                 | 1322178              | EAMM-A-D32-40A-S1 <sup>2)</sup>                   |
| Third-party motor                                    | 40R             | 8105826              | EAMM-A-D32-40R                                    |
| Third-party motor                                    | 40RA            | 8125610              | EAMM-A-D32-40RA                                   |
| Third-party motor                                    | 55A             | 550979               | EAMM-A-D32-55A                                    |
|  |                 | 1322180              | EAMM-A-D32-55A-S1 <sup>2)</sup>                   |
| Third-party motor                                    | 58AA            | 8105884              | EAMM-A-D32-58AA                                   |
| EMMT-AS-60-..., EMMB-AS-60-..., third-party motor    | 60P             | 8197499              | EAMM-A-D32-60P-G2                                 |
|  |                 | 8197495              | EAMM-A-D32-60P-S1-G2 <sup>2)</sup>                |
| Third-party motor                                    | 60R             | 8105918              | EAMM-A-D32-60R                                    |
| Third-party motor                                    | 60RA            | 8105889              | EAMM-A-D32-60RA                                   |
| <b>With servo motor and gear unit</b>                |                 |                      |   |
| EMME-AS-40-...<br>EMGA-40-P-G...-EAS-40              | 40G             | 1454238              | EAMM-A-D32-40G                                    |
|  |                 | 2256396              | EAMM-A-D32-40G-S1 <sup>2)</sup>                   |
| EMMT-AS-60-...<br>EMGA-60-P-G...-EAS-60              | 60H             | 2946760              | EAMM-A-D32-60H                                    |
|  |                 | 2946761              | EAMM-A-D32-60H-S1 <sup>2)</sup>                   |
| <b>With servo motor and right-angle gear unit</b>    |                 |                      |   |
| EMME-AS-40-..., EMMB-AS-40-...<br>EMGA-40-A-G...-40P | 40G             | 1454238              | EAMM-A-D32-40G                                    |
|  |                 | 2256396              | EAMM-A-D32-40G-S1 <sup>2)</sup>                   |
| EMMT-AS-60-..., EMMB-AS-60-...<br>EMGA-60-A-G...-60P | 60H             | 2946760              | EAMM-A-D32-60H                                    |
|  |                 | 2946761              | EAMM-A-D32-60H-S1 <sup>2)</sup>                   |
| <b>With stepper motor</b>                            |                 |                      |   |
| Third-party motor                                    | 60AA            | 8105887              | EAMM-A-D32-60AA                                   |

1) The input torque must not exceed the max. permissible transferable torque of the axial kit.

2) Increased degree of protection IP65

## Product range overview

### Permissible axis/motor combinations with electric cylinder ESBF

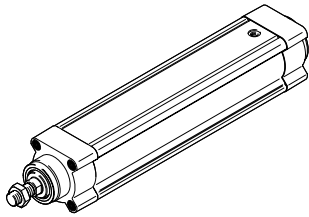

Table of interfaces for third-party motors

→ from page 64

Technical data for axial kits

→ from page 69

| Motor/gear unit <sup>1)</sup><br>Type               | Motor interface | Axial kit           |   |
|---|-----------------|---------------------|---|
|   |                 | Part no.            | Type  |
| <b>ESBF-32</b>                                      |                 |                     |   |
| <b>With stepper motor</b>                           |                 |                     |   |
| EMMT-ST-42, EMMB-ST-42-..., third-party motor       | 42A             | ★ 543148<br>1322179 | EAMM-A-D32-42A<br>EAMM-A-D32-42A-S1 <sup>2)</sup> |
| EMMT-ST-57, EMMB-ST-57-..., third-party motor       | 57A             | ★ 550980<br>1322181 | EAMM-A-D32-57A<br>EAMM-A-D32-57A-S1 <sup>2)</sup> |
| Third-party motor                                   | 60AA            | 8105887             | EAMM-A-D32-60AA                                   |
| <b>With stepper motor and gear unit</b>             |                 |                     |   |
| EMMT-ST-42, EMMB-ST-42-...<br>EMGA-40-P-G...-SST-42 | 40G             | 1454238<br>2256396  | EAMM-A-D32-40G<br>EAMM-A-D32-40G-S1 <sup>2)</sup> |
| EMMT-ST-57, EMMB-ST-57-...<br>EMGA-60-P-G...-SST-57 | 60G             | 2946758<br>2946759  | EAMM-A-D32-60G<br>EAMM-A-D32-60G-S1 <sup>2)</sup> |
| <b>With third-party gear unit</b>                   |                 |                     |   |
| Third-party gear unit                               | 40G             | 1454238<br>2256396  | EAMM-A-D32-40G<br>EAMM-A-D32-40G-S1 <sup>2)</sup> |
| Third-party gear unit                               | 50GA            | 8117072             | EAMM-A-D32-50GA                                   |
| Third-party gear unit                               | 60H             | 2946760<br>2946761  | EAMM-A-D32-60H<br>EAMM-A-D32-60H-S1 <sup>2)</sup> |

1) The input torque must not exceed the max. permissible transferable torque of the axial kit.

2) Increased degree of protection IP65

## Product range overview

## Permissible axis/motor combinations with electric cylinder ESBF

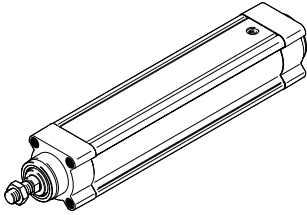

Table of interfaces for third-party motors

→ from page 64

Technical data for axial kits

→ from page 69

| Motor/gear unit <sup>1)</sup>                       | Motor interface | Axial kit |                                    |
|---|-----------------|-----------|------------------------------------|
|   |                 | Part no.  | Type                               |
| <b>ESBF-40</b>                                      |                 |           |                                    |
| <b>With servo motor</b>                             |                 |           |                                    |
| Third-party motor                                   | 55A             | 543153    | EAMM-A-D40-55A                     |
|   |                 | 1322182   | EAMM-A-D40-55A-S1 <sup>2)</sup>    |
| Third-party motor                                   | 58AA            | 8105928   | EAMM-A-D40-58AA                    |
| EMMT-AS-60-..., EMMB-AS-60-..., third-party motor   | 60P             | 8197493   | EAMM-A-D40-60P-G2                  |
|   |                 | 8197497   | EAMM-A-D40-60P-S1-G2 <sup>2)</sup> |
| Third-party motor                                   | 60R             | 8117079   | EAMM-A-D40-60R                     |
| Third-party motor                                   | 60RA            | 8117078   | EAMM-A-D40-60RA                    |
| Third-party motor                                   | 70A             | 550981    | EAMM-A-D40-70A                     |
|   |                 | 1322185   | EAMM-A-D40-70A-S1 <sup>2)</sup>    |
| Third-party motor                                   | 70AA, 70AB      | 8105952   | EAMM-A-D40-70AA                    |
| <b>With servo motor and gear unit</b>               |                 |           |                                    |
| EMME-AS-40-..., EMGA-40-P-G-...-EAS-40              | 40G             | ★ 2256398 | EAMM-A-D40-40G-G2 <sup>2)</sup>    |
|   |                 | 2256399   | EAMM-A-D40-40G-S1 <sup>2)</sup>    |
| EMMT-AS-60-..., EMGA-60-P-G-...-EAS-60              | 60H             | 1454242   | EAMM-A-D40-60H                     |
|   |                 | 2256401   | EAMM-A-D40-60H-S1 <sup>2)</sup>    |
| <b>With servo motor and right-angle gear unit</b>   |                 |           |                                    |
| EMME-AS-40-..., EMMB-AS-40-..., EMGA-40-A-G-...-40P | 40G             | ★ 2256398 | EAMM-A-D40-40G-G2 <sup>2)</sup>    |
|   |                 | 2256399   | EAMM-A-D40-40G-S1 <sup>2)</sup>    |
| EMMT-AS-60-..., EMMB-AS-60-..., EMGA-60-A-G-...-60P | 60H             | 1454242   | EAMM-A-D40-60H                     |
|   |                 | 2256401   | EAMM-A-D40-60H-S1 <sup>2)</sup>    |
| <b>With stepper motor</b>                           |                 |           |                                    |
| EMMT-ST-57, EMMB-ST-57-...                          | 57A             | ★ 543154  | EAMM-A-D40-57A                     |
|   |                 | 1322183   | EAMM-A-D40-57A-S1 <sup>2)</sup>    |
| Third-party motor                                   | 60AA            | 8105929   | EAMM-A-D40-60AA                    |
| EMMT-ST-87, EMMB-ST-87-...                          | 87A             | ★ 550982  | EAMM-A-D40-87A                     |
|   |                 | 1322186   | EAMM-A-D40-87A-S1 <sup>2)</sup>    |
| <b>With stepper motor and gear unit</b>             |                 |           |                                    |
| EMMT-ST-42, EMMB-ST-42-..., EMGA-40-P-G-...-SST-42  | 40G             | ★ 2256398 | EAMM-A-D40-40G-G2 <sup>2)</sup>    |
|   |                 | 2256399   | EAMM-A-D40-40G-S1 <sup>2)</sup>    |
| EMMT-ST-57, EMMB-ST-57-..., EMGA-60-P-G-...-SST-57  | 60G             | 2256400   | EAMM-A-D40-60G                     |
|   |                 | 2256409   | EAMM-A-D40-60G-S1 <sup>2)</sup>    |
| <b>With third-party gear unit</b>                   |                 |           |                                    |
| Third-party gear unit                               | 40G             | ★ 2256398 | EAMM-A-D40-40G-G2 <sup>2)</sup>    |
|   |                 | 2256399   | EAMM-A-D40-40G-S1 <sup>2)</sup>    |
| Third-party gear unit                               | 50GA            | 8117076   | EAMM-A-D40-50GA                    |
| Third-party gear unit                               | 60H             | 1454242   | EAMM-A-D40-60H                     |
|   |                 | 2256401   | EAMM-A-D40-60H-S1 <sup>2)</sup>    |

1) The input torque must not exceed the max. permissible transferable torque of the axial kit.

2) Increased degree of protection IP65

3) The axial kit can be retrofitted from IP40 to IP65 with the help of a seal set EADS-F → page 61.

## Product range overview

### Permissible axis/motor combinations with electric cylinder ESBF

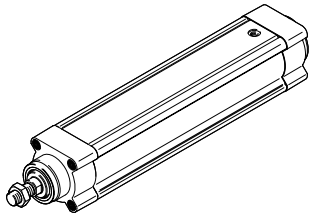

Table of interfaces for third-party motors

→ from page 64

Technical data for axial kits

→ from page 69

| Motor/gear unit <sup>1)</sup>                        | Motor interface | Axial kit            |   |
|--|-----------------|----------------------|---|
|  |                 | Part no.             | Type  |
| <b>ESBF-50</b>                                       |                 |                      |   |
| <b>With servo motor</b>                              |                 |                      |   |
| Third-party motor                                    | 70A             | 2733783<br>2734287   | EAMM-A-D50-70A<br>EAMM-A-D50-70A-S1 <sup>2)</sup>       |
| EMMT-AS-80-..., EMMB-AS-80-..., third-party motor    | 80P             | 8197489<br>8197494   | EAMM-A-D50-80P-G2<br>EAMM-A-D50-80P-S1-G2 <sup>2)</sup> |
| Third-party motor                                    | 80PB, 80R       | 8197488              | EAMM-A-D50-80PB-G2                                      |
| Third-party motor                                    | 82AA            | 8123491              | EAMM-A-D50-82AA   |
| Third-party motor                                    | 84AA            | 8123490              | EAMM-A-D50-84AA   |
| EMMT-AS-100-..., third-party motor                   | 100A            | ★ 2733784<br>2734288 | EAMM-A-D50-100A<br>EAMM-A-D50-100A-S1 <sup>2)</sup>     |
| <b>With servo motor and gear unit</b>                |                 |                      |   |
| EMMT-AS-60-...<br>EMGA-60-P-G...-EAS-60              | 60H             | 8197492<br>8197491   | EAMM-A-D50-60H-G2<br>EAMM-A-D50-60H-S1-G2 <sup>2)</sup> |
| EMMT-AS-80-...<br>EMGA-80-P-G...-EAS-80              | 80G             | 2733787<br>2734291   | EAMM-A-D50-80G<br>EAMM-A-D50-80G-S1 <sup>2)</sup>       |
| EMMT-AS-100-...<br>EMGA-80-P-G...-SAS-100            | 80G             | 2733787<br>2734291   | EAMM-A-D50-80G<br>EAMM-A-D50-80G-S1 <sup>2)</sup>       |
| <b>With servo motor and right-angle gear unit</b>    |                 |                      |   |
| EMMT-AS-60-..., EMMB-AS-60-...<br>EMGA-60-A-G...-60P | 60H             | 8197492<br>8197491   | EAMM-A-D50-60H-G2<br>EAMM-A-D50-60H-S1-G2 <sup>2)</sup> |
| EMMT-AS-80-..., EMMB-AS-80-...<br>EMGA-80-A-G...-80P | 80G             | 2733787<br>2734291   | EAMM-A-D50-80G<br>EAMM-A-D50-80G-S1 <sup>2)</sup>       |
| EMMT-AS-100-...<br>EMGA-80-A-G...-100A               | 80G             | 2733787<br>2734291   | EAMM-A-D50-80G<br>EAMM-A-D50-80G-S1 <sup>2)</sup>       |
| <b>With third-party gear unit</b>                    |                 |                      |   |
| Third-party gear unit                                | 70GA            | 8123492              | EAMM-A-D50-70GA   |
| <b>With stepper motor</b>                            |                 |                      |   |
| EMMT-ST-87, EMMB-ST-87-...                           | 87A             | ★ 2733781<br>2734286 | EAMM-A-D50-87A<br>EAMM-A-D50-87A-S1 <sup>2)</sup>       |
| <b>With stepper motor and gear unit</b>              |                 |                      |   |
| EMMT-ST-57, EMMB-ST-57-...<br>EMGA-60-P-G...-SST-57  | 60G             | 8197498<br>8197496   | EAMM-A-D50-60G-G2<br>EAMM-A-D50-60G-S1-G2 <sup>2)</sup> |
| EMMT-ST-87, EMMB-ST-87-...<br>EMGA-80-P-G...-SST-87  | 80G             | 2733787<br>2734291   | EAMM-A-D50-80G<br>EAMM-A-D50-80G-S1 <sup>2)</sup>       |
| <b>With third-party gear unit</b>                    |                 |                      |   |
| Third-party gear unit                                | 60G             | 8197498<br>8197496   | EAMM-A-D50-60G-G2<br>EAMM-A-D50-60G-S1-G2 <sup>2)</sup> |
| Third-party gear unit                                | 60H             | 8197492<br>8197491   | EAMM-A-D50-60H-G2<br>EAMM-A-D50-60H-S1-G2 <sup>2)</sup> |
| Third-party gear unit                                | 80G             | 2733787<br>2734291   | EAMM-A-D50-80G<br>EAMM-A-D50-80G-S1 <sup>2)</sup>       |

1) The input torque must not exceed the max. permissible transferable torque of the axial kit.

2) Increased degree of protection IP65



## Product range overview

## Permissible axis/motor combinations with electric cylinder ESBF

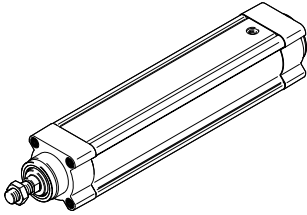

Table of interfaces for third-party motors

→ from page 64

Technical data for axial kits

→ from page 69

| Motor/gear unit <sup>1)</sup><br>Type                | Motor interface | Axial kit |                                     |
|--|-----------------|-----------|-------------------------------------|
|  |                 | Part no.  | Type                                |
| <b>ESBF-63</b>                                       |                 |           |                                     |
| <b>With servo motor</b>                              |                 |           |                                     |
| Third-party motor                                    | 70A             | 543161    | EAMM-A-D60-70A                      |
|  |                 | 2256699   | EAMM-A-D60-70A-S1 <sup>2)</sup>     |
| EMMT-AS-80-..., EMMB-AS-80-..., third-party motor    | 80P             | ★ 1977073 | EAMM-A-D60-80P                      |
|  |                 | 2218564   | EAMM-A-D60-80P-S1 <sup>2)</sup>     |
| Third-party motor                                    | 80PB, 80R       | 8105937   | EAMM-A-D60-80PB                     |
| Third-party motor                                    | 84AA            | 8105945   | EAMM-A-D60-84AA                     |
| Third-party motor                                    | 92RA            | 8159834   | EAMM-A-D60-92RA                     |
| EMMT-AS-100-..., third-party motor                   | 100A            | 8197500   | EAMM-A-D60-100A-G2                  |
|  |                 | 8197490   | EAMM-A-D60-100A-S1-G2 <sup>2)</sup> |
| <b>With servo motor and gear unit</b>                |                 |           |                                     |
| EMMT-AS-60-...<br>EMGA-60-P-G...-EAS-60              | 60H             | 1454245   | EAMM-A-D60-60H                      |
|  |                 | 2256697   | EAMM-A-D60-60H-S1 <sup>2)</sup>     |
| EMMT-AS-80-...<br>EMGA-80-P-G...-EAS-80              | 80G             | 8199480   | EAMM-A-D60-80G-G2                   |
|  |                 | 8199481   | EAMM-A-D60-80G-S1-G2 <sup>2)</sup>  |
| EMMT-AS-100-...<br>EMGA-80-P-G...-SAS-100            | 80G             | 8199480   | EAMM-A-D60-80G-G2                   |
|  |                 | 8199481   | EAMM-A-D60-80G-S1-G2 <sup>2)</sup>  |
| <b>With servo motor and right-angle gear unit</b>    |                 |           |                                     |
| EMMT-AS-60-..., EMMB-AS-60-...<br>EMGA-60-A-G...-60P | 60H             | 1454245   | EAMM-A-D60-60H                      |
|  |                 | 2256697   | EAMM-A-D60-60H-S1 <sup>2)</sup>     |
| EMMT-AS-80-..., EMMB-AS-80-...<br>EMGA-80-A-G...-80P | 80G             | 8199480   | EAMM-A-D60-80G-G2                   |
|  |                 | 8199481   | EAMM-A-D60-80G-S1-G2 <sup>2)</sup>  |
| EMMT-AS-100-...<br>EMGA-80-A-G...-100A               | 80G             | 8199480   | EAMM-A-D60-80G-G2                   |
|  |                 | 8199481   | EAMM-A-D60-80G-S1-G2 <sup>2)</sup>  |

- 1) The input torque must not exceed the max. permissible transferable torque of the axial kit.
- 2) Increased degree of protection IP65
- 3) The axial kit can be retrofitted from IP40 to IP65 with the help of a seal set EADS-F → page 110.

## Product range overview

### Permissible axis/motor combinations with electric cylinder ESBF

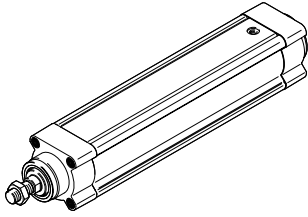

Table of interfaces for third-party motors

→ from page 64

Technical data for axial kits

→ from page 69

| Motor/gear unit <sup>1)</sup>                       | Motor interface | Axial kit |                                    |
|---|-----------------|-----------|------------------------------------|
|   |                 | Part no.  | Type                               |
| <b>ESBF-63</b>                                      |                 |           |                                    |
| <b>With stepper motor</b>                           |                 |           |                                    |
| EMMT-ST-87, EMMB-ST-87-...                          | 87A             | ★ 543162  | EAMM-A-D60-87A                     |
|   |                 | 1322188   | EAMM-A-D60-87A-S1 <sup>2)</sup>    |
| <b>With stepper motor and gear unit</b>             |                 |           |                                    |
| EMMT-ST-57, EMMB-ST-57-...<br>EMGA-60-P-G...-SST-57 | 60G             | ★ 2256696 | EAMM-A-D60-60G-G2 <sup>3)</sup>    |
|   |                 | 2256698   | EAMM-A-D60-60G-S1 <sup>2)</sup>    |
| EMMT-ST-87, EMMB-ST-87-...<br>EMGA-80-P-G...-SST-87 | 80G             | 8199480   | EAMM-A-D60-80G-G2                  |
|   |                 | 8199481   | EAMM-A-D60-80G-S1-G2 <sup>2)</sup> |
| <b>With third-party gear unit</b>                   |                 |           |                                    |
| Third-party gear unit                               | 60H             | 1454245   | EAMM-A-D60-60H                     |
|   |                 | 2256697   | EAMM-A-D60-60H-S1 <sup>2)</sup>    |
| Third-party gear unit                               | 80G             | 8199480   | EAMM-A-D60-80G-G2                  |
|   |                 | 8199481   | EAMM-A-D60-80G-S1-G2 <sup>2)</sup> |
| Third-party gear unit                               | 90GA            | 8105944   | EAMM-A-D60-90GA                    |

1) The input torque must not exceed the max. permissible transferable torque of the axial kit.

2) Increased degree of protection IP65

3) The axial kit can be retrofitted from IP40 to IP65 with the help of a seal set EADS-F → page 110.

## Product range overview

## Permissible axis/motor combinations with electric cylinder ESBF

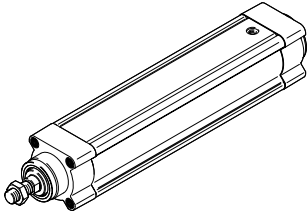

Table of interfaces for third-party motors

→ from page 64

Technical data for axial kits

→ from page 69

| Motor/gear unit <sup>1)</sup><br>Type                        | Motor interface | Axial kit      |   |
|--|-----------------|----------------|---|
|  |                 | Part no.       | Type                                    |
| <b>ESBF-80</b>   |                 |                |   |
| <b>With servo motor</b>                                      |                 |                |   |
| <b>Third-party motor</b>                                     | 84AA            | <b>8110055</b> | <b>EAMM-A-D80-84AA</b>                  |
| <b>EMMT-AS-100-..., third-party motor</b>                    | 100A            | <b>1589665</b> | <b>EAMM-A-D80-100A</b>                  |
|  |                 | <b>1600673</b> | <b>EAMM-A-D80-100A-S1<sup>2)</sup></b>  |
| <b>EMMT-AS-150</b>   | 150A            | <b>8157273</b> | <b>EAMM-A-D80-150A</b>                  |
|  |                 | <b>8157274</b> | <b>EAMM-A-D80-150A-S1<sup>2)</sup></b>  |
| <b>With servo motor and gear unit</b>                        |                 |                |   |
| <b>EMMT-AS-80-...<br/>EMGA-80-P-G...-EAS-80</b>              | 80G             | <b>2946763</b> | <b>EAMM-A-D80-80G</b>                   |
|  |                 | <b>2946764</b> | <b>EAMM-A-D80-80G-S1<sup>2)</sup></b>   |
| <b>EMMT-AS-100-...<br/>EMGA-80-P-G...-SAS-100</b>            | 80G             | <b>2946763</b> | <b>EAMM-A-D80-80G</b>                   |
|  |                 | <b>2946764</b> | <b>EAMM-A-D80-80G-S1<sup>2)</sup></b>   |
| <b>With servo motor and right-angle gear unit</b>            |                 |                |   |
| <b>EMMT-AS-80-..., EMMB-AS-80-...<br/>EMGA-80-A-G...-80P</b> | 80G             | <b>2946763</b> | <b>EAMM-A-D80-80G</b>                   |
|  |                 | <b>2946764</b> | <b>EAMM-A-D80-80G-S1<sup>2)</sup></b>   |
| <b>EMMT-AS-100-...<br/>EMGA-80-A-G...-100A</b>               | 80G             | <b>2946763</b> | <b>EAMM-A-D80-80G</b>                   |
|  |                 | <b>2946764</b> | <b>EAMM-A-D80-80G-S1<sup>2)</sup></b>   |
| <b>With stepper motor and gear unit</b>                      |                 |                |   |
| <b>EMMT-ST-87, EMMB-ST-87-...<br/>EMGA-80-P-G...-SST-87</b>  | 80G             | <b>2946763</b> | <b>EAMM-A-D80-80G</b>                   |
|  |                 | <b>2946764</b> | <b>EAMM-A-D80-80G-S1<sup>2)</sup></b>   |
| <b>With third-party gear unit</b>                            |                 |                |   |
| <b>Third-party gear unit</b>                                 | 80G             | <b>2946763</b> | <b>EAMM-A-D80-80G</b>                   |
|  |                 | <b>2946764</b> | <b>EAMM-A-D80-80G-S1<sup>2)</sup></b>   |
| <b>Third-party gear unit</b>                                 | 90GA            | <b>8110063</b> | <b>EAMM-A-D80-90GA</b>                  |
| <b>ESBF-100</b>  |                 |                |   |
| <b>With servo motor</b>                                      |                 |                |   |
| <b>EMMT-AS-100-..., third-party motor</b>                    | 100A            | <b>3356796</b> | <b>EAMM-A-D100-100A</b>                 |
|  |                 | <b>3356931</b> | <b>EAMM-A-D100-100A-S1<sup>2)</sup></b> |
| <b>EMMT-AS-150</b>   | 150A            | <b>8157275</b> | <b>EAMM-A-D100-150A</b>                 |
|  |                 | <b>8157276</b> | <b>EAMM-A-D100-150A-S1<sup>2)</sup></b> |
| <b>With servo motor and gear unit</b>                        |                 |                |   |
| <b>EMMT-AS-100-...<br/>EMGA-120-P-G...-SAS-100</b>           | 120G            | <b>2449341</b> | <b>EAMM-A-D100-120G</b>                 |
|  |                 | <b>2946765</b> | <b>EAMM-A-D100-120G-S1<sup>2)</sup></b> |
| <b>EMMT-AS-150-...<br/>EMGA-120-P-G...-SAS-140</b>           | 120G            | <b>2449341</b> | <b>EAMM-A-D100-120G</b>                 |
|  |                 | <b>2946765</b> | <b>EAMM-A-D100-120G-S1<sup>2)</sup></b> |
| <b>With third-party gear unit</b>                            |                 |                |   |
| <b>Third-party gear unit</b>                                 | 120G            | <b>2449341</b> | <b>EAMM-A-D100-120G</b>                 |
|  |                 | <b>2946765</b> | <b>EAMM-A-D100-120G-S1<sup>2)</sup></b> |

1) The input torque must not exceed the max. permissible transferable torque of the axial kit.

2) Increased degree of protection IP65

## Product range overview

### Permissible axis/motor combinations with toothed belt axis EGC-TB

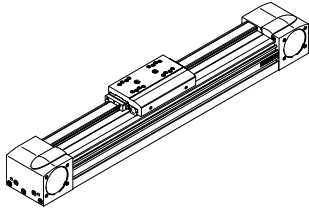

Table of interfaces for third-party motors

→ from page 64

Technical data for axial kits

→ from page 69

| Motor/gear unit <sup>1)</sup><br>Type                 | Interface<br>Motor | Axial kit |                 |
|---|--------------------|-----------|-----------------|
|   |                    | Part no.  | Type            |
| <b>EGC-50-...-TB</b>                                  |                    |           |                 |
| <b>With servo motor</b>                               |                    |           |                 |
| Third-party motor                                     | 40A                | 8063444   | EAMM-A-L27-40A  |
| Third-party motor                                     | 40R                | 8063445   | EAMM-A-L27-40R  |
| Third-party motor                                     | 40RA               | 8063446   | EAMM-A-L27-40RA |
| Third-party motor                                     | 55A                | 557975    | EAMM-A-L27-55A  |
| Third-party motor                                     | 58AA               | 8063448   | EAMM-A-L27-58AA |
| Third-party motor                                     | 60RA               | 8063452   | EAMM-A-L27-60RA |
| Third-party motor                                     | 60RB               | 8063453   | EAMM-A-L27-60RB |
| <b>With servo motor and gear unit</b>                 |                    |           |                 |
| EMME-AS-40-...<br>EMGA-40-P-G...-EAS-40               | 40G                | ★ 557974  | EAMM-A-L27-40G  |
| <b>With servo motor and right-angle gear unit</b>     |                    |           |                 |
| EMME-AS-40-... , EMMB-AS-40-...<br>EMGA-40-A-G...-40P | 40G                | ★ 557974  | EAMM-A-L27-40G  |
| <b>With stepper motor</b>                             |                    |           |                 |
| EMMT-ST-42, EMMB-ST-42-..., third-party motor         | 42A                | 8063447   | EAMM-A-L27-42A  |
| EMMT-ST-57, EMMB-ST-57-...                            | 57A                | ★ 560678  | EAMM-A-L27-57A  |
| Third-party motor                                     | 57AA               | 8063449   | EAMM-A-L27-57AA |
| Third-party motor                                     | 57AB               | 8063450   | EAMM-A-L27-57AB |
| Third-party motor                                     | 57AC               | 8063451   | EAMM-A-L27-57AC |
| <b>With stepper motor and gear unit</b>               |                    |           |                 |
| EMMT-ST-42, EMMB-ST-42-...<br>EMGA-40-P-G...-SST-42   | 40G                | ★ 557974  | EAMM-A-L27-40G  |
| EMMT-ST-57, EMMB-ST-57-...<br>EMGA-60-P-G...-SST-57   | 60G                | 8063455   | EAMM-A-L27-60G  |
| <b>With third-party gear unit</b>                     |                    |           |                 |
| Third-party gear unit                                 | 50GA               | 8063454   | EAMM-A-L27-50GA |
| Third-party gear unit                                 | 60G                | 8063455   | EAMM-A-L27-60G  |

1) The input torque must not exceed the max. permissible transferable torque of the axial kit.

## Product range overview

## Permissible axis/motor combinations with toothed belt axis EGC-TB

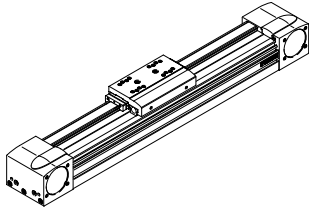

Table of interfaces for third-party motors

→ from page 64

Technical data for axial kits

→ from page 69

| Motor/gear unit <sup>1)</sup><br>Type                | Motor interface | Axial kit |                    |
|--|-----------------|-----------|--------------------|
|  |                 | Part no.  | Type               |
| <b>EGC-70-...-TB</b>                                 |                 |           |                    |
| <b>With servo motor</b>                              |                 |           |                    |
| Third-party motor                                    | 55A             | 3683331   | EAMM-A-L38-55A     |
| Third-party motor                                    | 58AA            | 8063456   | EAMM-A-L38-58AA    |
| EMMT-AS-60-..., EMMB-AS-60-..., third-party motor    | 60P, 60PA       | 8197454   | EAMM-A-L38-60P-G2  |
| Third-party motor                                    | 60R             | 8197451   | EAMM-A-L38-60R-G2  |
| Third-party motor                                    | 60RA            | 8197449   | EAMM-A-L38-60RA    |
| Third-party motor                                    | 60RB            | 8063460   | EAMM-A-L38-60RB    |
| Third-party motor                                    | 70A             | 557979    | EAMM-A-L38-70A     |
| Third-party motor                                    | 70AA, 70AB      | 8063461   | EAMM-A-L38-70AA    |
| Third-party motor                                    | 84AA            | 8063464   | EAMM-A-L38-84AA    |
| Third-party motor                                    | 88A             | 8063463   | EAMM-A-L38-88A     |
| <b>With servo motor and gear unit</b>                |                 |           |                    |
| EMME-AS-40-...<br>EMGA-40-P-G...-EAS-40              | 40G             | 8197448   | EAMM-A-L38-40G-G2  |
| EMMT-AS-60-...<br>EMGA-60-P-G...-EAS-60              | 60H             | 8197452   | EAMM-A-L38-60H-G2  |
| <b>With servo motor and right-angle gear unit</b>    |                 |           |                    |
| EMMT-AS-60-..., EMMB-AS-60-...<br>EMGA-60-A-G...-60P | 60H             | 8197452   | EAMM-A-L38-60H-G2  |
| <b>With stepper motor</b>                            |                 |           |                    |
| EMMT-ST-57, EMMB-ST-57-...                           | 57A             | 8197461   | EAMM-A-L38-57A-G2  |
| Third-party motor                                    | 57AA            | 8063457   | EAMM-A-L38-57AA    |
| Third-party motor                                    | 60AA            | 8107702   | EAMM-A-L38-60AA    |
| EMMT-ST-87, EMMB-ST-87-...                           | 87A             | 8197447   | EAMM-A-L38-87A-G2  |
| <b>With stepper motor and gear unit</b>              |                 |           |                    |
| EMMT-ST-42, EMMB-ST-42-...<br>EMGA-40-P-G...-SST-42  | 40G             | 8197448   | EAMM-A-L38-40G-G2  |
| EMMT-ST-57, EMMB-ST-57-...<br>EMGA-60-P-G...-SST-57  | 60G             | 8197460   | EAMM-A-L38-60G-G2  |
| <b>With third-party gear unit</b>                    |                 |           |                    |
| Third-party gear unit                                | 40G             | 8197448   | EAMM-A-L38-40G-G2  |
| Third-party gear unit                                | 50GA            | 8063466   | EAMM-A-L38-50GA    |
| Third-party gear unit                                | 56GA            | 8063467   | EAMM-A-L38-56GA    |
| Third-party gear unit                                | 68GA            | 8063469   | EAMM-A-L38-68GA    |
| Third-party gear unit                                | 70GA            | 8199483   | EAMM-A-L38-70GA-G2 |
| Third-party gear unit                                | 72GA            | 8063470   | EAMM-A-L38-72GA    |

1) The input torque must not exceed the max. permissible transferable torque of the axial kit.

## Product range overview

### Permissible axis/motor combinations with toothed belt axis EGC-TB

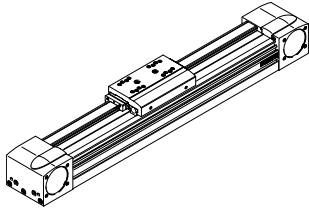

Table of interfaces for third-party motors

→ from page 64

Technical data for axial kits

→ from page 69

| Motor/gear unit <sup>1)</sup>                        | Motor interface | Axial kit |                    |
|--|-----------------|-----------|--------------------|
|  |                 | Part no.  | Type               |
| <b>EGC-80-...-TB</b>                                 |                 |           |                    |
| <b>With servo motor</b>                              |                 |           |                    |
| Third-party motor                                    | 55A             | 8063471   | EAMM-A-L48-55A     |
| Third-party motor                                    | 60P, 60PA       | 8197450   | EAMM-A-L48-60P     |
| Third-party motor                                    | 70A             | 557982    | EAMM-A-L48-70A     |
| Third-party motor                                    | 70AA, 70AB      | 8063473   | EAMM-A-L48-70AA    |
| EMMT-AS-80-..., EMMB-AS-80-..., third-party motor    | 80P             | ★ 8164277 | EAMM-A-L48-80P-G2  |
| Third-party motor                                    | 80PB            | 8123168   | EAMM-A-L48-80PB    |
| Third-party motor                                    | 82AA            | 8063475   | EAMM-A-L48-82AA    |
| Third-party motor                                    | 84AA            | 8063479   | EAMM-A-L48-84AA    |
| Third-party motor                                    | 88A             | 8063476   | EAMM-A-L48-88A     |
| Third-party motor                                    | 90R             | 8063477   | EAMM-A-L48-90R     |
| Third-party motor                                    | 92RA            | 8063478   | EAMM-A-L48-92RA    |
| EMMT-AS-100-..., third-party motor                   | 100A            | ★ 8164278 | EAMM-A-L48-100A-G2 |
| <b>With servo motor and gear unit</b>                |                 |           |                    |
| EMME-AS-40-...<br>EMGA-40-P-G...-EAS-40              | 40G             | 8063480   | EAMM-A-L48-40G     |
| EMMT-AS-60-...<br>EMGA-60-P-G...-EAS-60              | 60H             | 8197458   | EAMM-A-L48-60H-G2  |
| EMMT-AS-80-...<br>EMGA-80-P-G...-EAS-80              | 80G             | 8197455   | EAMM-A-L48-80G-G2  |
| EMMT-AS-100-...<br>EMGA-80-P-G...-SAS-100            | 80G             | 8197455   | EAMM-A-L48-80G-G2  |
| <b>With servo motor and right-angle gear unit</b>    |                 |           |                    |
| EMME-AS-40-..., EMMB-AS-40-...<br>EMGA-40-A-G...-40P | 40G             | 8063480   | EAMM-A-L48-40G     |
| EMMT-AS-60-..., EMMB-AS-60-...<br>EMGA-60-A-G...-60P | 60H             | 8197458   | EAMM-A-L48-60H-G2  |
| EMMT-AS-80-..., EMMB-AS-80-...<br>EMGA-80-A-G...-80P | 80G             | 8197455   | EAMM-A-L48-80G-G2  |
| EMMT-AS-100-...<br>EMGA-80-A-G...-100A               | 80G             | 8197455   | EAMM-A-L48-80G-G2  |

1) The input torque must not exceed the max. permissible transferable torque of the axial kit.

## Product range overview

## Permissible axis/motor combinations with toothed belt axis EGC-TB

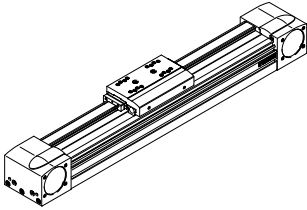

Table of interfaces for third-party motors

→ from page 64

Technical data for axial kits

→ from page 69

| Motor/gear unit <sup>1)</sup><br>Type               | Motor interface | Axial kit |                    |
|---|-----------------|-----------|--------------------|
|   |                 | Part no.  | Type               |
| <b>With stepper motor</b>                           |                 |           |                    |
| EMMT-ST-87, EMMB-ST-87-...                          | 87A             | 8197459   | EAMM-A-L48-87A-G2  |
| <b>With stepper motor and gear unit</b>             |                 |           |                    |
| EMMT-ST-57, EMMB-ST-57-...<br>EMGA-60-P-G...-SST-57 | 60G             | 8197457   | EAMM-A-L48-60G-G2  |
| EMMT-ST-87, EMMB-ST-87-...<br>EMGA-80-P-G...-SST-87 | 80G             | 8197455   | EAMM-A-L48-80G-G2  |
| <b>With third-party gear unit</b>                   |                 |           |                    |
| Third-party gear unit                               | 40G             | 8063480   | EAMM-A-L48-40G     |
| Third-party gear unit                               | 50GA            | 8188639   | EAMM-A-L48-50GA-G2 |
| Third-party gear unit                               | 56GA            | 8063482   | EAMM-A-L48-56GA    |
| Third-party gear unit                               | 68GA            | 8063486   | EAMM-A-L48-68GA    |
| Third-party gear unit                               | 70GA            | 8188640   | EAMM-A-L48-70GA-G2 |
| Third-party gear unit                               | 72GA            | 8063487   | EAMM-A-L48-72GA    |
| Third-party gear unit                               | 75GA            | 8063484   | EAMM-A-L48-75GA    |
| Third-party gear unit                               | 80G             | 8197455   | EAMM-A-L48-80G-G2  |
| Third-party gear unit                               | 90GA            | 8063489   | EAMM-A-L48-90GA    |
| Third-party gear unit                               | 90GB            | 8063488   | EAMM-A-L48-90GB    |
| Third-party gear unit                               | 120GA           | 8063490   | EAMM-A-L48-120GA   |

1) The input torque must not exceed the max. permissible transferable torque of the axial kit.

## Product range overview

### Permissible axis/motor combinations with toothed belt axis EGC-TB

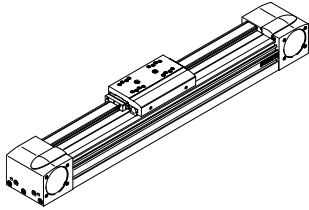

Table of interfaces for third-party motors

→ from page 64

Technical data for axial kits

→ from page 69

| Motor/gear unit <sup>1)</sup>                        | Motor interface | Axial kit |                    |
|--|-----------------|-----------|--------------------|
|  |                 | Part no.  | Type               |
| <b>EGC-120-...-TB</b>                                |                 |           |                    |
| <b>With servo motor</b>                              |                 |           |                    |
| Third-party motor                                    | 84AA            | 8063493   | EAMM-A-L62-84AA    |
| Third-party motor                                    | 88A             | 8063492   | EAMM-A-L62-88A     |
| EMMT-AS-100-..., third-party motor                   | 100A            | ★ 8164276 | EAMM-A-L62-100A-G2 |
| Third-party motor                                    | 108AA           | 8063494   | EAMM-A-L62-108AA   |
| EMMT-AS-150-...                                      | 150A            | 8157270   | EAMM-A-L62-150A    |
| <b>With servo motor and gear unit</b>                |                 |           |                    |
| EMMT-AS-60-...<br>EMGA-60-P-G...-EAS-60              | 60H             | 8063498   | EAMM-A-L62-60H     |
| EMMT-AS-80-...<br>EMGA-80-P-G...-EAS-80              | 80G             | 8197456   | EAMM-A-L62-80G-G2  |
| EMMT-AS-100-...<br>EMGA-80-P-G...-SAS-100            | 80G             | 8197456   | EAMM-A-L62-80G-G2  |
| <b>With servo motor and right-angle gear unit</b>    |                 |           |                    |
| EMMT-AS-60-..., EMMB-AS-60-...<br>EMGA-60-A-G...-60P | 60H             | 8063498   | EAMM-A-L62-60H     |
| EMMT-AS-80-..., EMMB-AS-80-...<br>EMGA-80-A-G...-80P | 80G             | 8197456   | EAMM-A-L62-80G-G2  |
| EMMT-AS-100-...<br>EMGA-80-A-G...-100A               | 80G             | 8197456   | EAMM-A-L62-80G-G2  |
| <b>With stepper motor and gear unit</b>              |                 |           |                    |
| EMMT-ST-87, EMMB-ST-87-...<br>EMGA-80-P-G...-SST-87  | 80G             | 8197456   | EAMM-A-L62-80G-G2  |
| <b>With third-party gear unit</b>                    |                 |           |                    |
| Third-party gear unit                                | 56GA            | 8063497   | EAMM-A-L62-56GA    |
| Third-party gear unit                                | 60H             | 8063498   | EAMM-A-L62-60H     |
| Third-party gear unit                                | 68GA            | 8063502   | EAMM-A-L62-68GA    |
| Third-party gear unit                                | 70GA            | 8063499   | EAMM-A-L62-70GA    |
| Third-party gear unit                                | 72GA            | 8063503   | EAMM-A-L62-72GA    |
| Third-party gear unit                                | 75GA            | 8063500   | EAMM-A-L62-75GA    |
| Third-party gear unit                                | 80G             | 8197456   | EAMM-A-L62-80G-G2  |
| Third-party gear unit                                | 90GA            | 8063505   | EAMM-A-L62-90GA    |
| Third-party gear unit                                | 90GB            | 8063504   | EAMM-A-L62-90GB    |
| Third-party gear unit                                | 115GA           | 8063506   | EAMM-A-L62-115GA   |
| Third-party gear unit                                | 120G            | 8063507   | EAMM-A-L62-120G    |
| Third-party gear unit                                | 120GA           | 8063508   | EAMM-A-L62-120GA   |
| Third-party gear unit                                | 120GB           | 8063509   | EAMM-A-L62-120GB   |
| Third-party gear unit                                | 120GC           | 8063510   | EAMM-A-L62-120GC   |

1) The input torque must not exceed the max. permissible transferable torque of the axial kit.



## Product range overview

## Permissible axis/motor combinations with toothed belt axis EGC-TB

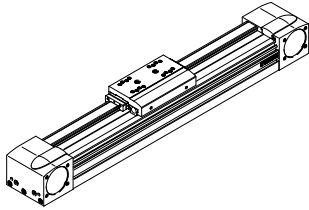

Table of interfaces for third-party motors

→ from page 64

Technical data for axial kits

→ from page 69

| Motor/gear unit <sup>1)</sup><br>Type                | Motor interface | Axial kit |                    |
|--|-----------------|-----------|--------------------|
|  |                 | Part no.  | Type               |
| <b>EGC-185-...-TB</b>                                |                 |           |                    |
| <b>With servo motor</b>                              |                 |           |                    |
| EMMT-AS-150-...                                      | 150A            | 8157280   | EAMM-A-L95-150A-G2 |
| EMMT-AS-190-...                                      | 190B            | 8157282   | EAMM-A-L95-190B-G2 |
| <b>With servo motor and gear unit</b>                |                 |           |                    |
| EMMT-AS-80-...<br>EMGA-80-P-G...-EAS-80              | 80G             | 3660191   | EAMM-A-L95-80G-G2  |
| EMMT-AS-100-...<br>EMGA-80-P-G...-SAS-100            | 80G             | 3660191   | EAMM-A-L95-80G-G2  |
| EMMT-AS-100-...<br>EMGA-120-P-G...-SAS-100           | 120G            | ★ 3659941 | EAMM-A-L95-120G-G2 |
| EMMT-AS-150-...<br>EMGA-120-P-G...-SAS-140           | 120G            | ★ 3659941 | EAMM-A-L95-120G-G2 |
| <b>With servo motor and right-angle gear unit</b>    |                 |           |                    |
| EMMT-AS-80-..., EMMB-AS-80-...<br>EMGA-80-A-G...-80P | 80G             | 3660191   | EAMM-A-L95-80G-G2  |
| EMMT-AS-100-...<br>EMGA-80-A-G...-100A               | 80G             | 3660191   | EAMM-A-L95-80G-G2  |
| <b>With third-party gear unit</b>                    |                 |           |                    |
| Third-party gear unit                                | 68GA            | 8063524   | EAMM-A-L95-68GA    |
| Third-party gear unit                                | 72GA            | 8063525   | EAMM-A-L95-72GA    |
| Third-party gear unit                                | 75GA            | 8063522   | EAMM-A-L95-75GA    |
| Third-party gear unit                                | 80G             | 3660191   | EAMM-A-L95-80G-G2  |
| Third-party gear unit                                | 90GA            | 8063526   | EAMM-A-L95-90GA    |
| Third-party gear unit                                | 115GA           | 8063527   | EAMM-A-L95-115GA   |
| Third-party gear unit                                | 120G            | ★ 3659941 | EAMM-A-L95-120G-G2 |
| Third-party gear unit                                | 120GA           | 8063529   | EAMM-A-L95-120GA   |
| Third-party gear unit                                | 120GB           | 8063530   | EAMM-A-L95-120GB   |
| Third-party gear unit                                | 120GC           | 8063531   | EAMM-A-L95-120GC   |
| Third-party gear unit                                | 160G            | 8197453   | EAMM-A-L95-160G-G2 |

1) The input torque must not exceed the max. permissible transferable torque of the axial kit.

## Product range overview

### Permitted axis/motor combinations with ball screw axis EGC-BS

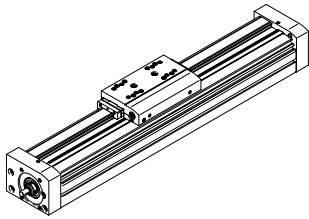

Table of interfaces for third-party motors

→ from page 64

Technical data for axial kits

→ from page 69

| Motor/gear unit <sup>1)</sup>                        | Motor interface | Axial kit |                    |
|--|-----------------|-----------|--------------------|
|  |                 | Part no.  | Type               |
| <b>EGC-70-...-BS</b>                                 |                 |           |                    |
| <b>With servo motor</b>                              |                 |           |                    |
| EMME-AS-40-..., EMMB-AS-40-...                       | 40P             | ★ 3637972 | EAMM-A-S38-40P-G2  |
| Third-party motor                                    | 40A             | 3637971   | EAMM-A-S38-40A-G2  |
| Third-party motor                                    | 55A             | 8197483   | EAMM-A-S38-55A-G3  |
| Third-party motor                                    | 58AA            | 8105927   | EAMM-A-S38-58AA    |
| EMMT-AS-60-..., EMMB-AS-60-..., third-party motor    | 60P             | 8197479   | EAMM-A-S38-60P-G3  |
| Third-party motor                                    | 60R             | 8197475   | EAMM-A-S38-60R-G2  |
| Third-party motor                                    | 60RA            | 8197484   | EAMM-A-S38-60RA-G2 |
| <b>With servo motor and gear unit</b>                |                 |           |                    |
| EMME-AS-40-...<br>EMGA-40-P-G...-EAS-40              | 40G             | 1456647   | EAMM-A-S38-40G-G2  |
| <b>With servo motor and right-angle gear unit</b>    |                 |           |                    |
| EMME-AS-40-..., EMMB-AS-40-...<br>EMGA-40-A-G...-40P | 40G             | 1456647   | EAMM-A-S38-40G-G2  |
| <b>With stepper motor</b>                            |                 |           |                    |
| EMMT-ST-42, EMMB-ST-42-..., third-party motor        | 42A             | ★ 3637965 | EAMM-A-S38-42A-G2  |
| EMMT-ST-42, EMMB-ST-57-...                           | 57A             | ★ 3637956 | EAMM-A-S38-57A-G2  |
| Third-party motor                                    | 60AA            | 8105926   | EAMM-A-S38-60AA    |
| <b>With stepper motor and gear unit</b>              |                 |           |                    |
| EMMT-ST-42, EMMB-ST-42-...<br>EMGA-40-P-G...-SST-42  | 40G             | 1456647   | EAMM-A-S38-40G-G2  |
| <b>With third-party gear unit</b>                    |                 |           |                    |
| Third-party gear unit                                | 40G             | 1456647   | EAMM-A-S38-40G-G2  |
| Third-party gear unit                                | 50GA            | 8105922   | EAMM-A-S38-50GA    |

1) The input torque must not exceed the max. permissible transferable torque of the axial kit.

## Product range overview

## Permitted axis/motor combinations with ball screw axis EGC-BS

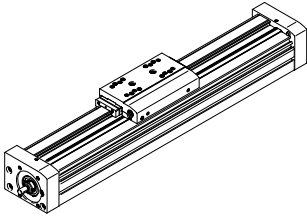

Table of interfaces for third-party motors

→ from page 64

Technical data for axial kits

→ from page 69

| Motor/gear unit <sup>1)</sup><br>Type                | Motor interface | Axial kit |                    |
|--|-----------------|-----------|--------------------|
|  |                 | Part no.  | Type               |
| <b>EGC-80-...-BS</b>                                 |                 |           |                    |
| <b>With servo motor</b>                              |                 |           |                    |
| Third-party motor                                    | 55A             | 3637961   | EAMM-A-S48-55A-G2  |
| Third-party motor                                    | 58AA            | 8105933   | EAMM-A-S48-58AA    |
| EMMT-AS-60-..., EMMB-AS-60-..., third-party motor    | 60P             | 8197481   | EAMM-A-S48-60P-G3  |
| Third-party motor                                    | 60R             | 8197485   | EAMM-A-S48-60R-G2  |
| Third-party motor                                    | 60RA            | 8197474   | EAMM-A-S48-60RA-G2 |
| Third-party motor                                    | 70A             | 3637957   | EAMM-A-S48-70A-G2  |
| Third-party motor                                    | 70AA, 70AB      | 8105942   | EAMM-A-S48-70AA    |
| EMMT-AS-80-..., EMMB-AS-80-..., third-party motor    | 80P, 80PA, 80RA | 8197480   | EAMM-A-S48-80P     |
| Third-party motor                                    | 80PB, 80R       | 8197487   | EAMM-A-S48-80PB    |
| <b>With servo motor and gear unit</b>                |                 |           |                    |
| EMME-AS-40-...<br>EMGA-40-P-G...-EAS-40              | 40G             | 1456650   | EAMM-A-S48-40G-G2  |
| EMMT-AS-60-...<br>EMGA-60-P-G...-EAS-60              | 60H             | 8197482   | EAMM-A-S48-60H-G3  |
| <b>With servo motor and right-angle gear unit</b>    |                 |           |                    |
| EMME-AS-40-..., EMMB-AS-40-...<br>EMGA-40-A-G...-40P | 40G             | 1456650   | EAMM-A-S48-40G-G2  |
| EMMT-AS-60-..., EMMB-AS-60-...<br>EMGA-60-A-G...-60P | 60H             | 8197482   | EAMM-A-S48-60H-G3  |
| <b>With stepper motor</b>                            |                 |           |                    |
| EMMT-ST-57, EMMB-ST-57-...<br>Third-party motor      | 57A             | ★ 3637963 | EAMM-A-S48-57A-G2  |
| Third-party motor                                    | 60AA            | 8105935   | EAMM-A-S48-60AA    |
| EMMT-ST-87, EMMB-ST-87-...<br>Third-party motor      | 87A             | ★ 3637962 | EAMM-A-S48-87A-G2  |
| <b>With stepper motor and gear unit</b>              |                 |           |                    |
| EMMT-ST-42, EMMB-ST-42-...<br>EMGA-40-P-G...-SST-42  | 40G             | 1456650   | EAMM-A-S48-40G-G2  |
| EMMT-ST-57, EMMB-ST-57-...<br>EMGA-60-P-G...-SST-57  | 60G             | 8197477   | EAMM-A-S48-60G-G3  |
| <b>With third-party gear unit</b>                    |                 |           |                    |
| Third-party gear unit                                | 40G             | 1456650   | EAMM-A-S48-40G-G2  |
| Third-party gear unit                                | 50GA            | 8105930   | EAMM-A-S48-50GA    |
| Third-party gear unit                                | 60H             | 8197482   | EAMM-A-S48-60H-G3  |

1) The input torque must not exceed the max. permissible transferable torque of the axial kit.

## Product range overview

### Permitted axis/motor combinations with ball screw axis EGC-BS

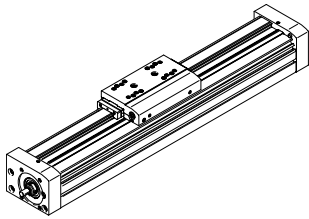

Table of interfaces for third-party motors

→ from page 64

Technical data for axial kits

→ from page 69

| Motor/gear unit <sup>1)</sup><br>Type                | Motor interface | Axial kit |                    |
|--|-----------------|-----------|--------------------|
|  |                 | Part no.  | Type               |
| <b>EGC-120-...-BS</b>                                |                 |           |                    |
| <b>With servo motor</b>                              |                 |           |                    |
| Third-party motor                                    | 70A             | 3637959   | EAMM-A-S62-70A-G2  |
| EMMT-AS-80-..., EMMB-AS-80-..., third-party motor    | 80P             | ★ 3637970 | EAMM-A-S62-80P-G2  |
| Third-party motor                                    | 80PB, 80R       | 8110208   | EAMM-A-S62-80PB    |
| Third-party motor                                    | 82AA            | 8110211   | EAMM-A-S62-82AA    |
| Third-party motor                                    | 84AA            | 8110226   | EAMM-A-S62-84AA    |
| EMMT-AS-100-..., third-party motor                   | 100A            | 8197486   | EAMM-A-S62-100A-G3 |
| EMMT-AS-150  | 150A            | 8157272   | EAMM-A-S62-150A-G2 |
| <b>With servo motor and gear unit</b>                |                 |           |                    |
| EMMT-AS-60-...<br>EMGA-60-P-G...-EAS-60              | 60H             | 1456654   | EAMM-A-S62-60H-G2  |
| EMMT-AS-80-...<br>EMGA-80-P-G...-EAS-80              | 80G             | 8197473   | EAMM-A-S62-80G-G3  |
| EMMT-AS-100-...<br>EMGA-80-P-G...-SAS-100            | 80G             | 8197473   | EAMM-A-S62-80G-G3  |
| <b>With servo motor and right-angle gear unit</b>    |                 |           |                    |
| EMMT-AS-60-..., EMMB-AS-60-...<br>EMGA-60-A-G...-60P | 60H             | 1456654   | EAMM-A-S62-60H-G2  |
| EMMT-AS-80-..., EMMB-AS-80-...<br>EMGA-80-A-G...-80P | 80G             | 8197473   | EAMM-A-S62-80G-G3  |
| EMMT-AS-100-...<br>EMGA-80-A-G...-100A               | 80G             | 8197473   | EAMM-A-S62-80G-G3  |

1) The input torque must not exceed the max. permissible transferable torque of the axial kit.

## Product range overview

## Permitted axis/motor combinations with ball screw axis EGC-BS

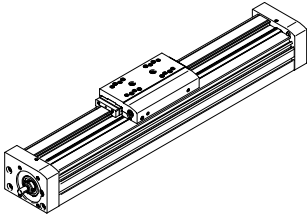

Table of interfaces for third-party motors

→ from page 64

Technical data for axial kits

→ from page 69

| Motor/gear unit <sup>1)</sup><br>Type               | Motor interface | Axial kit |                    |
|---|-----------------|-----------|--------------------|
|   |                 | Part no.  | Type               |
| <b>EGC-120-...-BS</b>                               |                 |           |                    |
| <b>With stepper motor</b>                           |                 |           |                    |
| EMMT-ST-87, EMMB-ST-87-...                          | 87A             | ★ 3637966 | EAMM-A-S62-87A-G2  |
| <b>With stepper motor and gear unit</b>             |                 |           |                    |
| EMMT-ST-57, EMMB-ST-57-...<br>EMGA-60-P-G...-SST-57 | 60G             | 2297649   | EAMM-A-S62-60G-G2  |
| EMMT-ST-87, EMMB-ST-87-...<br>EMGA-80-P-G...-SST-87 | 80G             | 8197473   | EAMM-A-S62-80G-G3  |
| <b>With third-party gear unit</b>                   |                 |           |                    |
| Third-party gear unit                               | 60H             | 1456654   | EAMM-A-S62-60H-G2  |
| Third-party gear unit                               | 70GA            | 8110082   | EAMM-A-S62-70GA    |
| Third-party gear unit                               | 80G             | 8197473   | EAMM-A-S62-80G-G3  |
| <b>EGC-185-...-BS</b>                               |                 |           |                    |
| <b>With servo motor</b>                             |                 |           |                    |
| Third-party motor                                   | 84AA            | 8107720   | EAMM-A-S95-84AA    |
| EMMT-AS-100-..., third-party motor                  | 100A            | 3637955   | EAMM-A-S95-100A-G2 |
| EMMT-AS-150   | 150A            | 8157279   | EAMM-A-S95-150A-G2 |
| <b>With servo motor and gear unit</b>               |                 |           |                    |
| EMMT-AS-80-...<br>EMGA-80-P-G...-EAS-80             | 80G             | 8197478   | EAMM-A-S95-80G     |
| EMMT-AS-100-...<br>EMGA-80-P-G...-SAS-100           | 80G             | 8197478   | EAMM-A-S95-80G     |
| EMMT-AS-100-...<br>EMGA-120-P-G...-SAS-100          | 120G            | 8197476   | EAMM-A-S95-120G    |
| EMMT-AS-150-...<br>EMGA-120-P-G...-SAS-140          | 120G            | 8197476   | EAMM-A-S95-120G    |
| <b>With third-party gear unit</b>                   |                 |           |                    |
| Third-party gear unit                               | 90GA            | 8110066   | EAMM-A-S95-90GA    |

1) The input torque must not exceed the max. permissible transferable torque of the axial kit.

## Product range overview

### Permissible axis/motor combinations with toothed belt axis ELGD-TB-...

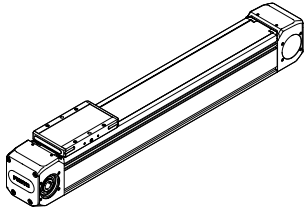

Table of interfaces for third-party motors

→ from page 64

Technical data for axial kits

→ from page 69

| Motor/gear unit <sup>1)</sup>                                | Motor interface | Axial kit      |                           |
|--|-----------------|----------------|---------------------------|
|  |                 | Part no.       | Type                      |
| <b>ELGD-TB-...-60</b>  |                 |                |                           |
| <b>With servo motor</b>                                      |                 |                |                           |
| <b>EMMT-AS-60-..., EMMB-AS-60-..., third-party motor</b>     | 60P, 60PA       | <b>8197468</b> | <b>EAMM-A-N48-60P</b>     |
| <b>Third-party motor</b>                                     | 70AA            | <b>8063591</b> | <b>EAMM-A-N48-70AA</b>    |
| <b>EMMT-AS-80-..., EMMB-AS-80-..., third-party motor</b>     | 80P             | <b>8063592</b> | <b>EAMM-A-N48-80P</b>     |
| <b>Third-party motor</b>                                     | 80PB            | <b>8107714</b> | <b>EAMM-A-N48-80PB</b>    |
| <b>Third-party motor</b>                                     | 84AA            | <b>8063594</b> | <b>EAMM-A-N48-84AA</b>    |
| <b>Third-party motor</b>                                     | 88A             | <b>8063593</b> | <b>EAMM-A-N48-88A</b>     |
| <b>EMMT-AS-100-..., third-party motor</b>                    | 100A            | <b>8197464</b> | <b>EAMM-A-N48-100A-G2</b> |
| <b>With servo motor and gear unit</b>                        |                 |                |                           |
| <b>EMME-AS-40-...<br/>EMGA-40-P-G...-EAS-40</b>              | 40G             | <b>8197467</b> | <b>EAMM-A-N48-40G</b>     |
| <b>EMMT-AS-60-...<br/>EMGA-60-P-G...-EAS-60</b>              | 60H             | <b>8197465</b> | <b>EAMM-A-N48-60H-G2</b>  |
| <b>EMMT-AS-80-...<br/>EMGA-80-P-G...-EAS-80</b>              | 80G             | <b>8197470</b> | <b>EAMM-A-N48-80G-G2</b>  |
| <b>EMMT-AS-100-...<br/>EMGA-80-P-G...-SAS-100</b>            | 80G             | <b>8197470</b> | <b>EAMM-A-N48-80G-G2</b>  |
| <b>With servo motor and right-angle gear unit</b>            |                 |                |                           |
| <b>EMMT-AS-60-..., EMMB-AS-60-...<br/>EMGA-60-A-G...-60P</b> | 60H             | <b>8197465</b> | <b>EAMM-A-N48-60H-G2</b>  |
| <b>EMMT-AS-80-..., EMMB-AS-80-...<br/>EMGA-80-A-G...-80P</b> | 80G             | <b>8197470</b> | <b>EAMM-A-N48-80G-G2</b>  |
| <b>EMMT-AS-100-...<br/>EMGA-80-A-G...-100A</b>               | 80G             | <b>8197470</b> | <b>EAMM-A-N48-80G-G2</b>  |

1) The input torque must not exceed the max. permissible transferable torque of the axial kit.

## Product range overview

## Permissible axis/motor combinations with toothed belt axis ELGD-TB-...

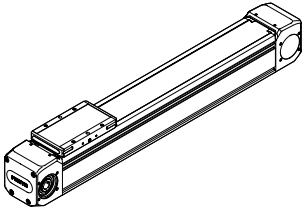

Table of interfaces for third-party motors

→ from page 64

Technical data for axial kits

→ from page 69

| Motor/gear unit <sup>1)</sup><br>Type               | Motor interface | Axial kit |                    |
|---|-----------------|-----------|--------------------|
|   |                 | Part no.  | Type               |
| <b>ELGD-TB-...-60</b>                               |                 |           |                    |
| <b>With stepper motor</b>                           |                 |           |                    |
| EMMT-ST-87, EMMB-ST-87-...                          | 87A             | 8197466   | EAMM-A-N48-87A     |
| <b>With stepper motor and gear unit</b>             |                 |           |                    |
| EMMT-ST-57, EMMB-ST-57-...<br>EMGA-60-P-G...-SST-57 | 60G             | 8197469   | EAMM-A-N48-60G-G2  |
| EMMT-ST-87, EMMB-ST-87-...<br>EMGA-80-P-G...-SST-87 | 80G             | 8197470   | EAMM-A-N48-80G-G2  |
| <b>With third-party gear unit</b>                   |                 |           |                    |
| Third-party gear unit                               | 50GA            | 8063595   | EAMM-A-N48-50GA    |
| Third-party gear unit                               | 56GA            | 8063596   | EAMM-A-N48-56GA    |
| Third-party gear unit                               | 60H             | 8197465   | EAMM-A-N48-60H-G2  |
| Third-party gear unit                               | 68GA            | 8063600   | EAMM-A-N48-68GA    |
| Third-party gear unit                               | 70GA            | 8199479   | EAMM-A-N48-70GA-G2 |
| Third-party gear unit                               | 72GA            | 8063601   | EAMM-A-N48-72GA    |
| Third-party gear unit                               | 75GA            | 8063598   | EAMM-A-N48-75GA    |
| Third-party gear unit                               | 80G             | 8197470   | EAMM-A-N48-80G-G2  |
| Third-party gear unit                               | 90GA            | 8063603   | EAMM-A-N48-90GA    |
| Third-party gear unit                               | 90GB            | 8063602   | EAMM-A-N48-90GB    |
| Third-party gear unit                               | 120GA           | 8063605   | EAMM-A-N48-120GA   |

1) The input torque must not exceed the max. permissible transferable torque of the axial kit.

## Product range overview

### Permissible axis/motor combinations with toothed belt axis ELGD-TB-...

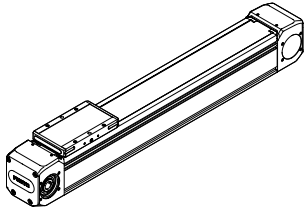

Table of interfaces for third-party motors

→ from page 64

Technical data for axial kits

→ from page 69

| Motor/gear unit <sup>1)</sup>                     | Motor interface | Axial kit |                   |
|---|-----------------|-----------|-------------------|
|   |                 | Part no.  | Type              |
| <b>ELGD-TB-...-80</b>                             |                 |           |                   |
| <b>With servo motor</b>                           |                 |           |                   |
| Third-party motor                                 | 55A             | 8063471   | EAMM-A-L48-55A    |
| Third-party motor                                 | 60P, 60PA       | 8197450   | EAMM-A-L48-60P    |
| Third-party motor                                 | 70A             | 557982    | EAMM-A-L48-70A    |
| Third-party motor                                 | 70AA, 70AB      | 8063473   | EAMM-A-L48-70AA   |
| EMMT-AS-80-..., EMMB-AS-80-..., third-party motor | 80P             | ★ 8164277 | EAMM-A-L48-80P-G2 |
| Third-party motor                                 | 80PB            | 8123168   | EAMM-A-L48-80PB   |
| Third-party motor                                 | 82AA            | 8063475   | EAMM-A-L48-82AA   |
| Third-party motor                                 | 84AA            | 8063479   | EAMM-A-L48-84AA   |
| Third-party motor                                 | 88A             | 8063476   | EAMM-A-L48-88A    |
| Third-party motor                                 | 90R             | 8063477   | EAMM-A-L48-90R    |
| Third-party motor                                 | 92RA            | 8063478   | EAMM-A-L48-92RA   |
| <b>With servo motor and gear unit</b>             |                 |           |                   |
| EMME-AS-40-..., EMMB-AS-40-...                    | 40G             | 8063480   | EAMM-A-L48-40G    |
| EMGA-40-P-G...-EAS-40                             |                 |           |                   |
| EMMT-AS-60-..., EMMB-AS-60-...                    | 60H             | 8197458   | EAMM-A-L48-60H-G2 |
| EMGA-60-P-G...-EAS-60                             |                 |           |                   |
| EMMT-AS-80-..., EMMB-AS-80-...                    | 80G             | 8197455   | EAMM-A-L48-80G-G2 |
| EMGA-80-P-G...-EAS-80                             |                 |           |                   |
| EMMT-AS-100-..., EMMB-AS-100-...                  | 80G             | 8197455   | EAMM-A-L48-80G-G2 |
| EMGA-80-P-G...-SAS-100                            |                 |           |                   |
| <b>With servo motor and right-angle gear unit</b> |                 |           |                   |
| EMME-AS-40-..., EMMB-AS-40-...                    | 40G             | 8063480   | EAMM-A-L48-40G    |
| EMGA-40-A-G...-40P                                |                 |           |                   |
| EMMT-AS-60-..., EMMB-AS-60-...                    | 60H             | 8197458   | EAMM-A-L48-60H-G2 |
| EMGA-60-A-G...-60P                                |                 |           |                   |
| EMMT-AS-80-..., EMMB-AS-80-...                    | 80G             | 8197455   | EAMM-A-L48-80G-G2 |
| EMGA-80-A-G...-80P                                |                 |           |                   |
| EMMT-AS-100-..., EMMB-AS-100-...                  | 80G             | 8197455   | EAMM-A-L48-80G-G2 |
| EMGA-80-A-G...-100A                               |                 |           |                   |

1) The input torque must not exceed the max. permissible transferable torque of the axial kit.



## Product range overview

## Permissible axis/motor combinations with toothed belt axis ELGD-TB-...

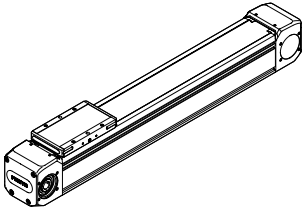

Table of interfaces for third-party motors

→ from page 64

Technical data for axial kits

→ from page 69

| Motor/gear unit <sup>1)</sup><br>Type               | Motor interface | Axial kit |                    |
|---|-----------------|-----------|--------------------|
|   |                 | Part no.  | Type               |
| <b>ELGD-TB-...-80</b>                               |                 |           |                    |
| <b>With stepper motor</b>                           |                 |           |                    |
| EMMT-ST-87, EMMB-ST-87-...                          | 87A             | 8197459   | EAMM-A-L48-87A-G2  |
| <b>With stepper motor and gear unit</b>             |                 |           |                    |
| EMMT-ST-57, EMMB-ST-57-...<br>EMGA-60-P-G...-SST-57 | 60G             | 8197457   | EAMM-A-L48-60G-G2  |
| EMMT-ST-87, EMMB-ST-87-...<br>EMGA-80-P-G...-SST-87 | 80G             | 8197455   | EAMM-A-L48-80G-G2  |
| <b>With third-party gear unit</b>                   |                 |           |                    |
| Third-party gear unit                               | 40G             | 8063480   | EAMM-A-L48-40G     |
| Third-party gear unit                               | 50GA            | 8188639   | EAMM-A-L48-50GA-G2 |
| Third-party gear unit                               | 56GA            | 8063482   | EAMM-A-L48-56GA    |
| Third-party gear unit                               | 68GA            | 8063486   | EAMM-A-L48-68GA    |
| Third-party gear unit                               | 70GA            | 8188640   | EAMM-A-L48-70GA-G2 |
| Third-party gear unit                               | 72GA            | 8063487   | EAMM-A-L48-72GA    |
| Third-party gear unit                               | 75GA            | 8063484   | EAMM-A-L48-75GA    |
| Third-party gear unit                               | 80G             | 8197455   | EAMM-A-L48-80G-G2  |
| Third-party gear unit                               | 90GA            | 8063489   | EAMM-A-L48-90GA    |
| Third-party gear unit                               | 90GB            | 8063488   | EAMM-A-L48-90GB    |
| Third-party gear unit                               | 120GA           | 8063490   | EAMM-A-L48-120GA   |

1) The input torque must not exceed the max. permissible transferable torque of the axial kit.

## Product range overview

### Permissible axis/motor combinations with toothed belt axis ELGD-TB-...

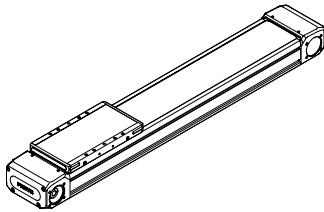

Table of interfaces for third-party motors

→ from page 64

Technical data for axial kits

→ from page 69

| Motor/gear unit <sup>1)</sup>                        | Motor interface | Axial kit |                    |
|--|-----------------|-----------|--------------------|
|  |                 | Part no.  | Type               |
| <b>ELGD-TB-...-WD-100</b>                            |                 |           |                    |
| <b>With servo motor</b>                              |                 |           |                    |
| Third-party motor                                    | 55A             | 3683331   | EAMM-A-L38-55A     |
| Third-party motor                                    | 58AA            | 8063456   | EAMM-A-L38-58AA    |
| EMMT-AS-60-..., EMMB-AS-60-..., third-party motor    | 60P, 60PA       | 8197454   | EAMM-A-L38-60P-G2  |
| Third-party motor                                    | 60R             | 8197451   | EAMM-A-L38-60R-G2  |
| Third-party motor                                    | 60RB            | 8063460   | EAMM-A-L38-60RB    |
| Third-party motor                                    | 60RA            | 8197449   | EAMM-A-L38-60RA    |
| Third-party motor                                    | 70A             | 557979    | EAMM-A-L38-70A     |
| Third-party motor                                    | 70AA, 70AB      | 8063461   | EAMM-A-L38-70AA    |
| Third-party motor                                    | 84AA            | 8063464   | EAMM-A-L38-84AA    |
| Third-party motor                                    | 88A             | 8063463   | EAMM-A-L38-88A     |
| <b>With servo motor and gear unit</b>                |                 |           |                    |
| EMME-AS-40-...<br>EMGA-40-P-G...-EAS-40              | 40G             | 8197448   | EAMM-A-L38-40G-G2  |
| EMMT-AS-60-...<br>EMGA-60-P-G...-EAS-60              | 60H             | 8197452   | EAMM-A-L38-60H-G2  |
| <b>With servo motor and right-angle gear unit</b>    |                 |           |                    |
| EMMT-AS-60-..., EMMB-AS-60-...<br>EMGA-60-A-G...-60P | 60H             | 8197452   | EAMM-A-L38-60H-G2  |
| <b>With stepper motor</b>                            |                 |           |                    |
| EMMT-ST-57, EMMB-ST-57-...<br>Third-party motor      | 57A             | 8197461   | EAMM-A-L38-57A-G2  |
| Third-party motor                                    | 57AA            | 8063457   | EAMM-A-L38-57AA    |
| Third-party motor                                    | 60AA            | 8107702   | EAMM-A-L38-60AA    |
| EMMT-ST-87, EMMB-ST-87-...<br>Third-party motor      | 87A             | 8197447   | EAMM-A-L38-87A-G2  |
| <b>With stepper motor and gear unit</b>              |                 |           |                    |
| EMMT-ST-42, EMMB-ST-42-...<br>EMGA-40-P-G...-SST-42  | 40G             | 8197448   | EAMM-A-L38-40G-G2  |
| EMMT-ST-57, EMMB-ST-57-...<br>EMGA-60-P-G...-SST-57  | 60G             | 8197460   | EAMM-A-L38-60G-G2  |
| <b>With third-party gear unit</b>                    |                 |           |                    |
| Third-party gear unit                                | 40G             | 8197448   | EAMM-A-L38-40G-G2  |
| Third-party gear unit                                | 50GA            | 8063466   | EAMM-A-L38-50GA    |
| Third-party gear unit                                | 56GA            | 8063467   | EAMM-A-L38-56GA    |
| Third-party gear unit                                | 68GA            | 8063469   | EAMM-A-L38-68GA    |
| Third-party gear unit                                | 70GA            | 8199483   | EAMM-A-L38-70GA-G2 |
| Third-party gear unit                                | 72GA            | 8063470   | EAMM-A-L38-72GA    |

1) The input torque must not exceed the max. permissible transferable torque of the axial kit.

## Product range overview

## Permitted axis/motor combinations with ball screw axis ELGD-BS-...

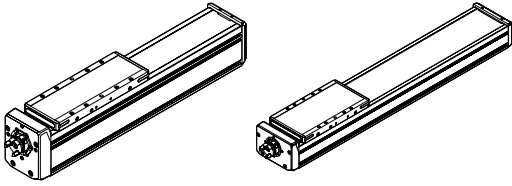

Table of interfaces for third-party motors

→ from page 64

Technical data for axial kits

→ from page 69

| Motor <sup>1)</sup><br>Type                       | Motor interface | Axial kit |                 |
|---|-----------------|-----------|-----------------|
|   |                 | Part no.  | Type            |
| <b>ELGD-BS-...-60/ ELGD-BS-...-WD-100</b>         |                 |           |                 |
| <b>With servo motor</b>                           |                 |           |                 |
| Third-party motor                                 | 55A             | 8082614   | EAMM-A-T42-55A  |
| Third-party motor                                 | 58AA            | 8094935   | EAMM-A-T42-58AA |
| EMMT-AS-60-..., EMMB-AS-60-..., third-party motor | 60P, 60PA       | ★ 4133487 | EAMM-A-T42-60P  |
| Third-party motor                                 | 60R             | 8093289   | EAMM-A-T42-60R  |
| Third-party motor                                 | 60RA            | 8092264   | EAMM-A-T42-60RA |
| EMMT-AS-80-..., EMMB-AS-80-..., third-party motor | 80P             | ★ 4623788 | EAMM-A-T42-80P  |
| <b>With stepper motor</b>                         |                 |           |                 |
| EMMT-ST-57, EMMB-ST-57-...                        | 57A             | ★ 4327034 | EAMM-A-T42-57A  |
| Third-party motor                                 | 60AA            | 8092255   | EAMM-A-T42-60AA |
| Third-party motor                                 | 60AB            | 8094949   | EAMM-A-T42-60AB |
| EMMT-ST-87, EMMB-ST-87-...                        | 87A             | ★ 4610008 | EAMM-A-T42-87A  |

1) The input torque must not exceed the max. permissible transferable torque of the axial kit.

| Motor <sup>1)</sup><br>Type                       | Motor interface | Axial kit |                 |
|---|-----------------|-----------|-----------------|
|   |                 | Part no.  | Type            |
| <b>ELGD-BS-...-80</b>                             |                 |           |                 |
| <b>With servo motor</b>                           |                 |           |                 |
| EMMT-AS-60-..., EMMB-AS-60-..., third-party motor | 60P, 60PA       | ★ 4824833 | EAMM-A-T46-60P  |
| Third-party motor                                 | 60R             | 8126174   | EAMM-A-T46-60R  |
| Third-party motor                                 | 60RA            | 8126175   | EAMM-A-T46-60RA |
| Third-party motor                                 | 70A             | 8092674   | EAMM-A-T46-70A  |
| Third-party motor                                 | 70AA, 70AB      | 8096057   | EAMM-A-T46-70AA |
| EMMT-AS-80-..., EMMB-AS-80-..., third-party motor | 80P             | ★ 4624170 | EAMM-A-T46-80P  |
| Third-party motor                                 | 80PA, 80RA      | 8091047   | EAMM-A-T46-80PA |
| Third-party motor                                 | 80PB, 80R       | 8096175   | EAMM-A-T46-80PB |
| EMMT-AS-100-..., third-party motor                | 100A            | ★ 4624227 | EAMM-A-T46-100A |
| <b>With stepper motor</b>                         |                 |           |                 |
| Third-party motor                                 | 85AA            | 8096186   | EAMM-A-T46-85AA |
| EMMT-ST-57, EMMB-ST-57-...                        | 57A             | 8169409   | EAMM-A-T46-57A  |
| EMMT-ST-87, EMMB-ST-87-...                        | 87A             | ★ 4048771 | EAMM-A-T46-87A  |

1) The input torque must not exceed the max. permissible transferable torque of the axial kit.

## Product range overview

### Permissible axis/motor combinations with toothed belt axis ELGA-TB-...

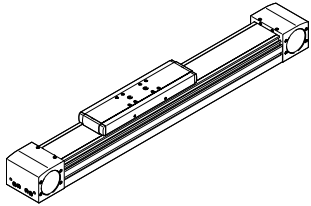

Table of interfaces for third-party motors

→ from page 64

Technical data for axial kits

→ from page 69

| Motor/gear unit <sup>1)</sup><br>Type                        | Motor interface | Axial kit        |                          |
|--|-----------------|------------------|--------------------------|
|  |                 | Part no.         | Type                     |
| <b>ELGA-TB-...-70</b>  |                 |                  |                          |
| <b>With servo motor</b>                                      |                 |                  |                          |
| <b>EMMT-AS-60-..., EMMB-AS-60-..., third-party motor</b>     | 60P, 60PA       | <b>8188590</b>   | <b>EAMM-A-N38-60P</b>    |
| <b>Third-party gear unit</b>                                 | 60RA            | <b>8063575</b>   | <b>EAMM-A-N38-60RA</b>   |
| <b>Third-party motor</b>                                     | 70A             | <b>1202331</b>   | <b>EAMM-A-N38-70A</b>    |
| <b>Third-party motor</b>                                     | 70AA, 70AB      | <b>8063576</b>   | <b>EAMM-A-N38-70AA</b>   |
| <b>Third-party motor</b>                                     | 88A             | <b>8063579</b>   | <b>EAMM-A-N38-88A</b>    |
| <b>Third-party motor</b>                                     | 90R             | <b>8063580</b>   | <b>EAMM-A-N38-90R</b>    |
| <b>Third-party motor</b>                                     | 92RA            | <b>8063581</b>   | <b>EAMM-A-N38-92RA</b>   |
| <b>With servo motor and gear unit</b>                        |                 |                  |                          |
| <b>EMME-AS-40-...<br/>EMGA-40-P-G...-EAS-40</b>              | 40G             | <b>8063583</b>   | <b>EAMM-A-N38-40G</b>    |
| <b>EMMT-AS-60-...<br/>EMGA-60-P-G...-EAS-60</b>              | 60H             | <b>8197463</b>   | <b>EAMM-A-N38-60H-G2</b> |
| <b>With servo motor and right-angle gear unit</b>            |                 |                  |                          |
| <b>EMME-AS-40-..., EMMB-AS-40-...<br/>EMGA-40-A-G...-40P</b> | 40G             | <b>8063583</b>   | <b>EAMM-A-N38-40G</b>    |
| <b>EMMT-AS-60-..., EMMB-AS-60-...<br/>EMGA-60-A-G...-60P</b> | 60H             | <b>8197463</b>   | <b>EAMM-A-N38-60H-G2</b> |
| <b>With stepper motor</b>                                    |                 |                  |                          |
| <b>EMMT-ST-87, EMMB-ST-87-...</b>                            | 87A             | ★ <b>3324111</b> | <b>EAMM-A-N38-87A</b>    |
| <b>With stepper motor and gear unit</b>                      |                 |                  |                          |
| <b>EMMT-ST-57, EMMB-ST-57-...<br/>EMGA-60-P-G...-SST-57</b>  | 60G             | <b>8197462</b>   | <b>EAMM-A-N38-60G-G2</b> |
| <b>With third-party gear unit</b>                            |                 |                  |                          |
| <b>Third-party gear unit</b>                                 | 40G             | <b>8063583</b>   | <b>EAMM-A-N38-40G</b>    |
| <b>Third-party gear unit</b>                                 | 50GA            | <b>8063584</b>   | <b>EAMM-A-N38-50GA</b>   |
| <b>Third-party gear unit</b>                                 | 56GA            | <b>8063585</b>   | <b>EAMM-A-N38-56GA</b>   |
| <b>Third-party gear unit</b>                                 | 60H             | <b>8197463</b>   | <b>EAMM-A-N38-60H-G2</b> |
| <b>Third-party gear unit</b>                                 | 68GA            | <b>8063587</b>   | <b>EAMM-A-N38-68GA</b>   |
| <b>Third-party gear unit</b>                                 | 70GA            | <b>8063586</b>   | <b>EAMM-A-N38-70GA</b>   |
| <b>Third-party gear unit</b>                                 | 72GA            | <b>8063588</b>   | <b>EAMM-A-N38-72GA</b>   |

1) The input torque must not exceed the max. permissible transferable torque of the axial kit.

## Product range overview

## Permissible axis/motor combinations with toothed belt axis ELGA-TB-...

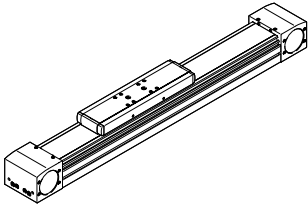

Table of interfaces for third-party motors

→ from page 64

Technical data for axial kits

→ from page 69

| Motor/gear unit <sup>1)</sup><br>Type                        | Motor interface | Axial kit      |                           |
|--|-----------------|----------------|---------------------------|
|  |                 | Part no.       | Type                      |
| <b>ELGA-TB-...-80</b>  |                 |                |                           |
| <b>With servo motor</b>                                      |                 |                |                           |
| <b>EMMT-AS-60-..., EMMB-AS-60-..., third-party motor</b>     | 60P, 60PA       | <b>8197468</b> | <b>EAMM-A-N48-60P</b>     |
| <b>Third-party motor</b>                                     | 70AA            | <b>8063591</b> | <b>EAMM-A-N48-70AA</b>    |
| <b>EMMT-AS-80-..., EMMB-AS-80-..., third-party motor</b>     | 80P             | <b>8063592</b> | <b>EAMM-A-N48-80P</b>     |
| <b>Third-party motor</b>                                     | 80PB            | <b>8107714</b> | <b>EAMM-A-N48-80PB</b>    |
| <b>Third-party motor</b>                                     | 84AA            | <b>8063594</b> | <b>EAMM-A-N48-84AA</b>    |
| <b>Third-party motor</b>                                     | 88A             | <b>8063593</b> | <b>EAMM-A-N48-88A</b>     |
| <b>EMMT-AS-100-..., third-party motor</b>                    | 100A            | <b>8197464</b> | <b>EAMM-A-N48-100A-G2</b> |
| <b>With servo motor and gear unit</b>                        |                 |                |                           |
| <b>EMME-AS-40-...<br/>EMGA-40-P-G...-EAS-40</b>              | 40G             | <b>8197467</b> | <b>EAMM-A-N48-40G</b>     |
| <b>EMMT-AS-60-...<br/>EMGA-60-P-G...-EAS-60</b>              | 60H             | <b>8197465</b> | <b>EAMM-A-N48-60H-G2</b>  |
| <b>EMMT-AS-80-...<br/>EMGA-80-P-G...-EAS-80</b>              | 80G             | <b>8197470</b> | <b>EAMM-A-N48-80G-G2</b>  |
| <b>EMMT-AS-100-...<br/>EMGA-80-P-G...-SAS-100</b>            | 80G             | <b>8197470</b> | <b>EAMM-A-N48-80G-G2</b>  |
| <b>With servo motor and right-angle gear unit</b>            |                 |                |                           |
| <b>EMMT-AS-60-..., EMMB-AS-60-...<br/>EMGA-60-A-G...-60P</b> | 60H             | <b>8197465</b> | <b>EAMM-A-N48-60H-G2</b>  |
| <b>EMMT-AS-80-..., EMMB-AS-80-...<br/>EMGA-80-A-G...-80P</b> | 80G             | <b>8197470</b> | <b>EAMM-A-N48-80G-G2</b>  |
| <b>EMMT-AS-100-...<br/>EMGA-80-A-G...-100A</b>               | 80G             | <b>8197470</b> | <b>EAMM-A-N48-80G-G2</b>  |
| <b>With stepper motor</b>                                    |                 |                |                           |
| <b>EMMT-ST-87, EMMB-ST-87-...</b>                            | 87A             | <b>8197466</b> | <b>EAMM-A-N48-87A</b>     |

1) The input torque must not exceed the max. permissible transferable torque of the axial kit.

## Product range overview

### Permissible axis/motor combinations with toothed belt axis ELGA-TB-...

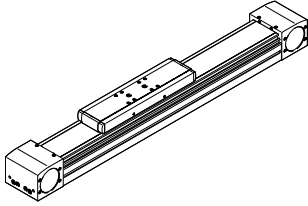

Table of interfaces for third-party motors

→ from page 64

Technical data for axial kits

→ from page 69

| Motor/gear unit <sup>1)</sup><br>Type               | Motor interface | Axial kit |                    |
|---|-----------------|-----------|--------------------|
|   |                 | Part no.  | Type               |
| <b>ELGA-TB-...-80</b>                               |                 |           |                    |
| <b>With stepper motor and gear unit</b>             |                 |           |                    |
| EMMT-ST-57, EMMB-ST-57-...<br>EMGA-60-P-G...-SST-57 | 60G             | 8197469   | EAMM-A-N48-60G-G2  |
| EMMT-ST-87, EMMB-ST-87-...<br>EMGA-80-P-G...-SST-87 | 80G             | 8197470   | EAMM-A-N48-80G-G2  |
| <b>With third-party gear unit</b>                   |                 |           |                    |
| Third-party gear unit                               | 50GA            | 8063595   | EAMM-A-N48-50GA    |
| Third-party gear unit                               | 56GA            | 8063596   | EAMM-A-N48-56GA    |
| Third-party gear unit                               | 60H             | 8197465   | EAMM-A-N48-60H-G2  |
| Third-party gear unit                               | 68GA            | 8063600   | EAMM-A-N48-68GA    |
| Third-party gear unit                               | 70GA            | 8199479   | EAMM-A-N48-70GA-G2 |
| Third-party gear unit                               | 72GA            | 8063601   | EAMM-A-N48-72GA    |
| Third-party gear unit                               | 75GA            | 8063598   | EAMM-A-N48-75GA    |
| Third-party gear unit                               | 80G             | 8197470   | EAMM-A-N48-80G-G2  |
| Third-party gear unit                               | 90GA            | 8063603   | EAMM-A-N48-90GA    |
| Third-party gear unit                               | 90GB            | 8063602   | EAMM-A-N48-90GB    |
| Third-party gear unit                               | 120GA           | 8063605   | EAMM-A-N48-120GA   |

1) The input torque must not exceed the max. permissible transferable torque of the axial kit.

## Product range overview

## Permissible axis/motor combinations with toothed belt axis ELGA-TB-...

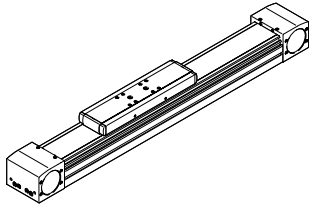

Table of interfaces for third-party motors

→ from page 64

Technical data for axial kits

→ from page 69

| Motor/gear unit <sup>1)</sup><br>Type                | Motor interface | Axial kit |                   |
|--|-----------------|-----------|-------------------|
|  |                 | Part no.  | Type              |
| <b>ELGA-TB-...-120</b>                               |                 |           |                   |
| <b>With servo motor</b>                              |                 |           |                   |
| Third-party motor                                    | 84AA            | 8063606   | EAMM-A-N80-84AA   |
| Third-party motor                                    | 100A            | 8063607   | EAMM-A-N80-100A   |
| EMMT-AS-150-...                                      | 150A            | 8157277   | EAMM-A-N80-150A   |
| <b>With servo motor and gear unit</b>                |                 |           |                   |
| EMMT-AS-80-...<br>EMGA-80-P-G...-EAS-80              | 80G             | 8197471   | EAMM-A-N80-80G-G2 |
| EMMT-AS-100-...<br>EMGA-80-P-G...-SAS-100            | 80G             | 8197471   | EAMM-A-N80-80G-G2 |
| EMMT-AS-100-...<br>EMGA-120-P-G...-SAS-100           | 120G            | ★ 1201695 | EAMM-A-N80-120G   |
| EMMT-AS-150-...<br>EMGA-120-P-G...-SAS-140           | 120G            | ★ 1201695 | EAMM-A-N80-120G   |
| <b>With servo motor and right-angle gear unit</b>    |                 |           |                   |
| EMMT-AS-80-..., EMMB-AS-80-...<br>EMGA-80-A-G...-80P | 80G             | 8197471   | EAMM-A-N80-80G-G2 |
| EMMT-AS-100-...<br>EMGA-80-A-G...-100A               | 80G             | 8197471   | EAMM-A-N80-80G-G2 |
| <b>With stepper motor and gear unit</b>              |                 |           |                   |
| EMMT-ST-87, EMMB-ST-87-...<br>EMGA-80-P-G...-SST-87  | 80G             | 8197471   | EAMM-A-N80-80G-G2 |
| <b>With third-party gear unit</b>                    |                 |           |                   |
| Third-party gear unit                                | 68GA            | 8063611   | EAMM-A-N80-68GA   |
| Third-party gear unit                                | 70GA            | 8063608   | EAMM-A-N80-70GA   |
| Third-party gear unit                                | 72GA            | 8063612   | EAMM-A-N80-72GA   |
| Third-party gear unit                                | 75GA            | 8063609   | EAMM-A-N80-75GA   |
| Third-party gear unit                                | 80G             | 8197471   | EAMM-A-N80-80G-G2 |
| Third-party gear unit                                | 90GA            | 8063614   | EAMM-A-N80-90GA   |
| Third-party gear unit                                | 90GB            | 8063613   | EAMM-A-N80-90GB   |
| Third-party gear unit                                | 115GA           | 8063615   | EAMM-A-N80-115GA  |
| Third-party gear unit                                | 120GA           | 8063617   | EAMM-A-N80-120GA  |
| Third-party gear unit                                | 120GB           | 8063618   | EAMM-A-N80-120GB  |
| Third-party gear unit                                | 120GC           | 8063619   | EAMM-A-N80-120GC  |

1) The input torque must not exceed the max. permissible transferable torque of the axial kit.

## Product range overview

### Permissible axis/motor combinations with toothed belt axis ELGA-TB-...

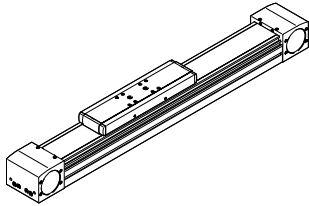

Table of interfaces for third-party motors

→ from page 64

Technical data for axial kits

→ from page 69

| Motor/gear unit <sup>1)</sup>                        | Motor interface | Axial kit |                    |
|--|-----------------|-----------|--------------------|
|  |                 | Part no.  | Type               |
| <b>ELGA-TB-...-150</b>                               |                 |           |                    |
| <b>With servo motor</b>                              |                 |           |                    |
| EMMT-AS-150-...                                      | 150A            | 8157280   | EAMM-A-L95-150A-G2 |
| EMMT-AS-190-...                                      | 190B            | 8157282   | EAMM-A-L95-190B-G2 |
| <b>With servo motor and gear unit</b>                |                 |           |                    |
| EMMT-AS-80-...<br>EMGA-80-P-G...-EAS-80              | 80G             | 3660191   | EAMM-A-L95-80G-G2  |
| EMMT-AS-100-...<br>EMGA-80-P-G...-SAS-100            | 80G             | 3660191   | EAMM-A-L95-80G-G2  |
| EMMT-AS-100-...<br>EMGA-120-P-G...-SAS-100           | 120G            | ★ 3659941 | EAMM-A-L95-120G-G2 |
| EMMT-AS-150-...<br>EMGA-120-P-G...-SAS-140           | 120G            | ★ 3659941 | EAMM-A-L95-120G-G2 |
| <b>With servo motor and right-angle gear unit</b>    |                 |           |                    |
| EMMT-AS-80-..., EMMB-AS-80-...<br>EMGA-80-A-G...-80P | 80G             | 3660191   | EAMM-A-L95-80G-G2  |
| EMMT-AS-100-...<br>EMGA-80-A-G...-100A               | 80G             | 3660191   | EAMM-A-L95-80G-G2  |
| <b>With third-party gear unit</b>                    |                 |           |                    |
| Third-party gear unit                                | 68GA            | 8063524   | EAMM-A-L95-68GA    |
| Third-party gear unit                                | 72GA            | 8063525   | EAMM-A-L95-72GA    |
| Third-party gear unit                                | 75GA            | 8063522   | EAMM-A-L95-75GA    |
| Third-party gear unit                                | 80G             | 3660191   | EAMM-A-L95-80G-G2  |
| Third-party gear unit                                | 90GA            | 8063526   | EAMM-A-L95-90GA    |
| Third-party gear unit                                | 115GA           | 8063527   | EAMM-A-L95-115GA   |
| Third-party gear unit                                | 120G            | ★ 3659941 | EAMM-A-L95-120G-G2 |
| Third-party gear unit                                | 120GA           | 8063529   | EAMM-A-L95-120GA   |
| Third-party gear unit                                | 120GB           | 8063530   | EAMM-A-L95-120GB   |
| Third-party gear unit                                | 120GC           | 8063531   | EAMM-A-L95-120GC   |
| Third-party gear unit                                | 160G            | 8197453   | EAMM-A-L95-160G-G2 |

1) The input torque must not exceed the max. permissible transferable torque of the axial kit.



## Product range overview

## Permitted axis/motor combinations with ball screw axis ELGA-BS-...

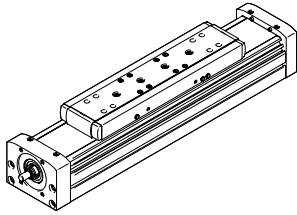

Table of interfaces for third-party motors

→ from page 64

Technical data for axial kits

→ from page 69

| Motor/gear unit <sup>1)</sup><br>Type                | Motor interface | Axial kit |                    |
|--|-----------------|-----------|--------------------|
|  |                 | Part no.  | Type               |
| <b>ELGA-BS-...-70</b>                                |                 |           |                    |
| <b>With servo motor</b>                              |                 |           |                    |
| EMME-AS-40-..., EMMB-AS-40-...                       | 40P             | ★ 3637972 | EAMM-A-S38-40P-G2  |
| Third-party motor                                    | 40A             | 3637971   | EAMM-A-S38-40A-G2  |
| Third-party motor                                    | 55A             | 8197483   | EAMM-A-S38-55A-G3  |
| Third-party motor                                    | 58AA            | 8105927   | EAMM-A-S38-58AA    |
| EMMT-AS-60-..., EMMB-AS-60-..., third-party motor    | 60P             | 8197479   | EAMM-A-S38-60P-G3  |
| Third-party motor                                    | 60R             | 8197475   | EAMM-A-S38-60R-G2  |
| Third-party motor                                    | 60RA            | 8197484   | EAMM-A-S38-60RA-G2 |
| <b>With servo motor and gear unit</b>                |                 |           |                    |
| EMME-AS-40-...<br>EMGA-40-P-G...-EAS-40              | 40G             | 1456647   | EAMM-A-S38-40G-G2  |
| <b>With servo motor and right-angle gear unit</b>    |                 |           |                    |
| EMME-AS-40-..., EMMB-AS-40-...<br>EMGA-40-A-G...-40P | 40G             | 1456647   | EAMM-A-S38-40G-G2  |
| <b>With stepper motor</b>                            |                 |           |                    |
| EMMT-ST-42, EMMB-ST-42-..., third-party motor        | 42A             | ★ 3637965 | EAMM-A-S38-42A-G2  |
| EMMT-ST-57, EMMB-ST-57-...                           | 57A             | ★ 3637956 | EAMM-A-S38-57A-G2  |
| Third-party motor                                    | 60AA            | 8105926   | EAMM-A-S38-60AA    |
| <b>With stepper motor and gear unit</b>              |                 |           |                    |
| EMMT-ST-42, EMMB-ST-42-...<br>EMGA-40-P-G...-SST-42  | 40G             | 1456647   | EAMM-A-S38-40G-G2  |
| <b>With third-party gear unit</b>                    |                 |           |                    |
| Third-party gear unit                                | 40G             | 1456647   | EAMM-A-S38-40G-G2  |
| Third-party gear unit                                | 50GA            | 8105922   | EAMM-A-S38-50GA    |

1) The input torque must not exceed the max. permissible transferable torque of the axial kit.

## Product range overview

### Permitted axis/motor combinations with ball screw axis ELGA-BS-...

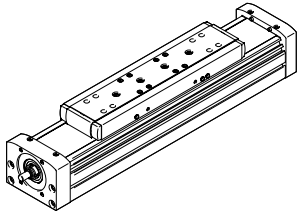

Table of interfaces for third-party motors

→ from page 64

Technical data for axial kits

→ from page 69

| Motor/gear unit <sup>1)</sup>                        | Motor interface | Axial kit |                    |
|--|-----------------|-----------|--------------------|
|  |                 | Part no.  | Type               |
| <b>ELGA-BS-...-80</b>                                |                 |           |                    |
| <b>With servo motor</b>                              |                 |           |                    |
| Third-party motor                                    | 55A             | 3637961   | EAMM-A-S48-55A-G2  |
| Third-party motor                                    | 58AA            | 8105933   | EAMM-A-S48-58AA    |
| EMMT-AS-60-..., EMMB-AS-60-..., third-party motor    | 60P             | 8197481   | EAMM-A-S48-60P-G3  |
| Third-party motor                                    | 60R             | 8197485   | EAMM-A-S48-60R-G2  |
| Third-party motor                                    | 60RA            | 8197474   | EAMM-A-S48-60RA-G2 |
| Third-party motor                                    | 70A             | 3637957   | EAMM-A-S48-70A-G2  |
| Third-party motor                                    | 70AA, 70AB      | 8105942   | EAMM-A-S48-70AA    |
| EMMT-AS-80-..., EMMB-AS-80-..., third-party motor    | 80P, 80PA, 80RA | 8197480   | EAMM-A-S48-80P     |
| Third-party motor                                    | 80PB, 80R       | 8197487   | EAMM-A-S48-80PB    |
| <b>With servo motor and gear unit</b>                |                 |           |                    |
| EMME-AS-40-...<br>EMGA-40-P-G...-EAS-40              | 40G             | 1456650   | EAMM-A-S48-40G-G2  |
| EMMT-AS-60-...<br>EMGA-60-P-G...-EAS-60              | 60H             | 8197482   | EAMM-A-S48-60H-G3  |
| <b>With servo motor and right-angle gear unit</b>    |                 |           |                    |
| EMME-AS-40-..., EMMB-AS-40-...<br>EMGA-40-A-G...-40P | 40G             | 1456650   | EAMM-A-S48-40G-G2  |
| EMMT-AS-60-..., EMMB-AS-60-...<br>EMGA-60-A-G...-60P | 60H             | 8197482   | EAMM-A-S48-60H-G3  |
| <b>With stepper motor</b>                            |                 |           |                    |
| EMMT-ST-57, EMMB-ST-57-...<br>Third-party motor      | 57A             | ★ 3637963 | EAMM-A-S48-57A-G2  |
| Third-party motor                                    | 60AA            | 8105935   | EAMM-A-S48-60AA    |
| EMMT-ST-87, EMMB-ST-87-...<br>Third-party motor      | 87A             | ★ 3637962 | EAMM-A-S48-87A-G2  |
| <b>With stepper motor and gear unit</b>              |                 |           |                    |
| EMMT-ST-42, EMMB-ST-42-...<br>EMGA-40-P-G...-SST-42  | 40G             | 1456650   | EAMM-A-S48-40G-G2  |
| EMMT-ST-57, EMMB-ST-57-...<br>EMGA-60-P-G...-SST-57  | 60G             | 8197477   | EAMM-A-S48-60G-G3  |
| <b>With third-party gear unit</b>                    |                 |           |                    |
| Third-party gear unit                                | 40G             | 1456650   | EAMM-A-S48-40G-G2  |
| Third-party gear unit                                | 50GA            | 8105930   | EAMM-A-S48-50GA    |
| Third-party gear unit                                | 60H             | 8197482   | EAMM-A-S48-60H-G3  |

1) The input torque must not exceed the max. permissible transferable torque of the axial kit.

## Product range overview

## Permitted axis/motor combinations with ball screw axis ELGA-BS-...

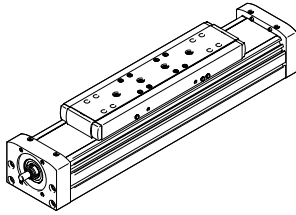

Table of interfaces for third-party motors

→ from page 64

Technical data for axial kits

→ from page 69

| Motor/gear unit <sup>1)</sup><br>Type                | Motor interface | Axial kit |                    |
|--|-----------------|-----------|--------------------|
|  |                 | Part no.  | Type               |
| <b>ELGA-BS-...-120</b>                               |                 |           |                    |
| <b>With servo motor</b>                              |                 |           |                    |
| Third-party motor                                    | 70A             | 3637959   | EAMM-A-S62-70A-G2  |
| EMMT-AS-80-..., EMMB-AS-80-..., third-party motor    | 80P             | ★ 3637970 | EAMM-A-S62-80P-G2  |
| Third-party motor                                    | 80PB, 80R       | 8110208   | EAMM-A-S62-80PB    |
| Third-party motor                                    | 82AA            | 8110211   | EAMM-A-S62-82AA    |
| Third-party motor                                    | 84AA            | 8110226   | EAMM-A-S62-84AA    |
| EMMT-AS-100-..., third-party motor                   | 100A            | 8197486   | EAMM-A-S62-100A-G3 |
| EMMT-AS-150-...                                      | 150A            | 8157272   | EAMM-A-S62-150A-G2 |
| <b>With servo motor and gear unit</b>                |                 |           |                    |
| EMMT-AS-60-...<br>EMGA-60-P-G...-EAS-60              | 60H             | 1456654   | EAMM-A-S62-60H-G2  |
| EMMT-AS-80-...<br>EMGA-80-P-G...-EAS-80              | 80G             | 8197473   | EAMM-A-S62-80G-G3  |
| EMMT-AS-100-...<br>EMGA-80-P-G...-SAS-100            | 80G             | 8197473   | EAMM-A-S62-80G-G3  |
| <b>With servo motor and right-angle gear unit</b>    |                 |           |                    |
| EMMT-AS-60-..., EMMB-AS-60-...<br>EMGA-60-A-G...-60P | 60H             | 1456654   | EAMM-A-S62-60H-G2  |
| EMMT-AS-80-..., EMMB-AS-80-...<br>EMGA-80-A-G...-80P | 80G             | 8197473   | EAMM-A-S62-80G-G3  |
| EMMT-AS-100-...<br>EMGA-80-A-G...-100A               | 80G             | 8197473   | EAMM-A-S62-80G-G3  |

1) The input torque must not exceed the max. permissible transferable torque of the axial kit.

## Product range overview

### Permitted axis/motor combinations with ball screw axis ELGA-BS-...

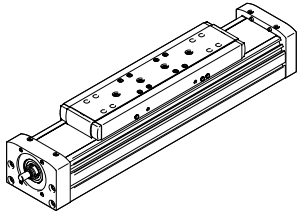

Table of interfaces for third-party motors

→ from page 64

Technical data for axial kits

→ from page 69

| Motor/gear unit <sup>1)</sup><br>Type               | Motor interface | Axial kit |                    |
|---|-----------------|-----------|--------------------|
|   |                 | Part no.  | Type               |
| <b>ELGA-BS-...-120</b>                              |                 |           |                    |
| <b>With stepper motor</b>                           |                 |           |                    |
| EMMT-ST-87, EMMB-ST-87-...                          | 87A             | ★ 3637966 | EAMM-A-S62-87A-G2  |
| <b>With stepper motor and gear unit</b>             |                 |           |                    |
| EMMT-ST-57, EMMB-ST-57-...<br>EMGA-60-P-G...-SST-57 | 60G             | 2297649   | EAMM-A-S62-60G-G2  |
| EMMT-ST-87, EMMB-ST-87-...<br>EMGA-80-P-G...-SST-87 | 80G             | 8197473   | EAMM-A-S62-80G-G3  |
| <b>With third-party gear unit</b>                   |                 |           |                    |
| Third-party gear unit                               | 60H             | 1456654   | EAMM-A-S62-60H-G2  |
| Third-party gear unit                               | 70GA            | 8110082   | EAMM-A-S62-70GA    |
| Third-party gear unit                               | 80G             | 8197473   | EAMM-A-S62-80G-G3  |
| <b>ELGA-BS-...-150</b>                              |                 |           |                    |
| <b>With servo motor</b>                             |                 |           |                    |
| Third-party motor                                   | 84AA            | 8107720   | EAMM-A-S95-84AA    |
| EMMT-AS-100-..., third-party motor                  | 100A            | 3637955   | EAMM-A-S95-100A-G2 |
| EMMT-AS-150-...                                     | 150A            | 8157279   | EAMM-A-S95-150A-G2 |
| <b>With servo motor and gear unit</b>               |                 |           |                    |
| EMMT-AS-80-...<br>EMGA-80-P-G...-EAS-80             | 80G             | 8197478   | EAMM-A-S95-80G     |
| EMMT-AS-100-...<br>EMGA-80-P-G...-SAS-100           | 80G             | 8197478   | EAMM-A-S95-80G     |
| EMMT-AS-100-...<br>EMGA-120-P-G...-SAS-100          | 120G            | 8197476   | EAMM-A-S95-120G    |
| EMMT-AS-150-...<br>EMGA-120-P-G...-SAS-140          | 120G            | 8197476   | EAMM-A-S95-120G    |
| <b>With third-party gear unit</b>                   |                 |           |                    |
| Third-party gear unit                               | 90GA            | 8110066   | EAMM-A-S95-90GA    |

1) The input torque must not exceed the max. permissible transferable torque of the axial kit.

## Product range overview

## Permitted axis/motor combinations with ball screw axis ELGT-BS-...

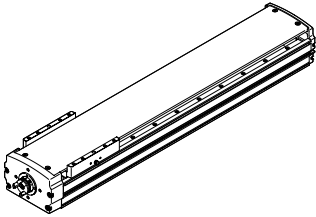

Table of interfaces for third-party motors

→ from page 64

Technical data for axial kits

→ from page 69

| Motor <sup>1)</sup><br>Type                              | Motor interface | Axial kit |                 |
|--|-----------------|-----------|-----------------|
|  |                 | Part no.  | Type            |
| <b>ELGT-BS-...-90/-120/-160</b>                          |                 |           |                 |
| <b>With servo motor</b>                                  |                 |           |                 |
| <b>EMMT-AS-60-..., EMMB-AS-60-..., third-party motor</b> | 60P, 60PA       | ★ 4824833 | EAMM-A-T46-60P  |
| Third-party motor  | 60R             | 8126174   | EAMM-A-T46-60R  |
| Third-party motor  | 60RA            | 8126174   | EAMM-A-T46-60RA |
| Third-party motor  | 70A             | 8092674   | EAMM-A-T46-70A  |
| Third-party motor  | 70AA, 70AB      | 8096057   | EAMM-A-T46-70AA |
| <b>EMMT-AS-80-..., EMMB-AS-80-..., third-party motor</b> | 80P             | ★ 4624170 | EAMM-A-T46-80P  |
| Third-party motor  | 80PA, 80RA      | 8091047   | EAMM-A-T46-80PA |
| Third-party motor  | 80PB, 80R       | 8096175   | EAMM-A-T46-80PB |
| <b>EMMT-AS-100-..., third-party motor</b>                | 100A            | ★ 4624227 | EAMM-A-T46-100A |
| <b>With stepper motor</b>                                |                 |           |                 |
| Third-party motor  | 85AA            | 8096186   | EAMM-A-T46-85AA |
| <b>EMMT-ST-57, EMMB-ST-57-...</b>                        | 57A             | 8169409   | EAMM-A-T46-57A  |
| <b>EMMT-ST-87, EMMB-ST-87-...</b>                        | 87A             | ★ 4048771 | EAMM-A-T46-87A  |

1) The input torque must not exceed the max. permissible transferable torque of the axial kit.

## Product range overview

### Permissible axis/motor combinations with toothed belt axis ELGC-TB-...

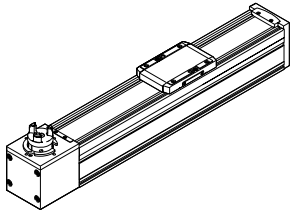

Table of interfaces for third-party motors

→ from page 64

Technical data for axial kits

→ from page 69

| Motor <sup>1)</sup><br>Type                       | Motor interface | Axial kit |                 |
|---|-----------------|-----------|-----------------|
|   |                 | Part no.  | Type            |
| <b>ELGC-TB-...-45</b>                             |                 |           |                 |
| <b>With servo motor</b>                           |                 |           |                 |
| Third-party motor                                 | 38AA            | 8093023   | EAMM-A-V32-38AA |
| EMME-AS-40-..., EMMB-AS-40-...                    | 40P             | ★ 4595742 | EAMM-A-V32-40P  |
| Third-party motor                                 | 40R             | 8087090   | EAMM-A-V32-40R  |
| Third-party motor                                 | 40RA            | 8094180   | EAMM-A-V32-40RA |
| Third-party motor                                 | 58AA            | 8098982   | EAMM-A-V32-58AA |
| EMMT-AS-60-..., EMMB-AS-60-..., third-party motor | 60P             | ★ 4608750 | EAMM-A-V32-60P  |
| Third-party motor                                 | 60PA            | 8091053   | EAMM-A-V32-60PA |
| Third-party motor                                 | 60RA            | 8093041   | EAMM-A-V32-60RA |
| <b>With stepper motor</b>                         |                 |           |                 |
| EMMT-ST-42, EMMB-ST-42-..., third-party motor     | 42A             | ★ 4281142 | EAMM-A-V32-42A  |
| Third-party motor                                 | 42AB            | 8094200   | EAMM-A-V32-42AB |
| EMMT-ST-57, EMMB-ST-57-...                        | 57A             | ★ 4597016 | EAMM-A-V32-57A  |
| Third-party motor                                 | 60AA            | 8092271   | EAMM-A-V32-60AA |
| <b>ELGC-TB-...-60</b>                             |                 |           |                 |
| <b>With servo motor</b>                           |                 |           |                 |
| Third-party motor                                 | 55A             | 8082614   | EAMM-A-T42-55A  |
| Third-party motor                                 | 58AA            | 8094935   | EAMM-A-T42-58AA |
| EMMT-AS-60-..., EMMB-AS-60-..., third-party motor | 60P, 60PA       | ★ 4133487 | EAMM-A-T42-60P  |
| Third-party motor                                 | 60R             | 8093289   | EAMM-A-T42-60R  |
| Third-party motor                                 | 60RA            | 8092264   | EAMM-A-T42-60RA |
| EMMT-AS-80-..., EMMB-AS-80-...                    | 80P             | ★ 4623788 | EAMM-A-T42-80P  |
| <b>With stepper motor</b>                         |                 |           |                 |
| EMMT-ST-57, EMMB-ST-57-...                        | 57A             | ★ 4327034 | EAMM-A-T42-57A  |
| Third-party motor                                 | 60AA            | 8092255   | EAMM-A-T42-60AA |
| Third-party motor                                 | 60AB            | 8094949   | EAMM-A-T42-60AB |
| EMMT-ST-87, EMMB-ST-87-...                        | 87A             | ★ 4610008 | EAMM-A-T42-87A  |

1) The input torque must not exceed the max. permissible transferable torque of the axial kit.

## Product range overview

## Permissible axis/motor combinations with toothed belt axis ELGC-TB-...

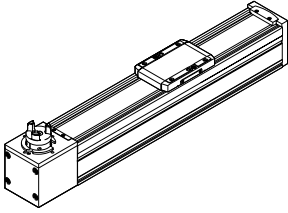

Table of interfaces for third-party motors

→ from page 64

Technical data for axial kits

→ from page 69

| Motor <sup>1)</sup><br>Type                              | Motor interface | Axial kit |                 |
|--|-----------------|-----------|-----------------|
|  |                 | Part no.  | Type            |
| <b>ELGC-TB-...-80</b>                                    |                 |           |                 |
| <b>With servo motor</b>                                  |                 |           |                 |
| <b>EMMT-AS-60-..., EMMB-AS-60-..., third-party motor</b> | 60P, 60PA       | ★ 4824833 | EAMM-A-T46-60P  |
| Third-party motor  | 60R             | 8126174   | EAMM-A-T46-60R  |
| Third-party motor  | 60RA            | 8126174   | EAMM-A-T46-60RA |
| Third-party motor  | 70A             | 8092674   | EAMM-A-T46-70A  |
| Third-party motor  | 70AA, 70AB      | 8096057   | EAMM-A-T46-70AA |
| <b>EMMT-AS-80-..., EMMB-AS-80-..., third-party motor</b> | 80P             | ★ 4624170 | EAMM-A-T46-80P  |
| Third-party motor  | 80PA, 80RA      | 8091047   | EAMM-A-T46-80PA |
| Third-party motor  | 80PB, 80R       | 8096175   | EAMM-A-T46-80PB |
| <b>EMMT-AS-100-..., third-party motor</b>                | 100A            | ★ 4624227 | EAMM-A-T46-100A |
| <b>With stepper motor</b>                                |                 |           |                 |
| Third-party motor  | 85AA            | 8096186   | EAMM-A-T46-85AA |
| <b>EMMT-ST-57, EMMB-ST-57-...</b>                        | 57A             | 8169409   | EAMM-A-T46-57A  |
| <b>EMMT-ST-87, EMMB-ST-87-...</b>                        | 87A             | ★ 4048771 | EAMM-A-T46-87A  |

1) The input torque must not exceed the max. permissible transferable torque of the axial kit.

## Product range overview

### Permitted axis/motor combinations with ball screw axis ELGC-BS-...

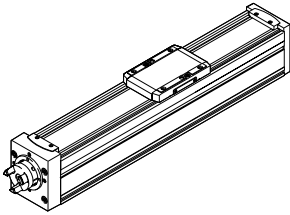

Table of interfaces for third-party motors

→ from page 64

Technical data for axial kits

→ from page 69

| Motor <sup>1)</sup><br>Type                       | Motor interface | Axial kit |                 |
|---|-----------------|-----------|-----------------|
|   |                 | Part no.  | Type            |
| <b>ELGC-BS-...-32</b>                             |                 |           |                 |
| <b>With servo motor</b>                           |                 |           |                 |
| Third-party motor                                 | 38AA            | 8093162   | EAMM-A-V25-38AA |
| EMME-AS-40-..., EMMB-AS-40-..., third-party motor | 40P             | ★ 4491059 | EAMM-A-V25-40P  |
| Third-party motor                                 | 40R             | 8087062   | EAMM-A-V25-40R  |
| Third-party motor                                 | 40RA            | 8094100   | EAMM-A-V25-40RA |
| <b>With stepper motor</b>                         |                 |           |                 |
| Third-party motor                                 | 35A             | 8093255   | EAMM-A-V25-35A  |
| EMMT-ST-42, EMMB-ST-42-..., third-party motor     | 42A             | ★ 4582608 | EAMM-A-V25-42A  |
| Third-party motor                                 | 42AB            | 8094108   | EAMM-A-V25-42AB |
| <b>ELGC-BS-...-45</b>                             |                 |           |                 |
| <b>With servo motor</b>                           |                 |           |                 |
| Third-party motor                                 | 38AA            | 8093023   | EAMM-A-V32-38AA |
| EMME-AS-40-..., EMMB-AS-40-...                    | 40P             | ★ 4595742 | EAMM-A-V32-40P  |
| Third-party motor                                 | 40R             | 8087090   | EAMM-A-V32-40R  |
| Third-party motor                                 | 40RA            | 8094180   | EAMM-A-V32-40RA |
| Third-party motor                                 | 58AA            | 8098982   | EAMM-A-V32-58AA |
| EMMT-AS-60-..., EMMB-AS-60-..., third-party motor | 60P             | ★ 4608750 | EAMM-A-V32-60P  |
| Third-party motor                                 | 60PA            | 8091053   | EAMM-A-V32-60PA |
| Third-party motor                                 | 60RA            | 8093041   | EAMM-A-V32-60RA |
| <b>With stepper motor</b>                         |                 |           |                 |
| EMMT-ST-42, EMMB-ST-42-..., third-party motor     | 42A             | ★ 4281142 | EAMM-A-V32-42A  |
| Third-party motor                                 | 42AB            | 8094200   | EAMM-A-V32-42AB |
| EMMT-ST-57, EMMB-ST-57-...                        | 57A             | ★ 4597016 | EAMM-A-V32-57A  |
| Third-party motor                                 | 60AA            | 8092271   | EAMM-A-V32-60AA |
| <b>ELGC-BS-...-60</b>                             |                 |           |                 |
| <b>With servo motor</b>                           |                 |           |                 |
| Third-party motor                                 | 55A             | 8082614   | EAMM-A-T42-55A  |
| Third-party motor                                 | 58AA            | 8094935   | EAMM-A-T42-58AA |
| EMMT-AS-60-..., EMMB-AS-60-..., third-party motor | 60P, 60PA       | ★ 4133487 | EAMM-A-T42-60P  |
| Third-party motor                                 | 60R             | 8093289   | EAMM-A-T42-60R  |
| Third-party motor                                 | 60RA            | 8092264   | EAMM-A-T42-60RA |
| EMMT-AS-80-..., EMMB-AS-80-..., third-party motor | 80P             | ★ 4623788 | EAMM-A-T42-80P  |
| <b>With stepper motor</b>                         |                 |           |                 |
| EMMT-ST-57, EMMB-ST-57-...                        | 57A             | ★ 4327034 | EAMM-A-T42-57A  |
| Third-party motor                                 | 60AA            | 8092255   | EAMM-A-T42-60AA |
| Third-party motor                                 | 60AB            | 8094949   | EAMM-A-T42-60AB |
| EMMT-ST-87, EMMB-ST-87-...                        | 87A             | ★ 4610008 | EAMM-A-T42-87A  |

1) The input torque must not exceed the max. permissible transferable torque of the axial kit.



## Product range overview

## Permitted axis/motor combinations with ball screw axis ELGC-BS-...

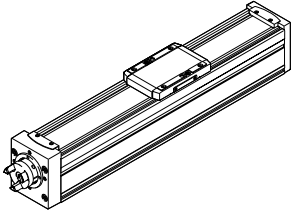

Table of interfaces for third-party motors

→ from page 64

Technical data for axial kits

→ from page 69

| Motor <sup>1)</sup><br>Type                              | Motor interface | Axial kit |                 |
|--|-----------------|-----------|-----------------|
|  |                 | Part no.  | Type            |
| <b>ELGC-BS-...-80</b>                                    |                 |           |                 |
| <b>With servo motor</b>                                  |                 |           |                 |
| <b>EMMT-AS-60-..., EMMB-AS-60-..., third-party motor</b> | 60P, 60PA       | ★ 4824833 | EAMM-A-T46-60P  |
| Third-party motor  | 60R             | 8126174   | EAMM-A-T46-60R  |
| Third-party motor  | 60RA            | 8126174   | EAMM-A-T46-60RA |
| Third-party motor  | 70A             | 8092674   | EAMM-A-T46-70A  |
| Third-party motor  | 70AA, 70AB      | 8096057   | EAMM-A-T46-70AA |
| <b>EMMT-AS-80-..., EMMB-AS-80-..., third-party motor</b> | 80P             | ★ 4624170 | EAMM-A-T46-80P  |
| Third-party motor  | 80PA, 80RA      | 8091047   | EAMM-A-T46-80PA |
| Third-party motor  | 80PB, 80R       | 8096175   | EAMM-A-T46-80PB |
| <b>EMMT-AS-100-..., third-party motor</b>                | 100A            | ★ 4624227 | EAMM-A-T46-100A |
| <b>With stepper motor</b>                                |                 |           |                 |
| Third-party motor  | 85AA            | 8096186   | EAMM-A-T46-85AA |
| <b>EMMT-ST-57, EMMB-ST-57-...</b>                        | 57A             | 8169409   | EAMM-A-T46-57A  |
| <b>EMMT-ST-87, EMMB-ST-87-...</b>                        | 87A             | ★ 4048771 | EAMM-A-T46-87A  |

1) The input torque must not exceed the max. permissible transferable torque of the axial kit.

## Product range overview

### Permissible axis/motor combinations with toothed belt axis EGC-HD-TB

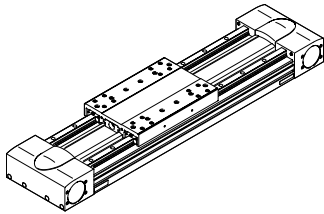

Table of interfaces for third-party motors

→ from page 64

Technical data for axial kits

→ from page 69

| Motor/gear unit <sup>1)</sup><br>Type                | Motor interface | Axial kit |                 |
|--|-----------------|-----------|-----------------|
|  |                 | Part no.  | Type            |
| <b>EGC-HD-125-...-TB</b>                             |                 |           |                 |
| <b>With servo motor</b>                              |                 |           |                 |
| Third-party motor                                    | 55A             | 8063533   | EAMM-A-M43-55A  |
| Third-party motor                                    | 70A             | 8063534   | EAMM-A-M43-70A  |
| Third-party motor                                    | 70AA, 70AB      | 8063535   | EAMM-A-M43-70AA |
| Third-party motor                                    | 90R             | 8063537   | EAMM-A-M43-90R  |
| Third-party motor                                    | 92RA            | 8063538   | EAMM-A-M43-92RA |
| <b>With servo motor and gear unit</b>                |                 |           |                 |
| EMME-AS-40-...<br>EMGA-40-P-G...-EAS-40              | 40G             | 8063539   | EAMM-A-M43-40G  |
| EMMT-AS-60-...<br>EMGA-60-P-G...-EAS-60              | 60H             | 1456612   | EAMM-A-M43-60H  |
| <b>With servo motor and right-angle gear unit</b>    |                 |           |                 |
| EMME-AS-40-..., EMMB-AS-40-...<br>EMGA-40-A-G...-40P | 40P             | 8063539   | EAMM-A-M43-40P  |
| EMMT-AS-60-..., EMMB-AS-60-...<br>EMGA-60-A-G...-60P | 60H             | 1456612   | EAMM-A-M43-60H  |
| <b>With stepper motor and gear unit</b>              |                 |           |                 |
| EMMT-ST-57, EMMB-ST-57-...<br>EMGA-60-P-G...-SST-57  | 60G             | 1190076   | EAMM-A-M43-60G  |
| <b>With third-party gear unit</b>                    |                 |           |                 |
| Third-party gear unit                                | 40G             | 8063539   | EAMM-A-M43-40G  |
| Third-party gear unit                                | 50GA            | 8063540   | EAMM-A-M43-50GA |
| Third-party gear unit                                | 56GA            | 8063541   | EAMM-A-M43-56GA |
| Third-party gear unit                                | 60H             | 1456612   | EAMM-A-M43-60H  |
| Third-party gear unit                                | 68GA            | 8063544   | EAMM-A-M43-68GA |
| Third-party gear unit                                | 70GA            | 8063542   | EAMM-A-M43-70GA |
| Third-party gear unit                                | 72GA            | 8063545   | EAMM-A-M43-72GA |

1) The input torque must not exceed the max. permissible transferable torque of the axial kit.

## Product range overview

## Permissible axis/motor combinations with toothed belt axis EGC-HD-TB

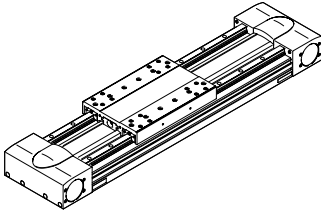

Table of interfaces for third-party motors

→ from page 64

Technical data for axial kits

→ from page 69

| Motor/gear unit <sup>1)</sup>                        | Motor interface | Axial kit |                  |
|--|-----------------|-----------|------------------|
|  |                 | Part no.  | Type             |
| <b>EGC-HD-160-...-TB</b>                             |                 |           |                  |
| <b>With servo motor</b>                              |                 |           |                  |
| Third-party motor                                    | 84AA            | 8063548   | EAMM-A-M48-84AA  |
| Third-party motor                                    | 88A             | 8063547   | EAMM-A-M48-88A   |
| <b>With servo motor and gear unit</b>                |                 |           |                  |
| EMME-AS-40-...<br>EMGA-40-P-G...-EAS-40              | 40G             | 8063549   | EAMM-A-M48-40G   |
| EMMT-AS-60-...<br>EMGA-60-P-G...-EAS-60              | 60H             | 1456614   | EAMM-A-M48-60H   |
| EMMT-AS-80-...<br>EMGA-80-P-G...-EAS-80              | 80G             | 1190421   | EAMM-A-M48-80G   |
| EMMT-AS-100-...<br>EMGA-80-P-G...-SAS-100            | 80G             | 1190421   | EAMM-A-M48-80G   |
| <b>With servo motor and right-angle gear unit</b>    |                 |           |                  |
| EMME-AS-40-..., EMMB-AS-40-...<br>EMGA-40-A-G...-40P | 40P             | 8063549   | EAMM-A-M48-40P   |
| EMMT-AS-60-..., EMMB-AS-60-...<br>EMGA-60-A-G...-60P | 60H             | 1456614   | EAMM-A-M48-60H   |
| EMMT-AS-80-..., EMMB-AS-80-...<br>EMGA-80-A-G...-80P | 80G             | 1190421   | EAMM-A-M48-80G   |
| EMMT-AS-100-...<br>EMGA-80-A-G...-100A               | 80G             | 1190421   | EAMM-A-M48-80G   |
| <b>With stepper motor and gear unit</b>              |                 |           |                  |
| EMMT-ST-57, EMMB-ST-57-...<br>EMGA-60-P-G...-SST-57  | 60G             | 8063552   | EAMM-A-M48-60G   |
| EMMT-ST-87, EMMB-ST-87-...<br>EMGA-80-P-G...-SST-87  | 80G             | 1190421   | EAMM-A-M48-80G   |
| <b>With third-party gear unit</b>                    |                 |           |                  |
| Third-party gear unit                                | 40G             | 8063549   | EAMM-A-M48-40G   |
| Third-party gear unit                                | 50GA            | 8063550   | EAMM-A-M48-50GA  |
| Third-party gear unit                                | 56GA            | 8063551   | EAMM-A-M48-56GA  |
| Third-party gear unit                                | 60H             | 1456614   | EAMM-A-M48-60H   |
| Third-party gear unit                                | 68GA            | 8063556   | EAMM-A-M48-68GA  |
| Third-party gear unit                                | 70GA            | 8063553   | EAMM-A-M48-70GA  |
| Third-party gear unit                                | 72GA            | 8063557   | EAMM-A-M48-72GA  |
| Third-party gear unit                                | 75GA            | 8063554   | EAMM-A-M48-75GA  |
| Third-party gear unit                                | 90GA            | 8063559   | EAMM-A-M48-90GA  |
| Third-party gear unit                                | 90GB            | 8063558   | EAMM-A-M48-90GB  |
| Third-party gear unit                                | 120GA           | 8063561   | EAMM-A-M48-120GA |

1) The input torque must not exceed the max. permissible transferable torque of the axial kit.

## Product range overview

### Permissible axis/motor combinations with toothed belt axis EGC-HD-TB

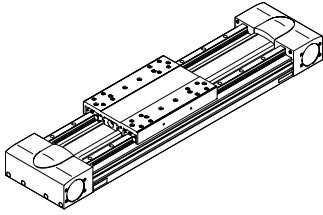

Table of interfaces for third-party motors

→ from page 64

Technical data for axial kits

→ from page 69

| Motor/gear unit <sup>1)</sup><br>Type      | Motor interface | Axial kit |                  |
|--|-----------------|-----------|------------------|
|  |                 | Part no.  | Type             |
| <b>EGC-HD-220-...-TB</b>                   |                 |           |                  |
| <b>With servo motor</b>                    |                 |           |                  |
| Third-party motor                          | 84AA            | 8063563   | EAMM-A-M80-84AA  |
| <b>With servo motor and gear unit</b>      |                 |           |                  |
| EMMT-AS-80-...<br>EMGA-80-P-G...-EAS-80    | 80G             | 8063565   | EAMM-A-M80-80G   |
| EMMT-AS-100-...<br>EMGA-80-P-G...-SAS-100  | 80G             | 8063565   | EAMM-A-M80-80G   |
| EMMT-AS-100-...<br>EMGA-120-P-G...-SAS-100 | 120G            | 1190774   | EAMM-A-M80-120G  |
| EMMT-AS-150-...<br>EMGA-120-P-G...-SAS-140 | 120G            | 1190774   | EAMM-A-M80-120G  |
| <b>With third-party gear unit</b>          |                 |           |                  |
| Third-party gear unit                      | 68GA            | 8063566   | EAMM-A-M80-68GA  |
| Third-party gear unit                      | 75GA            | 8063564   | EAMM-A-M80-75GA  |
| Third-party gear unit                      | 80G             | 8063565   | EAMM-A-M80-80G   |
| Third-party gear unit                      | 90GA            | 8063568   | EAMM-A-M80-90GA  |
| Third-party gear unit                      | 90GB            | 8063567   | EAMM-A-M80-90GB  |
| Third-party gear unit                      | 115GA           | 8063569   | EAMM-A-M80-115GA |
| Third-party gear unit                      | 120G            | 1190774   | EAMM-A-M80-120G  |
| Third-party gear unit                      | 120GA           | 8063571   | EAMM-A-M80-120GA |
| Third-party gear unit                      | 120GB           | 8063572   | EAMM-A-M80-120GB |
| Third-party gear unit                      | 120GC           | 8063573   | EAMM-A-M80-120GC |

1) The input torque must not exceed the max. permissible transferable torque of the axial kit.

## Product range overview

## Permitted axis/motor combinations with ball screw axis EGC-HD-BS

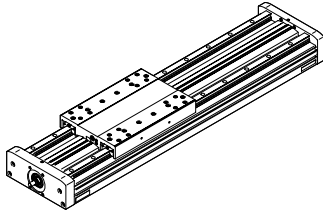

Table of interfaces for third-party motors

→ from page 64

Technical data for axial kits

→ from page 69

| Motor/gear unit <sup>1)</sup><br>Type                | Motor interface | Axial kit |                    |
|--|-----------------|-----------|--------------------|
|  |                 | Part no.  | Type               |
| <b>EGC-HD-125-...-BS</b>                             |                 |           |                    |
| <b>With servo motor</b>                              |                 |           |                    |
| EMME-AS-40-..., EMMB-AS-40-...                       | 40P             | ★ 3637972 | EAMM-A-S38-40P-G2  |
| Third-party motor                                    | 40A             | 3637971   | EAMM-A-S38-40A-G2  |
| Third-party motor                                    | 55A             | 8197483   | EAMM-A-S38-55A-G3  |
| Third-party motor                                    | 58AA            | 8105927   | EAMM-A-S38-58AA    |
| EMMT-AS-60-..., EMMB-AS-60-..., third-party motor    | 60P             | 8197479   | EAMM-A-S38-60P-G3  |
| Third-party motor                                    | 60R             | 8197475   | EAMM-A-S38-60R-G2  |
| Third-party motor                                    | 60RA            | 8197484   | EAMM-A-S38-60RA-G2 |
| <b>With servo motor and gear unit</b>                |                 |           |                    |
| EMME-AS-40-...<br>EMGA-40-P-G...-EAS-40              | 40G             | 1456647   | EAMM-A-S38-40G-G2  |
| <b>With servo motor and right-angle gear unit</b>    |                 |           |                    |
| EMME-AS-40-..., EMMB-AS-40-...<br>EMGA-40-A-G...-40P | 40G             | 1456647   | EAMM-A-S38-40G-G2  |
| <b>With stepper motor</b>                            |                 |           |                    |
| EMMT-ST-42, EMMB-ST-42-..., third-party motor        | 42A             | ★ 3637965 | EAMM-A-S38-42A-G2  |
| EMMT-ST-57, EMMB-ST-57-...                           | 57A             | ★ 3637956 | EAMM-A-S38-57A-G2  |
| Third-party motor                                    | 60AA            | 8105926   | EAMM-A-S38-60AA    |
| <b>With stepper motor and gear unit</b>              |                 |           |                    |
| EMMT-ST-42, EMMB-ST-42-...<br>EMGA-40-P-G...-SST-42  | 40G             | 1456647   | EAMM-A-S38-40G-G2  |
| <b>With third-party gear unit</b>                    |                 |           |                    |
| Third-party gear unit                                | 40G             | 1456647   | EAMM-A-S38-40G-G2  |
| Third-party gear unit                                | 50GA            | 8105922   | EAMM-A-S38-50GA    |

1) The input torque must not exceed the max. permissible transferable torque of the axial kit.

## Product range overview

## Permitted axis/motor combinations with ball screw axis EGC-HD-BS

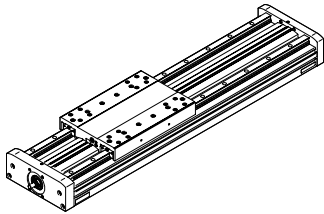

Table of interfaces for third-party motors

→ from page 64

Technical data for axial kits

→ from page 69

| Motor/gear unit <sup>1)</sup>                        | Motor interface | Axial kit |                    |
|--|-----------------|-----------|--------------------|
|  |                 | Part no.  | Type               |
| <b>EGC-HD-160-...-BS</b>                             |                 |           |                    |
| <b>With servo motor</b>                              |                 |           |                    |
| Third-party motor                                    | 55A             | 3637961   | EAMM-A-S48-55A-G2  |
| Third-party motor                                    | 58AA            | 8105933   | EAMM-A-S48-58AA    |
| EMMT-AS-60-..., EMMB-AS-60-..., third-party motor    | 60P             | 8197481   | EAMM-A-S48-60P-G3  |
| Third-party motor                                    | 60R             | 8197485   | EAMM-A-S48-60R-G2  |
| Third-party motor                                    | 60RA            | 8197474   | EAMM-A-S48-60RA-G2 |
| Third-party motor                                    | 70A             | 3637957   | EAMM-A-S48-70A-G2  |
| Third-party motor                                    | 70AA, 70AB      | 8105942   | EAMM-A-S48-70AA    |
| EMMT-AS-80-..., EMMB-AS-80-..., third-party motor    | 80P, 80PA, 80RA | 8197480   | EAMM-A-S48-80P     |
| Third-party motor                                    | 80PB, 80R       | 8197487   | EAMM-A-S48-80PB    |
| <b>With servo motor and gear unit</b>                |                 |           |                    |
| EMME-AS-40-...<br>EMGA-40-P-G...-EAS-40              | 40G             | 1456650   | EAMM-A-S48-40G-G2  |
| EMMT-AS-60-...<br>EMGA-60-P-G...-EAS-60              | 60H             | 8197482   | EAMM-A-S48-60H-G3  |
| <b>With servo motor and right-angle gear unit</b>    |                 |           |                    |
| EMME-AS-40-..., EMMB-AS-40-...<br>EMGA-40-A-G...-40P | 40G             | 1456650   | EAMM-A-S48-40G-G2  |
| EMMT-AS-60-..., EMMB-AS-60-...<br>EMGA-60-A-G...-60P | 60H             | 8197482   | EAMM-A-S48-60H-G3  |
| <b>With stepper motor</b>                            |                 |           |                    |
| EMMT-ST-57, EMMB-ST-57-...<br>Third-party motor      | 57A             | ★ 3637963 | EAMM-A-S48-57A-G2  |
| Third-party motor                                    | 60AA            | 8105935   | EAMM-A-S48-60AA    |
| EMMT-ST-87, EMMB-ST-87-...<br>Third-party motor      | 87A             | ★ 3637962 | EAMM-A-S48-87A-G2  |
| <b>With stepper motor and gear unit</b>              |                 |           |                    |
| EMMT-ST-42, EMMB-ST-42-...<br>EMGA-40-P-G...-SST-42  | 40G             | 1456650   | EAMM-A-S48-40G-G2  |
| EMMT-ST-57, EMMB-ST-57-...<br>EMGA-60-P-G...-SST-57  | 60G             | 8197477   | EAMM-A-S48-60G-G3  |
| <b>With third-party gear unit</b>                    |                 |           |                    |
| Third-party gear unit                                | 40G             | 1456650   | EAMM-A-S48-40G-G2  |
| Third-party gear unit                                | 50GA            | 8105930   | EAMM-A-S48-50GA    |
| Third-party gear unit                                | 60H             | 8197482   | EAMM-A-S48-60H-G3  |

1) The input torque must not exceed the max. permissible transferable torque of the axial kit.

## Product range overview

## Permitted axis/motor combinations with ball screw axis EGC-HD-BS

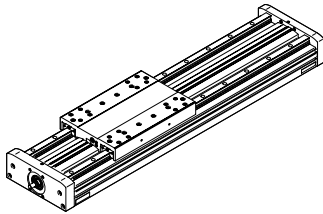

Table of interfaces for third-party motors

→ from page 64

Technical data for axial kits

→ from page 69

| Motor/gear unit <sup>1)</sup><br>Type                | Motor interface | Axial kit |                    |
|--|-----------------|-----------|--------------------|
|  |                 | Part no.  | Type               |
| <b>EGC-HD-220-...-BS</b>                             |                 |           |                    |
| <b>With servo motor</b>                              |                 |           |                    |
| Third-party motor                                    | 70A             | 3637959   | EAMM-A-S62-70A-G2  |
| EMMT-AS-80-..., EMMB-AS-80-..., third-party motor    | 80P             | ★ 3637970 | EAMM-A-S62-80P-G2  |
| Third-party motor                                    | 80PB, 80R       | 8110208   | EAMM-A-S62-80PB    |
| Third-party motor                                    | 82AA            | 8110211   | EAMM-A-S62-82AA    |
| Third-party motor                                    | 84AA            | 8110226   | EAMM-A-S62-84AA    |
| EMMT-AS-100-..., third-party motor                   | 100A            | 8197486   | EAMM-A-S62-100A-G3 |
| EMMT-AS-150  | 150A            | 8157272   | EAMM-A-S62-150A-G2 |
| <b>With servo motor and gear unit</b>                |                 |           |                    |
| EMMT-AS-60-...<br>EMGA-60-P-G...-EAS-60              | 60H             | 1456654   | EAMM-A-S62-60H-G2  |
| EMMT-AS-80-...<br>EMGA-80-P-G...-EAS-80              | 80G             | 8197473   | EAMM-A-S62-80G-G3  |
| EMMT-AS-100-...<br>EMGA-80-P-G...-SAS-100            | 80G             | 8197473   | EAMM-A-S62-80G-G3  |
| <b>With servo motor and right-angle gear unit</b>    |                 |           |                    |
| EMMT-AS-60-..., EMMB-AS-60-...<br>EMGA-60-A-G...-60P | 60H             | 1456654   | EAMM-A-S62-60H-G2  |
| EMMT-AS-80-..., EMMB-AS-80-...<br>EMGA-80-A-G...-80P | 80G             | 8197473   | EAMM-A-S62-80G-G3  |
| EMMT-AS-100-...<br>EMGA-80-A-G...-100A               | 80G             | 8197473   | EAMM-A-S62-80G-G3  |
| <b>With stepper motor</b>                            |                 |           |                    |
| EMMT-ST-87, EMMB-ST-87-...                           | 87A             | ★ 3637966 | EAMM-A-S62-87A-G2  |
| <b>With stepper motor and gear unit</b>              |                 |           |                    |
| EMMT-ST-57, EMMB-ST-57-...<br>EMGA-60-P-G...-SST-57  | 60G             | 2297649   | EAMM-A-S62-60G-G2  |
| EMMT-ST-87, EMMB-ST-87-...<br>EMGA-80-P-G...-SST-87  | 80G             | 8197473   | EAMM-A-S62-80G-G3  |
| <b>With third-party gear unit</b>                    |                 |           |                    |
| Third-party gear unit                                | 60H             | 1456654   | EAMM-A-S62-60H-G2  |
| Third-party gear unit                                | 70GA            | 8110082   | EAMM-A-S62-70GA    |
| Third-party gear unit                                | 80G             | 8197473   | EAMM-A-S62-80G-G3  |

1) The input torque must not exceed the max. permissible transferable torque of the axial kit.

## Product range overview

### Permissible axis/motor combinations with cantilever axis ELCC-TB-...

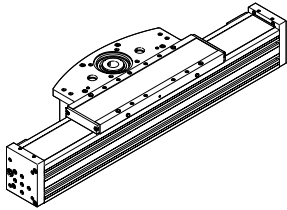

Table of interfaces for third-party motors

→ from page 64

Technical data for axial kits

→ from page 69

| Motor/gear unit <sup>1)</sup>                        | Motor interface | Axial kit |                    |
|--|-----------------|-----------|--------------------|
|  |                 | Part no.  | Type               |
| <b>ELCC-TB-...-60</b>                                |                 |           |                    |
| <b>With servo motor</b>                              |                 |           |                    |
| EMMT-AS-60-..., EMMB-AS-60-..., third-party motor    | 60P, 60PA       | 8197468   | EAMM-A-N48-60P     |
| Third-party motor                                    | 70AA, 70AB      | 8063591   | EAMM-A-N48-70AA    |
| EMMT-AS-80-..., EMMB-AS-80-..., third-party motor    | 80P             | 8063592   | EAMM-A-N48-80P     |
| Third-party motor                                    | 80PB, 80R       | 8107714   | EAMM-A-N48-80PB    |
| Third-party motor                                    | 84AA            | 8063594   | EAMM-A-N48-84AA    |
| Third-party motor                                    | 88A             | 8063593   | EAMM-A-N48-88A     |
| <b>With servo motor and gear unit</b>                |                 |           |                    |
| EMME-AS-40-...<br>EMGA-40-P-G...-EAS-40              | 40G             | 8197467   | EAMM-A-N48-40G     |
| EMMT-AS-60<br>EMGA-60-P-G...-EAS-60                  | 60H             | 8197465   | EAMM-A-N48-60H-G2  |
| EMMT-AS-80-...<br>EMGA-80-P-G...-EAS-80              | 80G             | 8197470   | EAMM-A-N48-80G-G2  |
| <b>With servo motor and right-angle gear unit</b>    |                 |           |                    |
| EMMT-AS-60-..., EMMB-AS-60-...<br>EMGA-60-A-G...-60P | 60H             | 8197465   | EAMM-A-N48-60H-G2  |
| EMMT-AS-80-..., EMMB-AS-80-...<br>EMGA-80-A-G...-80P | 80G             | 8197470   | EAMM-A-N48-80G-G2  |
| <b>With stepper motor</b>                            |                 |           |                    |
| EMMT-ST-87, EMMB-ST-87-...                           | 87A             | 8197466   | EAMM-A-N48-87A     |
| <b>ELCC-TB-...-70</b>                                |                 |           |                    |
| <b>With servo motor</b>                              |                 |           |                    |
| EMMT-AS-100-..., third-party motor                   | 100A            | 8197464   | EAMM-A-N48-100A-G2 |
| <b>With servo motor and gear unit</b>                |                 |           |                    |
| EMMT-AS-80-...<br>EMGA-80-P-G...-EAS-80              | 80G             | 8197470   | EAMM-A-N48-80G-G2  |
| EMMT-AS-100-...<br>EMGA-80-P-G...-SAS-100            | 80G             | 8197470   | EAMM-A-N48-80G-G2  |
| <b>With servo motor and right-angle gear unit</b>    |                 |           |                    |
| EMMT-AS-80-..., EMMB-AS-80-...<br>EMGA-80-A-G...-80P | 80G             | 8197470   | EAMM-A-N48-80G-G2  |
| EMMT-AS-100-...<br>EMGA-80-A-G...-100A               | 80G             | 8197470   | EAMM-A-N48-80G-G2  |
| <b>With third-party gear unit</b>                    |                 |           |                    |
| Third-party gear unit                                | 50GA            | 8063595   | EAMM-A-N48-50GA    |
| Third-party gear unit                                | 56GA            | 8063596   | EAMM-A-N48-56GA    |
| Third-party gear unit                                | 70GA            | 8199479   | EAMM-A-N48-70GA-G2 |
| Third-party gear unit                                | 72GA            | 8063601   | EAMM-A-N48-72GA    |
| Third-party gear unit                                | 75GA            | 8063598   | EAMM-A-N48-75GA    |
| Third-party gear unit                                | 90GA            | 8063603   | EAMM-A-N48-90GA    |
| Third-party gear unit                                | 90GB            | 8063602   | EAMM-A-N48-90GB    |
| Third-party gear unit                                | 120GA           | 8063605   | EAMM-A-N48-120GA   |
| <b>With stepper motor</b>                            |                 |           |                    |
| EMMT-ST-87, EMMB-ST-87-...                           | 87A             | 8197466   | EAMM-A-N48-87A     |

1) The input torque must not exceed the max. permissible transferable torque of the axial kit.



## Product range overview

## Permissible axis/motor combinations with cantilever axis ELCC-TB-...

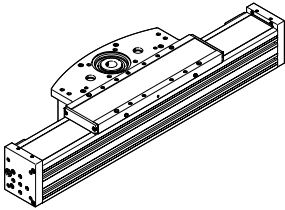

Table of interfaces for third-party motors

→ from page 64

Technical data for axial kits

→ from page 69

| Motor/gear unit <sup>1)</sup><br>Type             | Motor interface | Axial kit |                    |
|---|-----------------|-----------|--------------------|
|   |                 | Part no.  | Type               |
| <b>ELCC-TB-...-90</b>                             |                 |           |                    |
| <b>With servo motor</b>                           |                 |           |                    |
| EMMT-AS-100-..., third-party motor                | 100A            | 8063607   | EAMM-A-N80-100A    |
| EMMT-AS-150-...                                   | 150A            | 8157277   | EAMM-A-N80-150A    |
| <b>With servo motor and gear unit</b>             |                 |           |                    |
| EMMT-AS-100-...<br>EMGA-80-P-G...-SAS-100         | 80G             | 8197471   | EAMM-A-N80-80G-G2  |
| <b>With servo motor and right-angle gear unit</b> |                 |           |                    |
| EMMT-AS-100-...<br>EMGA-80-A-...-100A             | 80G             | 8197471   | EAMM-A-N80-80G-G2  |
| <b>With third-party gear unit</b>                 |                 |           |                    |
| Third-party gear unit                             | 68GA            | 8063611   | EAMM-A-N80-68GA    |
| Third-party gear unit                             | 70GA            | 8063608   | EAMM-A-N80-70GA    |
| Third-party gear unit                             | 72GA            | 8063612   | EAMM-A-N80-72GA    |
| Third-party gear unit                             | 75GA            | 8063609   | EAMM-A-N80-75GA    |
| Third-party gear unit                             | 90GA            | 8063614   | EAMM-A-N80-90GA    |
| Third-party gear unit                             | 90GB            | 8063613   | EAMM-A-N80-90GB    |
| Third-party gear unit                             | 115GA           | 8063615   | EAMM-A-N80-115GA   |
| Third-party gear unit                             | 120GA           | 8063617   | EAMM-A-N80-120GA   |
| Third-party gear unit                             | 120GB           | 8063618   | EAMM-A-N80-120GB   |
| Third-party gear unit                             | 120GC           | 8063619   | EAMM-A-N80-120GC   |
| <b>ELCC-TB-...-110</b>                            |                 |           |                    |
| <b>With servo motor and gear unit</b>             |                 |           |                    |
| EMMT-AS-100-...<br>EMGA-80-P-G...-SAS-100         | 80G             | 3660191   | EAMM-A-L95-80G-G2  |
| EMMT-AS-100-...<br>EMGA-120-P-G...-SAS-100        | 120G            | ★ 3659941 | EAMM-A-L95-120G-G2 |
| EMMT-AS-150-...<br>EMGA-120-P-G...-SAS-140        | 120G            | ★ 3659941 | EAMM-A-L95-120G-G2 |
| EMMT-AS-150-...<br>EMGA-160-P-G...-SAS-140        | 160G            | 8197453   | EAMM-A-L95-160G-G2 |
| <b>With servo motor and right-angle gear unit</b> |                 |           |                    |
| EMMT-AS-100-...<br>EMGA-80-A-G...-100A            | 80G             | 3660191   | EAMM-A-L95-80G-G2  |
| <b>With third-party gear unit</b>                 |                 |           |                    |
| Third-party gear unit                             | 68GA            | 8063524   | EAMM-A-L95-68GA    |
| Third-party gear unit                             | 72GA            | 8063525   | EAMM-A-L95-72GA    |
| Third-party gear unit                             | 75GA            | 8063522   | EAMM-A-L95-75GA    |
| Third-party gear unit                             | 90GA            | 8063526   | EAMM-A-L95-90GA    |
| Third-party gear unit                             | 115GA           | 8063527   | EAMM-A-L95-115GA   |
| Third-party gear unit                             | 120GA           | 8063529   | EAMM-A-L95-120GA   |
| Third-party gear unit                             | 120GB           | 8063530   | EAMM-A-L95-120GB   |
| Third-party gear unit                             | 120GC           | 8063531   | EAMM-A-L95-120GC   |

1) The input torque must not exceed the max. permissible transferable torque of the axial kit.

## Product range overview

### Permissible axis/motor combinations with mini slide EGSL

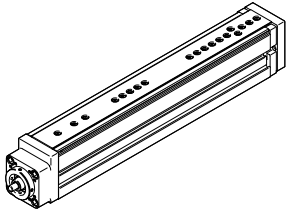

Table of interfaces for third-party motors

→ from page 64

Technical data for axial kits

→ from page 69

| Motor/gear unit <sup>1)</sup><br>Type                | Motor interface | Axial kit |                   |
|--|-----------------|-----------|-------------------|
|  |                 | Part no.  | Type              |
| <b>EGSL-35</b>                                       |                 |           |                   |
| <b>With servo motor</b>                              |                 |           |                   |
| Third-party motor                                    | 38AA            | 8105863   | EAMM-A-D19-38AA   |
| EMME-AS-40-..., EMMB-AS-40-...                       | 40P             | 1981953   | EAMM-A-D19-40P    |
| Third-party motor                                    | 40A             | 1199152   | EAMM-A-D19-40A    |
| Third-party motor                                    | 40R             | 8105867   | EAMM-A-D19-40R    |
| <b>With stepper motor</b>                            |                 |           |                   |
| EMMS-ST-28-...                                       | 28A             | 1081659   | EAMM-A-D19-28A    |
| EMMT-ST-42, EMMB-ST-42-..., third-party motor        | 42A             | 1087642   | EAMM-A-D19-42A    |
| <b>EGSL-45</b>                                       |                 |           |                   |
| <b>With servo motor</b>                              |                 |           |                   |
| Third-party motor                                    | 40A             | 543147    | EAMM-A-D32-40A    |
| EMME-AS-40-..., EMMB-AS-40-...                       | 40P             | ★ 1976465 | EAMM-A-D32-40P    |
| Third-party motor                                    | 40R             | 8105826   | EAMM-A-D32-40R    |
| Third-party motor                                    | 40RA            | 8125610   | EAMM-A-D32-40RA   |
| Third-party motor                                    | 55A             | 550979    | EAMM-A-D32-55A    |
| Third-party motor                                    | 58AA            | 8105884   | EAMM-A-D32-58AA   |
| EMMT-AS-60-..., EMMB-AS-60-..., third-party motor    | 60P             | 8197499   | EAMM-A-D32-60P-G2 |
| Third-party motor                                    | 60R             | 8105918   | EAMM-A-D32-60R    |
| Third-party motor                                    | 60RA            | 8105889   | EAMM-A-D32-60RA   |
| <b>With servo motor and gear unit</b>                |                 |           |                   |
| EMME-AS-40-...<br>EMGA-40-P-G...-EAS-40              | 40G             | 1454238   | EAMM-A-D32-40G    |
| EMMT-AS-60-...<br>EMGA-60-P-G...-EAS-60              | 60H             | 2946760   | EAMM-A-D32-60H    |
| <b>With servo motor and right-angle gear unit</b>    |                 |           |                   |
| EMME-AS-40-..., EMMB-AS-40-...<br>EMGA-40-A-G...-40P | 40G             | 1454238   | EAMM-A-D32-40G    |
| EMMT-AS-60-..., EMMB-AS-60-...<br>EMGA-60-A-G...-60P | 60H             | 2946760   | EAMM-A-D32-60H    |

1) The input torque must not exceed the max. permissible transferable torque of the axial kit.

## Product range overview

## Permissible axis/motor combinations with mini slide EGSL

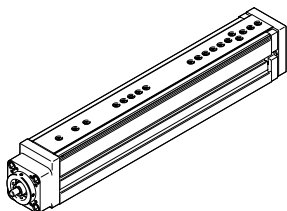

Table of interfaces for third-party motors

→ from page 64

Technical data for axial kits

→ from page 69

| Motor/gear unit <sup>1)</sup><br>Type                       | Motor interface | Axial kit |                 |
|---|-----------------|-----------|-----------------|
|   |                 | Part no.  | Type            |
| <b>EGSL-45</b>  |                 |           |                 |
| <b>With stepper motor</b>                                   |                 |           |                 |
| <b>EMMT-ST-42, EMMB-ST-42-..., third-party motor</b>        | 42A             | ★ 543148  | EAMM-A-D32-42A  |
| <b>EMMT-ST-57, EMMB-ST-57-...</b>                           | 57A             | ★ 550980  | EAMM-A-D32-57A  |
| <b>Third-party motor</b>                                    | 60AA            | 8105887   | EAMM-A-D32-60AA |
| <b>With stepper motor and gear unit</b>                     |                 |           |                 |
| <b>EMMT-ST-42, EMMB-ST-42-...<br/>EMGA-40-P-G...-SST-42</b> | 40G             | 1454238   | EAMM-A-D32-40G  |
| <b>EMMT-ST-57, EMMB-ST-57-...<br/>EMGA-60-P-G...-SST-57</b> | 60G             | 2946758   | EAMM-A-D32-60G  |
| <b>With third-party gear unit</b>                           |                 |           |                 |
| <b>Third-party gear unit</b>                                | 40G             | 1454238   | EAMM-A-D32-40G  |
| <b>Third-party gear unit</b>                                | 50GA            | 8117072   | EAMM-A-D32-50GA |
| <b>Third-party gear unit</b>                                | 60H             | 2946760   | EAMM-A-D32-60H  |

1) The input torque must not exceed the max. permissible transferable torque of the axial kit.

## Product range overview

### Permissible axis/motor combinations with mini slide EGSL

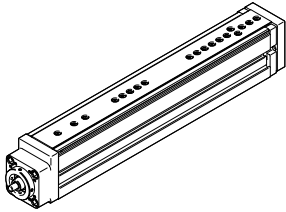

Table of interfaces for third-party motors

→ from page 64

Technical data for axial kits

→ from page 69

| Motor/gear unit <sup>1)</sup>                        | Motor interface | Axial kit |                                 |
|--|-----------------|-----------|---------------------------------|
|  |                 | Part no.  | Type                            |
| <b>EGSL-55</b>                                       |                 |           |                                 |
| <b>With servo motor</b>                              |                 |           |                                 |
| Third-party motor                                    | 55A             | 543153    | EAMM-A-D40-55A                  |
| Third-party motor                                    | 58AA            | 8105928   | EAMM-A-D40-58AA                 |
| EMMT-AS-60-..., EMMB-AS-60-..., third-party motor    | 60P             | 8197493   | EAMM-A-D40-60P-G2               |
| Third-party motor                                    | 60R             | 8117079   | EAMM-A-D40-60R                  |
| Third-party motor                                    | 60RA            | 8117078   | EAMM-A-D40-60RA                 |
| Third-party motor                                    | 70A             | 550981    | EAMM-A-D40-70A                  |
| Third-party motor                                    | 70AA, 70AB      | 8105952   | EAMM-A-D40-70AA                 |
| <b>With servo motor and gear unit</b>                |                 |           |                                 |
| EMME-AS-40-...<br>EMGA-40-P-G...-EAS-40              | 40G             | ★ 2256398 | EAMM-A-D40-40G-G2 <sup>2)</sup> |
| EMMT-AS-60-...<br>EMGA-60-P-G...-EAS-60              | 60H             | 1454242   | EAMM-A-D40-60H                  |
| <b>With servo motor and right-angle gear unit</b>    |                 |           |                                 |
| EMME-AS-40-..., EMMB-AS-40-...<br>EMGA-40-A-G...-40P | 40G             | ★ 2256398 | EAMM-A-D40-40G-G2 <sup>2)</sup> |
| EMMT-AS-60-..., EMMB-AS-60-...<br>EMGA-60-A-G...-60P | 60H             | 1454242   | EAMM-A-D40-60H                  |
| EMMB-AS-60-...<br>EMGA-60-A-G...-60P                 | 60H             | 1454242   | EAMM-A-D40-60H                  |
| <b>With stepper motor</b>                            |                 |           |                                 |
| EMMT-ST-57, EMMB-ST-57-...                           | 57A             | ★ 543154  | EAMM-A-D40-57A                  |
| Third-party motor                                    | 60AA            | 8105929   | EAMM-A-D40-60AA                 |
| EMMT-ST-87, EMMB-ST-87-...                           | 87A             | ★ 550982  | EAMM-A-D40-87A                  |
| <b>With stepper motor and gear unit</b>              |                 |           |                                 |
| EMMT-ST-42, EMMB-ST-42-...<br>EMGA-40-P-G...-SST-42  | 40G             | ★ 2256398 | EAMM-A-D40-40G-G2 <sup>2)</sup> |
| EMMT-ST-57, EMMB-ST-57-...<br>EMGA-60-P-G...-SST-57  | 60G             | 2256400   | EAMM-A-D40-60G                  |
| <b>With third-party gear unit</b>                    |                 |           |                                 |
| Third-party gear unit                                | 50GA            | 8117076   | EAMM-A-D40-50GA                 |
| Third-party gear unit                                | 60H             | 1454242   | EAMM-A-D40-60H                  |

1) The input torque must not exceed the max. permissible transferable torque of the axial kit.

2) The axial kit can be retrofitted from IP40 to IP65 with the help of a seal set EADS-F → page 110

## Product range overview

## Permissible axis/motor combinations with mini slide EGSL

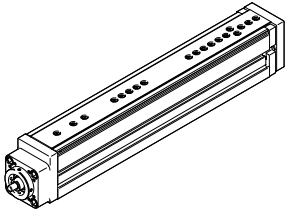

Table of interfaces for third-party motors

→ from page 64

Technical data for axial kits

→ from page 69

| Motor/gear unit <sup>1)</sup>                        | Motor interface | Axial kit |                                 |
|--|-----------------|-----------|---------------------------------|
|  |                 | Part no.  | Type                            |
| <b>EGSL-75</b>                                       |                 |           |                                 |
| <b>With servo motor</b>                              |                 |           |                                 |
| <b>Third-party motor</b>                             | 70A             | 543161    | EAMM-A-D60-70A                  |
| EMMT-AS-80-..., EMMB-AS-80-..., third-party motor    | 80P             | ★ 1977073 | EAMM-A-D60-80P                  |
| Third-party motor                                    | 80PB, 80R       | 8105937   | EAMM-A-D60-80PB                 |
| Third-party motor                                    | 84AA            | 8105945   | EAMM-A-D60-84AA                 |
| Third-party motor                                    | 92RA            | 8159834   | EAMM-A-D60-92RA                 |
| EMMT-AS-100-..., third-party motor                   | 100A            | 8197500   | EAMM-A-D60-100A-G2              |
| <b>With servo motor and gear unit</b>                |                 |           |                                 |
| EMMT-AS-60-...<br>EMGA-60-P-G...-EAS-60              | 60H             | 1454245   | EAMM-A-D60-60H                  |
| EMMT-AS-80-...<br>EMGA-80-P-G...-EAS-80              | 80G             | 8199480   | EAMM-A-D60-80G-G2               |
| EMMT-AS-100-...<br>EMGA-80-P-G...-SAS-100            | 80G             | 8199480   | EAMM-A-D60-80G-G2               |
| <b>With servo motor and right-angle gear unit</b>    |                 |           |                                 |
| EMMT-AS-60-..., EMMB-AS-60-...<br>EMGA-60-A-G...-60P | 60H             | 1454245   | EAMM-A-D60-60H                  |
| EMMT-AS-80-..., EMMB-AS-80-...<br>EMGA-80-A-G...-80P | 80G             | 8199480   | EAMM-A-D60-80G-G2               |
| EMMT-AS-100-...<br>EMGA-80-A-G...-100A               | 80G             | 8199480   | EAMM-A-D60-80G-G2               |
| <b>With stepper motor</b>                            |                 |           |                                 |
| EMMT-ST-87, EMMB-ST-87-...                           | 87A             | ★ 543162  | EAMM-A-D60-87A                  |
| <b>With stepper motor and gear unit</b>              |                 |           |                                 |
| EMMT-ST-57, EMMB-ST-57-...<br>EMGA-60-P-G...-SST-57  | 60G             | ★ 2256696 | EAMM-A-D60-60G-G2 <sup>3)</sup> |
| EMMT-ST-87, EMMB-ST-87-...<br>EMGA-80-P-G...-SST-87  | 80G             | 8199480   | EAMM-A-D60-80G-G2               |
| <b>With third-party gear unit</b>                    |                 |           |                                 |
| Third-party gear unit                                | 60H             | 1454245   | EAMM-A-D60-60H                  |
| Third-party gear unit                                | 80G             | 8199480   | EAMM-A-D60-80G-G2               |
| Third-party gear unit                                | 90GA            | 8105944   | EAMM-A-D60-90GA                 |

1) The input torque must not exceed the max. permissible transferable torque of the axial kit.

2) The axial kit can be retrofitted from IP40 to IP65 with the help of a seal set EADS-F → page 110

## Product range overview

### Permissible axis/motor combinations with mini slide EGSC

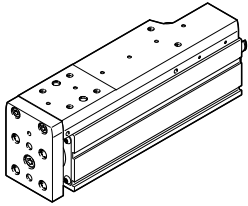

Table of interfaces for third-party motors

→ from page 64

Technical data for axial kits

→ from page 69

| Motor <sup>1)</sup><br>Type                   | Motor interface | Axial kit |                 |
|---|-----------------|-----------|-----------------|
|   |                 | Part no.  | Type            |
| <b>EGSC-25</b>                                |                 |           |                 |
| <b>With stepper motor</b>                     |                 |           |                 |
| EMMS-ST-28-...                                | 28A             | ★ 4505258 | EAMM-A-V20-28A  |
| Third-party motor                             | 28AA            | 8093016   | EAMM-A-V20-28AA |
| <b>EGSC-32</b>                                |                 |           |                 |
| <b>With servo motor</b>                       |                 |           |                 |
| Third-party motor                             | 38AA            | 8093162   | EAMM-A-V25-38AA |
| EMME-AS-40-..., EMMB-AS-40-...                | 40P             | ★ 4491059 | EAMM-A-V25-40P  |
| Third-party motor                             | 40R             | 8087062   | EAMM-A-V25-40R  |
| Third-party motor                             | 40RA            | 8094100   | EAMM-A-V25-40RA |
| <b>With stepper motor</b>                     |                 |           |                 |
| Third-party motor                             | 35A, 35AB       | 8093255   | EAMM-A-V25-35A  |
| EMMT-ST-42, EMMB-ST-42-..., third-party motor | 42A             | ★ 4582608 | EAMM-A-V25-42A  |
| Third-party motor                             | 42AB            | 8094108   | EAMM-A-V25-42AB |
| <b>EGSC-45</b>                                |                 |           |                 |
| <b>With servo motor</b>                       |                 |           |                 |
| Third-party motor                             | 38AA            | 8093023   | EAMM-A-V32-38AA |
| EMME-AS-40-..., EMMB-AS-40-...                | 40P             | ★ 4595742 | EAMM-A-V32-40P  |
| Third-party motor                             | 40R             | 8087090   | EAMM-A-V32-40R  |
| Third-party motor                             | 40RA            | 8094180   | EAMM-A-V32-40RA |
| Third-party motor                             | 58AA            | 8098982   | EAMM-A-V32-58AA |
| EMMT-AS-60-..., EMMB-AS-60-...                | 60P             | ★ 4608750 | EAMM-A-V32-60P  |
| Third-party motor                             | 60PA            | 8091053   | EAMM-A-V32-60PA |
| Third-party motor                             | 60RA            | 8093041   | EAMM-A-V32-60RA |
| <b>With stepper motor</b>                     |                 |           |                 |
| EMMT-ST-42, EMMB-ST-42-..., third-party motor | 42A             | ★ 4281142 | EAMM-A-V32-42A  |
| Third-party motor                             | 42AB            | 8094200   | EAMM-A-V32-42AB |
| EMMT-ST-57, EMMB-ST-57-...                    | 57A             | ★ 4597016 | EAMM-A-V32-57A  |
| Third-party motor                             | 60AA            | 8092271   | EAMM-A-V32-60AA |
| <b>EGSC-60</b>                                |                 |           |                 |
| <b>With servo motor</b>                       |                 |           |                 |
| Third-party motor                             | 55A             | 8082614   | EAMM-A-T42-55A  |
| Third-party motor                             | 58AA            | 8094935   | EAMM-A-T42-58AA |
| EMMT-AS-60-..., EMMB-AS-60-...                | 60P, 60PA       | ★ 4133487 | EAMM-A-T42-60P  |
| Third-party motor                             | 60R             | 8093289   | EAMM-A-T42-60R  |
| Third-party motor                             | 60RA            | 8092264   | EAMM-A-T42-60RA |
| EMMT-AS-80-..., EMMB-AS-80-...                | 80P             | ★ 4623788 | EAMM-A-T42-80P  |
| <b>With stepper motor</b>                     |                 |           |                 |
| EMMT-ST-57, EMMB-ST-57-...                    | 57A             | ★ 4327034 | EAMM-A-T42-57A  |
| Third-party motor                             | 60AA            | 8092255   | EAMM-A-T42-60AA |
| Third-party motor                             | 60AB            | 8094949   | EAMM-A-T42-60AB |
| EMMT-ST-87, EMMB-ST-87-...                    | 87A             | ★ 4610008 | EAMM-A-T42-87A  |

1) The input torque must not exceed the max. permissible transferable torque of the axial kit.

## Product range overview

## Permissible axis/motor combinations with electric slide EGSK

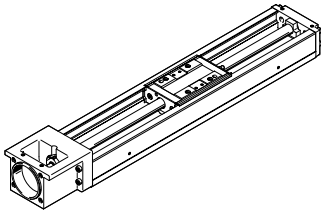

Table of interfaces for third-party motors

→ from page 64

Technical data for axial kits

→ from page 69

| Motor/gear unit <sup>1)</sup><br>Type             | Motor interface | Axial kit |                    |
|---|-----------------|-----------|--------------------|
|   |                 | Part no.  | Type               |
| <b>EGSK-15</b>                                    |                 |           |                    |
| <b>With servo motor</b>                           |                 |           |                    |
| EMME-AS-40-..., EMMB-AS-40-...                    | 40P             | 1982886   | EAMM-A-P3-28D-40P  |
| <b>With stepper motor</b>                         |                 |           |                    |
| EMMS-ST-28-...                                    | 28A             | 1703478   | EAMM-A-P3-28D-28A  |
| <b>EGSK-20</b>                                    |                 |           |                    |
| <b>With servo motor</b>                           |                 |           |                    |
| Third-party motor                                 | 38AA            | 8107704   | EAMM-A-P4-28B-38AA |
| Third-party motor                                 | 40A             | 562637    | EAMM-A-P4-28B-40A  |
| EMME-AS-40-..., EMMB-AS-40-...                    | 40P             | 1983071   | EAMM-A-P4-28B-40P  |
| Third-party motor                                 | 40R             | 8107707   | EAMM-A-P4-28B-40R  |
| Third-party motor                                 | 40RA            | 8107708   | EAMM-A-P4-28B-40RA |
| <b>With stepper motor</b>                         |                 |           |                    |
| EMMS-ST-28-...                                    | 28A             | 1731466   | EAMM-A-P4-28B-28A  |
| EMMT-ST-42, EMMB-ST-42-..., third-party motor     | 42A             | 562636    | EAMM-A-P4-28B-42A  |
| <b>EGSK-26</b>                                    |                 |           |                    |
| <b>With servo motor</b>                           |                 |           |                    |
| Third-party motor                                 | 38AA            | 8107710   | EAMM-A-P5-28B-38AA |
| Third-party motor                                 | 40A             | 562641    | EAMM-A-P5-28B-40A  |
| EMME-AS-40-..., EMMB-AS-40-...                    | 40P             | 1983122   | EAMM-A-P5-28B-40P  |
| Third-party motor                                 | 40R             | 8107711   | EAMM-A-P5-28B-40R  |
| Third-party motor                                 | 40RA            | 8107712   | EAMM-A-P5-28B-40RA |
| <b>With stepper motor</b>                         |                 |           |                    |
| EMMS-ST-28-...                                    | 28A             | 1731474   | EAMM-A-P5-28B-28A  |
| EMMT-ST-42, EMMB-ST-42-..., third-party motor     | 42A             | 562640    | EAMM-A-P5-28B-42A  |
| <b>EGSK-33</b>                                    |                 |           |                    |
| <b>With servo motor</b>                           |                 |           |                    |
| Third-party motor                                 | 40A             | 562646    | EAMM-A-P6-38A-40A  |
| EMME-AS-40-..., EMMB-AS-40-...                    | 40P             | 1983450   | EAMM-A-P6-38A-40P  |
| Third-party motor                                 | 55A             | 562647    | EAMM-A-P6-38A-55A  |
| Third-party motor                                 | 58AA            | 8123494   | EAMM-A-P6-38A-58AA |
| EMMT-AS-60-..., EMMB-AS-60-..., third-party motor | 60P             | 2264375   | EAMM-A-P6-38A-60P  |
| Third-party motor                                 | 60R             | 8123495   | EAMM-A-P6-38A-60R  |
| Third-party motor                                 | 60RA            | 8123496   | EAMM-A-P6-38A-60RA |
| <b>With servo motor and gear unit</b>             |                 |           |                    |
| EMME-AS-40-...                                    | 40G             | 2297645   | EAMM-A-P6-38A-40G  |
| EMGA-40-P-G...-EAS-40                             |                 |           |                    |

1) The input torque must not exceed the max. permissible transferable torque of the axial kit.

## Product range overview

### Permissible axis/motor combinations with electric slide EGSK

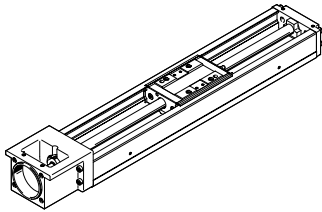

Table of interfaces for third-party motors

→ from page 64

Technical data for axial kits

→ from page 69

| Motor/gear unit <sup>1)</sup><br>Type               | Motor interface | Axial kit |                    |
|---|-----------------|-----------|--------------------|
|   |                 | Part no.  | Type               |
| <b>EGSK-33</b>                                      |                 |           |                    |
| <b>With stepper motor</b>                           |                 |           |                    |
| EMMT-ST-42, EMMB-ST-42-..., third-party motor       | 42A             | 562644    | EAMM-A-P6-38A-42A  |
| EMMT-ST-57, EMMB-ST-57-...                          | 57A             | 562645    | EAMM-A-P6-38A-57A  |
| <b>With stepper motor and gear unit</b>             |                 |           |                    |
| EMMT-ST-42, EMMB-ST-42-...<br>EMGA-40-P-G...-SST-42 | 40G             | 2297645   | EAMM-A-P6-38A-40G  |
| <b>EGSK-46</b>                                      |                 |           |                    |
| <b>With servo motor</b>                             |                 |           |                    |
| Third-party motor                                   | 40A             | 562652    | EAMM-A-P8-38A-40A  |
| EMME-AS-40-..., EMMB-AS-40-...                      | 40P             | 1986292   | EAMM-A-P8-38A-40P  |
| Third-party motor                                   | 55A             | 562653    | EAMM-A-P8-38A-55A  |
| Third-party motor                                   | 58AA            | 8105910   | EAMM-A-P8-38A-58AA |
| EMMT-AS-60-..., EMMB-AS-60-..., third-party motor   | 60P             | 1987308   | EAMM-A-P8-38A-60P  |
| Third-party motor                                   | 60R             | 8105916   | EAMM-A-P8-38A-60R  |
| Third-party motor                                   | 60RA            | 8105914   | EAMM-A-P8-38A-60RA |
| Third-party motor                                   | 70A             | 564996    | EAMM-A-P8-38A-70A  |
| Third-party motor                                   | 70AA, 70AB      | 8105920   | EAMM-A-P8-38A-70AA |
| <b>With servo motor and gear unit</b>               |                 |           |                    |
| EMME-AS-40-...<br>EMGA-40-P-G...-EAS-40             | 40G             | 2297646   | EAMM-A-P8-38A-40G  |
| <b>With stepper motor</b>                           |                 |           |                    |
| EMMT-ST-42, EMMB-ST-42-..., third-party motor       | 42A             | 562650    | EAMM-A-P8-38A-42A  |
| EMMT-ST-57, EMMB-ST-57-...                          | 57A             | 562651    | EAMM-A-P8-38A-57A  |
| Third-party motor                                   | 60AA            | 8105913   | EAMM-A-P8-38A-60AA |
| EMMT-ST-87, EMMB-ST-87-...                          | 87A             | 564998    | EAMM-A-P8-38A-87A  |
| <b>With stepper motor and gear unit</b>             |                 |           |                    |
| EMMT-ST-42, EMMB-ST-42-...<br>EMGA-40-P-G...-SST-42 | 40G             | 2297646   | EAMM-A-P8-38A-40G  |

1) The input torque must not exceed the max. permissible transferable torque of the axial kit.



## Product range overview

## Permissible axis/motor combinations with toothed belt axis ELGR, ELGG

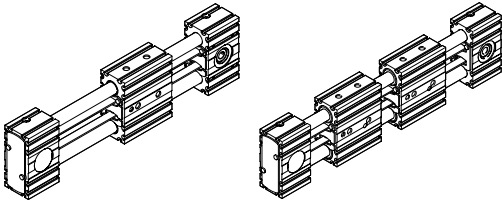

Table of interfaces for third-party motors

→ from page 64

Technical data for axial kits

→ from page 69

| Motor/gear unit <sup>1)</sup><br>Type                | Motor interface | Axial kit |                |
|--|-----------------|-----------|----------------|
|  |                 | Part no.  | Type           |
| <b>ELGR-35, ELGG-35</b>                              |                 |           |                |
| <b>With servo motor</b>                              |                 |           |                |
| Third-party motor                                    | 55A             | 1133400   | EAMM-A-R27-55A |
| <b>With servo motor and gear unit</b>                |                 |           |                |
| EMME-AS-40-...<br>EMGA-40-P-G...-EAS-40              | 40G             | 1456622   | EAMM-A-R27-40G |
| <b>With servo motor and right-angle gear unit</b>    |                 |           |                |
| EMME-AS-40-..., EMMB-AS-40-...<br>EMGA-40-A-G...-40P | 40G             | 1456622   | EAMM-A-R27-40G |
| <b>With stepper motor</b>                            |                 |           |                |
| EMMT-ST-57, EMMB-ST-57-...                           | 57A             | ★ 1133403 | EAMM-A-R27-57A |
| <b>With stepper motor and gear unit</b>              |                 |           |                |
| EMMT-ST-42, EMMB-ST-42-...<br>EMGA-40-P-G...-SST-42  | 40G             | 1456622   | EAMM-A-R27-40G |
| <b>ELGR-45, ELGG-45</b>                              |                 |           |                |
| <b>With servo motor</b>                              |                 |           |                |
| EMMT-AS-60-..., EMMB-AS-60-..., third-party motor    | 60P             | ★ 2224996 | EAMM-A-R38-60P |
| Third-party motor                                    | 70A             | 1133401   | EAMM-A-R38-70A |
| <b>With servo motor and gear unit</b>                |                 |           |                |
| EMME-AS-40-...<br>EMGA-40-P-G...-EAS-40              | 40G             | 1456623   | EAMM-A-R38-40G |
| EMMT-AS-60-...<br>EMGA-60-P-G...-EAS-60              | 60H             | 1456630   | EAMM-A-R38-60H |
| <b>With servo motor and right-angle gear unit</b>    |                 |           |                |
| EMME-AS-40-..., EMMB-AS-40-...<br>EMGA-40-A-G...-40P | 40G             | 1456623   | EAMM-A-R38-40G |
| EMMT-AS-60-..., EMMB-AS-60-...<br>EMGA-60-A-G...-60P | 60H             | 1456630   | EAMM-A-R38-60H |

## Product range overview

### Permissible axis/motor combinations with toothed belt axis ELGR, ELGG

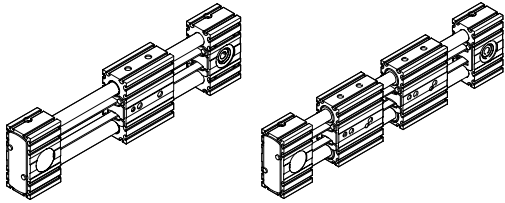

Table of interfaces for third-party motors

→ from page 64

Technical data for axial kits

→ from page 69

| Motor/gear unit <sup>1)</sup><br>Type                | Motor interface | Axial kit |                 |
|--|-----------------|-----------|-----------------|
|  |                 | Part no.  | Type            |
| <b>ELGR-45, ELGG-45</b>                              |                 |           |                 |
| <b>With stepper motor</b>                            |                 |           |                 |
| EMMT-ST-57, EMMB-ST-57-...                           | 57A             | ★ 1578138 | EAMM-A-R38-57A  |
| EMMT-ST-87, EMMB-ST-87-...                           | 87A             | ★ 1133404 | EAMM-A-R38-87A  |
| <b>With stepper motor and gear unit</b>              |                 |           |                 |
| EMMT-ST-42, EMMB-ST-42-...<br>EMGA-40-P-G...-SST-42  | 40G             | 1456623   | EAMM-A-R38-40G  |
| EMMT-ST-57, EMMB-ST-57-...<br>EMGA-60-P-G...-SST-57  | 60G             | 2310075   | EAMM-A-R38-60G  |
| <b>ELGR-55, ELGG-55</b>                              |                 |           |                 |
| <b>With servo motor</b>                              |                 |           |                 |
| <b>Third-party motor</b>                             |                 |           |                 |
| EMMT-AS-80-..., EMMB-AS-80-..., third-party motor    | 70A             | 1578139   | EAMM-A-R48-70A  |
| EMMT-AS-80-..., EMMB-AS-80-..., third-party motor    | 80P             | ★ 2225090 | EAMM-A-R48-80P  |
| EMMT-AS-100-..., third-party motor                   | 100A            | ★ 1133402 | EAMM-A-R48-100A |
| <b>With servo motor and gear unit</b>                |                 |           |                 |
| EMMT-AS-60-...<br>EMGA-60-P-G...-EAS-60              | 60H             | 1456633   | EAMM-A-R48-60H  |
| <b>With servo motor and right-angle gear unit</b>    |                 |           |                 |
| EMMT-AS-60-..., EMMB-AS-60-...<br>EMGA-60-A-G...-60P | 60H             | 1456633   | EAMM-A-R48-60H  |
| <b>With stepper motor</b>                            |                 |           |                 |
| EMMT-ST-87, EMMB-ST-87-...                           | 87A             | ★ 1133405 | EAMM-A-R48-87A  |
| <b>With stepper motor and gear unit</b>              |                 |           |                 |
| EMMT-ST-57, EMMB-ST-57-...<br>EMGA-60-P-G...-SST-57  | 60G             | 2374780   | EAMM-A-R48-60G  |

1) The input torque must not exceed the max. permissible transferable torque of the axial kit.

## Product range overview

## Permissible axis/motor combinations with rotary module ERMB, EHMB

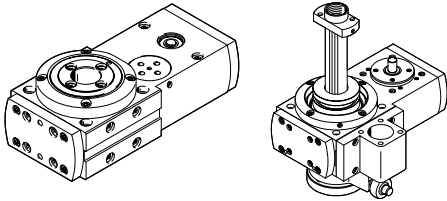

Table of interfaces for third-party motors

→ from page 64

Technical data for axial kits

→ from page 69

| Motor/gear unit <sup>1)</sup>                        | Motor interface | Axial kit |                    |
|--|-----------------|-----------|--------------------|
|  |                 | Part no.  | Type               |
| <b>ERMB-20, EHMB-20</b>                              |                 |           |                    |
| <b>With servo motor</b>                              |                 |           |                    |
| EMME-AS-40-..., EMMB-AS-40-...                       | 40P             | 2207441   | EAMM-A-D32-35A-40P |
| Third-party motor                                    | 40A             | 560281    | EAMM-A-D32-35A-40A |
| Third-party motor                                    | 40R             | 8105826   | EAMM-A-D32-40R     |
| Third-party motor                                    | 40RA            | 8125610   | EAMM-A-D32-40RA    |
| Third-party motor                                    | 55A             | 550979    | EAMM-A-D32-55A     |
| Third-party motor                                    | 58AA            | 8105884   | EAMM-A-D32-58AA    |
| EMMT-AS-60-..., EMMB-AS-60-..., third-party motor    | 60P             | 8197499   | EAMM-A-D32-60P-G2  |
| Third-party motor                                    | 60R             | 8105918   | EAMM-A-D32-60R     |
| Third-party motor                                    | 60RA            | 8105889   | EAMM-A-D32-60RA    |
| <b>With servo motor and gear unit</b>                |                 |           |                    |
| EMME-AS-40-...<br>EMGA-40-P-G...-EAS-40              | 40G             | 1454238   | EAMM-A-D32-40G     |
| EMMT-AS-60-...<br>EMGA-60-P-G...-EAS-60              | 60H             | 2946760   | EAMM-A-D32-60H     |
| <b>With servo motor and right-angle gear unit</b>    |                 |           |                    |
| EMME-AS-40-..., EMMB-AS-40-...<br>EMGA-40-A-G...-40P | 40G             | 1454238   | EAMM-A-D32-40G     |
| EMMT-AS-60-..., EMMB-AS-60-...<br>EMGA-60-A-G...-60P | 60H             | 2946760   | EAMM-A-D32-60H     |
| <b>With stepper motor</b>                            |                 |           |                    |
| EMMT-ST-42, EMMB-ST-42-..., third-party motor        | 42A             | ★ 543148  | EAMM-A-D32-42A     |
| EMMT-ST-57, EMMB-ST-57-...                           | 57A             | ★ 550980  | EAMM-A-D32-57A     |
| Third-party motor                                    | 60AA            | 8105887   | EAMM-A-D32-60AA    |
| <b>With stepper motor and gear unit</b>              |                 |           |                    |
| EMMT-ST-42, EMMB-ST-42-...<br>EMGA-40-P-G...-SST-42  | 40G             | 1454238   | EAMM-A-D32-40G     |
| EMMT-ST-57, EMMB-ST-57-...<br>EMGA-60-P-G...-SST-57  | 60G             | 2946758   | EAMM-A-D32-60G     |
| <b>With third-party gear unit</b>                    |                 |           |                    |
| Third-party gear unit                                | 50GA            | 8117072   | EAMM-A-D32-50GA    |

1) The input torque must not exceed the max. permissible transferable torque of the axial kit.

## Product range overview

### Permissible axis/motor combinations with rotary module ERMB, EHMB

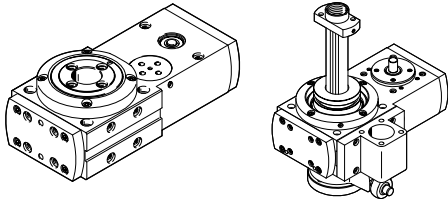

Table of interfaces for third-party motors

→ from page 64

Technical data for axial kits

→ from page 69

| Motor/gear unit <sup>1)</sup>                        | Motor interface | Axial kit |                                 |
|--|-----------------|-----------|---------------------------------|
|  |                 | Part no.  | Type                            |
| <b>ERMB-25, EHMB-25</b>                              |                 |           |                                 |
| <b>With servo motor</b>                              |                 |           |                                 |
| Third-party motor                                    | 55A             | 543153    | EAMM-A-D40-55A                  |
| Third-party motor                                    | 58AA            | 8105928   | EAMM-A-D40-58AA                 |
| EMMT-AS-60-..., EMMB-AS-60-..., third-party motor    | 60P             | 8197493   | EAMM-A-D40-60P-G2               |
| Third-party motor                                    | 60R             | 8117079   | EAMM-A-D40-60R                  |
| Third-party motor                                    | 60RA            | 8117078   | EAMM-A-D40-60RA                 |
| Third-party motor                                    | 70A             | 550981    | EAMM-A-D40-70A                  |
| Third-party motor                                    | 70AA, 70AB      | 8105952   | EAMM-A-D40-70AA                 |
| <b>With servo motor and gear unit</b>                |                 |           |                                 |
| EMME-AS-40-...<br>EMGA-40-P-G...-EAS-40              | 40G             | ★ 2256398 | EAMM-A-D40-40G-G2 <sup>2)</sup> |
| EMMT-AS-60-...<br>EMGA-60-P-G...-EAS-60              | 60H             | 1454242   | EAMM-A-D40-60H                  |
| <b>With servo motor and right-angle gear unit</b>    |                 |           |                                 |
| EMME-AS-40-..., EMMB-AS-40-...<br>EMGA-40-A-G...-40P | 40G             | ★ 2256398 | EAMM-A-D40-40G-G2 <sup>2)</sup> |
| EMMT-AS-60-..., EMMB-AS-60-...<br>EMGA-60-A-G...-60P | 60H             | 1454242   | EAMM-A-D40-60H                  |
| <b>With stepper motor</b>                            |                 |           |                                 |
| EMMT-ST-57, EMMB-ST-57-...                           | 57A             | ★ 543154  | EAMM-A-D40-57A                  |
| Third-party motor                                    | 60AA            | 8105929   | EAMM-A-D40-60AA                 |
| EMMT-ST-87, EMMB-ST-87-...                           | 87A             | ★ 550982  | EAMM-A-D40-87A                  |
| <b>With stepper motor and gear unit</b>              |                 |           |                                 |
| EMMT-ST-42, EMMB-ST-42-...<br>EMGA-40-P-G...-SST-42  | 40G             | ★ 2256398 | EAMM-A-D40-40G-G2 <sup>2)</sup> |
| EMMT-ST-57, EMMB-ST-57-...<br>EMGA-60-P-G...-SST-57  | 60G             | 2256400   | EAMM-A-D40-60G                  |
| <b>With third-party gear unit</b>                    |                 |           |                                 |
| Third-party gear unit                                | 40G             | ★ 2256398 | EAMM-A-D40-40G-G2 <sup>2)</sup> |
| Third-party gear unit                                | 50GA            | 8117076   | EAMM-A-D40-50GA                 |
| Third-party gear unit                                | 60H             | 1454242   | EAMM-A-D40-60H                  |

1) The input torque must not exceed the max. permissible transferable torque of the axial kit.

2) The axial kit can be retrofitted from IP40 to IP65 with the help of a seal set EADS-F → page 110

## Product range overview

## Permissible axis/motor combinations with rotary module ERMB, EHMB

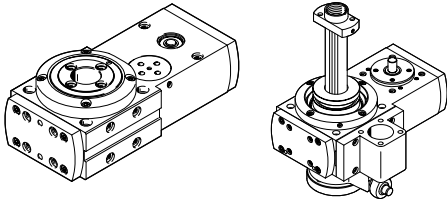

Table of interfaces for third-party motors

→ from page 64

Technical data for axial kits

→ from page 69

| Motor/gear unit <sup>1)</sup><br>Type                | Motor interface | Axial kit |                                 |
|--|-----------------|-----------|---------------------------------|
|  |                 | Part no.  | Type                            |
| <b>ERMB-32, EHMB-32</b>                              |                 |           |                                 |
| <b>With servo motor</b>                              |                 |           |                                 |
| Third-party motor                                    | 70A             | 543161    | EAMM-A-D60-70A                  |
| EMMT-AS-80-..., EMMB-AS-80-..., third-party motor    | 80P             | ★ 1977073 | EAMM-A-D60-80P                  |
| Third-party motor                                    | 80PB, 80R       | 8105937   | EAMM-A-D60-80PB                 |
| Third-party motor                                    | 84AA            | 8105945   | EAMM-A-D60-84AA                 |
| Third-party motor                                    | 92RA            | 8159834   | EAMM-A-D60-92RA                 |
| EMMT-AS-100-..., third-party motor                   | 100A            | 8197500   | EAMM-A-D60-100A-G2              |
| <b>With servo motor and gear unit</b>                |                 |           |                                 |
| EMMT-AS-60-...<br>EMGA-60-P-G...-EAS-60              | 60H             | 1454245   | EAMM-A-D60-60H                  |
| EMMT-AS-80-...<br>EMGA-80-P-G...-EAS-80              | 80G             | 8199480   | EAMM-A-D60-80G-G2               |
| EMMT-AS-100-...<br>EMGA-80-P-G...-SAS-100            | 80G             | 8199480   | EAMM-A-D60-80G-G2               |
| <b>With servo motor and right-angle gear unit</b>    |                 |           |                                 |
| EMMT-AS-60-..., EMMB-AS-60-...<br>EMGA-60-A-G...-60P | 60H             | 1454245   | EAMM-A-D60-60H                  |
| EMMT-AS-80-..., EMMB-AS-80-...<br>EMGA-80-A-G...-80P | 80G             | 8199480   | EAMM-A-D60-80G-G2               |
| EMMT-AS-100-...<br>EMGA-80-A-G...-100A               | 80G             | 8199480   | EAMM-A-D60-80G-G2               |
| <b>With stepper motor</b>                            |                 |           |                                 |
| EMMT-ST-87, EMMB-ST-87-...                           | 87A             | ★ 543162  | EAMM-A-D60-87A                  |
| <b>With stepper motor and gear unit</b>              |                 |           |                                 |
| EMMT-ST-57, EMMB-ST-57-...<br>EMGA-60-P-G...-SST-57  | 60G             | ★ 2256696 | EAMM-A-D60-60G-G2 <sup>3)</sup> |
| EMMT-ST-87, EMMB-ST-87-...<br>EMGA-80-P-G...-SST-87  | 80G             | 8199480   | EAMM-A-D60-80G-G2               |
| <b>With third-party gear unit</b>                    |                 |           |                                 |
| Third-party gear unit                                | 60H             | 1454245   | EAMM-A-D60-60H                  |
| Third-party gear unit                                | 80G             | 8199480   | EAMM-A-D60-80G-G2               |
| Third-party gear unit                                | 90GA            | 8105944   | EAMM-A-D60-90GA                 |

1) The input torque must not exceed the max. permissible transferable torque of the axial kit.

2) The axial kit can be retrofitted from IP40 to IP65 with the help of a seal set EADS-F → page 110.

## Product range overview

### Permissible axis/motor combinations with planar surface gantry EXCM

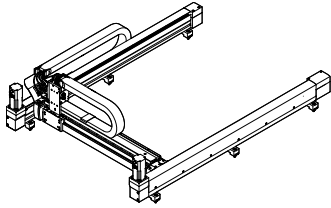

Technical data for axial kits  
→ from page 69

| Motor/gear unit <sup>1)</sup><br>Type | Motor interface | Axial kit |                |
|---------------------------------------|-----------------|-----------|----------------|
|                                       |                 | Part no.  | Type           |
| <b>EXCM-30</b>                        |                 |           |                |
| <b>With stepper motor</b>             |                 |           |                |
| EMMT-ST-42-..., EMMB-ST-42-...        | 42A             | 8210057   | EAMM-A-X22-42A |
| <b>EXCM-40</b>                        |                 |           |                |
| <b>With stepper motor</b>             |                 |           |                |
| EMMT-ST-57-..., EMMB-ST-57-...        | 57A             | 8165289   | EAMM-A-X48-57A |
| EMMT-ST-87-..., EMMB-ST-87-...        | 87A             | 8210061   | EAMM-A-X48-87A |

1) The input torque must not exceed the max. permissible transferable torque of the axial kit.

### Permissible axis/motor combinations with planar surface gantry EXCH

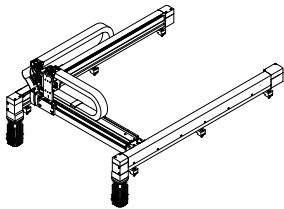

Technical data for axial kits  
→ from page 69

| Motor/gear unit <sup>1)</sup><br>Type | Motor interface | Axial kit |                 |
|---------------------------------------|-----------------|-----------|-----------------|
|                                       |                 | Part no.  | Type            |
| <b>EXCH-40</b>                        |                 |           |                 |
| <b>With servo motor</b>               |                 |           |                 |
| EMMT-AS-80-..., EMMB-AS-80-...        | 80P             | 8164654   | EAMM-A-X48-80P  |
| <b>EXCH-60</b>                        |                 |           |                 |
| <b>With servo motor</b>               |                 |           |                 |
| EMMT-AS-100-...                       | 100A            | 8164656   | EAMM-A-X62-100A |
| EMMT-AS-150-...                       | 150A            | 8164657   | EAMM-A-X62-150A |

1) The input torque must not exceed the max. permissible transferable torque of the axial kit.

## Product range overview

### Permissible axis/motor combinations with linear gantry EXCT

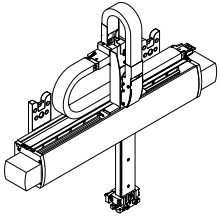

Technical data for axial kits  
→ from page 69

| Motor/gear unit <sup>1)</sup><br>Type | Motor interface | Axial kit |                           |
|---------------------------------------|-----------------|-----------|---------------------------|
|                                       |                 | Part no.  | Type                      |
| <b>EXCT-15</b>                        |                 |           |                           |
| <b>With servo motor</b>               |                 |           |                           |
| <b>EMMT-AS-80-..., EMMB-AS-80-...</b> | 80P             | ★ 8164277 | <b>EAMM-A-L48-80P-G2</b>  |
| <b>EXCT-30</b>                        |                 |           |                           |
| <b>With servo motor</b>               |                 |           |                           |
| <b>EMMT-AS-100-...</b>                | 100A            | 8164409   | <b>EAMM-A-Y62-100A</b>    |
| <b>EXCT-100</b>                       |                 |           |                           |
| <b>With servo motor</b>               |                 |           |                           |
| <b>EMMT-AS-100-...</b>                | 100A            | ★ 8164276 | <b>EAMM-A-L62-100A-G2</b> |

1) The input torque must not exceed the max. permissible transferable torque of the axial kit.

## Product range overview

| Third-party motors and gear units |                 |  |
|-----------------------------------|-----------------|--|
| Manufacturer                      | Motor interface | Type   |
| Allen-Bradley/Rockwell Automation | <b>40R</b>      | TL-A110; TL-A120; TL-A130; TLY-A110; TLY-A120; TLY-A130  |
| Allen-Bradley/Rockwell Automation | <b>55A</b>      | MPL-A/B1510; MPL-A/B1520; MPL-A/B1530; VPL-A/B-063x  |
| Allen-Bradley/Rockwell Automation | <b>60R</b>      | TL-A220; TL-A230; TLY-A220; TLY-A230   |
| Allen-Bradley/Rockwell Automation | <b>70A</b>      | MPL-A/B210; MPL-A/B220; MPL-A/B230; VPL-A/B-075x   |
| Allen-Bradley/Rockwell Automation | <b>80R</b>      | TLx-A25  |
| Allen-Bradley/Rockwell Automation | <b>90R</b>      | TLY-A310   |
| Allen-Bradley/Rockwell Automation | <b>92RA</b>     | MPF-B310; MPL-B320; MPL-B330; VPL-A/B1001; VPL-A/B1002; VPL-A/B1003  |
| Allen-Bradley/Rockwell Automation | <b>100A</b>     | VPL-A/B1152; VPL-A/B1153; MPL-A/B420; MPL-A/B430   |
| Allen-Bradley/Rockwell Automation | <b>108AA</b>    | VPL-A/B1303; VPL-A/B1304; VPL-A/B1306; MPL-A/B4530; MPL-A/B4540; MPL-A/B4560   |
| Allen-Bradley/Rockwell Automation | <b>190A</b>     | B640; B660; B690   |
| AMK                               | <b>55A</b>      | DT3  |
| AMK                               | <b>70A</b>      | DT4-1; DT4-2   |
| AMK                               | <b>100A</b>     | DT5-15; DT5-23; DT5-3; DT5-5; DT5-9; DTK5-3  |
| Apex Dynamics INC.                | <b>40G</b>      | PG040  |
| Apex Dynamics INC.                | <b>50GA</b>     | PE 050   |
| Apex Dynamics INC.                | <b>60H</b>      | PG II 060; PG060; PG2-060  |
| Apex Dynamics INC.                | <b>70GA</b>     | PE 070   |
| Apex Dynamics INC.                | <b>80G</b>      | PG080  |
| Apex Dynamics INC.                | <b>86GA</b>     | PG2-080; PG II 080   |
| Apex Dynamics INC.                | <b>90GA</b>     | PE 090   |
| Apex Dynamics INC.                | <b>114GA</b>    | PG II 120; PG2-120   |
| Apex Dynamics INC.                | <b>120G</b>     | PG120  |
| Apex Dynamics INC.                | <b>120GA</b>    | PG080A   |
| Apex Dynamics INC.                | <b>120GC</b>    | PE 120   |
| Apex Dynamics INC.                | <b>160G</b>     | PG160; PG II 160; PG2-160  |
| B+R Automation                    | <b>40G</b>      | 8GP30-040  |
| B+R Automation                    | <b>40R</b>      | 8LVA1  |
| B+R Automation                    | <b>55A</b>      | 8LSA2  |
| B+R Automation                    | <b>57AA</b>     | 80MPF  |
| B+R Automation                    | <b>58AA</b>     | 8JSA2  |
| B+R Automation                    | <b>60H</b>      | 8GP30-060; 8GP40-060   |
| B+R Automation                    | <b>60PA</b>     | 8LVA22; 8LVA23   |
| B+R Automation                    | <b>70AA</b>     | 8JSA3  |
| B+R Automation                    | <b>72GA</b>     | 8GP60-070  |
| B+R Automation                    | <b>80G</b>      | 8GP40-080  |
| B+R Automation                    | <b>80PA</b>     | 8LVA3  |
| B+R Automation                    | <b>84AA</b>     | 8JSA4  |
| B+R Automation                    | <b>88A</b>      | 8LSA3; 8MSA3   |
| B+R Automation                    | <b>100A</b>     | 8LSA4; 8MSA4; 8MSC4  |
| Baumüller                         | <b>55A</b>      | DSD 028 M; DSD 028 S   |
| Baumüller                         | <b>70A</b>      | DSD 036 M; DSD 036 S   |
| Baumüller                         | <b>88A</b>      | DS 045 L; DS 045 M; DS 045 S; DSC 045 K; DSC 045 M; DSC 045 S; DSCG 045 K; DSCG 045 M; DSCG 045 S; DSD 045 L; DSD 045 M; DSD 045 S |
| Baumüller                         | <b>126AA</b>    | DSC 056 K; DSC 056 M; DSC 056 S; DSCG 056 K; DSCG 056 M; DSCG 056 S; DSD 056 L; DSD 056 M; DSD 056 S                               |
| Beckhoff                          | <b>40R</b>      | AM3011; AM3012; AM3013; AM3111; AM3112; AM8111; AM8113   |
| Beckhoff                          | <b>42A</b>      | AS1010; AS1020   |
| Beckhoff                          | <b>55A</b>      | AM227LL; AM227M; AM8021; AM8022; AM8023; AM8121; AM8122  |
| Beckhoff                          | <b>58AA</b>     | AM3021; AM3022; AM3023; AM3024   |
| Beckhoff                          | <b>60RB</b>     | AM3121   |
| Beckhoff                          | <b>70AA</b>     | AM3031; AM3032; AM3033; AM8031; AM8032; AM8131; AM8531   |
| Beckhoff                          | <b>84AA</b>     | AM3041; AM3042; AM3043; AM3044; AM3541; AM3542; AM3543; AM8041; AM8042; AM8043   |
| Beckhoff                          | <b>88A</b>      | AM247L   |
| Beckhoff                          | <b>100A</b>     | AM257M; AM257S   |
| Beckhoff                          | <b>104AA</b>    | AM8051; AM8052; AM8053   |
| Beckhoff                          | <b>108AA</b>    | AM3051; AM3052; AM3053; AM3054; AM3551; AM3552; AM3553; AM8051-XXXX-900  |
| Beckhoff                          | <b>158AA</b>    | AM3062; AM3063; AM3064; AM3065; AM3562; AM3563; AM8061; AM8062; AM8063   |



## Product range overview

| Third-party motors and gear units |                 |   |
|-----------------------------------|-----------------|---|
| Manufacturer                      | Motor interface | Type  |
| Bosch Rexroth                     | <b>38AA</b>     | MSM019A; MSM019B  |
| Bosch Rexroth                     | <b>40G</b>      | GTE040  |
| Bosch Rexroth                     | <b>58AA</b>     | MKD 025; MSK030B; MSK030C; MS2N03-BXXXXN-AXDK0-NNNNN-NN; MS2N03-BXXXXN-BXDG0-NNNNN-NN; MS2N03-BXXXXN-BXDH1-NNNNE-NN; MS2N03-BXXXXN-CXDG0-NNNNN-NN; MS2N03-BXXXXN-CXDG1-NNNNN-NN; MS2N03-BXXXXN-CXDH0-NNNNN-NN; MS2N03-BXXXXN-CXDH1-NNNNN-NN; MS2N03-BXXXXN-CXSG1-NNNNN- |
| Bosch Rexroth                     | <b>60H</b>      | GTE060  |
| Bosch Rexroth                     | <b>60P</b>      | MSM 031C  |
| Bosch Rexroth                     | <b>60RA</b>     | MSM030B; MSM031B  |
| Bosch Rexroth                     | <b>68GA</b>     | GTM060  |
| Bosch Rexroth                     | <b>75GA</b>     | GTM075  |
| Bosch Rexroth                     | <b>80G</b>      | GTE080  |
| Bosch Rexroth                     | <b>80P</b>      | MSM040B; MSM041B  |
| Bosch Rexroth                     | <b>82AA</b>     | MKD041; MSK040B; MSK040C; MSK043C; MS2N04   |
| Bosch Rexroth                     | <b>100A</b>     | MSK050B; MSK050C  |
| Bosch Rexroth                     | <b>115GA</b>    | GTM100  |
| Bosch Rexroth                     | <b>116AA</b>    | MSK061B; MSK061C  |
| Bosch Rexroth                     | <b>120G</b>     | GTE120  |
| Bosch Rexroth                     | <b>158AA</b>    | MSK070C; MSK070D; MSK070E; MSK071C; MSK071D; MSK071E; MSK075C; MSK075D; MSK075E   |
| Bosch Rexroth                     | <b>160G</b>     | GTE160  |
| Danaher Motion                    | <b>40R</b>      | AKM1 AK; AKM1 AN  |
| Danaher Motion                    | <b>58AA</b>     | AKM21 AC; AKM21 AN; AKM22 AC; AKM22 AN; AKM23 AC; AKM23 AN; AKM24 AC; AKM24 AN; AKM2x AC/AN   |
| Danaher Motion                    | <b>60P</b>      | AKM2 CK   |
| Danaher Motion                    | <b>70AA</b>     | AKM 31 AC; AKM 31 AN; AKM 32 AC; AKM 32 AN; AKM 33 AC; AKM 33 AN  |
| Danaher Motion                    | <b>84AA</b>     | AKM 41 AC; AKM 41 AN; AKM 42 AC; AKM 42 AN; AKM 43 AC; AKM 43 AN; AKM 44 AC; AKM 44 AN  |
| Delta                             | <b>80RA</b>     | ECMA-C Δ0807  |
| Elau                              | <b>55A</b>      | SH-055 80 005; SH-055 80 009; SH-055 80 013   |
| Elau                              | <b>70A</b>      | iSH 070 60 011; iSH 070 60 017; SH-070 60 010; SH-070 60 020; SM-070 xx010; SM-070 xx020  |
| Elau                              | <b>70AA</b>     | iSH 070 60 022; SH-070 60 030   |
| Elau                              | <b>104AA</b>    | SH 100 30 100   |
| Esitron                           | <b>88A</b>      | esiMot 32/3   |
| Fanuc                             | <b>60PA</b>     | BETA iS1  |
| Fanuc                             | <b>88A</b>      | S 4/5000 HV   |
| Fastech                           | <b>20AC</b>     | EzM2-20   |
| Fastech                           | <b>25AA</b>     | EzM-25  |
| Fastech                           | <b>28AA</b>     | EzM2-28   |
| Fastech                           | <b>35A</b>      | EzM2-35   |
| Fastech                           | <b>42A</b>      | EzM2-42   |
| Fastech                           | <b>57A</b>      | EzM2-56   |
| Fastech                           | <b>60AA</b>     | EzM2-60   |
| Inovance                          | <b>40R</b>      | ISMH1-10B30   |
| Inovance                          | <b>60PA</b>     | ISMH1-20B30; ISMH1-40B30  |
| Inovance                          | <b>80PA</b>     | ISMH1-75B30   |
| Kollmorgen                        | <b>40R</b>      | AKM11; AKM12; AKM13   |
| Kollmorgen                        | <b>55A</b>      | DBL2 H00080   |
| Kollmorgen                        | <b>58AA</b>     | AKM21; AKM22; AKM23; AKM24  |
| Kollmorgen                        | <b>70AA</b>     | AKM31x-Ax; AKM32x-Ax; AKM33x-Ax   |
| Kollmorgen                        | <b>84AA</b>     | AKM41x-Ax; AKM42x-Ax; AKM43x-Ax; AKM44x-Ax  |
| Kollmorgen                        | <b>108AA</b>    | AKM51x-Ax; AKM52x-Ax; AKM53x-Ax; AKM54x-Ax  |
| Kollmorgen                        | <b>158AA</b>    | AKM62; AKM63; AKM64; AKM65  |
| Lenze                             | <b>68GA</b>     | GPA00; MPR050-1S GCN  |
| Lenze                             | <b>70A</b>      | MCS 06; MDSKSxx036  |
| Lenze                             | <b>75GA</b>     | GPA01   |
| Lenze                             | <b>88A</b>      | MCA 10 FF100; MCS 09; MDSKSxx056 FF100; LST-074-2   |
| Lenze                             | <b>115GA</b>    | GPA02   |
| Lenze                             | <b>120GA</b>    | GKR03-2M VAK; GKR04-2S VAK  |

## Product range overview

| Third-party motors and gear units |                 |   |
|-----------------------------------|-----------------|---|
| Manufacturer                      | Motor interface | Type  |
| Minebea                           | 20AA            | 08PM-K (IP20)   |
| Minebea                           | 25AA            | 10PM-K (IP20)   |
| Minebea                           | 35A             | 14PY-Z (IP20)   |
| Minebea                           | 42A             | 17PY-Z (IP20)   |
| Minebea                           | 57A             | 23KY-K (IP20)   |
| Minebea                           | 87AB            | 34KM-K (IP20)   |
| Mitsubishi                        | 28M             | HC-AQ0335D  |
| Mitsubishi                        | 40R             | HF-KE13; HF-KP053; HF-KP13; HF-MP053; HF-MP13; HG-MR13B                           |
| Mitsubishi                        | 60PA            | HF-KP23; HF-KP43; HK-KT23W; HK-KT43W; HF-KE23; HF-KE43; HF-MP23; HF-MP43; HG-KR43 |
| Mitsubishi                        | 80PA            | HG-KR73; HK-KT7M3W  |
| Moons                             | 20AB            | 8HYxx (IP20)  |
| Moons                             | 35AB            | MS14HA (IP20)   |
| Moons                             | 42A             | MS17HA (IP20)   |
| Moons                             | 57A             | MS23HA (IP20)   |
| Moons                             | 60PA            | SM601AE4; SM602AE4  |
| Moons                             | 80PA            | SM803AE4  |
| Moons                             | 87AA            | ML34HD (IP20)   |
| Nanotec                           | 42A             | ST4209  |
| Nanotec                           | 57AA            | ST6018  |
| Nanotec                           | 87AB            | ST8918L   |
| Neugart                           | 40G             | PLE 040; WPLE 40  |
| Neugart                           | 50GA            | PLPE 50; WPLPE 50   |
| Neugart                           | 60H             | PLE 060; WPLE 60  |
| Neugart                           | 68GA            | PLN 70; WPLN 70   |
| Neugart                           | 70GA            | PLPE 70; WPLPE 70   |
| Neugart                           | 72GA            | PLN 70 (OP14); WPLN 70 (OP14)   |
| Neugart                           | 75GA            | PLN 90; WPLN 90   |
| Neugart                           | 80G             | PLE 080; WPLE 80  |
| Neugart                           | 90GA            | PLPE 90; WPLPE 90   |
| Neugart                           | 115GA           | PLN 115; WPLN 115   |
| Neugart                           | 120G            | PLE 120; WPLE 120   |
| Neugart                           | 120GA           | PLE 080-90; WPLE 80-90  |
| Neugart                           | 120GC           | PLPE 120; WPLPE 120   |
| Neugart                           | 160G            | PLE 160   |
| Omron                             | 40R             | R7M-A10030; R88M-K10030H; SGMAV-01A; SGMAV-A5A; SGMAV-C2A; SGMJV-01A; SGMJV-05A   |
| Omron                             | 60P             | R88M-1M40030  |
| Omron                             | 60PA            | SGMAH-02; SGMAV-02A; SGMAV-04A; SGMAV-06A; SGMJV-02A; SGMJV-04A                   |
| Omron                             | 60RA            | R88M-1M20030; R88M-G20030H; R88M-K20030H-S2                                       |
| Omron                             | 80P             | R88M-1M75030; R88M-G75030H; R88M-K75030   |
| Oriental Motor                    | 20AA            | CVK21   |
| Oriental Motor                    | 28AA            | AR2x; AZ2x; CVK22   |
| Oriental Motor                    | 35AA            | CVK23   |
| Oriental Motor                    | 42AA            | CVK24   |
| Oriental Motor                    | 42AB            | AR4x; AZ4x  |
| Oriental Motor                    | 57A             | PKP26   |
| Oriental Motor                    | 57AD            | CVK26   |
| Oriental Motor                    | 60AB            | AR6x; AZ6x  |
| Oriental Motor                    | 85AA            | AR9x; AZ9x  |
| Panasonic                         | 38AA            | MSMD012J1; MSMF012; MSMF5A  |
| Panasonic                         | 60P             | MSMF042   |
| Panasonic                         | 60RA            | MSMF022   |
| Panasonic                         | 80P             | MSMF082   |
| Parker                            | 120GA           | PE 4  |
| Parker                            | 55A             | SMH60601_45112ID654   |
| Parker                            | 60H             | PE 3  |
| Parker                            | 70A             | SMHA60301   |
| Planetroll                        | 115GA           | PDH 200/1   |
| Planetroll                        | 68GA            | PDH 25/1  |
| Planetroll                        | 75GA            | PDH 100/1   |

## Product range overview

| Third-party motors and gear units |                 |   |
|-----------------------------------|-----------------|---|
| Manufacturer                      | Motor interface | Type  |
| Sanyo Denki                       | <b>28AA</b>     | SH2281; SH2285  |
| Sanyo Denki                       | <b>35A</b>      | SH3533; SH3537  |
| Sanyo Denki                       | <b>40R</b>      | R2EA04008; R2xA04005  |
| Sanyo Denki                       | <b>40S</b>      | R2AA04003   |
| Sanyo Denki                       | <b>40T</b>      | R2AA04005; R2AA04010  |
| Sanyo Denki                       | <b>60PA</b>     | R2AA06040; R2AA06040FX; R2xA06020   |
| Sanyo Denki                       | <b>60S</b>      | R2AA06010   |
| Sanyo Denki                       | <b>60T</b>      | R2AA06020   |
| Sanyo Denki                       | <b>80PB</b>     | R2AA08075   |
| Sanyo Denki                       | <b>90R</b>      | R2AAB8100   |
| Schneider Electric                | <b>40A</b>      | BMH 1403  |
| Schneider Electric                | <b>42A</b>      | ILP2R421; ILP2R422; ILP2R423  |
| Schneider Electric                | <b>55A</b>      | BMH 055; BSH 055  |
| Schneider Electric                | <b>57AA</b>     | NEMA23; NEMA24  |
| Schneider Electric                | <b>57AB</b>     | BRS 364; BRS 366; IFS 61; IFS 62; ILS1x571; ILS1x572  |
| Schneider Electric                | <b>57AC</b>     | BRS 368; IFS 63; ILS1x573   |
| Schneider Electric                | <b>70A</b>      | BMH 0701; BMH 0702; BSH 0701; BSH 0702  |
| Schneider Electric                | <b>70AA</b>     | BMH 0703; BSH 0703  |
| Schneider Electric                | <b>80G</b>      | GBX080  |
| Schneider Electric                | <b>104AA</b>    | BSH 1004  |
| Schneider Electric                | <b>116AA</b>    | BRH 110   |
| Schneider Electric                | <b>120G</b>     | GBX120  |
| SEW Eurodrive                     | <b>56GA</b>     | PSF 121; PSF 122; PSKF 121; PSKF 122  |
| SEW Eurodrive                     | <b>58AA</b>     | CMP40   |
| SEW Eurodrive                     | <b>68GA</b>     | PSC 221; PSC 222; PSF 221; PSF 222; PSKC 221; PSKC 222; PSKF 221; PSKF 222  |
| SEW Eurodrive                     | <b>70A</b>      | CMP50   |
| SEW Eurodrive                     | <b>70GA</b>     | PSCZ 221; PSCZ 222; PSKCZ 221; PSKCZ 222  |
| SEW Eurodrive                     | <b>75GA</b>     | PSC 321; PSC 322; PSF 321; PSF 322; PSKC 321; PSKC 322; PSKF 321; PSKF 322  |
| SEW Eurodrive                     | <b>88A</b>      | CMP63   |
| SEW Eurodrive                     | <b>92RA</b>     | WF10 Ø120; WF10DT56   |
| SEW Eurodrive                     | <b>100A</b>     | CFM71   |
| SEW Eurodrive                     | <b>115GA</b>    | PSC 521; PSC 522; PSF 521; PSF 522; PSKC 521; PSKC 522; PSKF 521; PSKF 522  |
| SEW Eurodrive                     | <b>120GA</b>    | RF07 Ø120; SF37 Ø120; WF30 Ø120; WF37 Ø120  |
| SEW Eurodrive                     | <b>120GB</b>    | RF27 Ø120   |
| SEW Eurodrive                     | <b>126AA</b>    | CMPZ71  |
| SEW Eurodrive                     | <b>190A</b>     | CFM112  |
| Siemens                           | <b>40R</b>      | 1FK2102-0AG...; 1FK2102-1AG...  |
| Siemens                           | <b>40RA</b>     | 1FK7011; 1FK7015  |
| Siemens                           | <b>55A</b>      | 1FK7022; 1FT6021; 1FT6024   |
| Siemens                           | <b>60PA</b>     | 1FK2103-2AG...-0...; 1FK2103-2AG...-1...; 1FK2103-4AG...-0...; 1FK2103-4AG...-1...; 1FK2203-2AG...-0...; 1FK2203-2AG...-1...; 1FK2203-4AG...-0...; 1FK2203-4AG...-1...; 1FL603x-2AF21 |
| Siemens                           | <b>60RB</b>     | 1FK2103-2AG...-2...; 1FK2103-4AG...-2...; 1FK2203-2AG...-2...; 1FK2203-4AG...-2...  |
| Siemens                           | <b>68GA</b>     | SP 060S   |
| Siemens                           | <b>70AA</b>     | 1FT6031; 1FT6034  |
| Siemens                           | <b>70AB</b>     | 1FK7032; 1FK7033; 1FK7034; 1FT7034; 6SN2155...  |
| Siemens                           | <b>75GA</b>     | SP 075S   |
| Siemens                           | <b>80PA</b>     | 1FK2104-4AK...; 1FK2104-5AK...; 1FL604x-2AF21   |
| Siemens                           | <b>80RA</b>     | 1FL604x-2AF21   |
| Siemens                           | <b>84AA</b>     | 1FK7040; 1FK7042; 1FK7043; 1FK7044; 1FT6041; 1FT6044; 1FT704x   |
| Siemens                           | <b>96RB</b>     | 1FT7042; 1FT7044; 1FT7046   |
| Siemens                           | <b>115GA</b>    | SP 100S   |
| Siemens                           | <b>120GA</b>    | BF29-KQ-703   |
| Siemens                           | <b>120GB</b>    | ZF29-KQ-704; ZF29-KQ-706  |
| Siemens                           | <b>126AA</b>    | 1FK7060; 1FK7062; 1FK7063; 1FT6061; 1FT6062; 1FT6064; 1FT7062; 1FT7064; 1FT7066; 1FT7068; 1FK2206   |
| Siemens                           | <b>158AA</b>    | 1FK7080; 1FK7083; 1FK7086; 1FT6081; 1FT6082; 1FT6084; 1FT6086   |

## Product range overview

| Third-party motors and gear units |                 |   |
|-----------------------------------|-----------------|---|
| Manufacturer                      | Motor interface | Type  |
| Wittenstein Alpha                 | <b>40G</b>      | CP 005; CPK 005; alphira CP 040   |
| Wittenstein Alpha                 | <b>50GA</b>     | NPK 005; LP+ 050 (replaced by NP 005); LPK+ 050 (replaced by NPK 005); LK+ 050; LP+ 050; LPK+ 050; NP 005 |
| Wittenstein Alpha                 | <b>60H</b>      | CP 015; CPK 015; alphira CP 060   |
| Wittenstein Alpha                 | <b>68GA</b>     | SK+ 060; SP+ 060; SPC+ 060; SK+ 060 MF; SP+ 060 MF  |
| Wittenstein Alpha                 | <b>70GA</b>     | NP 015; NPK 015; LP+ 070 (replaced by NP 015); LPK+ 070 (replaced by NPK 015); LK+ 070; LP+ 070; LPK+ 070 |
| Wittenstein Alpha                 | <b>75GA</b>     | SK+ 075; SP+ 075; SPK+ 075; SPC+ 075; SK+ 075 MF; SP+ 075 MC; SP+ 075 MF; SPK+ 075 MF                     |
| Wittenstein Alpha                 | <b>80G</b>      | CP 025; CPK 025; alphira CP 080   |
| Wittenstein Alpha                 | <b>90GA</b>     | NP 025; NPK 025; LP+ 090 (replaced by NP 025); LPK+ 090 (replaced by NPK 025); LK+ 090; LP+ 090; LPK+ 090 |
| Wittenstein Alpha                 | <b>115GA</b>    | SK+ 100; SP+ 100; SPK+ 100; SPC+ 100; SK+ 100 MF; SP+ 100 MC; SP+ 100 MF; SPK+ 100 MF                     |
| Wittenstein Alpha                 | <b>120G</b>     | CP 035; CPK 035; alphira CP 115   |
| Wittenstein Alpha                 | <b>120GC</b>    | NP 035; NPK 035; LP+ 120 (replaced by NP 035); LPK+ 120 (replaced by NPK 035); LK+ 120; LP+ 120; LPK+ 120 |
| YASKAWA                           | <b>25A</b>      | SGMM...   |
| YASKAWA                           | <b>40R</b>      | SGM7J-A5A.A2.; SGM7J-01A.A2.; SGM7J-C2A.A2.; SGM7JA-A5A.A2.; SGM7JA-01A.A2.; SGM7JA-C2A.A2.               |
| YASKAWA                           | <b>60PA</b>     | SGM7J-02A.A2.; SGM7J-04A.A2.; SGM7J-06A.A2.   |
| YASKAWA                           | <b>60S</b>      | SGM7P-01A..2.   |
| YASKAWA                           | <b>80PA</b>     | SGM7J-08A.A2.   |

## Datasheet

### Material:

Coupling housing, coupling hubs,

motor flange: Aluminium

Screws: Galvanised steel

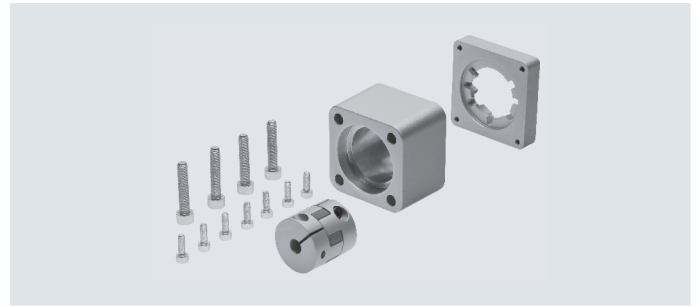

| General technical data |                        |                          |   |                  |            |        |
|------------------------|------------------------|--------------------------|---|------------------|------------|--------|
| Type                   | For axis               | Transferable torque [Nm] | Mass moment of inertia [kgmm <sup>2</sup> ] | Max. speed [rpm] | Weight [g] | → Page |
| EAMM-A-D19-28A         | EGSL                   | 1.1                      | 0.28  | 10000            | 80         | 78     |
| EAMM-A-D19-38AA        | EGSL                   | 1.1                      | 0.28  | 10000            | 121        |        |
| EAMM-A-D19-40A         | EGSL                   | 1.1                      | 0.28  | 10000            | 110        |        |
| EAMM-A-D19-40P         | EGSL                   | 1.1                      | 0.28  | 10000            | 110        |        |
| EAMM-A-D19-40R         | EGSL                   | 1.1                      | 0.28  | 10000            | 133        |        |
| EAMM-A-D19-42A         | EGSL                   | 1.1                      | 0.28  | 10000            | 130        |        |
| EAMM-A-D32-40A(-S1)    | EGSL, ESBF             | 1.1                      | 0.28  | 10000            | 130        |        |
| EAMM-A-D32-40G(-S1)    | EGSL, EHMB, ERMB, ESBF | 6.5                      | 5.87  | 8000             | 420        |        |
| EAMM-A-D32-40P(-S1)    | EGSL, ESBF             | 1.1                      | 0.28  | 10000            | 160        |        |
| EAMM-A-D32-40R         | EGSL, ESBF             | 6.5                      | 5.87  | 8000             | 309        |        |
| EAMM-A-D32-40RA        | EGSL, ESBF             | 6.5                      | 5.87  | 8000             | 309        |        |
| EAMM-A-D32-35A-40A     | EHMB, ERMB             | 4                        | 5.87  | 8000             | 220        |        |
| EAMM-A-D32-35A-40P     | EHMB, ERMB             | 4                        | 5.87  | 8000             | 160        |        |
| EAMM-A-D32-42A(-S1)    | EGSL, EHMB, ERMB, ESBF | 1.1                      | 0.28  | 10000            | 140        |        |
| EAMM-A-D32-50GA        | EGSL, EHMB, ERMB, ESBF | 6.5                      | 5.87  | 8000             | 446        |        |
| EAMM-A-D32-55A(-S1)    | EGSL, EHMB, ERMB, ESBF | 4                        | 5.87  | 8000             | 260        |        |
| EAMM-A-D32-58AA        | EGSL, EHMB, ERMB, ESBF | 6.5                      | 5.87  | 8000             | 329        |        |
| EAMM-A-D32-60AA        | EGSL, EHMB, ERMB, ESBF | 6.5                      | 5.87  | 8000             | 341        |        |
| EAMM-A-D32-57A(-S1)    | EGSL, EHMB, ERMB, ESBF | 4                        | 5.87  | 8000             | 270        |        |
| EAMM-A-D32-60G(-S1)    | EGSL, EHMB, ERMB, ESBF | 6.5                      | 5.87  | 8000             | 540        |        |
| EAMM-A-D32-60H(-S1)    | EGSL, EHMB, ERMB, ESBF | 6.5                      | 5.87  | 8000             | 540        |        |
| EAMM-A-D32-60P(-S1)-G2 | EGSL, EHMB, ERMB, ESBF | 6.5                      | 5.87  | 8000             | 380        |        |
| EAMM-A-D32-60R         | EGSL, EHMB, ERMB, ESBF | 6.5                      | 5.87  | 8000             | 386        |        |
| EAMM-A-D32-60RA        | EGSL, EHMB, ERMB, ESBF | 6.5                      | 5.87  | 8000             | 420        |        |
| EAMM-A-D40-40G(-S1)-G2 | EGSL, EHMB, ERMB, ESBF | 8                        | 5.87  | 8000             | 450        |        |
| EAMM-A-D40-50GA        | EGSL, EHMB, ERMB, ESBF | 12.5                     | 5.87  | 8000             | 438        |        |
| EAMM-A-D40-55A(-S1)    | EGSL, EHMB, ERMB, ESBF | 8                        | 5.87  | 8000             | 350        |        |
| EAMM-A-D40-57A(-S1)    | EGSL, EHMB, ERMB, ESBF | 6                        | 5.87  | 8000             | 350        |        |
| EAMM-A-D40-58AA        | EGSL, EHMB, ERMB, ESBF | 12.5                     | 5.87  | 8000             | 354        |        |
| EAMM-A-D40-60AA        | EGSL, EHMB, ERMB, ESBF | 12.5                     | 5.87  | 8000             | 363        |        |
| EAMM-A-D40-60G(-S1)    | EGSL, EHMB, ERMB, ESBF | 12.5                     | 5.87  | 8000             | 570        |        |
| EAMM-A-D40-60H(-S1)    | EGSL, EHMB, ERMB, ESBF | 12.5                     | 5.87  | 8000             | 570        |        |
| EAMM-A-D40-60P(-S1)-G2 | EGSL, EHMB, ERMB, ESBF | 12.5                     | 5.87  | 8000             | 340        |        |
| EAMM-A-D40-60R         | EGSL, EHMB, ERMB, ESBF | 12.5                     | 5.87  | 8000             | 368        |        |
| EAMM-A-D40-60RA        | EGSL, EHMB, ERMB, ESBF | 12.5                     | 5.87  | 8000             | 336        |        |
| EAMM-A-D40-70AA        | EGSL, EHMB, ERMB, ESBF | 12.5                     | 5.87  | 8000             | 443        |        |
| EAMM-A-D40-70A(-S1)    | EGSL, EHMB, ERMB, ESBF | 8                        | 5.87  | 8000             | 410        |        |
| EAMM-A-D40-87A(-S1)    | EGSL, EHMB, ERMB, ESBF | 8                        | 5.87  | 8000             | 530        |        |
| EAMM-A-D50-60G(-S1)-G2 | ESBF                   | 21                       | 34.8  | 6000             | 950        |        |
| EAMM-A-D50-60H(-S1)-G2 | ESBF                   | 21                       | 34.8  | 6000             | 950        |        |
| EAMM-A-D50-70A(-S1)    | ESBF                   | 12                       | 34.8  | 6000             | 740        |        |
| EAMM-A-D50-70GA        | ESBF                   | 17                       | 34.8  | 6000             | 1018       |        |
| EAMM-A-D50-80G(-S1)    | ESBF                   | 17                       | 34.8  | 6000             | 1190       |        |

## Datasheet

| General technical data  |                        |                          |   |                  |            |        |    |
|-------------------------|------------------------|--------------------------|---|------------------|------------|--------|----|
| Type                    | For axis               | Transferable torque [Nm] | Mass moment of inertia [kgmm <sup>2</sup> ] | Max. speed [rpm] | Weight [g] | → Page |    |
| EAMM-A-D50-80P(-S1)-G2  | ESBF                   | 21                       | 34.8  | 6000             | 810        | 78     |    |
| EAMM-A-D50-80PB(-S1)-G2 | ESBF                   | 21                       | 34.8  | 6000             | 810        |        |    |
| EAMM-A-D50-82AA         | ESBF                   | 17                       | 34.8  | 6000             | 815        |        |    |
| EAMM-A-D50-84AA         | ESBF                   | 17                       | 34.8  | 6000             | 1012       |        |    |
| EAMM-A-D50-87A(-S1)     | ESBF                   | 17                       | 34.8  | 6000             | 860        |        |    |
| EAMM-A-D50-100A(-S1)    | ESBF                   | 17                       | 34.8  | 6000             | 1140       |        |    |
| EAMM-A-D60-60G(-S1)-G2  | EGSL, EHMB, ERMB, ESBF | 17                       | 34.8  | 6000             | 1350       |        |    |
| EAMM-A-D60-60H(-S1)     | EGSL, EHMB, ERMB, ESBF | 17                       | 34.8  | 6000             | 1250       |        |    |
| EAMM-A-D60-70A(-S1)     | EGSL, EHMB, ERMB, ESBF | 17                       | 34.8  | 6000             | 750        |        |    |
| EAMM-A-D60-80G(-S1)-G2  | EGSL, EHMB, ERMB, ESBF | 21                       | 34.8  | 6000             | 1500       |        |    |
| EAMM-A-D60-80P(-S1)     | EGSL, EHMB, ERMB, ESBF | 17                       | 34.8  | 6000             | 1040       |        |    |
| EAMM-A-D60-80PB         | EGSL, EHMB, ERMB, ESBF | 21                       | 34.8  | 6000             | 1041       |        |    |
| EAMM-A-D60-84AA         | EGSL, EHMB, ERMB, ESBF | 21                       | 34.8  | 6000             | 1173       |        |    |
| EAMM-A-D60-87A(-S1)     | EGSL, EHMB, ERMB, ESBF | 17                       | 34.8  | 6000             | 890        |        |    |
| EAMM-A-D60-90GA         | EGSL, EHMB, ERMB, ESBF | 21                       | 34.8  | 6000             | 2192       |        |    |
| EAMM-A-D60-92RA         | EGSL, EHMB, ERMB, ESBF | 21                       | 34.8  | 6000             | 1076       |        |    |
| EAMM-A-D60-100A(-S1)-G2 | EGSL, EHMB, ERMB, ESBF | 21                       | 34.8  | 6000             | 1310       |        |    |
| EAMM-A-D80-80G(-S1)     | ESBF                   | 60                       | 128   | 5500             | 1990       |        |    |
| EAMM-A-D80-84AA         | ESBF                   | 60                       | 128   | 5500             | 1843       |        |    |
| EAMM-A-D80-90GA         | ESBF                   | 60                       | 128   | 550              | 2192       |        |    |
| EAMM-A-D80-100A(-S1)    | ESBF                   | 60                       | 128   | 5500             | 2030       |        |    |
| EAMM-A-D80-150A(-S1)    | ESBF                   | 60                       | 128   | 5500             | 3070       |        |    |
| EAMM-A-D100-100A(-S1)   | ESBF                   | 60                       | 128   | 5500             | 2450       |        |    |
| EAMM-A-D100-120G(-S1)   | ESBF                   | 143                      | 280   | 4500             | 3520       |        |    |
| EAMM-A-D100-150A(-S1)   | ESBF                   | 143                      | 280   | 4500             | 3440       |        |    |
| EAMM-A-L27-40G          | EGC-TB                 | 2                        | 0.445                                       | 10000            | 180        |        | 88 |
| EAMM-A-L27-55A          | EGC-TB                 | 2                        | 0.445                                       | 10000            | 220        |        |    |
| EAMM-A-L27-57A          | EGC-TB                 | 1.6                      | 0.355                                       | 10000            | 180        |        |    |
| EAMM-A-L27-40A          | EGC-TB                 | 1.5                      | 0.355                                       | 10000            | 82         |        |    |
| EAMM-A-L27-40R          | EGC-TB                 | 1.6                      | 0.355                                       | 10000            | 110        |        |    |
| EAMM-A-L27-40RA         | EGC-TB                 | 1.6                      | 0.355                                       | 10000            | 84         |        |    |
| EAMM-A-L27-42A          | EGC-TB                 | 1.2                      | 0.45  | 10000            | 157        |        |    |
| EAMM-A-L27-58AA         | EGC-TB                 | 2                        | 0.355                                       | 10000            | 165        |        |    |
| EAMM-A-L27-57AA         | EGC-TB                 | 1.6                      | 0.355                                       | 10000            | 184        |        |    |
| EAMM-A-L27-57AB         | EGC-TB                 | 1.6                      | 0.355                                       | 10000            | 184        |        |    |
| EAMM-A-L27-57AC         | EGC-TB                 | 1.6                      | 0.45  | 10000            | 183        |        |    |
| EAMM-A-L27-60RA         | EGC-TB                 | 2                        | 0.45  | 10000            | 278        |        |    |
| EAMM-A-L27-60RB         | EGC-TB                 | 2                        | 0.45  | 10000            | 221        |        |    |
| EAMM-A-L27-50GA         | EGC-TB                 | 2                        | 0.45  | 10000            | 197        |        |    |
| EAMM-A-L27-60G          | EGC-TB                 | 2                        | 0.45  | 10000            | 307        |        |    |
| EAMM-A-L38-55A          | EGC-TB, ELGD-TB        | 4.4                      | 0.445                                       | 8000             | 210        |        |    |
| EAMM-A-L38-57A-G2       | EGC-TB, ELGD-TB        | 3.6                      | 3.2   | 8000             | 171        |        |    |
| EAMM-A-L38-60AA         | EGC-TB, ELGD-TB        | 8                        | 3.2   | 8000             | 231        |        |    |
| EAMM-A-L38-60G-G2       | EGC-TB, ELGD-TB        | 4.4                      | 3.2   | 8000             | 314        |        |    |
| EAMM-A-L38-60H-G2       | EGC-TB, ELGD-TB        | 4.4                      | 3.5   | 8000             | 315        |        |    |
| EAMM-A-L38-60P-G2       | EGC-TB, ELGD-TB        | 4.4                      | 3.2   | 8000             | 255        |        |    |
| EAMM-A-L38-60R-G2       | EGC-TB, ELGD-TB        | 4.4                      | 3.2   | 8000             | 254        |        |    |
| EAMM-A-L38-70A          | EGC-TB, ELGD-TB        | 4.4                      | 3.2   | 8000             | 290        |        |    |
| EAMM-A-L38-87A-G2       | EGC-TB, ELGD-TB        | 4.4                      | 3.2   | 8000             | 390        |        |    |
| EAMM-A-L38-58AA         | EGC-TB, ELGD-TB        | 9                        | 3.2   | 8000             | 208        |        |    |

## Datasheet

| General technical data |                 |                          |   |                  |            |        |
|------------------------|-----------------|--------------------------|---|------------------|------------|--------|
| Type                   | For axis        | Transferable torque [Nm] | Mass moment of inertia [kgmm <sup>2</sup> ] | Max. speed [rpm] | Weight [g] | → Page |
| EAMM-A-L38-57AA        | EGC-TB, ELGD-TB | 8                        | 3.2   | 8000             | 221        | 88     |
| EAMM-A-L38-60PA        | EGC-TB, ELGD-TB | 9                        | 3.3   | 8000             | 301        |        |
| EAMM-A-L38-60RA        | EGC-TB, ELGD-TB | 4.4                      | 3.2   | 8000             | 254        |        |
| EAMM-A-L38-60RB        | EGC-TB, ELGD-TB | 9                        | 3.2   | 8000             | 253        |        |
| EAMM-A-L38-70AA        | EGC-TB, ELGD-TB | 9                        | 3.3   | 8000             | 357        |        |
| EAMM-A-L38-88A         | EGC-TB, ELGD-TB | 9                        | 3.3   | 8000             | 508        |        |
| EAMM-A-L38-84AA        | EGC-TB, ELGD-TB | 9                        | 4.6   | 8000             | 712        |        |
| EAMM-A-L38-40G-G2      | EGC-TB, ELGD-TB | 4.4                      | 3.2   | 8000             | 228        |        |
| EAMM-A-L38-50GA        | EGC-TB, ELGD-TB | 9                        | 3.2   | 8000             | 245        |        |
| EAMM-A-L38-56GA        | EGC-TB, ELGD-TB | 9                        | 3.3   | 8000             | 275        |        |
| EAMM-A-L38-70GA-G2     | EGC-TB, ELGD-TB | 4.4                      | 4   | 8000             | 598        |        |
| EAMM-A-L38-67GA        | EGC-TB, ELGD-TB | 9                        | 4   | 8000             | 363        |        |
| EAMM-A-L38-72GA        | EGC-TB, ELGD-TB | 9                        | 4   | 8000             | 480        |        |
| EAMM-A-L48-60G-G2      | EGC-TB, ELGD-TB | 21                       | 39  | 6000             | 406        |        |
| EAMM-A-L48-60H-G2      | EGC-TB, ELGD-TB | 21                       | 39  | 6000             | 403        |        |
| EAMM-A-L48-60P         | EGC-TB, ELGD-TB | 12.5                     | 14.5  | 8000             | 279        |        |
| EAMM-A-L48-70A         | EGC-TB, ELGD-TB | 12.5                     | 14.5  | 8000             | 350        |        |
| EAMM-A-L48-80P-G2      | EGC-TB, ELGD-TB | 17                       | 39  | 6000             | 557        |        |
| EAMM-A-L48-87A-G2      | EGC-TB, ELGD-TB | 17                       | 39  | 6000             | 459        |        |
| EAMM-A-L48-100A-G2     | EGC-TB, ELGD-TB | 17                       | 39  | 6000             | 789        |        |
| EAMM-A-L48-55A         | EGC-TB, ELGD-TB | 12.5                     | 14.5  | 8000             | 352        |        |
| EAMM-A-L48-60PA        | EGC-TB, ELGD-TB | 12.5                     | 14.5  | 8000             | 454        |        |
| EAMM-A-L48-70AA        | EGC-TB, ELGD-TB | 12.5                     | 14.5  | 8000             | 498        |        |
| EAMM-A-L48-80PB        | EGC-TB, ELGD-TB | 17                       | 39  | 8000             | 560        |        |
| EAMM-A-L48-82AA        | EGC-TB, ELGD-TB | 12.5                     | 14.5  | 8000             | 613        |        |
| EAMM-A-L48-88A         | EGC-TB, ELGD-TB | 12.5                     | 14.5  | 8000             | 639        |        |
| EAMM-A-L48-90R         | EGC-TB, ELGD-TB | 12.5                     | 14.5  | 8000             | 741        |        |
| EAMM-A-L48-92RA        | EGC-TB, ELGD-TB | 12.5                     | 14.5  | 8000             | 827        |        |
| EAMM-A-L48-84AA        | EGC-TB, ELGD-TB | 17                       | 39  | 6000             | 925        |        |
| EAMM-A-L48-40G         | EGC-TB, ELGD-TB | 12.5                     | 14.5  | 8000             | 405        |        |
| EAMM-A-L48-50GA-G2     | EGC-TB, ELGD-TB | 21                       | 39  | 6000             | 415        |        |
| EAMM-A-L48-56GA        | EGC-TB, ELGD-TB | 12.5                     | 14.5  | 8000             | 430        |        |
| EAMM-A-L48-70GA-G2     | EGC-TB, ELGD-TB | 21                       | 39  | 6000             | 725        |        |
| EAMM-A-L48-75GA        | EGC-TB, ELGD-TB | 17                       | 39  | 6000             | 704        |        |
| EAMM-A-L48-80G-G2      | EGC-TB, ELGD-TB | 21                       | 39  | 6000             | 619        |        |
| EAMM-A-L48-68GA        | EGC-TB, ELGD-TB | 12.5                     | 14.5  | 8000             | 542        |        |
| EAMM-A-L48-72GA        | EGC-TB, ELGD-TB | 12.5                     | 14.5  | 8000             | 623        |        |
| EAMM-A-L48-90GA        | EGC-TB, ELGD-TB | 17                       | 39  | 6000             | 675        |        |
| EAMM-A-L48-120GA       | EGC-TB, ELGD-TB | 17                       | 39  | 6000             | 656        |        |
| EAMM-A-L62-80G-G2      | EGC-TB          | 65                       | 151   | 5500             | 1554       |        |
| EAMM-A-L62-100A-G2     | EGC-TB          | 47                       | 151   | 5500             | 1359       |        |
| EAMM-A-L62-150A        | EGC-TB          | 47                       | 151   | 5500             | 2526       |        |
| EAMM-A-L62-88A         | EGC-TB          | 38                       | 147   | 5500             | 977        |        |
| EAMM-A-L62-84AA        | EGC-TB          | 60                       | 147   | 5500             | 1126       |        |
| EAMM-A-L62-108AA       | EGC-TB          | 60                       | 147   | 5500             | 2033       |        |
| EAMM-A-L62-56GA        | EGC-TB          | 38                       | 147   | 5500             | 941        |        |
| EAMM-A-L62-60H         | EGC-TB          | 38                       | 147   | 5500             | 914        |        |
| EAMM-A-L62-70GA        | EGC-TB          | 48                       | 147   | 5500             | 935        |        |
| EAMM-A-L62-75GA        | EGC-TB          | 60                       | 147   | 5500             | 1274       |        |
| EAMM-A-L62-68GA        | EGC-TB          | 48                       | 147   | 5500             | 1197       |        |
| EAMM-A-L62-72GA        | EGC-TB          | 48                       | 147   | 5500             | 1259       |        |
| EAMM-A-L62-90GA        | EGC-TB          | 60                       | 147   | 5500             | 1399       |        |
| EAMM-A-L62-115GA       | EGC-TB          | 60                       | 147   | 5500             | 2296       |        |
| EAMM-A-L62-120G        | EGC-TB          | 47                       | 147   | 5500             | 1798       |        |
| EAMM-A-L62-120GA       | EGC-TB          | 47                       | 147   | 5500             | 1274       |        |

## Datasheet

| General technical data |                          |                          |   |                  |            |        |     |
|------------------------|--------------------------|--------------------------|---|------------------|------------|--------|-----|
| Type                   | For axis                 | Transferable torque [Nm] | Mass moment of inertia [kgmm <sup>2</sup> ] | Max. speed [rpm] | Weight [g] | → Page |     |
| EAMM-A-L62-120GB       | EGC-TB                   | 47                       | 147   | 5500             | 1465       | 88     |     |
| EAMM-A-L62-120GC       | EGC-TB                   | 47                       | 147   | 5500             | 1774       |        |     |
| EAMM-A-L95-80G-G2      | ELGA-TB                  | 120                      | 374   | 4500             | 2771       |        |     |
| EAMM-A-L95-120G-G2     | ELCC-TB, ELGA-TB, EGC-TB | 150                      | 374   | 4500             | 2935       | 88     |     |
| EAMM-A-L95-150A-G2     | ELCC-TB, ELGA-TB, EGC-TB | 143                      | 374   | 4500             | 3180       |        |     |
| EAMM-A-L95-190A-G2     | ELGA-TB, EGC-TB          | 192                      | 374   | 4500             | 4900       | 88     |     |
| EAMM-A-L95-190B-G2     | ELGA-TB, EGC-TB          | 180                      | 402   | 4500             | 4500       |        |     |
| EAMM-A-L95-75GA        | ELGA-TB, EGC-TB          | 133                      | 374   | 4500             | 3087       |        |     |
| EAMM-A-L95-68GA        | ELGA-TB, EGC-TB          | 93                       | 374   | 4500             | 2867       |        |     |
| EAMM-A-L95-72GA        | ELGA-TB, EGC-TB          | 93                       | 374   | 4500             | 2867       |        |     |
| EAMM-A-L95-90GA        | ELGA-TB, EGC-TB          | 133                      | 374   | 4500             | 2793       |        |     |
| EAMM-A-L95-115GA       | ELGA-TB, EGC-TB          | 192                      | 374   | 4500             | 3633       |        |     |
| EAMM-A-L95-120GA       | ELGA-TB, EGC-TB          | 120                      | 374   | 4500             | 2635       |        |     |
| EAMM-A-L95-120GB       | ELGA-TB, EGC-TB          | 150                      | 374   | 4500             | 3113       |        |     |
| EAMM-A-L95-120GC       | ELGA-TB, EGC-TB          | 192                      | 374   | 4500             | 3662       |        |     |
| EAMM-A-L95-160G-G2     | ELGA-TB, EGC-TB          | 200                      | 430   | 4500             | 6264       |        |     |
| EAMM-A-M43-60G         | EGC-HD-TB                | 12.5                     | 14.5  | 8000             | 340        |        | 100 |
| EAMM-A-M43-60H         | EGC-HD-TB                | 12.5                     | 14.5  | 8000             | 330        |        |     |
| EAMM-A-M43-55A         | EGC-HD-TB                | 12.5                     | 14.5  | 8000             | 254        |        |     |
| EAMM-A-M43-70A         | EGC-HD-TB                | 12.5                     | 14.5  | 8000             | 358        |        |     |
| EAMM-A-M43-70AA        | EGC-HD-TB                | 12.5                     | 14.5  | 8000             | 375        |        |     |
| EAMM-A-M43-90R         | EGC-HD-TB                | 12.5                     | 14.5  | 8000             | 510        |        |     |
| EAMM-A-M43-92RA        | EGC-HD-TB                | 12.5                     | 14.5  | 8000             | 687        |        |     |
| EAMM-A-M43-40G         | EGC-HD-TB                | 12.5                     | 14.5  | 8000             | 316        |        |     |
| EAMM-A-M43-50GA        | EGC-HD-TB                | 12.5                     | 14.5  | 8000             | 296        |        |     |
| EAMM-A-M43-56GA        | EGC-HD-TB                | 12.5                     | 14.5  | 8000             | 330        |        |     |
| EAMM-A-M43-70GA        | EGC-HD-TB                | 12.5                     | 14.5  | 8000             | 531        |        |     |
| EAMM-A-M43-68GA        | EGC-HD-TB                | 12.5                     | 14.5  | 8000             | 361        |        |     |
| EAMM-A-M43-72GA        | EGC-HD-TB                | 12.5                     | 14.5  | 8000             | 462        |        |     |
| EAMM-A-M48-60H         | EGC-HD-TB                | 21                       | 39  | 6000             | 320        |        |     |
| EAMM-A-M48-80G         | EGC-HD-TB                | 21                       | 39  | 6000             | 870        |        |     |
| EAMM-A-M48-88A         | EGC-HD-TB                | 21                       | 39  | 6000             | 525        |        |     |
| EAMM-A-M48-84AA        | EGC-HD-TB                | 17                       | 39  | 6000             | 711        |        |     |
| EAMM-A-M48-40G         | EGC-HD-TB                | 17                       | 39  | 6000             | 347        |        |     |
| EAMM-A-M48-50GA        | EGC-HD-TB                | 17                       | 39  | 6000             | 342        |        |     |
| EAMM-A-M48-56GA        | EGC-HD-TB                | 21                       | 39  | 6000             | 390        |        |     |
| EAMM-A-M48-60G         | EGC-HD-TB                | 17                       | 39  | 6000             | 404        |        |     |
| EAMM-A-M48-70GA        | EGC-HD-TB                | 17                       | 39  | 6000             | 493        |        |     |
| EAMM-A-M48-75GA        | EGC-HD-TB                | 17                       | 39  | 6000             | 594        |        |     |
| EAMM-A-M48-68GA        | EGC-HD-TB                | 17                       | 39  | 6000             | 466        |        |     |
| EAMM-A-M48-72GA        | EGC-HD-TB                | 17                       | 39  | 6000             | 517        |        |     |
| EAMM-A-M48-90GA        | EGC-HD-TB                | 17                       | 39  | 6000             | 789        |        |     |
| EAMM-A-M48-120GA       | EGC-HD-TB                | 17                       | 39  | 6000             | 600        |        |     |
| EAMM-A-M80-120G        | EGC-HD-TB                | 75                       | 147   | 5500             | 1370       |        |     |
| EAMM-A-M80-84AA        | EGC-HD-TB                | 60                       | 147   | 5500             | 944        |        |     |
| EAMM-A-M80-75GA        | EGC-HD-TB                | 60                       | 147   | 5500             | 1011       |        |     |
| EAMM-A-M80-80G         | EGC-HD-TB                | 60                       | 147   | 5500             | 771        |        |     |
| EAMM-A-M80-68GA        | EGC-HD-TB                | 48                       | 147   | 5500             | 842        |        |     |
| EAMM-A-M80-90GA        | EGC-HD-TB                | 60                       | 172   | 5500             | 1177       |        |     |
| EAMM-A-M80-115GA       | EGC-HD-TB                | 60                       | 147   | 5500             | 1715       |        |     |
| EAMM-A-M80-120GA       | EGC-HD-TB                | 60                       | 192   | 5500             | 1569       |        |     |
| EAMM-A-M80-120GB       | EGC-HD-TB                | 60                       | 147   | 5500             | 1744       |        |     |
| EAMM-A-M80-120GC       | EGC-HD-TB                | 60                       | 147   | 5500             | 2115       |        |     |



## Datasheet

| General technical data |                           |                          |   |                  |            |        |
|------------------------|---------------------------|--------------------------|---|------------------|------------|--------|
| Type                   | For axis                  | Transferable torque [Nm] | Mass moment of inertia [kgmm <sup>2</sup> ] | Max. speed [rpm] | Weight [g] | → Page |
| EAMM-A-N38-60G-G2      | ELGA-TB                   | 16                       | 14.5  | 8000             | 375        | 88     |
| EAMM-A-N38-60H-G2      | ELGA-TB                   | 16                       | 14.5  | 8000             | 374        |        |
| EAMM-A-N38-60P         | ELGA-TB                   | 12.5                     | 14.5  | 8000             | 314        |        |
| EAMM-A-N38-70A         | ELGA-TB                   | 12.5                     | 14.5  | 8000             | 430        |        |
| EAMM-A-N38-87A         | ELGA-TB                   | 12.5                     | 14.5  | 8000             | 646        |        |
| EAMM-A-N38-60PA        | ELGA-TB                   | 12.5                     | 14.5  | 8000             | 439        |        |
| EAMM-A-N38-60RA        | ELGA-TB                   | 12.5                     | 14.5  | 8000             | 396        |        |
| EAMM-A-N38-70AA        | ELGA-TB                   | 12.5                     | 14.5  | 8000             | 461        |        |
| EAMM-A-N38-88A         | ELGA-TB                   | 12.5                     | 14.5  | 8000             | 594        |        |
| EAMM-A-N38-90R         | ELGA-TB                   | 12.5                     | 14.5  | 8000             | 716        |        |
| EAMM-A-N38-92RA        | ELGA-TB                   | 12.5                     | 14.5  | 8000             | 810        |        |
| EAMM-A-N38-40G         | ELGA-TB                   | 12.5                     | 14.5  | 8000             | 411        |        |
| EAMM-A-N38-50GA        | ELGA-TB                   | 12.5                     | 14.5  | 8000             | 392        |        |
| EAMM-A-N38-56GA        | ELGA-TB                   | 12.5                     | 14.5  | 8000             | 414        |        |
| EAMM-A-N38-70GA        | ELGA-TB                   | 12.5                     | 14.5  | 8000             | 712        |        |
| EAMM-A-N38-68GA        | ELGA-TB                   | 12.5                     | 14.5  | 8000             | 454        |        |
| EAMM-A-N38-72GA        | ELGA-TB                   | 12.5                     | 14.5  | 8000             | 605        |        |
| EAMM-A-N48-40G         | ELGA-TB                   | 12.5                     | 14.5  | 8000             | 401        | 88     |
| EAMM-A-N48-60G-G2      | ELCC-TB, ELGA-TB, ELGD-TB | 21                       | 39  | 6000             | 454        |        |
| EAMM-A-N48-60H-G2      | ELCC-TB, ELGA-TB, ELGD-TB | 21                       | 39  | 6000             | 452        |        |
| EAMM-A-N48-80G-G2      | ELCC-TB, ELGA-TB, ELGD-TB | 21                       | 39  | 6000             | 689        |        |
| EAMM-A-N48-80P         | ELCC-TB, ELGD-TB          | 17                       | 39  | 6000             | 852        |        |
| EAMM-A-N48-80PB        | ELGA-TB, ELGD-TB          | 17                       | 39  | 6000             | 613        |        |
| EAMM-A-N48-100A-G2     | ELCC-TB, ELGA-TB, ELGD-TB | 17                       | 39  | 6000             | 851        |        |
| EAMM-A-N48-60P         | ELGA-TB, ELGD-TB          | 12.5                     | 14.5  | 8000             | 328        |        |
| EAMM-A-N48-60PA        | ELGA-TB, ELGD-TB          | 21                       | 39  | 6000             | 558        |        |
| EAMM-A-N48-70AA        | ELGA-TB, ELGD-TB          | 21                       | 39  | 6000             | 592        |        |
| EAMM-A-N48-80P         | ELGA-TB, ELGD-TB          | 17                       | 39  | 6000             | 883        |        |
| EAMM-A-N48-80PB        | ELGA-TB, ELGD-TB          | 17                       | 39  | 6000             | 613        |        |
| EAMM-A-N48-88A         | ELGA-TB, ELGD-TB          | 21                       | 39  | 6000             | 807        |        |
| EAMM-A-N48-84AA        | ELGA-TB, ELGD-TB          | 17                       | 39  | 6000             | 1139       |        |
| EAMM-A-N48-50GA        | ELGA-TB, ELGD-TB          | 17                       | 39  | 6000             | 519        |        |
| EAMM-A-N48-56GA        | ELGA-TB, ELGD-TB          | 21                       | 39  | 6000             | 577        |        |
| EAMM-A-N48-70GA-G2     | ELGA-TB, ELGD-TB          | 21                       | 39  | 6000             | 770        |        |
| EAMM-A-N48-75GA        | ELGA-TB, ELGD-TB          | 17                       | 39  | 6000             | 756        |        |
| EAMM-A-N48-68GA        | ELGA-TB, ELGD-TB          | 17                       | 39  | 6000             | 627        |        |
| EAMM-A-N48-72GA        | ELGA-TB, ELGD-TB          | 17                       | 39  | 6000             | 679        |        |
| EAMM-A-N48-87A         | ELGA-TB, ELGD-TB          | 12.5                     | 14.5  | 8000             | 504        |        |
| EAMM-A-N48-90GA        | ELGA-TB, ELGD-TB          | 17                       | 39  | 6000             | 1279       |        |
| EAMM-A-N48-120GA       | ELGA-TB, ELGD-TB          | 17                       | 39  | 6000             | 1016       |        |
| EAMM-A-N80-80G-G2      | ELCC-TB, ELGA-TB          | 47                       | 151   | 5500             | 1672       | 88     |
| EAMM-A-N80-120G        | ELGA-TB                   | 47                       | 147   | 5500             | 1990       |        |
| EAMM-A-N80-150A        | ELCC-TB, ELGA-TB          | 47                       | 151   | 5500             | 2410       |        |
| EAMM-A-N80-84AA        | ELGA-TB                   | 47                       | 147   | 5500             | 1409       |        |
| EAMM-A-N80-100A        | ELGA-TB                   | 47                       | 147   | 5500             | 1461       |        |
| EAMM-A-N80-70GA        | ELGA-TB                   | 48                       | 147   | 5500             | 1289       |        |
| EAMM-A-N80-75GA        | ELGA-TB                   | 47                       | 147   | 5500             | 1651       |        |
| EAMM-A-N80-68GA        | ELGA-TB                   | 48                       | 147   | 5500             | 1241       |        |
| EAMM-A-N80-72GA        | ELGA-TB                   | 48                       | 147   | 5500             | 1289       |        |
| EAMM-A-N80-90GA        | ELGA-TB                   | 47                       | 147   | 5500             | 1698       |        |
| EAMM-A-N80-115GA       | ELGA-TB                   | 47                       | 147   | 5500             | 2092       |        |
| EAMM-A-N80-120GA       | ELGA-TB                   | 47                       | 147   | 5500             | 2307       |        |
| EAMM-A-N80-120GB       | ELGA-TB                   | 47                       | 147   | 5500             | 2143       |        |
| EAMM-A-N80-120GC       | ELGA-TB                   | 47                       | 147   | 5500             | 2514       |        |

## Datasheet

| General technical data |                            |                          |   |                  |            |        |
|------------------------|----------------------------|--------------------------|---|------------------|------------|--------|
| Type                   | For axis                   | Transferable torque [Nm] | Mass moment of inertia [kgmm <sup>2</sup> ] | Max. speed [rpm] | Weight [g] | → Page |
| EAMM-A-S38-40A-G2      | EGC-BS, EGC-HD-BS, ELGA-BS | 6.5                      | 5.87  | 8000             | 270        | 96     |
| EAMM-A-S38-40G-G2      | EGC-BS, EGC-HD-BS, ELGA-BS | 6.5                      | 5.87  | 8000             | 410        |        |
| EAMM-A-S38-40P-G2      | EGC-BS, EGC-HD-BS, ELGA-BS | 6.5                      | 5.87  | 8000             | 280        |        |
| EAMM-A-S38-42A-G2      | EGC-BS, EGC-HD-BS, ELGA-BS | 3.5                      | 5.87  | 8000             | 310        |        |
| EAMM-A-S38-50GA        | EGC-BS, EGC-HD-BS, ELGA-BS | 6.5                      | 5.87  | 8000             | 362        |        |
| EAMM-A-S38-55A-G3      | EGC-BS, EGC-HD-BS, ELGA-BS | 6.5                      | 5.87  | 8000             | 260        |        |
| EAMM-A-S38-57A-G2      | EGC-BS, EGC-HD-BS, ELGA-BS | 6.5                      | 5.87  | 8000             | 340        |        |
| EAMM-A-S38-58AA        | EGC-BS, EGC-HD-BS, ELGA-BS | 6.5                      | 5.87  | 8000             | 339        |        |
| EAMM-A-S38-60AA        | EGC-BS, EGC-HD-BS, ELGA-BS | 6.5                      | 5.87  | 8000             | 365        |        |
| EAMM-A-S38-60R-G2      | EGC-BS, EGC-HD-BS, ELGA-BS | 6.5                      | 5.87  | 8000             | 290        |        |
| EAMM-A-S38-60RA-G2     | EGC-BS, EGC-HD-BS, ELGA-BS | 6.5                      | 5.87  | 8000             | 290        |        |
| EAMM-A-S38-60P-G3      | EGC-BS, EGC-HD-BS, ELGA-BS | 6.5                      | 5.87  | 8000             | 290        |        |
| EAMM-A-S48-40G-G2      | EGC-BS, EGC-HD-BS, ELGA-BS | 12.5                     | 5.87  | 8000             | 420        |        |
| EAMM-A-S48-50GA        | EGC-BS, EGC-HD-BS, ELGA-BS | 12.5                     | 5.87  | 8000             | 406        |        |
| EAMM-A-S48-55A-G2      | EGC-BS, EGC-HD-BS, ELGA-BS | 6.5                      | 5.87  | 8000             | 260        |        |
| EAMM-A-S48-57A-G2      | EGC-BS, EGC-HD-BS, ELGA-BS | 6.5                      | 5.87  | 8000             | 570        |        |
| EAMM-A-S48-58AA        | EGC-BS, EGC-HD-BS, ELGA-BS | 12.5                     | 5.87  | 8000             | 373        |        |
| EAMM-A-S48-60AA        | EGC-BS, EGC-HD-BS, ELGA-BS | 12.5                     | 5.87  | 8000             | 415        |        |
| EAMM-A-S48-60G-G3      | EGC-BS, EGC-HD-BS, ELGA-BS | 12.5                     | 5.87  | 8000             | 340        |        |
| EAMM-A-S48-60H-G3      | EGC-BS, EGC-HD-BS, ELGA-BS | 12.5                     | 5.87  | 8000             | 340        |        |
| EAMM-A-S48-60P-G3      | EGC-BS, EGC-HD-BS, ELGA-BS | 12.5                     | 5.87  | 8000             | 280        |        |
| EAMM-A-S48-60R-G2      | EGC-BS, EGC-HD-BS, ELGA-BS | 6.5                      | 5.87  | 8000             | 280        |        |
| EAMM-A-S48-60RA-G2     | EGC-BS, EGC-HD-BS, ELGA-BS | 12.5                     | 5.87  | 8000             | 280        |        |
| EAMM-A-S48-70A-G2      | EGC-BS, EGC-HD-BS, ELGA-BS | 12.5                     | 5.87  | 8000             | 450        |        |
| EAMM-A-S48-70AA        | EGC-BS, EGC-HD-BS, ELGA-BS | 12.5                     | 5.87  | 8000             | 498        |        |
| EAMM-A-S48-80P         | EGC-BS, EGC-HD-BS, ELGA-BS | 17                       | 34.8  | 6000             | 590        |        |
| EAMM-A-S48-80PB        | EGC-BS, EGC-HD-BS, ELGA-BS | 17                       | 34.8  | 6000             | 600        |        |
| EAMM-A-S48-87A-G2      | EGC-BS, EGC-HD-BS, ELGA-BS | 12.5                     | 5.87  | 8000             | 590        |        |
| EAMM-A-S62-60G-G2      | EGC-BS, EGC-HD-BS, ELGA-BS | 21                       | 42.3  | 6500             | 1110       |        |
| EAMM-A-S62-60H-G2      | EGC-BS, EGC-HD-BS, ELGA-BS | 21                       | 42.3  | 6500             | 1100       |        |
| EAMM-A-S62-70A-G2      | EGC-BS, EGC-HD-BS, ELGA-BS | 17                       | 45.5  | 6000             | 1040       |        |
| EAMM-A-S62-70GA        | EGC-BS, EGC-HD-BS, ELGA-BS | 17                       | 34.8  | 6000             | 1109       |        |
| EAMM-A-S62-80G-G3      | EGC-BS, EGC-HD-BS, ELGA-BS | 21                       | 34.8  | 6000             | 1440       |        |
| EAMM-A-S62-80P-G2      | EGC-BS, EGC-HD-BS, ELGA-BS | 17                       | 34.8  | 6000             | 970        |        |
| EAMM-A-S62-80PB        | EGC-BS, EGC-HD-BS, ELGA-BS | 17                       | 34.8  | 6000             | 978        |        |
| EAMM-A-S62-82AA        | EGC-BS, EGC-HD-BS, ELGA-BS | 21                       | 34.8  | 6000             | 1050       |        |
| EAMM-A-S62-84AA        | EGC-BS, EGC-HD-BS, ELGA-BS | 17                       | 34.8  | 6000             | 1037       |        |
| EAMM-A-S62-87A-G2      | EGC-BS, EGC-HD-BS, ELGA-BS | 17                       | 45.5  | 6000             | 1150       |        |
| EAMM-A-S62-100A-G3     | EGC-BS, EGC-HD-BS, ELGA-BS | 21                       | 34.8  | 6000             | 1250       |        |
| EAMM-A-S62-150A-G2     | EGC-BS, EGC-HD-BS, ELGA-BS | 17                       | 34.8  | 6000             | 2160       |        |
| EAMM-A-S95-80G         | EGC-BS, ELGA-BS            | 75                       | 128   | 5500             | 2920       |        |
| EAMM-A-S95-84AA        | EGC-BS, EGC-HD-BS, ELGA-BS | 60                       | 128   | 5500             | 3063       |        |
| EAMM-A-S95-90GA        | EGC-BS, EGC-HD-BS, ELGA-BS | 60                       | 128   | 5500             | 3201       |        |
| EAMM-A-S95-100A-G2     | EGC-BS, EGC-HD-BS, ELGA-BS | 60                       | 128   | 5500             | 2880       |        |
| EAMM-A-S95-120G        | EGC-BS, ELGA-BS            | 75                       | 128   | 5500             | 4350       |        |
| EAMM-A-S95-150A-G2     | EGC-BS, EGC-HD-BS, ELGA-BS | 60                       | 128   | 5500             | 3770       |        |
| EAMM-A-P3-28D-28A      | EGSK                       | 0.2                      | 0.28  | 10000            | 30         | 104    |
| EAMM-A-P3-28D-40P      | EGSK                       | 0.2                      | 0.28  | 10000            | 60         |        |
| EAMM-A-P4-28B-28A      | EGSK                       | 0.7                      | 0.28  | 10000            | 40         |        |
| EAMM-A-P4-28B-38AA     | EGSK                       | 0.7                      | 0.28  | 1000             | 59         |        |
| EAMM-A-P4-28B-40A      | EGSK                       | 0.7                      | 0.28  | 10000            | 50         |        |
| EAMM-A-P4-28B-40P      | EGSK                       | 0.7                      | 0.28  | 10000            | 50         |        |
| EAMM-A-P4-28B-40R      | EGSK                       | 1.1                      | 0.28  | 10000            | 71         |        |
| EAMM-A-P4-28B-40RA     | EGSK                       | 1.1                      | 0.28  | 10000            | 50         |        |
| EAMM-A-P4-28B-42A      | EGSK                       | 0.7                      | 0.28  | 10000            | 60         |        |

## Datasheet

| General technical data |            |                          |   |                  |            |        |
|------------------------|------------|--------------------------|---|------------------|------------|--------|
| Type                   | For axis   | Transferable torque [Nm] | Mass moment of inertia [kgmm <sup>2</sup> ] | Max. speed [rpm] | Weight [g] | → Page |
| EAMM-A-P5-28B-28A      | EGSK       | 1.1                      | 0.28  | 10000            | 40         | 104    |
| EAMM-A-P5-28B-38AA     | EGSK       | 1.1                      | 0.28  | 10000            | 59         |        |
| EAMM-A-P5-28B-40A      | EGSK       | 1.1                      | 0.28  | 10000            | 50         |        |
| EAMM-A-P5-28B-40P      | EGSK       | 1.1                      | 0.28  | 10000            | 50         |        |
| EAMM-A-P5-28B-40R      | EGSK       | 1.1                      | 0.28  | 10000            | 71         |        |
| EAMM-A-P5-28B-RA       | EGSK       | 1.1                      | 0.28  | 10000            | 49         |        |
| EAMM-A-P5-28B-42A      | EGSK       | 1.1                      | 0.28  | 10000            | 60         |        |
| EAMM-A-P6-38A-40A      | EGSK       | 6.5                      | 5.87  | 8000             | 100        |        |
| EAMM-A-P6-38A-40G      | EGSK       | 6.5                      | 5.87  | 8000             | 190        |        |
| EAMM-A-P6-38A-40P      | EGSK       | 6.5                      | 5.87  | 8000             | 110        |        |
| EAMM-A-P6-38A-42A      | EGSK       | 3.5                      | 5.87  | 8000             | 160        |        |
| EAMM-A-P6-38A-55A      | EGSK       | 6.5                      | 5.87  | 8000             | 130        |        |
| EAMM-A-P6-38A-57A      | EGSK       | 6.5                      | 5.87  | 8000             | 130        |        |
| EAMM-A-P6-38A-58AA     | EGSK       | 6.5                      | 5.87  | 8000             | 133        |        |
| EAMM-A-P6-38A-60P      | EGSK       | 6.5                      | 5.87  | 8000             | 210        |        |
| EAMM-A-P6-38A-60R      | EGSK       | 6.5                      | 5.87  | 8000             | 210        |        |
| EAMM-A-P6-38A-60RA     | EGSK       | 6.5                      | 5.87  | 8000             | 209        |        |
| EAMM-A-P8-38A-40A      | EGSK       | 6.5                      | 5.87  | 8000             | 100        |        |
| EAMM-A-P8-38A-40G      | EGSK       | 12.5                     | 5.87  | 8000             | 190        |        |
| EAMM-A-P8-38A-40P      | EGSK       | 12.5                     | 5.87  | 8000             | 110        |        |
| EAMM-A-P8-38A-42A      | EGSK       | 3.5                      | 5.87  | 8000             | 160        |        |
| EAMM-A-P8-38A-55A      | EGSK       | 12.5                     | 5.87  | 8000             | 130        |        |
| EAMM-A-P8-38A-57A      | EGSK       | 6.5                      | 5.87  | 8000             | 130        |        |
| EAMM-A-P8-38A-58AA     | EGSK       | 12.5                     | 5.87  | 8000             | 185        |        |
| EAMM-A-P8-38A-60P      | EGSK       | 12.5                     | 5.87  | 8000             | 210        |        |
| EAMM-A-P8-38A-60AA     | EGSK       | 12.5                     | 5.87  | 8000             | 146        |        |
| EAMM-A-P8-38A-60R      | EGSK       | 12.5                     | 5.87  | 8000             | 145        |        |
| EAMM-A-P8-38A-60RA     | EGSK       | 12.5                     | 5.87  | 8000             | 149        |        |
| EAMM-A-P8-38A-70A      | EGSK       | 12.5                     | 5.87  | 8000             | 200        |        |
| EAMM-A-P8-38A-87A      | EGSK       | 12.5                     | 5.87  | 8000             | 380        |        |
| EAMM-A-R27-40G         | ELGG, ELGR | 2                        | 0.445                                       | 10000            | 240        | 107    |
| EAMM-A-R27-55A         | ELGG, ELGR | 2                        | 0.445                                       | 10000            | 170        |        |
| EAMM-A-R27-57A         | ELGG, ELGR | 1.6                      | 0.355                                       | 10000            | 170        |        |
| EAMM-A-R38-40G         | ELGG, ELGR | 9                        | 3.2   | 8000             | 330        |        |
| EAMM-A-R38-57A         | ELGG, ELGR | 3.6                      | 3.2   | 8000             | 280        |        |
| EAMM-A-R38-60P         | ELGG, ELGR | 4.4                      | 3.3   | 8000             | 350        |        |
| EAMM-A-R38-60G         | ELGG, ELGR | 4.4                      | 3.2   | 8000             | 390        |        |
| EAMM-A-R38-60H         | ELGG, ELGR | 4.4                      | 3.3   | 8000             | 480        |        |
| EAMM-A-R38-70A         | ELGG, ELGR | 4.4                      | 3.2   | 8000             | 350        |        |
| EAMM-A-R38-87A         | ELGG, ELGR | 4.4                      | 3.2   | 8000             | 530        |        |
| EAMM-A-R48-60G         | ELGG, ELGR | 12.5                     | 14.5  | 8000             | 480        |        |
| EAMM-A-R48-60H         | ELGG, ELGR | 12.5                     | 14.5  | 8000             | 480        |        |
| EAMM-A-R48-70A         | ELGG, ELGR | 12.5                     | 14.5  | 8000             | 450        |        |
| EAMM-A-R48-80P         | ELGG, ELGR | 17                       | 39  | 6000             | 710        |        |
| EAMM-A-R48-87A         | ELGG, ELGR | 12.5                     | 14.5  | 8000             | 590        |        |
| EAMM-A-R48-100A        | ELGG, ELGR | 17                       | 39  | 6000             | 970        |        |

## Datasheet

| General technical data |                                       |                          |   |                  |            |        |
|------------------------|---------------------------------------|--------------------------|---|------------------|------------|--------|
| Type                   | For axis                              | Transferable torque [Nm] | Mass moment of inertia [kgmm <sup>2</sup> ] | Max. speed [rpm] | Weight [g] | → Page |
| EAMM-A-T42-55A         | EGSC, ELGC-BS, ELGC-TB, ELGD-BS       | 8.5                      | 3.2   | 8000             | 328        | 102    |
| EAMM-A-T42-57A         | , ELGD-BSEPCC, EGSC, ELGC-BS, ELGC-TB | 6.0                      | 3.2   | 8000             | 330        |        |
| EAMM-A-T42-58AA        | EGSC, ELGC-BS, ELGC-TB, ELGD-BS       | 8.5                      | 3.2   | 8000             | 310        |        |
| EAMM-A-T42-60AA        | EPCC, EGSC, ELGC-BS, ELGC-TB, ELGD-BS | 7.5                      | 3.2   | 8000             | 315        |        |
| EAMM-A-T42-60AB        | EPCC, EGSC, ELGC-BS, ELGC-TB, ELGD-BS | 9.5                      | 3.2   | 8000             | 314        |        |
| EAMM-A-T42-60P         | EPCC, EGSC, ELGC-BS, ELGC-TB, ELGD-BS | 10                       | 3.2   | 8000             | 330        |        |
| EAMM-A-T42-60R         | EPCC, EGSC, ELGC-BS, ELGC-TB, ELGD-BS | 10                       | 3.2   | 8000             | 349        |        |
| EAMM-A-T42-60RA        | EPCC, EGSC, ELGC-BS, ELGC-TB, ELGD-BS | 10                       | 3.2   | 8000             | 348        |        |
| EAMM-A-T42-80P         | EPCC, EGSC, ELGC-BS, ELGC-TB, ELGD-BS | 10                       | 5.8   | 8000             | 500        |        |
| EAMM-A-T42-87A         | EPCC, EGSC, ELGC-BS, ELGC-TB, ELGD-BS | 10                       | 3.2   | 8000             | 400        |        |
| EAMM-A-T46-60P         | ELGC-BS, ELGC-TB, ELGT-BS, ELGD-BS    | 10                       | 3.2   | 8000             | 410        |        |
| EAMM-A-T46-60R         | ELGC-BS, ELGC-TB, ELGT-BS, ELGD-BS    | 10                       | 3.2   | 8000             | 413        |        |
| EAMM-A-T46-60RA        | ELGC-BS, ELGC-TB, ELGT-BS, ELGD-BS    | 10                       | 3.2   | 8000             | 412        |        |
| EAMM-A-T46-70A         | ELGC-BS, ELGC-TB, ELGT-BS, ELGD-BS    | 10                       | 3.2   | 8000             | 574        |        |
| EAMM-A-T46-70AA        | ELGC-BS, ELGC-TB, ELGT-BS, ELGD-BS    | 10                       | 3.2   | 8000             | 601        |        |
| EAMM-A-T46-80P         | ELGC-BS, ELGC-TB, ELGT-BS, ELGD-BS    | 10                       | 5.8   | 8000             | 840        |        |
| EAMM-A-T46-80PA        | ELGC-BS, ELGC-TB, ELGT-BS, ELGD-BS    | 10                       | 7.5   | 8000             | 917        |        |
| EAMM-A-T46-80PB        | ELGC-BS, ELGC-TB, ELGT-BS, ELGD-BS    | 10                       | 7.9   | 8000             | 923        |        |
| EAMM-A-T46-85AA        | ELGC-BS, ELGC-TB, ELGT-BS, ELGD-BS    | 10                       | 3.2   | 8000             | 817        |        |
| EAMM-A-T46-57A         | ELGC-BS, ELGC-TB, ELGT-BS, ELGD-BS    | 6                        | 3.2   | 8000             | 395        |        |
| EAMM-A-T46-87A         | ELGC-BS, ELGC-TB, ELGT-BS, ELGD-BS    | 10                       | 3.2   | 8000             | 630        |        |
| EAMM-A-T46-100A        | ELGC-BS, ELGC-TB, ELGT-BS, ELGD-BS    | 10                       | 5.8   | 8000             | 1080       |        |
| EAMM-A-V20-28A         | EPCC, EGSC                            | 0.2                      | 0.022                                       | 10000            | 27         |        |
| EAMM-A-V20-28AA        | EPCC, EGSC                            | 0.2                      | 0.022                                       | 10000            | 25         |        |
| EAMM-A-V25-38AA        | EPCC, EGSC, ELGC-BS                   | 0.5                      | 0.19  | 10000            | 94         |        |
| EAMM-A-V25-40P         | EPCC, EGSC, ELGC-BS                   | 0.5                      | 0.19  | 10000            | 90         |        |
| EAMM-A-V25-40R         | EPCC, EGSC, ELGC-BS                   | 0.5                      | 0.19  | 10000            | 107        |        |
| EAMM-A-V25-40RA        | EPCC, EGSC, ELGC-BS                   | 0.5                      | 0.19  | 10000            | 94         |        |
| EAMM-A-V25-42A         | EPCC, EGSC, ELGC-BS                   | 0.5                      | 0.19  | 10000            | 83         |        |
| EAMM-A-V25-42AB        | EPCC, EGSC, ELGC-BS                   | 0.5                      | 0.19  | 10000            | 75         |        |
| EAMM-A-V32-38AA        | EPCC, EGSC, ELGC-BS, ELGC-TB          | 1.5                      | 0.18  | 10000            | 112        |        |
| EAMM-A-V32-40P         | EPCC, EGSC, ELGC-BS, ELGC-TB          | 1.5                      | 0.19  | 10000            | 110        |        |
| EAMM-A-V32-40R         | EPCC, EGSC, ELGC-BS, ELGC-TB          | 1.5                      | 0.19  | 10000            | 131        |        |
| EAMM-A-V32-40RA        | EPCC, EGSC, ELGC-BS, ELGC-TB          | 1.5                      | 0.19  | 10000            | 114        |        |
| EAMM-A-V32-42A         | EPCC, EGSC, ELGC-BS, ELGC-TB          | 1.0                      | 0.19  | 10000            | 120        |        |
| EAMM-A-V32-42AB        | EPCC, EGSC, ELGC-BS, ELGC-TB          | 1.0                      | 0.19  | 10000            | 130        |        |
| EAMM-A-V32-57A         | EPCC, EGSC, ELGC-BS, ELGC-TB          | 1.5                      | 0.19  | 10000            | 180        |        |
| EAMM-A-V32-58AA        | EPCC, EGSC, ELGC-BS, ELGC-TB          | 1.5                      | 1.06  | 10000            | 1192       |        |
| EAMM-A-V32-60AA        | EPCC, EGSC, ELGC-BS, ELGC-TB          | 1.5                      | 0.19  | 10000            | 203        |        |
| EAMM-A-V32-60P         | EPCC, EGSC, ELGC-BS, ELGC-TB          | 1.5                      | 1.00  | 10000            | 210        |        |
| EAMM-A-V32-60PA        | EPCC, EGSC, ELGC-BS, ELGC-TB          | 1.5                      | 1.00  | 10000            | 243        |        |
| EAMM-A-V32-60RA        | EPCC, EGSC, ELGC-BS, ELGC-TB          | 1.5                      | 1.00  | 10000            | 243        |        |
| EAMM-A-X22-42A         | EXCM                                  | 0.95                     | 0.195                                       | 27000            | 60         | 109    |
| EAMM-A-X48-57A         | EXCM                                  | 7.5                      | 6.1   | 8000             | 614        |        |
| EAMM-A-X48-87A         | EXCM                                  | 17                       | 34.8  | 6000             | 808        |        |
| EAMM-A-X48-80P         | EXCM                                  | 17                       | 34.8  | 6000             | 821        |        |
| EAMM-A-X62-100A        | EXCH                                  | 47                       | 151   | 5500             | 1428       |        |
| EAMM-A-X62-150A        | EXCH                                  | 47                       | 151   | 5500             | 2340       |        |
| EAMM-A-Y62-100A        | EXCT                                  | 17                       | 39  | 6000             | 1047       | 109    |

## Datasheet

| Operating and environmental conditions       |      |                    |
|--|------|--------------------|
| Ambient temperature                          | [°C] | -10 ... +60        |
| Storage temperature                          | [°C] | -25 ... +60        |
| Degree of protection <sup>1)</sup>           |      |                    |
| EAMM-A-...                                   |      | IP40               |
| EAMM-A-...-S1                                |      | IP65               |
| Relative humidity                            | [%]  | 0 ... 95           |
| Corrosion resistance class CRC <sup>2)</sup> |      | 1                  |
| Note on materials                            |      | RoHS-compliant     |
| LABS (PWIS) conformity                       |      |                    |
| EAMM-A-...                                   |      | VDMA24364-B2-L     |
| EAMM-A-D19-...                               |      | VDMA24364 zone III |
| EAMM-A-D...-S1                               |      | VDMA24364 zone III |

1) Only in combination with attached motor and axis

2) Corrosion resistance class CRC 1 to Festo standard FN 940070

Low corrosion stress. Dry indoor applications or transport and storage protection. Also applies to parts behind covers, in the non-visible interior area, or parts that are covered in the application (e.g. drive trunnions).

Datasheet

Dimensions (sample illustration)

Download CAD data → [www.festo.com](http://www.festo.com)

EGSL-...

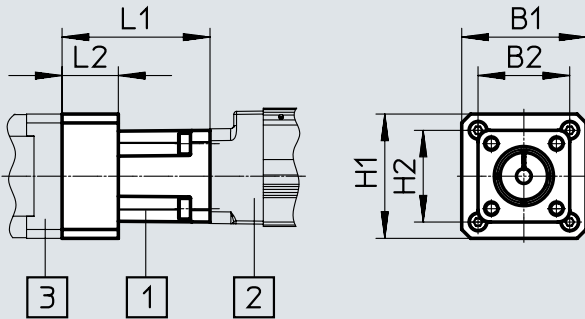

Main illustration:

- [1] Axial kit
- [2] Mini slide
- [3] Motor

ESBF-... with degree of protection IP40

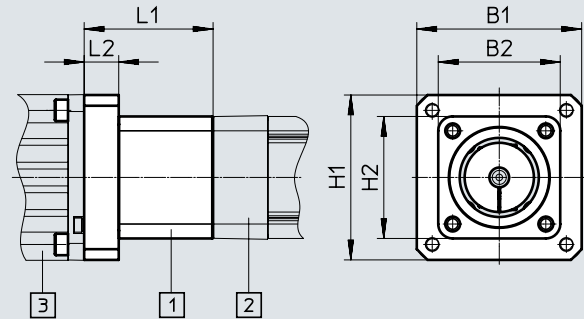

Main illustration:

- [1] Axial kit
- [2] Electric cylinder
- [3] Motor

ERMB-...

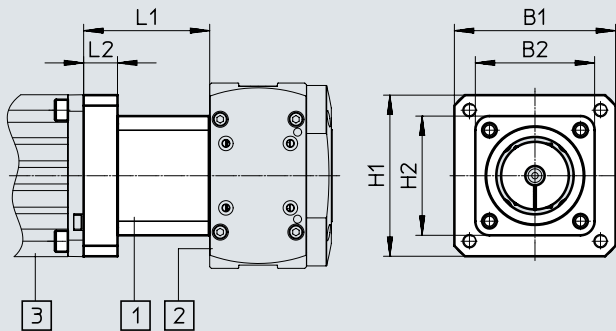

Main illustration:

- [1] Axial kit
- [2] Rotary module
- [3] Motor

EHMB-...

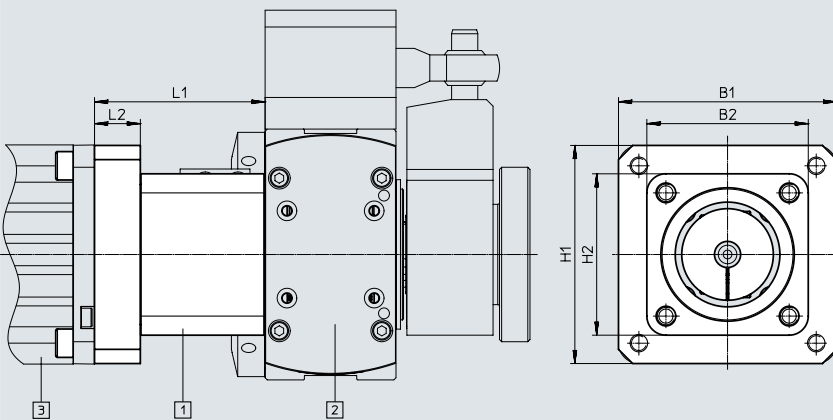

Main illustration:

- [1] Axial kit
- [2] Rotary/lifting module
- [3] Motor

## Datasheet

| Type               | B1   | B2   | H1   | H2   | L1   | L2   |
|--------------------|------|------|------|------|------|------|
| EAMM-A-D19-28A     | 30   | 31   | 30   | 31   | 46.2 | 15   |
| EAMM-A-D19-38AA    | 38   | 31   | 38   | 31   | 51.2 | 20   |
| EAMM-A-D19-40A     | 40   | 31   | 40   | 31   | 42.7 | 11.5 |
| EAMM-A-D19-40P     | 39.7 | 31   | 39.7 | 31   | 45.7 | 14.5 |
| EAMM-A-D19-40R     | 40   | 31   | 40   | 31   | 51.2 | 20   |
| EAMM-A-D19-42A     | 42   | 31   | 42   | 31   | 50   | 19   |
| EAMM-A-D32-35A-40A | 40   | 40   | 40   | 40   | 46   | –    |
| EAMM-A-D32-35A-40P | 39.7 | 39.7 | 39.7 | 39.7 | 49.5 | –    |
| EAMM-A-D32-40A     | 40   | 45   | 40   | 45   | 39.8 | 8.3  |
| EAMM-A-D32-40G     | 60   | 45   | 60   | 45   | 62.5 | 24   |
| EAMM-A-D32-40P     | 39.7 | 45   | 39.7 | 45   | 44   | 12.5 |
| EAMM-A-D32-40R     | 53.5 | 45   | 53.5 | 45   | 49.8 | 11.1 |
| EAMM-A-D32-42A     | 42   | 45   | 42   | 45   | 48   | 5    |
| EAMM-A-D32-50GA    | 62   | 45   | 62   | 45   | 62.5 | 31.5 |
| EAMM-A-D32-55A     | 55   | 45   | 55   | 45   | 49.2 | 10.5 |
| EAMM-A-D32-57A     | 56.4 | 45   | 56.4 | 45   | 50.5 | 12   |
| EAMM-A-D32-58AA    | 58   | 45   | 58   | 45   | 51.2 | 12.5 |
| EAMM-A-D32-60AA    | 60   | 45   | 60   | 45   | 50.7 | 12   |
| EAMM-A-D32-60G     | 75   | 45   | 75   | 45   | 66.5 | 28   |
| EAMM-A-D32-60H     | 75   | 45   | 75   | 45   | 66.5 | 28   |
| EAMM-A-D32-60P-G2  | 62   | 45   | 62   | 45   | 51   | 20   |
| EAMM-A-D32-60R     | 62   | 45   | 62   | 45   | 51   | 20   |
| EAMM-A-D32-60RA    | 62   | 45   | 62   | 45   | 51   | 20   |
| EAMM-A-D40-40G-G2  | 60   | 54   | 60   | 54   | 62.5 | 24   |
| EAMM-A-D40-50GA    | 62   | 54   | 62   | 54   | 62.5 | 31.5 |
| EAMM-A-D40-55A     | 55   | 54   | 55   | 54   | 49.2 | 10.5 |
| EAMM-A-D40-57A     | 56.4 | 54   | 56.4 | 54   | 50.5 | 12   |
| EAMM-A-D40-58AA    | 58   | 54   | 58   | 54   | 51.2 | 12.5 |
| EAMM-A-D40-60AA    | 60   | 54   | 60   | 54   | 50.7 | 12   |
| EAMM-A-D40-60G     | 75   | 54   | 75   | 54   | 66.5 | 28   |
| EAMM-A-D40-60H     | 75   | 54   | 75   | 54   | 66.5 | 28   |
| EAMM-A-D40-60P-G2  | 62   | 54   | 62   | 54   | 51   | 20   |
| EAMM-A-D40-60R     | 62   | 54   | 62   | 54   | 51   | 20   |
| EAMM-A-D40-60RA    | 62   | 54   | 62   | 54   | 51   | 20   |
| EAMM-A-D40-70A     | 70   | 54   | 70   | 54   | 52   | 13.5 |
| EAMM-A-D40-70AA    | 72   | 54   | 72   | 54   | 53.5 | 13   |
| EAMM-A-D40-87A     | 85.8 | 54   | 85.8 | 54   | 54   | 15.5 |

Datasheet

Dimensions (sample illustration)

Download CAD data → [www.festo.com](http://www.festo.com)

EGSL-...

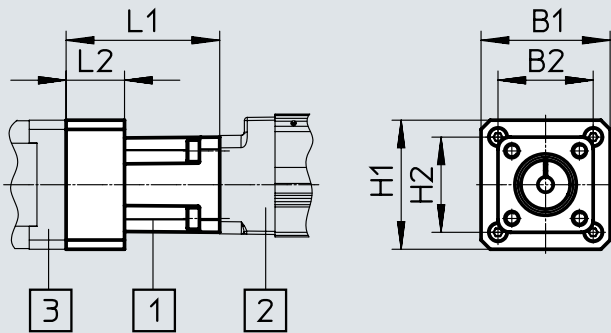

Main illustration:

- [1] Axial kit
- [2] Mini slide
- [3] Motor

ESBF-... with degree of protection IP40

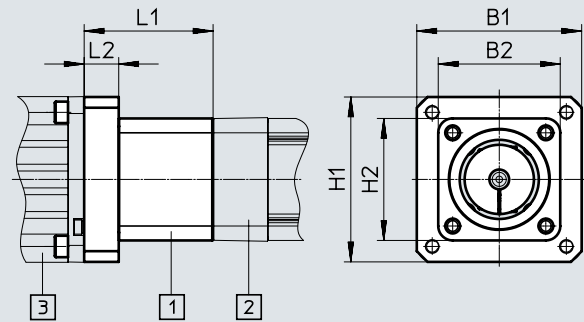

Main illustration:

- [1] Axial kit
- [2] Electric cylinder
- [3] Motor

ERMB-...

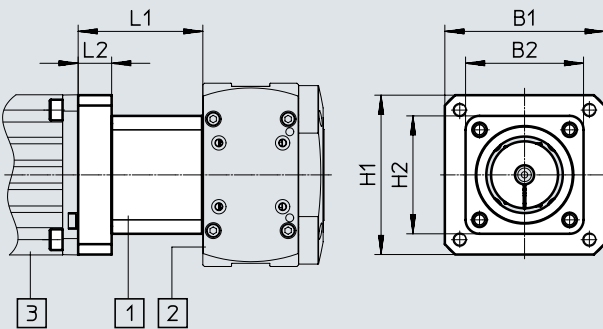

Main illustration:

- [1] Axial kit
- [2] Rotary module
- [3] Motor

EHMB-...

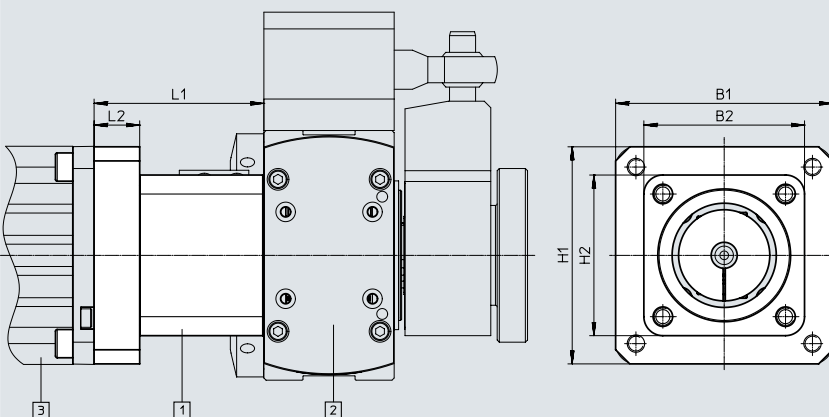

Main illustration:

- [1] Axial kit
- [2] Rotary/lifting module
- [3] Motor





## Datasheet

| Type               | B1   | B2  | H1   | H2  | L1    | L2   |
|--------------------|------|-----|------|-----|-------|------|
| EAMM-A-D50-60G-G2  | 82   | 64  | 82   | 64  | 77.5  | 31   |
| EAMM-A-D50-60H-G2  | 82   | 64  | 82   | 64  | 77.5  | 31   |
| EAMM-A-D50-70A     | 70   | 74  | 70   | 74  | 68.2  | 16.2 |
| EAMM-A-D50-70GA    | 85.8 | 65  | 85.8 | 65  | 83.7  | 31.5 |
| EAMM-A-D50-80G     | 104  | 74  | 104  | 74  | 92.4  | 30   |
| EAMM-A-D50-80P-G2  | 82   | 64  | 82   | 64  | 77.5  | 21   |
| EAMM-A-D50-80PB-G2 | 82   | 64  | 82   | 64  | 77.5  | 21   |
| EAMM-A-D50-82AA    | 82   | 65  | 82   | 65  | 68.2  | 16   |
| EAMM-A-D50-84AA    | 96   | 65  | 96   | 65  | 79.7  | 17.5 |
| EAMM-A-D50-87A     | 85.8 | 74  | 85.8 | 74  | 69.7  | 17.5 |
| EAMM-A-D50-100A    | 100  | 74  | 100  | 74  | 83.2  | 21   |
| EAMM-A-D60-60G-G2  | 90   | 74  | 90   | 74  | 82.4  | 35   |
| EAMM-A-D60-60H     | 90   | 74  | 90   | 74  | 82.4  | 35   |
| EAMM-A-D60-70A     | 70   | 74  | 70   | 74  | 64.2  | 16   |
| EAMM-A-D60-80G-G2  | 104  | 75  | 104  | 75  | 77.4  | 32   |
| EAMM-A-D60-80P     | 81.3 | 74  | 81.3 | 74  | 74.7  | 17.5 |
| EAMM-A-D60-80PB    | 81.3 | 74  | 81.3 | 74  | 74.7  | 17.5 |
| EAMM-A-D60-84AA    | 96   | 74  | 96   | 74  | 74.7  | 17.5 |
| EAMM-A-D60-92RA    | 90   | 74  | 90   | 74  | 75    | 28   |
| EAMM-A-D60-87A     | 85.8 | 74  | 85.8 | 74  | 64.7  | 17.5 |
| EAMM-A-D60-90GA    | 104  | 75  | 104  | 75  | 93.9  | 38.5 |
| EAMM-A-D60-100A-G2 | 104  | 75  | 104  | 75  | 77.4  | 22   |
| EAMM-A-D80-80G     | 104  | 100 | 104  | 100 | 102   | 30   |
| EAMM-A-D80-84AA    | 100  | 100 | 100  | 100 | 85.2  | 13   |
| EAMM-A-D80-90GA    | 104  | 100 | 104  | 100 | 108.5 | 36.5 |
| EAMM-A-D80-100A    | 100  | 100 | 100  | 100 | 92    | 20   |
| EAMM-A-D80-150A    | 151  | 100 | 151  | 100 | 102   | 30   |
| EAMM-A-D100-100A   | 100  | 112 | 100  | 112 | 99.5  | 20   |
| EAMM-A-D100-120G   | 143  | 112 | 143  | 112 | 113.5 | 34   |
| EAMM-A-D100-150A   | 151  | 109 | 151  | 109 | 102   | 30   |

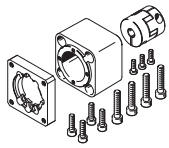
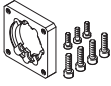
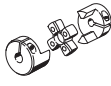
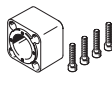
## Datasheet

| Ordering data – Individual components   |   |  |   |
|---|---|--|---|
| Axial kit   | Consisting of:  |  |   |
|   | Motor flange  | Coupling   | Coupling housing  |
|  |  |  |  |
| Part no.<br>Type  | Part no.<br>Type  | Part no.<br>Type   | Part no.<br>Type  |
| 1081659<br>EAMM-A-D19-28A   | 1087613<br>EAMF-A-28D-28A   | 562676<br>EAMC-16-20-5-5   | 1087585<br>EAMK-A-D19-28D   |
| 1199152<br>EAMM-A-D19-40A   | 1199144<br>EAMF-A-28D-40A   | 543419<br>EAMC-16-20-5-6   | 1087585<br>EAMK-A-D19-28D   |
| 1981953<br>EAMM-A-D19-40P   | 1982014<br>EAMF-A-28D-40P   | 562677<br>EAMC-16-20-5-8   | 1087585<br>EAMK-A-D19-28D   |
| 1087642<br>EAMM-A-D19-42A   | 1087630<br>EAMF-A-28D-42A   | 562676<br>EAMC-16-20-5-5   | 1087585<br>EAMK-A-D19-28D   |
| 560281<br>EAMM-A-D32-35A-40A  | –   | 558312<br>EAMC-30-32-6-6   | 560280<br>EAMK-A-D32-35A-40A  |
| 2207441<br>EAMM-A-D32-35A-40P   | –   | 533708<br>EAMC-30-32-6-8   | 2207509<br>EAMK-A-D32-35A-40P   |
| 543147<br>EAMM-A-D32-40A  | 552163<br>EAMF-A-28B-40A  | 543420<br>EAMC-16-20-6-6   | 552155<br>EAMK-A-D32-28B  |
| 1454238<br>EAMM-A-D32-40G   | 1460095<br>EAMF-A-44C-40G-S1  | 562681<br>EAMC-30-32-6-10  | 551006<br>EAMK-A-D32-44A/C  |
| 1976465<br>EAMM-A-D32-40P   | 1976704<br>EAMF-A-28B-40P   | 1232854<br>EAMC-16-20-6-8  | 552155<br>EAMK-A-D32-28B  |
| 543148<br>EAMM-A-D32-42A  | 552164<br>EAMF-A-28B-42A  | 543419<br>EAMC-16-20-5-6   | 552155<br>EAMK-A-D32-28B  |
| 550979<br>EAMM-A-D32-55A  | 529942<br>EAMF-A-44A/B-55A  | 551003<br>EAMC-30-32-6-9   | 551006<br>EAMK-A-D32-44A/C  |
| 550980<br>EAMM-A-D32-57A  | 530081<br>EAMF-A-44A/B-57A  | 551002<br>EAMC-30-32-6-6.35  | 551006<br>EAMK-A-D32-44A/C  |
| 2946758<br>EAMM-A-D32-60G   | 1460105<br>EAMF-A-44C-60G/H-S1  | 318577<br>EAMC-30-32-6-11  | 551006<br>EAMK-A-D32-44A/C  |
| 2946760<br>EAMM-A-D32-60H   | 1460105<br>EAMF-A-44C-60G/H-S1  | 1233256<br>EAMC-30-32-6-14   | 551006<br>EAMK-A-D32-44A/C  |
| 8197499<br>EAMM-A-D32-60P-G2  | –   | 1233256<br>EAMC-30-32-6-14   | –   |

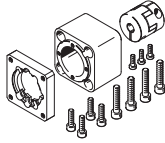
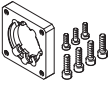
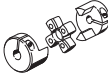
## Datasheet

| Ordering data – Individual components   |   |  |   |
|---|---|--|---|
| Axial kit   | Consisting of:  |  |   |
|   | Motor flange  | Coupling   | Coupling housing  |
|  |  |  |  |
| Part no.<br>Type  | Part no.<br>Type  | Part no.<br>Type   | Part no.<br>Type  |
| 2256398<br>EAMM-A-D40-40G-G2  | 1460095<br>EAMF-A-44C-40G-S1  | 558029<br>EAMC-30-32-8-10  | 552157<br>EAMK-A-D40-44A/C  |
| 543153<br>EAMM-A-D40-55A  | 529942<br>EAMF-A-44A/B-55A  | 543423<br>EAMC-30-32-8-9   | 552157<br>EAMK-A-D40-44A/C  |
| 543154<br>EAMM-A-D40-57A  | 530081<br>EAMF-A-44A/B-57A  | 543421<br>EAMC-30-32-6.35-8  | 552157<br>EAMK-A-D40-44A/C  |
| 2256400<br>EAMM-A-D40-60G   | 1460105<br>EAMF-A-44C-60G/H-S1  | 551004<br>EAMC-30-32-8-11  | 552157<br>EAMK-A-D40-44A/C  |
| 1454242<br>EAMM-A-D40-60H   | 1460105<br>EAMF-A-44C-60G/H-S1  | 562682<br>EAMC-30-32-8-14  | 552157<br>EAMK-A-D40-44A/C  |
| 8197493<br>EAMM-A-D40-60P-G2  | –   | 562682<br>EAMC-30-32-8-14  | –   |
| 550981<br>EAMM-A-D40-70A  | 529943<br>EAMF-A-44A/B-70A  | 551004<br>EAMC-30-32-8-11  | 552157<br>EAMK-A-D40-44A/C  |
| 550982<br>EAMM-A-D40-87A  | 530082<br>EAMF-A-44A/B-87A  | 551004<br>EAMC-30-32-8-11  | 552157<br>EAMK-A-D40-44A/C  |
| 8197498<br>EAMM-A-D50-60G-G2  | –   | 8086048<br>EAMC-42-50-11-12-U  | –   |
| 8197492<br>EAMM-A-D50-60H-G2  | –   | 8086048<br>EAMC-42-50-11-12-U  | –   |
| 2733783<br>EAMM-A-D50-70A   | 529945<br>EAMF-A-64A/B-70A  | 543424<br>EAMC-42-50-11-12   | 2733780<br>EAMK-A-D50-64B   |
| 2733787<br>EAMM-A-D50-80G   | 2843290<br>EAMF-A-64C-80G-S1  | 2138701<br>EAMC-42-50-12-20  | 2836865<br>EAMK-A-D50-64C   |
| 8197489<br>EAMM-A-D50-80P-G2  | –   | 8101555<br>EAMC-42-50-12-19-U  | –   |
| 8197488<br>EAMM-A-D50-80PB-G2   | –   | 8099433<br>EAMC-42-50-12-16-U  | –   |
| 2733781<br>EAMM-A-D50-87A   | 533140<br>EAMF-A-64A/B-87A  | 543424<br>EAMC-42-50-11-12   | 2733780<br>EAMK-A-D50-64B   |
| 2733784<br>EAMM-A-D50-100A  | 529947<br>EAMF-A-64A/C/D-100A   | 551005<br>EAMC-42-50-12-19   | 2836865<br>EAMK-A-D50-64C   |

## Datasheet

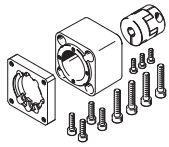
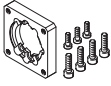
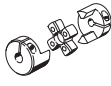
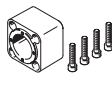
| Ordering data – Individual components   |   |  |   |
|---|---|--|---|
| Axial kit   | Consisting of:  |  |   |
|   | Motor flange  | Coupling   | Coupling housing  |
|  |  |  |  |
| Part no.<br>Type  | Part no.<br>Type  | Part no.<br>Type   | Part no.<br>Type  |
| 2256696<br>EAMM-A-D60-60G-G2  | 2256289<br>EAMF-A-64B-60G/H-S1  | 543424<br>EAMC-42-50-11-12   | 552160<br>EAMK-A-D60-64B  |
| 1454245<br>EAMM-A-D60-60H   | 2256289<br>EAMF-A-64B-60G/H-S1  | 1455671<br>EAMC-42-50-12-14  | 552160<br>EAMK-A-D60-64B  |
| 543161<br>EAMM-A-D60-70A  | 529945<br>EAMF-A-64A/B-70A  | 543424<br>EAMC-42-50-11-12   | 552160<br>EAMK-A-D60-64B  |
| 8199480<br>EAMM-A-D60-80G-G2  | –   | 8086049<br>EAMC-42-50-12-20-U  | –   |
| 1977073<br>EAMM-A-D60-80P   | 1977113<br>EAMF-A-64A/C-80P   | 551005<br>EAMC-42-50-12-19   | 551007<br>EAMK-A-D60-64C  |
| 543162<br>EAMM-A-D60-87A  | 533140<br>EAMF-A-64A/B-87A  | 543424<br>EAMC-42-50-11-12   | 552160<br>EAMK-A-D60-64B  |
| 8197500<br>EAMM-A-D60-100A-G2   | –   | 8101555<br>EAMC-42-50-12-19-U  | –   |
| 2946763<br>EAMM-A-D80-80G   | 2933286<br>EAMF-A-77A-80G-S1  | 3181801<br>EAMC-56-58-19-20  | 1593627<br>EAMK-A-D80-77A   |
| 1589665<br>EAMM-A-D80-100A  | 1593628<br>EAMF-A-77A-100A  | 1485673<br>EAMC-56-58-19-19  | 1593627<br>EAMK-A-D80-77A   |
| 8157273<br>EAMM-A-D80-150A  | –   | 1485674<br>EAMC-56-58-19-24  | –   |
| 3356796<br>EAMM-A-D100-100A   | 1593628<br>EAMF-A-77A-100A  | 1485674<br>EAMC-56-58-19-24  | 1593914<br>EAMK-A-D100-77A/B  |
| 2449341<br>EAMM-A-D100-120G   | 2449380<br>EAMF-A-77B-120G-S1   | 3187895<br>EAMC-67-62-24-25  | 1593914<br>EAMK-A-D100-77A/B  |
| 8157275<br>EAMM-A-D100-150A   | –   | 1451407<br>EAMC-67-62-24-24  | –   |

## Datasheet

## Dimensions (sample illustration)

Download CAD data → [www.festo.com](http://www.festo.com)

ESBF... with degree of protection IP65

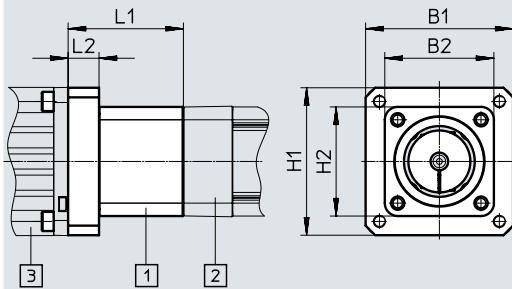

Main illustration:

- [1] Axial kit
- [2] Electric cylinder
- [3] Motor

| Type                  | B1   | B2  | H1   | H2  | L1    | L2   |
|-----------------------|------|-----|------|-----|-------|------|
| EAMM-A-D32-40A-S1     | 40   | 45  | 40   | 45  | 41.3  | 8.8  |
| EAMM-A-D32-40G-S1     | 60   | 45  | 60   | 45  | 62.5  | 24   |
| EAMM-A-D32-40P-S1     | 39.7 | 45  | 39.7 | 45  | 45.5  | 13   |
| EAMM-A-D32-42A-S1     | 42   | 45  | 42   | 45  | 49.5  | 5.5  |
| EAMM-A-D32-55A-S1     | 55   | 45  | 55   | 45  | 50.7  | 11   |
| EAMM-A-D32-57A-S1     | 56.4 | 45  | 56.4 | 45  | 52    | 12.5 |
| EAMM-A-D32-60G-S1     | 75   | 45  | 75   | 45  | 67.5  | 28.5 |
| EAMM-A-D32-60H-S1     | 75   | 45  | 75   | 45  | 67.5  | 28.5 |
| EAMM-A-D32-60P-S1-G2  | 62   | 45  | 62   | 45  | 52    | 20.5 |
| EAMM-A-D40-40G-S1     | 60   | 54  | 60   | 54  | 63.5  | 24.5 |
| EAMM-A-D40-55A-S1     | 55   | 54  | 55   | 54  | 50.7  | 11   |
| EAMM-A-D40-57A-S1     | 56.4 | 54  | 56.4 | 54  | 52    | 12.5 |
| EAMM-A-D40-60G-S1     | 75   | 54  | 75   | 54  | 67.5  | 28.5 |
| EAMM-A-D40-60H-S1     | 75   | 54  | 75   | 54  | 67.5  | 28.5 |
| EAMM-A-D40-60P-S1-G2  | 62   | 54  | 62   | 54  | 52    | 20.5 |
| EAMM-A-D40-70A-S1     | 70   | 54  | 70   | 54  | 53    | 14   |
| EAMM-A-D40-87A-S1     | 85.8 | 54  | 85.8 | 54  | 55    | 16   |
| EAMM-A-D50-60G-S1-G2  | 82   | 64  | 82   | 64  | 78.5  | 31.5 |
| EAMM-A-D50-60H-S1-G2  | 82   | 64  | 82   | 64  | 78.5  | 31.5 |
| EAMM-A-D50-70A-S1     | 70   | 74  | 70   | 74  | 69.2  | 16.5 |
| EAMM-A-D50-80G-S1     | 104  | 74  | 104  | 74  | 93.4  | 30.5 |
| EAMM-A-D50-80P-S1-G2  | 82   | 64  | 82   | 64  | 78.5  | 21.5 |
| EAMM-A-D50-87A-S1     | 85.8 | 74  | 85.8 | 74  | 70.7  | 18   |
| EAMM-A-D50-100A-S1    | 100  | 74  | 100  | 74  | 84.2  | 21.5 |
| EAMM-A-D60-60G-S1     | 90   | 74  | 90   | 74  | 83.4  | 35.5 |
| EAMM-A-D60-60H-S1     | 90   | 74  | 90   | 74  | 83.4  | 35.5 |
| EAMM-A-D60-70A-S1     | 70   | 74  | 70   | 74  | 64.2  | 16.5 |
| EAMM-A-D60-80G-S1-G2  | 104  | 75  | 104  | 75  | 78.4  | 32.5 |
| EAMM-A-D60-80P-S1     | 81.3 | 74  | 81.3 | 74  | 75.7  | 18   |
| EAMM-A-D60-87A-S1     | 85.8 | 74  | 85.8 | 74  | 66.5  | 18   |
| EAMM-A-D60-100A-S1-G2 | 104  | 75  | 104  | 75  | 78.4  | 22.5 |
| EAMM-A-D80-80G-S1     | 104  | 100 | 104  | 100 | 103.5 | 30.5 |
| EAMM-A-D80-100A-S1    | 100  | 100 | 100  | 100 | 93.5  | 20.5 |
| EAMM-A-D80-150A-S1    | 151  | 100 | 151  | 100 | 103   | 30.5 |
| EAMM-A-D100-100A-S1   | 100  | 112 | 100  | 112 | 101   | 20   |
| EAMM-A-D100-120G-S1   | 143  | 112 | 143  | 112 | 115   | 34.5 |
| EAMM-A-D100-150A-S1   | 151  | 109 | 151  | 109 | 103   | 30.5 |

## Datasheet

## Ordering data – Individual components

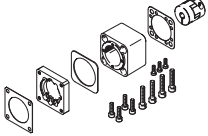
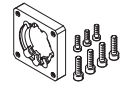
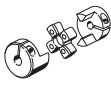
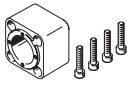
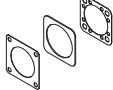
| Axial kit   | Consisting of:  |   |  |   |
|---|---|---|--|---|
|   | Motor flange  | Coupling  | Coupling housing   | Seal set  |
|  |  |  |  |  |
| Part no.<br>Type  | Part no.<br>Type  | Part no.<br>Type  | Part no.<br>Type   | Part no.<br>Type  |
| 1322178<br>EAMM-A-D32-40A-S1  | 552163<br>EAMF-A-28B-40A  | 543420<br>EAMC-16-20-6-6  | 552155<br>EAMK-A-D32-28B   | 1561526<br>EADS-F-D32-40A   |
| 2256396<br>EAMM-A-D32-40G-S1  | 1460095<br>EAMF-A-44C-40G-S1  | 562681<br>EAMC-30-32-6-10   | 551006<br>EAMK-A-D32-44A/C   | 2253500<br>EADS-F-D32-40G   |
| 2207372<br>EAMM-A-D32-40P-S1  | 1976704<br>EAMF-A-28B-40P   | 1232854<br>EAMC-16-20-6-8   | 552155<br>EAMK-A-D32-28B   | 2207219<br>EADS-F-D32-40P   |
| 1322179<br>EAMM-A-D32-42A-S1  | 552164<br>EAMF-A-28B-42A  | 543419<br>EAMC-16-20-5-6  | 552155<br>EAMK-A-D32-28B   | 1561527<br>EADS-F-D32-42A   |
| 1322180<br>EAMM-A-D32-55A-S1  | 529942<br>EAMF-A-44A/B-55A  | 551003<br>EAMC-30-32-6-9  | 551006<br>EAMK-A-D32-44A/C   | 1561528<br>EADS-F-D32-55A   |
| 1322181<br>EAMM-A-D32-57A-S1  | 530081<br>EAMF-A-44A/B-57A  | 551002<br>EAMC-30-32-6-6.35   | 551006<br>EAMK-A-D32-44A/C   | 1561529<br>EADS-F-D32-57A   |
| 2946759<br>EAMM-A-D32-60G-S1  | 1460105<br>EAMF-A-44C-60G/H-S1  | 3187577<br>EAMC-30-32-6-11  | 551006<br>EAMK-A-D32-44A/C   | 8022150<br>EADS-F-D32-60G/H   |
| 2946761<br>EAMM-A-D32-60H-S1  | 1460105<br>EAMF-A-44C-60G/H-S1  | 1233256<br>EAMC-30-32-6-14  | 551006<br>EAMK-A-D32-44A/C   | 8022150<br>EADS-F-D32-60G/H   |
| 8197495<br>EAMM-A-D32-60P-S1-G2   | –   | 1233256<br>EAMC-30-32-6-14  | –  | 8197395<br>EADS-F-D32-60P-G2  |
| 2256399<br>EAMM-A-D40-40G-S1  | 1460095<br>EAMF-A-44C-40G-S1  | 558029<br>EAMC-30-32-8-10   | 552157<br>EAMK-A-D40-44A/C   | 2253502<br>EADS-F-D40-40G   |
| 1322182<br>EAMM-A-D40-55A-S1  | 529942<br>EAMF-A-44A/B-55A  | 543423<br>EAMC-30-32-8-9  | 552157<br>EAMK-A-D40-44A/C   | 1561530<br>EADS-F-D40-55A   |
| 1322183<br>EAMM-A-D40-57A-S1  | 530081<br>EAMF-A-44A/B-57A  | 543421<br>EAMC-30-32-6.35-8   | 552157<br>EAMK-A-D40-44A/C   | 1561531<br>EADS-F-D40-57A   |
| 2256409<br>EAMM-A-D40-60G-S1  | 1460105<br>EAMF-A-44C-60G/H-S1  | 551004<br>EAMC-30-32-8-11   | 552157<br>EAMK-A-D40-44A/C   | 2253503<br>EADS-F-D40-60G/H   |
| 2256401<br>EAMM-A-D40-60H-S1  | 1460105<br>EAMF-A-44C-60G/H-S1  | 562682<br>EAMC-30-32-8-14   | 552157<br>EAMK-A-D40-44A/C   | 2253503<br>EADS-F-D40-60G/H   |
| 8197497<br>EAMM-A-D40-60P-S1-G2   | –   | 562682<br>EAMC-30-32-8-14   | –  | 8197397<br>EADS-F-D40-60P-G2  |
| 1322185<br>EAMM-A-D40-70A-S1  | 529943<br>EAMF-A-44A/B-70A  | 551004<br>EAMC-30-32-8-11   | 552157<br>EAMK-A-D40-44A/C   | 1561532<br>EADS-F-D40-70A   |
| 1322186<br>EAMM-A-D40-87A-S1  | 530082<br>EAMF-A-44A/B-87A  | 551004<br>EAMC-30-32-8-11   | 552157<br>EAMK-A-D40-44A/C   | 1561533<br>EADS-F-D40-87A   |

## Datasheet

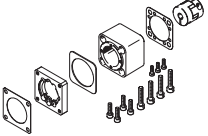
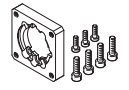
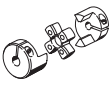
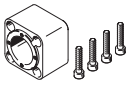
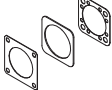
| Ordering data – Individual components   |   |   |   |   |
|---|---|---|---|---|
| Axial kit   | Consisting of:  |   |   |   |
|   | Motor flange  | Coupling  | Coupling housing  | Seal set  |
|  |  |  |  |  |
| Part no.<br>Type  | Part no.<br>Type  | Part no.<br>Type  | Part no.<br>Type  | Part no.<br>Type  |
| 8197496<br>EAMM-A-D50-60G-S1-G2   | –   | 8066048<br>EAMC-42-50-11-12-U   | –   | 8197506<br>EADS-F-D50-60G/H-G2  |
| 8197491<br>EAMM-A-D50-60H-S1-G2   | –   | 8066048<br>EAMC-42-50-11-12-U   | –   | 8197506<br>EADS-F-D50-60G/H-G2  |
| 2734287<br>EAMM-A-D50-70A-S1  | 529945<br>EAMF-A-64A/B-70A  | 543424<br>EAMC-42-50-11-12  | 2733780<br>EAMK-A-D50-64B   | 2733789<br>EADS-F-D50-70A   |
| 2734291<br>EAMM-A-D50-80G-S1  | 2843290<br>EAMF-A-64C-80G-S1  | 2138701<br>EAMC-42-50-12-20   | 2836865<br>EAMK-A-D50-64C   | 2733793<br>EADS-F-D50-80G   |
| 8197494<br>EAMM-A-D50-80P-S1-G2   | –   | 8101555<br>EAMC-42-50-12-19-U   | –   | 8197394<br>EADS-F-D50-80P-G2  |
| 2734286<br>EAMM-A-D50-87A-S1  | 533140<br>EAMF-A-64A/B-87A  | 543424<br>EAMC-42-50-11-12  | 2733780<br>EAMK-A-D50-64B   | 2733788<br>EADS-F-D50-87A   |
| 2734288<br>EAMM-A-D50-100A-S1   | 529947<br>EAMF-A-64A/C/D-100A   | 551005<br>EAMC-42-50-12-19  | 2836865<br>EAMK-A-D50-64C   | 2733790<br>EADS-F-D50-100A  |
| 2256698<br>EAMM-A-D60-60G-S1  | 2256289<br>EAMF-A-64B-60G/H-S1  | 543424<br>EAMC-42-50-11-12  | 552160<br>EAMK-A-D60-64B  | 2253505<br>EADS-F-D60-60G/H   |
| 2256697<br>EAMM-A-D60-60H-S1  | 2256289<br>EAMF-A-64B-60G/H-S1  | 1455671<br>EAMC-42-50-12-14   | 552160<br>EAMK-A-D60-64B  | 2253505<br>EADS-F-D60-60G/H   |
| 2256699<br>EAMM-A-D60-70A-S1  | 529945<br>EAMF-A-64A/B-70A  | 543424<br>EAMC-42-50-11-12  | 552160<br>EAMK-A-D60-64B  | 8022145<br>EADS-F-D60-70A   |
| 8199481<br>EAMM-A-D60-80G-S1-G2   | –   | 8086049<br>EAMC-42-50-12-20-U   | –   | 8199482<br>EADS-F-D60-80G-G2  |
| 2218564<br>EAMM-A-D60-80P-S1  | 1977113<br>EAMF-A-64A/C-80P   | 551005<br>EAMC-42-50-12-19  | 551007<br>EAMK-A-D60-64C  | 2218523<br>EADS-F-D60-80P   |
| 1322188<br>EAMM-A-D60-87A-S1  | 533140<br>EAMF-A-64A/B-87A  | 543424<br>EAMC-42-50-11-12  | 552160<br>EAMK-A-D60-64B  | 1561536<br>EADS-F-D60-87A   |
| 8197490<br>EAMM-A-D60-100A-S1-G2  | –   | 8101555<br>EAMC-42-50-12-19-U   | –   | 8197396<br>EADS-F-D60-100A-G2   |
| 2946764<br>EAMM-A-D80-80G-S1  | 2933286<br>EAMF-A-77A-80G-S1  | 3181801<br>EAMC-56-58-19-20   | 1593627<br>EAMK-A-D80-77A   | 8022147<br>EADS-F-D80-80G   |
| 1600673<br>EAMM-A-D80-100A-S1   | 1593628<br>EAMF-A-77A-100A  | 1485673<br>EAMC-56-58-19-19   | 1593627<br>EAMK-A-D80-77A   | 1593617<br>EADS-F-D80-100A  |
| 8157274<br>EAMM-A-D80-150A-S1   | –   | 1485674<br>EAMC-56-58-19-24   | 8159894<br>EAMK-A-D80-150A  | 8162067<br>EADS-F-D80-150A  |
| 3356931<br>EAMM-A-D100-100A-S1  | 1593628<br>EAMF-A-77A-100A  | 1485674<br>EAMC-56-58-19-24   | 1593914<br>EAMK-A-D100-77A/B  | 3356966<br>EADS-F-D100-100A   |
| 2946765<br>EAMM-A-D100-120G-S1  | 2449380<br>EAMF-A-77B-120G-S1   | 3187895<br>EAMC-67-62-24-25   | 1593914<br>EAMK-A-D100-77A/B  | 8022148<br>EADS-F-D100-120G   |
| 8157276<br>EAMM-A-D100-150A-S1  | –   | 1451407<br>EAMC-67-62-24-24   | 8159895<br>EAMK-A-D100-150A   | 8162068<br>EADS-F-D100-150A   |

# Datasheet

## Dimensions (sample illustration)

Download CAD data → [www.festo.com](http://www.festo.com)

EGC-TB-...

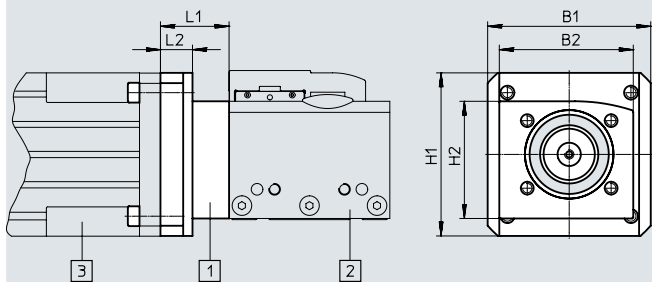

- Main illustration:  
 [1] Axial kit  
 [2] Toothed belt axis  
 [3] Motor

ELGA-...-TB

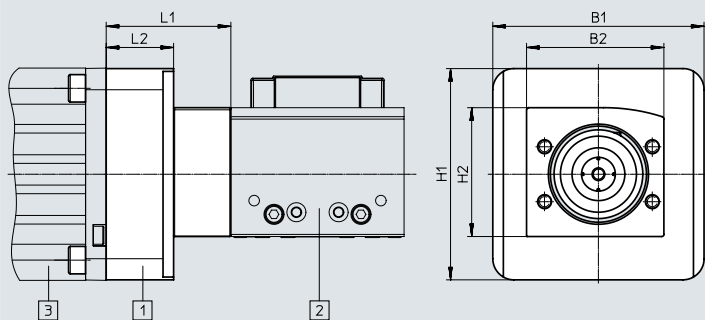

- Main illustration:  
 [1] Axial kit  
 [2] Toothed belt axis  
 [3] Motor

ELCC-TB-...

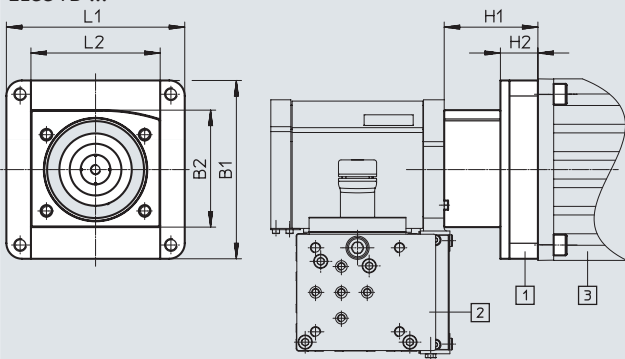

- Main illustration:  
 [1] Axial kit  
 [2] Cantilever axis  
 [3] Motor



## Datasheet

| Type               | B1   | B2   | H1   | H2   | L1   | L2   |
|--------------------|------|------|------|------|------|------|
| EAMM-A-L27-40A     | 40   | –    | 40   | –    | 18.1 | –    |
| EAMM-A-L27-40G     | 50   | 40   | 50   | 50   | 28.7 | –    |
| EAMM-A-L27-40R     | 40   | –    | 40   | –    | 27.1 | –    |
| EAMM-A-L27-40RA    | 40   | –    | 40   | –    | 20.1 | –    |
| EAMM-A-L27-42A     | 42.5 | 38   | 58   | 38   | 26.1 | 22.1 |
| EAMM-A-L27-50GA    | 55   | 55   | 55   | 39.5 | 26.6 | 21.6 |
| EAMM-A-L27-55A     | 55   | 40   | 55   | 55   | 23.1 | –    |
| EAMM-A-L27-57A     | 56   | 39.5 | 56   | 56   | 23.1 | –    |
| EAMM-A-L27-57AA    | 56   | 56   | 56   | 39.5 | 23.1 | 18.1 |
| EAMM-A-L27-57AB    | 56   | 56   | 56   | 39.5 | 23.1 | 18.1 |
| EAMM-A-L27-57AC    | 56   | 56   | 56   | 39.5 | 23.1 | 18.1 |
| EAMM-A-L27-58AA    | 55   | 55   | 55   | 39.5 | 22.1 | 17.1 |
| EAMM-A-L27-60G     | 60   | 60   | 60   | 39.5 | 37.1 | 32.1 |
| EAMM-A-L27-60RA    | 60   | 60   | 60   | 39.5 | 32.1 | 27.1 |
| EAMM-A-L27-60RB    | 60   | 60   | 60   | 39.5 | 25.1 | 20.1 |
| EAMM-A-L38-40G-G2  | 62   | 55   | 45   | 44   | 32   | 22   |
| EAMM-A-L38-50GA    | 55   | 57.5 | 55   | 50.3 | 30.4 | 14.7 |
| EAMM-A-L38-55A     | 55   | 57.5 | 55   | 50.3 | 26.7 | 11   |
| EAMM-A-L38-56GA    | 56   | 57.5 | 56   | 50.3 | 44.9 | 29.2 |
| EAMM-A-L38-57A-G2  | 56   | 55   | 56   | 45.6 | 26   | 14   |
| EAMM-A-L38-57AA    | 56   | 57.5 | 56   | 50.3 | 26.9 | 11.2 |
| EAMM-A-L38-58AA    | 55   | 57.5 | 55   | 50.3 | 25.9 | 10.2 |
| EAMM-A-L38-60AA    | 60   | 57.5 | 60   | 50.3 | 27.2 | 11.5 |
| EAMM-A-L38-60G-G2  | 62   | 55   | 62   | 45.6 | 41   | 28   |
| EAMM-A-L38-60H-G2  | 62   | 55   | 62   | 45.6 | 41   | 28   |
| EAMM-A-L38-60P-G2  | 62   | 55   | 62   | 45.6 | 36   | 20   |
| EAMM-A-L38-60PA    | 61.4 | 57.5 | 61.4 | 50.3 | 35.9 | 20.2 |
| EAMM-A-L38-60R-G2  | 62   | 55   | 62   | 45.6 | 36   | 20   |
| EAMM-A-L38-60RA    | 62   | 55   | 62   | 45.6 | 36   | 20   |
| EAMM-A-L38-60RB    | 61.4 | 57.5 | 61.4 | 50.3 | 28.9 | 13.2 |
| EAMM-A-L38-68GA    | 64   | 57.5 | 64   | 50.3 | 54.9 | 39.2 |
| EAMM-A-L38-70A     | 70   | 57.5 | 70   | 50.3 | 29.5 | 13.8 |
| EAMM-A-L38-70AA    | 70   | 57.5 | 70   | 50.3 | 35.9 | 20.2 |
| EAMM-A-L38-70GA-G2 | 85.8 | 55   | 85.8 | 45.6 | 42.5 | 37   |
| EAMM-A-L38-72GA    | 72   | 57.5 | 72   | 50.3 | 54.9 | 24   |
| EAMM-A-L38-84AA    | 96   | 57.5 | 96   | 50.3 | 45.9 | 30.2 |
| EAMM-A-L38-87A-G2  | 85.8 | 55   | 85.8 | 45.6 | 33   | 20   |
| EAMM-A-L38-88A     | 88   | 57.5 | 88   | 50.3 | 35.9 | 20.2 |
| EAMM-A-L48-40G     | 55   | 60   | 55   | 54   | 50.3 | 26.3 |
| EAMM-A-L48-50GA-G2 | 62   | 60   | 62   | 54   | 44.5 | 31.5 |
| EAMM-A-L48-55A     | 55   | 60   | 55   | 54   | 37.3 | 13.3 |
| EAMM-A-L48-56GA    | 56   | 65   | 56   | 52   | 56.3 | 32.3 |
| EAMM-A-L48-60G-G2  | 62   | 60   | 62   | 54   | 46   | 28   |
| EAMM-A-L48-60H-G2  | 62   | 60   | 62   | 54   | 46   | 28   |
| EAMM-A-L48-60P     | 62   | 60   | 62   | 54   | 41   | 20   |
| EAMM-A-L48-60PA    | 61.4 | 65   | 61.4 | 61   | 47.3 | 19.3 |
| EAMM-A-L48-68GA    | 64   | 65   | 64   | 61   | 65.3 | 37.3 |
| EAMM-A-L48-70A     | 70   | 65   | 70   | 61   | 40.2 | 12.2 |
| EAMM-A-L48-70AA    | 70   | 65   | 70   | 61   | 47.3 | 19.3 |
| EAMM-A-L48-70GA-G2 | 85.8 | 62   | 85.8 | 59   | 53.3 | 37   |
| EAMM-A-L48-72GA    | 72   | 65   | 72   | 61   | 65.3 | 37.3 |
| EAMM-A-L48-75GA    | 75   | 60   | 75   | 54   | 74.4 | 50.4 |

# Datasheet

**Dimensions (sample illustration)**

Download CAD data → [www.festo.com](http://www.festo.com)

EGC-TB-...

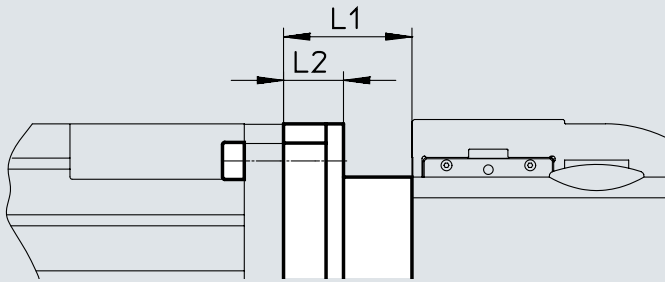

- Main illustration:  
 [1] Axial kit  
 [2] Toothed belt axis  
 [3] Motor

ELGA-...-TB

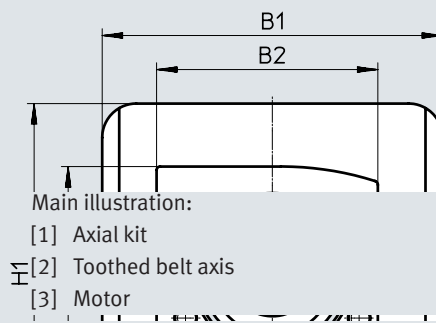
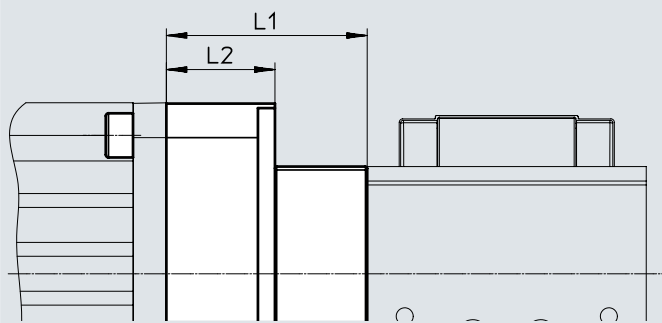

- Main illustration:  
 [1] Axial kit  
 [2] Toothed belt axis  
 [3] Motor

ELCC-TB-...

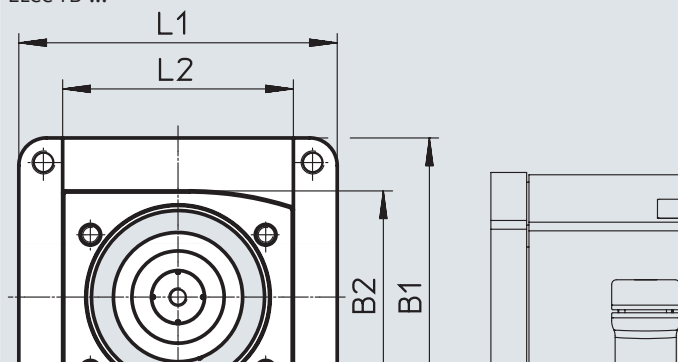

- Main illustration:  
 [1] Axial kit  
 [2] Cantilever axis  
 [3] Motor

## Datasheet

| Type               | B1   | B2  | H1    | H2   | L1    | L2   |
|--------------------|------|-----|-------|------|-------|------|
| EAMM-A-L48-80G-G2  | 82   | 60  | 82    | 54   | 59    | 29   |
| EAMM-A-L48-80P-G2  | 82   | 65  | 82    | 54   | 54    | 21   |
| EAMM-A-L48-80PB    | 82   | 60  | 82    | 54   | 54    | 21   |
| EAMM-A-L48-82AA    | 82   | 65  | 82    | 61   | 47.3  | 19.3 |
| EAMM-A-L48-84AA    | 96   | 65  | 96    | 61   | 58.4  | 30.4 |
| EAMM-A-L48-87A-G2  | 85.8 | 60  | 85.8  | 54   | 44    | 20   |
| EAMM-A-L48-88A     | 88   | 65  | 88    | 61   | 47.3  | 19.3 |
| EAMM-A-L48-90GA    | 92   | 65  | 92    | 61   | 64.4  | 36.4 |
| EAMM-A-L48-90R     | 90   | 65  | 90    | 61   | 52.3  | 24.3 |
| EAMM-A-L48-92RA    | 90   | 65  | 90    | 61   | 57.3  | 29.3 |
| EAMM-A-L48-100A-G2 | 104  | 60  | 104   | 54   | 59    | 24   |
| EAMM-A-L48-120GA   | 90   | 65  | 90    | 61   | 58.4  | 30.4 |
| EAMM-A-L62-56GA    | 80   | 80  | 68    | 68   | 60.9  | –    |
| EAMM-A-L62-60H     | 68   | 68  | 68    | 68   | 56.9  | –    |
| EAMM-A-L62-68GA    | 92   | 92  | 66    | 75   | 69.9  | 37.9 |
| EAMM-A-L62-72GA    | 92   | 92  | 72    | 75   | 69.9  | 37.9 |
| EAMM-A-L62-70GA    | 76   | 76  | 72    | 72   | 56.4  | –    |
| EAMM-A-L62-75GA    | 92   | 92  | 75    | 75   | 77.9  | –    |
| EAMM-A-L62-80G-G2  | 104  | 92  | 104   | 79   | 62.5  | 34   |
| EAMM-A-L62-84AA    | 96   | 80  | 96    | 70   | 61.9  | 25.9 |
| EAMM-A-L62-88A     | 88   | 80  | 88    | 70   | 51.9  | 19.9 |
| EAMM-A-L62-90GA    | 92   | 92  | 92    | 75   | 67.9  | 35.9 |
| EAMM-A-L62-100A-G2 | 104  | 92  | 104   | 79   | 62.5  | 24   |
| EAMM-A-L62-108AA   | 114  | 100 | 114   | 90.5 | 75.5  | 27.5 |
| EAMM-A-L62-115GA   | 138  | 92  | 102   | 75   | 109.9 | 62.9 |
| EAMM-A-L62-120G    | 120  | 92  | 120   | 75   | 76.9  | 54.9 |
| EAMM-A-L62-120GA   | 92   | 92  | 92    | 75   | 61.9  | 29.9 |
| EAMM-A-L62-120GB   | 120  | 92  | 120   | 75   | 71.9  | 15.9 |
| EAMM-A-L62-120GC   | 132  | 92  | 132   | 75   | 91.9  | 22.9 |
| EAMM-A-L62-150A    | 151  | 100 | 151   | 79   | 72.5  | 30   |
| EAMM-A-L95-75GA    | 138  | 140 | 102   | 120  | 81.4  | 32.4 |
| EAMM-A-L95-68GA    | 138  | 140 | 102   | 120  | 73.4  | 24.4 |
| EAMM-A-L95-72GA    | 138  | 140 | 102   | 120  | 73.4  | 24.4 |
| EAMM-A-L95-80G-G2  | 140  | 140 | 106.4 | 120  | 66    | 17   |
| EAMM-A-L95-90GA    | 138  | 140 | 102   | 120  | 71.4  | 22.4 |
| EAMM-A-L95-115GA   | 138  | 138 | 102   | 102  | 113.4 | –    |
| EAMM-A-L95-120G-G2 | 114  | 140 | 114   | 120  | 81    | 32   |
| EAMM-A-L95-120GA   | 138  | 140 | 102   | 120  | 65.4  | 16.4 |
| EAMM-A-L95-120GB   | 138  | 140 | 122   | 120  | 75.4  | 26.4 |
| EAMM-A-L95-120GC   | 138  | 138 | 124   | 102  | 95.4  | 21.4 |
| EAMM-A-L95-150A-G2 | 151  | 140 | 151   | 120  | 76    | 27   |
| EAMM-A-L95-160G-G2 | 190  | 140 | 190   | 120  | 112   | 72   |
| EAMM-A-L95-190A-G2 | 190  | 140 | 190   | 120  | 86    | 37   |
| EAMM-A-L95-190B-G2 | 190  | 140 | 190   | 120  | 85    | 36   |

# Datasheet

**Dimensions (sample illustration)**

Download CAD data → [www.festo.com](http://www.festo.com)

EGC-TB-...

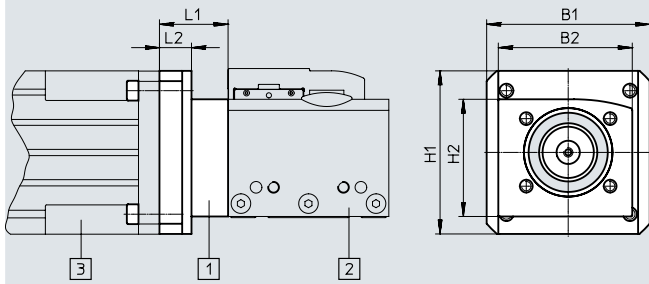

- Main illustration:  
 [1] Axial kit  
 [2] Toothed belt axis  
 [3] Motor

ELGA-...-TB

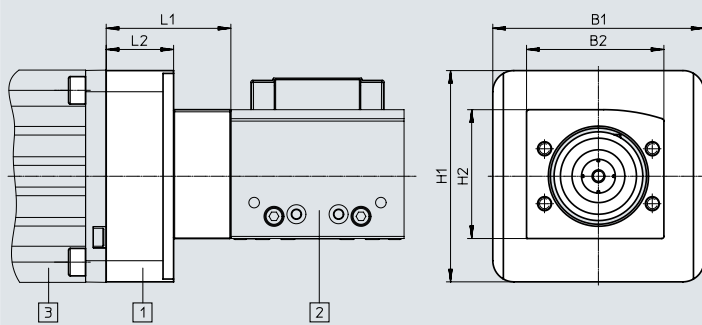

- Main illustration:  
 [1] Axial kit  
 [2] Toothed belt axis  
 [3] Motor

ELCC-TB-...

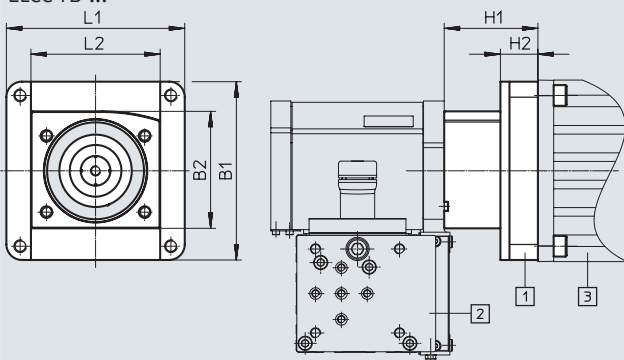



- Main illustration:  
 [1] Axial kit  
 [2] Cantilever axis  
 [3] Motor

## Datasheet

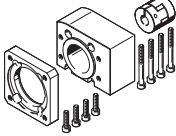
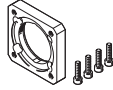
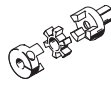

| Type               | B1   | B2   | H1   | H2   | L1    | L2   |
|--------------------|------|------|------|------|-------|------|
| EAMM-A-N38-40G     | 58   | 56   | 55   | 50   | 40.3  | 38.3 |
| EAMM-A-N38-50GA    | 58   | 56   | 55   | 50   | 38.8  | 36.8 |
| EAMM-A-N38-56GA    | 60   | 56   | 56   | 50   | 53.4  | 51.4 |
| EAMM-A-N38-60G-G2  | 62   | 55   | 62   | 48.6 | 41    | 28   |
| EAMM-A-N38-60H-G2  | 62   | 55   | 62   | 48.6 | 41    | 28   |
| EAMM-A-N38-60P     | 62   | 55   | 62   | 48.6 | 36    | 20   |
| EAMM-A-N38-60PA    | 61.4 | 56   | 61.4 | 50   | 44.4  | 32.4 |
| EAMM-A-N38-60RA    | 61.4 | 56   | 61.4 | 50   | 44.4  | 32.4 |
| EAMM-A-N38-90R     | 90   | 56   | 90   | 50   | 49.4  | 37.4 |
| EAMM-A-N38-92RA    | 90   | 56   | 90   | 50   | 54.4  | 42.4 |
| EAMM-A-N38-70GA    | 74   | 55   | 74   | 48.6 | 50.4  | 48.4 |
| EAMM-A-N38-68GA    | 64   | 56   | 64   | 50   | 62.4  | 50.4 |
| EAMM-A-N38-70A     | 70   | 57.5 | 70   | 50.3 | 37.5  | 21   |
| EAMM-A-N38-70AA    | 70   | 56   | 70   | 50   | 44.4  | 32.4 |
| EAMM-A-N38-72GA    | 72   | 56   | 72   | 50   | 62.4  | 50.4 |
| EAMM-A-N38-87A     | 85.5 | 57.5 | 85.5 | 50.3 | 42    | 25.5 |
| EAMM-A-N38-88A     | 88   | 56   | 88   | 50   | 44.4  | 32.4 |
| EAMM-A-N48-40G     | 64   | 62   | 62   | 59   | 42    | 28   |
| EAMM-A-N48-50GA    | 68   | 65   | 58   | 56   | 43    | 29   |
| EAMM-A-N48-56GA    | 68   | 65   | 58   | 56   | 57.5  | 53.5 |
| EAMM-A-N48-60G-G2  | 64   | 62   | 62   | 59   | 46    | 28   |
| EAMM-A-N48-60H-G2  | 64   | 62   | 62   | 59   | 46    | 28   |
| EAMM-A-N48-60P     | 64   | 62   | 62   | 59   | 41    | 20   |
| EAMM-A-N48-60PA    | 66   | 65   | 66   | 56   | 48.5  | 34.5 |
| EAMM-A-N48-68GA    | 68   | 65   | 68   | 56   | 66.5  | 35.5 |
| EAMM-A-N48-70AA    | 70   | 65   | 70   | 56   | 48.5  | 34.5 |
| EAMM-A-N48-70GA-G2 | 85.8 | 62   | 85.8 | 59   | 53.5  | 37   |
| EAMM-A-N48-72GA    | 72   | 65   | 72   | 56   | 66.5  | 35.5 |
| EAMM-A-N48-75GA    | 75   | 65   | 75   | 56   | 74.5  | 43.5 |
| EAMM-A-N48-80G-G2  | 82   | 62   | 82   | 59   | 59    | 29   |
| EAMM-A-N48-80P     | 82   | 62   | 82   | 59   | 54    | 21   |
| EAMM-A-N48-80PB    | 82   | 62   | 82   | 59   | 54    | 21   |
| EAMM-A-N48-84AA    | 96   | 65   | 96   | 56   | 58.5  | 44.5 |
| EAMM-A-N48-88A     | 88   | 65   | 88   | 56   | 48.5  | 34.5 |
| EAMM-A-N48-87A     | 85.8 | 62   | 85.8 | 59   | 44    | 20   |
| EAMM-A-N48-90GA    | 93   | 62   | 93   | 59   | 64.5  | 60.5 |
| EAMM-A-N48-90GB    | 132  | 65   | 92   | 75   | 54.5  | 34   |
| EAMM-A-N48-100A-G2 | 104  | 62   | 104  | 59   | 59    | 24   |
| EAMM-A-N48-120GA   | 90   | 65   | 90   | 56   | 58.5  | 44.5 |
| EAMM-A-N80-68GA    | 96   | 92   | 96   | 82   | 70    | 24.5 |
| EAMM-A-N80-72GA    | 96   | 92   | 96   | 82   | 70    | 26.5 |
| EAMM-A-N80-70GA    | 96   | 92   | 96   | 82   | 58    | 44   |
| EAMM-A-N80-75GA    | 96   | 92   | 96   | 82   | 78.5  | 64.5 |
| EAMM-A-N80-80G-G2  | 104  | 92   | 104  | 82   | 62.5  | 58.5 |
| EAMM-A-N80-84AA    | 96   | 92   | 96   | 82   | 62.5  | 48.5 |
| EAMM-A-N80-90GA    | 116  | 92   | 96   | 82   | 68.5  | 54.5 |
| EAMM-A-N80-90GB    | 124  | 92   | 96   | 82   | 60.5  | 52.5 |
| EAMM-A-N80-100A    | 100  | 92   | 100  | 82   | 62.5  | 48.5 |
| EAMM-A-N80-115GA   | 116  | 92   | 102  | 82   | 110.5 | 65   |
| EAMM-A-N80-120G    | 124  | 100  | 124  | 90.5 | 77.5  | 34   |
| EAMM-A-N80-120GA   | 140  | 92   | 102  | 82   | 62.5  | 60.5 |
| EAMM-A-N80-120GB   | 140  | 92   | 122  | 82   | 82.5  | 37   |
| EAMM-A-N80-120GC   | 140  | 92   | 124  | 82   | 92.5  | 47   |
| EAMM-A-N80-150A    | 151  | 100  | 151  | 90   | 72.5  | 30   |

## Datasheet

## Ordering data – Individual components

| Axial kit   | Consisting of:  |   |   |   |
|---|---|---|---|---|
|   | Motor flange  | Coupling  | Coupling housing  | Screw kit   |
|  |  |  |  |  |
| Part no.<br>Type  | Part no.<br>Type  | Part no.<br>Type  | Part no.<br>Type  | Part no.<br>Type  |
| 557974<br>EAMM-A-L27-40G  | 558015<br>EAMF-A-L27-40G  | 557998<br>EAMD-19-15-10-8X10  | –   | –   |
| 557975<br>EAMM-A-L27-55A  | 558016<br>EAMF-A-L27-55A  | 557999<br>EAMD-19-15-9-8X10   | –   | –   |
| 560678<br>EAMM-A-L27-57A  | 560690<br>EAMF-A-L27-57A  | 561292<br>EAMD-16-15-6.35-8X10  | –   | –   |
| 3683331<br>EAMM-A-L38-55A   | 558176<br>EAMF-A-38A-55A  | 3717923<br>EAMD-25-22-9-10X12   | 558011<br>EAMK-A-L38-38A  | 567484<br>EAHM-L2-M5-30   |
| 8197461<br>EAMM-A-L38-57A-G2  | –   | 561293<br>EAMD-25-22-6.35-10X12   | –   | –   |
| 8197460<br>EAMM-A-L38-60G-G2  | –   | 558000<br>EAMD-25-22-11-10X12   | –   | –   |
| 8197452<br>EAMM-A-L38-60H-G2  | –   | 1453861<br>EAMD-28-22-14-10X12  | –   | –   |
| 8197454<br>EAMM-A-L38-60P-G2  | –   | 1453861<br>EAMD-28-22-14-10X12  | –   | –   |
| 557979<br>EAMM-A-L38-70A  | 558018<br>EAMF-A-38A-70A  | 558000<br>EAMD-25-22-11-10X12   | 558011<br>EAMK-A-L38-38A  | 567484<br>EAHM-L2-M5-30   |
| 8197447<br>EAMM-A-L38-87A-G2  | –   | 558000<br>EAMD-25-22-11-10X12   | –   | –   |
| 8197457<br>EAMM-A-L48-60G-G2  | –   | 8203729<br>EAMD-42-40-11-16X25-U  | –   | –   |
| 8197458<br>EAMM-A-L48-60H-G2  | –   | 3420022<br>EAMD-42-40-14-16X25-U  | –   | –   |
| 557982<br>EAMM-A-L48-70A  | 558025<br>EAMF-A-48A-70A  | 558001<br>EAMD-32-32-11-16X20   | 558012<br>EAMK-A-L48-48A  | 567486<br>EAHM-L2-M5-40   |
| 8197459<br>EAMM-A-L48-87A-G2  | –   | 558001<br>EAMD-32-32-11-16X20   | –   | –   |
| 8197456<br>EAMM-A-L62-80G-G2  | –   | 8165049<br>EAMD-56-46-20-23X27-U  | –   | –   |
| 8157270<br>EAMM-A-L62-150A  | –   | 558005<br>EAMD-56-46-24-23X27   | 8159893<br>EAMK-A-L62-150A  | –   |
| 3660191<br>EAMM-A-L95-80G-G2  | –   | 3717812<br>EAMD-67-51-20-32X32-U  | 3712650<br>EAMK-A-L95-95A/B-G2  | –   |
| 3659941<br>EAMM-A-L95-120G-G2   | 3659724<br>EAMF-A-95A-120G-G2   | 558006<br>EAMD-67-51-25-32X32-U   | 3712650<br>EAMK-A-L95-95A/B-G2  | 567496<br>EAHM-L2-M8-70   |
| 8157280<br>EAMM-A-L95-150A-G2   | 8157268<br>EAMF-A-95A-150A  | 558008<br>EAMD-67-51-24-32X32-U   | 3712650<br>EAMK-A-L95-95A/B-G2  | 1201751<br>EAHM-L5-M8-75  |
| 3659562<br>EAMM-A-L95-190A-G2   | –   | 1379269<br>EAMD-67-51-32-32X32-U  | 3712650<br>EAMK-A-L95-95A/B-G2  | 567497<br>EAHM-L2-M8-80   |
| 8157282<br>EAMM-A-L95-190B-G2   | 8157269<br>EAMF-A-95A-190B  | 8196716<br>EAMD-67-65-32-32X32-U  | 3712650<br>EAMK-A-L95-95A/B-G2  | 567497<br>EAHM-L2-M8-80   |

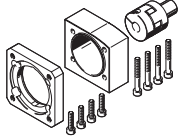
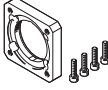
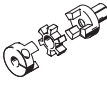
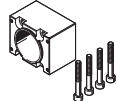
## Datasheet

| Ordering data – Individual components   |   |   |   |   |
|---|---|---|---|---|
| Axial kit   | Consisting of:  |   |   |   |
|   | Motor flange  | Coupling  | Coupling housing  | Screw kit   |
|  |  |  |  |  |
| Part no.<br>Type  | Part no.<br>Type  | Part no.<br>Type  | Part no.<br>Type  | Part no.<br>Type  |
| 8197462<br>EAMM-A-N38-60G-G2  | –   | 8086050<br>EAMD-32-32-11-16X20-U  | –   | –   |
| 8197463<br>EAMM-A-N38-60H-G2  | –   | 8086051<br>EAMD-32-32-14-16X20-U  | –   | –   |
| 1202331<br>EAMM-A-N38-70A   | 1202337<br>EAMF-A-38D-70A   | 558001<br>EAMD-32-32-11-16X20   | 1345947<br>EAMK-A-N38-38D   | 1202288<br>EAHM-L5-M6-35  |
| 3324111<br>EAMM-A-N38-87A   | 3319868<br>EAMF-A-38D-87A   | 558001<br>EAMD-32-32-11-16X20   | 1345947<br>EAMK-A-N38-38D   | 1202288<br>EAHM-L5-M6-35  |
| 8197469<br>EAMM-A-N48-60G-G2  | –   | 203729<br>EAMD-42-40-11-16X25-U   | –   | –   |
| 8197465<br>EAMM-A-N48-60H-G2  | –   | 3420022<br>EAMD-42-40-14-16X25-U  | –   | –   |
| 8197470<br>EAMM-A-N48-80G-G2  | –   | 1781043<br>EAMD-42-40-20-16X25-U  | –   | –   |
| 8063592<br>EAMM-A-N48-80P   | –   | 8121127<br>EAMD-42-48-19-16X25  | –   | –   |
| 8197464<br>EAMM-A-N48-100A-G2   | –   | 558002<br>EAMD-42-40-19-16X25   | –   | –   |
| 8197471<br>EAMM-A-N80-80G-G2  | –   | 8165049<br>EAMD-56-46-20-23X27-U  | –   | –   |
| 1201695<br>EAMM-A-N80-120G  | 1190702<br>EAMF-A-80A-120G  | 1188801<br>EAMD-56-46-25-23X27  | 1345953<br>EAMK-A-N80-80A   | 1201712<br>EAHM-L5-M8-60  |
| 8157277<br>EAMM-A-N80-150A  | –   | 558005<br>EAMD-56-46-24-23X27   | 8159896<br>EAMK-A-N80-150A  | –   |

# Datasheet

**Dimensions (sample illustration)**

Download CAD data → [www.festo.com](http://www.festo.com)

EGC-BS-...

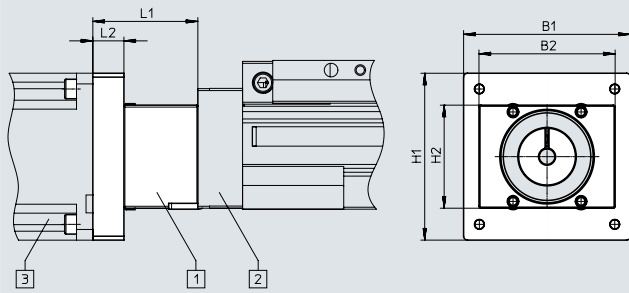

- Main illustration:  
 [1] Axial kit  
 [2] Ball screw axis  
 [3] Motor

ELGA-BS-...-

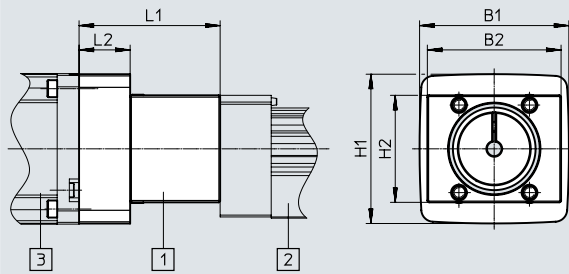

- Main illustration:  
 [1] Axial kit  
 [2] Ball screw axis  
 [3] Motor

EGC-HD-BS-...

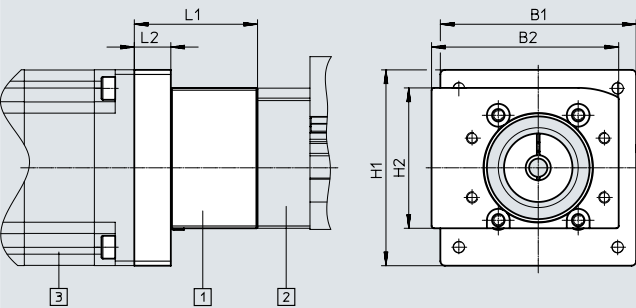



- Main illustration:  
 [1] Axial kit  
 [2] Ball screw axis  
 [3] Motor



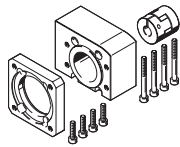
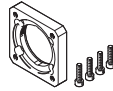
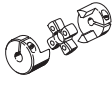
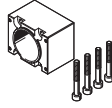

## Datasheet

| Type               | B1   | B2  | H1    | H2  | L1    | L2   |
|--------------------|------|-----|-------|-----|-------|------|
| EAMM-A-S38-40A-G2  | 58   | 55  | 44    | 44  | 44    | 7    |
| EAMM-A-S38-40G-G2  | 60   | 55  | 60    | 44  | 54    | 17   |
| EAMM-A-S38-40P-G2  | 58   | 55  | 44    | 44  | 44.7  | 10.7 |
| EAMM-A-S38-42A-G2  | 58   | 55  | 44    | 44  | 52    | 15   |
| EAMM-A-S38-50GA    | 62   | 55  | 62    | 44  | 60.3  | 23.3 |
| EAMM-A-S38-55A-G3  | 55   | 44  | 55    | 44  | 47    | 16   |
| EAMM-A-S38-57A-G2  | 56   | 55  | 56    | 44  | 48    | 11   |
| EAMM-A-S38-58AA    | 58   | 55  | 58    | 44  | 47.6  | 10.6 |
| EAMM-A-S38-60AA    | 60   | 55  | 60    | 44  | 48.5  | 11.5 |
| EAMM-A-S38-60R-G2  | 62   | 44  | 62    | 44  | 49    | 20   |
| EAMM-A-S38-60RA-G2 | 62   | 44  | 62    | 44  | 49    | 20   |
| EAMM-A-S38-60P-G3  | 62   | 44  | 62    | 44  | 49    | 20   |
| EAMM-A-S48-40G-G2  | 60   | 70  | 60    | 53  | 55    | 17   |
| EAMM-A-S48-50GA    | 70   | 70  | 54    | 53  | 52    | 14   |
| EAMM-A-S48-55A-G2  | 70   | 70  | 55    | 53  | 47.2  | 9.2  |
| EAMM-A-S48-57A-G2  | 70   | 70  | 55    | 53  | 47.2  | 9.2  |
| EAMM-A-S48-58AA    | 70   | 70  | 58    | 53  | 47.2  | 9.2  |
| EAMM-A-S48-60AA    | 60   | 70  | 60    | 53  | 48.5  | 10.5 |
| EAMM-A-S48-60G-G3  | 62   | 53  | 62    | 53  | 55.5  | 28   |
| EAMM-A-S48-60H-G3  | 62   | 53  | 62    | 53  | 55.5  | 28   |
| EAMM-A-S48-60P-G3  | 62   | 53  | 62    | 53  | 50.5  | 20   |
| EAMM-A-S48-60R-G2  | 62   | 53  | 62    | 53  | 50.5  | 20   |
| EAMM-A-S48-60RA-G2 | 62   | 53  | 62    | 53  | 50.5  | 20   |
| EAMM-A-S48-70A-G2  | 70   | 70  | 70    | 53  | 50.2  | 12.2 |
| EAMM-A-S48-70AA    | 70   | 70  | 70    | 53  | 57.3  | 19.3 |
| EAMM-A-S48-80P     | 82   | 53  | 82    | 53  | 72    | 21   |
| EAMM-A-S48-80PB    | 82   | 53  | 82    | 53  | 72    | 21   |
| EAMM-A-S48-87A-G2  | 85.8 | 70  | 85.8  | 53  | 54    | 16   |
| EAMM-A-S62-60G-G2  | 80   | 80  | 80    | 70  | 84.5  | 18   |
| EAMM-A-S62-60H-G2  | 80   | 80  | 80    | 70  | 84.5  | 18   |
| EAMM-A-S62-70A-G2  | 82   | 80  | 70    | 70  | 78.5  | 12   |
| EAMM-A-S62-70GA    | 82   | 80  | 82    | 70  | 79.5  | 13   |
| EAMM-A-S62-80G-G3  | 104  | 80  | 104   | 70  | 90    | 34   |
| EAMM-A-S62-80P-G2  | 82   | 80  | 82    | 70  | 77    | 10.5 |
| EAMM-A-S62-80PB    | 82   | 80  | 82    | 70  | 77    | 10.5 |
| EAMM-A-S62-82AA    | 82   | 80  | 82    | 70  | 79    | 12.5 |
| EAMM-A-S62-84AA    | 84   | 80  | 84    | 70  | 81    | 14.5 |
| EAMM-A-S62-87A-G2  | 85.8 | 80  | 85.8  | 70  | 81.5  | 15   |
| EAMM-A-S62-100A-G3 | 104  | 80  | 104   | 70  | 80    | 24   |
| EAMM-A-S62-150A-G2 | 151  | 80  | 151   | 70  | 91    | 24.5 |
| EAMM-A-S95-80G     | 140  | 140 | 106.4 | 110 | 85.5  | 17   |
| EAMM-A-S95-84AA    | 140  | 140 | 110   | 110 | 85.5  | 17   |
| EAMM-A-S95-90GA    | 140  | 140 | 110   | 110 | 94    | 21.9 |
| EAMM-A-S95-100A-G2 | 140  | 140 | 100   | 110 | 85.5  | 17   |
| EAMM-A-S95-120G    | 151  | 140 | 151   | 110 | 109.5 | 44   |
| EAMM-A-S95-150A-G2 | 151  | 140 | 151   | 110 | 95.5  | 30   |

## Datasheet

| Ordering data – Individual components   |   |   |   |   |
|---|---|---|---|---|
| Axial kit   | Consisting of:  |   |   |   |
|   | Motor flange  | Coupling  | Coupling housing  | Screw kit   |
|  |  |  |  |  |
| Part no.<br>Type  | Part no.<br>Type  | Part no.<br>Type  | Part no.<br>Type  | Part no.<br>Type  |
| 3637971<br>EAMM-A-S38-40A-G2  | 558175<br>EAMF-A-38B-40A  | 558312<br>EAMC-30-32-6-6  | 3637942<br>EAMK-A-S38-38A/B-G2  | –   |
| 1456647<br>EAMM-A-S38-40G-G2  | 1460097<br>EAMF-A-38A-40G   | 562681<br>EAMC-30-32-6-10   | 3637942<br>EAMK-A-S38-38A/B-G2  | 567488<br>EAHM-L2-M5-50   |
| 3637972<br>EAMM-A-S38-40P-G2  | 2219077<br>EAMF-A-38B-40P   | 533708<br>EAMC-30-32-6-8  | 3637942<br>EAMK-A-S38-38A/B-G2  | –   |
| 3637965<br>EAMM-A-S38-42A-G2  | 560691<br>EAMF-A-38B-42A  | 561333<br>EAMC-30-32-5-6  | 3637942<br>EAMK-A-S38-38A/B-G2  | –   |
| 8197483<br>EAMM-A-S38-55A-G3  | –   | 551003<br>EAMC-30-32-6-9  | –   | –   |
| 3637956<br>EAMM-A-S38-57A-G2  | 560692<br>EAMF-A-38A-57A  | 551002<br>EAMC-30-32-6-6.35   | 3637942<br>EAMK-A-S38-38A/B-G2  | 567488<br>EAHM-L2-M5-50   |
| 8197479<br>EAMM-A-S38-60P-G3  | –   | 1233256<br>EAMC-30-32-6-14  | –   | –   |
| 1456650<br>EAMM-A-S48-40G-G2  | 4067069<br>EAMF-A-48B-40G   | 558029<br>EAMC-30-32-8-10   | 3637941<br>EAMK-A-S48-48A/B-G2  | –   |
| 3637961<br>EAMM-A-S48-55A-G2  | 558177<br>EAMF-A-48B-55A  | 543423<br>EAMC-30-32-8-9  | 3637941<br>EAMK-A-S48-48A/B-G2  | –   |
| 3637963<br>EAMM-A-S48-57A-G2  | 560694<br>EAMF-A-48B-57A  | 543421<br>EAMC-30-32-6.35-8   | 3637941<br>EAMK-A-S48-48A/B-G2  | –   |
| 8197477<br>EAMM-A-S48-60G-G3  | –   | 551004<br>EAMC-30-32-8-11   | –   | –   |
| 8197482<br>EAMM-A-S48-60H-G3  | –   | 562682<br>EAMC-30-32-8-14   | –   | –   |
| 8197481<br>EAMM-A-S48-60P-G3  | –   | 562682<br>EAMC-30-32-8-14   | –   | –   |

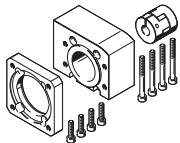
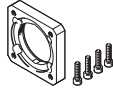
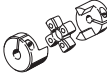
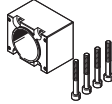
## Datasheet

| Ordering data – Individual components   |   |   |   |   |
|---|---|---|---|---|
| Axial kit   | Consisting of:  |   |   |   |
|   | Motor flange  | Coupling  | Coupling housing  | Screw kit   |
|  |  |  |  |  |
| Part no.<br>Type  | Part no.<br>Type  | Part no.<br>Type  | Part no.<br>Type  | Part no.<br>Type  |
| 3637957<br>EAMM-A-S48-70A-G2  | 558025<br>EAMF-A-48A-70A  | 551004<br>EAMC-30-32-8-11   | 3637941<br>EAMK-A-S48-48A/B-G2  | 567488<br>EAHM-L2-M5-50   |
| 3637962<br>EAMM-A-S48-87A-G2  | 560695<br>EAMF-A-48A-87A  | 551004<br>EAMC-30-32-8-11   | 3637941<br>EAMK-A-S48-48A/B-G2  | 567489<br>EAHM-L2-M5-55   |
| 2297649<br>EAMM-A-S62-60G-G2  | 1460112<br>EAMF-A-62A-60G/H   | 525864<br>EAMC-40-66-11-12  | 3637940<br>EAMK-A-S62-62A/B-G2  | 567495<br>EAHM-L2-M6-90   |
| 1456654<br>EAMM-A-S62-60H-G2  | 1460112<br>EAMF-A-62A-60G/H   | 1452803<br>EAMC-40-66-12-14   | 3637940<br>EAMK-A-S62-62A/B-G2  | 567495<br>EAHM-L2-M6-90   |
| 3637959<br>EAMM-A-S62-70A-G2  | 558179<br>EAMF-A-62B-70A  | 558313<br>EAMC-42-66-11-12  | 3637940<br>EAMK-A-S62-62A/B-G2  | –   |
| 8197473<br>EAMM-A-S62-80G-G3  | –   | 8086049<br>EAMC-42-50-12-20-U   | –   | –   |
| 3637970<br>EAMM-A-S62-80P-G2  | 2222624<br>EAMF-A-62B-80P   | 551005<br>EAMC-42-50-12-19  | 3637940<br>EAMK-A-S62-62A/B-G2  | –   |
| 3637966<br>EAMM-A-S62-87A-G2  | 560696<br>EAMF-A-62B-87A  | 558313<br>EAMC-42-66-11-12  | 3637940<br>EAMK-A-S62-62A/B-G2  | –   |
| 8197486<br>EAMM-A-S62-100A-G3   | –   | 551005<br>EAMC-42-50-12-19  | –   | –   |
| 8157272<br>EAMM-A-S62-150A-G2   | 8156626<br>EAMF-A-62A-150A  | 558314<br>EAMC-42-50-12-24  | 3637940<br>EAMK-A-S62-62A/B-G2  | 567495<br>EAHM-L2-M6-90   |
| 3637955<br>EAMM-A-S95-100A-G2   | 558182<br>EAMF-A-95B-100A   | 558315<br>EAMC-56-58-19-25  | 3637939<br>EAMK-A-S95-95A/B-G2  | –   |
| 8157279<br>EAMM-A-S95-150A-G2   | –   | 558316<br>EAMC-56-58-24-25  | 8160697<br>EAMK-A-S95-150A  | –   |

Datasheet

Dimensions (sample illustration)

Download CAD data → [www.festo.com](http://www.festo.com)

EGC-HD-TB-...

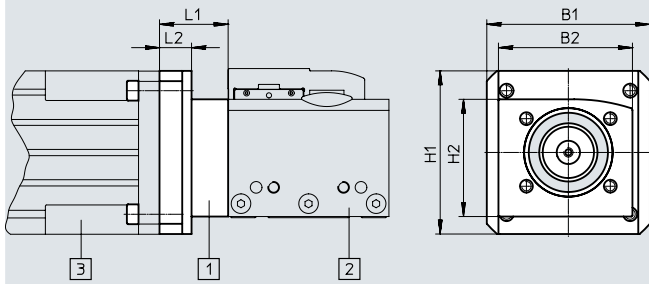

- Main illustration:  
 [1] Axial kit  
 [2] Toothed belt axis  
 [3] Motor

| Type             | B1  | B2 | H1  | H2   | L1   | L2   |
|------------------|-----|----|-----|------|------|------|
| EAMM-A-M43-40G   | 58  | 56 | 55  | 50   | 23.8 | 21.8 |
| EAMM-A-M43-50GA  | 58  | 56 | 55  | 50   | 22.3 | 20.3 |
| EAMM-A-M43-55A   | 58  | 56 | 55  | 50   | 17.8 | 15.8 |
| EAMM-A-M43-56GA  | 60  | 56 | 56  | 50   | 36.9 | 34.9 |
| EAMM-A-M43-60G   | 60  | –  | 60  | –    | 33   | –    |
| EAMM-A-M43-60H   | 60  | –  | 60  | –    | 33   | –    |
| EAMM-A-M43-68GA  | 64  | 55 | 64  | 49.4 | 45.9 | 33.9 |
| EAMM-A-M43-70GA  | 74  | 55 | 74  | 49.4 | 33.9 | 31.9 |
| EAMM-A-M43-72GA  | 72  | 56 | 72  | 50   | 45.9 | 33.9 |
| EAMM-A-M43-70A   | 70  | 56 | 70  | 50   | 20.9 | 18.9 |
| EAMM-A-M43-70AA  | 70  | 56 | 70  | 50   | 27.9 | 15.9 |
| EAMM-A-M43-90R   | 90  | 56 | 90  | 50   | 32.9 | 20.9 |
| EAMM-A-M43-92RA  | 90  | 56 | 90  | 50   | 37.9 | 25.9 |
| EAMM-A-M48-40G   | 68  | –  | 60  | –    | 17.5 | –    |
| EAMM-A-M48-50GA  | 68  | –  | 58  | –    | 16   | –    |
| EAMM-A-M48-56GA  | 68  | 65 | 58  | 56   | 30.5 | 26.5 |
| EAMM-A-M48-60H   | 66  | –  | 60  | –    | 26   | –    |
| EAMM-A-M48-60G   | 65  | 65 | 60  | 56   | 26.5 | 22.5 |
| EAMM-A-M48-68GA  | 68  | 65 | 68  | 56   | 39.5 | 35.5 |
| EAMM-A-M48-70GA  | 74  | 65 | 74  | 54   | 27.5 | 23.5 |
| EAMM-A-M48-72GA  | 72  | 65 | 72  | 56   | 39.5 | 35.5 |
| EAMM-A-M48-75GA  | 75  | 65 | 75  | 56   | 47.5 | 43.5 |
| EAMM-A-M48-88A   | 88  | 65 | 88  | 56   | 21.5 | 17.5 |
| EAMM-A-M48-84AA  | 96  | 65 | 96  | 56   | 31.5 | 27.5 |
| EAMM-A-M48-80G   | 100 | –  | 100 | –    | 32   | –    |
| EAMM-A-M48-90GA  | 93  | 65 | 93  | 56   | 37.5 | 33.5 |
| EAMM-A-M48-90GB  | 132 | 64 | 94  | 52   | 31.5 | 31   |
| EAMM-A-M48-120GA | 90  | 65 | 90  | 56   | 31.5 | 27.5 |

# Datasheet

## Dimensions (sample illustration)

Download CAD data → [www.festo.com](http://www.festo.com)

EGC-HD-TB-...

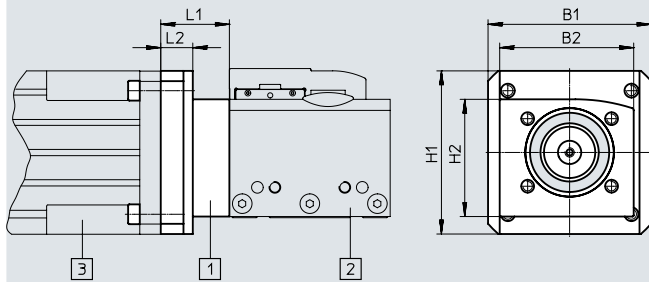

Main illustration:  
 [1] Axial kit  
 [2] Toothed belt axis  
 [3] Motor

| Type             | B1  | B2 | H1  | H2 | L1   | L2   |
|------------------|-----|----|-----|----|------|------|
| EAMM-A-M80-68GA  | 96  | 92 | 96  | 82 | 26,5 | 24,5 |
| EAMM-A-M80-75GA  | 96  | 92 | 96  | 82 | 35   | 33   |
| EAMM-A-M80-84AA  | 96  | 92 | 96  | 82 | 27   | 25   |
| EAMM-A-M80-80G   | 96  | 92 | 96  | 82 | 19   | 15   |
| EAMM-A-M80-90GA  | 116 | 92 | 96  | 82 | 33   | 31   |
| EAMM-A-M80-115GA | 116 | 92 | 102 | 82 | 67   | 65   |
| EAMM-A-M80-120G  | 124 | –  | 124 | –  | 34   | –    |
| EAMM-A-M80-120GA | 140 | 92 | 102 | 82 | 35   | 33   |
| EAMM-A-M80-120GB | 140 | 92 | 122 | 82 | 39   | 37   |
| EAMM-A-M80-120GC | 140 | 92 | 124 | 82 | 49   | 47   |

## Ordering data – Individual components

| Axial kit                                | Consisting of:                            |  |                                       |
|--|---|--|---------------------------------------|
|  | Motor flange                              | Coupling                                       | Centring ring                         |
|  |   |  |                                       |
| Part no.<br>Type                         | Part no.<br>Type                          | Part no.<br>Type                               | Part no.<br>Type                      |
| <b>1190076</b><br><b>EAMM-A-M43-60G</b>  | <b>1597579</b><br><b>EAMF-A-43D-60G/H</b> | <b>558001</b><br><b>EAMD-32-32-11-16X20</b>    | <b>575962</b><br><b>EAML-43-4-43</b>  |
| <b>1456612</b><br><b>EAMM-A-M43-60H</b>  | <b>1597579</b><br><b>EAMF-A-43D-60G/H</b> | <b>1377840</b><br><b>EAMD-32-32-14-16X20</b>   | <b>575962</b><br><b>EAML-43-4-43</b>  |
| <b>1456614</b><br><b>EAMM-A-M48-60H</b>  | <b>1460111</b><br><b>EAMF-A-48C-60G/H</b> | <b>3420022</b><br><b>EAMD-42-40-14-16X25-U</b> | <b>558031</b><br><b>EAML-48-4-48</b>  |
| <b>1190421</b><br><b>EAMM-A-M48-80G</b>  | <b>1190375</b><br><b>EAMF-A-48C-80G</b>   | <b>1781043</b><br><b>EAMD-42-40-20-16X25-U</b> | <b>558031</b><br><b>EAML-48-4-48</b>  |
| <b>1190774</b><br><b>EAMM-A-M80-120G</b> | <b>1190702</b><br><b>EAMF-A-80A-120G</b>  | <b>1781045</b><br><b>EAMD-56-46-25-23X27-U</b> | <b>1209006</b><br><b>EAML-80-6-80</b> |

Datasheet

Dimensions (sample illustration)

Download CAD data → [www.festo.com](http://www.festo.com)

ELGC-TB-...

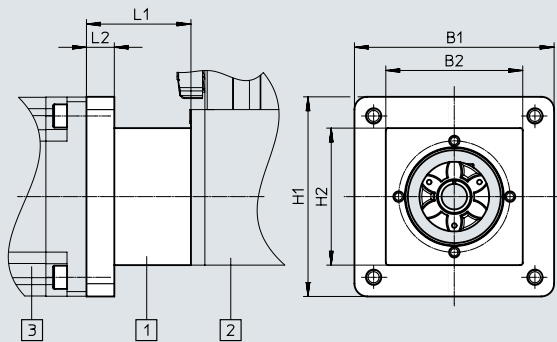

Main illustration:

- [1] Axial kit
- [2] Toothed belt axis
- [3] Motor

ELGC-BS-...

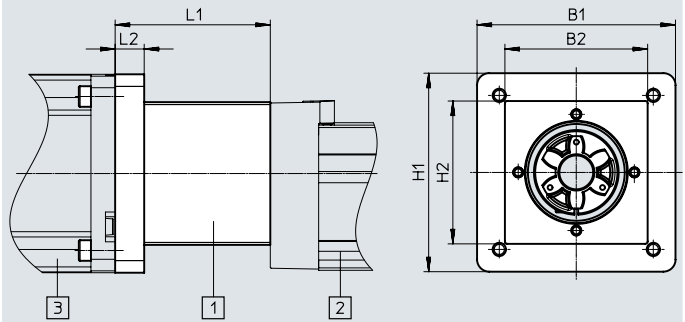

Main illustration:

- [1] Axial kit
- [2] Ball screw axis
- [3] Motor

EGSC-BS-...

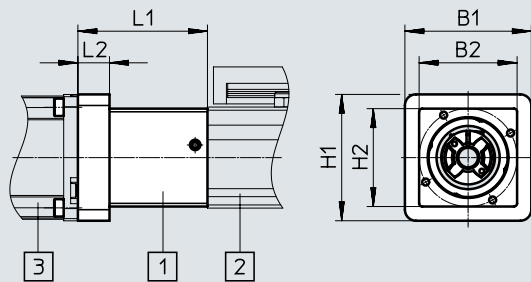

Main illustration:

- [1] Axial kit
- [2] Mini slide
- [3] Motor

EPCC

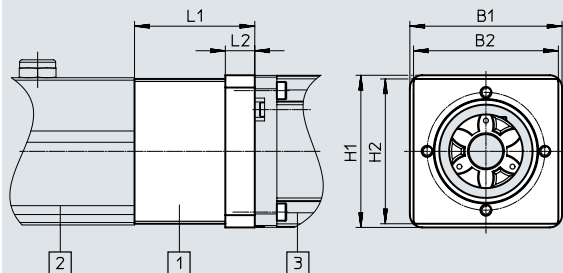

Main illustration:

- [1] Axial kit
- [2] Electric cylinder
- [3] Motor

ELGT-BS-...

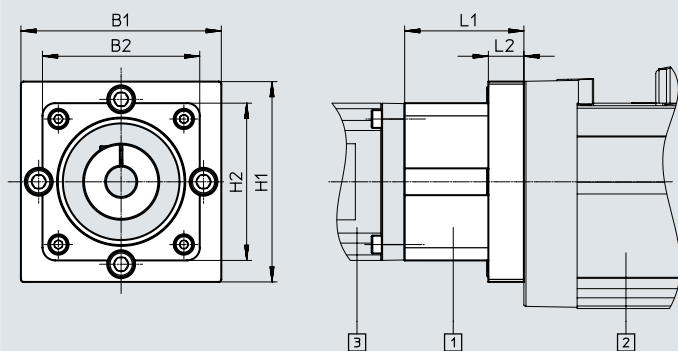

Main illustration:

- [1] Axial kit
- [2] Ball screw axis
- [3] Motor

## Datasheet

| Dimensions and ordering data |      |      |      |      |            |     |
|------------------------------|------|------|------|------|------------|-----|
| Type                         | B1   | B2   | H1   | H2   | L1<br>±0.1 | L2  |
| EAMM-A-V20-28A               | 28   | 24.5 | 28   | 24.5 | 36.4       | 4   |
| EAMM-A-V20-28AA              | 28   | 24.5 | 28   | 24.5 | 31.4       | 5.5 |
| EAMM-A-V25-35A               | 35.2 | 31   | 35.2 | 31   | 40         | 7   |
| EAMM-A-V25-38AA              | 38   | 31   | 38   | 31   | 46         | 12  |
| EAMM-A-V25-40P               | 40   | 31   | 40   | 31   | 41         | 10  |
| EAMM-A-V25-40R               | 40   | 31   | 40   | 31   | 46         | 14  |
| EAMM-A-V25-40RA              | 40   | 31   | 40   | 31   | 39         | 14  |
| EAMM-A-V25-42A               | 42   | 31   | 42   | 31   | 40         | 6   |
| EAMM-A-V25-42AB              | 42   | 31   | 42   | 31   | 36         | 6   |
| EAMM-A-V32-38AA              | 38   | 44   | 38   | 44   | 46         | 35  |
| EAMM-A-V32-40P               | 40   | 44   | 40   | 44   | 41         | 30  |
| EAMM-A-V32-40R               | 40   | 44   | 40   | 44   | 46         | 35  |
| EAMM-A-V32-40RA              | 40   | 44   | 40   | 44   | 39         | 28  |
| EAMM-A-V32-42A               | 42   | 44   | 42   | 44   | 40         | 32  |
| EAMM-A-V32-42AB              | 42   | 44   | 42   | 44   | 36         | 28  |
| EAMM-A-V32-57A               | 56.4 | 44   | 56.4 | 44   | 41.5       | 11  |
| EAMM-A-V32-58AA              | 58   | 44   | 58   | 44   | 41         | 17  |
| EAMM-A-V32-60AA              | 60   | 44   | 60   | 44   | 42         | 17  |
| EAMM-A-V32-60P               | 62   | 44   | 62   | 44   | 55.1       | 11  |
| EAMM-A-V32-60PA              | 62   | 44   | 62   | 44   | 55         | 17  |
| EAMM-A-V32-60RA              | 62   | 44   | 62   | 44   | 55         | 17  |
| EAMM-A-T42-55A               | 59   | 59   | 59   | 59   | 43         | –   |
| EAMM-A-T42-57A               | 59   | 59   | 59   | 59   | 43         | –   |
| EAMM-A-T42-58AA              | 59   | 59   | 59   | 59   | 43         | –   |
| EAMM-A-T42-60AA              | 59   | 59   | 59   | 59   | 43         | –   |
| EAMM-A-T42-60AB              | 59   | 59   | 59   | 59   | 43         | –   |
| EAMM-A-T42-60P               | 62   | 59   | 62   | 59   | 49         | 12  |
| EAMM-A-T42-60R               | 62   | 59   | 62   | 59   | 49         | 12  |
| EAMM-A-T42-60RA              | 62   | 59   | 62   | 59   | 49         | 12  |
| EAMM-A-T42-80P               | 82   | 59   | 82   | 59   | 64.1       | 12  |
| EAMM-A-T42-87A               | 86   | 59   | 86   | 59   | 45         | 12  |
| EAMM-A-T46-57A               | 79   | 56.4 | 79   | 56.4 | 42         | 14  |
| EAMM-A-T46-60P               | 62   | 79   | 62   | 79   | 47         | 33  |
| EAMM-A-T46-60R               | 62   | 79   | 62   | 79   | 47         | 33  |
| EAMM-A-T46-60RA              | 62   | 79   | 62   | 79   | 47         | 33  |
| EAMM-A-T46-70A               | 79   | 79   | 79   | 79   | 42         | –   |
| EAMM-A-T46-70AA              | 79   | 79   | 79   | 79   | 47         | –   |
| EAMM-A-T46-80P               | 79   | 79   | 79   | 79   | 63.1       | –   |
| EAMM-A-T46-80PA              | 79   | 79   | 79   | 79   | 68.5       | –   |
| EAMM-A-T46-80PB              | 79   | 79   | 79   | 79   | 68.5       | –   |
| EAMM-A-T46-85AA              | 85   | 79   | 85   | 79   | 55         | 14  |
| EAMM-A-T46-87A               | 86   | 79   | 86   | 79   | 44         | 12  |
| EAMM-A-T46-100A              | 100  | 79   | 100  | 79   | 68.1       | 22  |

Datasheet

Dimensions (sample illustration)

Download CAD data → [www.festo.com](http://www.festo.com)

EGSK...

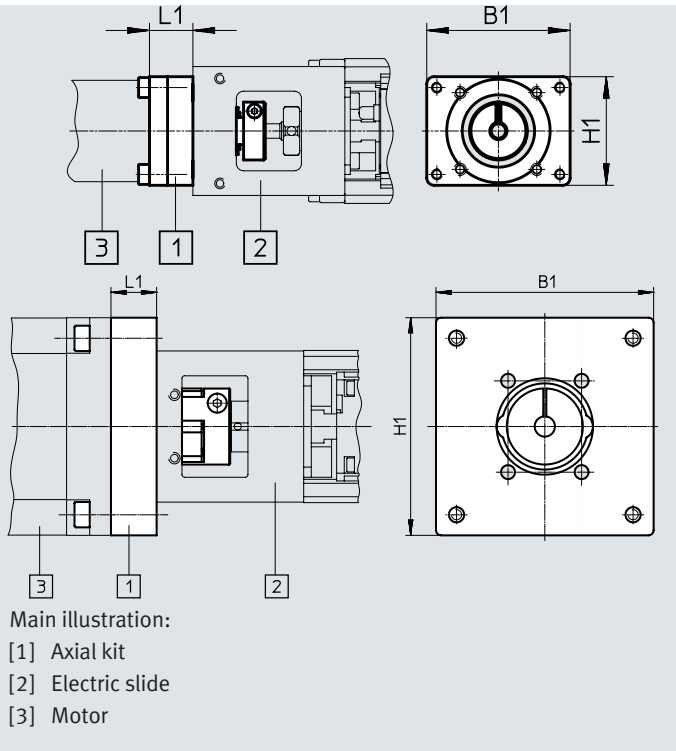

| Type               | B1   | H1   | L1    |
|--------------------|------|------|-------|
| EAMM-A-P3-28D-28A  | 30   | 30   | 15    |
| EAMM-A-P3-28D-40P  | 39.7 | 39.7 | 14.5  |
| EAMM-A-P4-28B-28A  | 39.6 | 30   | 12    |
| EAMM-A-P4-28B-38AA | 38   | 38   | 17.5  |
| EAMM-A-P4-28B-40A  | 40   | 40   | 8.3   |
| EAMM-A-P4-28B-40P  | 39.7 | 39.7 | 12.5  |
| EAMM-A-P4-28B-40R  | 40   | 40   | 17.5  |
| EAMM-A-P4-28B-40RA | 40   | 40   | 10.5  |
| EAMM-A-P4-28B-42A  | 42   | 42   | 16.5  |
| EAMM-A-P5-28B-28A  | 39.6 | 30   | 12    |
| EAMM-A-P5-28B-38AA | 38   | 38   | 17.5  |
| EAMM-A-P5-28B-40A  | 40   | 40   | 8.3   |
| EAMM-A-P5-28B-40P  | 39.7 | 39.7 | 12.5  |
| EAMM-A-P5-28B-40R  | 40   | 40   | 17.5  |
| EAMM-A-P5-28B-40RA | 40   | 40   | 10.5  |
| EAMM-A-P5-28B-42A  | 42   | 42   | 16.5  |
| EAMM-A-P6-38A-40A  | 50   | 50   | 9     |
| EAMM-A-P6-38A-40G  | 60   | 60   | 17    |
| EAMM-A-P6-38A-40P  | 50   | 50   | 10.7  |
| EAMM-A-P6-38A-42A  | 55   | 55   | 15    |
| EAMM-A-P6-38A-55A  | 55   | 55   | 11    |
| EAMM-A-P6-38A-57A  | 56   | 56   | 11    |
| EAMM-A-P6-38A-58AA | 58   | 58   | 10.6  |
| EAMM-A-P6-38A-60P  | 61.4 | 61.4 | 21    |
| EAMM-A-P6-38A-60R  | 61.4 | 61.4 | 21    |
| EAMM-A-P6-38A-60RA | 61.4 | 61.4 | 21    |
| EAMM-A-P8-38A-40A  | 50   | 50   | 9     |
| EAMM-A-P8-38A-40G  | 60   | 60   | 17    |
| EAMM-A-P8-38A-40P  | 50   | 50   | 10.7  |
| EAMM-A-P8-38A-42A  | 55   | 55   | 15    |
| EAMM-A-P8-38A-55A  | 55   | 55   | 11    |
| EAMM-A-P8-38A-57A  | 56   | 56   | 11    |
| EAMM-A-P8-38A-58AA | 58   | 58   | 10.6  |
| EAMM-A-P8-38A-60AA | 60   | 60   | 11.5  |
| EAMM-A-P8-38A-60P  | 61.4 | 61.4 | 21    |
| EAMM-A-P8-38A-60R  | 62   | 62   | 11.8  |
| EAMM-A-P8-38A-60RA | 62   | 62   | 11.8  |
| EAMM-A-P8-38A-70A  | 70   | 70   | 13.8  |
| EAMM-A-P8-38A-70AA | 70   | 70   | 13.75 |
| EAMM-A-P8-38A-87A  | 85.8 | 85.8 | 18    |
| EAMM-A-P10-38A-40G | 60   | 60   | 17    |
| EAMM-A-P10-38A-55A | 55   | 55   | 11    |
| EAMM-A-P10-38A-57A | 56   | 56   | 11    |
| EAMM-A-P10-38A-60P | 61.4 | 61.4 | 21    |
| EAMM-A-P10-38A-70A | 70   | 70   | 13.8  |
| EAMM-A-P10-38A-87A | 85.8 | 85.8 | 18    |

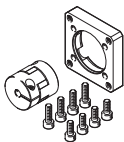
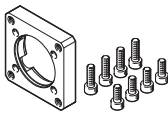
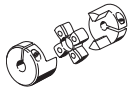

## Datasheet

| Ordering data – Individual components   |   |   |
|---|---|---|
| Axial kit   | Consisting of:  |   |
|   | Motor flange  | Coupling  |
|  |  |  |
| Part no.<br>Type  | Part no.<br>Type  | Part no.<br>Type  |
| 1703478<br>EAMM-A-P3-28D-28A  | 1087613<br>EAMF-A-28D-28A   | 562672<br>EAMC-16-20-3-5  |
| 1982886<br>EAMM-A-P3-28D-40P  | 1982014<br>EAMF-A-28D-40P   | 2310368<br>EAMC-16-20-3-8   |
| 1731466<br>EAMM-A-P4-28B-28A  | 1704476<br>EAMF-A-28B-28A   | 562674<br>EAMC-16-20-4-5  |
| 1983071<br>EAMM-A-P4-28B-40P  | 1976704<br>EAMF-A-28B-40P   | 562675<br>EAMC-16-20-4-8  |
| 562637<br>EAMM-A-P4-28B-40A   | 552163<br>EAMF-A-28B-40A  | 562673<br>EAMC-16-20-4-6  |
| 562636<br>EAMM-A-P4-28B-42A   | 552164<br>EAMF-A-28B-42A  | 562674<br>EAMC-16-20-4-5  |
| 1731474<br>EAMM-A-P5-28B-28A  | 1704476<br>EAMF-A-28B-28A   | 562676<br>EAMC-16-20-5-5  |
| 562641<br>EAMM-A-P5-28B-40A   | 552163<br>EAMF-A-28B-40A  | 543419<br>EAMC-16-20-5-6  |
| 1983122<br>EAMM-A-P5-28B-40P  | 1976704<br>EAMF-A-28B-40P   | 562677<br>EAMC-16-20-5-8  |
| 562640<br>EAMM-A-P5-28B-42A   | 552164<br>EAMF-A-28B-42A  | 562676<br>EAMC-16-20-5-5  |
| 562646<br>EAMM-A-P6-38A-40A   | 562667<br>EAMF-A-38A-40A  | 558312<br>EAMC-30-32-6-6  |
| 2297645<br>EAMM-A-P6-38A-40G  | 1460097<br>EAMF-A-38A-40G   | 562681<br>EAMC-30-32-6-10   |
| 1983450<br>EAMM-A-P6-38A-40P  | 1984478<br>EAMF-A-38A-40P   | 533708<br>EAMC-30-32-6-8  |
| 562644<br>EAMM-A-P6-38A-42A   | 562668<br>EAMF-A-38A-42A  | 561333<br>EAMC-30-32-5-6  |
| 562647<br>EAMM-A-P6-38A-55A   | 558176<br>EAMF-A-38A-55A  | 551003<br>EAMC-30-32-6-9  |
| 562645<br>EAMM-A-P6-38A-57A   | 560692<br>EAMF-A-38A-57A  | 551002<br>EAMC-30-32-6-6.35   |
| 2264375<br>EAMM-A-P6-38A-60P  | 1987412<br>EAMF-A-38A-60P   | 1233256<br>EAMC-30-32-6-14  |

## Datasheet

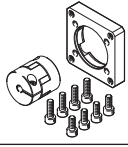
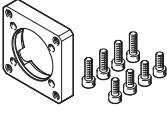
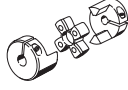
| Ordering data – Individual components   |   |   |
|---|---|---|
| Axial kit   | Consisting of:  |   |
|   | Motor flange  | Coupling  |
|  |  |  |
| Part no.<br>Type  | Part no.<br>Type  | Part no.<br>Type  |
| 562652<br>EAMM-A-P8-38A-40A   | 562667<br>EAMF-A-38A-40A  | 533708<br>EAMC-30-32-6-8  |
| 2297646<br>EAMM-A-P8-38A-40G  | 1460097<br>EAMF-A-38A-40G   | 558029<br>EAMC-30-32-8-10   |
| 1986292<br>EAMM-A-P8-38A-40P  | 1984478<br>EAMF-A-38A-40P   | 543422<br>EAMC-30-32-8-8  |
| 562650<br>EAMM-A-P8-38A-42A   | 562668<br>EAMF-A-38A-42A  | 562678<br>EAMC-30-32-5-8  |
| 562653<br>EAMM-A-P8-38A-55A   | 558176<br>EAMF-A-38A-55A  | 543423<br>EAMC-30-32-8-9  |
| 562651<br>EAMM-A-P8-38A-57A   | 560692<br>EAMF-A-38A-57A  | 543421<br>EAMC-30-32-6.35-8   |
| 1987308<br>EAMM-A-P8-38A-60P  | 1987412<br>EAMF-A-38A-60P   | 562682<br>EAMC-30-32-8-14   |
| 564996<br>EAMM-A-P8-38A-70A   | 558018<br>EAMF-A-38A-70A  | 551004<br>EAMC-30-32-8-11   |
| 564998<br>EAMM-A-P8-38A-87A   | 560693<br>EAMF-A-38A-87A  | 551004<br>EAMC-30-32-8-11   |
| 2297648<br>EAMM-A-P10-38A-40G   | 1460097<br>EAMF-A-38A-40G   | 2310372<br>EAMC-30-32-10-10   |
| 562659<br>EAMM-A-P10-38A-55A  | 558176<br>EAMF-A-38A-55A  | 562680<br>EAMC-30-32-9-10   |
| 562658<br>EAMM-A-P10-38A-57A  | 560692<br>EAMF-A-38A-57A  | 562679<br>EAMC-30-32-6.35-10  |
| 2036017<br>EAMM-A-P10-38A-60P   | 1987412<br>EAMF-A-38A-60P   | 562683<br>EAMC-30-32-10-14  |
| 564997<br>EAMM-A-P10-38A-70A  | 558018<br>EAMF-A-38A-70A  | 565008<br>EAMC-30-32-10-11  |
| 564999<br>EAMM-A-P10-38A-87A  | 560693<br>EAMF-A-38A-87A  | 565008<br>EAMC-30-32-10-11  |

## Datasheet

## Dimensions (sample illustration)

Download CAD data → [www.festo.com](http://www.festo.com)

ELGG-..., ELGR-...

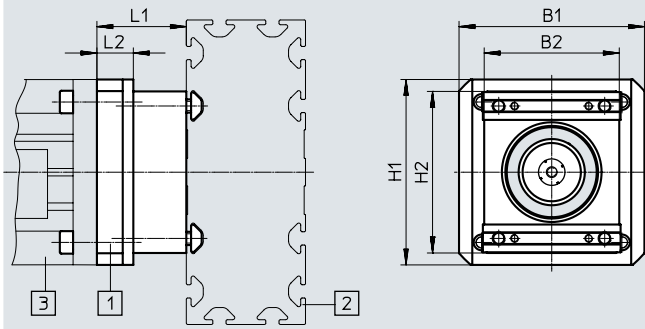



Main illustration:

- [1] Axial kit
- [2] Toothed belt axis
- [3] Motor

| Type            | B1    | B2   | H1    | H2   | L1   | L2   |
|-----------------|-------|------|-------|------|------|------|
| EAMM-A-R27-40G  | 60    | 44.5 | 60    | 48.3 | 32   | 17   |
| EAMM-A-R27-55A  | 55    | 44.5 | 55    | 48.3 | 26   | 11   |
| EAMM-A-R27-57A  | 56    | 44.5 | 56    | 48.3 | 26   | 11   |
| EAMM-A-R38-40G  | 60    | 51   | 60    | 61   | 37   | 17   |
| EAMM-A-R38-57A  | 56    | –    | –     | –    | 31   | –    |
| EAMM-A-R38-60G  | 60    | 51   | 60    | 61   | 46   | 26   |
| EAMM-A-R38-60H  | 60    | 51   | 60    | 61   | 46   | 26   |
| EAMM-A-R38-60P  | 61.4  | 51   | 61.4  | 61   | 41   | 21   |
| EAMM-A-R38-70A  | 70    | 51   | 70    | 61   | 33.8 | 13.8 |
| EAMM-A-R38-87A  | 85.8  | 51   | 85.8  | 61   | 38   | 18   |
| EAMM-A-R48-60G  | 60    | 55   | 60    | 81   | 52.5 | 24.5 |
| EAMM-A-R48-60H  | 60    | 55   | 60    | 51   | 52.5 | 24.5 |
| EAMM-A-R48-70A  | 70    | –    | –     | –    | 40.2 | –    |
| EAMM-A-R48-80P  | 81.3  | 55   | 81.3  | 81   | 54   | 26   |
| EAMM-A-R48-87A  | 85.8  | 55   | 85.8  | 81   | 44   | 16   |
| EAMM-A-R48-100A | 100.5 | 55   | 100.5 | 81   | 59   | 31   |

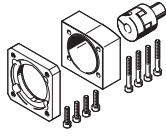
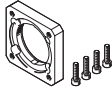
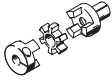
## Datasheet

| Ordering data – Individual components   |   |  |   |
|---|---|--|---|
| Axial kit   | Consisting of:  |  |   |
|   | Motor flange  | Coupling   | Coupling housing  |
|  |  |  |  |
| Part no.<br>Type  | Part no.<br>Type  | Part no.<br>Type   | Part no.<br>Type  |
| 1456622<br>EAMM-A-R27-40G   | 14600097<br>EAMF-A-38A-40G  | 557998<br>EAMD-19-15-10-8X10   | 1133397<br>EAMK-A-R27-38A   |
| 1133400<br>EAMM-A-R27-55A   | 558176<br>EAMF-A-38A-55A  | 557999<br>EAMD-19-15-9-8X10  | 1133397<br>EAMK-A-R27-38A   |
| 1133403<br>EAMM-A-R27-57A   | 560692<br>EAMF-A-38A-57A  | 561292<br>EAMD-16-15-6.35-8X10   | 1133397<br>EAMK-A-R27-38A   |
| 1456623<br>EAMM-A-R38-40G   | 1460097<br>EAMF-A-38A-40G   | 1453860<br>EAMD-25-22-10-10X12   | 1133398<br>EAMK-A-R38-38A   |
| 1578138<br>EAMM-A-R38-57A   | 560692<br>EAMF-A-38A-57A  | 561293<br>EAMD-25-22-6.35-10X12  | 1133398<br>EAMK-A-R38-38A   |
| 2310075<br>EAMM-A-R38-60G   | 558017<br>EAMF-A-38A-60G/H  | 558000<br>EAMD-25-22-11-10X12  | 1133398<br>EAMK-A-R38-38A   |
| 1456630<br>EAMM-A-R38-60H   | 558017<br>EAMF-A-38A-60G/H  | 1453861<br>EAMD-28-22-14-10X12   | 1133398<br>EAMK-A-R38-38A   |
| 2224996<br>EAMM-A-R38-60P   | 1987412<br>EAMF-A-38A-60P   | 1453861<br>EAMD-28-22-14-10X12   | 1133398<br>EAMK-A-R38-38A   |
| 1133401<br>EAMM-A-R38-70A   | 558018<br>EAMF-A-38A-70A  | 558000<br>EAMD-25-22-11-10X12  | 1133398<br>EAMK-A-R38-38A   |
| 1133404<br>EAMM-A-R38-87A   | 560693<br>EAMF-A-38A-87A  | 558000<br>EAMD-25-22-11-10X12  | 1133398<br>EAMK-A-R38-38A   |
| 2374780<br>EAMM-A-R48-60G   | 558019<br>EAMF-A-48A-60G/H  | 558001<br>EAMD-32-32-11-16X20  | 1133399<br>EAMK-A-R48-48A   |
| 1456633<br>EAMM-A-R48-60H   | 558019<br>EAMF-A-48A-60G/H  | 1377840<br>EAMD-32-32-14-16X20   | 1133399<br>EAMK-A-R48-48A   |
| 1578139<br>EAMM-A-R48-70A   | 558025<br>EAMF-A-48A-70A  | 558001<br>EAMD-32-32-11-16X20  | 1133399<br>EAMK-A-R48-48A   |
| 2225090<br>EAMM-A-R48-80P   | 2043427<br>EAMF-A-48A-80P   | 558002<br>EAMD-42-40-19-16X25  | 1133399<br>EAMK-A-R48-48A   |
| 1133405<br>EAMM-A-R48-87A   | 560695<br>EAMF-A-48A-87A  | 558001<br>EAMD-32-32-11-16X20  | 1133399<br>EAMK-A-R48-48A   |
| 1133402<br>EAMM-A-R48-100A  | 558020<br>EAMF-A-48A-100A   | 558002<br>EAMD-42-40-19-16X25  | 1133399<br>EAMK-A-R48-48A   |

# Datasheet

## Dimensions (sample illustration)

Download CAD data → [www.festo.com](http://www.festo.com)

EXCM-...,

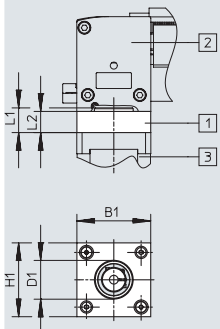

Main illustration:  
 [1] Axial kit  
 [2] Planar surface gantry  
 [3] Motor

| Type           | Type    | B1<br>±0.1 | D1<br>h8 | H1<br>±0.1 | L1 | L2<br>±0.1 |
|----------------|---------|------------|----------|------------|----|------------|
| EAMM-A-X22-42A | EXCM-30 | 41.9       | 22       | 41.9       | 14 | 12         |

EXCM-..., EXCH-...

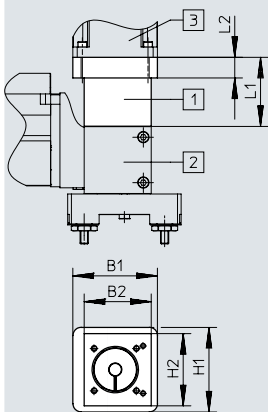

Main illustration:  
 [1] Axial kit  
 [2] Planar surface gantry  
 [3] Motor

| Type            | Type    | B1  | B2   | H1  | H2   | L1   | L2 |
|-----------------|---------|-----|------|-----|------|------|----|
| EAMM-A-X48-57A  | EXCM-40 | 70  | 70   | 70  | 70   | 53.6 | –  |
| EAMM-A-X48-87A  | EXCM-40 | 86  | 69.5 | 86  | 69.5 | 60   | 20 |
| EAMM-A-X48-80P  | EXCH-40 | 82  | 70   | 82  | 65   | 67   | 20 |
| EAMM-A-X62-100A | EXCH-60 | 104 | 100  | 104 | 90.5 | 62   | 22 |
| EAMM-A-X62-150A | EXCH-60 | 151 | 100  | 151 | 90.5 | 71.5 | 29 |

EXCT-...,

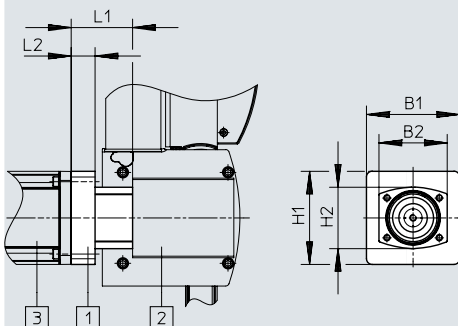

Main illustration:  
 [1] Axial kit  
 [2] Linear gantry  
 [3] Motor

| Type            | Type    | B1  | B2 | H1  | H2 | L1   | L2 |
|-----------------|---------|-----|----|-----|----|------|----|
| EAMM-A-Y62-100A | EXCT-30 | 104 | 92 | 104 | 79 | 62.5 | 24 |

## Accessories

### Seal set

Contains paint-wetting impairment substances  
RoHS-compliant

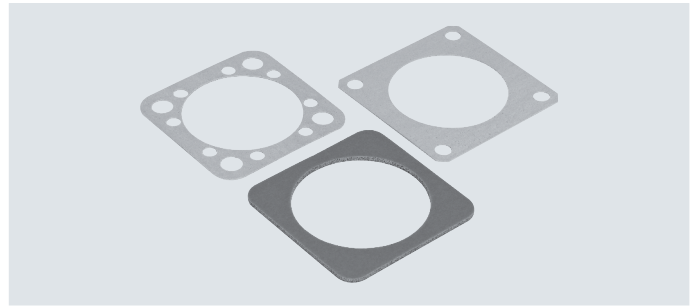

| Ordering data       |  |                        |                          |                   |          |                     |
|---------------------|--|------------------------|--------------------------|-------------------|----------|---------------------|
| Type                | For axial kit                          | For electric cylinder  | Ambient temperature [°C] | CRC <sup>1)</sup> | Part no. | Type                |
| EADS-F-D32-40A      | EAMM-A-D32-40A                         | ESBF, EGSL, ERMB, ERMH | -25 ... +60              | 4                 | 1561526  | EADS-F-D32-40A      |
| EADS-F-D32-40G      | EAMM-A-D32-40G                         |                        |                          |                   | 2253500  | EADS-F-D32-40G      |
| EADS-F-D32-40P      | EAMM-A-D32-40P                         |                        |                          |                   | 2207219  | EADS-F-D32-40P      |
| EADS-F-D32-60G/H    | EAMM-A-D32-60G<br>EAMM-A-D32-60H       |                        |                          |                   | 8022150  | EADS-F-D32-60G/H    |
| EADS-F-D32-60P-G2   | EAMM-A-D32-60P-G2                      |                        |                          |                   | 8197395  | EADS-F-D32-60P-G2   |
| EADS-F-D32-42A      | EAMM-A-D32-42A                         |                        |                          |                   | 1561527  | EADS-F-D32-42A      |
| EADS-F-D32-55A      | EAMM-A-D32-55A                         |                        |                          |                   | 1561528  | EADS-F-D32-55A      |
| EADS-F-D32-57A      | EAMM-A-D32-57A                         |                        |                          |                   | 1561529  | EADS-F-D32-57A      |
| EADS-F-D40-55A      | EAMM-A-D40-55A                         |                        |                          |                   | 1561530  | EADS-F-D40-55A      |
| EADS-F-D40-57A      | EAMM-A-D40-57A                         |                        |                          |                   | 1561531  | EADS-F-D40-57A      |
| EADS-F-D40-60G/H    | EAMM-A-D40-60G<br>EAMM-A-D40-60H       |                        |                          |                   | 2253503  | EADS-F-D40-60G/H    |
| EADS-F-D40-60P-G2   | EAMM-A-D40-60P-G2                      |                        |                          |                   | 8197397  | EADS-F-D40-60P-G2   |
| EADS-F-D40-70A      | EAMM-A-D40-70A                         |                        |                          |                   | 1561532  | EADS-F-D40-70A      |
| EADS-F-D40-87A      | EAMM-A-D40-87A                         |                        |                          |                   | 1561533  | EADS-F-D40-87A      |
| EADS-F-D50-60G/H-G2 | EAMM-A-D50-60G-G2<br>EAMM-A-D50-60H-G2 |                        |                          |                   | 8197506  | EADS-F-D50-60G/H-G2 |
| EADS-F-D50-70A      | EAMM-A-D50-70A                         |                        |                          |                   | 2733789  | EADS-F-D50-70A      |
| EADS-F-D50-80G      | EAMM-A-D50-80G                         |                        |                          |                   | 2733793  | EADS-F-D50-80G      |
| EADS-F-D50-80P-G2   | EAMM-A-D50-80P-G2                      |                        |                          |                   | 8197394  | EADS-F-D50-80P-G2   |
| EADS-F-D50-87A      | EAMM-A-D50-87A                         |                        |                          |                   | 2733788  | EADS-F-D50-87A      |
| EADS-F-D50-100A     | EAMM-A-D50-100A                        |                        |                          |                   | 2733790  | EADS-F-D50-100A     |
| EADS-F-D60-70A      | EAMM-A-D60-70A                         |                        |                          |                   | 8022145  | EADS-F-D60-70A      |
| EADS-F-D60-80G-G2   | EAMM-A-D60-80G-G2                      |                        |                          |                   | 8199482  | EADS-F-D60-80G-G2   |
| EADS-F-D60-60G/H    | EAMM-A-D60-60H                         |                        |                          |                   | 2253505  | EADS-F-D60-60G/H    |
| EADS-F-D60-80P      | EAMM-A-D60-80P                         |                        |                          |                   | 2218523  | EADS-F-D60-80P      |
| EADS-F-D60-87A      | EAMM-A-D60-87A                         |                        |                          |                   | 1561536  | EADS-F-D60-87A      |
| EADS-F-D60-100A-G2  | EAMM-A-D60-100A-G2                     |                        |                          |                   | 8197396  | EADS-F-D60-100A-G2  |
| EADS-F-D80-80G      | EAMM-A-D80-80G                         |                        |                          |                   | 8022147  | EADS-F-D80-80G      |
| EADS-F-D80-100A     | EAMM-A-D80-100A                        |                        |                          |                   | 1593617  | EADS-F-D80-100A     |
| EADS-F-D80-150A     | EAMM-A-D80-150A                        |                        |                          |                   | 8162067  | EADS-F-D80-150A     |
| EADS-F-D100-100A    | EAMM-A-D100-100A                       |                        |                          |                   | 3356966  | EADS-F-D100-100A    |
| EADS-F-D100-120G    | EAMM-A-D100-120G                       | 8022148                | EADS-F-D100-120G         |                   |          |                     |
| EADS-F-D100-150A    | EAMM-A-D100-150A                       | 8162068                | EADS-F-D100-150A         |                   |          |                     |

1) Corrosion resistance class CRC 4 to Festo standard FN 940070

Particularly high corrosion stress. Outdoor exposure under extreme corrosive conditions. Parts exposed to aggressive media, e.g. in the chemical or food industries. Such applications may need to be safeguarded with special tests (→ also FN 940082) using appropriate media.