

Linear modules HMP



# - 1 - Type discontinued Available up until 2017

FESTO

## Linear modules HMP

Key features

### At a glance

 New

- Sturdier
- Optimised end stop system
- Optimised intermediate position module
- Minimised susceptibility to wear
- One-way flow control valves that can be externally adjusted
- Integrated sensor strip

- Diameters of 16 ... 32 mm
- Stroke lengths of 50 ... 400 mm
- Extremely rigid basic profile
- Infinitely adjustable end stops
- Rotatable yoke plate
- Integrated clamping unit
- Precision backlash-free guide system
- Freely adjustable intermediate position
- Adjustable end-position cushioning
- Integrated sensors:
  - Sensor strip for proximity sensors for end-position sensing
  - Mounting slot for proximity sensors for position sensing
- Functional end cap:
  - Pneumatic interface
  - Electrical interface
- Highly flexible thanks to various mounting and assembly options:
  - Basic profile
  - Yoke plate
- Large selection of adapters for:
  - Drives
  - Grippers
- Innovative and user-friendly installation system

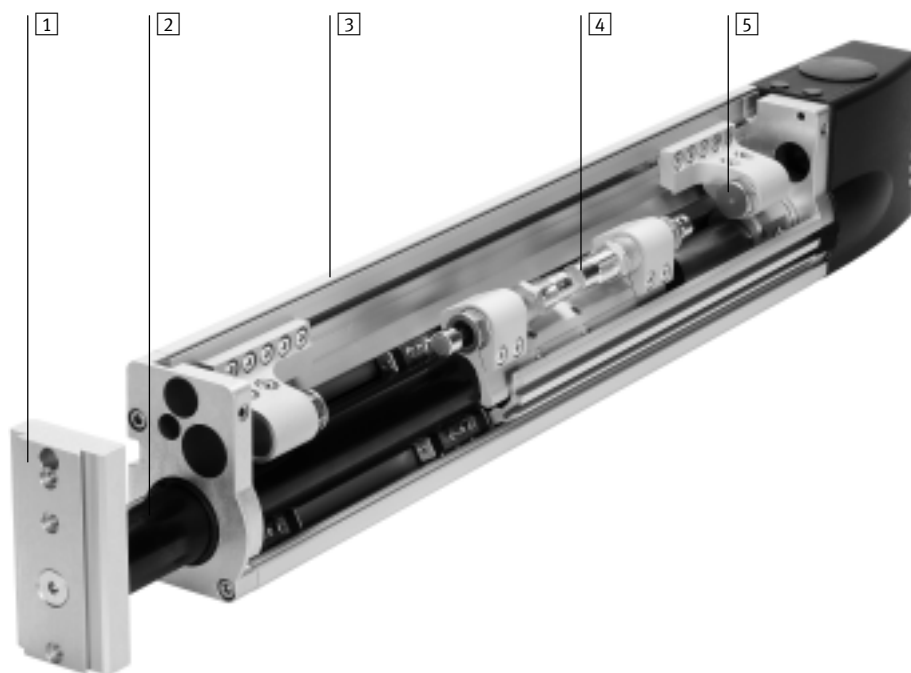

- 1** Yoke plate  
Can be turned to any angle from 0 to 360°. The yoke plate cannot be turned if combined with the clamping unit. Drives and grippers can be mounted on the yoke plate by means of adapter kits (direct mounting or dovetail connections).
- 2** Guide system  
Extremely high rigidity thanks to the hardened steel guide barrel which is supported in pre-loaded and backlash-free recirculating ball bearing guides guaranteeing the utmost precision.
- 3** Basic profile  
Drives and basic components can be attached to the rigid light alloy profile using adapter, connector and component kits.
- 4** End-position cushioning.  
Extremely dynamic operation thanks to hydraulic shock absorbers which cushion the piston sleeve at the end positions.
- 5** End stop  
Any desired intermediate position can be set between minimum and maximum stroke (plus the strokes of the shock absorbers).

## Linear modules HMP

Key features

### Wide choice of variants

#### End stop

The optimised end stop system is practically wear-free. Rough adjustment is performed by moving the stop into the profile groove. Fine adjustment is performed using compressed air via a rotatable sleeve.



#### Clamping unit

The pneumatically-powered clamping unit can be used to hold loads at any end position and with the module installed at any angle. In the case of a pressure drop or pressure failure, the clamping unit acts like an EMERGENCY STOP device. The clamping unit can be released by means of the manual override.



#### End cap

Connections can be made on the top and bottom of the end cap. Pneumatic tubing and electrical cables can be bundled and routed through the end cap via conduits.

Max. 6 proximity sensors can be connected to the integral terminal strip. The switching states of the proximity sensors are indicated via a display window in the end cap.

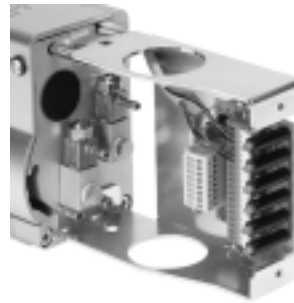

#### Intermediate position module

The intermediate position module permits advancing to an additional position between the two end positions. This is done by swivelling a lever into the traversing range of the moving stop on the guide tube.

The intermediate position can be activated during the advancing stroke or retracting stroke, depending on the type of design. Multiple intermediate position modules can be installed on request.

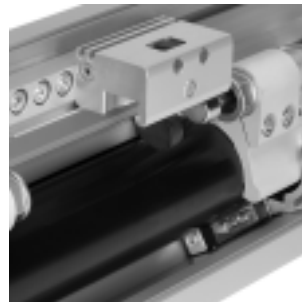



- 1 - Type discontinued  
Available up until 2017

## Linear modules HMP

Key features

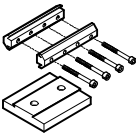
FESTO

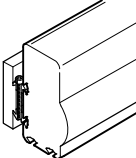
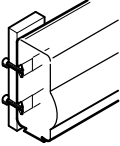
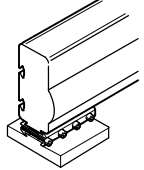
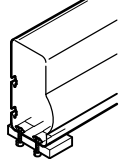
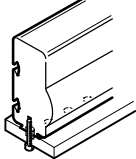
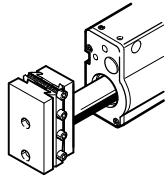
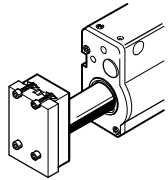
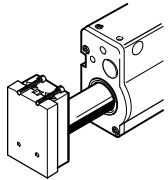
Mounting and assembly options			
Mounting options			
	Dovetail mounting using connecting kit HAVB  	Direct mounting using screws and slot nuts NST  	Direct mounting using screws and centring sleeves ZBH  
Mounting surfaces			
On the side of the basic profile	HMP-16/-20/-25/-32  	HMP-16/-20/-25/-32  	
On the underside of the basic profile	HMP-16/-20/-25/-32  	HMP-25/-32  	HMP-16/-20  
On the yoke plate	HMP-16/-20/-25/-32  	HMP-25/-32  	HMP-16/-20/-25/-32  

## Linear modules HMP

System example

System product for handling and assembly technology

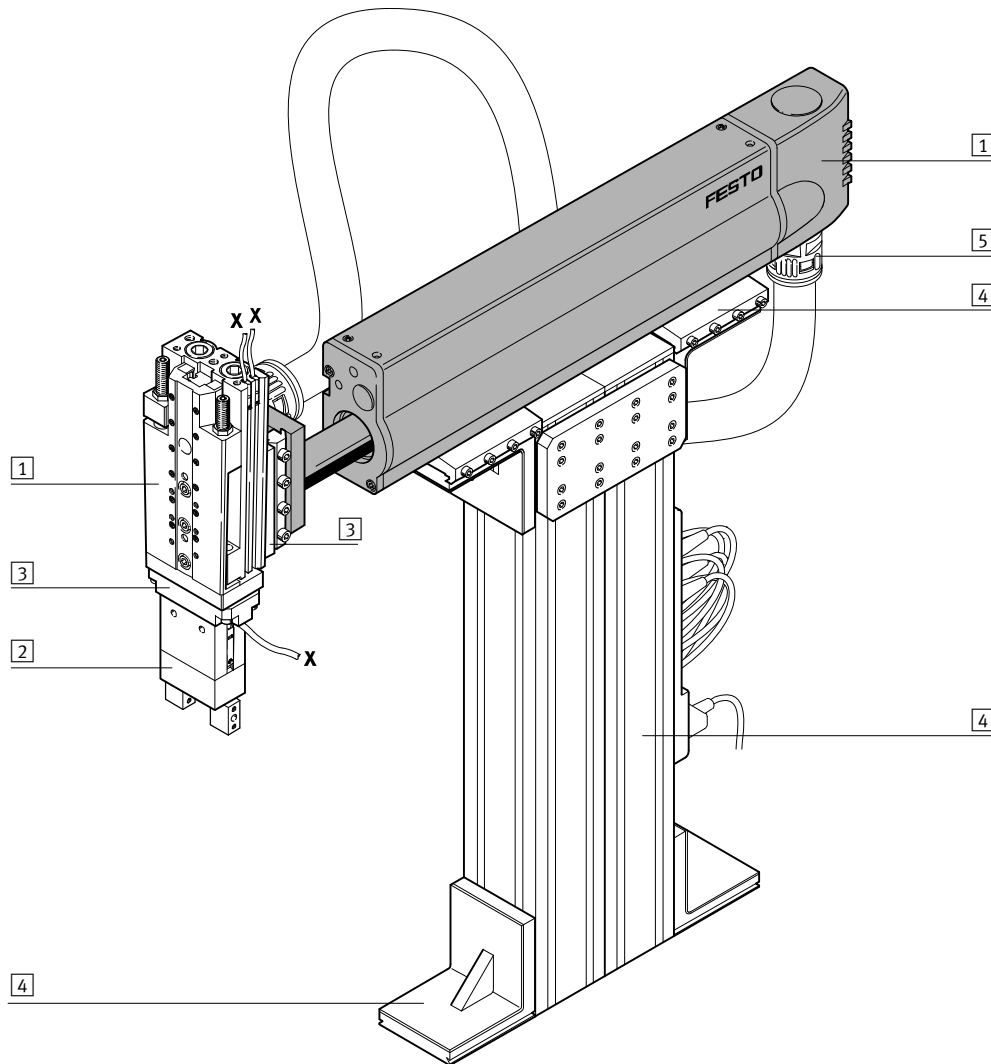

System elements and accessories		
	Description	→ Page/Internet
1	Drives	Wide range of combination options within handling and assembly technology drive
2	Grippers	Wide range of optional variants within handling and assembly technology gripper
3	Adapters	For drive/drive combinations 29 For drive/gripper combinations gripper
4	Basic components	Profiles and profile combinations as well as profile/drive combinations basic component
5	Installation components	For achieving a clear-cut, safe layout of electrical cables and tubing installation component
-	Axes	Wide range of combination options within handling and assembly technology axes
-	Motors	Servo and stepper motors, with or without gearing motor

- 7 - Type discontinued  
Available up until 2017

## Linear modules HMP

Peripherals overview

FESTO

With clamping unit KP

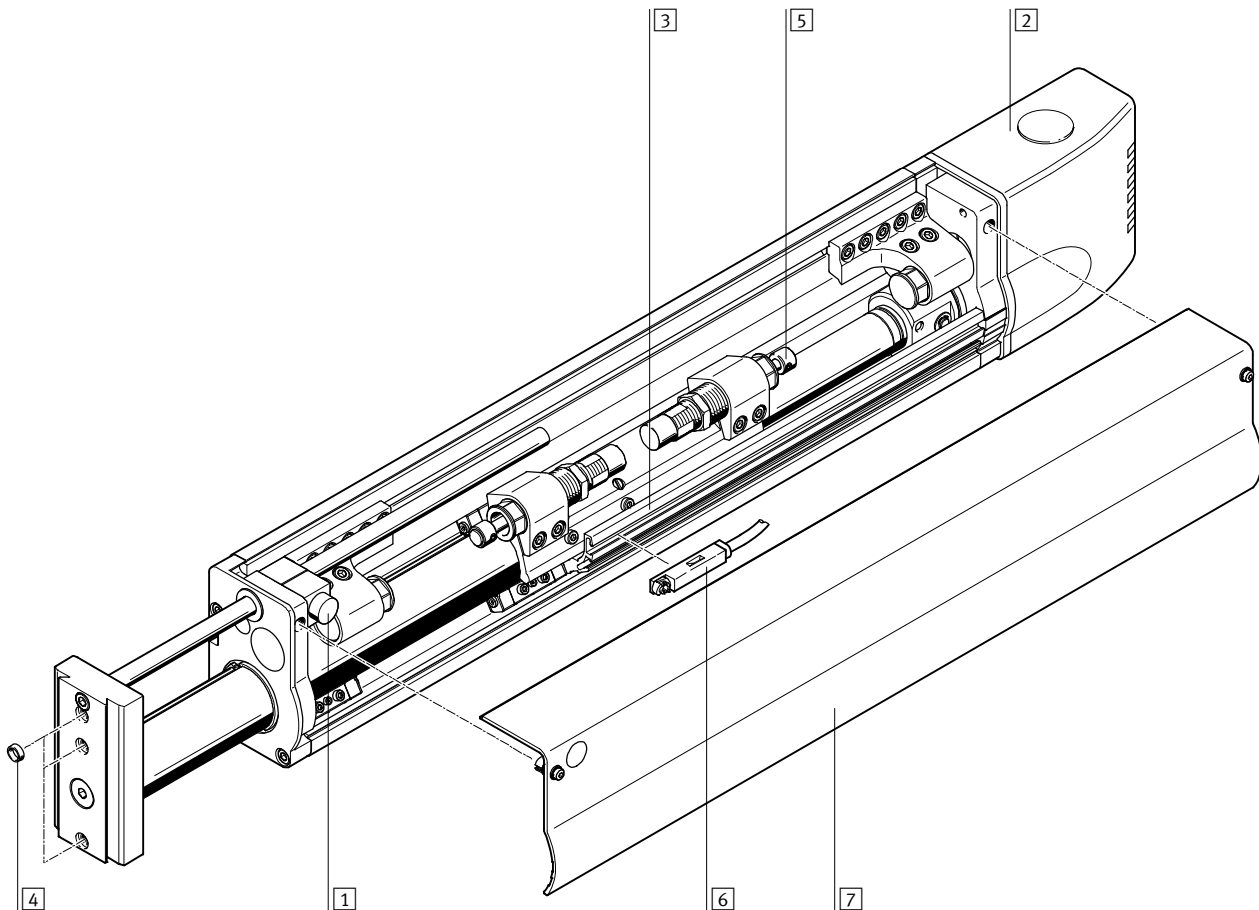

Accessories			
	Brief description	→ Page/Internet	
1	Clamping unit KP	For holding loads in all mounting and end positions in the event of a drop in pressure	24
2	End cap AD/EL	The end cap (EL) houses an integrated electrical interface	24
3	Sensor strip SL	For mounting proximity sensors and flexible sensing of any desired end positions. Included in the scope of delivery of the linear module.	24
4	Centring sleeve Z	For centring loads and attachments on the yoke plate	26
5	Shock absorber	Included in the scope of delivery of the linear module	26
6	Proximity sensor A...	For position sensing via the sensor strip	27
7	Housing cover	Included in the scope of delivery of the linear module	-
-	Cable with socket V	For proximity sensor	27
-	Slot cover A	For protecting the proximity sensor cable	26

- Z - Type discontinued  
Available up until 2017

FESTO

## Linear modules HMP

Peripherals overview

With intermediate position module Z1A

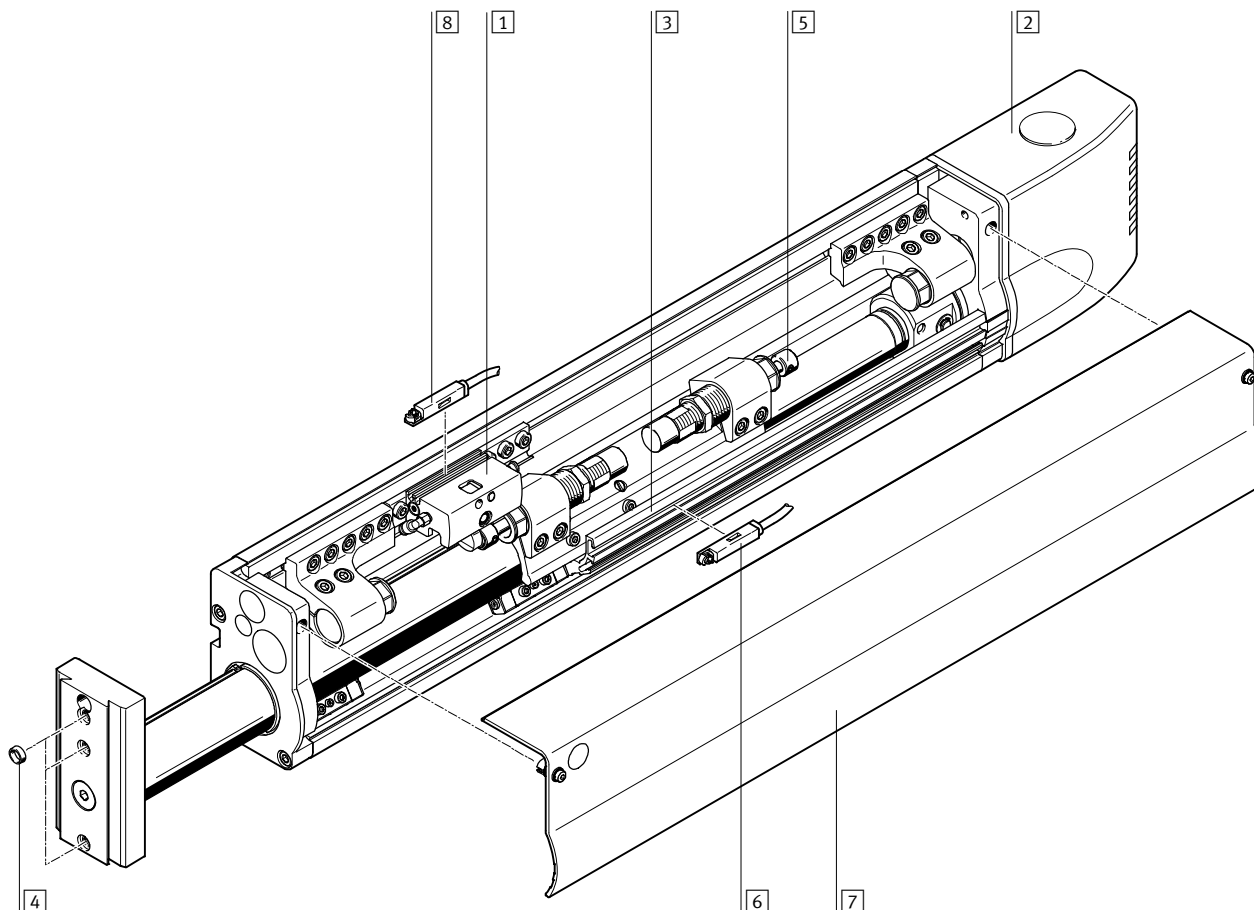

Accessories			
	Description	→ Page/Internet	
1	Intermediate position module Z1A	For approaching an intermediate position during the advance stroke. The intermediate position module Z1E is used to approach an intermediate position during the return stroke.	18
2	End cap AD/EL	The end cap (EL) houses an integrated electrical interface	24
3	Sensor strip SL	For mounting proximity sensors and flexible sensing of any desired end positions. Included in the scope of delivery of the linear module.	24
4	Centring sleeve Z	For centring loads and attachments on the yoke plate	26
5	Shock absorber	Included in the scope of delivery of the linear module	26
6	Proximity sensor A...	For position sensing via the sensor strip	27
7	Housing cover	Included in the scope of delivery of the linear module	-
8	Proximity sensor A...	For sensing the position of the lever at the intermediate position module (intermediate position active/not active)	28
-	Cable with socket V	For proximity sensor	27
-	Slot cover A	For protecting the proximity sensor cable	26

- 1 - Type discontinued  
Available up until 2017

FESTO

## Linear modules HMP

Type codes

HMP - 16 - 150 - B - SL - 2G3 - KP - - EL - A1 - E

### Type

HMP	Linear module
-----	---------------

### Piston Ø [mm]

### Stroke [mm]

### Generation

B	B series
---	----------

### Sensing

SL	Sensor strip
----	--------------

### Pneumatic connection

2G3	For 3 mm I.D. tubing
2G4	For 4 mm I.D. tubing
2G6	For 6 mm I.D. tubing

### Clamping unit

KP	Attached
----	----------

### Intermediate position module

Z1A	For advance stroke
Z1E	For return stroke

### Interface

AD	End cap
EL	End cap with electrical interface

### Proximity sensor

A1	With cable, 2.5 m
A2	Contactless with cable, 2.5 m, NPN
A3	Contactless with cable, 2.5 m, PNP
A4	With plug
A5	Contactless with plug, NPN
A6	Contactless with plug, PNP

### User documentation

E	English
S	Spanish
F	French
I	Italian
V	Swedish
B	Express waiver – no manual to be included (already available)



- 2 - Type discontinued  
Available up until 2017

FESTO

## Linear modules HMP

Type codes



		+ ZUB	-	A	Z
<b>Accessories</b>					
ZUB	Accessories supplied loose				
<b>Cable with socket</b>					
...V	2.5 m				
<b>Slot cover</b>					
A	Slot cover				
<b>Centring sleeve</b>					
...Z	For yoke plate				

- 1 - Type discontinued  
Available up until 2017

## Linear modules HMP

Technical data

FESTO

Function

Standard version

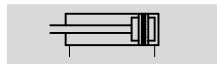

with clamping unit

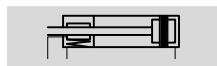

- Ø - Piston Ø  
16 ... 32 mm

- | - Stroke length  
50 ... 400 mm

- T - [www.festo.com](http://www.festo.com)



General technical data				
Piston Ø	16	20	25	32
System mode	Yoke			
Mode of operation	Double-acting			
Protection against torsion	Guide			
Connection type	Female thread			
Pneumatic connection, linear module	M5	G1/8	G1/8	G1/4
Pneumatic connection, intermediate position module	M3			
Assembly position	Any			
Effective stroke [mm]	16 ... 320	24 ... 400	24 ... 400	40 ... 400
Position sensing	For proximity sensing			
Max. repetition accuracy <sup>1)</sup> [mm]	0.01			
Max. speed	advancing [m/s]	0.8	1.1	1.1
	returning [m/s]	0.8	1.1	1.1
Swivel time of lever at intermediate position module	advancing [s]	0.04	0.04	0.04
	returning [s]	0.04	0.036	0.034

1) Variation of end position and intermediate position for 100 successive strokes under constant operating conditions

Operating and environmental conditions				
Piston Ø	16	20	25	32
Operating pressure [bar]	4 ... 8			
Operating medium	Compressed air in accordance with ISO 8573-1:2010 [7:4:4]			
Note on operating/pilot medium	Operation with lubricated medium possible (in which case lubricated operation will always be required)			
Ambient temperature <sup>1)</sup> [°C]	0 ... +60			
Protection class to EN 60 529	IP 40			
Noise level F <sub>LEQ</sub> [dB(A)]	62	65	68	69
Corrosion resistance class CRC <sup>2)</sup>	2			

1) Note operating range of proximity sensors

2) Corrosion resistance class 2 according to Festo standard 940 070

Components requiring moderate corrosion resistance. Externally visible parts with primarily decorative surface requirements which are in direct contact with a normal industrial environment or media such as coolants or lubricating agents.

Forces [N]				
Piston Ø	16	20	25	32
Theoretical force at 6 bar, advancing <sup>1)</sup>	121	188	295	483
Theoretical force at 6 bar, returning <sup>1)</sup>	104	158	247	415

1) Theoretical values, please note: Degree of efficiency: approx. 90%

- 2 - Type discontinued  
Available up until 2017

FESTO

## Linear modules HMP

Technical data

Weight [g]		16	20	25	32
Piston Ø					
Product weight	with 0 mm stroke	2100	4700	6300	10900
	per 10 mm stroke	88	110	150	200
Moving load	with 0 mm stroke	900	1500	2300	4000
	per 10 mm stroke	28	37	55	74
End cap	HMP-...-AD	180	270	300	400
	HMP-...-EL	210	300	330	430
Clamping unit HMP-...-KP for effective stroke	50 mm	109	114	-	-
	100 mm	120	125	-	-
	150 mm	131	136	-	-
	200 mm	142	147	-	-
	250 mm	153	158	-	-
	320 mm	168	173	-	-
Intermediate position module	HMP-...-Z1A/Z1E	165	206	227	321

### Materials

Sectional view

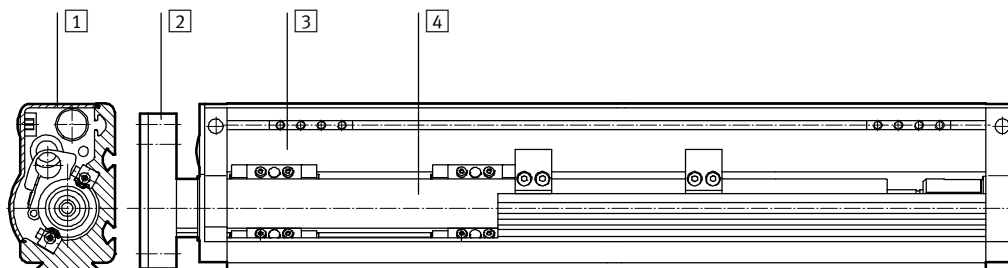

Linear module		
1	Housing cover	Anodised aluminium
2	Yoke plate	Anodised aluminium
3	Profile	Anodised aluminium
4	Guide barrel	Tool steel
-	Seals	Nitrile rubber, polyurethane

**- 1 - Type discontinued**  
**Available up until 2017**

**Linear modules HMP**

Technical data



Permissible torque  $M$  as a function of the stroke length  $l$  (at the yoke plate)

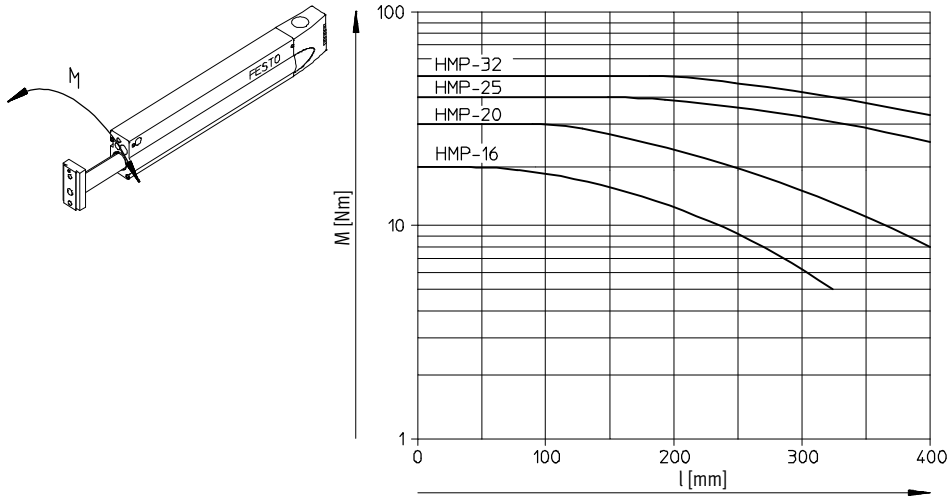

Permissible effective load  $F_q$  as a function of the stroke length  $l$  (at the yoke plate)

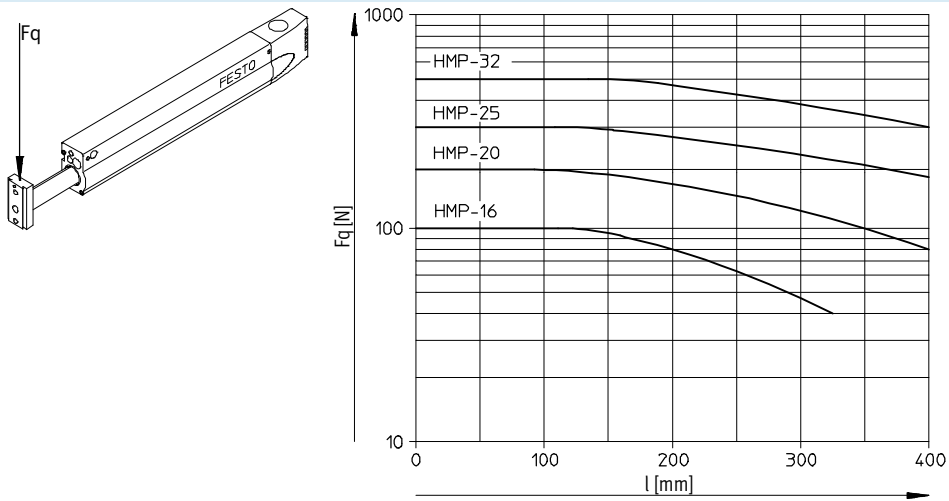

# Linear modules HMP

Technical data

Deflection/deformation  $f$  as a function of the effective load  $m$  and the position  $l$  (stroke)

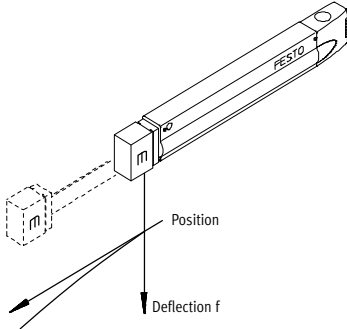

HMP-16

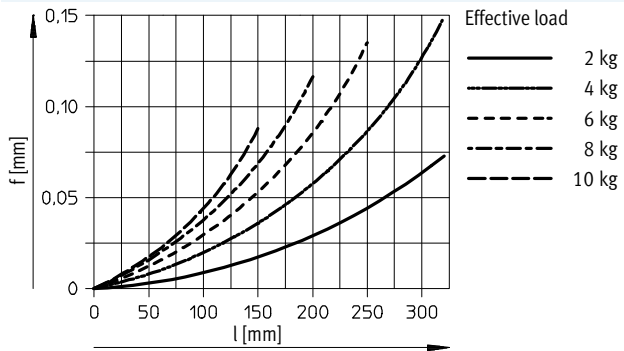

HMP-20

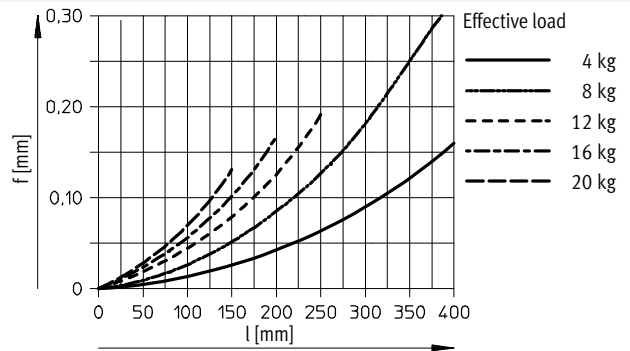

HMP-25

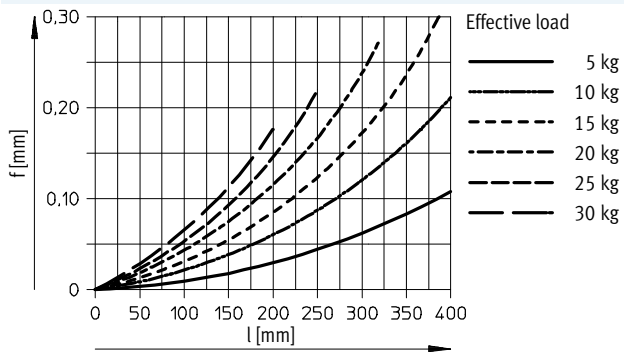

HMP-32

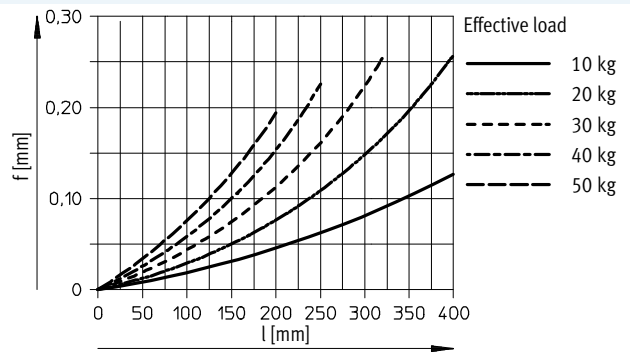

**- 7 - Type discontinued**  
**Available up until 2017**

**Linear modules HMP**

Technical data



Max. permissible horizontal effective load at 6 bar

- HMP-16: 10 kg
- HMP-20: 20 kg
- HMP-25: 30 kg
- HMP-32: 50 kg

Permissible horizontal advancing time  $t$  as a function of the stroke length and the effective load  $m$  with optimum shock absorber stroke

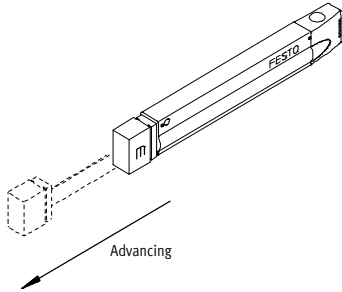

HMP-16<sup>1)</sup>

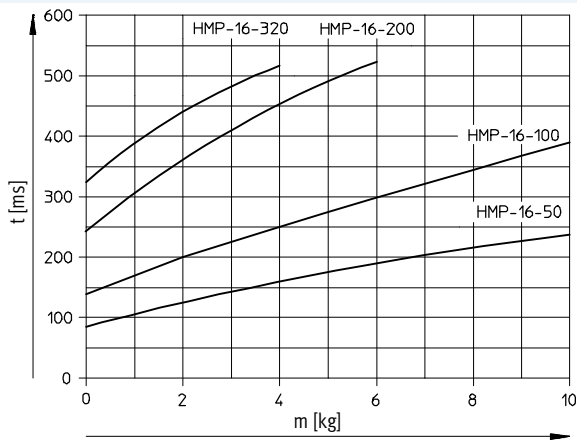

HMP-20<sup>1)</sup>

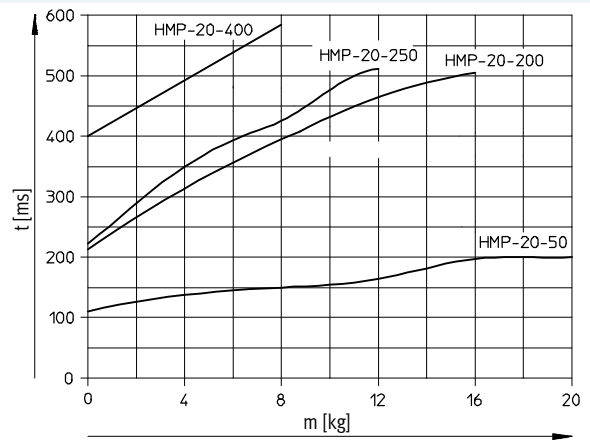

HMP-25<sup>1)</sup>

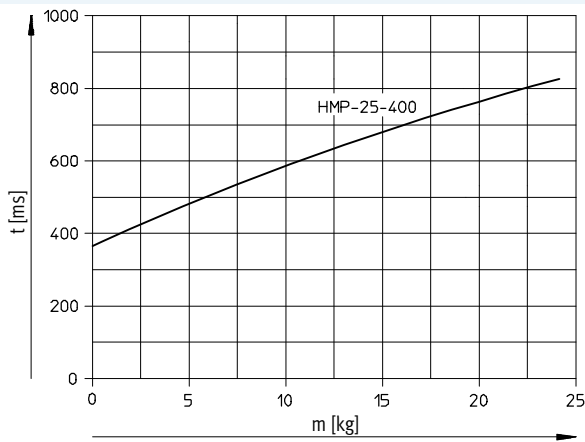

HMP-32<sup>1)</sup>

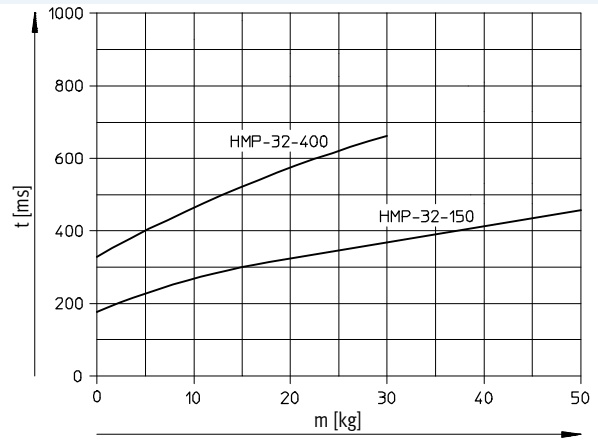

1) Further nominal strokes in preparation

# Linear modules HMP

Technical data

Max. permissible horizontal effective load at 6 bar

HMP-16: 10 kg

HMP-20: 20 kg

HMP-25: 30 kg

HMP-32: 50 kg

Permissible horizontal returning time  $t$  as a function of the stroke length and the effective load  $m$  with optimum shock absorber stroke

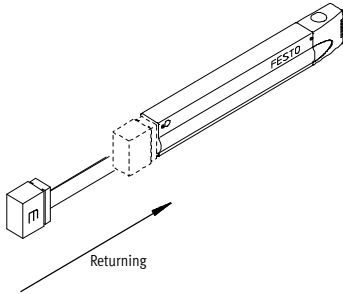

HMP-16<sup>1)</sup>

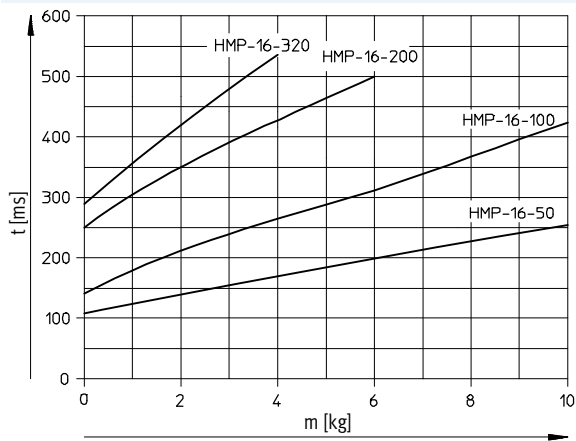

HMP-20<sup>1)</sup>

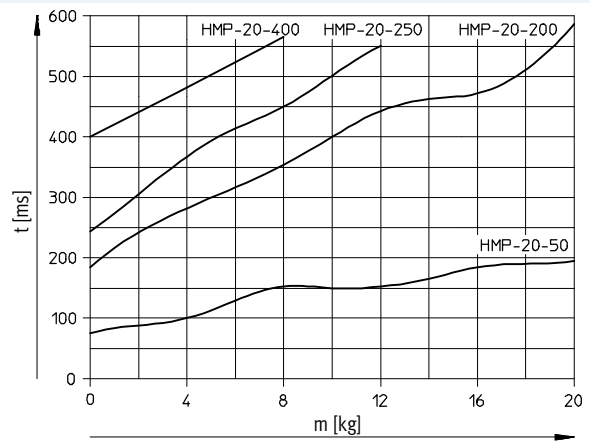

HMP-25<sup>1)</sup>

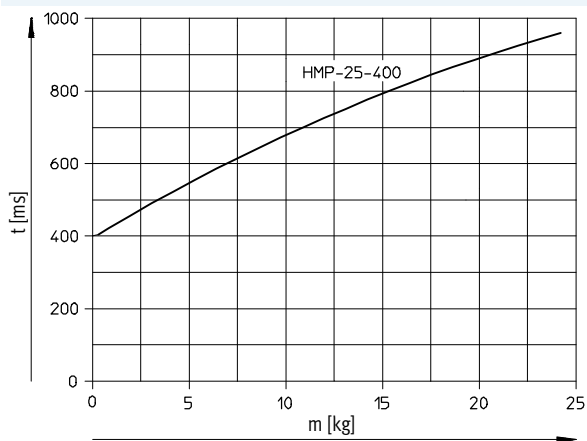

HMP-32<sup>1)</sup>

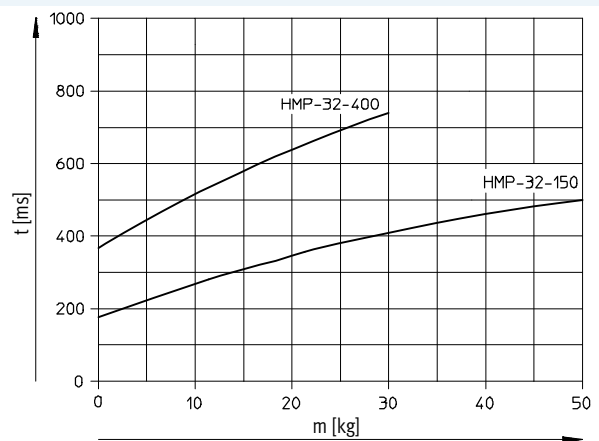

1) Further nominal strokes in preparation

**- 7 - Type discontinued**  
**Available up until 2017**

**Linear modules HMP**

Technical data



**Max. permissible vertical effective load at 6 bar**

without clamping cartridge	with clamping cartridge
HMP-16: 5 kg	HMP-16: 4 kg
HMP-20: 10 kg	HMP-20: 7.5 kg
HMP-25: 15 kg	
HMP-32: 25 kg	

**Permissible vertical advancing time  $t$  as a function of the stroke length and the effective load  $m$  with optimum shock absorber stroke**  
 HMP-16/-20/-25/-32<sup>1)</sup>

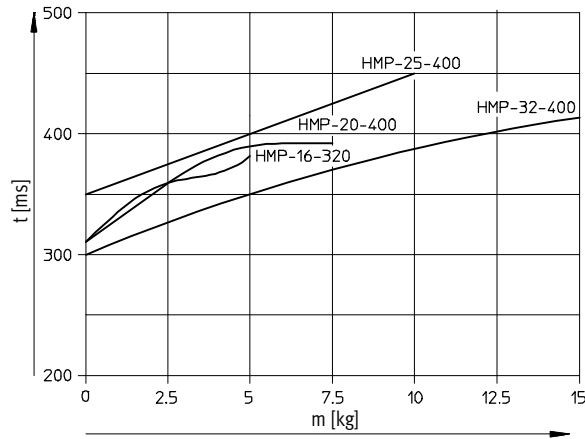
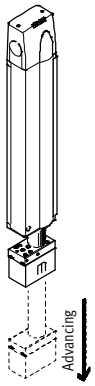

**Permissible vertical returning time  $t$  as a function of the stroke length and the effective load  $m$  with optimum shock absorber stroke**  
 HMP-16/-20/-25/-32<sup>1)</sup>

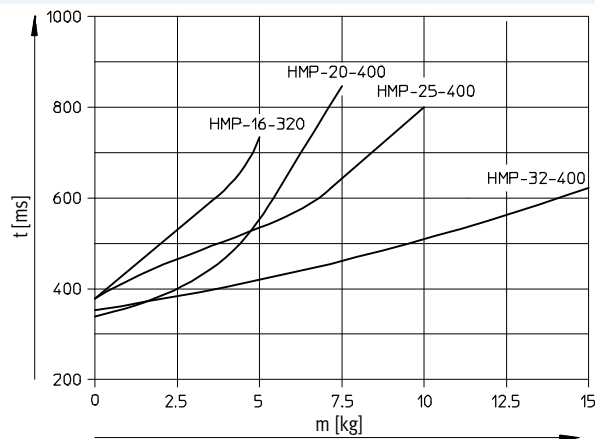
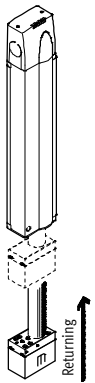

1) Further nominal strokes in preparation



## Linear modules HMP

Technical data

### Advancing/returning time $t$ as a function of the optimum length $L$ to which the shock absorber should be screwed out

In order to obtain the shortest possible travel time with a linear module HMP, it is essential to adjust the shock absorbers to match the advancing/returning time  $t$ .

The optimum length  $L$  to which the shock absorbers should be screwed out is shown in the adjacent graph.

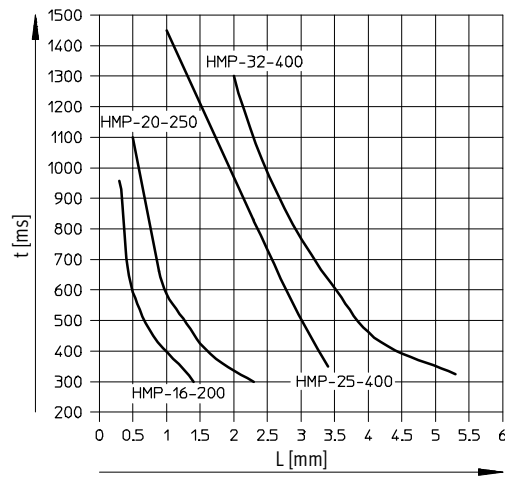
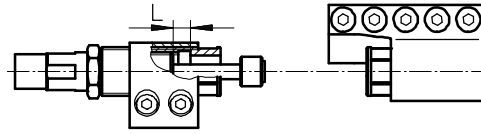

### Determining the permissible effective load

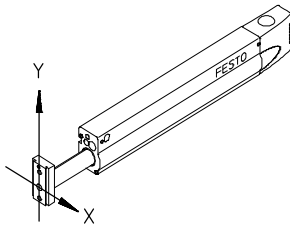

As long as the centre of gravity of the effective load on the yoke plate lies within the outline of this plate, it is impossible to overload the linear module.

Centre of gravity

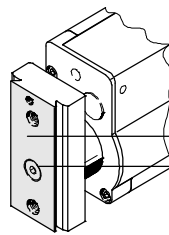

When dovetail mounting components are used, the centre of gravity should be within this area.

Recommended position of centre of gravity for low-vibration operation.

- 7 - Type discontinued  
Available up until 2017

## Linear modules HMP

Technical data

FESTO

### Intermediate position module Z1A/Z1E

Intermediate position with advancing with Z1A

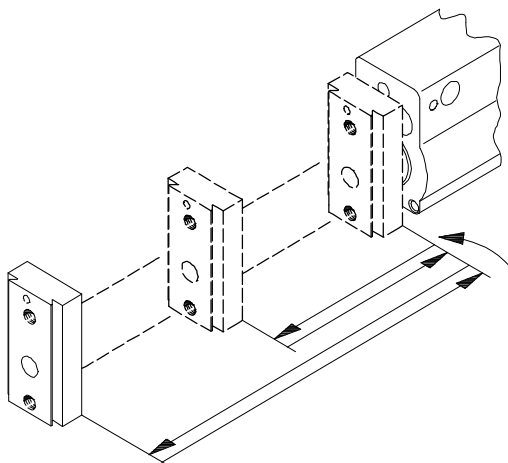

### Range for possible intermediate positions when advancing

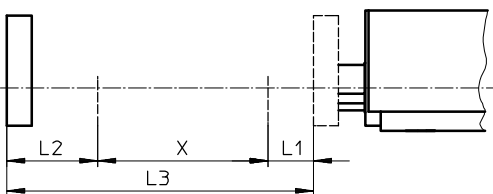

L1 = Rear non-operational zone  
L2 = Front non-operational zone  
L3 = Effective stroke

X = Zone for possible intermediate positions  
X =  $L3 - L1 - L2$

### Non-operational zones [mm]

Piston Ø	16	20	25	32
L1	33	42	42	55.5
L2	66	68.5	54.5	56

### Calculation example

Given:  
Linear module  
HMP-16-200-...-Z1A-...

To be found:  
In which zone of the effective stroke  
are intermediate positions possible?

Calculation:  
The piston Ø of the linear module  
(16 mm) determines the following  
non-operational zones which do not  
permit intermediate positions:  
L1 = 33 mm  
L2 = 66 mm

$$X = L3 - L1 - L2 = 101 \text{ mm}$$

This means:  
The lower limit of the effective stroke  
range for permissible intermediate  
positions is:  
L1 = 33 mm

The upper limit of the effective stroke  
range for permissible intermediate  
positions is:  
L1 + X = 134 mm

-  - Note

Ordering data in the:

- Modular products → 24
- Accessories → 26

## Linear modules HMP

Technical data

### Intermediate position when returning with Z1E

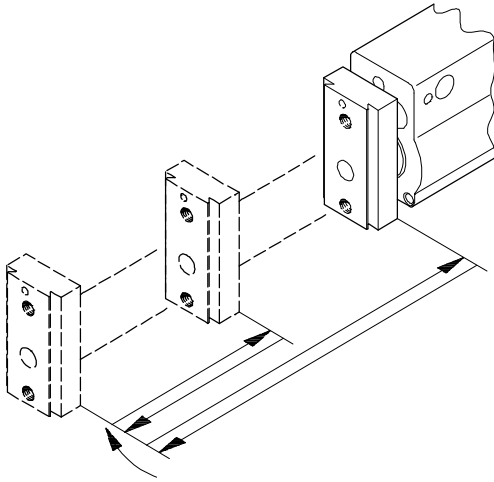

### Range for possible intermediate positions when returning

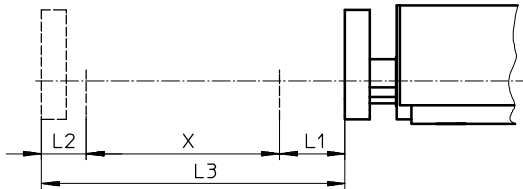

L1 = Rear non-operational zone  
L2 = Front non-operational zone  
L3 = Effective stroke  
X = Zone for possible intermediate positions  
X =  $L3 - L1 - L2$

### Non-operational zones [mm]

Piston $\varnothing$	16	20	25	32
L1	47.5	62	54.5	56
L2	33	42	42	55.5

### Calculation example

Given:  
Linear module  
HMP-16-200-...-Z1E-...

To be found:  
In which zone of the effective stroke  
are intermediate positions possible?

Calculation:  
The piston  $\varnothing$  of the linear module  
(16 mm) determines the following  
non-operational zones which do not  
permit intermediate positions:  
L1 = 47.5 mm  
L2 = 33 mm  
X =  $L3 - L1 - L2 = 119.5$  mm

This means:  
The lower limit of the effective stroke  
range for permissible intermediate  
positions is:  
L1 = 47.5 mm  
The upper limit of the effective stroke  
range for permissible intermediate  
positions is:  
L1 + X = 167 mm

- Note

Ordering data in the:

- Modular products → page 24
- Accessories → page 26

- 1 - Type discontinued  
Available up until 2017

## Linear modules HMP

Technical data

FESTO

### Dimensions

Piston  $\varnothing$  16/20 mm

Download CAD data → [www.festo.com](http://www.festo.com)

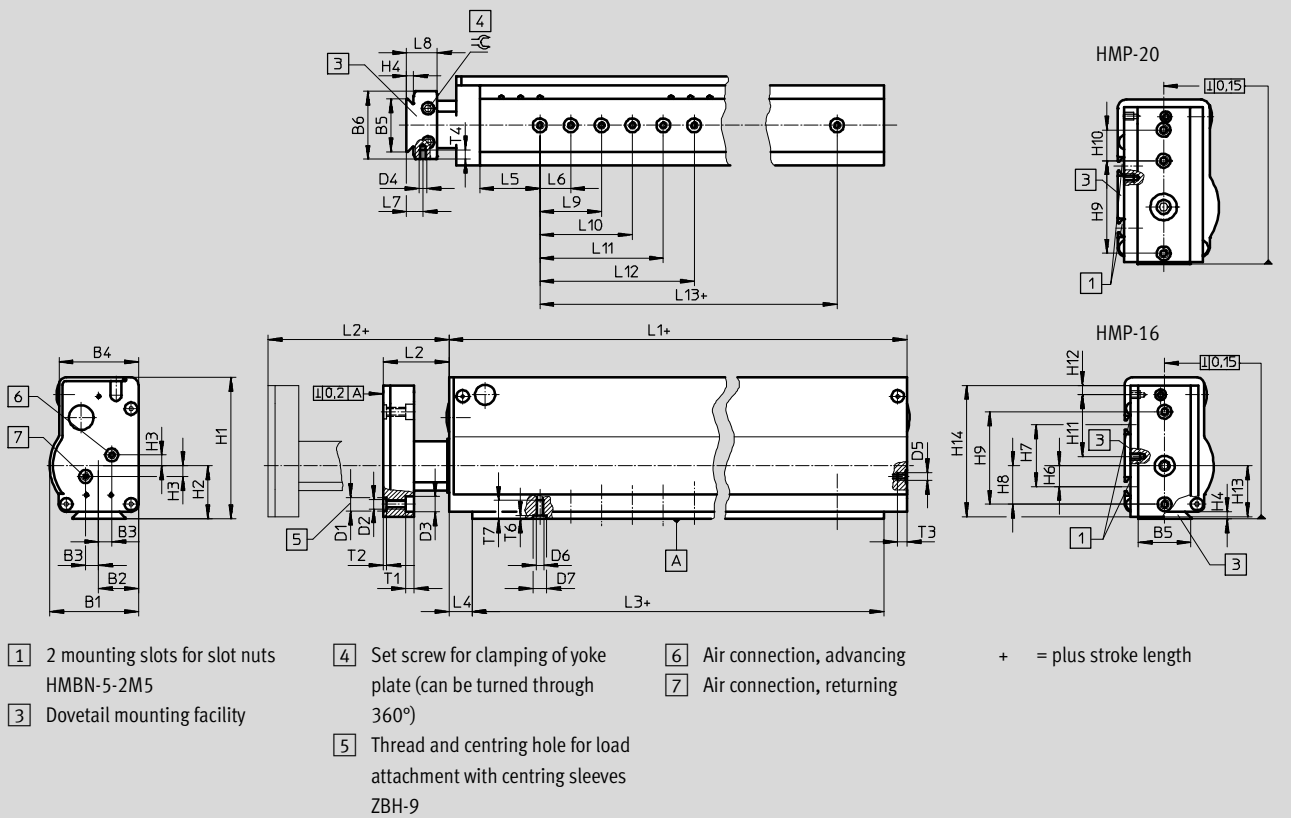

Type	B1	B2	B3	B4	B5	B6	D1	D2	D3	D4	D5	D6	D7	H1	H2	H3
			±0.1				$\varnothing$ H7		$\varnothing$ H13				$\varnothing$ H7			±0.1
HMP-16	57.8	26	8.5	51.7	34	44	9	M6	10	M5	M5	M5	9	92	34.5	7
HMP-20	65.8	30	10	59.8		51					G1/8					

Type	H4	H6	H7	H8	H9	H10	H11	H12	H13	H14	H17	L1	L2	L3	L4
					±0.03 <sup>1)</sup>	±0.03 <sup>1)</sup>									+0.2
HMP-16	4.5	13.5	40	25	60	-	40	6	33	85	38	247	23	217	15
HMP-20				30		20			35.5						

Type	L5	L6	L7	L8	L9	L10	L11	L12	L13	T1	T2	T3	T4	T6	T7	≡
		±0.03		+0.2	±0.03	±0.03	±0.03	±0.03	±0.03		+0.1			+0.1		
HMP-16	39	20	10.75	20	40	60	80	100	140	5.7	2.1	6.4	6	2.1	12	4
HMP-20	45								200			9				

1) Tolerance specification applies to countersink D1; tolerance for thread D2: ±0.2

- Type discontinued  
Available up until 2017

FESTO

# Linear modules HMP

Technical data

## Dimensions

Piston  $\varnothing$  25/32 mm

Download CAD data → [www.festo.com](http://www.festo.com)

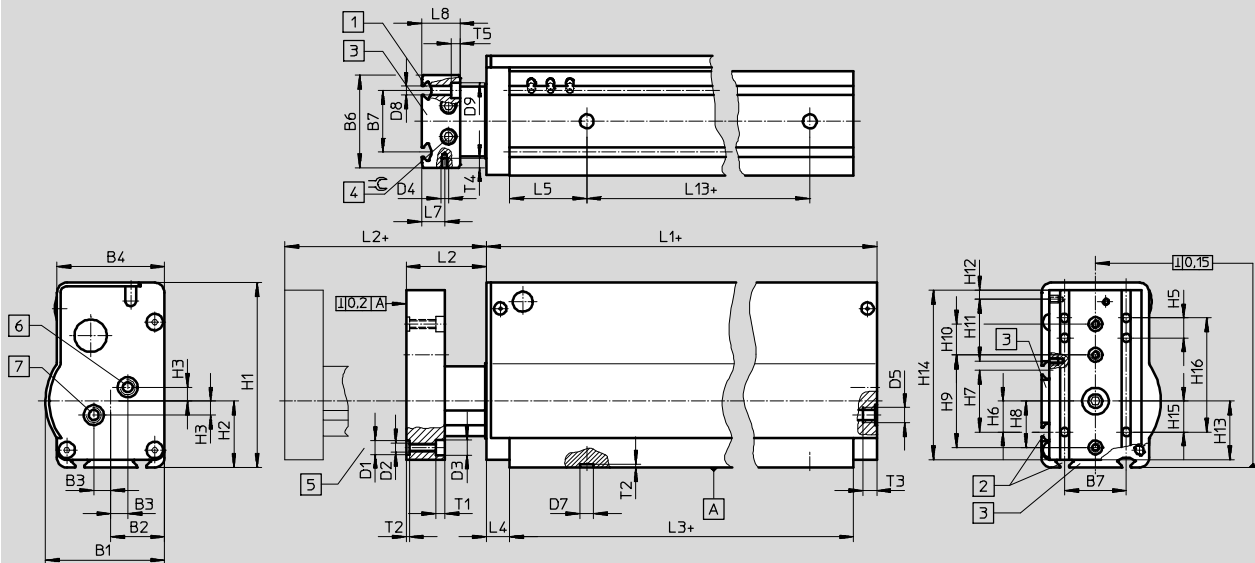

- 1 2 mounting slots for slot nuts HMBN-5-2M5
  - 2 4 mounting slots for slot nuts HMBN-5-2M5
  - 3 Dovetail mounting facility
  - 4 Set screw for clamping of yoke plate (can be turned through 360°)
  - 5 Thread and centring hole for load attachment with centring sleeves ZBH-9
  - 6 Air connection, advancing
  - 7 Air connection, returning
- + = plus stroke length

Type	B1	B2	B3	B4	B6	B7	D1	D2	D3	D4	D5	D7	D8	D9
			±0.1				$\varnothing$ H7		$\varnothing$ H13			$\varnothing$ H7	$\varnothing$ H13	$\varnothing$
HMP-25	77.3	35	11	69.8	60	40	9	M6	10	M5	G1/8	9	5.5	10
HMP-32	90.8	40		79.8	70						G1/4			

Type	H1	H2	H3	H5	H6	H7	H8	H9	H10	H11	H12	H13	H14	H15	H16
			±0.1					±0.03 <sup>1)</sup>	±0.03 <sup>1)</sup>						
HMP-25	120	43	9	13	20	40	30	60	20	40	6	38	110	20	74
HMP-32	143	53					40	80				48	133	30	

Type	H17	L1	L2	L3	L4	L5	L7	L8	L13	T1	T2	T3	T4	T5	$\approx$
					+0.2			±0.2	±0.03		+0.1				
HMP-25	40	320	28	290	15	50	15	25	190	5.7	2.1	9	6	5.7	5
HMP-32		427		392					290			12			

1) Tolerance specification applies to countersink D1; tolerance for thread D2: ±0.2

- 7 - Type discontinued  
Available up until 2017

## Linear modules HMP

Technical data

FESTO

### Dimensions – Pneumatic connections (code 2G3/2G4/2G6)

Download CAD data → [www.festo.com](http://www.festo.com)

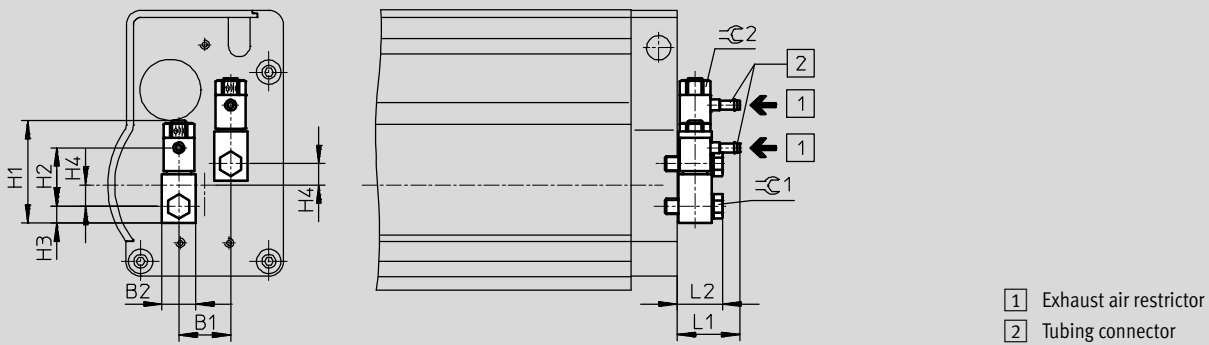

Type	B1	B2	H1	H2	H3	H4	L1	L2	≡C1	≡C2
HMP-16-...-2G3	17	11	33.6	19	5.5	7	20.6	15	7	9
HMP-16-...-2G4				22.6						
HMP-20-...-2G4	20	16	48.7	28.9	8	9	31.3	22.2	13	14
HMP-20-...-2G6				27.5			31.4			
HMP-25-...-2G4	22	20	61.8	28.9	10	9	31.3	28.2	17	17
HMP-25-...-2G6				27.5			31.4			
HMP-32-...-2G4				37.9			35.8			
HMP-32-...-2G6				38.2			35.9			

### Dimensions – Clamping unit (code KP)

Download CAD data → [www.festo.com](http://www.festo.com)

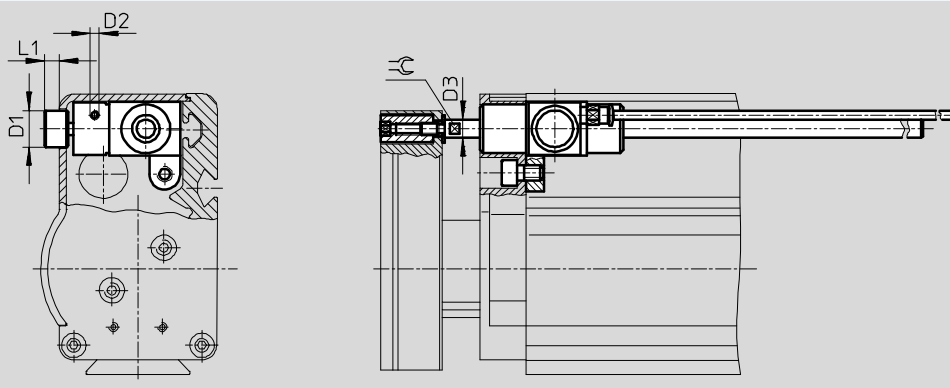

Type	D1 ∅	D2 1)	D3 ∅	L1	≡C	Holding force [N]	Effective load	
							horizontal [kg]	vertical [kg]
HMP-16	11.4	M3	6	5	5	100	10	4
HMP-20				3.8			20	7.5

1) Air connection is supplied ready-fitted with QS connector QSM-M3-4

### - 8 - Note

The clamping unit must only be operated when the rod is stationary (end position). Dynamic braking operations can result in severe damage to the clamping device.

Precision positioning cannot be guaranteed with the clamping unit since slippage of approx. 1 – 2 mm can occur.

When using the linear module HMP-20 together with the clamping unit, the max. possible stroke is reduced by 12.5 mm.

- 2 - Type discontinued  
Available up until 2017

# Linear modules HMP

Technical data

## Dimensions – Intermediate position modules

Download CAD data → [www.festo.com](http://www.festo.com)

(code Z1A/Z1E)

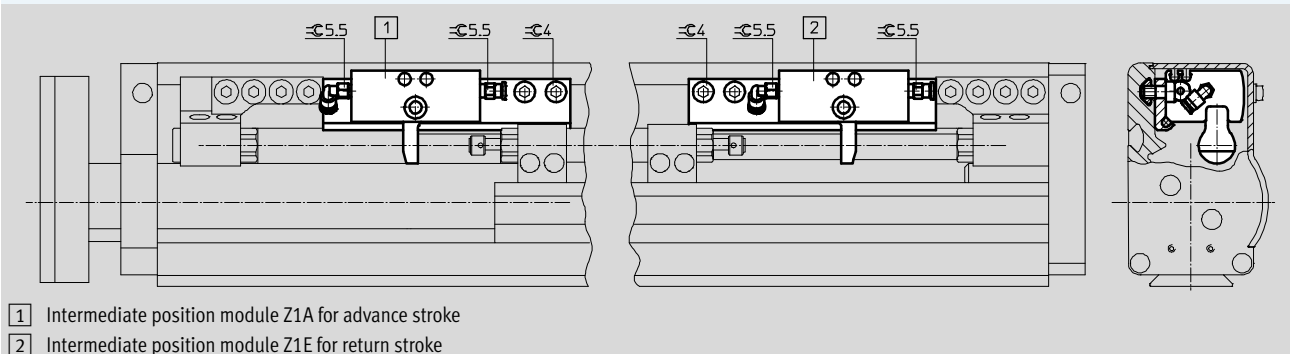

## Dimensions – End cap

Download CAD data → [www.festo.com](http://www.festo.com)

(code AD/EL)

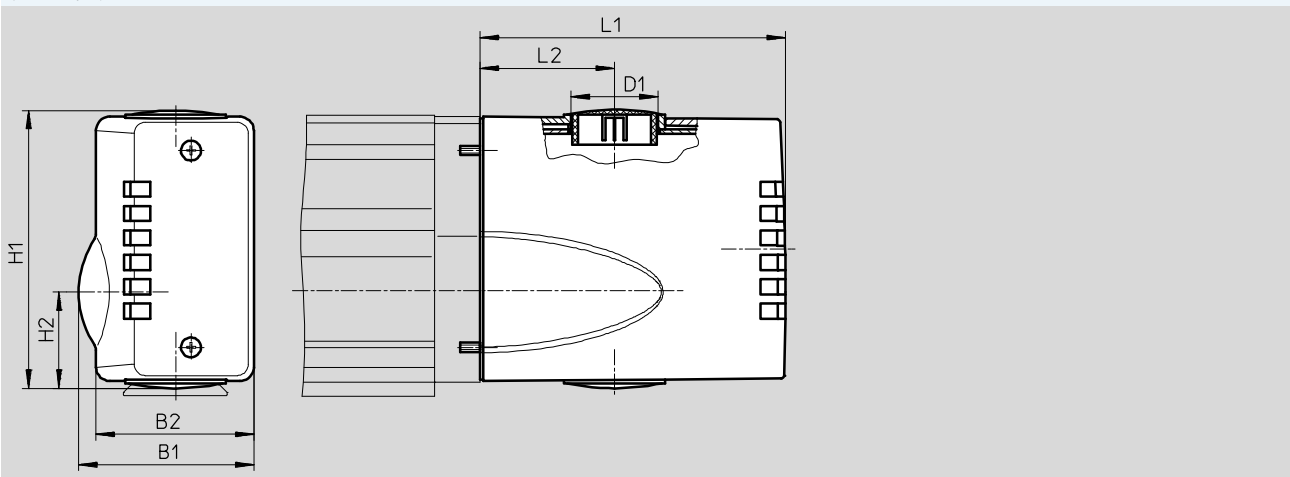

Type	B1	B2	D1 ∅	H1	H2	L1	L2
HMP-16	57.4	51.2	28.5 (PG 21)	91.3	31.5	100	44
HMP-20	65.4	59.2	37.2 (PG 29)	106.3	34.4	120	55
HMP-25	76.9	69.2		119	40.1		
HMP-32	90.4	79.2		141.6	49.9		

**- 1 - Type discontinued**  
**Available up until 2017**

## Linear modules HMP

Ordering data – Modular products



**M** Mandatory data →

Module No.	Function	Piston Ø	Stroke	Generation	Position sensing	Pneumatic connection
537940	HMP	16	50	B	SL	2G3
537941		20	100			2G4
537942		25	150			2G6
537943		32	200			
						250
			320			
			400			
<b>Ordering example</b>						
<b>537940</b>	<b>HMP</b>	<b>- 16</b>	<b>- 150</b>	<b>- B</b>	<b>- SL</b>	<b>- 2G3</b>

**Ordering table**

Size	16	20	25	32	Condi- tions	Code	Enter code
<b>M</b> Module No.	<b>537940</b>	<b>537941</b>	<b>537942</b>	<b>537943</b>			
Function	Linear module with ball bearing guide					<b>HMP</b>	HMP
Piston Ø [mm]	16	20	25	32		-...	
Stroke [mm]	50	50	-	-		<b>-50</b>	
	100	100	100	100		<b>-100</b>	
	150	150	150	150		<b>-150</b>	
	200	200	200	200		<b>-200</b>	
	250	250	250	250		<b>-250</b>	
	320	320	320	320		<b>-320</b>	
	-	400	400	400		<b>-400</b>	
Generation	B series					<b>-B</b>	-B
Position sensing	Sensor strip					<b>-SL</b>	-SL
Pneumatic connection	One-way flow control valve, 3 mm barbed connector	-	-	-		<b>-2G3</b>	
	One-way flow control valve, 4 mm barbed connector					<b>-2G4</b>	
	-	One-way flow control valve, 6 mm barbed connector				<b>-2G6</b>	

Transfer order code

**HMP** -  -  - **B** -  - **SL** -



- 2 - Type discontinued  
Available up until 2017

FESTO

## Linear modules HMP

Ordering data – Modular products

### Options

Clamping unit	Intermediate position	Interface	Proximity sensor set	User documentation	Accessories	Cable with socket	Slot cover	Centring sleeves
KP	Z1A Z1E	AD EL	A1 A2 A3 A4 A5 A6	E S F I V B	ZUB	...V	A	...Z
-	- <b>Z1A</b>	- <b>EL</b>	- <b>A1</b>	- <b>B</b>	<b>ZUB</b>	- <b>2V</b>		

### Ordering table

Size	16	20	25	32	Condi- tions	Code	Enter code
0 Clamping unit	Attached				1	-KP	
Intermediate position	1 intermediate position, advancing				2	-Z1A	
	1 intermediate position, returning				2	-Z1E	
Interface	End cap					-AD	
	End cap with electrical interface					-EL	
Proximity sensor, assembled	Proximity sensor with cable, 2.5 m					-A1	
	Proximity sensor, contactless, NPN with cable, 2.5 m					-A2	
	Proximity sensor, contactless, PNP with cable, 2.5 m					-A3	
	Proximity sensor with plug M8				3	-A4	
	Proximity sensor, contactless, NPN with plug M8				3	-A5	
	Proximity sensor, contactless, PNP with plug M8				3	-A6	
Alternative user documentation (standard is German/English)	User documentation, English					-E	
	User documentation, Spanish					-S	
	User documentation, French					-F	
	User documentation, Italian					-I	
	User documentation, Swedish					-V	
	Express waiver - no manual to be included (already available)					-B	
Accessories	Supplied separately					ZUB-	ZUB-
Cable with socket, 2.5 m	1 ... 10					...V	
Slot cover	Slot cover					A	
Centring sleeves (pack of 10)	10, 20, 30, 40, 50, 60, 70, 80, 90					...Z	

1 KP Not with intermediate position Z1A, Z1E.

2 Z1A, Z1E Min. stroke: 150 mm.

3 A4, A5, A6 Not with interface EL

Max. stroke: Piston Ø 16, 20, 25 mm: 200 mm  
Piston Ø 32 mm: 150 mm

### Transfer order code



-  -  -  -  -  **ZUB** -

**- 1 - Type discontinued**  
**Available up until 2017**

## Linear modules HMP

Accessories

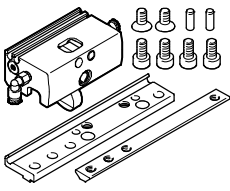
**FESTO**

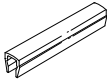
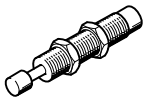
Ordering data						
	For piston $\varnothing$ [mm]	Remarks	Order code	Part No.	Type	PU <sup>1)</sup>
<b>Intermediate position module BZ1-HMP</b>						
	16	For advance movement	Z1A	<b>538904</b>	<b>BZ1-HMP-16-B-Z1A</b>	1
	20			<b>538905</b>	<b>BZ1-HMP-20-B-Z1A</b>	
	25			<b>538906</b>	<b>BZ1-HMP-25-B-Z1A</b>	
	32			<b>538907</b>	<b>BZ1-HMP-32-B-Z1A</b>	
	16	For return movement	Z1E	<b>538908</b>	<b>BZ1-HMP-16-B-Z1E</b>	
	20			<b>539909</b>	<b>BZ1-HMP-20-B-Z1E</b>	
	25			<b>538910</b>	<b>BZ1-HMP-25-B-Z1E</b>	
	32			<b>538911</b>	<b>BZ1-HMP-32-B-Z1E</b>	
<b>Centring sleeve ZBH</b> <span style="float: right;">Technical data → Internet: zbh</span>						
	16 ... 32	For yoke plate	Z	<b>150927</b>	<b>ZBH-9</b>	10
<b>Slot cover ABP</b>						
	16 ... 32	For sensor strip every 0.5 m	A	<b>151681</b>	<b>ABP-5</b>	2
<b>Shock absorber YSRW</b> <span style="float: right;">Technical data → Internet: ysrw</span>						
	16	-	-	<b>191194</b>	<b>YSRW-8-14</b>	1
	20			<b>191196</b>	<b>YSRW-12-20</b>	
	25			<b>191196</b>	<b>YSRW-12-20</b>	
	32			<b>191197</b>	<b>YSRW-16-26</b>	



1) Packaging unit quantity

# Linear modules HMP

Accessories

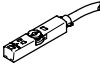
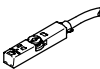
FESTO

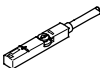
Ordering data – Proximity sensors for T-slot, magneto-resistive						Technical data → Internet: smt	
	Type of mounting	Switch output	Electrical connection	Cable length [m]	Part No.	Type	
<b>N/O contact</b>							
	Insertable in the slot from above, flush with cylinder profile, short design	PNP	Cable, 3-wire	2.5	<b>574335</b>	<b>SMT-8M-A-PS-24V-E-2,5-OE</b>	
			Plug M8x1, 3-pin	0.3	<b>574334</b>	<b>SMT-8M-A-PS-24V-E-0,3-M8D</b>	
			Plug M12x1, 3-pin	0.3	<b>574337</b>	<b>SMT-8M-A-PS-24V-E-0,3-M12</b>	
		NPN	Cable, 3-wire	2.5	<b>574338</b>	<b>SMT-8M-A-NS-24V-E-2,5-OE</b>	
			Plug M8x1, 3-pin	0.3	<b>574339</b>	<b>SMT-8M-A-NS-24V-E-0,3-M8D</b>	
<b>N/C contact</b>							
	Insertable in the slot from above, flush with cylinder profile, short design	PNP	Cable, 3-wire	7.5	<b>574340</b>	<b>SMT-8M-A-PO-24V-E-7,5-OE</b>	



Ordering data – Proximity sensors for T-slot, magnetic reed						Technical data → Internet: sme		
	Type of mounting	Switch output	Electrical connection	Cable length [m]	Part No.	Type		
<b>N/O contact</b>								
	Insertable in the slot from above, flush with cylinder profile	Contacting	Cable, 3-wire	2.5	<b>543862</b>	<b>SME-8M-DS-24V-K-2,5-OE</b>		
				5.0	<b>543863</b>	<b>SME-8M-DS-24V-K-5,0-OE</b>		
			Plug M8x1, 3-pin	Cable, 2-wire	2.5	<b>543872</b>	<b>SME-8M-ZS-24V-K-2,5-OE</b>	
				0.3	<b>543861</b>	<b>SME-8M-DS-24V-K-0,3-M8D</b>		
	Insertable in the slot lengthwise, flush with the cylinder profile	Contacting	Cable, 3-wire	2.5	<b>150855</b>	<b>SME-8-K-LED-24</b>		
			Plug M8x1, 3-pin	0.3	<b>150857</b>	<b>SME-8-S-LED-24</b>		
<b>N/C contact</b>								
	Insertable in the slot lengthwise, flush with the cylinder profile	Contacting	Cable, 3-wire	7.5	<b>160251</b>	<b>SME-8-O-K-LED-24</b>		



# Linear modules HMP

Accessories

FESTO

Ordering data – Proximity sensors for C-slot, magneto-resistive						Technical data → Internet: smt
	Type of mounting	Switch output	Electrical connection, connection direction	Cable length [m]	Part No.	Type
N/O contact						
	Insertable in the slot from above	PNP	Cable, 3-wire, in-line	2.5	<b>551373</b>	<b>SMT-10M-PS-24V-E-2,5-L-OE</b>
			Plug M8x1, 3-pin, in-line	0.3	<b>551375</b>	<b>SMT-10M-PS-24V-E-0,3-L-M8D</b>
			Plug M8x1, 3-pin, lateral	0.3	<b>551376</b>	<b>SMT-10M-PS-24V-E-0,3-Q-M8D</b>

Ordering data – Proximity sensors for C-slot, magnetic reed						Technical data → Internet: sme
	Type of mounting	Switch output	Electrical connection, connection direction	Cable length [m]	Part No.	Type
N/O contact						
	Insertable in the slot from above	Contacting	Plug M8x1, 3-pin, in-line	0.3	<b>551367</b>	<b>SME-10M-DS-24V-E-0,3-L-M8D</b>
			Cable, 3-wire, in-line	2.5	<b>551365</b>	<b>SME-10M-DS-24V-E-2,5-L-OE</b>
			Cable, 2-wire, in-line	2.5	<b>551369</b>	<b>SME-10M-ZS-24V-E-2,5-L-OE</b>
	Insertable in the slot lengthwise	Contacting	Plug M8x1, 3-pin, in-line	0.3	<b>173212</b>	<b>SME-10-SL-LED-24</b>
			Cable, 3-wire, in-line	2.5	<b>173210</b>	<b>SME-10-KL-LED-24</b>

Ordering data – Connecting cables					Technical data → Internet: nebu
	Electrical connection, left	Electrical connection, right	Cable length [m]	Part No.	Type
	Straight socket, M8x1, 3-pin	Cable, open end, 3-wire	2.5	<b>541333</b>	<b>NEBU-M8G3-K-2.5-LE3</b>
			5	<b>541334</b>	<b>NEBU-M8G3-K-5-LE3</b>
	Straight socket, M12x1, 5-pin	Cable, open end, 3-wire	2.5	<b>541363</b>	<b>NEBU-M12G5-K-2.5-LE3</b>
			5	<b>541364</b>	<b>NEBU-M12G5-K-5-LE3</b>
	Angled socket, M8x1, 3-pin	Cable, open end, 3-wire	2.5	<b>541338</b>	<b>NEBU-M8W3-K-2.5-LE3</b>
			5	<b>541341</b>	<b>NEBU-M8W3-K-5-LE3</b>
	Angled socket, M12x1, 5-pin	Cable, open end, 3-wire	2.5	<b>541367</b>	<b>NEBU-M12W5-K-2.5-LE3</b>
			5	<b>541370</b>	<b>NEBU-M12W5-K-5-LE3</b>

# Linear modules HMP

Accessories



**Adapter kit**  
DHAA, HMAV, HMSV

Material:  
Wrought aluminium alloy  
Free of copper and PTFE  
RoHS-compliant

 Note  
The kit includes the individual mounting interface as well as the necessary mounting material.

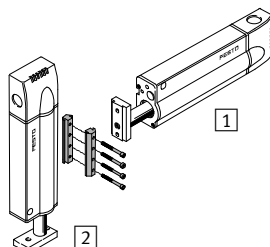
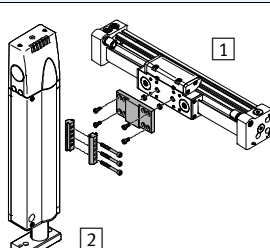
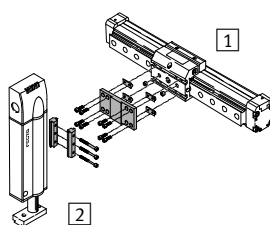
Permissible drive/drive combinations with adapter kit				Download CAD data → <a href="http://www.festo.com">www.festo.com</a>			
Combination	[1] Drive	[2] Drive	Adapter kit				
	Size	Size	CRC <sup>1)</sup>	Part No.	Type	Required quantity	PU <sup>2)</sup>
	HMP	HMP	HMSV				
	Direct mounting						
	16	16	2	–	M5x25 DIN 912 <sup>3)</sup>	2	–
				150927	ZBH-9 <sup>3)</sup>	2	10
	20	16, 20		–	M5x25 DIN 912 <sup>3)</sup>	3	–
				150927	ZBH-9 <sup>3)</sup>	3	10
	25, 32	16, 20		–	M5x30 DIN 912 <sup>3)</sup>	3	–
				150927	ZBH-9 <sup>3)</sup>	3	10
	25	25		177652	HMSV-6	–	–
	32	25, 32		177652	HMSV-6	–	–
	Dovetail mounting						
	16, 20, 25	16	2	177647	HMSV-1	1	1
	20	20		177649	HMSV-3	1	1
	25	20, 25		177649	HMSV-3	1	1
32	16	177649		HMSV-3	1	1	
32	20, 25, 32	177653		HMSV-7	1	1	
DGC/HMP	DGC	HMP	DHAA, HMAV				
	25	16, 20	2	176005	HMAV-DL25	1	1
	32	16, 20		562150	DHAA-D-L-32-H2	1	1
	40	20, 25, 32		562151	DHAA-D-L-40-H2	1	1
DGP(l)L, DGE/HMP	DG...	HMP	HMAV				
	25	16, 20	2	176005	HMAV-DL25	1	1
	32	16, 20, 25		176006	HMAV-DL32	1	1
	40	20, 25, 32		176007	HMAV-DL40	1	1

- 1) Corrosion resistance class CRC 2 to Festo standard FN 940070  
Moderate corrosion stress. Indoor applications in which condensation may occur. External visible parts with primarily decorative requirements for the surface and which are in direct contact with the ambient atmosphere typical for industrial applications.
- 2) Packaging unit quantity
- 3) The screws and centring sleeves listed are not included in the scope of delivery of the drives

# Linear modules HMP

Accessories



**Adapter kit**  
**DHAA, HMAV**

Material:  
Wrought aluminium alloy  
Free of copper and PTFE  
RoHS-compliant

 Note  
The kit includes the individual mounting interface as well as the necessary mounting material.

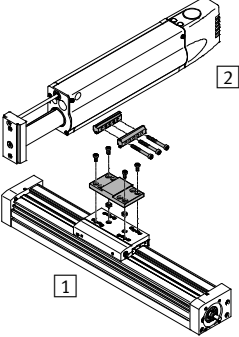
Permissible drive/drive combinations with adapter kit			Download CAD data → <a href="http://www.festo.com">www.festo.com</a>				
Combination	[1] Drive	[2] Drive	Adapter kit			Required quantity	PU <sup>2)</sup>
	Size	Size	CRC <sup>1)</sup>	Part No.	Type		
EGC/HMP	EGC	HMP	DHAA, HMAV				
	80	16, 20	2	<b>176005</b>	<b>HMAV-DL25</b>	1	1
	120	20, 25, 32		<b>562151</b>	<b>DHAA-D-L-40-H2</b>	1	1

- 1) Corrosion resistance class CRC 2 to Festo standard FN 940070  
Moderate corrosion stress. Indoor applications in which condensation may occur. External visible parts with primarily decorative requirements for the surface and which are in direct contact with the ambient atmosphere typical for industrial applications.
- 2) Packaging unit quantity