

Toothed belt axis ELGC-TB

FESTO

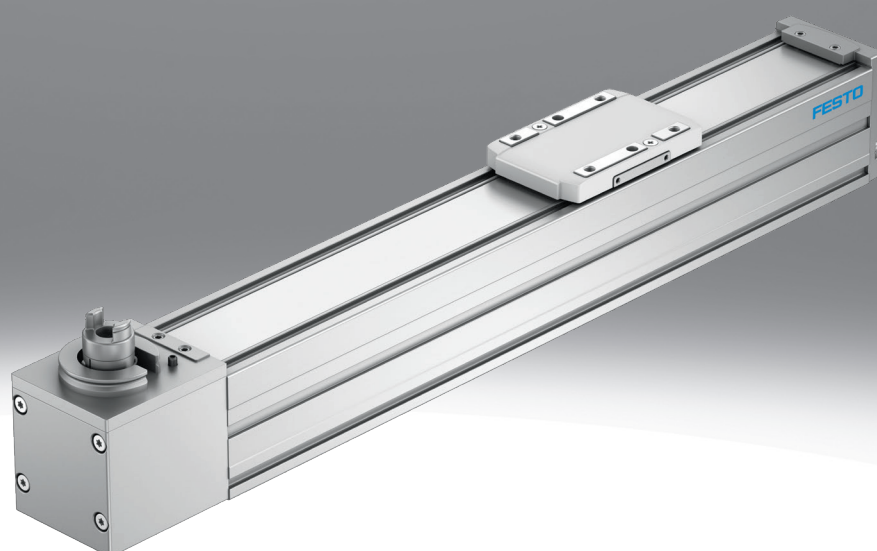

Characteristics

At a glance

Further information → [elgc-tb](#)

- Optimal installation space to working space ratio
- Protected against external influences by internal guide
- Unique mounting system enables the spindle axis ELGC and mini slide EGSC to be combined without using an adapter
- Compact double bearing integrated in the axis to save space
- Stainless steel cover strip kept in place with magnetic strips
- Wide range of mounting options for optimal machine integration
- Suitable for the production of Li-ion batteries

Sealing air connection

- Air is exchanged between the interior of the cylinder and the environment via a sealing air connection. This prevents negative pressure or excess pressure from developing in the cylinder interior.
- Application of slight negative pressure prevents the emission of particles
- Application of slight overpressure prevents the immission of particles

Product segmentation



Festo Core Range

Solves the majority of your automation tasks

With the Festo Core Range, we have selected the most important products and functions from our broad product catalogue, and added the quickest delivery. The Core Range offers you the best value with the expected high Festo quality.

- Quickest delivery, worldwide – wherever, whenever
- Expected high Festo quality
- Easy and fast to select

Engineering tools

Further information → [electric-motion-sizing](#)



Save time with engineering tools Smart Engineering for the optimal solution. Our goal is to increase your productivity. Our engineering tools play an integral part in this. They help you size your system correctly, tap into unimagined productivity reserves and generate additional productivity along the entire value chain. In every phase of your project, from the initial contact to the modernisation of your machine, you will come across a number of different tools which will be of use to you.

Electric Motion Sizing

- Create the optimum drive package quickly and reliably. Electric Motion Sizing calculates suitable combinations of electric axis, electric motor and servo drive using just a few application details. It provides all the relevant data including the bill of materials and documentation for your selected combination. This avoids design errors and results in significantly improved energy efficiency for the system. A smooth connection to the Festo Automation Suite also makes commissioning easier for you.

Diagrams

Further information → [elgc-tb](#)



The diagrams shown in this document are also available online. These can be used to display precise values.

Drive system

[TB] Toothed belt

- For applications where a high dynamic response and short positioning times are required
- For long strokes
- For lower loads
- Low noise

Characteristics

Guide

- Very sturdy and precise guiding principle for transmitting the drive force and moving additional loads
- The guide can easily absorb high torques and forces

Overview

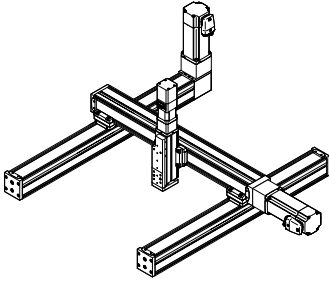

- From the individual axis to the handling system, such as a cantilever system, planar surface gantry or three-dimensional gantry
- The toothed belt and spindle axes ELGC and mini slides EGSC form a scalable modular system for compact automation systems
- The common platform architecture provides an integrated range with matching interfaces. A large number of systems can be implemented completely without adapter plates
- High-performance drive and guide elements ensure a long service life as well as excellent load-bearing capacity and reliability
- The uniform and universal range of accessories reduces warehousing and design costs

Type code

001	Series
ELGC	Gantry axis

002	Drive system
TB	Toothed belt

003	Guide
KF	Recirculating ball bearing guide

004	Size
45	45
60	60
80	80

005	Stroke [mm]
200	200
300	300
500	500
600	600
800	800
1000	1000
1200	1200
1500	1500
1800	1800
2000	2000

Datasheet

General technical data			
Size	45	60	80
Design	Electromechanical linear axis, With toothed belt		
Guide	Recirculating ball bearing guide		
Mounting position	optional		
Working stroke	200 mm; 300 mm; 500 mm; 600 mm; 800 mm; 1,000 mm; 1,200 mm; 1,500 mm	200 mm; 300 mm; 500 mm; 600 mm; 800 mm; 1,000 mm; 1,200 mm; 1,500 mm; 1,800 mm; 2,000 mm	
Max. feed force F _x	75 N	120 N	250 N
Frictional torque independent of load	0.075 Nm	0.194 Nm	0.413 Nm
Max. idle running transfer resistance	7.8 N	15.6 N	24.7 N
Max. drive torque	0.716 Nm	1.49 Nm	4.178 Nm
Max. speed	1.2 m/s	1.5 m/s	
Max. acceleration	15 m/s ²		
Repetition accuracy	±0.1 mm		
Position detection	Via proximity switch, Via inductive sensors		

Operating and ambient conditions	
Ambient temperature ¹⁾	0 ... 50°C
Degree of protection	IP40
Duty cycle	100%
Cleanroom class	Class 7 according to ISO 14644-1
Maintenance interval	Life-time lubrication

1) Note operating range of the proximity switches

Weight			
Size	45	60	80
Basic weight for 0 mm stroke ¹⁾	760 g	1,775 g	3,500 g
Additional weight per 10 mm stroke	23 g	43 g	73 g
Moving mass	169 g	482 g	901 g

1) Incl. slide

Toothed belt			
Size	45	60	80
Toothed-belt pitch	2 mm	3 mm	
Effective diameter of drive pinion	19.1 mm	24.83 mm	33.42 mm
Feed constant	60 mm/U	78 mm/U	105 mm/U

Mass moments of inertia

$$J_A = J_O + J_H \cdot l + J_L \cdot m$$

The mass moment of inertia J of the spindle axis is calculated as follows.

l = working stroke

m = moving payload

Size	45	60	80
Mass moment of inertia J _O	0.186 kgcm ²	0.88 kgcm ²	2.912 kgcm ²
Mass moment of inertia J _H per metre of stroke	0.028 kgcm ²	0.085 kgcm ²	0.193 kgcm ²
Mass moment of inertia J _L per kg of working load	0.912 kgcm ²	1.541 kgcm ²	2.793 kgcm ²

Datasheet

Homing

Homing can be carried out in two ways:

- against the fixed stop
- Using a reference switch

The following values must be observed:

Size	45	60	80
Impact energy in end positions	0.13 mJ	0.25 mJ	0.75 mJ
Note on the impact energy in the end positions	At maximum homing speed of 0.01 m/s		

Materials

Material drive cover	Painted die cast aluminium
Material slide	Die-cast aluminium
Material cover tape	Stainless steel strip
Material toothed belt	Polychloroprene with glass fibre
Material guide slide	Tempered steel, Steel
Material profile	Anodised wrought aluminium alloy
Material end cap	Painted die cast aluminium
Note on materials	RoHS-compliant
Suitability for the production of Li-ion batteries	Metals with more than 1% copper, zinc or nickel by mass are excluded from use. Exceptions are nickel in steel, chemically nickel-plated surfaces, printed circuit boards, cables, electrical plug connectors and coils

Load values

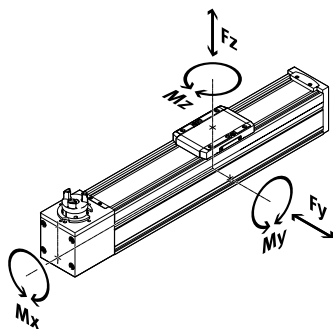

The indicated forces and torque refer to the centre of the guide. The point of application is the intersection of the centre of the guide and the centre of the length of the slide. They must not be exceeded in dynamic operation. Special attention must be paid to the deceleration process.

Permissible forces and torques on the overall axis (strength limits)

Size	45	60	80
Max. force F_y total axis	300 N	600 N	900 N
Max. force F_z total axis	600 N	1,800 N	2,700 N
Max. moment M_x total axis	5.5 Nm	29.1 Nm	59.8 Nm
Max. moment M_y total axis	4.7 Nm	31.8 Nm	56.2 Nm
Max. moment M_z total axis	4.7 Nm	31.8 Nm	56.2 Nm

Permissible forces and torques for the guide calculation with reference service life

Size	45	60	80
Reference service life	5,000 km		
Max. force F_y	880 N	3,641 N	5,543 N
Max. force F_z	880 N	3,641 N	5,543 N
Max. moment M_x	5.5 Nm	29.1 Nm	59.8 Nm
Max. moment M_y	4.7 Nm	31.8 Nm	56.2 Nm
Max. moment M_z	4.7 Nm	31.8 Nm	56.2 Nm

Datasheet

Distance x from the slide surface to the centre of the guide

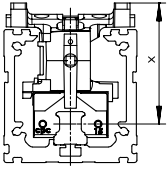

Distance x:

Size 45/60/80

Dimension x: 42.8 mm / 54.6 mm / 72.5 mm

Calculating the load comparison factor

$$f_v = \frac{|F_{y1}|}{F_{y2}} + \frac{|F_{z1}|}{F_{z2}} + \frac{|M_{x1}|}{M_{x2}} + \frac{|M_{y1}|}{M_{y2}} + \frac{|M_{z1}|}{M_{z2}} \leq 1$$

If the axis is subjected to several of the indicated forces and torques at the same time, the following equation must be satisfied in addition to the indicated maximum loads.

For a guide system to have a service life of 5000 km, the load comparison factor must have a value of $f_v < 1$, based on the maximum permissible forces and torques for a service life of 5000 km. This formula can be used to calculate a guide value. The engineering software “Electric Motion Sizing” is available for more precise calculations.

F1 / M1 = dynamic value

F2 / M2 = maximum value

Calculating the service life of the guide

The service life of the guide depends on the load. To provide a rough indication of the service life of the guide, the graph below plots the load comparison factor f_v against the service life.

These values are only theoretical. You must consult your local Festo contact for a load comparison factor f_v greater than 1.

Load comparison factor f_v as a function of service life l

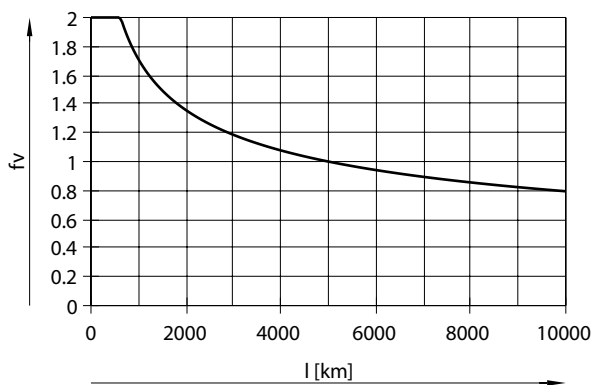

Example:

A user wants to move a X kg load. The calculation gives a value of 1.5 for the load comparison factor f_v . According to the graph, the guide would have a service life of approx. 1500 km. Reducing the acceleration reduces the M_y and M_z values. A load comparison factor f_v of 1 now results in a service life of 5000 km.

Datasheet

Permissible forces and torques at a theoretical service life of 100 km (pure guide load)

The characteristic load values of the bearing guides are standardised to ISO and JIS using dynamic and static forces and torques. These forces and torques are based on an expected service life of the guide system of 100 km to ISO or 50 km to JIS. As the characteristic load values are dependent on the service life, the maximum permissible forces and torques for a 5000 km service life cannot be compared with the dynamic forces and torques of roller guides to ISO/JIS.

To make it easier to compare the guide capacity of linear axes ELGC with bearing guides, the table below lists the theoretically permissible forces and torques for a calculated service life of 100 km. This corresponds to the dynamic forces and moments to ISO. These 100 km values have been calculated mathematically and are only to be used for comparing with dynamic forces and torques to ISO. The drives must not be loaded with these characteristic values as this could damage the axes.

Size	45	60	80
Fy at theoretical life value of 100 km (only guide consideration)	3,240 N	13,400 N	20,400 N
Fz at theoretical life value of 100 km (only guide consideration)	3,240 N	13,400 N	20,400 N
Mx at theoretical life value of 100 km (only guide consideration)	20 Nm	107 Nm	220 Nm
My at theoretical life value of 100 km (only guide consideration)	17 Nm	117 Nm	207 Nm
Mz at theoretical life value of 100 km (only guide consideration)	17 Nm	117 Nm	207 Nm

Feed force F as a function of input torque M

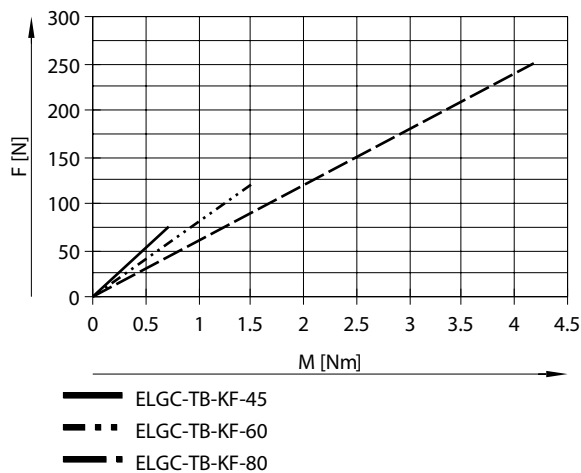

Max. permissible support spacing L (without profile mounting) as a function of force

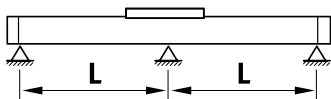

The axis may need to be supported in order to limit deflection in the case of long strokes.

The following graphs can be used to determine the maximum permissible support spacing l as a function of force F acting on the axis. The deflection is $f = 0.5$ mm.

Datasheet

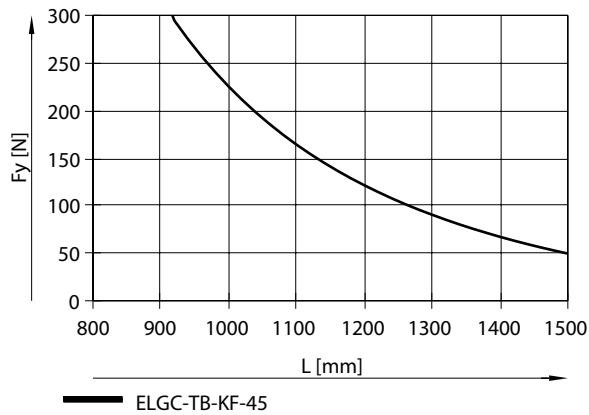
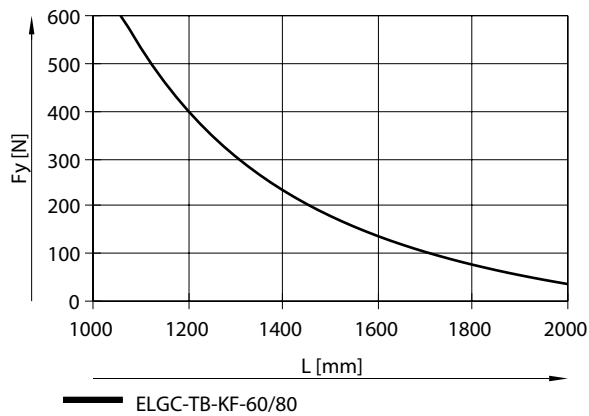
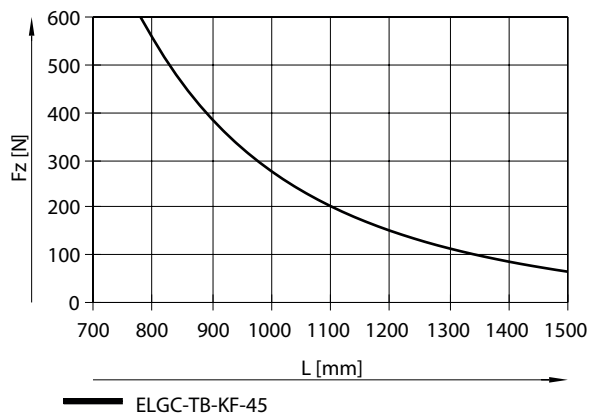
Max. permissible support spacing L (without profile mounting) as a function of force F_y for size 45Max. permissible support spacing L (without profile mounting) as a function of force F_y for size 60/80Max. permissible support spacing L (without profile mounting) as a function of force F_z for size 45

Datasheet

Max. permissible support spacing L (without profile mounting) as a function of force Fz for sizes 60/80

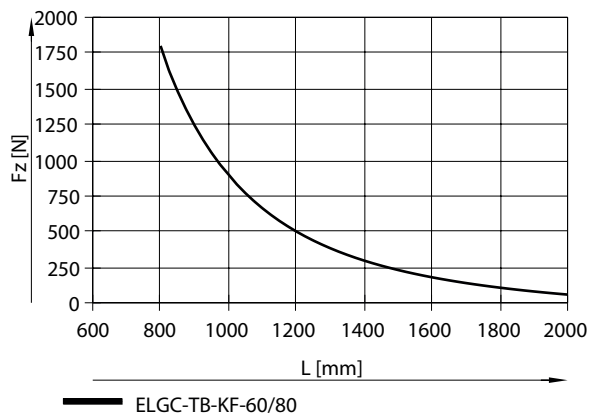

2nd moment of area

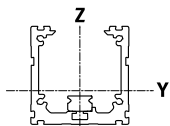

Size	45	60	80
2nd moment of area Iy	140,000 mm ⁴	441,000 mm ⁴	1,370,000 mm ⁴
2nd moment of area Iz	170,000 mm ⁴	542,000 mm ⁴	1,660,000 mm ⁴

Recommended deflection limits

Adherence to the following deflection limits is recommended so as not to impair the functionality of the axes. Greater deformation can result in increased friction, more wear and reduced service life.

Dynamic deflection (moving load)	0.05% of the axis length, max. 0.5 mm
Static deflection (load in standstill)	0.1% of the axis length

Combinations between axis ELGC, ELGS, mini slide EGSC-BS, EGSS-BS, electric cylinder EPCC, EPCS and guide axis ELFC

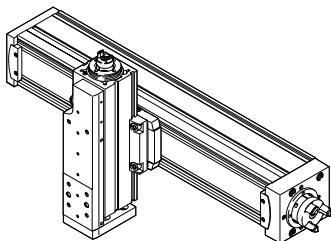

Mounting options with profile mounting EAHF-L2-...-P-D

- Mounting option: base axis with one-size-down assembly axis

1. Base axis:
Product: ELGC, ELGS, ELFC
Size 32, 45, 60, 80
2. Assembly axis:
Product: ELGC, ELGS, EGSC, EGSS, EPCC, EPCS, ELFC
Size 25, 32, 45, 60

Datasheet

Combinations between axis ELGC, ELGS, mini slide EGSC-BS, EGSS-BS, electric cylinder EPCC, EPCS and guide axis ELFC

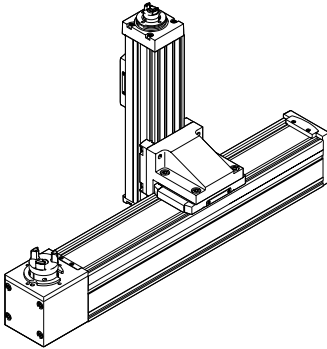

Mounting options with angle kit EHAA-D-L2-...-AP

- Mounting option: base axis with one-size-down assembly axis

1. Base axis:

Product: ELGC, ELGS, ELFC

Size 32, 45, 60, 80

2. Assembly axis:

Product: ELGC, ELGS, EGSC, EGSS, EPCC, EPCS, ELFC

Size 25, 32, 45, 60

Combinations between axis ELGC, ELGS, mini slide EGSC-BS, EGSS-BS, electric cylinder EPCC, EPCS and guide axis ELFC

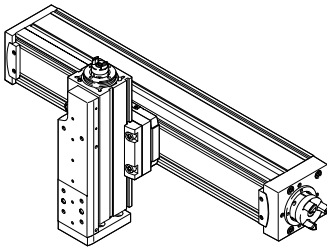

Mounting options with adapter kit EHAA-D-L2

- Mounting option: base axis with same size assembly axis
- Mounting option: base axis with height compensation for one-size-down assembly axis
- When motors are mounted using parallel kits, this may lead to interfering contours. In this case, the adapter plate is required for height compensation

1. Base axis:

Product: ELGC, ELGS, ELFC

Size 32, 45, 60, 80

2. Assembly axis:

Product: ELGC, ELGS, EGSC, EGSS, EPCC, EPCS, ELFC

Size 25, 32, 45, 60, 80

Combinations between mini slides EGSC-BS, EGSS-BS

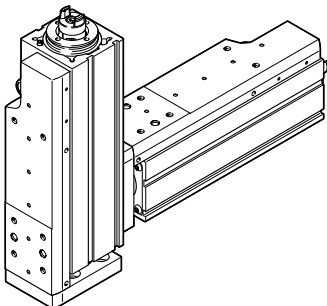

Mounting options with direct mounting

- Mounting option: base axis with same size assembly axis

1. Base axis:

Product: EGSC, EGSS

Size 25, 32, 45, 60

2. Assembly axis:

Product: EGSC, EGSS

Size 25, 32, 45, 60

Dimensions

Dimensions – Toothed belt axes ELGC-TB-KF

Download CAD data → www.festo.com

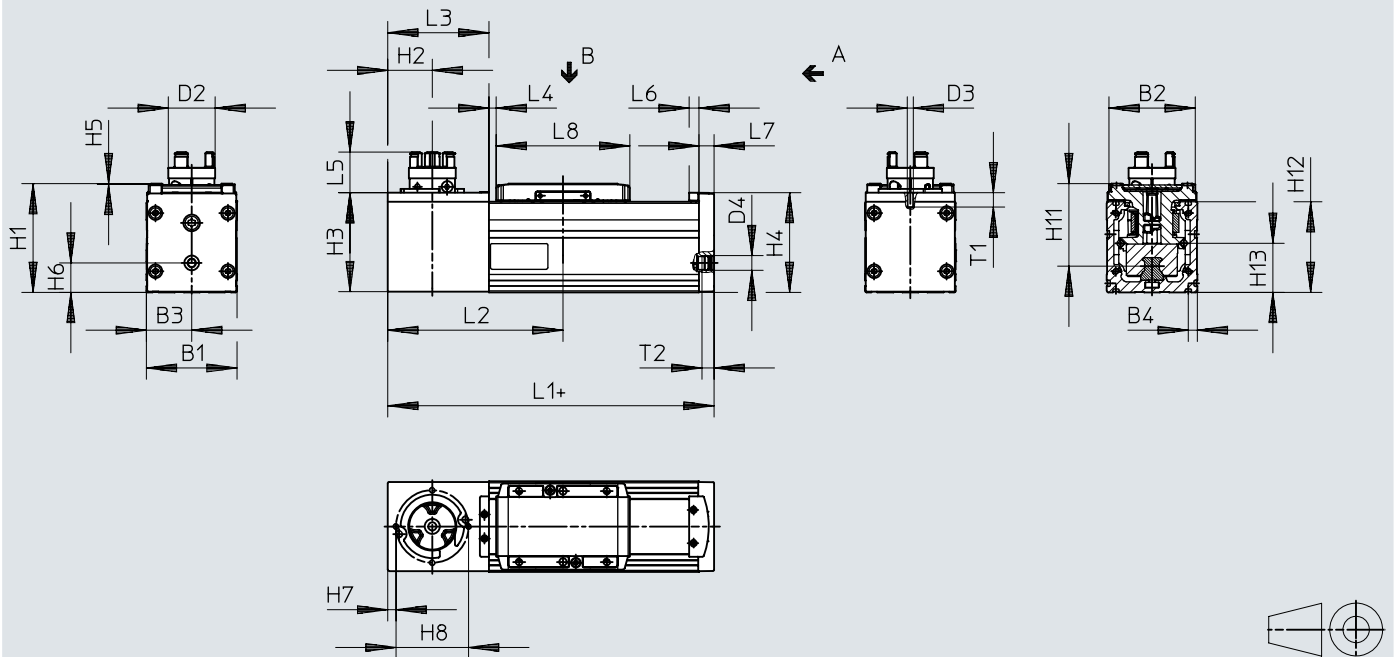

- [1] Sealing air connection (D4)
- [2] + = plus stroke length
- [3] L4 = End position zero stroke

	B1	B2	B3	B4	D2 ¹⁾ ∅	D3	D4	H1	H2
ELGC-TB-KF-45	45	42,6	22,5	6,1	16,3	–	G1/8	54	22
ELGC-TB-KF-60	60	57,1	30	6,1	31,4	M4	G1/8	72	29,5
ELGC-TB-KF-80	80	77,1	40	6,1	31,4	M6	G1/8	96	39,5

	H3	H4	H5	H6	H7	H8	H11	H12	H13
ELGC-TB-KF-45	49	49,6	0,5	12,5	–	–	42,8	45	18,5
ELGC-TB-KF-60	65,5	66,1	0,5	19,5	5,5	48	54,6	60	32,5
ELGC-TB-KF-80	85,5	88,1	0,5	20	7	65	72,5	80	41,5

	L1	L2 min.	L3	L4 ²⁾ min.	L5	L6	L7	L8	T1	T2
ELGC-TB-KF-45	165	90	52	4,25	19,9	6,5	7	67,5	–	8
ELGC-TB-KF-60	216	116	67	4,75	26,9	6,5	10	88,5	9,5	8
ELGC-TB-KF-80	260	145	87	5	25,9	6,5	12	106	12,5	8

- 1) Coupling diameter or interference circuit diameter clamping screw
- 2) Includes a stroke reserve of approx. 3 mm

Dimensions

Dimensions – Toothed belt axes ELGC-TB-KF (profile)

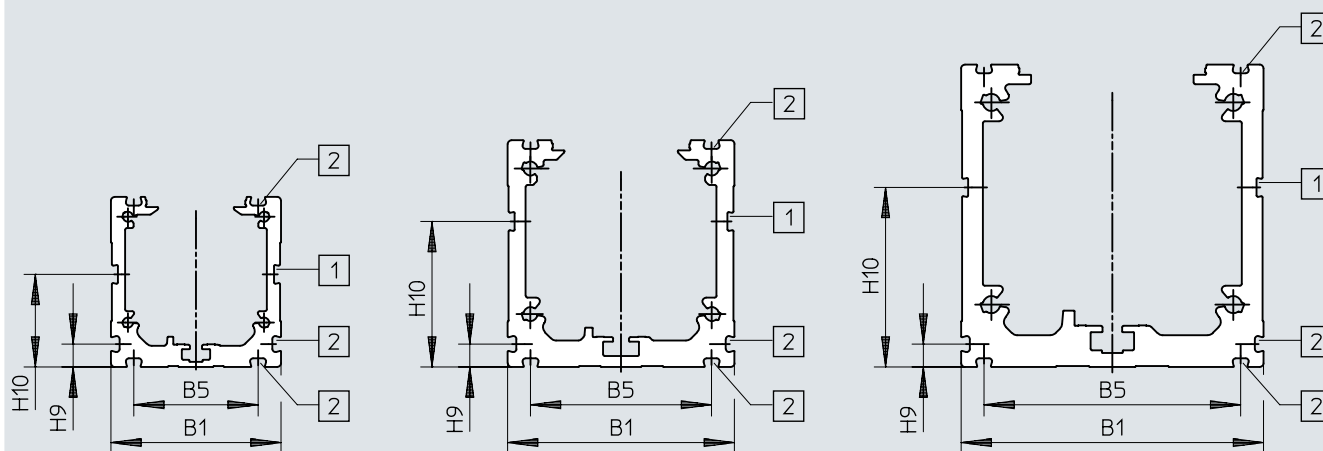
Download CAD data → www.festo.com

[1] = Slot for sensor bracket

[2] = Mounting slot

	B1	B5	H9	H10
ELGC-TB-KF-45	45	32,9	6,1	24,5
ELGC-TB-KF-60	60	47,9	6,1	38,5
ELGC-TB-KF-80	80	67,9	6,1	47,5

Dimensions

Dimensions – Toothed belt axes ELGC-TB-KF, size 45 (slide)

Download CAD data → www.festo.com

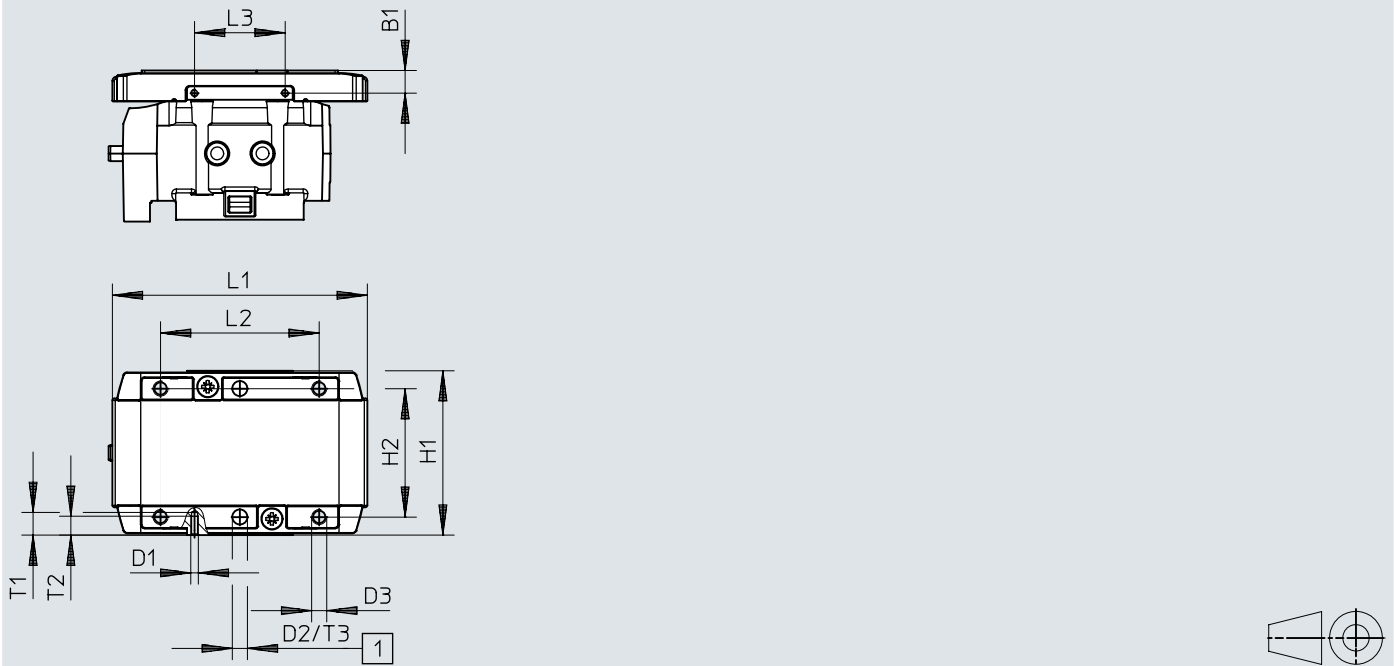

[1] Drilled hole for centring pin ZBS

	B1	D1	D2 ∅ H8	D3	H1	H2	L1	L2	L3	T1	T2	T3	T4 ¹⁾
ELGC-TB-KF-45	±0,1 6	M2	4	M4	±0,1 43,5	±0,1 34	67,5	±0,1 42	±0,1 24	6	5	±0,1 3,1	6 ... 7,5

1) Recommended screw-in depth

Dimensions

Dimensions – Toothed belt axes ELGC-TB-KF, size 60 (slide)

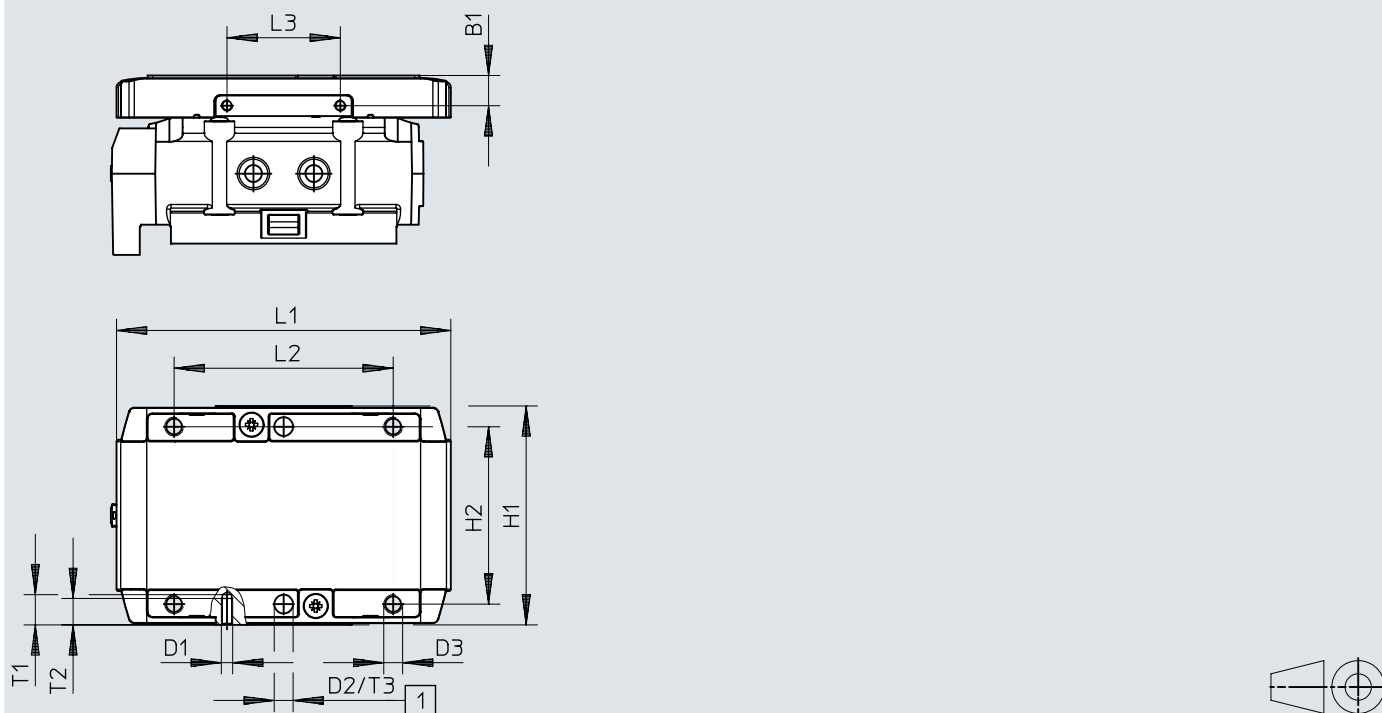
Download CAD data → www.festo.com

[1] Hole for centring sleeve ZBH

	B1	D1	D2 ∅ H8	D3	H1	H2	L1	L2	L3	T1	T2	T3	T4 ¹⁾
	±0,1				±0,1	±0,1		±0,1	±0,1			+0,1	
ELGC-TB-KF-60	8	M3	5	M5	58	47	88,5	58	30	9	7	1,3	8,5 ... 10

1) Recommended screw-in depth

Dimensions

Dimensions – Toothed belt axes ELGC-TB-KF, size 80 (slide)

Download CAD data → www.festo.com

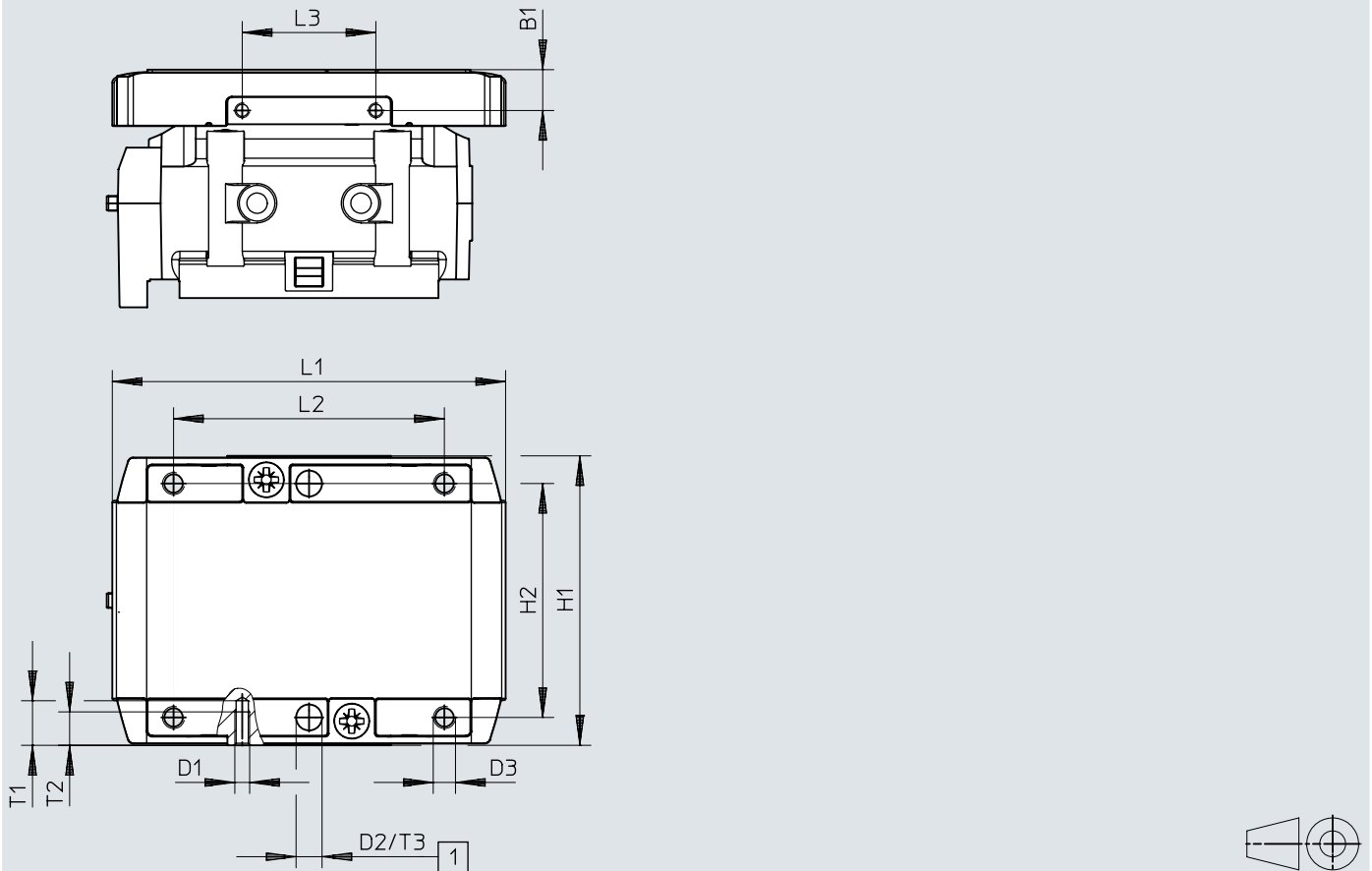

[1] Hole for centring sleeve ZBH

	B1	D1	D2 ∅ H8	D3	H1	H2	L1	L2	L3	T1	T2	T3	T4 ¹⁾
ELGC-TB-KF-80	±0,1	M4	7	M6	±0,1	±0,1	106	73	36	12	9	1,6	11 ... 14

1) Recommended screw-in depth

Dimensions

Dimensions – Profile mounting EAHF-L2-...-P-S

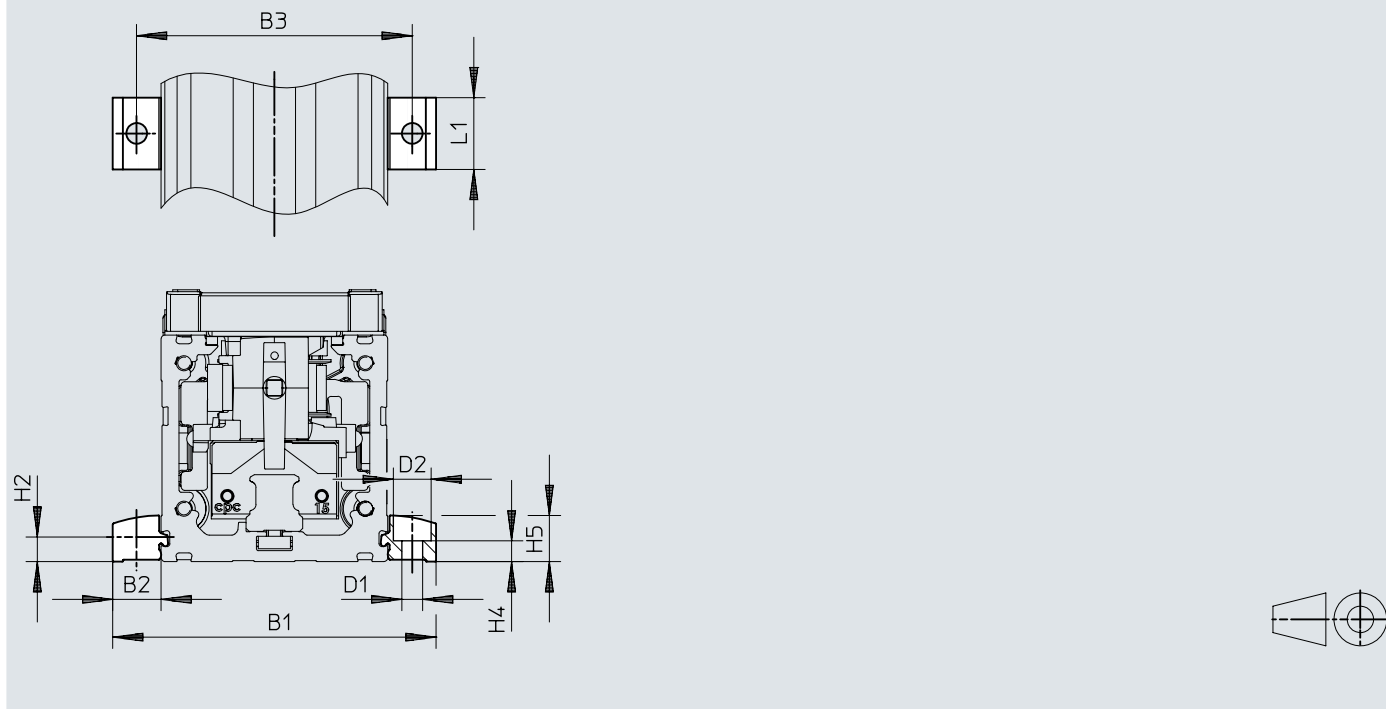
Download CAD data → www.festo.com

		B1	B2	B3	D1 ∅ H13	D2 ∅ H13	H2	H4 ±0,1	H5	L1
EAHF-L2-45-P-S	ELGC-TB-KF-45	70,6	12,8	58	5,5	10	6,1	5,5	12,2	19
EAHF-L2-45-P-S	ELGC-TB-KF-60	85,6	12,8	73	5,5	10	6,1	5,5	12,2	19
EAHF-L2-45-P-S	ELGC-TB-KF-80	105,6	12,8	93	5,5	10	6,1	5,5	12,2	19

Dimensions

Dimensions – Profile mounting EAHF-L2-...-P

Download CAD data → www.festo.com

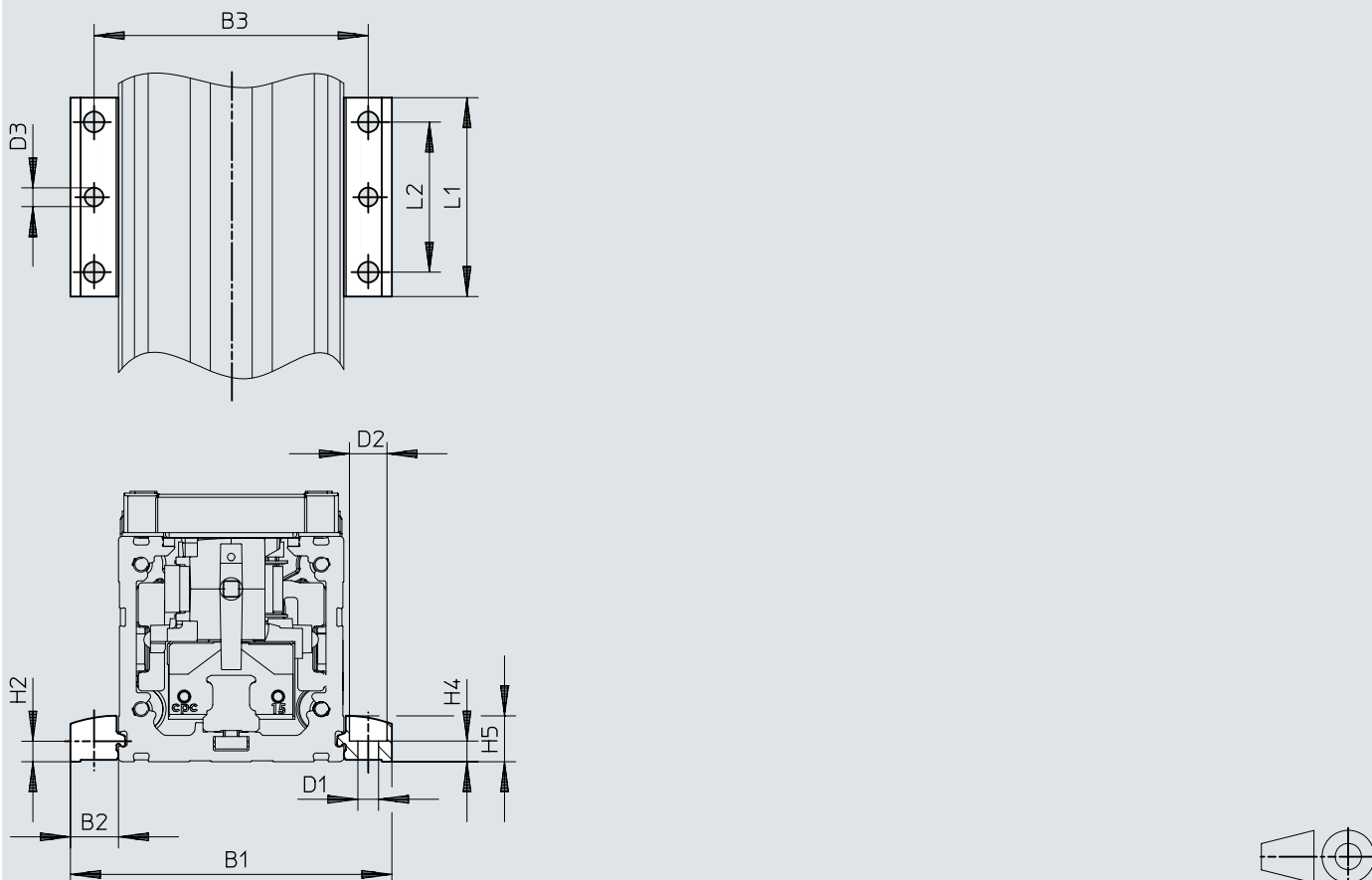

		B1	B2	B3	D1 ∅ H13	D2 ∅ H13	D3 ∅	H2	H4 ±0,1	H5	L1	L2
EAHF-L2-45-P	ELGC-TB-KF-45	70,6	12,8	58	5,5	10	5	6,1	5,5	12,2	53	40
EAHF-L2-45-P	ELGC-TB-KF-60	85,6	12,8	73	5,5	10	5	6,1	5,5	12,2	53	40
EAHF-L2-45-P	ELGC-TB-KF-80	105,6	12,8	93	5,5	10	5	6,1	5,5	12,2	53	40

Dimensions

Dimensions – Profile mounting EAHF-L2-...-P-D...

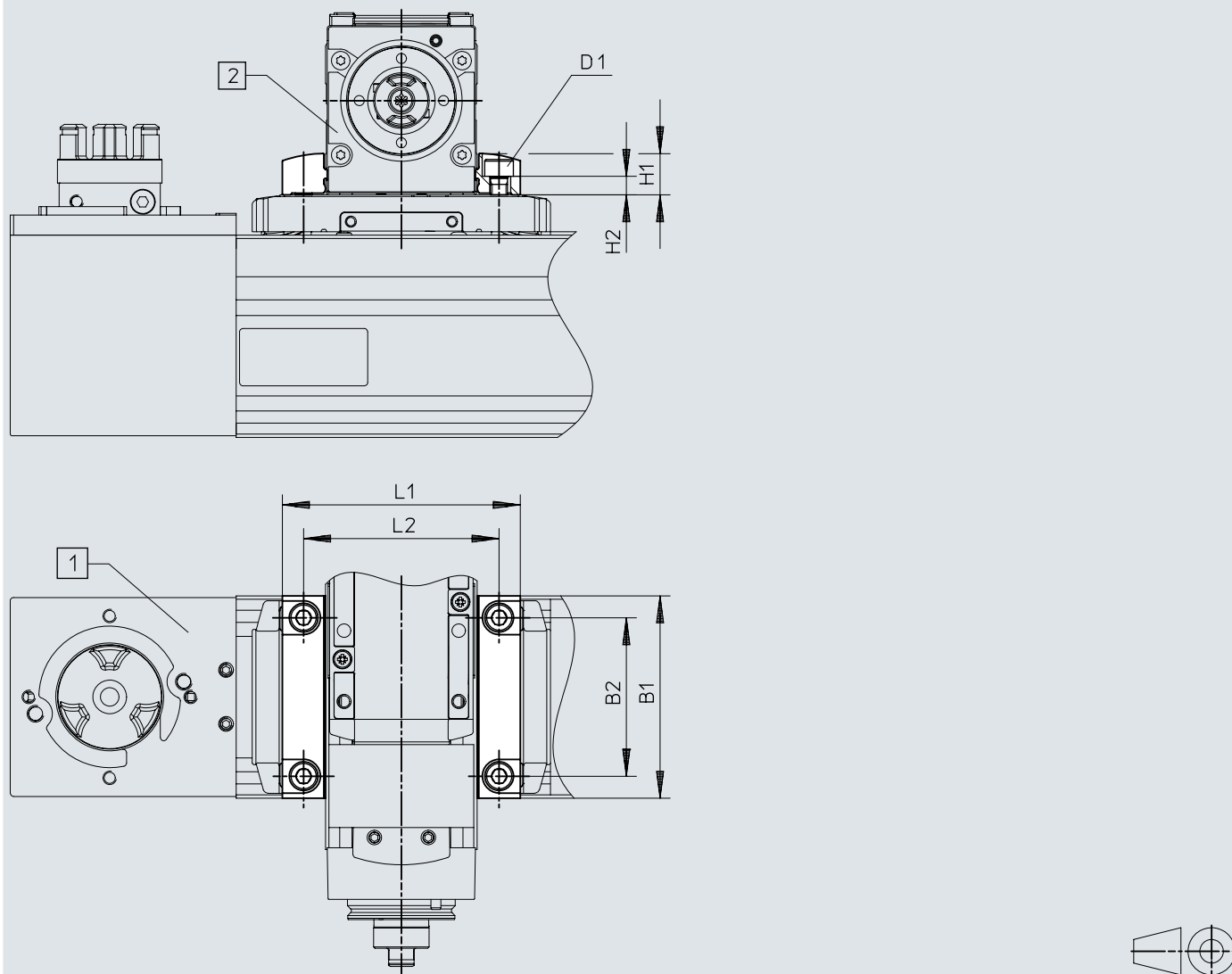
Download CAD data → www.festo.com

[1] Base axis ELGC/ELGS/ELFC

[2] Assembly axis ELGC/ELGS/ELFC/EGSC

	1)	B1	B2	H1	H2 ±0,1	L1	L2
EAHF-L2-25-P-D2	45/32	45	34	9	3,7	51,4	42
EAHF-L2-45-P-D3	60/45	60	47	12,2	5,5	70,6	58
EAHF-L2-45-P-D4	80/60	78	63	12,2	4,5	85,6	73

1) Base axis/assembly axis

Dimensions

Dimensions – Adapter kit EHAA-D-L2

Download CAD data → www.festo.com

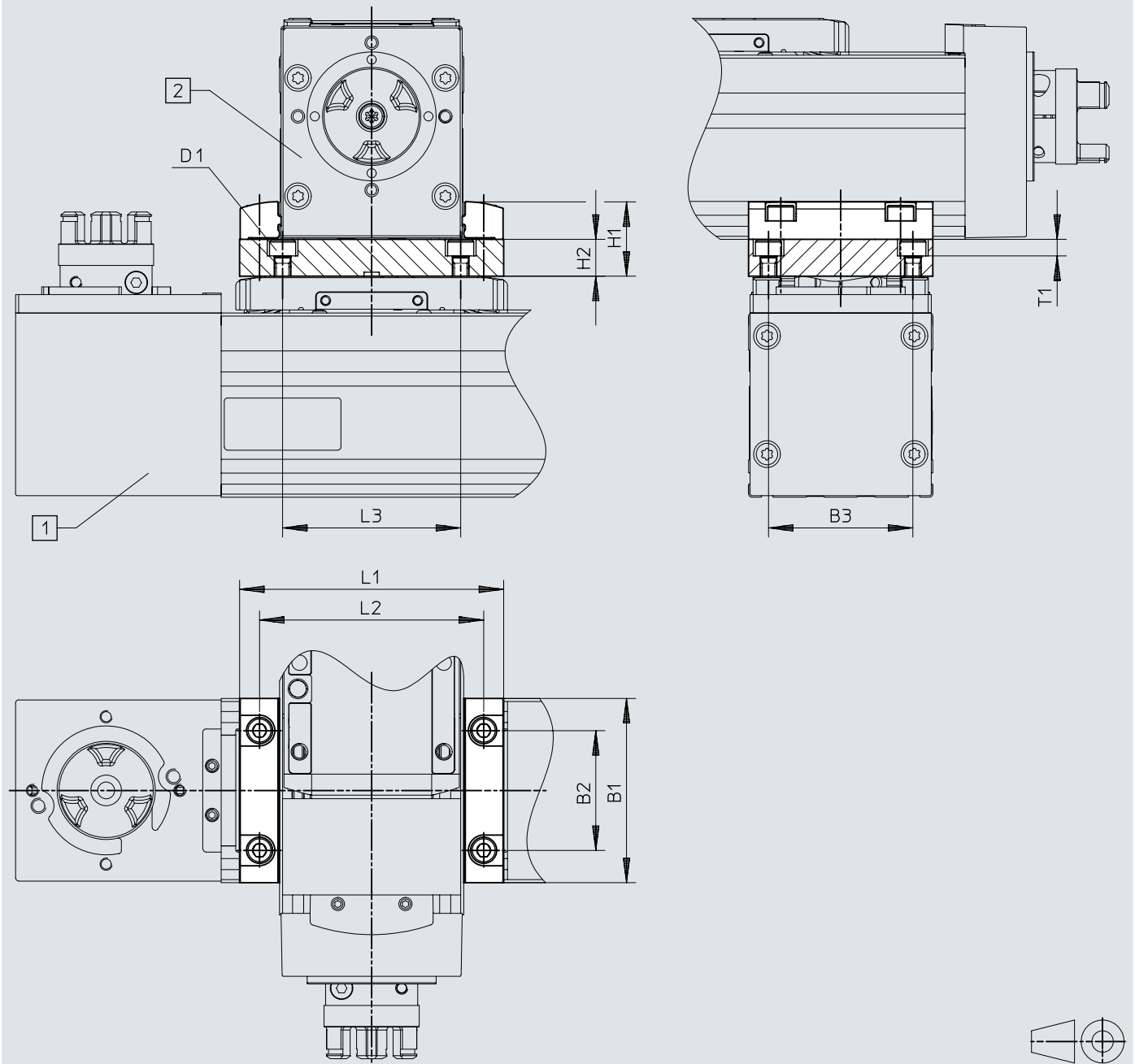

- [1] Base axis ELGC/ELGS/ELFC
- [2] Assembly axis ELGC/ELGS/ELFC/EGSC

Dimensions

	1)	B1	B3 ±0,05	D1	H1	H2	L1	L2	L3	T1
EHAA-D-L2-45-L2-45	45/32	45	34	M4	19	10	51,4	42	42	5,4
EHAA-D-L2-60-L2-60	60/45	60	47	M5	24,2	12	70,6	58	58	5,4
EHAA-D-L2-80-L2-80	80/60	78	63	M6	24,2	12	85,6	73	73	6,4

	1)	B1	B2	B3 ±0,05	D1	H1	H2	L1	L2	L3	T1
EHAA-D-L2-45-L2-45	45/45	45	32	34	M4	22,2	10	71	58	42	5,4
EHAA-D-L2-60-L2-60	60/60	60	39	47	M5	24,2	12	86	73	58	5,4
EHAA-D-L2-80-L2-80	80/80	78	63	63	M6	24,2	12	106	93	73	6,4

1) Base axis/assembly axis

Dimensions

Dimensions – Angle kit EHAA-D-L2-...-AP

Download CAD data → www.festo.com

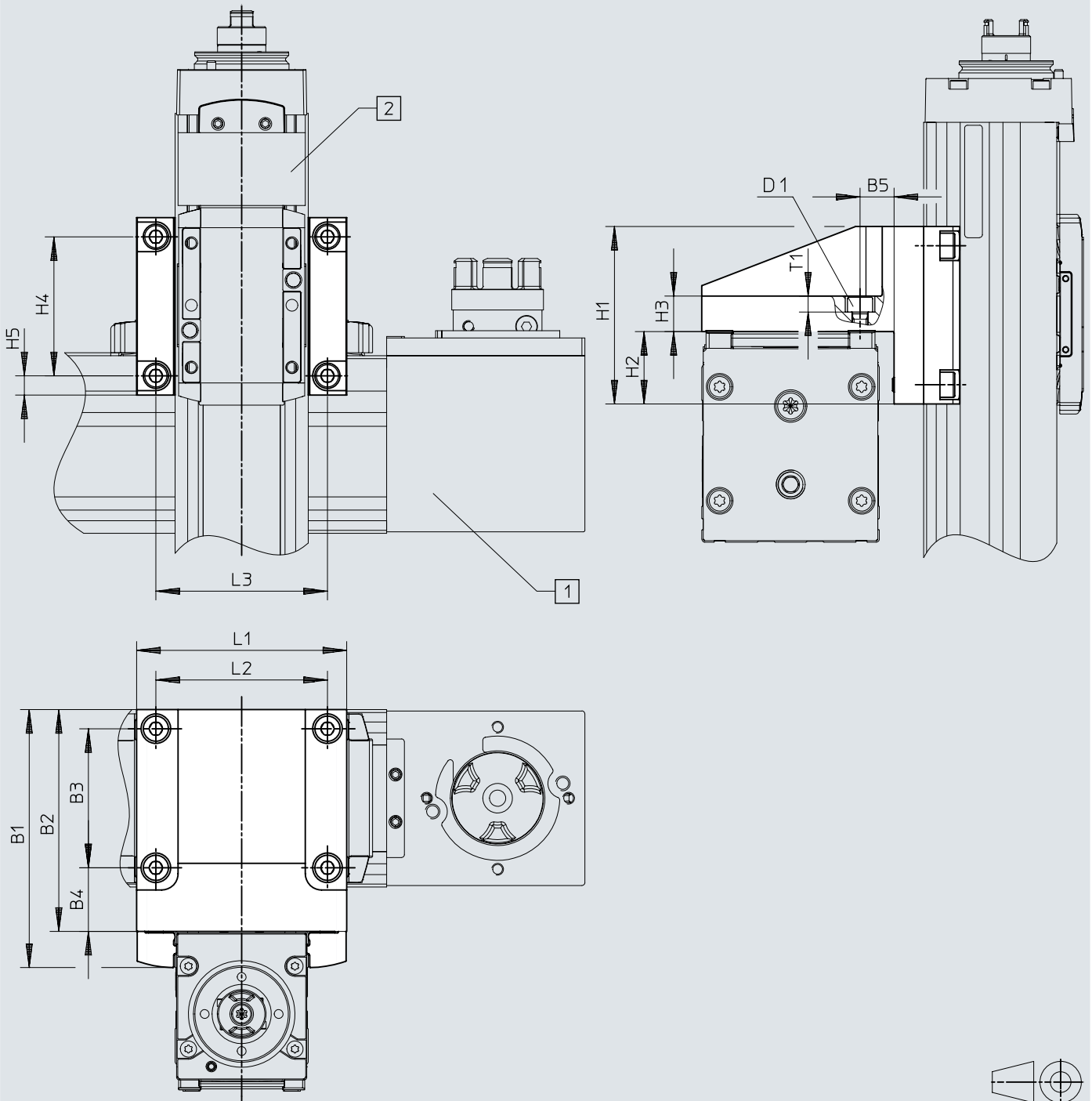

- [1] Base axis ELGC/ELGS/ELFC
- [2] Assembly axis ELGC/ELGS/ELFC/EGSC

Dimensions

	1)	B1	B2	B3	B4	B5	D1	H1	H2
EHAA-D-L2-45-L2-32-AP	45/32	69	60	34	20,5	11,5	M4	45	17,5
EHAA-D-L2-60-L2-45-AP	60/45	87,2	75	47	21,5	21,5	M5	60	24,5
EHAA-D-L2-80-L2-60-AP	80/60	107,2	95	63	23,5	23,5	M6	78	33,5

	1)	H3	H4	H5	L1	L2	L3	T1
EHAA-D-L2-45-L2-32-AP	45/32	10	34	5,5	52	42	42	5,4
EHAA-D-L2-60-L2-45-AP	60/45	12	47	6,5	71	58	58	5,4
EHAA-D-L2-80-L2-60-AP	80/60	12	63	7,5	86	73	73	6,4

1) Base axis/assembly axis

Dimensions

Dimensions – Switch lug EAPM-L2-SLS

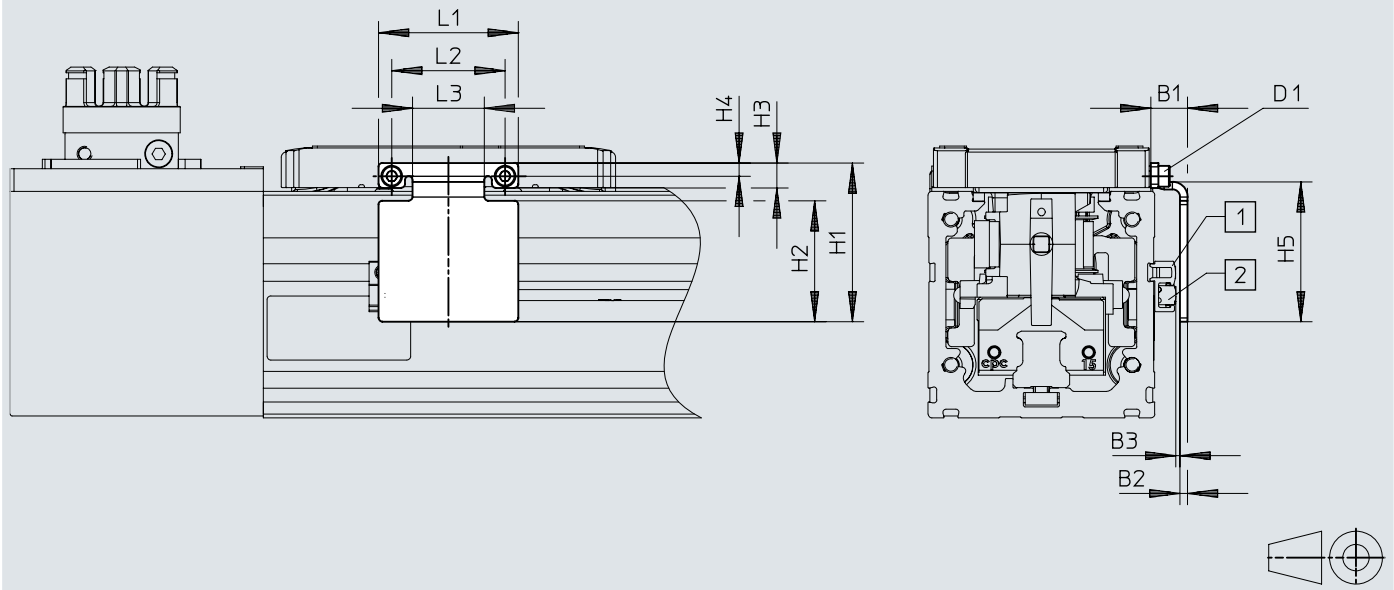
Download CAD data → www.festo.com

- [1] Sensor bracket
[2] Proximity switch

	B1	B2	B3	D1	H1 ±0,2	H2	H3	H4	H5 ±0,2	L1 ±0,2	L2 ±0,15	L3
EAPM-L2-45-SLS	9,4	2	1,2±0,31	M2	37	28	5,5	3,3	33	30	24	14
EAPM-L2-60-SLS	9,7	2	1,3±0,31	M3	42	32	6,6	3,5	37	37	30	19
EAPM-L2-80-SLS	9,5	2	1,1±0,32	M4	53,5	42	8,3	4,5	47	44,6	36	23,4

Dimensions

Dimensions – Sensor bracket EAPM-L2-SH

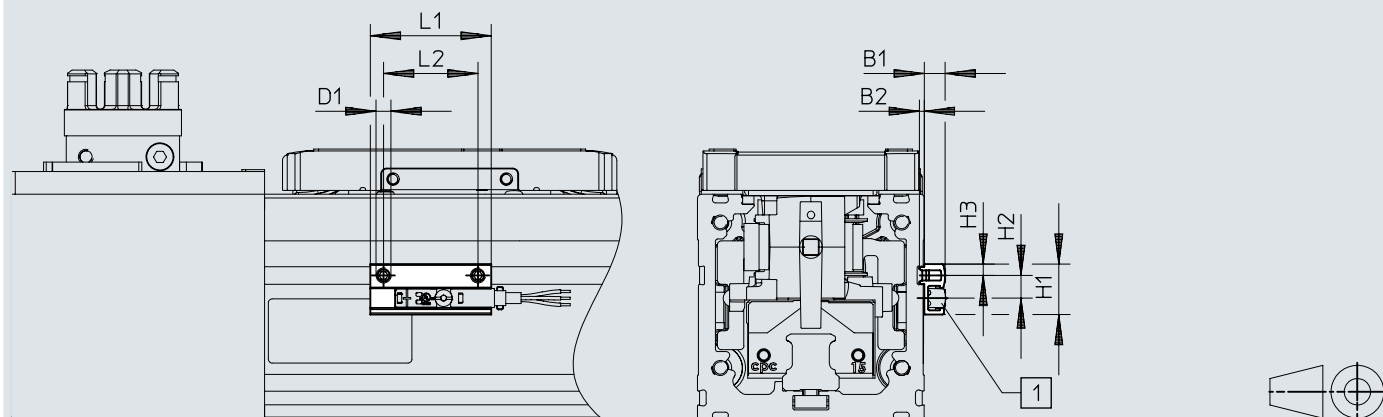
Download CAD data → www.festo.com

[1] Proximity switch

	B1	B2	D1	H1	H2	H3	L1	L2
EAPM-L2-SH	5,5	1,3	M4	13,4	6	3	32	25

Ordering data

with recirculating ball bearing guide				
	Size	Working stroke	Part no.	Type
	45	200 mm	8062768	ELGC-TB-KF-45-200
		300 mm	8062769	ELGC-TB-KF-45-300
		500 mm	8062770	ELGC-TB-KF-45-500
		600 mm	8062771	ELGC-TB-KF-45-600
		800 mm	8062772	ELGC-TB-KF-45-800
		1,000 mm	8062773	ELGC-TB-KF-45-1000
		1,200 mm	8062774	ELGC-TB-KF-45-1200
		1,500 mm	8062775	ELGC-TB-KF-45-1500
	60	200 mm	8062776	ELGC-TB-KF-60-200
		300 mm	8062777	ELGC-TB-KF-60-300
		500 mm	8062778	ELGC-TB-KF-60-500
		600 mm	8062779	ELGC-TB-KF-60-600
		800 mm	8062780	ELGC-TB-KF-60-800
		1,000 mm	8062781	ELGC-TB-KF-60-1000
		1,200 mm	8062782	ELGC-TB-KF-60-1200
		1,500 mm	8062783	ELGC-TB-KF-60-1500
		1,800 mm	8062784	ELGC-TB-KF-60-1800
		2,000 mm	8062785	ELGC-TB-KF-60-2000
	80	200 mm	8062786	ELGC-TB-KF-80-200
		300 mm	8062787	ELGC-TB-KF-80-300
		500 mm	8062788	ELGC-TB-KF-80-500
		600 mm	8062789	ELGC-TB-KF-80-600
		800 mm	8062790	ELGC-TB-KF-80-800
		1,000 mm	8062791	ELGC-TB-KF-80-1000
		1,200 mm	8062792	ELGC-TB-KF-80-1200
1,500 mm		8062793	ELGC-TB-KF-80-1500	
1,800 mm		8062794	ELGC-TB-KF-80-1800	
2,000 mm		8062795	ELGC-TB-KF-80-2000	

Peripherals

Peripherals overview

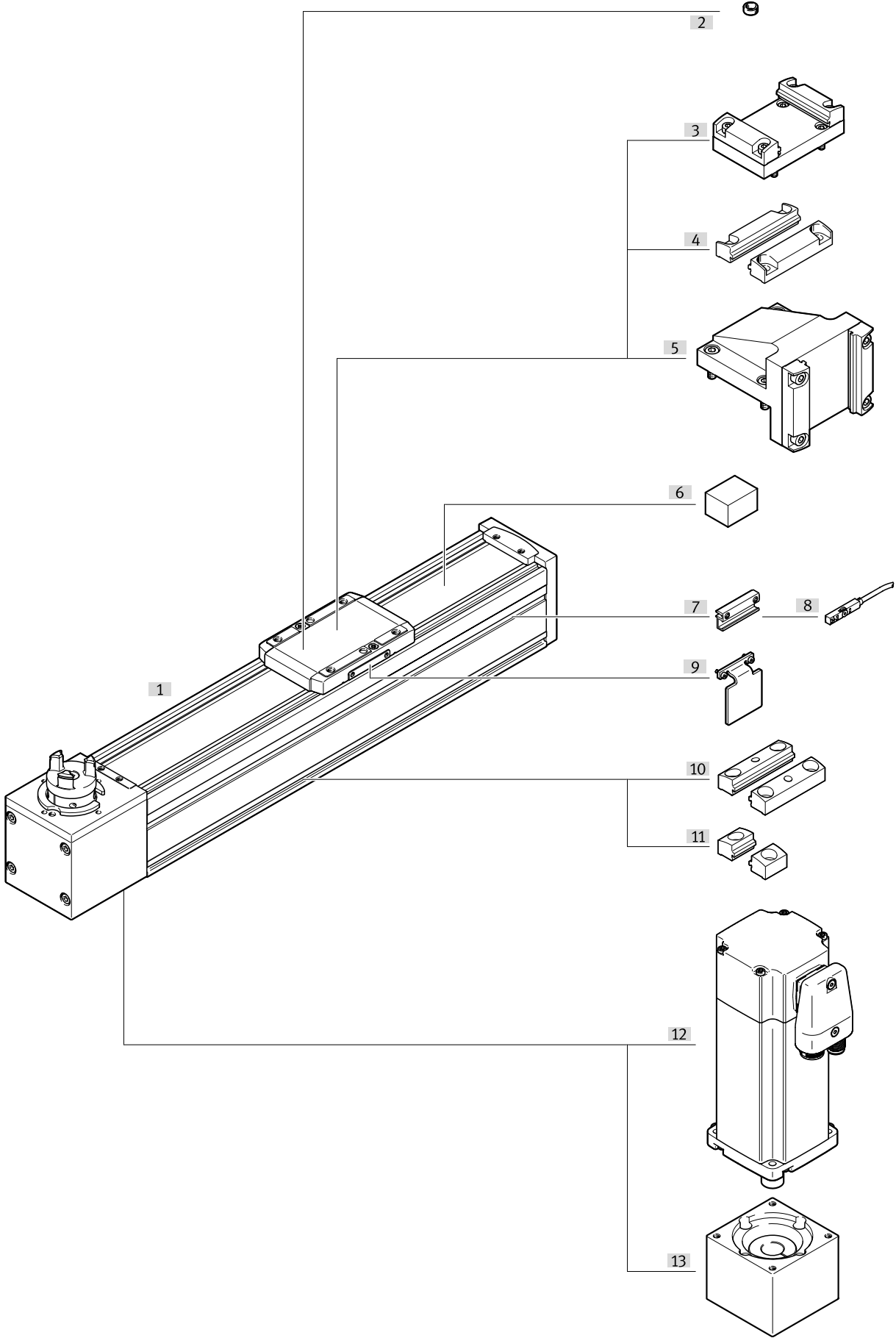

Peripherals

Accessories		→ Page/Internet
Type/order code	Description	
[1] Toothed belt axis ELGC-TB-KF	Electric drive	elgc-tb
[2] Centring sleeve ZBH	For centring loads and attachments on the slide	30
[2] Centring pin ZBS	For centring loads and attachments on the slide	30
[3] Adapter kit EHAA-D-L2	<ul style="list-style-type: none"> • For axis/axis mounting with adapter plate • Mounting option: base axis with the same size or one-size-down assembly axis • When motors are mounted using parallel kits, interfering contours may occur. In this case, the adapter plate is required for height compensation 	29
[4] Profile mounting EAHF-L2-...-P-D	<ul style="list-style-type: none"> • For axis/axis mounting without adapter plate • Mounting option: base axis with one-size-down assembly axis 	29
[5] Angle kit EHAA-D-L2-...-AP	For mounting one-size-down vertical axes (assembly axes) on base axes with mounting position “slide at top”	29
[6] Clamping element EADTS-L5	Tool for retensioning the cover strip	30
[7] Sensor bracket EAPM-L2-SH	For mounting the proximity switches on the axis. The proximity switches can only be mounted using the sensor bracket	30
[8] Proximity switch SIES-8M	Inductive proximity sensors, for T-slot	31
[8] Proximity switches SMT-8M	Magnetic proximity switches, for T-slot	31
[9] Switch lug EAPM-L2-...-SLS	For sensing the slide position in conjunction with inductive proximity switches SIES-8M	30
[10] Profile mounting EAHF-L2-...-P	For mounting the axis on the side of the profile. The profile mounting can be attached to the mounting surface using the drilled hole in the centre	29
[11] Profile mounting EAHF-L2-...-P-S	For mounting the axis on the side of the profile	29
[12] Motor EMME-AS	Motors and kits specially matched with the axis Detailed information: www.festo.com/catalogue/eamm Engineering tool: www.festo.com/x/electric-motion-sizing	emme-as
[12] Motor EMMT-AS	Motors and kits specially matched with the axis Detailed information: www.festo.com/catalogue/eamm Engineering tool: www.festo.com/x/electric-motion-sizing	emmt-as
[12] Motor EMMS-ST	Motors and kits specially matched with the axis Detailed information: www.festo.com/catalogue/eamm Engineering tool: www.festo.com/x/electric-motion-sizing	emms-st
[13] Axial kit EAMM-A	For axial motor mounting Detailed information: www.festo.com/catalogue/eamm	eamm-a

Accessories

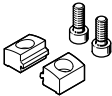
Profile mounting EAHF-L2-...-P-S						
	Description	Suitability for the production of Li-ion batteries	Material plate	Product weight	Part no.	Type
	For size 45, 60, 80	F1a	Anodised wrought aluminium alloy	6 g	5184133	EAHF-L2-45-P-S

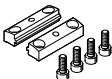
Profile mounting EAHF-L2-...-P						
	Description	Suitability for the production of Li-ion batteries	Material plate	Product weight	Part no.	Type
	For size 45, 60, 80	F1a	Anodised wrought aluminium alloy	35 g	4835728	EAHF-L2-45-P

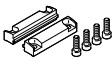
Profile mounting EAHF-L2-...-P-D...						
	Description ¹⁾	Suitability for the production of Li-ion batteries	Material plate	Product weight	Part no.	Type
	For size 45/32	F1a	Anodised wrought aluminium alloy	24 g	4759748	EAHF-L2-25-P-D2
	For size 60/45			56 g	4759739	EAHF-L2-45-P-D3
	For size 80/60			77 g	4759726	EAHF-L2-45-P-D4

1) Base axis/assembly axis

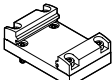
Adapter kit EHAA-D-L2						
	Description ¹⁾	Material adapter plate	Product weight	Part no.	Type	
	For size 45/32		136 g	8066714	EHAA-D-L2-45-L2-45	
	For size 60/45		205 g	8066715	EHAA-D-L2-60-L2-60	
	For size 80/60		315 g	8066716	EHAA-D-L2-80-L2-80	

1) Base axis/assembly axis

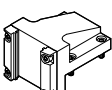
Angle kit EHAA-D-L2-...-AP						
	Description ¹⁾	Material adapter plate	Product weight	Part no.	Type	
	For size 45/32		222 g	8066718	EHAA-D-L2-45-L2-32-AP	
	For size 60/45		433 g	8066719	EHAA-D-L2-60-L2-45-AP	
	For size 80/60		768 g	8066720	EHAA-D-L2-80-L2-60-AP	

1) Base axis/assembly axis

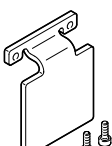
Switch lug EAPM-L2-SLS						
	Description	Suitability for the production of Li-ion batteries	Material switch lug	Product weight	Part no.	Type
	For size 45	F1a		18 g	8067260	EAPM-L2-45-SLS

Accessories

Switch lug EAPM-L2-SLS

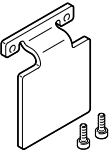
	Description	Suitability for the production of Li-ion batteries	Material switch lug	Product weight	Part no.	Type
	For size 60	F1a		27 g	8067261	EAPM-L2-60-SLS
	For size 80			42 g	8067262	EAPM-L2-80-SLS

Sensor bracket EAPM-L2-SH

	Description	Suitability for the production of Li-ion batteries	Product weight	Material sensor bracket	Part no.	Type
	For size 45, 60, 80	F1a	4 g	Anodised wrought aluminium alloy	★ 4759852	EAPM-L2-SH

Centring pin ZBS-4

	Description	Material sleeve	Size of pack	Product weight	Part no.	Type
	For size 45	High-alloy stainless steel	10	0.5 g	562959	ZBS-4

Centring sleeve ZBH-5

	Description	Material sleeve	Size of pack	Product weight	Part no.	Type
	For size 60	Steel	10	1 g	8146543	ZBH-5-B

Centring sleeve ZBH-7

	Description	Material sleeve	Size of pack	Product weight	Part no.	Type
	For size 80	Steel	10	1 g	8146544	ZBH-7-B

Clamping element EADT

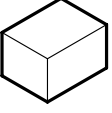
	Description	Material clamping element	Product weight	Part no.	Type
	For size 45, Tool for retensioning the cover strip	NBR	12 g	8065818	EADT-S-L5-32
	For size 60, 80, Tool for retensioning the cover strip		50 g	8058451	EADT-S-L5-70

Push-in fitting QSM

	Description	Material housing	Size of pack	Product weight	Part no.	Type
	For size 45, 60, 80, For sealing air connection	Brass, nickel-plated	10	8.9 g	★ 186266	QSM-G1/8-4-I
				9.5 g	★ 186267	QSM-G1/8-6-I

Accessories

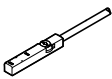
Proximity switch SIES for T-slot, inductive						Further information → sies-8m
	Switching output	Switching element function	Electrical connection 1, connector system	Cable length	Part no.	Type
	NPN	N/C contact	M8x1, A-coded, to EN 61076-2-104	0.3 m	★ 551402	SIES-8M-NO-24V-K-0,3-M8D
			Open end	7.5 m	★ 551401	SIES-8M-NO-24V-K-7,5-OE
		N/O contact	M8x1, A-coded, to EN 61076-2-104	0.3 m	551397	SIES-8M-NS-24V-K-0,3-M8D
			Open end	7.5 m	551396	SIES-8M-NS-24V-K-7,5-OE
	PNP	N/C contact	M8x1, A-coded, to EN 61076-2-104	0.3 m	★ 551392	SIES-8M-PO-24V-K-0,3-M8D
			Open end	7.5 m	★ 551391	SIES-8M-PO-24V-K-7,5-OE
		N/O contact	M8x1, A-coded, to EN 61076-2-104	0.3 m	551387	SIES-8M-PS-24V-K-0,3-M8D
			Open end	7.5 m	551386	SIES-8M-PS-24V-K-7,5-OE

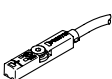
Proximity switch SMT for T-slot, magneto-resistive						Further information → smt-8m
	Type of mounting	Switching output	Electrical connection	Cable length	Part no.	Type
	Screw-clamped, Insertable in the slot from above	3-wire PNP N/C contact	Open end	7.5 m	★ 574340	SMT-8M-A-PO-24V-E-7,5-OE
				2.5 m	★ 574335	SMT-8M-A-PS-24V-E-2,5-OE
		3-wire PNP N/O contact	Plug M8, A-coded	0.3 m	★ 574334	SMT-8M-A-PS-24V-E-0,3-M8D

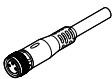
Connecting cables NEBU, straight						
	Electrical connection 1, connector system	Electrical connection 2, connector system	Electrical connection 2, number of connections/cores	Cable length	Part no.	Type
	M8x1, A-coded, to EN 61076-2-104	Open end	3	2.5 m	541333	NEBU-M8G3-K-2.5-LE3
				5 m	541334	NEBU-M8G3-K-5-LE3

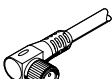
Connecting cables NEBU, angled						
	Electrical connection 1, connector system	Electrical connection 2, connector system	Electrical connection 2, number of connections/cores	Cable length	Part no.	Type
	M8x1, A-coded, to EN 61076-2-104	Open end	3	2.5 m	541338	NEBU-M8W3-K-2.5-LE3
				5 m	541341	NEBU-M8W3-K-5-LE3