

Linear gantries

FESTO

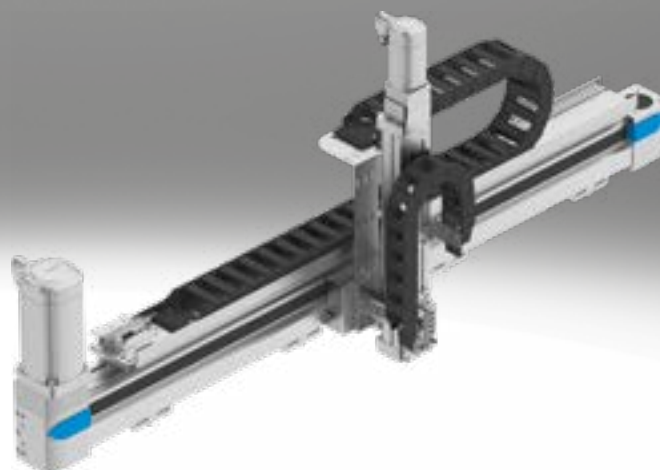

Key features

At a glance

A linear gantry (YXCL) is an assembly of several axis modules (EHM.../DHMZ) to produce a movement in 2D space.

The linear gantry facilitates movement in 2D space.

Depending on the requirements, the gantry is either composed of several axis modules (YXCL) or using the linear gantry EXCT (YXML). All of these are tried-and-tested components from Festo.

- Very demanding requirements for precision and/or very heavy workpieces combined with long strokes (YXCR)
- Cost-effective handling unit in a compact format for small parts handling and simple tasks (YXCR-B)
- Frequently used in feeding or loading applications
- Use of tried-and-tested drives/axes from Festo

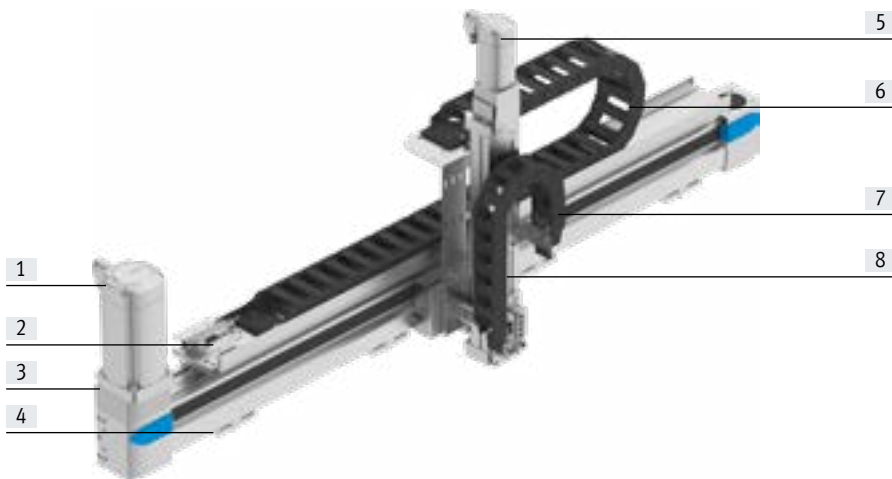

- [1] Servo motor for the Y-module
- [2] Multi-pin plug distributor which transfers all the electrical signals such as for end-position sensing
- [3] Y-axis
- [4] Profile mounting/adjusting kit
- [5] Servo motor for the Z-module
- [6] Energy chain for the Y-module
- [7] Energy chain for the Z-module
- [8] Z-axis

Description of the modules

Y-module

Design:

The Y-module EHYM comprises a linear axis which is powered by a servo or stepper motor.

Adapters are mounted on the slides of the Y-axis to connect the Z-module.

The following components are located on the side of the motor:

- Energy chain (optional)
- Multi-pin plug distributor for proximity switch (if a sensor package has been selected)

Sample image:

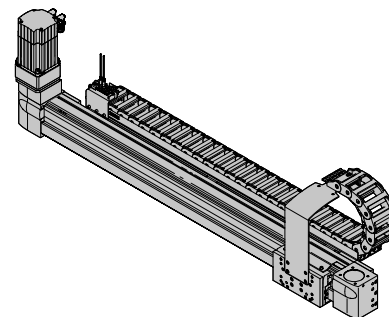

Z-module

Design:

The Z-module EHMZ comprises an electric drive, the DHMZ comprises a pneumatic drive. Based on the configuration, an energy chain is optionally installed as a cable guide depending on the axis type and stroke. The Z-module can be selected using the configurator, depending on the application.

Sample image:

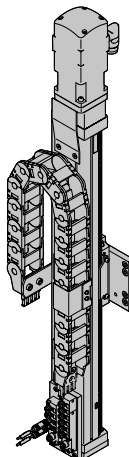

Key features

Description of the modules

YZ-module (EXCT)

Design:

Two fixed servo motors drive a toothed belt arranged in a T-shape.

The toothed belt moves the slide of the Y-axis and the interface located on the Z-axis in a two-dimensional space.

A controller calculates the position of the interface. The controlled interaction of the motors results in the movement of the interface.

Attachment components enable additional processes to be carried out.

Sample image:

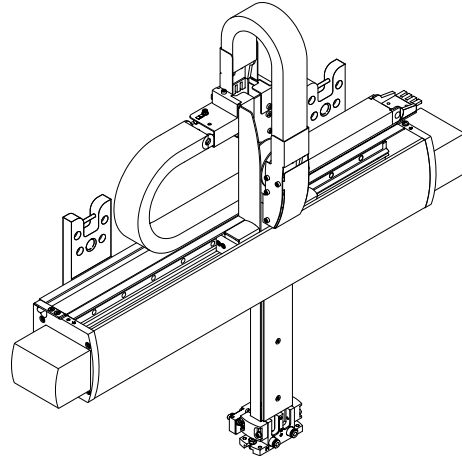

Dispatch options

Fully assembled:

The linear gantry is fully assembled. All cables and tubing are installed and connected.

Partially assembled:

The linear gantry is delivered partially assembled. This means that both axis modules (Y-/Z-axis) are assembled, each with the optional motors. The partially assembled system must be completed by the customer. Help can be found in the assembly instructions provided.

Optional accessories (→ page 10) are enclosed.

Note flatness → table below.

System overview¹⁾

| Size | YXCL-1 | YXCL-2 | YXCL-3 | YXCL-4 | YXML-1 | YXML-2 | YXML-3 |
|---------------------|--|--------------------------|--------------------------|--------------------------|-------------------------|-------------------------|-------------------------|
| Max. working stroke | Y: 1900 mm Z: 50 mm | Y: 3000 mm Z: 1000 mm | Y: 3000 mm Z: 1200 mm | Y: 3000 mm Z: 1200 mm | Y: 1000 mm Z: 200 mm | Y: 1500 mm Z: 500 mm | Y: 2000 mm Z: 800 mm |
| Max. payload | Dependent on the selected dynamic response | | | | | | |
| Mounting position | Horizontal | | | | | | |

| Size | YXCL-1-B | YXCL-2-B |
|---------------------|--|-------------------------|
| Max. working stroke | Y: 800 mm Z: 150 mm | Y: 1200 mm Z: 200 mm |
| Max. payload | Dependent on the selected dynamic response | |
| Mounting position | Horizontal | |

1) Drive package depends on the configuration selected.

Key features

Configurator: Handling Guide Online (HGO)

Selecting a handling system

Planning complex handling systems takes a lot of time. You can use the configurator "Handling Guide Online" (HGO) to design a customised handling system for your application in just a few steps.

You can choose from the following systems:

- Single-axis system
- 2D linear gantry
- 2D planar surface gantry
- Three-dimensional gantry
- 3D cantilever system

Advantages:

- Automatic selection of all relevant components
- Automatic design and calculation of the workload
- Quote created automatically
- CAD model available immediately
- Configuration-specific parameters for servo drives available immediately
- Complete Eplan project can be ordered according to the individual configuration
- Fully automated processing
- You can order fully or partially assembled systems through the Online Shop
- Lots of possible options

Selecting the handling solution
Select your handling system

- Single-axis system**
Single-axis movement.
Single-axis module as a complete system.
Easy to connect to your own front unit.
[] Air-tation
- 2D linear gantry**
Movements in 2D in the vertical working space.
Linear gantries as complete systems.
Electric and pneumatic axes can be combined.
[] Air-tation
- 2D gantry**
Movements in 2D in the horizontal working space.
Planar surface gantries as complete systems.
Combining electric axes.
Easy to connect to your own Z unit.
[] Air-tation
- 3D gantry**
Movements in 3D.
Three-dimensional gantries as complete systems.
Electric and pneumatic axes can be combined.
[] Air-tation
- 3D cantilever system**
Movements in 3D.
Cantilever system as complete system.
Electric and pneumatic axes can be combined.

Entering the application data

- Payload
- Drive system of the axis
- Distance from the centre of the load
- Working stroke
- Reference cycle

Axis definition and payload
Axis definition

Drive system of the axis: Y: Electric; several positions; Z: Electric; several positions

Required working stroke: Y: 200 mm; Working stroke in Z direction: Z: 50 mm

Take the strokes reserved into account in your specification.

Payload

Sum of the weight of the front unit and the workpiece: kg

Distance from the centre of the load: X: mm; Y: mm; Z: mm

Data protection:

Key features

Configurator: Handling Guide Online (HGO)

Result of calculation

You will be offered a selection of systems calculated based on the application data you entered.

The following are available immediately:

- CAD model
- Datasheet of the selected system
- Price information

Result of calculation
Select the appropriate system and continue with the configuration.

| No. | System series | System workload (%) | Repetition accuracy (µm) | Your price |
|-------------------------------------|---------------|---------------------|--------------------------|------------|
| <input checked="" type="checkbox"/> | 1 Y00M-1 | 11 % | 0.1 mm | |
| <input type="checkbox"/> | 5 Y00L-1 | 41 % | 0.08 mm | |
| <input type="checkbox"/> | 7 Y00L-0 | 55 % | 0.08 mm | |
| <input type="checkbox"/> | 9 Y00L-2 | 34 % | 0.08 mm | |
| <input type="checkbox"/> | 11 Y00L-2 | 25 % | 0.08 mm | |

Requires additional motion controller for interpolation (e.g. OPR-E-CEO-M1- ...)

2D linear gantry Y00M-1: #1

| | |
|--------------------------|----------------------------------|
| Drive module | Y2 module: Linear gantry EXCT-15 |
| Kinematics type | Parallel kinematics |
| Stroke | 200 mm/100 mm |
| Repetition accuracy (µm) | - |
| Clear unit | Without |
| Type of motor | Servo motor (SMM5-A5) |
| Motor position | Flange/Floor |
| Motor connection | 1700V AC 400V |

Data protection Back Continue

System overview

You will be given an overview of the complete system.

You will also have the following options:

- Show price
- Send request
- Add to basket

Your handling solution
Your selected system overview

Exemplary representation

©2022 powered by CADENAS
Update CAD Preview

Your system ID:
C2534095

Your next step:

[View price](#)

[Send request](#)

[Add to Cart](#)

Key features

Standard components within the handling system

The handling system comprises a number of tried-and-tested standard components from Festo. Different components are used depending on the configuration. The single axes installed will be displayed in the configurator HGO on the "Result of calculation" page.

Y-axis

Toothed belt axis EGC-TB-KF



- Electric system
- Rigid, closed profile
- Recirculating ball bearing guide for high loads and torques
- High dynamic response and minimum vibration

Toothed belt axis ELGC-TB



- Electric system
- Optimal installation space to working space ratio
- Protected against external influences by internal guide
- High dynamic response

Spindle axis ELGC-BS



- Electric system
- Optimal installation space to working space ratio
- Protected against external influences by internal guide
- Various spindle pitches

Toothed belt axis EGC-HD-TB



- Electric system
- Flat drive unit with rigid, closed profile
- Duo guide rail
- For maximum loads and torques, high feed forces and speeds and long service life

Z-axis

Mini slide EGSC



- Electric system
- Compact design
- High load capacity
- Precision guide and ball screw
- Easy adjustment of the end positions

Mini slide EGSL



- Electric system
- Compact design
- High load capacity
- High dynamic response
- Easy adjustment of the end positions

Mini slide DGST



- Pneumatic system
- Precise and resilient roller bearing guide
- Slide and yoke plate as a single component
- High dynamic response

Mini slide DGSL



- Pneumatic system
- Flat design
- High load capacity
- High dynamic response
- Easy adjustment of the end positions

Spindle axis EGC-BS-KF



- Electric system
- Rigid, closed profile
- Recirculating ball bearing guide for high loads and torques
- High dynamic response and minimum vibration
- Various spindle pitches

Cantilever axis ELCC



- Stationary drive head
- Toothed belt drive with recirculating ball bearing guide
- High rigidity thanks to the innovative design principle
- Very low moving mass

Key features

| Possible axis combinations ¹⁾ | | |
|--|--|---|
| Size | Y-module | Z-module |
| YXCL-1 | <ul style="list-style-type: none"> Toothed belt axis EGC-50-TB-KF | <ul style="list-style-type: none"> Mini slide pneumatic: DGSL-6 electric: EGSL-35 |
| YXCL-1-B | <ul style="list-style-type: none"> Toothed belt axis ELGC-60-TB Spindle axis ELGC-60-BS | <ul style="list-style-type: none"> Mini slide pneumatic: DGST-12/16 electric: EGSC-45 |
| YXCL-2 | <ul style="list-style-type: none"> Toothed belt axis EGC-80-TB-KF Toothed belt axis with heavy-duty guide EGC-HD-125-TB | <ul style="list-style-type: none"> Mini slide pneumatic: DGSL-12/16 electric: EGSL-45/55 Cantilever axis ELCC-60 Spindle axis EGC-70-BS-KF |
| YXCL-2-B | <ul style="list-style-type: none"> Toothed belt axis ELGC-80-TB Spindle axis ELGC-80-BS | <ul style="list-style-type: none"> Mini slide pneumatic: DGST-16/20 electric: EGSC-60 |
| YXCL-3 | <ul style="list-style-type: none"> Toothed belt axis EGC-120-TB-KF Toothed belt axis with heavy-duty guide EGC-HD-160-TB | <ul style="list-style-type: none"> Mini slide pneumatic: DGSL-20/25 electric: EGSL-75 Cantilever axis ELCC-70 Spindle axis EGC-80-BS-KF |
| YXCL-4 | <ul style="list-style-type: none"> Toothed belt axis EGC-185-TB-KF Toothed belt axis with heavy-duty guide EGC-HD-220-TB | <ul style="list-style-type: none"> Cantilever axis ELCC-90 Spindle axis EGC-120-BS-KF |
| YXML-1 | <ul style="list-style-type: none"> Linear gantry EXCT-15 | <ul style="list-style-type: none"> Linear gantry EXCT-15 |
| YXML-2 | <ul style="list-style-type: none"> Linear gantry EXCT-30 | <ul style="list-style-type: none"> Linear gantry EXCT-30 |
| YXML-3 | <ul style="list-style-type: none"> Linear gantry EXCT-100 | <ul style="list-style-type: none"> Linear gantry EXCT-100 |

1) Drive package depends on the configuration selected.

Key features

Standard components within the handling system

The handling system comprises a number of tried-and-tested standard components from Festo. Different components are used depending on the configuration. You can alter the scope and design of the drive package in the configurator HGO on the "System configuration" page.

Motors and controllers

Servo motors EMMT-AS



- Dynamic, brushless, permanently excited servo motor
- Digital absolute displacement encoder in single-turn or multi-turn version
- With optional brake

Servo motors EMME-AS



- Dynamic, brushless, permanently excited servo motor
- Digital absolute displacement encoder in single-turn or multi-turn version
- With optional brake

Servo motors EMMB-AS



- Dynamic, brushless, permanently excited servo motor
- Digital absolute displacement encoder in single-turn or multi-turn version
- With optional brake

Stepper motors EMMS-ST



- Two-phase hybrid technology
- Step angle 1.8°
- With optional brake

Gear unit EMGA



- Low-backlash planetary gear
- Gear ratio
 $i = 3$ and 5
- Life-time lubrication

Key features

Standard components within the handling system

The handling system comprises a number of tried-and-tested standard components from Festo. Different components are used depending on the configuration. You can alter the scope and design of the drive package in the configurator HGO on the "System configuration" page.

Servo drive CMMT-AS, for servo motor



- Universal servo drive
- For synchronous servo motors
- Integrated EMC filters
- Integrated brake chopper
- Integrated braking resistor
- Position controller
- Speed controller
- Force controller
- Range of control functions

Options:

- Safety function: safe torque off (STO)/category 4, Performance Level e
- Safe stop 1 (SS1)
- Safe brake control (SBC) up to SIL3/category 3, Performance Level e

- Bus protocols
 - EtherCAT
 - PROFINET RT/IRT
 - EtherNet/IP
 - Modbus TCP

Servo drive CMMT-ST, for stepper motor



- Servo drive for operating stepper motors and brushless direct current motors
- Options for point-to-point and interpolating motion and for precise positioning
- Primary voltage from 24 ... 48 V DC
- Position controller
- Speed controller
- Force controller
- Range of control functions

Options:

- Safety function: safe torque off (STO)/category 3, Performance Level e
- Safe stop 1 time controlled (SS1-t)

- Bus protocols
 - EtherCAT
 - PROFINET RT/IRT
 - EtherNet/IP
 - Modbus TCP

Ordering data – Accessories

Module/motor combinations

We recommend that the linear gantry is operated with the proposed motors from Festo. These precisely match the mechanical system. When using third-party motors, it is essential that the technical limits are observed.

| Module | Motor | | Stepper motor |
|-------------------------|------------------------|----------------------|------------------|
| | Servo motor | | |
| Y-module | | | |
| EHMY-...-EGC-50-TB-KF | – | EMME-AS-40-S-LV-... | EMMS-ST-57-M-... |
| EHMY-...-EGC-80-TB-KF | EMMT-AS-60-S-LS-... | EMME-AS-60-M-LS-... | EMMS-ST-57-S-... |
| EHMY-...-EGC-120-TB-KF | EMMT-AS-80-L-LS-... | EMME-AS-80-S-LS-... | EMMS-ST-87-S-... |
| | EMMT-AS-80-L-HS-... | – | – |
| EHMY-...-EGC-125-TB-HD | EMMT-AS-60-L-LS-... | EMME-AS-60-M-LS-... | EMMS-ST-57-S-... |
| EHMY-...-EGC-160-TB-HD | EMMT-AS-80-M-LS-... | EMME-AS-80-S-LS-... | EMMS-ST-87-S-... |
| | EMMT-AS-80-L-HS-... | – | – |
| EHMY-...-EGC-185-TB-KF | EMMT-AS-100-L-HS-... | EMME-AS-100-M-HS-... | – |
| | EMMT-AS-100-H-HS-... | – | – |
| | EMMT-AS-150-M-HV-R3... | – | – |
| EHMY-...-EGC-220-TB-HD | EMMT-AS-100-L-HS-... | EMME-AS-100-M-HS-... | – |
| | EMMT-AS-100-H-HS-... | – | – |
| | EMMT-AS-150-M-HV-R3... | – | – |
| EHMY-LP-ELGC-60-BS | – | – | EMMB-AS-60-04 |
| EHMY-LP-ELGC-80-BS | – | – | EMMB-AS-60-04 |
| EHMY-LP-ELGC-60-TB | – | – | EMMB-AS-80-07 |
| EHMY-LP-ELGC-80-TB | – | – | EMMB-AS-80-07 |
| Z-module | | | |
| EHMZ-ELCC-60-TB-KF | EMMT-AS-60-M-LS-... | – | – |
| | EMMT-AS-80-L-LS-... | – | – |
| | EMMT-AS-100-S-HS-... | – | – |
| EHMZ-ELCC-70-TB-KF | EMMT-AS-80-M-LS-... | – | – |
| | EMMT-AS-80-L-HS-... | – | – |
| EHMZ-ELCC-90-TB-KF | EMMT-AS-80-L-HS-... | – | – |
| | EMMT-AS-100-L-HS-... | – | – |
| | EMMT-AS-100-H-HS-... | – | – |
| EHMZ-EGC-70-BS-KF | EMMT-AS-60-S-LS-... | EMME-AS-60-M-LS-... | EMMS-ST-57-S-... |
| EHMZ-EGC-80-BS-KF | EMMT-AS-60-M-LS-... | EMME-AS-60-M-LS-... | EMMS-ST-57-S-... |
| EHMZ-EGC-120-BS-KF | EMMT-AS-80-S-LS-... | EMME-AS-80-S-LS-... | – |
| | EMMT-AS-80-M-LS-... | – | – |
| | EMMT-AS-80-S-HS-... | – | – |
| | EMMT-AS-80-L-HS-... | – | – |
| EHMZ-EGSL-35-BS-KF | – | EMME-AS-40-S-LV-... | EMMS-ST-28-L-... |
| EHMZ-EGSL-45-BS-KF | EMMT-AS-60-S-LS-... | EMME-AS-40-S-LV-... | EMMS-ST-57-S-... |
| EHMZ-EGSL-55-BS-KF | EMMT-AS-60-S-LS-... | EMME-AS-60-M-LS-... | EMMS-ST-57-S-... |
| EHMZ-EGSL-75-BS-KF | EMMT-AS-80-S-LS-... | EMME-AS-80-S-LS-... | EMMS-ST-87-S-... |
| EHMZ-EGSC-45 | – | – | EMMB-AS-40-01 |
| EHMZ-EGSC-60 | – | – | EMMB-AS-60-02 |
| YZ-module (EXCT) | | | |
| EXCT-15 | EMMT-AS-80-M-LS-... | – | – |
| EXCT-30 | EMMT-AS-100-M-HS-... | – | – |
| EXCT-100 | EMMT-AS-100-M-HS-... | – | – |

Ordering data – Accessories

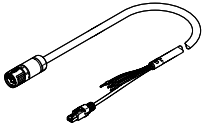
| Ordering data | Description | Cable length [m] | Part no. | Type |
|---|--|------------------|--------------------------------|---------------------------------|
| For servo motor EMMT-AS | | | | |
| Motor cable | | | | |
|  | • For EMMT-AS-60/80-...-R2... with CMMT-AS | 2.5 | 5251374 | NEBM-M23G15-EH-2.5-Q7N-R3LEG14 |
| | | 5 | 5251375 | NEBM-M23G15-EH-5-Q7N-R3LEG14 |
| | | 7.5 | 5251376 | NEBM-M23G15-EH-7.5-Q7N-R3LEG14 |
| | | 10 | 5251377 | NEBM-M23G15-EH-10-Q7N-R3LEG14 |
| | | 15 | 5251378 | NEBM-M23G15-EH-15-Q7N-R3LEG14 |
| | | 20 | 5251379 | NEBM-M23G15-EH-20-Q7N-R3LEG14 |
| | • For EMMT-AS-100-...-R2... with CMMT-AS | 2.5 | 5251381 | NEBM-M23G15-EH-2.5-Q9N-R3LEG14 |
| | | 5 | 5251382 | NEBM-M23G15-EH-5-Q9N-R3LEG14 |
| | | 7.5 | 5251383 | NEBM-M23G15-EH-7.5-Q9N-R3LEG14 |
| | | 10 | 5251384 | NEBM-M23G15-EH-10-Q9N-R3LEG14 |
| | | 15 | 5251385 | NEBM-M23G15-EH-15-Q9N-R3LEG14 |
| | | 20 | 5251386 | NEBM-M23G15-EH-20-Q9N-R3LEG14 |
| | • For EMMT-AS-150-...-R3... with CMMT-AS | 2.5 | 5251395 | NEBM-M40G15-EH-2.5-Q11N-R3LEG14 |
| | | 5 | 5251396 | NEBM-M40G15-EH-5-Q11N-R3LEG14 |
| | | 7.5 | 5251397 | NEBM-M40G15-EH-7.5-Q11N-R3LEG14 |
| 10 | | 5251398 | NEBM-M40G15-EH-10-Q11N-R3LEG14 | |
| 15 | | 5251399 | NEBM-M40G15-EH-15-Q11N-R3LEG14 | |
| 20 | | 5251400 | NEBM-M40G15-EH-20-Q11N-R3LEG14 | |

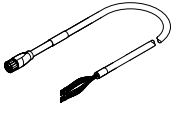
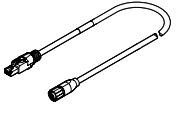

| Ordering data | Description | Cable length [m] | Part no. | Type |
|---|---|------------------|----------|---------------------------|
| For servo motor EMME-AS | | | | |
| Motor cable | | | | |
|  | • For EMME-AS-40/60 with CMMT-AS | 2.5 | 5391541 | NEBM-M16G8-E-2.5-Q7-LE8-1 |
| | | 5 | 5391543 | NEBM-M16G8-E-5-Q7-LE8-1 |
| | | 7.5 | 5391548 | NEBM-M16G8-E-7.5-Q7-LE8-1 |
| | | 10 | 8085952 | NEBM-M16G8-E-10-Q7-LE8-1 |
| | | 15 | 8085953 | NEBM-M16G8-E-15-Q7-LE8-1 |
| | | 20 | 611113 | NEBM-M16G8-E-20-Q7-LE8-1 |
| | • For EMME-AS-80/100 with CMMT-AS | 2.5 | 5391540 | NEBM-M16G8-E-2.5-Q9-LE8-1 |
| | | 5 | 5391545 | NEBM-M16G8-E-5-Q9-LE8-1 |
| | | 7.5 | 5391547 | NEBM-M16G8-E-7.5-Q9-LE8-1 |
| | | 10 | 5391549 | NEBM-M16G8-E-10-Q9-LE8-1 |
| | | 15 | 5391550 | NEBM-M16G8-E-15-Q9-LE8-1 |
| | | 20 | 611114 | NEBM-M16G8-E-20-Q9-LE8-1 |
| Encoder cable | | | | |
|  | • For EMME-AS-40/60/80/100 with CMMT-AS | 2.5 | 5212312 | NEBM-M12G8-E-2.5-N-R3G8 |
| | | 5 | 5212313 | NEBM-M12G8-E-5-N-R3G8 |
| | | 7.5 | 5212314 | NEBM-M12G8-E-7.5-N-R3G8 |
| | | 10 | 5212315 | NEBM-M12G8-E-10-N-R3G8 |
| | | 15 | 5212316 | NEBM-M12G8-E-15-N-R3G8 |
| | | 20 | 611112 | NEBM-M12G8-E-20-N-R3G8 |

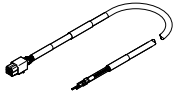
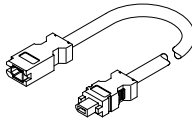
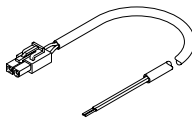
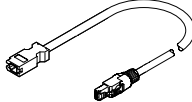
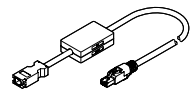
Ordering data – Accessories

| Ordering data | | Cable length [m] | Part no. | Type |
|--|---|------------------------|---------------------------|------|
| For servo motor EMMB-AS | | | | |
| Motor cable | | | | |
|  <ul style="list-style-type: none"> For EMMB-AS-40/60/80 with CMMT-AS | 2.5 | 5219197 | NEBM-H6G4-E-2.5-Q13N-LE4 | |
| | 5 | 5219198 | NEBM-H6G4-E-5-Q13N-LE4 | |
| | 7.5 | 5219199 | NEBM-H6G4-E-7.5-Q13N-LE4 | |
| | 10 | 5219200 | NEBM-H6G4-E-10-Q13N-LE4 | |
| | 15 | 8097203 | NEBM-H6G4-E-15-Q13N-LE4 | |
| Encoder cable | | | | |
|  <ul style="list-style-type: none"> For EMMB-AS-40/60/80 with CMMT-AS | 2.5 | 5219213 | NEBM-REG6-E-2.5-Q14N-REG6 | |
| | 5 | 5219214 | NEBM-REG6-E-5-Q14N-REG6 | |
| | 7.5 | 5219215 | NEBM-REG6-E-7.5-Q14N-REG6 | |
| | 10 | 5219216 | NEBM-REG6-E-10-Q14N-REG6 | |
| | 15 | 8097200 | NEBM-REG6-E-15-Q14N-REG6 | |
| Connecting cable for brake | | | | |
|  <ul style="list-style-type: none"> For EMMB-AS-40/60/80 with CMMT-AS | 2.5 | 5219205 | NEBM-H7G2-E-2.5-Q14N-LE2 | |
| | 5 | 5219206 | NEBM-H7G2-E-5-Q14N-LE2 | |
| | 7.5 | 5219207 | NEBM-H7G2-E-7.5-Q14N-LE2 | |
| | 10 | 5219208 | NEBM-H7G2-E-10-Q14N-LE2 | |
| | 15 | 8097206 | NEBM-H7G2-E-15-Q14N-LE2 | |
| Adapter for encoder cable (absolutely essential) | | | | |
|  <ul style="list-style-type: none"> For EMMB-AS-40/60/80 with CMMT-AS | For single-turn version with CMMT-AS | | | |
| | 0.5 | 8097197 | NEFM-REG6-K-0.5-R3G8 | |
|  <ul style="list-style-type: none"> For EMMB-AS-40/60/80 with CMMT-AS | For multi-turn version with CMMT-AS¹⁾ | | | |
| | 0.5 | 8097195 | NEFM-REG6-K-0.5-B-R3G8 | |
| | For multi-turn version with CMMB-AS¹⁾ | | | |
| 0.5 | 8097196 | NEFM-REG6-K-0.5-B-REG6 | | |

1) The required battery is not included in the scope of delivery

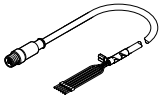
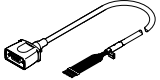
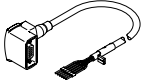
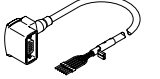
Ordering data – Accessories

| Designation | Description | Cable length [m] | Part no. | Type |
|---|---|------------------|----------|--------------------------|
| For stepper motor EMMS-ST | | | | |
| Motor cable¹⁾ | | | | |
|  | • For stepper motor EMMS-ST-28 with CMMT-ST | 1.5 | 1449600 | NEBM-SM12G8-E-1.5-Q5-LE6 |
| | | 2.5 | 1449601 | NEBM-SM12G8-E-2.5-Q5-LE6 |
| | | 5 | 1449602 | NEBM-SM12G8-E-5-Q5-LE6 |
| | | 7 | 1449603 | NEBM-SM12G8-E-7-Q5-LE6 |
| | | 10 | 1449604 | NEBM-SM12G8-E-10-Q5-LE6 |
| | | 15 | 5105618 | NEBM-SM12G8-E-15-Q5-LE6 |
|  | • For stepper motor EMMS-ST-42/57 with CMMT-ST • Straight plug | 2.5 | 1450369 | NEBM-S1G9-E-2.5-Q5-LE6 |
| | | 5 | 1450370 | NEBM-S1G9-E-5-Q5-LE6 |
| | | 7 | 1450371 | NEBM-S1G9-E-7-Q5-LE6 |
| | | 10 | 1450372 | NEBM-S1G9-E-10-Q5-LE6 |
| | | 15 | 5085055 | NEBM-S1G9-E-15-Q5-LE6 |
| | | 20 | 5085056 | NEBM-S1G9-E-20-Q5-LE6 |
|  | • For stepper motor EMMS-ST-42/57 with CMMT-ST • Angled plug | 2.5 | 1450737 | NEBM-S1W9-E-2.5-Q5-LE6 |
| | | 5 | 1450738 | NEBM-S1W9-E-5-Q5-LE6 |
| | | 7 | 1450739 | NEBM-S1W9-E-7-Q5-LE6 |
| | | 10 | 1450740 | NEBM-S1W9-E-10-Q5-LE6 |
| | | 15 | 610856 | NEBM-S1W9-E-15-Q5-LE6 |
|  | • For stepper motor EMMS-ST-87 with CMMT-ST • Angled plug | 2.5 | 1450944 | NEBM-S1W15-E-2.5-Q7-LE6 |
| | | 5.0 | 1450945 | NEBM-S1W15-E-5-Q7-LE6 |
| | | 7.0 | 1450946 | NEBM-S1W15-E-7-Q7-LE6 |
| | | 10 | 1450947 | NEBM-S1W15-E-10-Q7-LE6 |
| | | 15 | 610857 | NEBM-S1W15-E-15-Q7-LE6 |
| Encoder cable¹⁾ | | | | |
|  | • For stepper motor EMMS-ST-28/42/57/87 with CMMT-ST • Straight plug | 2.5 | 1451587 | NEBM-M12G8-E-2.5-LE8 |
| | | 5 | 1451588 | NEBM-M12G8-E-5-LE8 |
| | | 7 | 1451589 | NEBM-M12G8-E-7-LE8 |
| | | 10 | 1451590 | NEBM-M12G8-E-10-LE8 |
| | | 15 | 611110 | NEBM-M12G8-E-15-LE8 |
|  | • For stepper motor EMMS-ST-28/42/57/87 with CMMT-ST • Angled plug | 2.5 | 1451675 | NEBM-M12W8-E-2.5-LE8 |
| | | 5 | 1451676 | NEBM-M12W8-E-5-LE8 |
| | | 7 | 1451677 | NEBM-M12W8-E-7-LE8 |
| | | 10 | 1451678 | NEBM-M12W8-E-10-LE8 |
| | | 15 | 610858 | NEBM-M12W8-E-15-LE8 |

1) Cables especially suitable for the motor controller and motor.
Degree of protection to IP65 (in assembled state)

Possible cable and tube lengths

- Cables and tubing are selected so that the length specified when ordering will be the minimum connection length from the energy chain output.
- Cables and tubing are only available in fixed lengths as stated in the table below. This can mean that the cable plugs of the different cables do not end at the same point.

| Length | 1 m | 2 m | 5 m | 7 m | 10 m |
|---------------------------------|-----|-----|-----|-----|------|
| Motor cable | – | ■ | ■ | ■ | ■ |
| Encoder cable | – | ■ | ■ | ■ | ■ |
| Multi-pin plug connecting cable | – | ■ | ■ | ■ | ■ |
| Tubing (for DHMZ only) | ■ | ■ | ■ | – | – |

Ordering data – Accessories

Standard components within the handling system



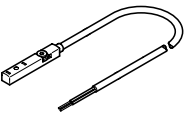
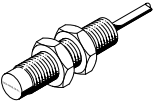
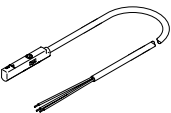
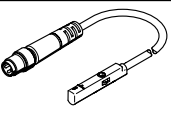
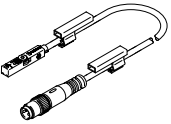
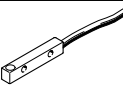

The handling system comprises a number of tried-and-tested standard components from Festo. Different components are used depending on the configuration. You can alter the scope and design of the accessories in the configurator HGO on the "System configuration" page.

| Designation | Description | Cable length [m] | Part no. | Type | |
|---|--|------------------|----------|---------------------------|----------------------------|
| Proximity switch (inductive) for sensing the position of the slide on the Y-/Z-axis | | | | | |
|  | Cable with open end | | | | |
| | <ul style="list-style-type: none"> For toothed belt axis EGC-TB, EGC-HD-TB For toothed belt axis ELGC-TB For spindle axis ELGC-BS For spindle axis EGC-BS For mini slide EGSL For mini slide EGSC For DC voltage Included if the "Festo sensor package" is selected: <ul style="list-style-type: none"> For EGC: 2 pieces For EGSL, EGSC: 1 piece | PNP, N/C contact | 7.5 | 551391 | SIES-8M-PO-24V-K-7.5-OE |
| | | PNP, N/O contact | 7.5 | 551386 | SIES-8M-PS-24V-K-7.5-OE |
| | | NPN, N/C contact | 7.5 | 551401 | SIES-8M-NO-24V-K-7.5-OE |
| | | NPN, N/O contact | 7.5 | 551396 | SIES-8M-NS-24V-K-7.5-OE |
| Proximity switch (inductive) for sensing the position of the slide on the Z-axis | | | | | |
|  | Cable with open end | | | | |
| | <ul style="list-style-type: none"> For cantilever axis ELCC For DC voltage Included if the "Festo sensor package" is selected: <ul style="list-style-type: none"> 2 pieces | PNP, N/C contact | 2.5 | 150398 | SIEN-M8NB-PO-K-L |
| | | PNP, N/O contact | 2.5 | 150394 | SIEN-M8NB-PS-K-L |
| | | NPN, N/C contact | 2.5 | 150396 | SIEN-M8NB-NO-K-L |
| NPN, N/O contact | | 2.5 | 150392 | SIEN-M8NB-NS-K-L | |
| Proximity switches (magneto-resistive) for sensing the position of the slide on the Z-axis | | | | | |
|  | Cable with open end | | | | |
| | <ul style="list-style-type: none"> For mini slide DGSL For DC voltage Included if the "Festo sensor package" is selected: <ul style="list-style-type: none"> 2 pieces | PNP, N/O contact | 2.5 | 551373 | SMT-10M-PS-24V-E-2.5-L-OE |
| NPN, N/O contact | | 2.5 | 551377 | SMT-10M-NS-24V-E-2.5-L-OE | |
| Proximity switches (magneto-resistive) for sensing the position of the slide on the Z-axis | | | | | |
|  | <ul style="list-style-type: none"> For mini slide DGST-8/-12 For DC voltage Included if the "Festo sensor package" is selected: <ul style="list-style-type: none"> 2 pieces | PNP, N/O contact | 2.5 | 551375 | SMT-10M-PS-24V-E-0.3-L-M8D |
| | | NPN, N/O contact | 2.5 | 551379 | SMT-10M-NS-24V-E-0.3-L-M8D |
|  | <ul style="list-style-type: none"> For mini slide DGST-16/-20 For DC voltage Included if the "Festo sensor package" is selected: <ul style="list-style-type: none"> 2 pieces | PNP, N/O contact | 2.5 | 574334 | SMT-8M-A-PS-24V-E-0.3-M8D |
| | | NPN, N/O contact | 2.5 | 574339 | SMT-8M-A-NS-24V-E-0.3-M8D |
| Proximity switch for sensing the position of the slide on the Y-/Z-axis | | | | | |
|  | <ul style="list-style-type: none"> For EXCT For DC voltage For sensing kit EAPR-E17 | PNP, N/C contact | 2.5 | 174552 | SIES-Q8B-PO-K-L |
| | | PNP, N/O contact | 2.5 | 178294 | SIES-Q8B-PS-K-L |
| | | NPN, N/C contact | 2.5 | 174550 | SIES-Q8B-NO-K-L |
| | | NPN, N/O contact | 2.5 | 178292 | SIES-Q8B-NS-K-L |

Ordering data – Accessories

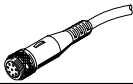
Standard components within the handling system

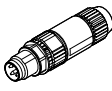
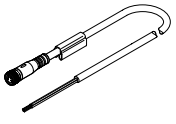
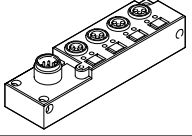
The handling system comprises a number of tried-and-tested standard components from Festo. Different components are used depending on the configuration. You can alter the scope and design of the accessories in the configurator HGO on the "System configuration" page.

| Designation | Description | Cable length [m] | Part no. | Type |
|---|---|------------------|----------|--------------------------|
| Plug socket with cable | | | | |
|  | <ul style="list-style-type: none"> • Connection between multi-pin plug distributor NEDU and control cabinet | 5 | 525618 | SIM-M12-8GD-5-PU |
| | | 10 | 570008 | SIM-M12-8GD-10-PU |
| Plug socket with cable | | | | |
|  | <ul style="list-style-type: none"> • For EXCT • For multi-pin SET EADH | 15 | 8048086 | NEBU-M12W8-K-15-N-LE8 |
| Plug | | | | |
|  | <ul style="list-style-type: none"> • For connection to the multi-pin plug distributor NEDU / distributor NEDY | – | 562024 | NECU-S-M8G3-HX |
| Connecting cable | | | | |
|  | <ul style="list-style-type: none"> • Connection between distributor NEDY and control cabinet | 2.5 | 541342 | NEBU-M8G4-K-2.5-LE4 |
| | | 5 | 541343 | NEBU-M8G4-K-5-LE4 |
| | | 7.5 | 610854 | NEBU-M8G4-K-7.5-LE4 |
| | | 10 | 589560 | NEBU-M8G4-K-10-LE4 |
| | | 15 | 610855 | NEBU-M8G4-K-15-LE4 |
| Multi-pin plug distributor | | | | |
|  | <ul style="list-style-type: none"> • With the help of the multi-pin plug distributor, all electrical signals such as for end-position sensing can be transferred Options: <ul style="list-style-type: none"> – 4 individual connections – 6 individual connections | – | 574586 | NEDU-L4R1-M8G3L-M12G8 |
| | | | 574587 | NEDU-L6R1-M8G3L-M12G8 |
|  | <ul style="list-style-type: none"> • With the help of the distributor, all electrical signals such as for end-position sensing can be transferred – 2 individual connections | – | 8005312 | NEDY-L2R1-V1-M8G3-N-M8G4 |

Ordering data – Accessories

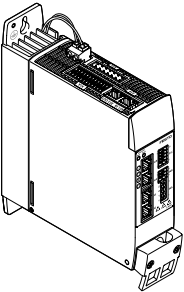
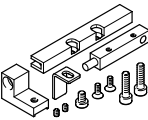
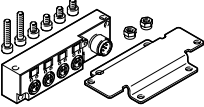
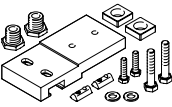
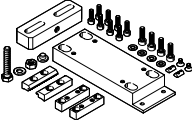
| Designation | Description | Part no. | Type |
|--|---|------------------------|--|
| Motor controller/servo drive | | | |
|  | The accessories for the relevant motor controllers/servo drives can be found at: <ul style="list-style-type: none"> • www.festo.com/catalogue/cmmt | | |
| Sensing kit | | | |
|  | <ul style="list-style-type: none"> • For EXCT • Included in the scope of delivery: proximity switch SIES-Q8B, sensor bracket, switch lug, mounting bracket and screws | PNP, N/C contact | 8092368 EAPR-E17-S1 |
| | | PNP, N/O contact | 2478427 EAPR-E17-S |
| | | NPN, N/C contact | 8092369 EAPR-E17-S3 |
| | | NPN, N/O contact | 8092370 EAPR-E17-S4 |
| Multi-pin set | | | |
|  | <ul style="list-style-type: none"> • For EXCT • For connecting up to 4 inputs/outputs | 2972137 | EADH-E17-MP1 |
| | | | |
| Mounting kit | | | |
|  | <ul style="list-style-type: none"> • For EXCT • For mounting and aligning on a supporting surface • The kit is height-adjustable | EXCT-15 | 3838164 EAHM-E17-K2-15 |
| | | EXCT-30 | 3838337 EAHM-E17-K2-30 |
| | | EXCT-100 | 3838404 EAHM-E17-K2-100 |
| Adjusting kit | | | |
|  | <ul style="list-style-type: none"> • Used to mount the handling system on a vertical surface • Once mounted, the axis can be aligned horizontally | EHMY-...-EGC-50-TB-KF | 8047576 EADC-E16-50-E7 |
| | | EHMY-...-EGC-80-TB-KF | 8047577 EADC-E16-80-E7 |
| | | EHMY-...-EGC-120-TB-KF | 8047578 EADC-E16-120-E7 |
| | | EHMY-...-EGC-185-TB-KF | 8047579 EADC-E16-185-E7 |
| | | EHMY-...-EGC-125-TB-HD | 8047580 EADC-E16-125-E14 |
| | | EHMY-...-EGC-160-TB-HD | 8047581 EADC-E16-160-E14 |
| | | EHMY-...-EGC-220-TB-HD | 8047582 EADC-E16-220-E14 |
| | | EHMY-...-ELGC-60-BS | 8142654 EADC-E16-60-E22 |
| EHMY-...-ELGC-80-BS | 8142655 EADC-E16-80-E22 | | |

Programming aid

Festo Automation Suite

Parameterisation and programming software for electronic devices from Festo

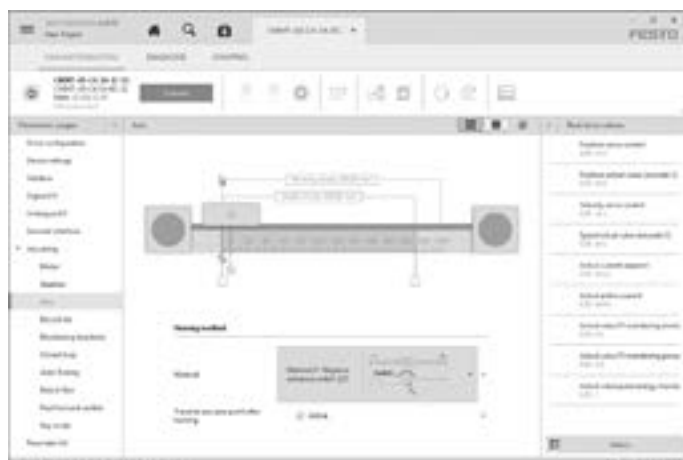

- Parameterisation, programming and commissioning in a clear and user-friendly interface
- Optimum support for complex processes thanks to guided wizards (e.g. for commissioning, drive configuration, etc.)
- Fast access to the required documents and additional information
- Easy integration of electric drives in the controller programming