

## Linear drives SLG, flat design

**FESTO**



## Key features

### General

- Piston  $\varnothing$  8, 12 and 18
- Stroke lengths from 100 ... 900 mm
- Choice of two cushioning types:
  - Elastic cushioning
  - Shock absorber
- Direct mounting via centring holes
- Extremely flat design
- Integrated precision guide
- Slide with polished surface
- High load capacity
- Adjustable end stops
- Versatile supply port options
- Suitable for multiple-axis applications with other mini slides

### The technology in detail



- [1] End stops:  
Finely-adjustable end stops over entire stroke range
- [2] Guide rail:  
Very accurate, precise and rigid guide unit: stainless steel roller track pressed into aluminium profile with ball guide
- [3] Slide:  
Interface for attachments. Very flexible thanks to wide choice of mounting and attachment options
- [4] Cushioning:  
With rubber buffer or with shock absorber. The cushioning elements are inserted into the slide and fixed.
- [5] Supply port:  
Option on three sides
- [6] Slot for integrated proximity switches SME-/SMT-10

### Design

#### The flat linear drive SLG

The height H remains the same even if the intermediate-position module is used.

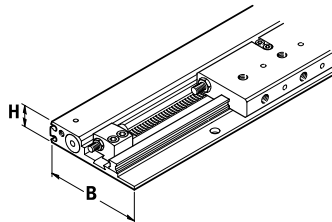

Piston $\varnothing$	Width (W)	x	Height (H)
8 mm	53.5	x	15 mm
12 mm	64.5	x	18.5 mm
18 mm	85.5	x	25.5 mm

## Key features

### Intermediate positions – simple and inexpensive

- The intermediate-position module can be used for advancing to one or more intermediate positions
- It is mounted parallel to the linear drive SLG via an additional profile rail. This also simplifies retrofitting.
- Precision adjustment of the intermediate position is carried out via a stop screw with lock nut
- With two modules the same position can be approached from either direction
- The intermediate positions can be freely selected across the entire stroke range (observe minimum distances)
- The module's symmetry means that it can advance to the right or left once mounted
- It can be activated and sensed before the movement starts
- The intermediate position (activated or initial position) can be sensed contactlessly using integrated proximity switches in the module housing
- Up to 4 modules can be ordered via the SLG modular product system
- The slide must be retracted once the intermediate position is reached. The stop on the module can then swivel back into its initial position

### Completely assembled with two intermediate positions

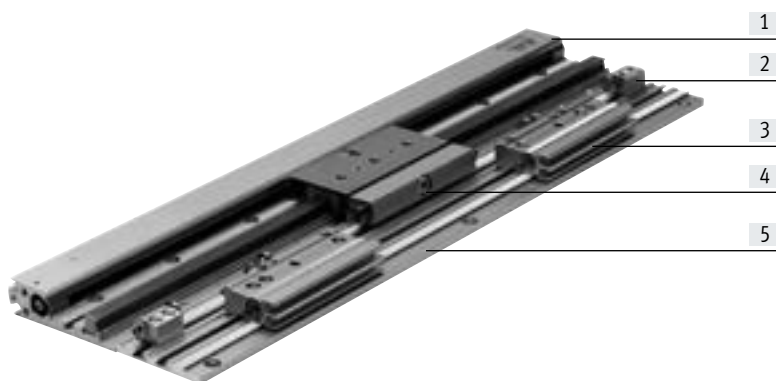

- [1] Linear drive
- [2] End stop
- [3] Intermediate-position module SLG-Z: The stop with buffer screw is retracted and advanced by a 90° swivel motion based on a double-acting semi-rotary drive (rack and pinion principle). The module is fastened to the mounting rail using screws and slot nuts.
- [4] Cushioning mount SLG-D: The mount holds the rubber buffers or shock absorbers and is attached to the slide of the SLG. The use of shock absorbers YSRG (Accessories → page 25) is recommended to ensure accurate positioning of stops and in the case of the vertical mounting positions.
- [5] Mounting rail SLG-S: The rail is used for mounting the intermediate-position modules. It can also accommodate the end stops of the linear drive SLG. The gear teeth on the rail and module permit rough pre-adjustment with respect to the drive SLG.

#### Note

The intermediate-position module can also be used independently of the linear drive SLG. In this case, the module is simply mounted on any flat surface using retaining screws and dowel pins and can then be used universally as an autonomous intermediate-position module in numerous applications.

Peripherals overview

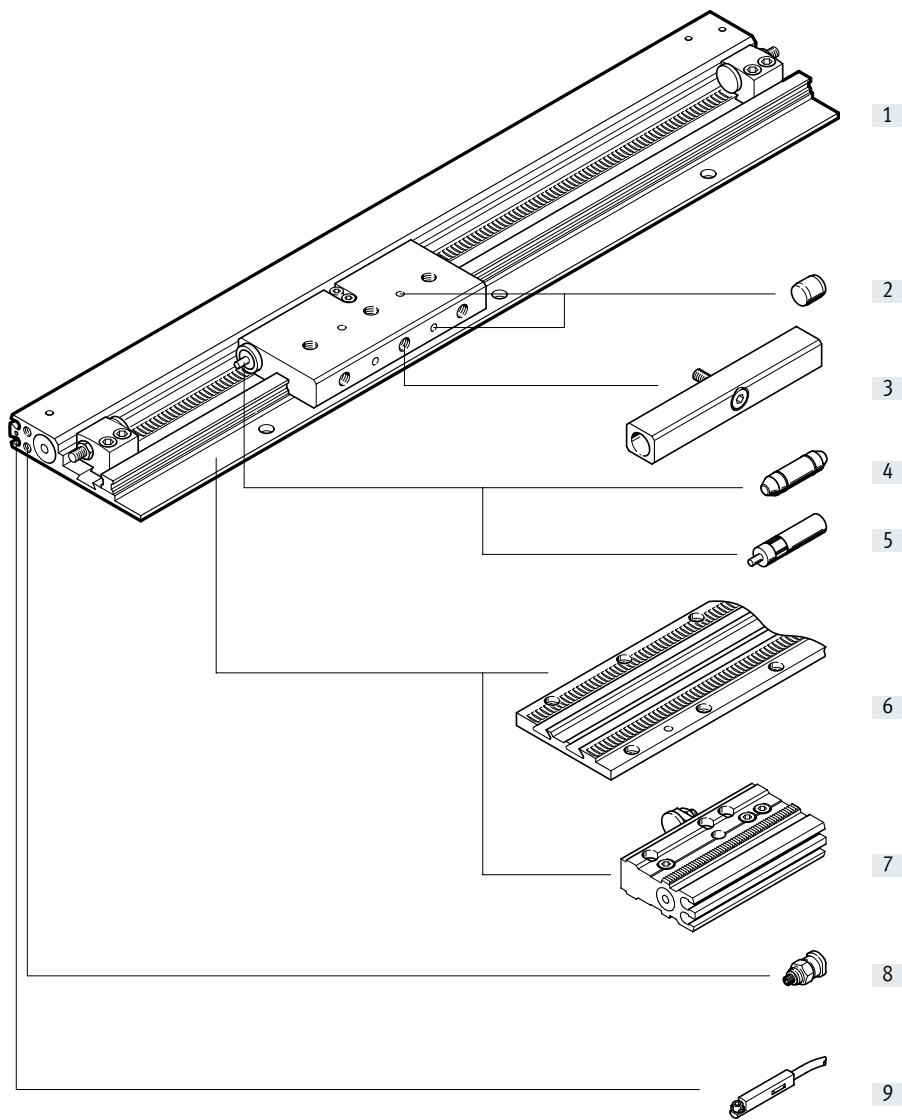

## Peripherals overview

Variants and accessories		
Type	Description	→ Page/Internet
[1] Linear drive SLG	Drive without accessories	6
[2] Centring pin ZBS	For centring loads and attachments on the slide	25
[3] Cushioning mount SLG-D	For fastening the rubber buffers or shock absorbers in combination with the intermediate-position module	23
[4] Rubber buffer SLG	Non-adjustable, elastic cushioning. Only used for low speeds	25
[5] Shock absorber YSRG	Self-adjusting, hydraulic shock absorber with spring return and linear cushioning characteristics	25
[6] Mounting rail SLG-S	For fastening the intermediate-position modules and end stops	24
[7] Intermediate-position module SLG-Z	Fixed stop for the intermediate position	16
[8] One-way flow control valve GRLA	The small distance between the supply ports means that only certain one-way flow control valves can be used	26
[9] Proximity switch SME-/SMT-10	The proximity switches are fitted in the profile slot. so that they do not protrude	26

## Type codes

001	Series
SLG	Linear drive

002	Piston diameter
8	8
12	12
18	18

003	Stroke
...	100 ... 900

004	Cushioning
P	Elastic cushioning rings/plates on both sides
YSR	Self-adjusting shock absorber

  

005	Position sensing
A	For proximity sensor

006	Intermediate position
Z1	1 intermediate position
Z2	2 intermediate positions
Z3	3 intermediate positions
Z4	4 intermediate positions

## Data sheet

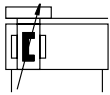

- Diameter  
8 ... 18 mm
- Stroke length  
100 ... 900 mm

**General technical data**

Piston $\varnothing$	8	12	18
Stroke <sup>1)</sup> [mm]	100 ... 500	100 ... 700	100 ... 900
Pneumatic connection	M3		M5
Mode of operation	Double-acting		
Operating medium	Compressed air to ISO 8573-1:2010 [7:--:-]		
Note on operating/ pilot medium	Lubricated operation possible (in which case lubricated operation will always be required)		
Design	Rodless drive		
Cushioning → Page 10	Elastic cushioning rings/pads at both ends Self-adjusting at both ends		
Position sensing	Via proximity switch		
Type of mounting	Direct mounting		
Mounting position	Any		
Driver principle	Slotted cylinder, mechanically coupled		
Guide	Guide rail with slide		
Max. speed [m/s]	1		1.5

1) Intermediate strokes are infinitely adjustable with stops

**Operating and environmental conditions**

Piston $\varnothing$	8	12	18
Operating pressure [bar]	2.5 ... 8	2 ... 8	1 ... 8
Ambient temperature <sup>1)</sup> [°C]	-10 ... +60		

1) Note operating range of proximity switches

**Forces [N]**

Piston $\varnothing$	8	12	18
Theoretical force at 6 bar	30	68	153

## Data sheet

<b>Weight [g]</b>			
Piston ø	8	12	18
Basic weight per 0 mm stroke With cushioning P	215	410	965
Basic weight per 0 mm stroke With cushioning YSR	225	420	995
Additional weight per 10 mm stroke	11.5	17.5	29.5
Moving mass With cushioning P	80	160	440
Moving mass With cushioning YSR	90	170	470

### Materials

Sectional view

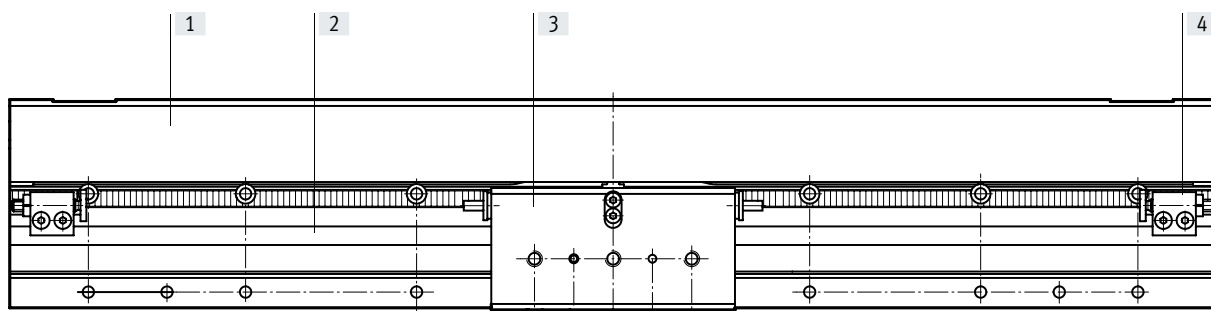

Linear drives

[1]	Profile barrel	Anodised aluminium
[2]	Guide	High-alloy steel
[3]	Slide	High-alloy steel
[4]	Stop housing	Anodised aluminium
-	Seals	Polyurethane
	Note on materials	Free of copper and PTFE



## Data sheet

### Characteristic load values

The indicated forces and torques refer to the centre of the guide rail.

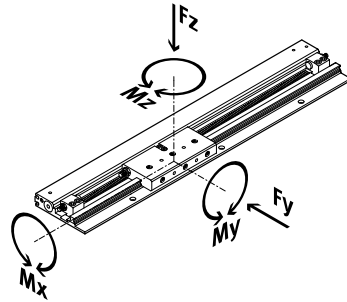

If the drive is simultaneously subjected to several of the indicated forces and torques, the following equation must be satisfied in addition to the indicated maximum loads:

$$f_v = \frac{|F_{y1}|}{F_{y2}} + \frac{|F_{z1}|}{F_{z2}} + \frac{|M_{x1}|}{M_{x2}} + \frac{|M_{y1}|}{M_{y2}} + \frac{|M_{z1}|}{M_{z2}} \leq 1$$

Permissible forces [N] and torques [Nm]				
Piston $\varnothing$		8	12	18
$F_{y_{max}}$	[N]	255	565	930
$F_{z_{max}}$	[N]	255	565	930
$M_{x_{max}}$	[Nm]	1	3	7
$M_{y_{max}}$	[Nm]	3.5	9	23
$M_{z_{max}}$	[Nm]	3.5	9	23

Torsional backlash [°] at the respective torques				
Piston $\varnothing$		8	12	18
At $M_{x_{max}}$		$\pm 0.03$	$\pm 0.04$	$\pm 0.05$
At $M_{y_{max}}$		$\pm 0.005$	$\pm 0.007$	$\pm 0.007$
At $M_{z_{max}}$		$\pm 0.005$	$\pm 0.007$	$\pm 0.007$

## Data sheet

### Maximum permissible piston speed $v$ as a function of payload $m$ when the unit is operated horizontally

As a function of operating pressure and end-position cushioning system

A linear drive SLG with cushioning YSR (shock absorbers YSRG) must be used in applications requiring very high repetition accuracy.

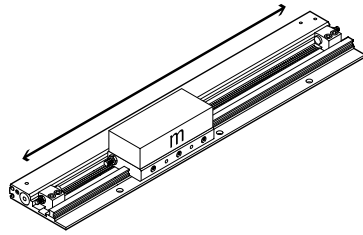

#### Cushioning P

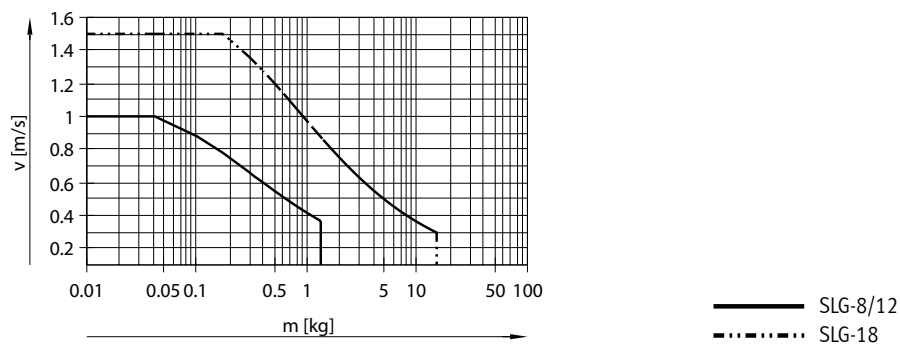

#### Cushioning YSR

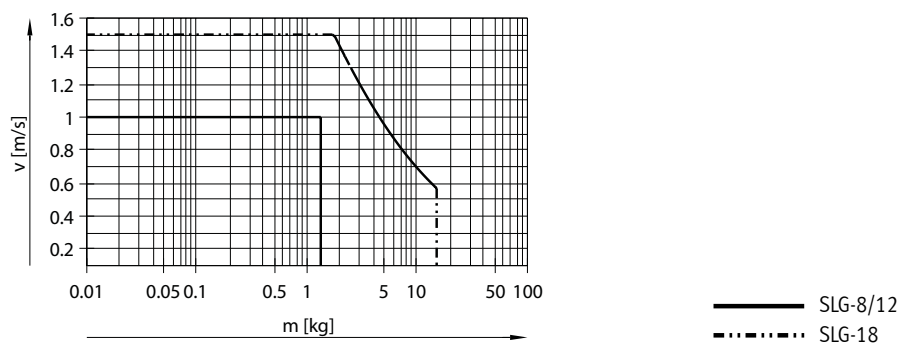

## Data sheet

### Determining the required points of support as a function of the weight force F

The support spacings  $L$  must be laid out in such a way that the mounting profile for the intermediate-position module will be subject to less deflection than the drive itself.

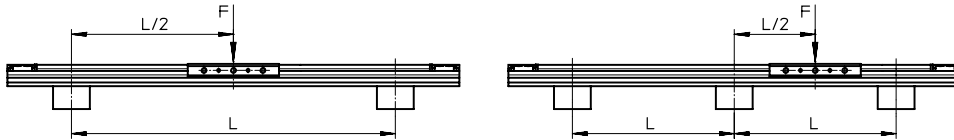

#### Deflection around the X axis

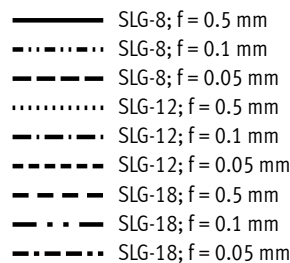
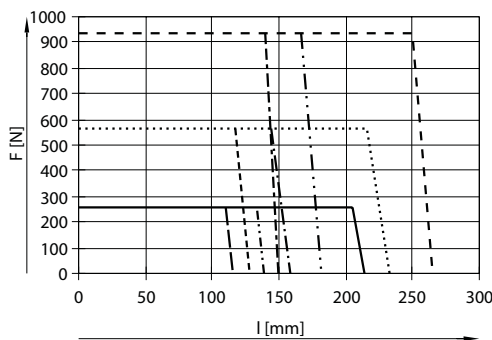
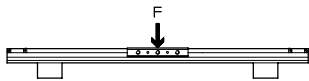

#### Deflection around the Y axis

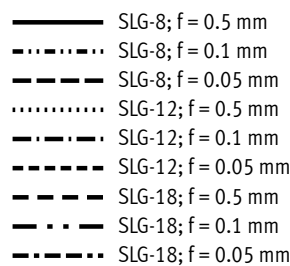
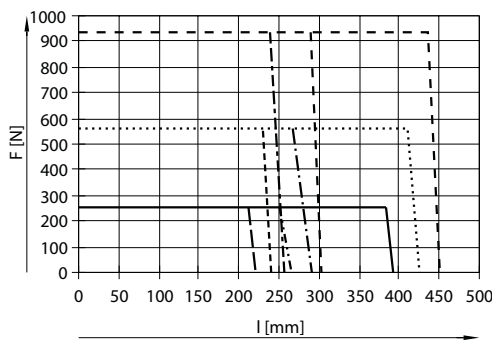
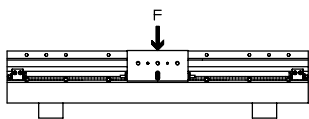

#### Flatness of the bearing surface

The contact points between the surface supporting the linear drive SLG and the linear drive should not be more than 100 mm apart or should provide support over its entire length, and should be flat to within at least 0.1 mm. The support surface for the payload on the slide should be flat to within at least 0.05 mm.

Data sheet

Minimum clearances between linear drives SLG and ferritic materials for reliable functioning of the proximity switches

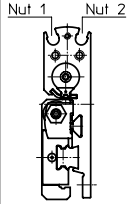
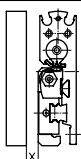
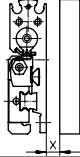
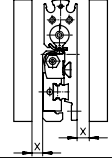
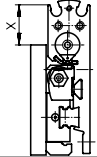
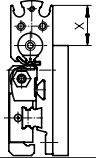
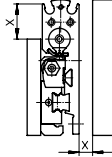
				Minimum clearances in [mm]	
		Slot	x	y	
	SLG-8	1	5	-	
		2	5	-	
	SLG-12	1	6	-	
		2	5	-	
	SLG-18	1	5	-	
		2	5	-	
	SLG-8	1	5	-	
		2	10	-	
	SLG-12	1	5	-	
		2	6	-	
	SLG-18	1	5	-	
		2	5	-	
	SLG-8	1	7	-	
		2	10	-	
	SLG-12	1	10	-	
		2	10	-	
	SLG-18	1	5	-	
		2	5	-	
	SLG-8	1	14	-	
		2	12	-	
	SLG-12	1	16	-	
		2	1	-	
	SLG-18	1	2	-	
		2	2	-	
	SLG-8	1	7	-	
		2	17	-	
	SLG-12	1	1	-	
		2	17	-	
	SLG-18	1	1	-	
		2	12	-	
	SLG-8	1	11	17	
		2	15	17	
	SLG-12	1	7	16	
		2	10	16	
	SLG-18	1	5	12	
		2	5	12	

## Data sheet

## Permissible spanner widths for the compressed air fittings

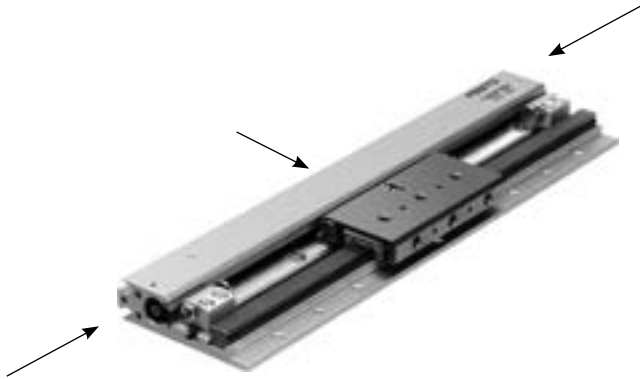

## In general

The following spanner widths can be used on the side and end face:

SLG-8:  $\approx 5.5 \dots 8$

SLG-12:  $\approx 5.5 \dots 8$

SLG-18:  $\approx 8 \dots 10$

## Restrictions on the end face

With supply ports at both ends, the fittings protrude from the top or bottom of the profile. With the supply port at one end only, the connector threads are too close to one another for the fittings.

SLG-8:  $\approx 8$

SLG-12:  $\approx 8$

SLG-18:  $\approx 10$

The following spanner widths can therefore only be used in certain conditions:

Data sheet

Dimensions

Download CAD data → [www.festo.com](http://www.festo.com)

SLG-8/-12/-18

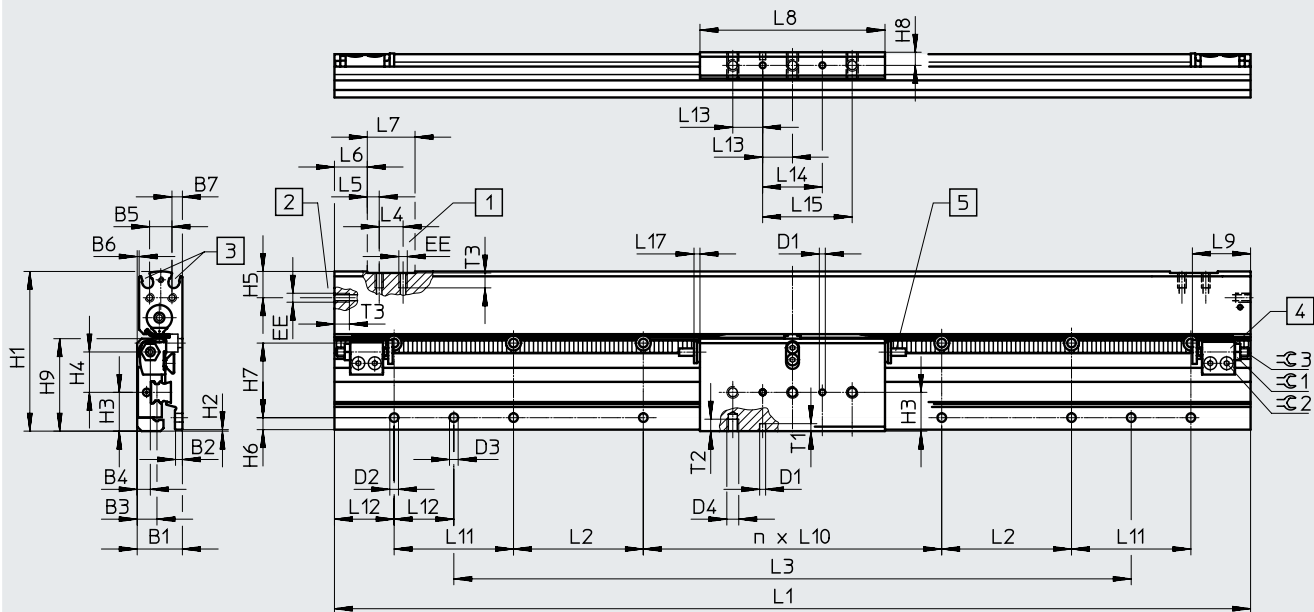

Slide SLG-18

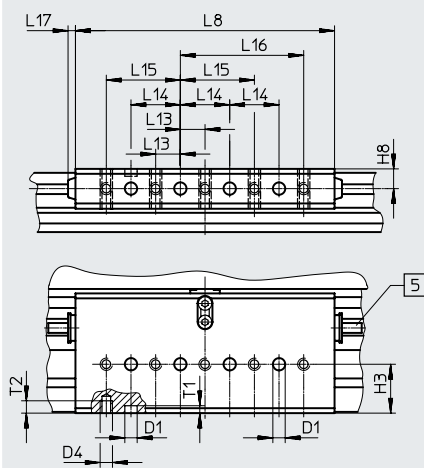

- [1] Supply port on the side
- [2] Supply port on the end face
- [3] Slot for proximity switch SME/SMT-10
- [4] Stop
- [5] Shock absorber YSR or rubber buffer (cushioning P)

Data sheet

	B1	B2	B3	B4	B5	B6	B7	D1 <sup>1)</sup> ∅ H7	D2 ∅	D3 ∅ H7	D4	EE	H1	H2
SLG-8	15	2.5	6.6	4.4	7.5	0.65	3.5	2	3.4	3	M4	M3	53.5	0.5
SLG-12	18.5	2.6	7.9	5.2	8.5	0.5	4.75	2	3.4	3	M4	M3	64.5	0.5
SLG-18	25.5	3.5	13.3	8	13.2	1.6	5.4	5	4.5	5	M5	M5	85.5	0.5

	H3	H4	H5	H6	H7	H8	H9	L2	L4	L5	L6	L7	L8	L9 min.
SLG-8	13	13.6	8.8	3.9	25	4.4	31	43.5	10	5	10	20	62	20
SLG-12	15.9	16.5	9.5	4.3	30	5.25	36.7	56.5	10	5	10	20	80	23.5
SLG-18	19.8	21.7	11.5	4.1	40	8	48.5	75.5	12	6	13	24	105	29

	L10	L11	L12	L13 ±0.1	L14 ±0.02	L15 ±0.1	L16 ±0.1	L17	T1	T2 min.	T3	≈G1	≈G2	≈G3
SLG-8	100	40	20	10	20	30	–	2	2.5	4	4.5	5.5	1.5	1.5
SLG-12	100	40	20	10	20	30	–	2	2.5	4	4.5	7	2	2
SLG-18	100	40	20	10	20	30	50	3	3	5	6	8	2.5	2.5

1) Locating hole for centring pins ZBS

	n	L1	L3
SLG-8-100	0	207	127
SLG-8-200	1	307	227
SLG-8-300	2	407	327
SLG-8-400	3	507	427
SLG-8-500	4	607	527
SLG-12-100	0	233	153
SLG-12-200	1	333	253
SLG-12-300	2	433	353
SLG-12-400	3	533	453
SLG-12-500	4	633	553
SLG-12-600	5	733	653
SLG-12-700	6	833	753
SLG-18-100	0	271	191
SLG-18-200	1	371	291
SLG-18-300	2	471	391
SLG-18-400	3	571	491
SLG-18-500	4	671	591
SLG-18-600	5	771	691
SLG-18-700	6	871	791
SLG-18-800	7	971	891
SLG-18-900	8	1071	991

## Data sheet – Intermediate-position module SLG-Z

### Function

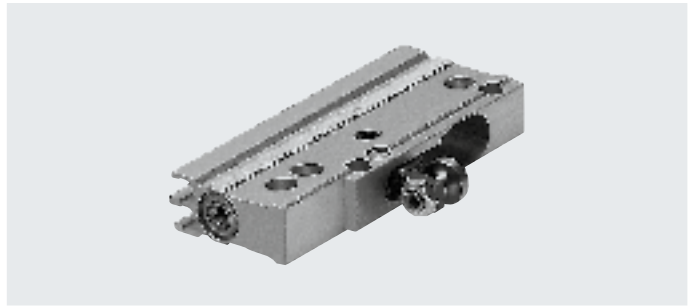
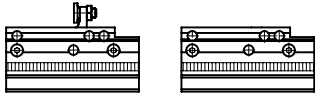

General technical data		8	12	18
Piston $\varnothing$		8	12	18
Pneumatic connection		M3		
Mode of operation		Double-acting		
Operating medium		Compressed air to ISO 8573-1:2010 [7:-:-]		
Note on operating/ pilot medium		Lubricated operation possible (in which case lubricated operation will always be required)		
Design		Rack-and-pinion rotary drive system as stop		
Precision adjustment of the intermediate position	[mm]	1.7		
Cushioning <sup>1)</sup>		→ Page 10		
Position sensing		Via proximity switch		
Type of mounting		Direct mounting		
Mounting position <sup>2)</sup>		Any		
Min. swivel time	[ms]	30		50
at 6 bar				
Max. frequency	[1/s]	16		10
at 6 bar				
Max. permissible impact velocity	[m/s]	1		1.5
Max. permissible end-stop impact force <sup>3)</sup>	[N]	320		600

- 1) The end position of the slide or another drive is not exactly defined when rubber buffers are used. Shock absorbers YSRG-... must be used for high repetition accuracy.
- 2) Shock absorbers YSRG-... must be used for high repetition accuracy as well as in non-horizontal movements. In the case of vertical mounting (stop pivoting outwards), care must be taken to ensure that foreign matter cannot get into the pivoting range of the stop.
- 3) The max. stop force must act on the centre of the buffer screw disc. Lateral forces on the buffer screw are not permissible.

Operating and environmental conditions		8	12	18
Piston $\varnothing$		8	12	18
Operating pressure	[bar]	1 ... 8		
Ambient temperature <sup>1)</sup>	[°C]	-10 ... +60		

Max. permissible energy in the intermediate position		8	12	18
Piston $\varnothing$		8	12	18
With cushioning P	[Nm]	0.1		0.6
With cushioning YSR	[Nm]	1		3



## Data sheet – Intermediate-position module SLG-Z

Weight [g]			
Piston $\varnothing$	8	12	18
Basic weight	33.5		75
Moving mass	6		14.5

**Materials**

Intermediate-position module	
[1] Housing	Hard-anodised aluminium
[2] Stop	Nickel-plated steel
[3] Buffer screw	High-alloy steel
– Seals	Polyurethane

Mounting options on the linear drive				
Piston $\varnothing$		8	12	18
Through-holes for direct mounting with screws to DIN 912	Intermediate-position module	M2.5		M3
	Cushioning mount	M4		M5
	Mounting rail	M3		M4
Centring pins	Intermediate-position module	$\varnothing$ 4H7		$\varnothing$ 5H7
	Cushioning mount	$\varnothing$ 2H7		$\varnothing$ 5H7
	Mounting rail	$\varnothing$ 3H7		$\varnothing$ 5H7

 Note

The module's symmetrical design makes it suitable for travel in both directions.

## Data sheet – Intermediate-position module SLG-Z

### Dimensions

Download CAD data → [www.festo.com](http://www.festo.com)

SLG-Z.../SLG-D.../SLG-S...

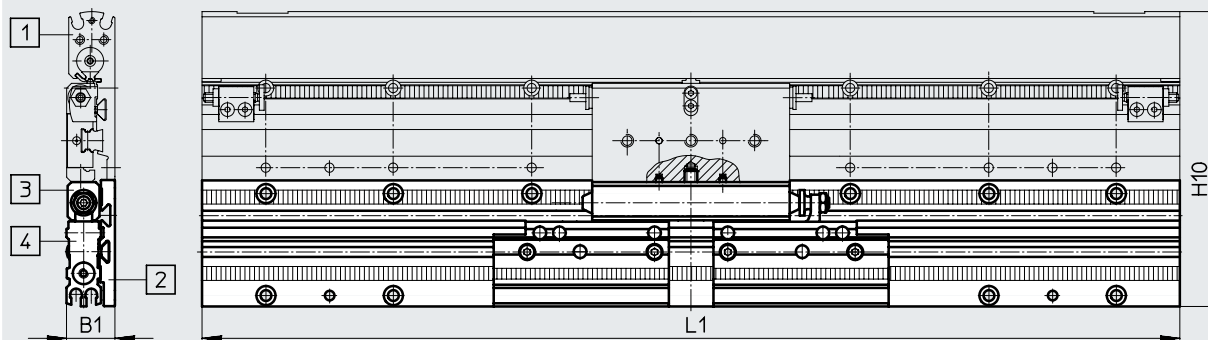

- [1] Linear drive SLG
- [2] Mounting rail SLG-S
- [3] Cushioning mount SLG-D
- [4] Intermediate position module SLG-Z

Type	B1	H10	L1
SLG-8-100	15	93.1	207
SLG-8-200			307
SLG-8-300			407
SLG-8-400			507
SLG-8-500			607
SLG-12-100	18.5	104.1	233
SLG-12-200			333
SLG-12-300			433
SLG-12-400			533
SLG-12-500			633
SLG-12-600			733
SLG-12-700			833
SLG-18-100	25.5	135.5	271
SLG-18-200			371
SLG-18-300			471
SLG-18-400			571
SLG-18-500			671
SLG-18-600			771
SLG-18-700			871
SLG-18-800			971
SLG-18-900			1071

## Data sheet – Intermediate-position module SLG-Z

### Dimensions

Download CAD data → [www.festo.com](http://www.festo.com)

The same position approached from two directions

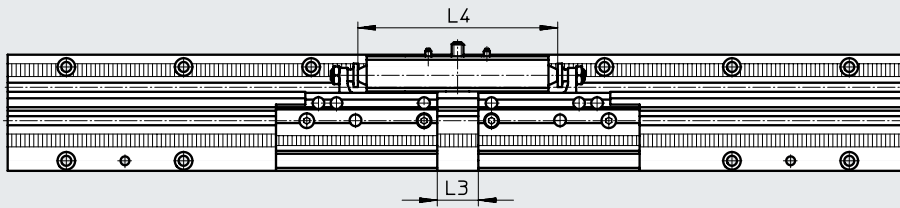

Piston $\varnothing$	L3 <sup>1)</sup>		L4
	min.	max.	
8 <sup>2)</sup>	21	27	68
12	39	45	86
18	50	56.5	111

1) Depends on the precision adjustment

2) Due to the narrowness of the space L3 only the following fittings can be used for the supply ports: 30 491 LCN-M3-PK-2-B

Two positions approached from the same direction

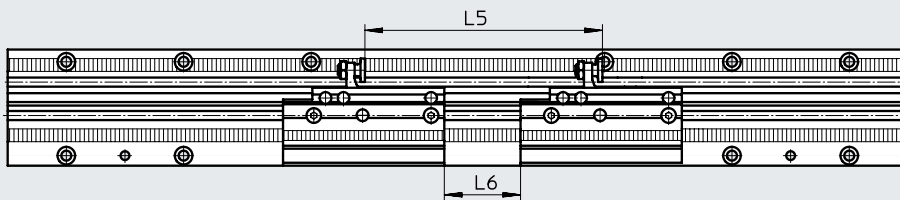

 **Note**

The space for 2 intermediate positions can be reduced to 0 mm by turning the second module by 90° in the same plane (→ page 21).

Piston $\varnothing$	L5	L6 <sup>3)</sup>
	min.	
8	90	32
12	90	
18	97	

3) The space between the modules can accommodate the following fittings for the supply port:

- 153 330 QSML-M3-3
- 153 332 QSML-M3-4
- 30 491 LCN-M3-PK-2-B
- 30 984 LCN-M3-PK-2

Space between end stop and intermediate-position module

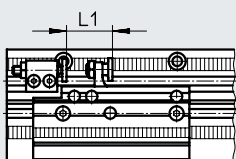

Piston $\varnothing$	L1 min.
8	20
12	
18	

## Data sheet – Intermediate-position module SLG-Z

### Dimensions

Download CAD data → [www.festo.com](http://www.festo.com)

In different mounting planes

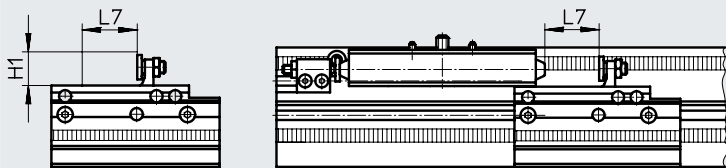

Care must be taken to ensure that each intermediate position module has sufficient space for the swivel movement in the specified range (both outwards and inwards) while it is swivelling. This corresponds to the distance (stroke) that the cushioning mount must travel from the intermediate position to ensure safe inward or outward swivelling of the stop (→ page 21).

Piston $\varnothing$	H1	L7	
		Cushioning P	Cushioning YSR
8	11	18	23
12	11	18	23
18	16	23	31

### Maximum number of intermediate-position modules on one mounting rail

The number of intermediate-position modules that can be ordered via the modular product system in combination with the linear drive SLG is restricted to max. 4. If additional intermediate positions are required, further modules can be ordered separately (→ page 23) and fitted in another mounting plane.

Piston $\varnothing$	Stroke length of the mounting rail [mm]									
	100	200	300	400	500	600	700	800	900	
8	2		3	4			-	-	-	-
12	2		3	4			4		-	-
18	2		3	4			4		4	

## Data sheet – Intermediate-position module SLG-Z

### Linear drive SLG with 2 intermediate positions

- Modules in different mounting planes
- End stops mounted on mounting rail

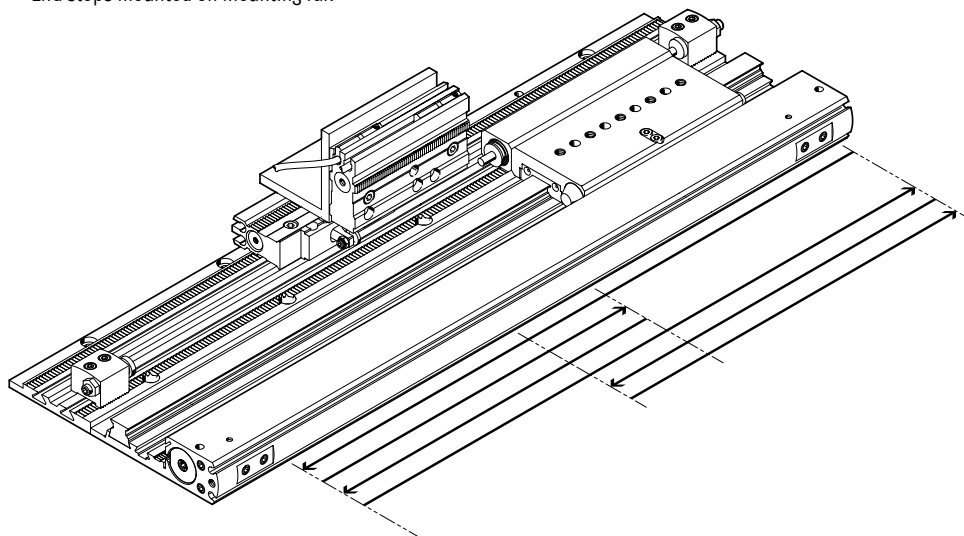

### Linear drive SLG with 3 intermediate positions

- Flat positioning
- End stops mounted on mounting rail

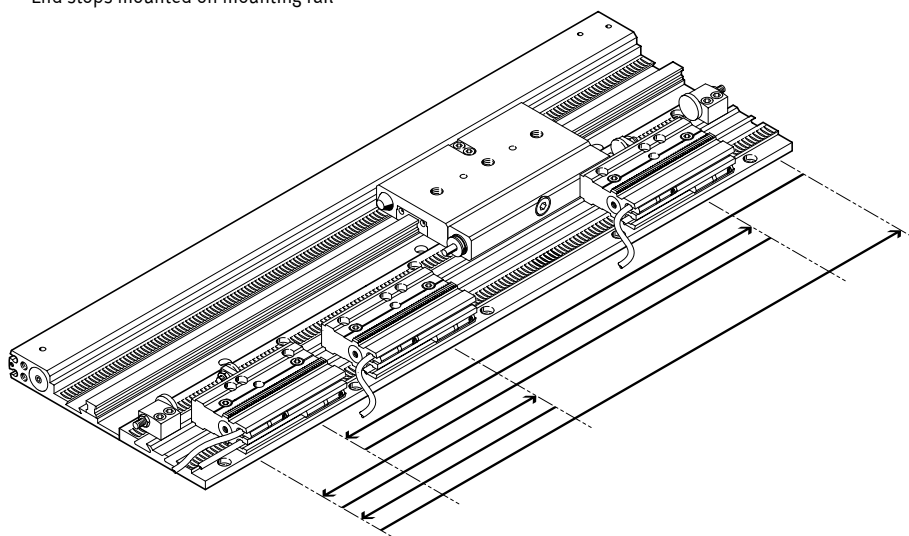

Ordering data – Modular product system

Ordering table						
Size	8	12	18	Conditions	Code	Enter code
Module no.	<b>187857</b>	<b>187855</b>	<b>187853</b>			
Function	Rodless linear drive unit				<b>SLG</b>	SLG
Size [mm]	8	12	18		-...	
Stroke [mm]	100	100	100	[1]	<b>-100</b>	
	200	200	200	[1]	<b>-200</b>	
	300	300	300	[2]	<b>-300</b>	
	400	400	400		<b>-400</b>	
	500	500	500		<b>-500</b>	
	-	600	600		<b>-600</b>	
	-	700	700		<b>-700</b>	
	-	-	800		<b>-800</b>	
	-	-	900		<b>-900</b>	
Cushioning	Elastic cushioning rings in the end positions				<b>-P</b>	
	Shock absorbers in the end positions				<b>-YSR</b>	
Position sensing	Via proximity switch				<b>-A</b>	-A
Intermediate position	1 intermediate position				<b>-Z1</b>	
	2 intermediate positions				<b>-Z2</b>	
	3 intermediate positions				<b>-Z3</b>	
	4 intermediate positions				<b>-Z4</b>	

[1] 100, 200 Max. 2 intermediate positions.

[2] 300 Max. 3 intermediate positions.

## Accessories

Intermediate-position module SLG-Z    Technical data → Seite 16

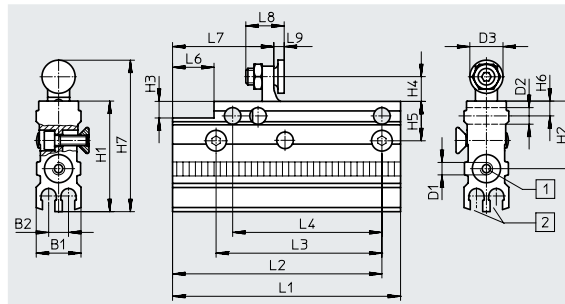

- [1] Supply ports at both ends
- [2] Slot for proximity switch SME/SMT-10

### Dimensions and ordering data

For $\varnothing$	B1	B2	D1	D2 $\varnothing$ H7	D3 $\varnothing$	H1	H2	H3	H4	H5	H6	H7	L1
8, 12	10.8	4.8	M3	4	8	26.6	16.2	4	6	9.5	3.5	36.6	55
18	15.6	4.8	M3	5	10	29.6	19.2	-	9.6	11.5	4.3	44.2	62

For $\varnothing$	L2 $\pm 0.1$	L3 $\pm 0.1$	L4 $\pm 0.02$	L6	L7	L8	L9		Weight [g]	Part no.	Type
							min.	max.			
8, 12	50.5	40	36	10	24.4	9.25	2.5	4.2	39.5	525680	SLG-Z-8/12-A
18	57.5	50	50	-	21.6	12	3.7	5.4	89.5	525681	SLG-Z-18-A

### Cushioning mount SLG-D

Material: Hard-anodised aluminium

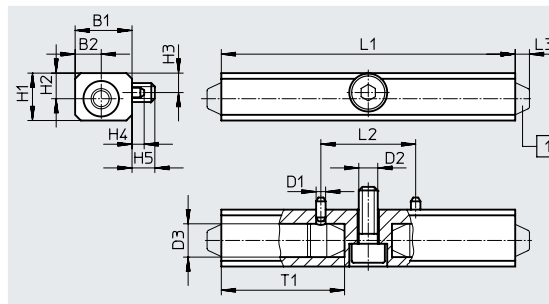

- [1] Rubber buffer or shock absorber

### Dimensions and ordering data

For $\varnothing$	B1	B2	D1 $\varnothing$ H7/h8	D2	D3 $\varnothing$	H1	H2	H3
8	11.5	5	2	M4	7.5 <sub>+0.05</sub>	10	5.4	4.1
12								-0.1
18	17	8	5	M5	10 <sub>+0.02</sub>	15	7.5	7.75

For $\varnothing$	H4	H5	L1	L2 $\pm 0.02$	L3	T1	Weight [g]	Part no.	Type
8	2.25	4.8	62	20	3	26	17/27.5 <sup>2)</sup>	525703	SLG-D-8 <sup>1)</sup>
12			80				22.5/33 <sup>2)</sup>		525704
18	2	4.7	105	60	3	43	60/104 <sup>2)</sup>	525705	SLG-D-18 <sup>1)</sup>

- 1) Shock absorber elements are not included in the scope of delivery.
- 2) With P cushioning/with YSR cushioning

Accessories

Mounting rail SLG-S

Material: Hard-anodised aluminium

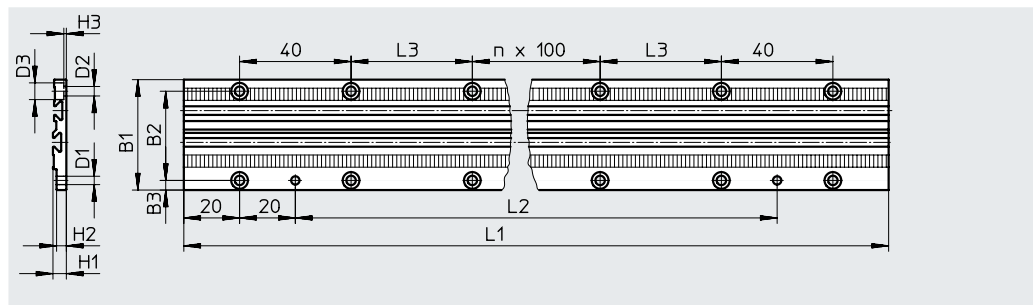

Dimensions and ordering data																		
For $\varnothing$	Stroke	B1	B2	B3	D1 $\varnothing$ H7	D2 $\varnothing$	D3 $\varnothing$	H1	H2	H3	n	L1	L2	L3	Weight [g]	Part no.	Type	
	[mm]																	
8	100	39.6	32	3.4	3	3.4	6	4.8	3.5	0.9	0	207	127	43.5	73.5	525682	SLG-S-8-100	
	200														109	525683	SLG-S-8-200	
	300														144.5	525684	SLG-S-8-300	
	400														180	525685	SLG-S-8-400	
	500														215.5	525686	SLG-S-8-500	
12	100	39.6	32	3.5	3	3.4	6	7.2	1.9	1.9	0	233	153	56.5	110.4	525687	SLG-S-12-100	
	200														157.8	525688	SLG-S-12-200	
	300														205.2	525689	SLG-S-12-300	
	400														252.6	525690	SLG-S-12-400	
	500														300	525691	SLG-S-12-500	
	600														347.4	525692	SLG-S-12-600	
	700														394.8	525693	SLG-S-12-700	
18	100	50	40	4.75	5	4.5	7.5	10.3	9	2.5	0	271	191	75.5	245.6	525694	SLG-S-18-100	
	200														336.2	525695	SLG-S-18-200	
	300														426.8	525696	SLG-S-18-300	
	400														517.4	525697	SLG-S-18-400	
	500														608	525698	SLG-S-18-500	
	600														698.6	525699	SLG-S-18-600	
	700														789.2	525700	SLG-S-18-700	
	800														879.8	525701	SLG-S-18-800	
	900														970.4	525702	SLG-S-18-900	



## Accessories

### Rubber buffer SLG



#### Ordering data

For $\varnothing$	Weight [g]	Part no.	Type
8, 12	1.5	379802	SLG-8/12
18	6	381219	SLG-18

### Shock absorber YSRG



#### Ordering data

For $\varnothing$	Weight [g]	Part no.	Type
8, 12	7	381042	YSRG-5-5-C
18	27	384581	YSRG-8-8-C

### Centring pin ZBS

Material:  
Stainless steel

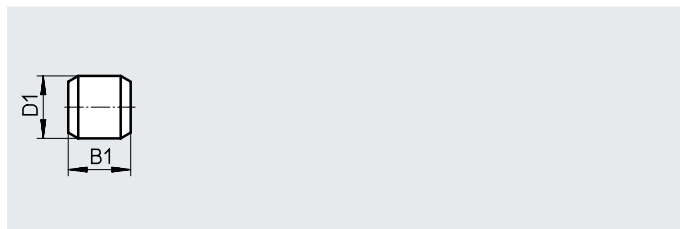
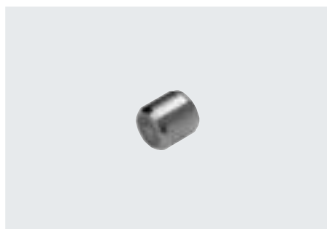

#### Dimensions and ordering data



For $\varnothing$	B1	D1	Weight	Part no.	Type	PU <sup>1)</sup>
[mm]	-0.2	$\varnothing$ h8	[g]			
8, 12	5	2	1	525273	ZBS-2	10
18	5	5	1	150928	ZBS-5	10

1) Packaging unit

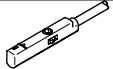
Accessories

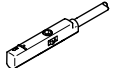
Ordering data – Proximity switch for C-slot, magneto-resistive							Data sheets → Internet: smt
	Type of mounting	Switching output	Electrical connection, outlet direction of connection	Cable length [m]	Part no.	Type	
<b>N/O contact</b>							
	Inserted in the slot from above	PNP	Cable, 3-wire, lengthwise	2.5	551373	SMT-10M-PS-24V-E-2.5-L-OE	
			Plug M8x1, 3-pin, in-line	0.3	551375	SMT-10M-PS-24V-E-0.3-L-M8D	
			Plug M8x1, 3-pin, lateral	0.3	551376	SMT-10M-PS-24V-E-0.3-Q-M8D	

Ordering data – Proximity switch for C-slot, magnetic reed							Data sheets → Internet: sme
	Type of mounting	Switching output	Electrical connection, outlet direction of connection	Cable length [m]	Part no.	Type	
<b>N/O contact</b>							
	Inserted in the slot from above	Contacting	Plug M8x1, 3-pin, in-line	0.3	551367	SME-10M-DS-24V-E-0.3-L-M8D	
			Cable, 3-wire, lengthwise	2.5	551365	SME-10M-DS-24V-E-2.5-L-OE	
			Cable, 2-wire, lengthwise	2.5	551369	SME-10M-ZS-24V-E-2.5-L-OE	

Ordering data – Connecting cables							Data sheets → Internet: nebu
	Electrical connection, left	Electrical connection, right	Cable length [m]	Part no.	Type		
	Straight socket, M8x1, 3-pin	Cable, open end, 3-wire	2.5	541333	NEBU-M8G3-K-2.5-LE3		
			5	541334	NEBU-M8G3-K-5-LE3		
	Angled socket, M8x1, 3-pin	Cable, open end, 3-wire	2.5	541338	NEBU-M8W3-K-2.5-LE3		
			5	541341	NEBU-M8W3-K-5-LE3		

Ordering data – One-way flow control valves							Data sheets → Internet: grla
	Connection Thread	For tubing O.D.	Material	Part no.	Type		
	M3	3	Metal design	175041	GRLA-M3-QS-3		
	M5	4		193138	GRLA-M5-QS-4-D		