

Parallel gripper HGPL

FESTO

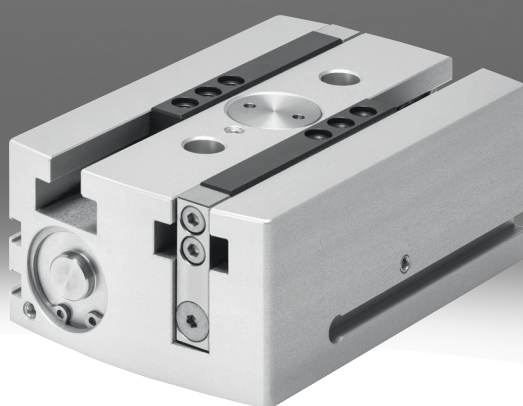

Characteristics

At a glance

[Further information → hgpl](#)

Sturdy:

- The T-slot in combination with the long guide length allows high forces and torques

Space-optimised:

- Two parallel and opposing pistons move the gripper jaws directly and without loss of force

Position sensing:

- Every position of the gripper jaws can be sensed using an analogue signal with the position transmitter SDAT

General information:

- Connections for lubrication nipple on the top and underneath the gripper
- Double-acting gripper – suitable for external and internal gripping

These grippers are not designed for the following or similar application examples:

- Machining
- Aggressive media
- Grinding dust
- Welding spatter

Engineering tools

[Further information → engineering tools](#)



Save time with engineering tools Smart Engineering for the optimal solution. Our goal is to increase your productivity. Our engineering tools play an integral part in this. They help you size your system correctly, tap into unimagined productivity reserves and generate additional productivity along the entire value chain. In every phase of your project, from the initial contact to the modernisation of your machine, you will come across a number of different tools which will be of use to you.

Gripper selection:

- This tool helps you to select the right grippers by simply entering the exact parameters for your application

Diagrams

[Further information → hgpl](#)



The diagrams shown in this document are also available online. These can be used to display precise values.

Position sensing

[A] For proximity sensor

By using proximity switches, any position can be detected.

Generation

[B] Function-optimised

Sturdy version with space-optimised design

Characteristics

Overview

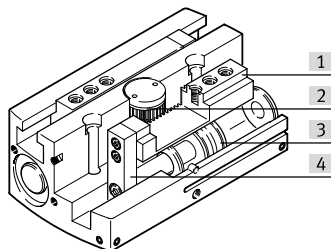

- [1] Gripper jaw
- [2] Synchronising element
- [3] Piston with magnet
- [4] Moment compensator

Type code

001	Series
HGPL	Parallel gripper, sturdy with long stroke

002	Size [mm]
14	14
25	25
40	40
63	63

003	Stroke per gripper jaw [mm]
20	20
40	40
60	60
80	80
100	100
150	150

004	Position sensing
A	For proximity sensor

005	Generation
B	Function-optimised

Datasheet

General technical data																	
Size	14				25				40				63				
Stroke per gripper jaws	20	40	60	80	20	40	60	80	20	40	60	80	100	60	100	150	
Design	Twin piston Guidance Piston gate valve T-shape Rack and pinion																
Drive system	Pneumatic																
Mode of operation	Double-acting																
Gripper force back-up	None																
Gripper function	Parallel																
Number of gripper jaws	2																
Max. mass per external gripper finger ¹⁾	80 g				250 g				420 g				940 g				
Pneumatic connection	M5													G1/8			
Repetition accuracy, gripper ²⁾	<0.03 mm																
Rotationally symmetrical	≤0.2 mm																
Max. replacement accuracy	<0.2 mm																
Max. operating frequency of gripper	<1 Hz																
Position detection	Via proximity switch																
Type of mounting	Via female thread and centring sleeve Via through-hole and centring sleeve																
Mounting position	optional																

1) Applies to unthrottled operation

2) End-position drift under constant operating conditions with 100 consecutive strokes in the direction of movement of the gripper jaws

Operating and environmental conditions								
Size	14		25		40		63	
Operating pressure	3 ... 8 bar							
Operating medium	Compressed air to ISO 8573-1:2010 [7:4:4]							
Note on operating and pilot medium	Lubricated operation possible (in which case lubricated operation will always be required)							
Ambient temperature ¹⁾	5 ... 60°C							
Corrosion resistance class CRC ²⁾	2 - Moderate corrosion stress							
Lubrication interval for guide components	5 MioCyc							

1) Note the operating range of the proximity switches

2) More information: www.festo.com/x/topic/crc

Weight – HGPL-14 ... 25								
Size	14				25			
Stroke per gripper jaws	20	40	60	80	20	40	60	80
Product weight	305 g	440 g	595 g	720 g	1,015 g	1,400 g	1,780 g	2,200 g

Weight – HGPL-40 ... 63								
Size	40					63		
Stroke per gripper jaws	20	40	60	80	100	60	100	150
Product weight	2,560 g	3,300 g	4,165 g	4,800 g	5,340 g	10,460 g	13,800 g	18,100 g

Materials								
Size	14		25		40		63	
Material housing	Smooth-anodised wrought aluminium alloy							
Material gripper jaws	Hardened steel							
Note on materials	RoHS-compliant							
LABS (PWIS) conformity	VDMA24364-B1/B2-L							

Datasheet

Measured gripping force with a lever arm of 20 mm

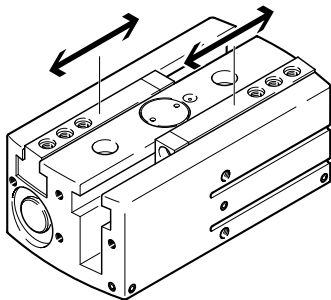

Size	14	25	40	63
Total gripping force, closing, 0.6MPa (6bar, 87 psi)	158 N	512 N	1,216 N	2,742 N
Total gripping force, opening, 0.6MPa (6bar, 87 psi)	126 N	412 N	1,038 N	2,466 N
Gripper force per gripper jaw, closing, 0.6 MPa (6 bar, 87 psi)	79 N	256 N	608 N	1,371 N
Gripper force per gripper jaw, opening, 0.6 MPa (6 bar, 87 psi)	63 N	206 N	519 N	1,233 N

Characteristic load values at the gripper jaws

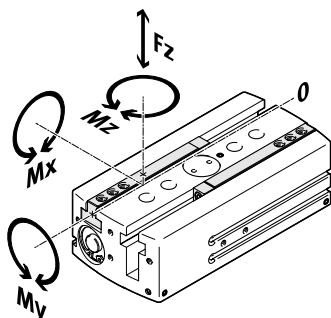

The indicated permissible forces and torques apply to a single gripper jaw. They include the lever arm, additional applied loads created by the workpiece or external gripper fingers and acceleration forces occurring during movement. The zero coordinate line (gripper jaw guide) must be taken into account when calculating torques.

Size	14	25	40	63
Max. force on gripper jaw F_z static	500 N	1,500 N	2,500 N	9,000 N
Max. torque at gripper M_x static	35 Nm	100 Nm	125 Nm	300 Nm
Max. torque at gripper M_y static	35 Nm	60 Nm	80 Nm	200 Nm
Max. torque at gripper M_z static	35 Nm	70 Nm	100 Nm	250 Nm

Gripping force F_H per gripper jaw as a function of operating pressure and lever arm x – External gripping (closing)

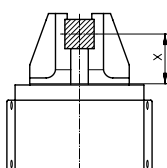

The gripping forces as a function of operating pressure and lever arm can be determined from the following graphs.

The gripping torque is not constant across the opening angle.

Sizing software for gripper selection → www.festo.com

Datasheet

Gripping force FH per gripper jaw as a function of operating pressure and lever arm x – External gripping (closing), double-acting – HGPL-14

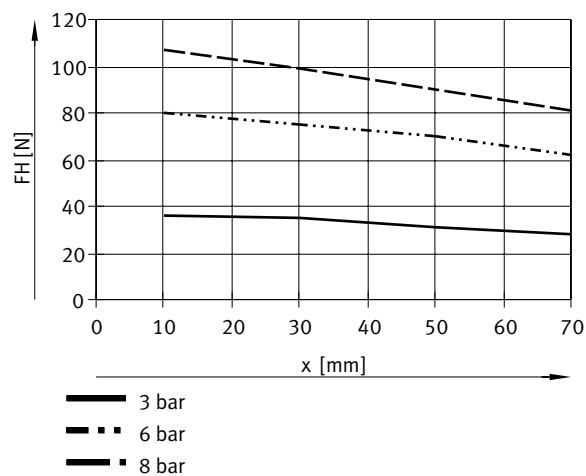

Gripping force FH per gripper jaw as a function of operating pressure and lever arm x – External gripping (closing), double-acting – HGPL-25

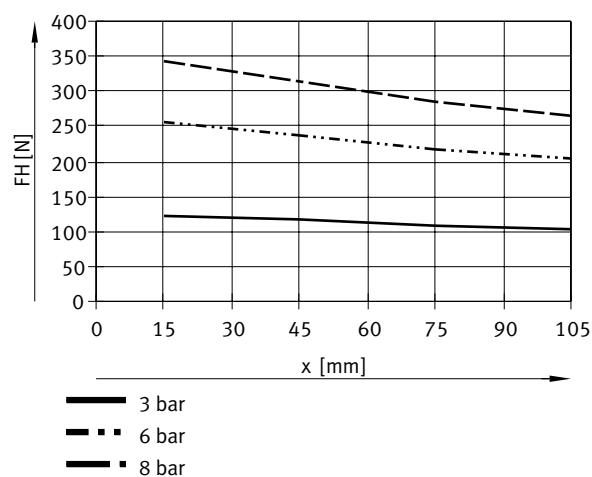

Gripping force FH per gripper jaw as a function of operating pressure and lever arm x – External gripping (closing), double-acting – HGPL-40

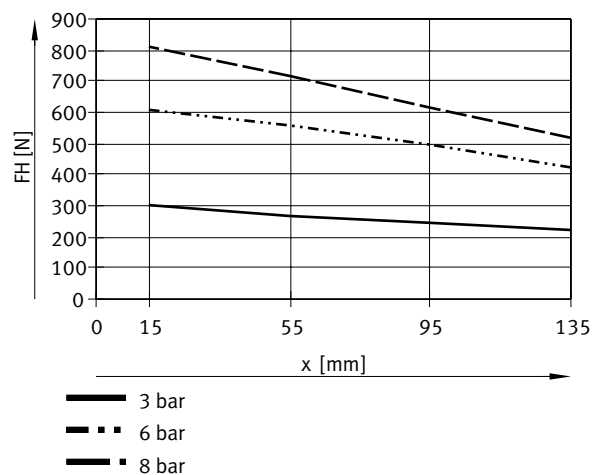

Datasheet

Gripping force FH per gripper jaw as a function of operating pressure and lever arm x – External gripping (closing), double-acting – HGPL-63

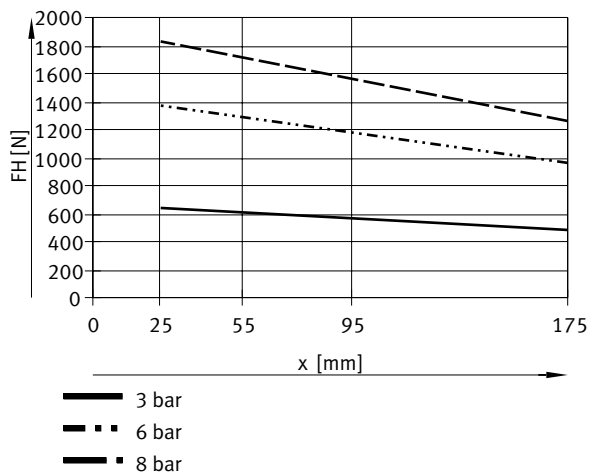

Gripping force FH per gripper jaw as a function of operating pressure and lever arm x – Internal gripping (opening)

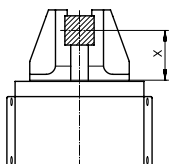

The gripping forces as a function of operating pressure and lever arm can be determined from the following graphs.
The gripping torque is not constant across the opening angle.

Sizing software for gripper selection → www.festo.com

Gripping force FH per gripper jaw as a function of operating pressure and lever arm x – Internal gripping (opening), double-acting – HGPL-14

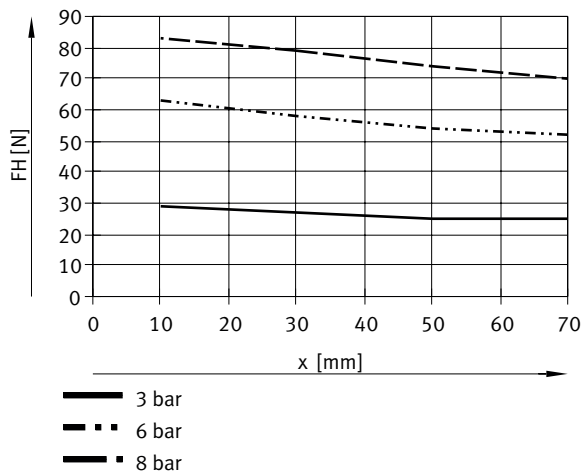

Datasheet

Gripping force FH per gripper jaw as a function of operating pressure and lever arm x – Internal gripping (opening), double-acting – HGPL-25

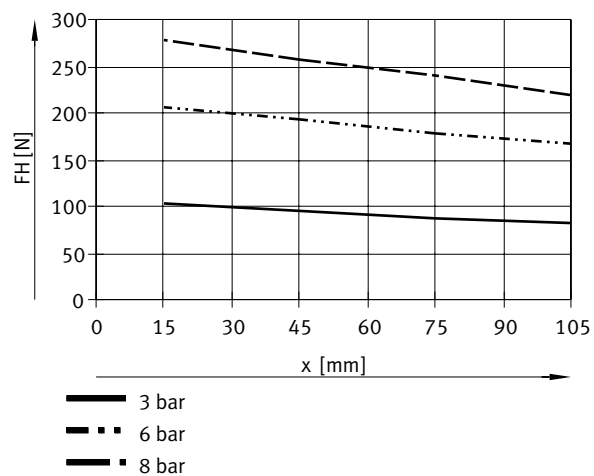

Gripping force FH per gripper jaw as a function of operating pressure and lever arm x – Internal gripping (opening), double-acting – HGPL-40

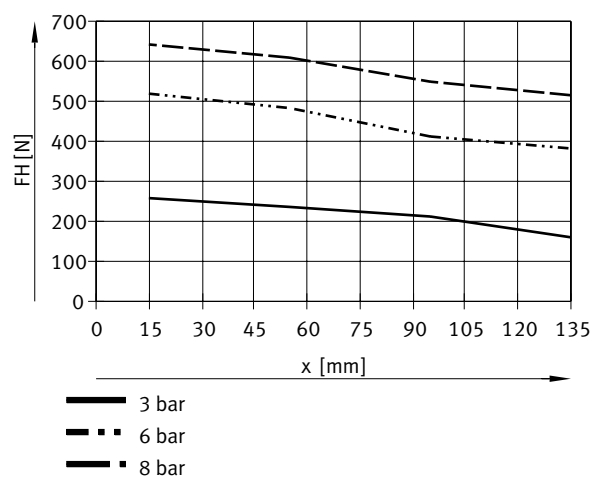

Gripping force FH per gripper jaw as a function of operating pressure and lever arm x – Internal gripping (opening), double-acting – HGPL-63

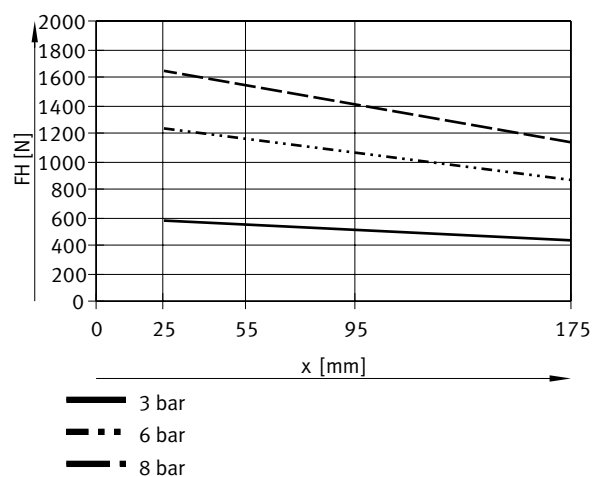

Datasheet

Gripping force FH per gripper jaw at 0.6 MPa (6 bar, 87 psi) as a function of lever arm x and eccentricity a and b

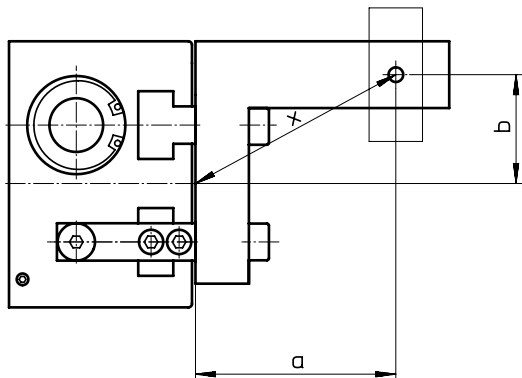

Gripping force FH per gripper jaw at 0.6 MPa (6 bar, 87 psi) as a function of lever arm x and eccentricity a and b

$$x = \sqrt{a^2 + b^2} = \sqrt{45^2 + 40^2} = 60 \text{ mm}$$

The formula (on the left) must be used to calculate the lever arm x with eccentric gripping. The gripping force FH can then be read from the graphs using the calculated value x.

Calculation example:

Assuming:

Distance a = 45 mm

Distance b = 40 mm

To be determined:

The gripping force at 6 bar with an HGPL-25, used as an external gripper.

Gripping force FH per gripper jaw at 0.6 MPa (6 bar, 87 psi) as a function of lever arm x and eccentricity a and b

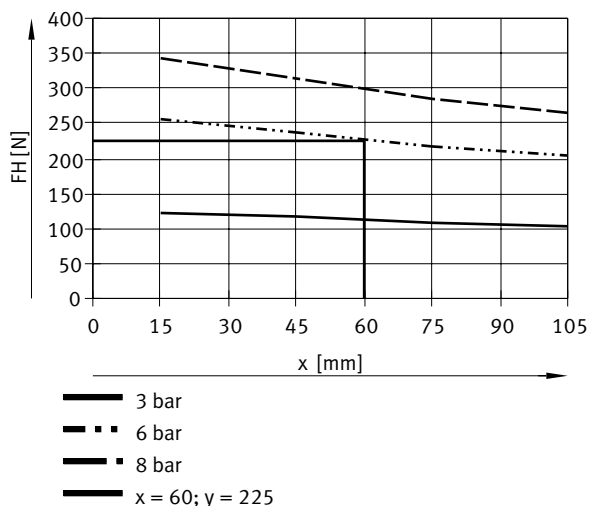

The graph gives a value of FH = 225 N for the gripping force.

Datasheet

Mass moments of inertia

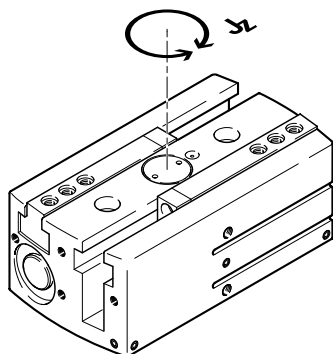

Mass moment of inertia of the parallel grippers in relation to the central axis, without external gripper fingers, with no load.

Mass moments of inertia – HGPL-14 ... 25

Size	14				25			
Stroke per gripper jaws	20	40	60	80	20	40	60	80
Mass moment of inertia	1.4 kgcm ²	6.69 kgcm ²	11.43 kgcm ²	21.93 kgcm ²	11.98 kgcm ²	18.88 kgcm ²	39.95 kgcm ²	78.7 kgcm ²

Mass moments of inertia – HGPL-40 ... 63

Size	40					63			
Stroke per gripper jaws	20	40	60	80	100	60	100	150	
Mass moment of inertia	27.6 kgcm ²	66.83 kgcm ²	118.3 kgcm ²	198.87 kgcm ²	318.25 kgcm ²	470.07 kgcm ²	1,018.17 kgcm ²	2,247.54 kgcm ²	

Gripper jaw backlash

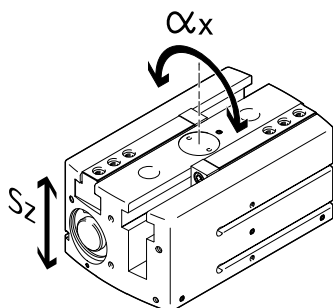

The plain-bearing guide used in the grippers means that there is backlash between the gripper jaws and the housing. The values listed in the table apply in new condition.

Size	14	25	40	63
Max. gripper jaw backlash S_z ¹⁾	<0.05 mm			
Max. angular gripper jaw backlash α_x, α_y ²⁾	<0.2 deg			

1) The values only apply when the gripper is open.

2) The values only apply when the gripper is open.

Datasheet

Opening and closing times – HGPL-14 ... 25

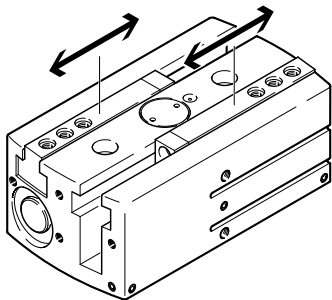

The indicated opening and closing times [ms] were measured at room temperature at an operating pressure of 0.6 MPa (6 bar, 87 psi) with a horizontally mounted gripper without additional gripper fingers.

The grippers must be throttled for larger loads [g]. Opening and closing times must then be adjusted accordingly.

Size	14				25			
Stroke per gripper jaws	20	40	60	80	20	40	60	80
Min. opening time at 0.6 MPa (6 bar, 87 psi)	120 ms	171 ms	270 ms	286 ms	170 ms	225 ms	370 ms	423 ms
Min. closing time at 0.6 MPa (6 bar, 87 psi)	110 ms	163 ms	230 ms	270 ms	150 ms	230 ms	370 ms	418 ms

Opening and closing times – HGPL-40 ... 63

Size	40					63		
Stroke per gripper jaws	20	40	60	80	100	60	100	150
Min. opening time at 0.6 MPa (6 bar, 87 psi)	190 ms	238 ms	430 ms	414 ms	620 ms	410 ms	650 ms	1,020 ms
Min. closing time at 0.6 MPa (6 bar, 87 psi)	180 ms	205 ms	430 ms	438 ms	690 ms	330 ms	600 ms	850 ms

Dimensions

Dimensions – Parallel gripper HGPL

Download CAD data → www.festo.com

HGPL - 14 / 25 - . . .

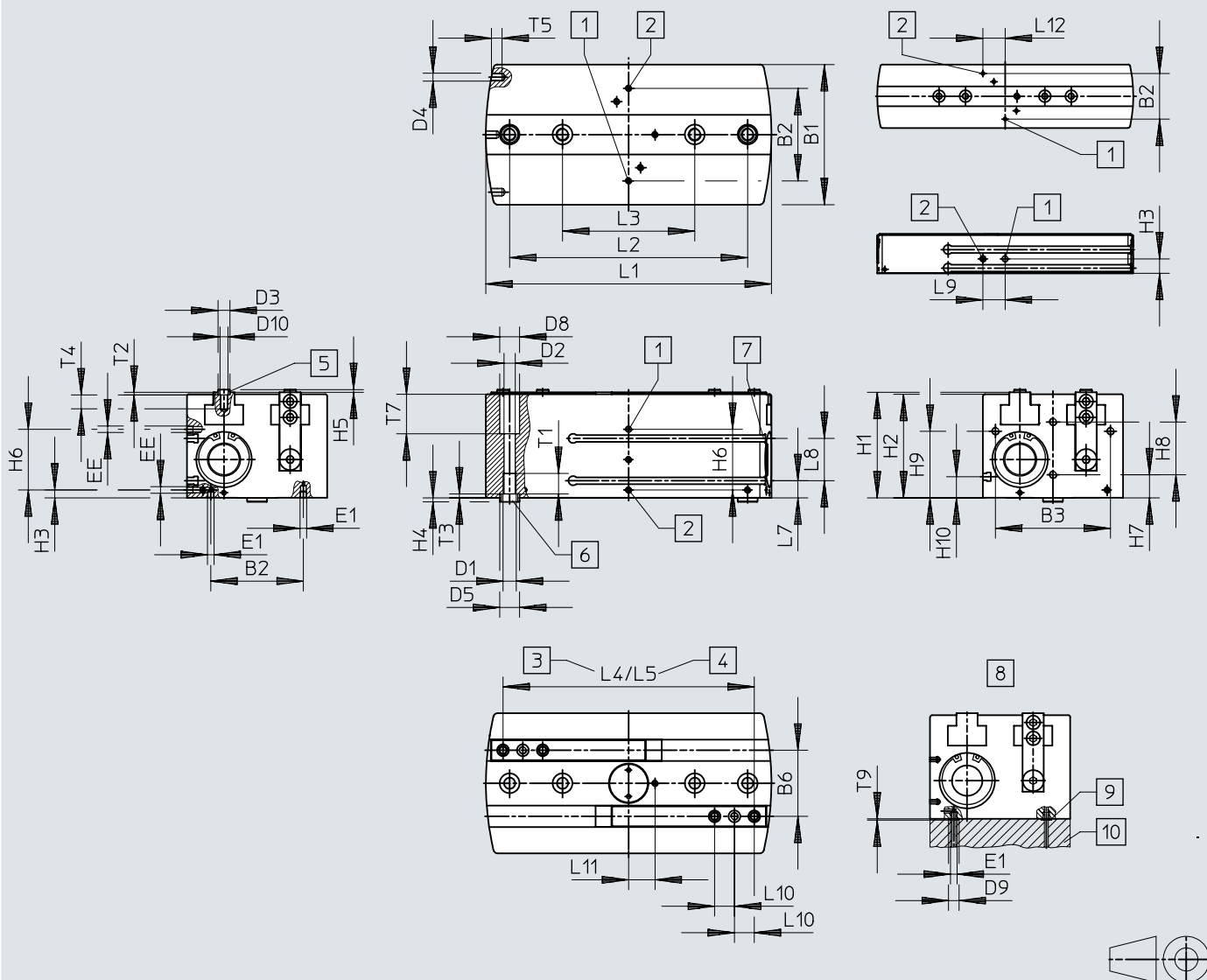

- [1] Compressed air connection opening, either on the side or underneath (delivery status: connection underneath sealed)
- [2] Compressed air connection closing, either at the side or underneath (delivery status: connection underneath sealed)
- [3] Gripper jaws open
- [4] Gripper jaws closed
- [5] Centring sleeves ZBH (4 included in the scope of delivery)
- [6] Centring sleeves ZBH (2 included in the scope of delivery)
- [7] Slot for proximity switch
- [8] Compressed air supply underneath
- [9] O-ring for parallel gripper HGPL-14: Ø 3x1.5 / HGPL-25: Ø 5x1.5 / HGPL-40: Ø 5x1.5 / HGPL-63: Ø 12x1.5
- [10] Bearing surface

Dimensions

	B1 ±0,05	B2	B3	B6 ±0,01	D1	D2 ∅ +0,1	D3 ∅ H8	D4	D5 ∅ H8	D8 ∅ H13	D9 ∅	D10	EE	E1
HGPL-14	48	34,5±0,1	40±0,2	22	M5	4,2	5	M3	9	7,4	6	M3	M5	M3
HGPL-25	80	60±0,2	65±0,1	38	M6	5,1	7	M5	9	10	8	M5	M5	M5
HGPL-40	106	70±0,2	87±0,1	50	M10	8,5	9	M6	15	15	8	M6	M5	M5
HGPL-63	154	116±0,2	130±0,1	78	M12	10,4	15	M8	15	16,5	15	M10	G1/8	G1/8

	H1 ±0,05	H2 ±0,05	H3 ±0,1	H4 -0,3	H5 -0,3	H6	H7 ±0,1	H8 ±0,1	H9 ±0,1	H10 ±0,1	L1 ±0,05	L2 ¹⁾	L3 ¹⁾	L4 ±0,5
HGPL-14-20	30	29	11,2	1,9	1,2	-	10	12	24,4	4	73,6	36	-	62
HGPL-14-40											113,6	60	-	102
HGPL-14-60											153,6	100	60	142
HGPL-14-80											193,6	100	60	182
HGPL-25-20	50	49	18	1,9	1,4	-	18	20	30	11	86	60	-	64
HGPL-25-40											126	60	-	104
HGPL-25-60											166	100	60	144
HGPL-25-80											206	100	60	184
HGPL-40-20	80	78,5	6	2,9	1,9	46±0,2	17,5	40	50,5	16	96	66	-	70
HGPL-40-40											136	100	-	110
HGPL-40-60											176	100	-	150
HGPL-40-80											216	180	100	190
HGPL-40-100											256	200	100	230
HGPL-63-60	121,5	120	14	2,9	2,9	60±0,1	30	58	75	28,5	190,8	100	-	160
HGPL-63-100											270	200	100	240
HGPL-63-150											370	300	100	340

	L5 ±0,5	L7 ±0,1	L8 ±0,1	L9	L10 ¹⁾	L11	L12 ±0,1	T1 max.	T2 +0,1	T3 +0,1	T4 min.	T5 min.	T7 +0,1	T9
HGPL-14-20	22	4,2	14	16,8±0,2	8	7,5±0,1	16,8	12,5	1,3	2,1	5,5	6,5	10	1
HGPL-14-40						9±0,1								
HGPL-14-60						9±0,1								
HGPL-14-80						9±0,1								
HGPL-25-20	24	11	14	20±0,1	10	17±0,2	20	12,5	1,6	2,1	8,5	7,5	17	1
HGPL-25-40														
HGPL-25-60														
HGPL-25-80														
HGPL-40-20	30	13	32	-	15	20±0,1	-	15,5	2,1	3,1	10,5	8	30	1
HGPL-40-40						12,6								
HGPL-40-60						10,5								
HGPL-40-80						10,5								
HGPL-40-100						10,5								
HGPL-63-60	40	28,5	30	-	22	28±0,1	-	18	3,1	3,1	17,5	12	45	1
HGPL-63-100														
HGPL-63-150														

1) Tolerance for centring hole ±0.02 mm Tolerance for thread ±0.1 mm

Dimensions

Dimensions – Mounting bracket DHAS-MA-B6-60

Download CAD data → www.festo.com

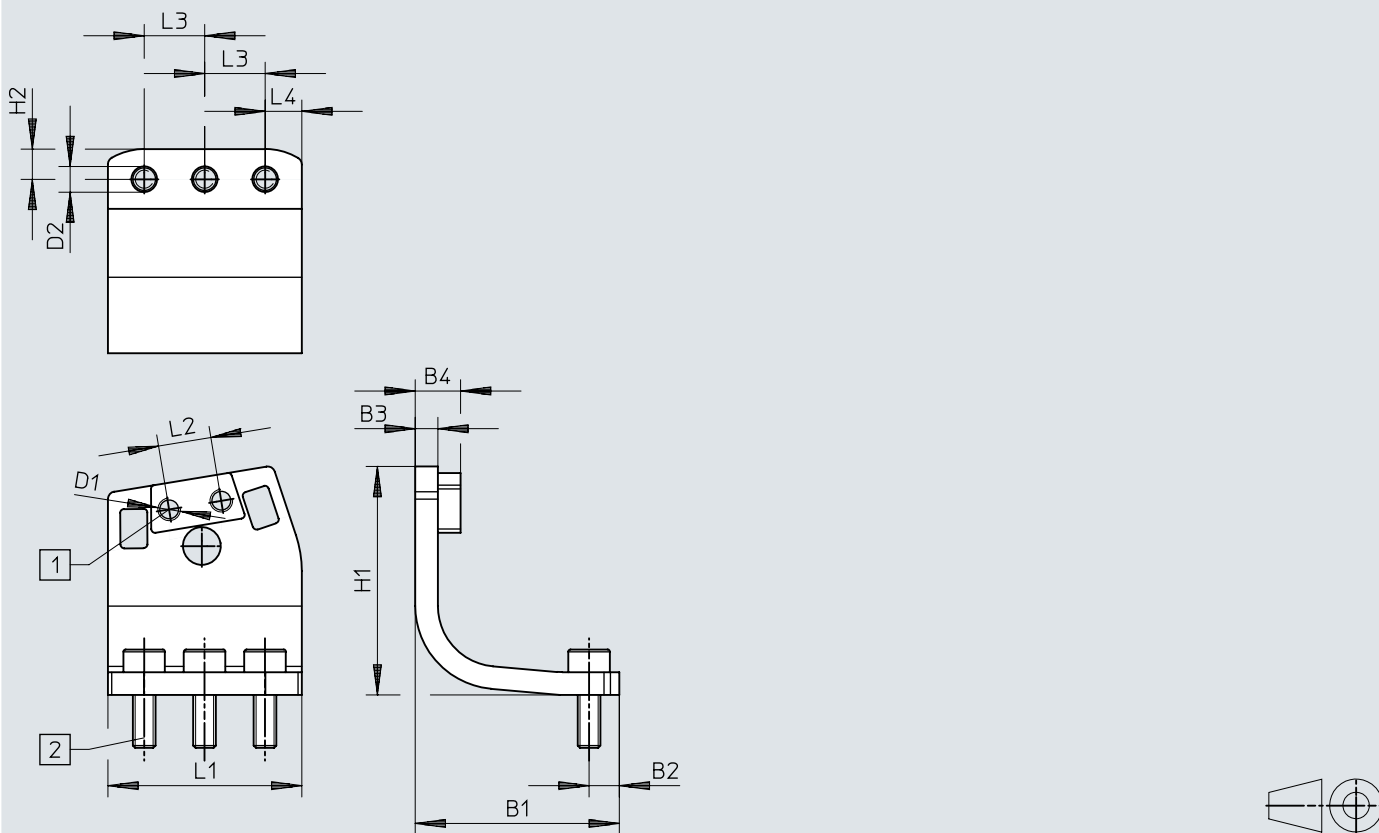

[1] Mounting thread

[2] Screw M3x8-8.8 (included in the scope of delivery)

	B1	B2	B3	B4	D1	D2	H1	H2	L1	L2	L3	L4
			±0,2	±0,1		∅				±0,1	±0,1	
DHAS-MA-B6-60	27	4	3	6	M3	3,4	30,3	4	25,7	7	8	4,85

Dimensions

Dimensions – Mounting bracket DHAS-MA-B6-80

Download CAD data → www.festo.com

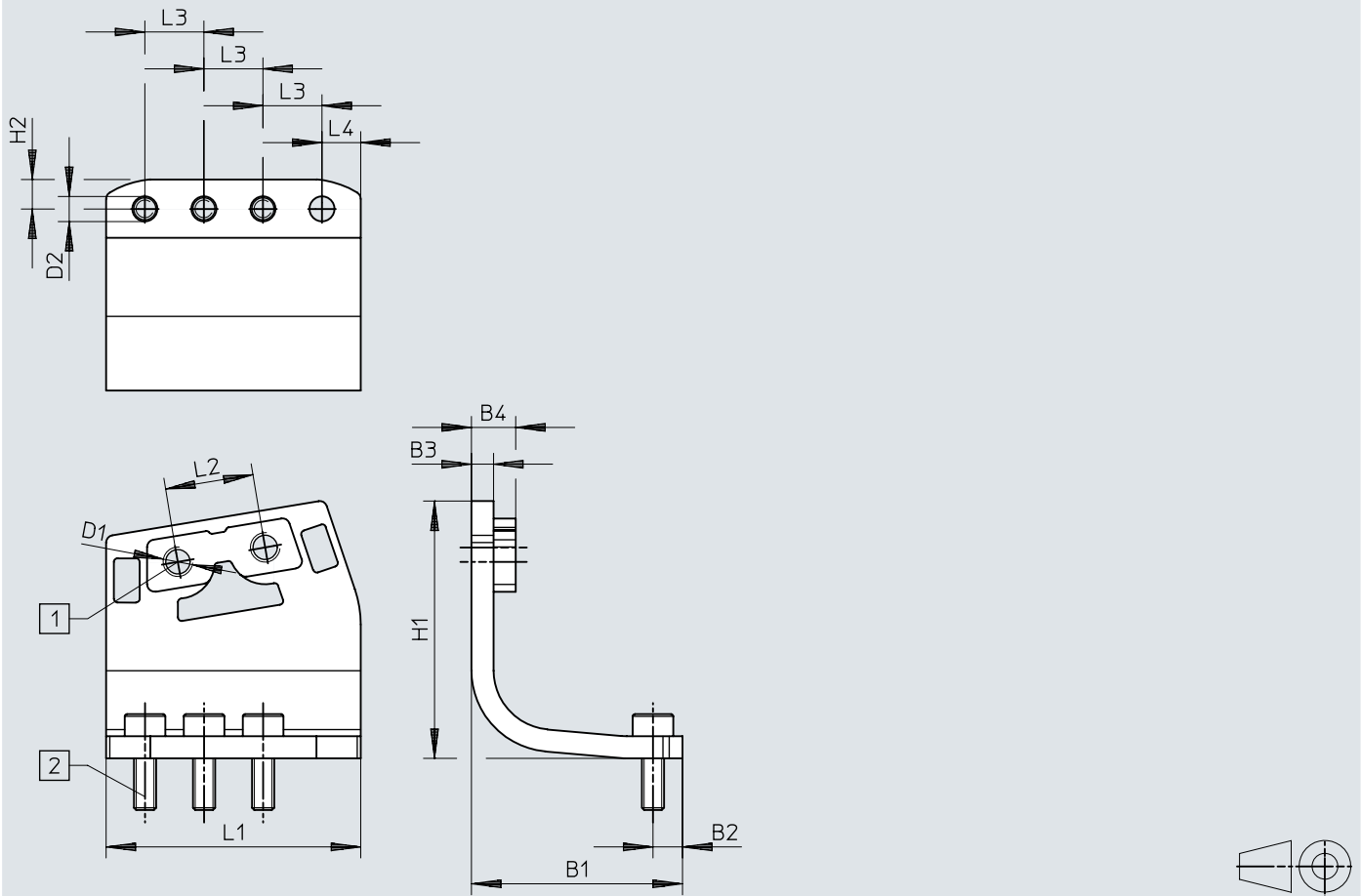

- [1] Mounting thread
- [2] Screw M3x8-8.8 (included in the scope of delivery)

	B1	B2	B3	B4	D1	D2	H1	H2	L1	L2	L3	L4
			±0,2	±0,1		∅				±0,1	±0,1	
DHAS-MA-B6-80	28,6	4	3	6	M4	3,3	35	4	34,5	12	8	5,25

Dimensions

Dimensions – Mounting bracket DHAS-MA-B6-120

Download CAD data → www.festo.com

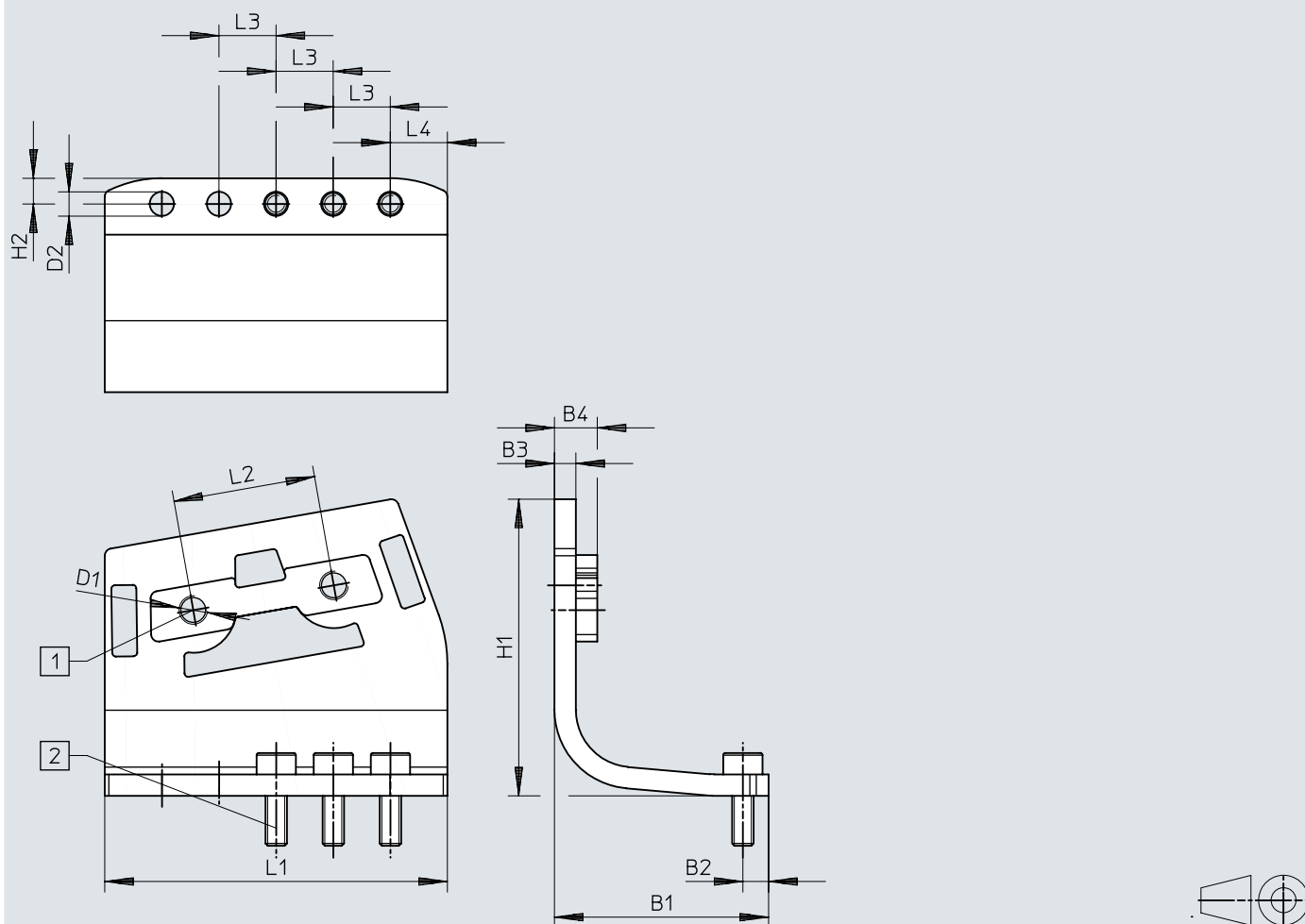

- [1] Mounting thread
- [2] Screw M3x8-8.8 (included in the scope of delivery)

	B1	B2	B3	B4	D1	D2	H1	H2	L1	L2	L3	L4
			±0,2	±0,1		∅				±0,1	±0,1	
DHAS-MA-B6-120	30	3,6	3	6	M4	3,4	41,7	3,6	48	20	8	7,9

Dimensions

Dimensions – Adaptive gripper finger DHAS-GF

Download CAD data → www.festo.com

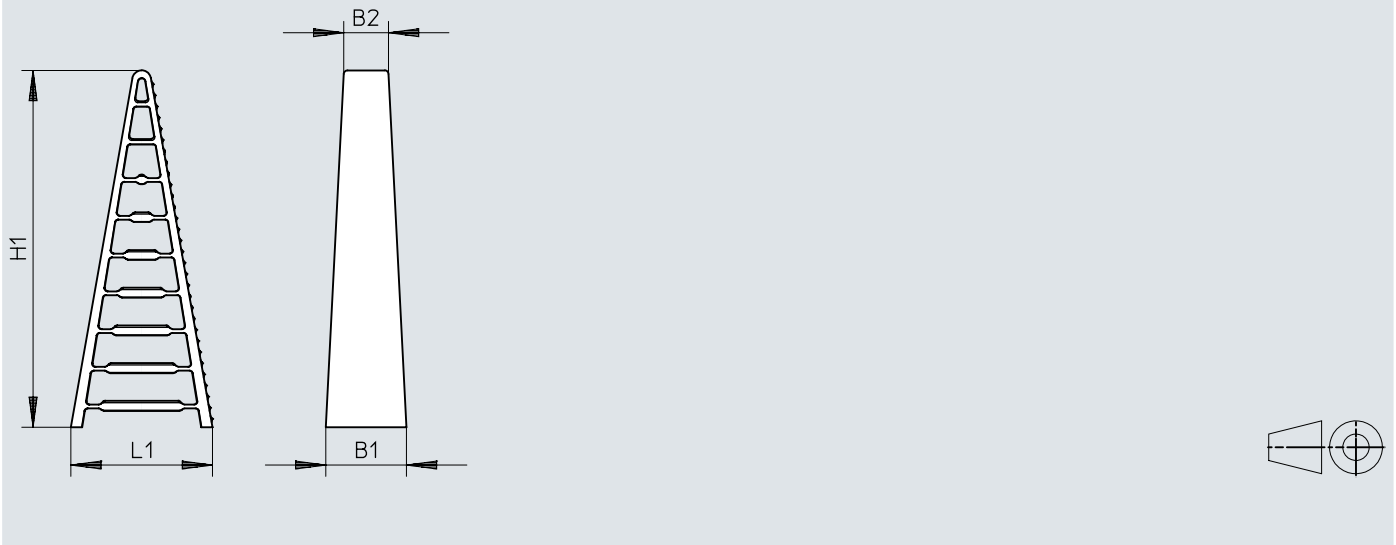

	B1	B2	H1	L1
DHAS-GF-60-U-BU	18	11,8	61,5	26
DHAS-GF-80-U-BU	21,3	11,8	94,5	37,5
DHAS-GF-120-U-BU	25	11,8	134,5	50

Dimensions

Dimensions – Mounting kit DHAS-ME-H9-60/80

Download CAD data → www.festo.com

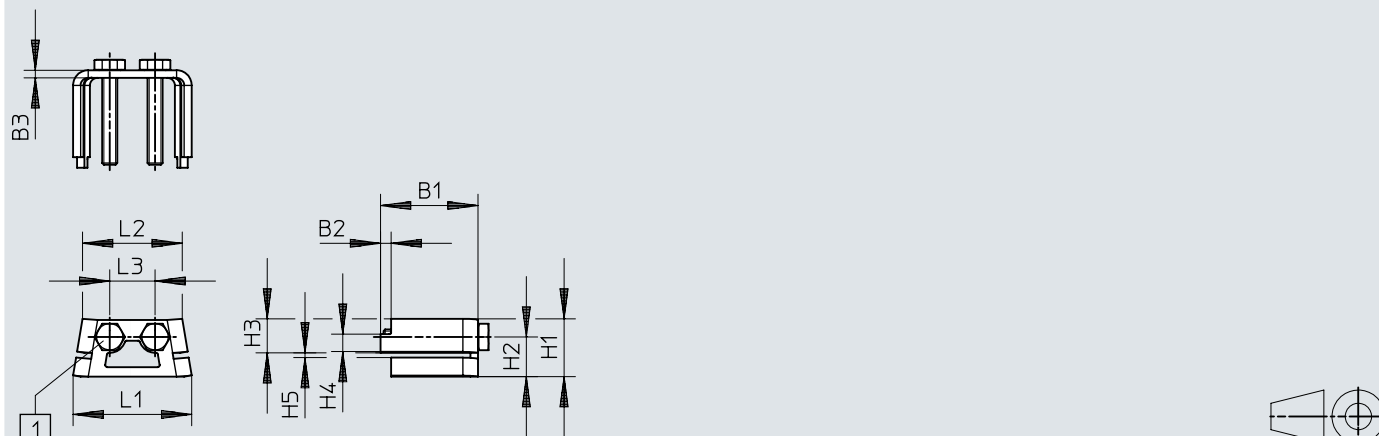

[1] DHAS-ME-H9-60: M3x22-A2-70 ISO 4017 screw / DHAS-ME-H9-80: M4x25-A2-700 ISO 4017 screw (included in the scope of delivery)

	B1	B2	B3	H1	H2	H3	H4	H5	L1	L2	L3
			±0,1					±0,1			±0,1
DHAS-ME-H9-60	22,8	2,8	2	10,3	6,7	7	3,6	1,3	20,7	17,4	7
DHAS-ME-H9-80	25,8	2,8	2	15,3	10,5	9	4,6	1,3	31,4	26,4	12

Dimensions

Dimensions – Mounting kit DHAS-ME-H9-120

Download CAD data → www.festo.com

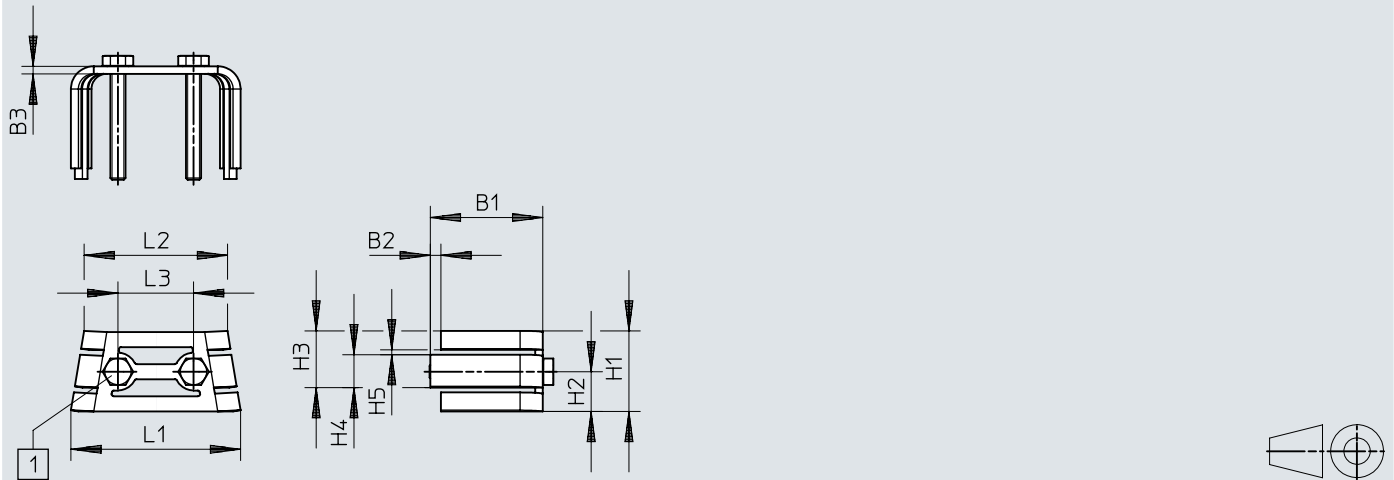

[1] DHAS-ME-H9-120: screw M4x30-A2-70 ISO 4017 (included in the scope of delivery)

	B1	B2	B3	H1	H2	H3	H4	H5	L1	L2	L3
			±0,1					±0,1			±0,1
DHAS-ME-H9-120	29,8	2,8	2	21,3	10,5	15	8,7	1,3	44,9	38	20

Dimensions

Dimensions – Stroke reducing kit HGPL-HR

Download CAD data → www.festo.com

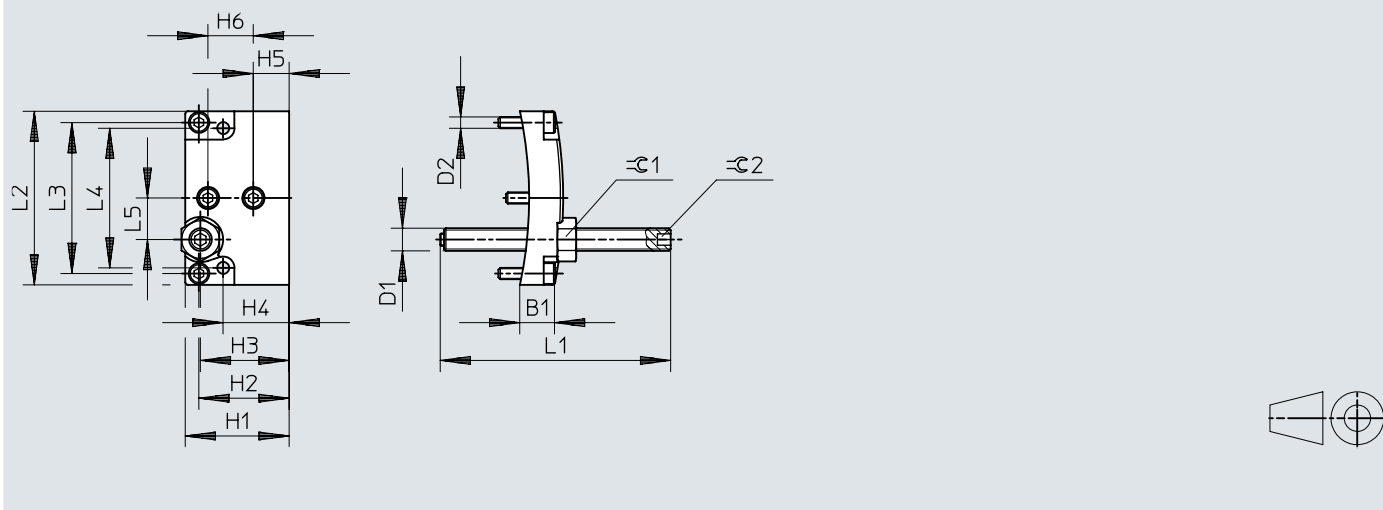

	B1	D1	D2	H1	H2	H3	H4	H5	H6	L1	L2	L3	L4	L5	≙C1	≙C2
	±0,1			±0,1	±0,1	±0,1	±0,1	±0,1	±0,1	±0,1	±0,1	±0,1	±0,1	±0,1		
HGPL-HR-14	9	M6	M3	27,5	23,9	23,5	17,5	9,5	12	61	46	40	37	11	10	3
HGPL-HR-25	12	M8	M5	47,5	–	37,5	29,5	17,5	20	61	77	–	65	19	13	4
HGPL-HR-40	18	M12	M6	77	–	63	50	17	40	61	103	–	87	25	19	6
HGPL-HR-63	19	M14	M8	118,5	–	94,5	74,5	29,5	58	81	151	–	130	39	22	6

Dimensions

Dimensions – Gripper jaw blank BUB-HGPL

Download CAD data → www.festo.com

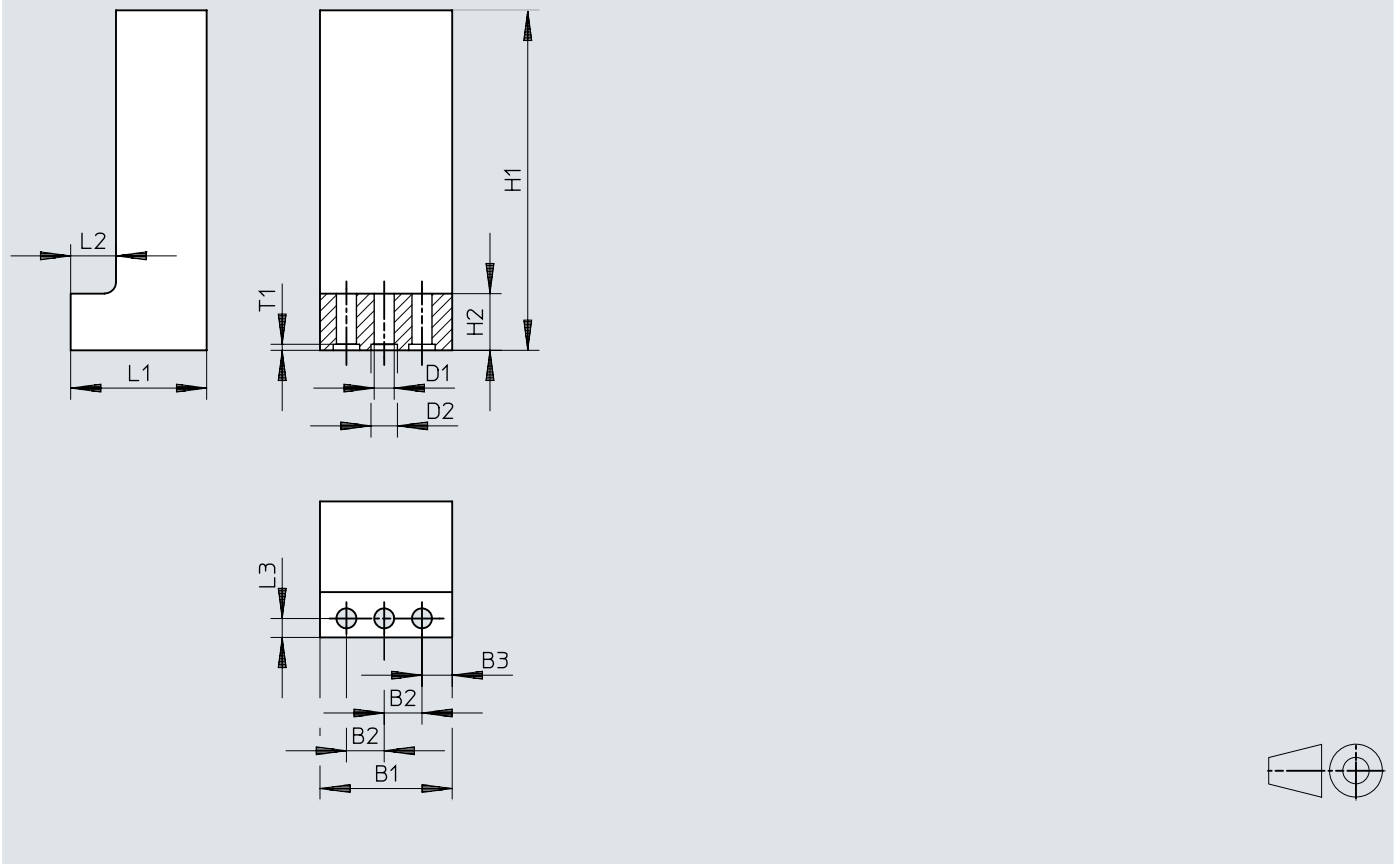

	B1	B2	B3	D1 ∅ +0,1	D2 ∅ H8	H1 ±0,1	H2	L1 ±0,1	L2 +0,1	L3 +0,1	T1 +0,1
BUB-HGPL-14	25	8	4	3,2	5	80	11	20,5	8	3,3	1,3
BUB-HGPL-25	35	10	8	5,3	7	120	15	36	12	5	1,6
BUB-HGPL-40	50	15	10	6,4	9	150	18	49,5	16,5	8	2,1
BUB-HGPL-63	68	22	12	10,5	15	200	20	77	27	12	3,1

Ordering data

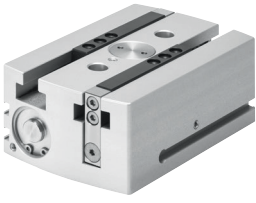
Parallel gripper HGPL						
	Size	Stroke per gripper jaws	Mode of operation	Product weight	Part no.	Type
	14	20 mm	Double-acting	305 g	3361479	HGPL-14-20-A-B
		40 mm		440 g	3361480	HGPL-14-40-A-B
		60 mm		595 g	3361481	HGPL-14-60-A-B
		80 mm		720 g	3361482	HGPL-14-80-A-B
	25	20 mm		1,015 g	3361483	HGPL-25-20-A-B
		40 mm		1,400 g	3361484	HGPL-25-40-A-B
		60 mm		1,780 g	3361485	HGPL-25-60-A-B
		80 mm		2,200 g	3361486	HGPL-25-80-A-B
	40	20 mm		2,560 g	3361487	HGPL-40-20-A-B
		40 mm		3,300 g	3361488	HGPL-40-40-A-B
		60 mm		4,165 g	3361489	HGPL-40-60-A-B
		80 mm		4,800 g	3361490	HGPL-40-80-A-B
	63	100 mm		5,340 g	3361491	HGPL-40-100-A-B
		60 mm		10,460 g	3361492	HGPL-63-60-A-B
		100 mm		13,800 g	3361493	HGPL-63-100-A-B
				150 mm	18,100 g	3361494

Peripherals

Peripherals overview

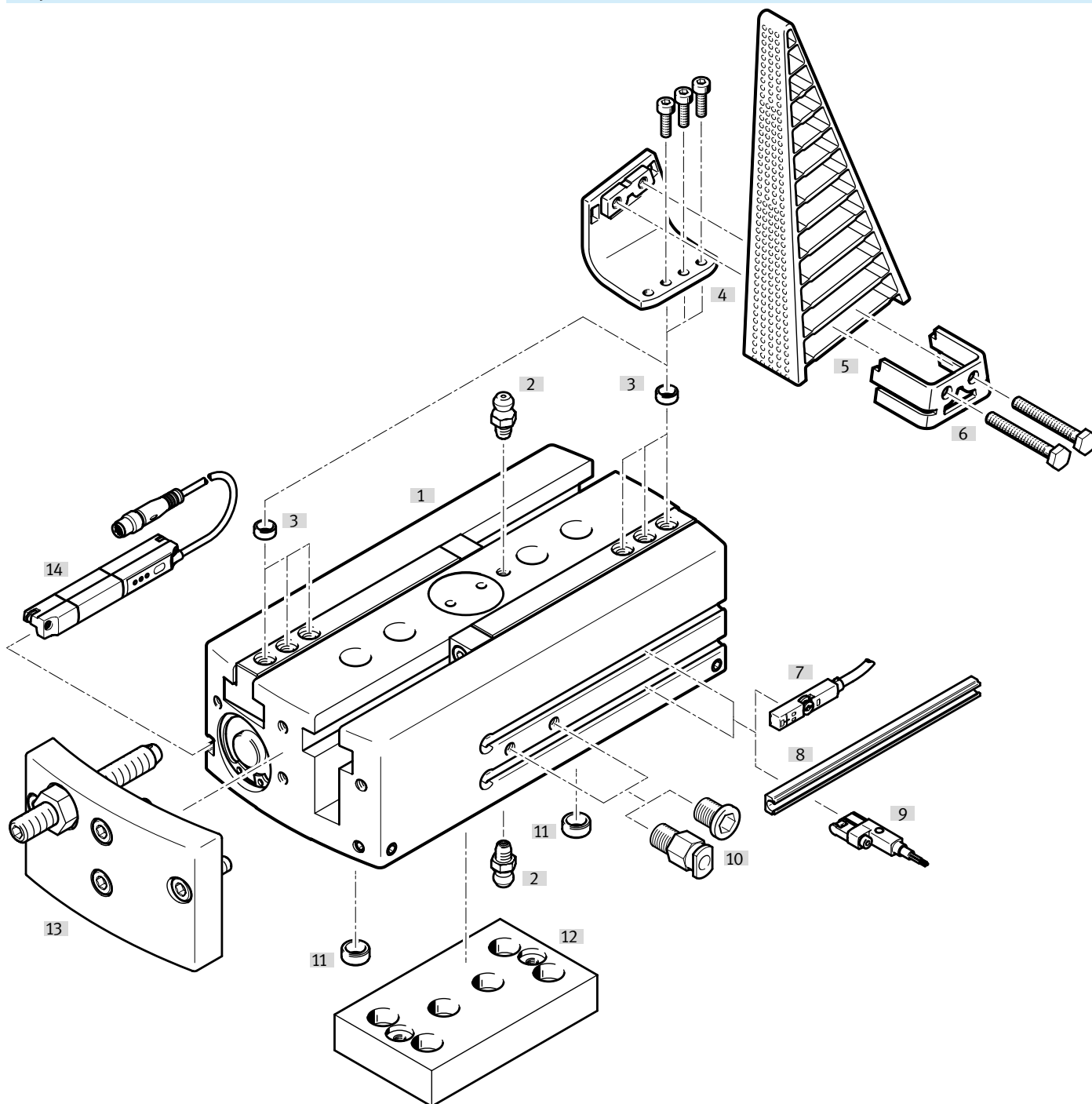

Accessories		→ Link
Type/order code	Description	
[1] Parallel gripper HGPL	Double-acting drive, heavy-duty with long stroke	hgpl
[2] Lubrication nipple	<ul style="list-style-type: none"> For relubricating the guide 1 included in the scope of delivery 	hgpl
[3] Centring sleeve ZBH	<ul style="list-style-type: none"> For centring the gripper jaw blanks/gripper fingers on the gripper jaws 4 included in the scope of delivery 	27
[4] Mounting bracket DHAS-MA	<ul style="list-style-type: none"> For mounting the adaptive gripper finger DHAS-GF on the gripper Available for size 14 	26
[5] Adaptive gripper finger DHAS-GF	<ul style="list-style-type: none"> For flexible gripping Available in the sizes 60, 80, 120 The mounting components DHAS-MA and DHAS-ME are also required to attach the gripper fingers to the gripper 	26

Peripherals

Accessories			→ Link
Type/order code	Description		
[6] Mounting kit DHAS-ME	For mounting the adaptive gripper finger DHAS-GF on the mounting bracket DHAS-MA		26
[7] Proximity switch SME/SMT-8	For sensing the piston position in the end positions		28
[8] Sensor rail DASP	By gluing this into the sensor slot, proximity switches SME/SMT-10 can be used		28
[9] Proximity switch SME/SMT-10	For sensing the piston position in the end positions		29
[10] Push-in fitting QS	For connecting tubing with standard O.D		qs
[10] Blanking plug B	For sealing the compressed air ports when using the compressed air ports at the front		27
[11] Centring sleeve ZBH	<ul style="list-style-type: none"> • For centring the gripper during mounting • 2 included in the scope of delivery 		27
[12] Adapter kit DHAA, HAPG, HMSV, HMVA	Drive/gripper connections		adapter
[13] Stroke reducing kit HGPL-HR	For reducing the opening stroke		26
[14] Position transmitter SDAT/SMAT	<ul style="list-style-type: none"> • For sensing the piston position at any point • The position transmitter must only be inserted into this slot 		30
[15] Gripper jaw blank BUB-HGPL	Blanks specially matched to the gripper jaws for custom manufacturing of gripper fingers		27

Accessories

Mounting kit DHAS-MA

	Description	Material adapter bracket	Product weight	Part no.	Type
	For size 14	High-alloy stainless steel	23 g	3920696	DHAS-MA-B6-60
			38 g	3899099	DHAS-MA-B6-80
			59 g	3889257	DHAS-MA-B6-120

Adaptive gripper finger DHAS-GF

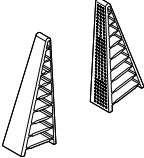
	Description ¹⁾	Material clamp jaws	Product weight	Part no.	Type
	For DHAS-MA-B6-60	TPE-U(PU)	7 g	3998967	DHAS-GF-60-U-BU
	For DHAS-MA-B6-80		13 g	3998964	DHAS-GF-80-U-BU
	For DHAS-MA-B6-120		29 g	3998959	DHAS-GF-120-U-BU

1) The mounting components DHAS-MA and DHAS-ME are also required to attach the gripper fingers to the gripper.

Mounting kit DHAS-ME

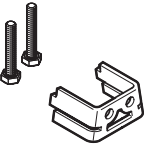
	Description	Material adapter	Product weight	Part no.	Type
	For DHAS-GF-60-U-BU	High-alloy stainless steel	7 g	4464306	DHAS-ME-H9-60
	For DHAS-GF-80-U-BU		13 g	4463570	DHAS-ME-H9-80
	For DHAS-GF-120-U-BU		23 g	4461433	DHAS-ME-H9-120







Stroke reducing kit HGPL-HR

	Description	Part no.	Type
	For size 14	539092	HGPL-HR-14
	For size 25	539093	HGPL-HR-25
	For size 40	539094	HGPL-HR-40
	For size 63	567831	HGPL-HR-63

Gripper jaw blank BUB-HGPL

	Description	Material unmachined part	Product weight per gripper jaw	Part no.	Type
	For size 14	Wrought aluminium alloy	75 g	537316	BUB-HGPL-14

Accessories

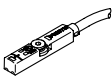
Gripper jaw blank BUB-HGPL						
	Description	Material unmachined part	Product weight per gripper jaw	Part no.	Type	
	For size 25	Wrought aluminium alloy	295 g	537317	BUB-HGPL-25	
	For size 40		720 g	537318	BUB-HGPL-40	
	For size 63		1,960 g	567830	BUB-HGPL-63	
Centring sleeve ZBH-5						
	Description	Material sleeve	Size of pack	Product weight	Part no.	Type
	For size 14	Steel	10	1 g	8146543	ZBH-5-B
Centring sleeve ZBH-7						
	Description	Material sleeve	Size of pack	Product weight	Part no.	Type
	For size 25	Steel	10	1 g	8146544	ZBH-7-B
Centring sleeve ZBH-9						
	Description	Material sleeve	Size of pack	Product weight	Part no.	Type
	For sizes 14, 25, 40	Steel	10	2 g	8137184	ZBH-9-B
Centring sleeve ZBH-15						
	Description	Material sleeve	Size of pack	Product weight	Part no.	Type
	For sizes 40, 63	High-alloy stainless steel	10	3 g	191409	ZBH-15
Blanking plug B-M5						
	Description	Material blanking plug	Size of pack	Product weight	Part no.	Type
	For sizes 14, 25, 40	Galvanised steel	10	1 g	★ 174308	B-M5-B
Blanking plug B-1/8						
	Description	Material blanking plug	Size of pack	Product weight	Part no.	Type
	For size 63	Galvanised steel	10	7 g	★ 3568	B-1/8
Proximity switch SMT-8M for T-slot, magneto-resistive						
	Type of mounting	Switching output	Electrical connection	Cable length	Part no.	Type
	Screw-clamped, Insertable in the slot from above	3-wire NPN N/O contact	Open end	2.5 m	★ 574338	SMT-8M-A-NS-24V-E-2,5-OE

Accessories

Proximity switch SMT-8M for T-slot, magneto-resistive

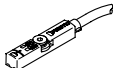
	Type of mounting	Switching output	Electrical connection	Cable length	Part no.	Type
	Screw-clamped, Insertable in the slot from above	3-wire NPN N/O contact	Plug M8, A-coded	0.3 m	★ 574339	SMT-8M-A-NS-24V-E-0,3-M8D
		3-wire PNP N/C contact	Open end	7.5 m	★ 574340	SMT-8M-A-PO-24V-E-7,5-OE
		3-wire PNP N/O contact	Plug M8, A-coded Plug M12, A-coded	2.5 m	★ 574335	SMT-8M-A-PS-24V-E-2,5-OE
				0.3 m	★ 574334	SMT-8M-A-PS-24V-E-0,3-M8D
				★ 574337	SMT-8M-A-PS-24V-E-0,3-M12	

Proximity switch SME-8 for T-slot, magnetic reed

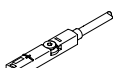
	Type of mounting	Switching output	Electrical connection	Cable length	Part no.	Type
	Screw-clamped, Insertable in the slot from above	3-wire N/O contact	Open end	2.5 m	543862	SME-8M-DS-24V-K-2,5-OE
			5 m	543863	SME-8M-DS-24V-K-5,0-OE	
		2-wire PNP N/O contact	Plug M8, A-coded	0.3 m	543861	SME-8M-DS-24V-K-0,3-M8D
			Open end	2.5 m	543872	SME-8M-ZS-24V-K-2,5-OE
	Clamped in T-slot, Insertable in the slot lengthwise	None	Plug M8, A-coded	0.3 m	150855	SME-8-K-LED-24
			N/C contact, 3-wire	Open end	7.5 m	150857
				160251	SME-8-O-K-LED-24	

Proximity switch SMT-8G for T-slot, magneto-resistive

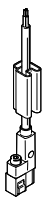
	Type of mounting	Switching output	Electrical connection	Cable length	Part no.	Type
	Clamped in T-slot, Insertable in the slot lengthwise	3-wire PNP N/O contact	Open end	2.5 m	547859	SMT-8G-PS-24V-E-2,5-Q-OE
			Plug M8, A-coded	0.3 m	547860	SMT-8G-PS-24V-E-0,3-Q-M8D

Sensor rail DASP – for proximity switch SME/SMT-10

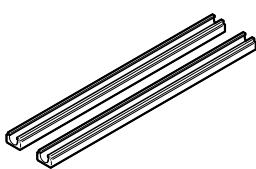
	Description	Material adhesive	Part no.	Type
	For gripper stroke max. 60 mm, to be glued into the slot	Construction adhesive	3528767	DASP-B6-60-C-SR
	For gripper stroke max. 80 mm, to be glued into the slot		3528768	DASP-B6-80-C-SR

Proximity switch SMT-10M for round slot, magneto-resistive

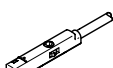
	Type of mounting	Switching output	Electrical connection	Cable length	Part no.	Type
	Screw-clamped, Insertable in the slot from above	3-wire PNP N/O contact	Open end	2.5 m	551374	SMT-10M-PS-24V-E-2,5-Q-OE
				★ 551373	SMT-10M-PS-24V-E-2,5-L-OE	
			Plug M8, A-coded	0.3 m	★ 551375	SMT-10M-PS-24V-E-0,3-L-M8D
				★ 551376	SMT-10M-PS-24V-E-0,3-Q-M8D	

Accessories

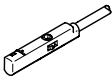
Proximity switch SME-10M for round slot, magnetic reed						
	Type of mounting	Switching output	Electrical connection	Cable length	Part no.	Type
	Screw-clamped, Insertable in the slot from above	3-wire N/O contact	Open end	2.5 m	551365	SME-10M-DS-24V-E-2,5-L-OE
					551366	SME-10M-DS-24V-E-2,5-Q-OE
			Plug M8, A-coded	0.3 m	551367	SME-10M-DS-24V-E-0,3-L-M8D
					551368	SME-10M-DS-24V-E-0,3-Q-M8D

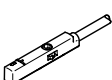
Proximity switch SME-10-KL-... for round slot, magnetic reed						
	Type of mounting	Digital switching output	Electrical connection	Cable length	Part no.	Type
	Clamped in C-slot, Insertable in the slot lengthwise	3-wire N/O contact	Open end	0.3 m	173212	SME-10-SL-LED-24
				2.5 m	173210	SME-10-KL-LED-24

Proximity switch SMT-10G for round slot, magneto-resistive						
	Type of mounting	Switching output	Electrical connection	Cable length	Part no.	Type
	Clamped in C-slot, Insertable in the slot lengthwise	3-wire PNP N/O contact	Open end	2.5 m	547862	SMT-10G-PS-24V-E-2,5Q-OE
			Plug M8, A-coded	0.3 m	547863	SMT-10G-PS-24V-E-0,3Q-M8D

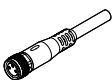
Connecting cables NEBU, straight, M8 connection						
	Electrical connection 1, connector system	Electrical connection 2, connector system	Electrical connection 2, number of connections/cores	Cable length	Part no.	Type
	M8x1, A-coded, to EN 61076-2-104	Open end	3	2.5 m	541333	NEBU-M8G3-K-2.5-LE3
				5 m	541334	NEBU-M8G3-K-5-LE3

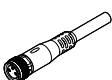
Connecting cables NEBU, straight, M12 connection						
	Electrical connection 1, connector system	Electrical connection 2, connector system	Electrical connection 2, number of connections/cores	Cable length	Part no.	Type
	M12x1, A-coded to EN 61076-2-101	Open end	3	2.5 m	541363	NEBU-M12G5-K-2.5-LE3
				5 m	541364	NEBU-M12G5-K-5-LE3

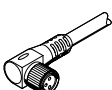
Connecting cables NEBU, angled, M8 connection						
	Electrical connection 1, connector system	Electrical connection 2, connector system	Electrical connection 2, number of connections/cores	Cable length	Part no.	Type
	M8x1, A-coded, to EN 61076-2-104	Open end	3	2.5 m	541338	NEBU-M8W3-K-2.5-LE3

Accessories

Connecting cables NEBU, angled, M8 connection

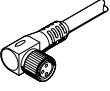
	Electrical connection 1, connector system	Electrical connection 2, connector system	Electrical connection 2, number of connections/cores	Cable length	Part no.	Type
	M8x1, A-coded, to EN 61076-2-104	Open end	3	5 m	541341	NEBU-M8W3-K-5-LE3

Connecting cables NEBU, angled, M12 connection

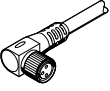
	Electrical connection 1, connector system	Electrical connection 2, connector system	Electrical connection 2, number of connections/cores	Cable length	Part no.	Type
	M12x1, A-coded to EN 61076-2-101	Open end	3	2.5 m	541367	NEBU-M12W5-K-2.5-LE3
				5 m	541370	NEBU-M12W5-K-5-LE3

Position transmitter SDAT for T-slot, M8 plug, A-coded

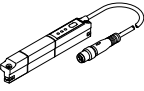
	Sensing range	Analogue output	Electrical connection 1, number of connections/cores	Cable length	Part no.	Type
	0 ... 50.000 mm	4 - 20 mA	4	0.3 m	1531265	SDAT-MHS-M50-1L-SA-E-0.3-M8
	0 ... 80.000 mm				1531266	SDAT-MHS-M80-1L-SA-E-0.3-M8
	0 ... 100.000 mm				1531267	SDAT-MHS-M100-1L-SA-E-0.3-M8
	0 ... 125.000 mm				1531268	SDAT-MHS-M125-1L-SA-E-0.3-M8
	0 ... 160.000 mm				1531269	SDAT-MHS-M160-1L-SA-E-0.3-M8

Position transmitter SMAT-8M for T-slot, M8 plug, A-coded

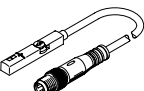
	Sensing range	Analogue output	Electrical connection 1, number of connections/cores	Cable length	Part no.	Type
	52 mm	0 - 10 V	4	0.3 m	553744	SMAT-8M-U-E-0,3-M8D

Connecting cables NEBU, straight

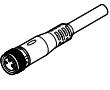
	Electrical connection 1, connector system	Electrical connection 2, connector system	Electrical connection 2, number of connections/cores	Cable length	Part no.	Type
	M8x1, A-coded, to EN 61076-2-104	Open end	4	2.5 m	541342	NEBU-M8G4-K-2.5-LE4
				5 m	541343	NEBU-M8G4-K-5-LE4

Accessories

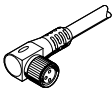
Connecting cables NEBU, angled						
	Electrical connection 1, connector system	Electrical connection 2, connector system	Electrical connection 2, number of connections/cores	Cable length	Part no.	Type
	M8x1, A-coded, to EN 61076-2-104	Open end	4	2.5 m	541344	NEBU-M8W4-K-2.5-LE4
				5 m	541345	NEBU-M8W4-K-5-LE4