

## Parallel kinematic system EXPT, tripod

**FESTO**



## Key features

### At a glance

The high-speed handling unit with robot functionality for free movement in three dimensions provides precision in movement and positioning as well as a high dynamic response of up to 150 picks/min.

The highly rigid mechanical design and low moving mass make the parallel kinematic system with toothed belt axes up to three times as fast as comparable Cartesian systems.

Three double rods keep the front unit horizontal at all times. The axes and servo motors do not move with the unit.

The parallel kinematic system is suitable for handling loads of up to max. 5 kg.

Typical applications include:

- Picking & placing small parts
- Gluing
- Labelling
- Palletising
- Sorting
- Grouping
- Repositioning and separating

### Comparison between parallel kinematic and Cartesian systems

#### Parallel kinematic system

- Low moving mass – ideal for demanding requirements on dynamic response in three dimensions
- High path accuracy with a range of path profiles, even for highly dynamic operation
- Four sizes with a working space diameter of up to 1200 mm

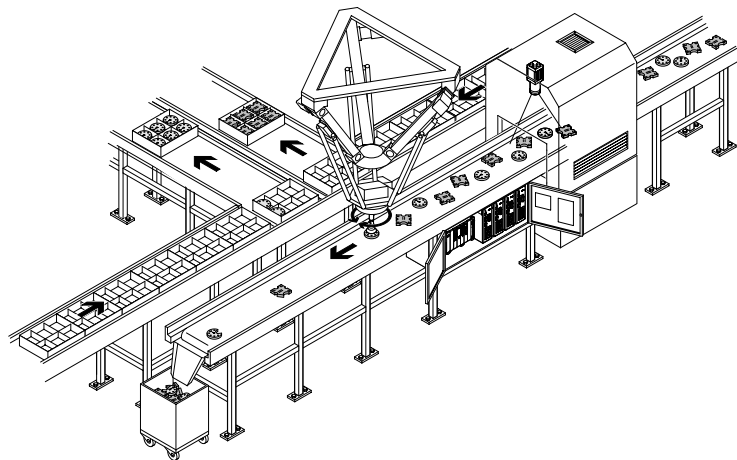

#### Cartesian system

- Axes build on one another; the first axis carries all the subsequent axes
- High moving mass, therefore much lower dynamic response
- Rectangular, scalable working space
- Based on standard components
- Flexible designs

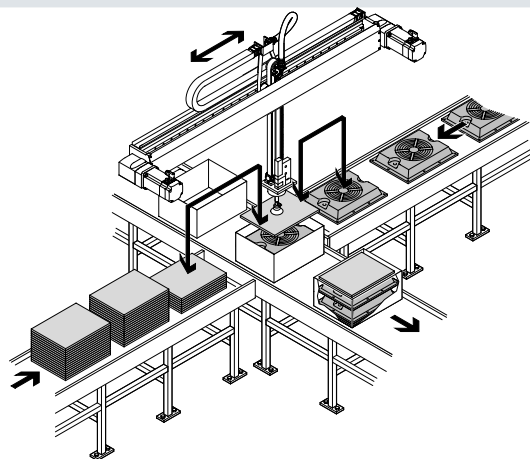

## Key features

### The technology in detail

#### Parallel kinematic system

- |  |   |
|--|---|
| [1] Mounting frame                         | [7] Angle kit → page 26                                   |
| [2] Mounting bracket for toothed belt axis | [8] Protective conduit → page 26                          |
| [3] Motor                                  | [9] Toothed belt axis                                     |
| [4] Connection block                       | [10] Tubing holder → page 26                              |
| [5] Pair of rods                           | [11] Front unit for mounting a gripper, etc.<br>→ page 18 |
| [6] Interface housing                      |   |



#### Front unit

→ Page 18

The front unit can optionally be ordered via the modular product system. It includes a gear motor that enables rotary movement (fourth axis) and is available in two sizes.

The front unit can also be chosen with or without rotary through-feed, for vacuum or excess pressure.

A range of grippers can be attached to it → Page 27.



## Key features

### Available working space

There are four sizes available with different working space diameters.

The possible working space can more simply be described using the shape of a cylinder (→ drawing).

The larger the working space required, the smaller its diameter (→ graph).

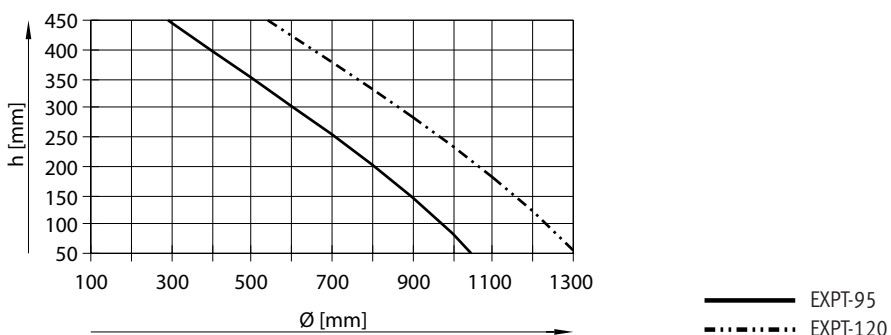
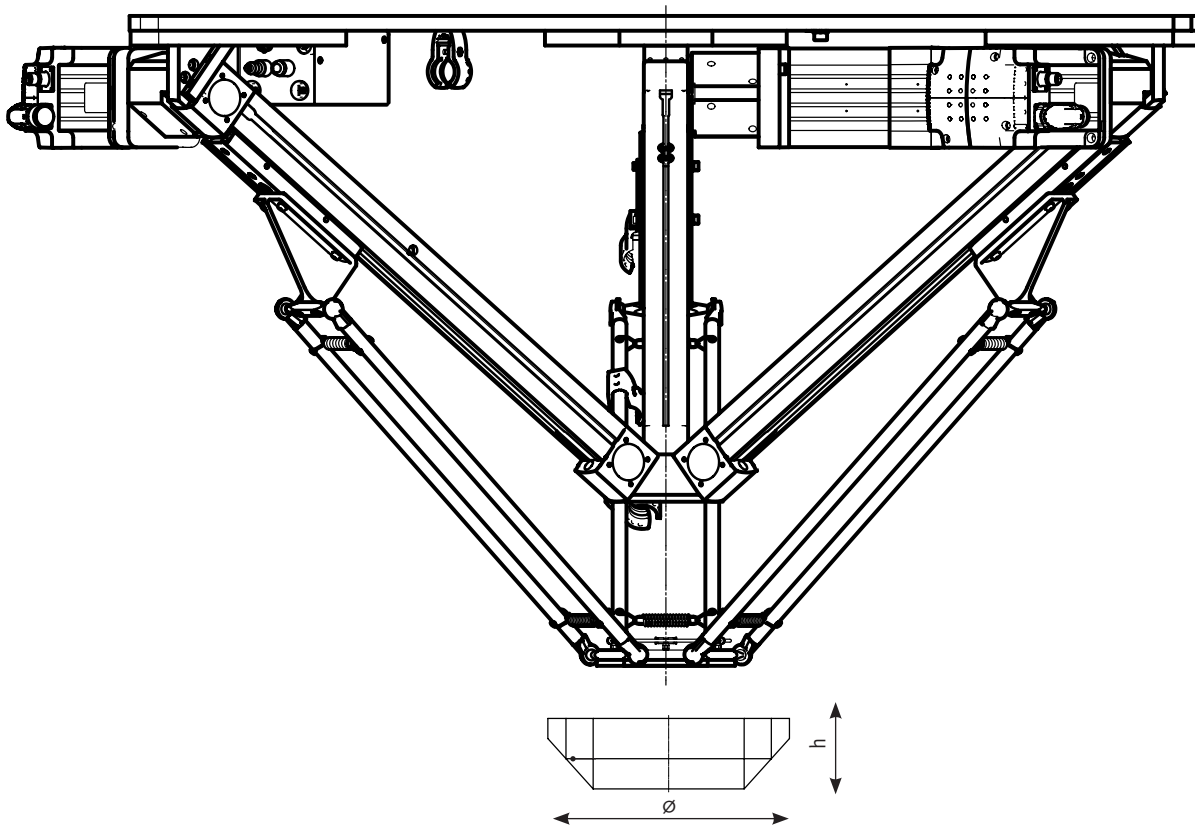

## Key features

### Motor mounting variants

The attachment position of the motors can be individually configured via the modular product system (→ page 24).

The standard motor attachment position corresponds to code HHH (cf. illustration below). This means: A1/A2/A3 rear.

If a motor is to be attached on the front, a 'V' must be specified in the order code for the respective axis.

The position of the interface housing depends on the position of the motor (V or H) on axis A1.

Code	Description
HHH	A1/A2/A3 rear
HHV	A3 front; A1/A2 rear
HVH	A2 front; A1/A3 rear
HVV	A2/A3 front; A1 rear
VHH	A1 front; A2/A3 rear
VHV	A1/A3 front; A2 rear
VVH	A1/A2 front; A3 rear
VVV	A1/A2/A3 front

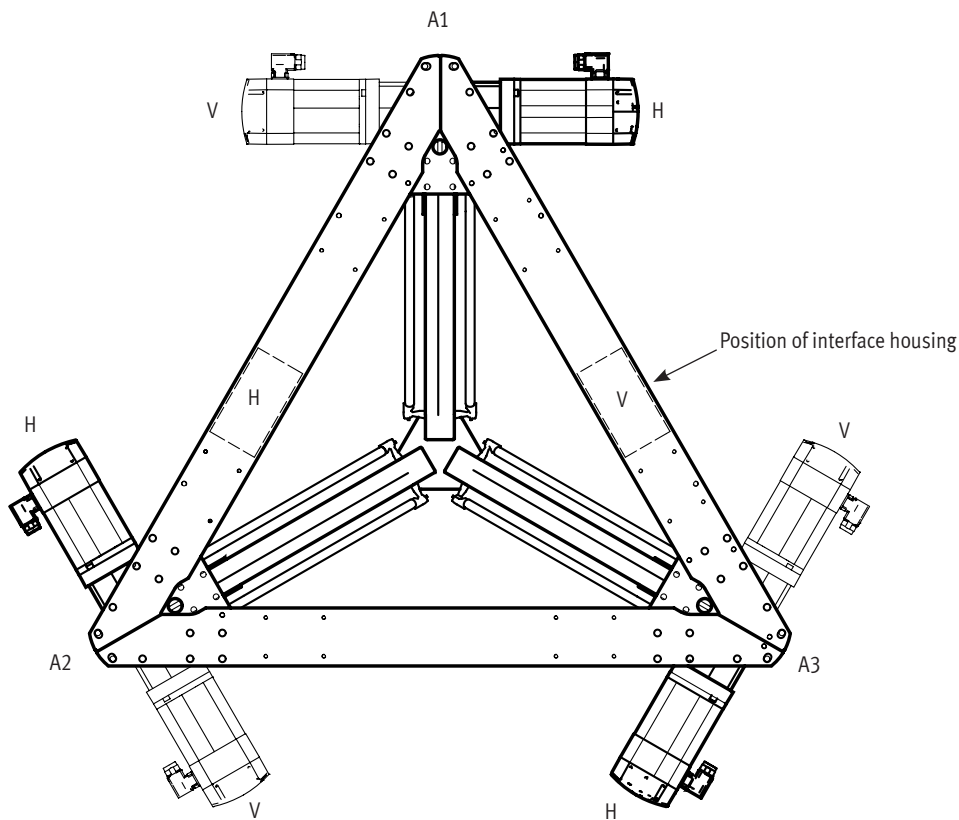

Coordinate system

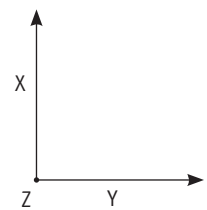

## Key features

### Protection against particles

Installation type: protected version (P8)

Abrasion on the toothed belt can lead to loose particles falling into the working space in the basic design.

If the variant EXPT-...-P8 (→ page 24) is selected, the axes are turned during installation (slide on top). A covering kit EASC-E10 (→ page 26) can additionally be ordered as a separate accessory and fitted; this prevents these particles from entering the working space. They slide downwards into the troughs and collect in the cover (see below).

#### Standard

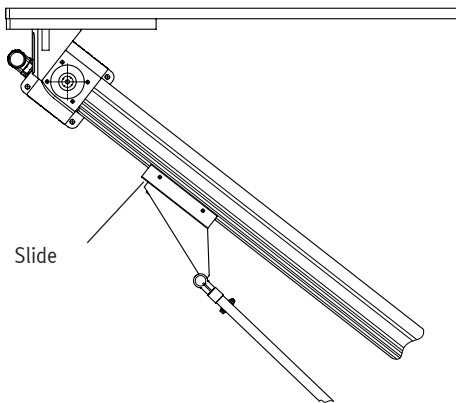

#### Protected version (P8)

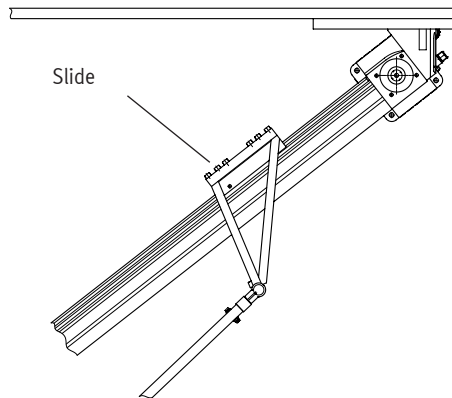

#### Protected version (feature P8 in the modular product system) with covering kit EASC-E10 (ordered separately as an accessory)

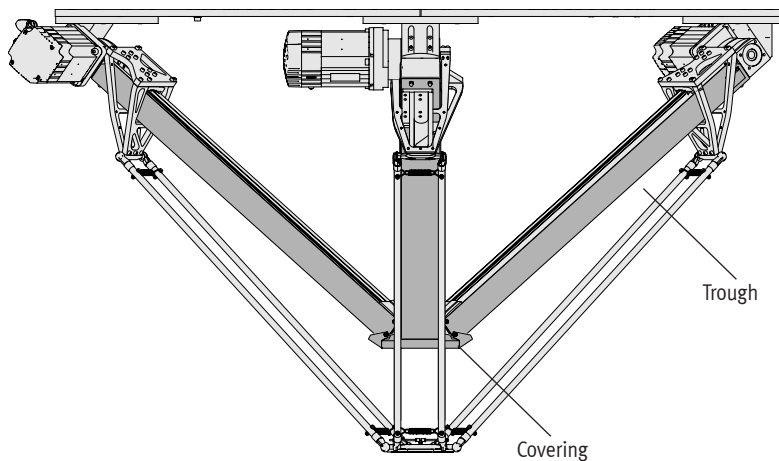

#### Easy mounting of the covering kit EASC-E10

##### Mounting the troughs

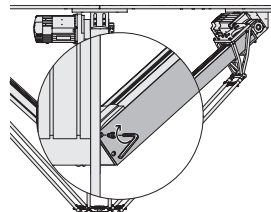
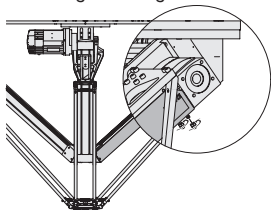

##### Fitting the covering

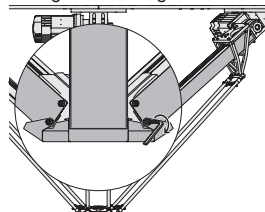

## Type codes

<b>001</b>	<b>Series</b>	
<b>EXPT</b>	Parallel kinematic system	

<b>002</b>	<b>Working space</b>	
<b>95</b>	950 mm	
<b>120</b>	1200 mm	

<b>003</b>	<b>Drive</b>	
<b>E1</b>	DGE-25	
<b>E4</b>	EGC-80	

<b>004</b>	<b>Attachment components</b>	
<b>T0</b>	None	
<b>T1</b>	Rotary drive, size 8	
<b>T2</b>	Rotary drive, size 8 with pn. rotary feed-through	
<b>T3</b>	Rotary drive, size 11	
<b>T4</b>	Rotary drive, size 11 with pn. rotary feed-through	

<b>005</b>	<b>Motor attachment position</b>	
<b>HHH</b>	A1/A2/A3 rear	
<b>HHV</b>	A3 front, A1/A2 rear	
<b>HVH</b>	A2 front, A1/A3 rear	
<b>HVV</b>	A2/A3 front, A1 rear	
<b>VHH</b>	A1 front, A2/A3 rear	
<b>VHV</b>	A1/A3 front, A2 rear	
<b>VVH</b>	A1/A2 front, A3 rear	
<b>VVV</b>	A1/A2/A3 front	

<b>006</b>	<b>Protection against particles</b>	
	Standard	
<b>P8</b>	Protected version	

<b>007</b>	<b>Cable length</b>	
	None	
<b>5K</b>	5 m	
<b>10K</b>	10 m	
<b>15K</b>	15 m	

<b>008</b>	<b>Presetting</b>	
	Standard	
<b>S</b>	With calibration	

<b>009</b>	<b>Document language</b>	
<b>DE</b>	German	
<b>EN</b>	English	
<b>ES</b>	Spanish	
<b>FR</b>	French	
<b>IT</b>	Italian	
<b>RU</b>	Russian	
<b>ZH</b>	Chinese	

## Peripherals overview

### Variant examples

Order code: EXPT-...-E4-T2-HHH-...

E4: Drive: EGC-80

T2: Attachment component: rotary drive, size 8 with pneumatic air through-feed

HHH: Attachment position of motor: A1/A2/A3 at the rear

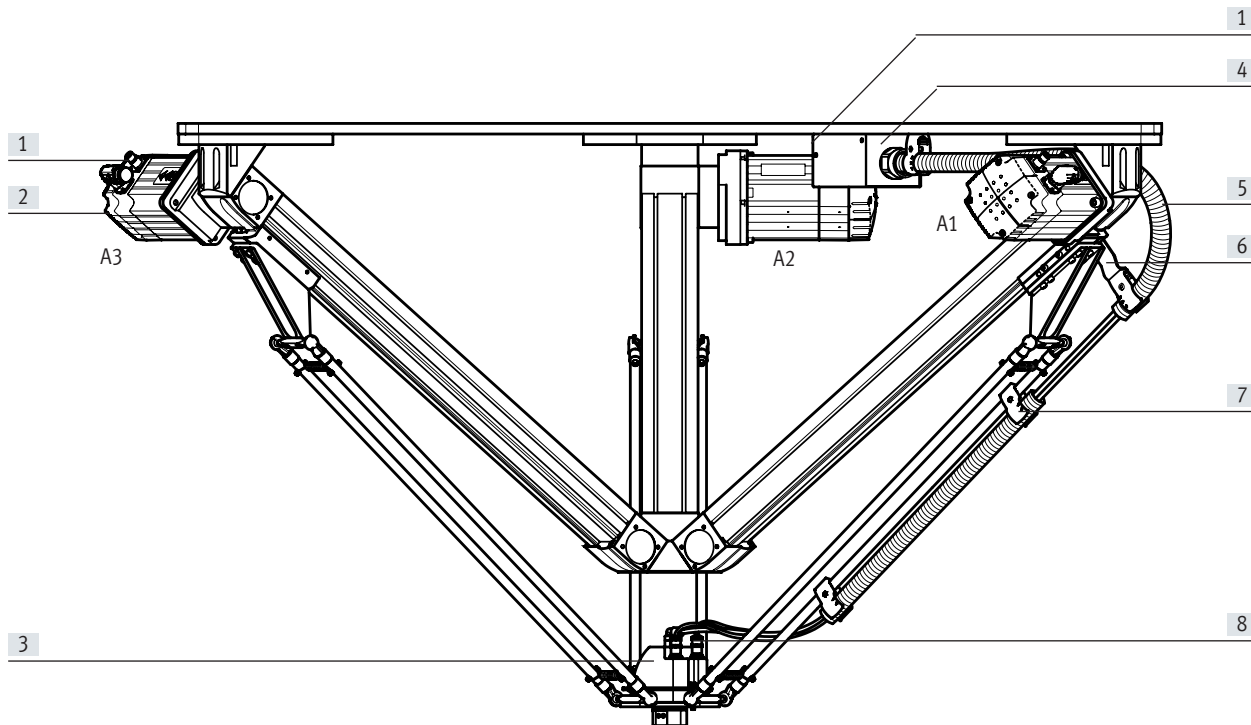

Order code: EXPT-...-E4-T0-HVV-P8-... with covering kit EASC-E10-...

E4: Drive: EGC-80

T0: Attachment component: no rotary drive

HVV: Attachment position of motor: A1 at rear, A2/A3 at the front

P8: Protection against particles: protected version

Covering kit EASC-E10 must be ordered separately as an accessory.

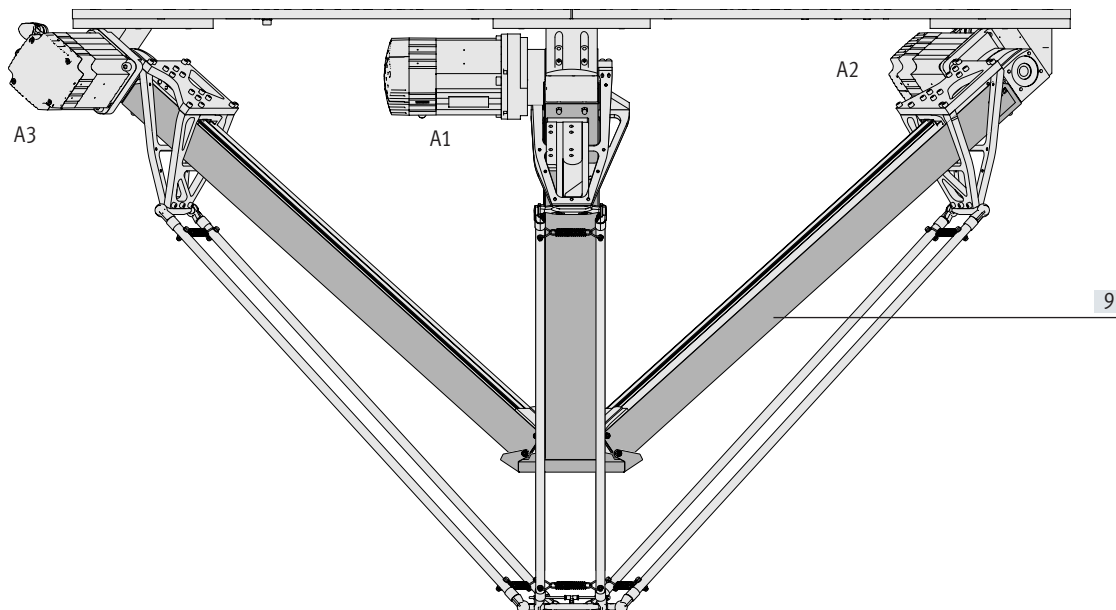



## Peripherals overview

Attachments and accessories		
Type	Description	→ Page/Internet
[1] Connecting cable NEBM	For the motors and the interface housing	25
[2] Servo motor HHH, HHV, ...	The attachment position of the motors can be defined via the modular product system (HHH ... WV). Homing is not required thanks to a multi-turn rotary encoder	-
[3] Front unit T0, T1, T2, ...	Choose from: <ul style="list-style-type: none"> <li>• Front unit without rotary drive (T0)</li> <li>• Front unit with rotary drive (T1 to T4)</li> </ul>	-
[4] Interface housing	Serves as the interface between the parallel kinematic system and the control cabinet to supply the front unit	-
[5] Protective conduit MKG	Is pre-assembled for all variants (T0 to T4), on axis A1	26
[6] Angle kit EAHM-E10	Is pre-assembled for all variants (T0 to T4), on axis A1. If required, further angle kits can be ordered as accessories	26
[7] Tubing holder EAHM-E10-TH	Is pre-assembled for all variants (T0 to T4), on axis A1. If required, further tubing holders can be ordered as accessories	26
[8] Front unit installation	The cables that supply the front unit are already installed between the front unit and the interface housing	-
[9] Covering kit EADC-E10	Protects the working space against contamination by particles. The kit must be fitted by the customer	26

## Datasheet

Size  
95, 120

 www.festo.com



General technical data			
Size		95	120
Design	Parallel kinematic system		
Motor type	Servo motor		
Mounting position	Horizontal		
Working space			
Nominal diameter	[mm]	950	1200
Nominal height	[mm]	100	100
Max. acceleration <sup>1)</sup>	[m/s <sup>2</sup> ]	110	
Max. speed <sup>1)</sup>	[m/s]	7	
Max. pick rate <sup>1)2)</sup>	[picks/min]	140	
Repetition accuracy	[mm]	±0.1	
Positioning accuracy <sup>3)</sup>	[mm]	±0.5	
Track precision <sup>3)4)</sup>	[mm]	±0.5	
Nominal load <sup>5)</sup>			
With min. dynamic response	[kg]	5	
With max. dynamic response	[kg]	1	
Base weight	[kg]	61.5	66

- 1) When used in combination with servo drive CMMT-AS-C5-11A.
- 2) In the 12° cycle.
- 3) Only with calibrated system (order code S).
- 4) At a speed of ≤0.3 m/s.
- 5) Rated load = tool load (accessories attached to the front unit) + payload

Max. process force in Z-direction			
Size		95	120
With working space diameter	[mm]	0	0
Process force	[N]	1000	850
With working space diameter <sup>6)</sup>	[mm]	237.5	300
Process force	[N]	750	750

- 6) The specified values correspond to 25% of the nominal diameter.

Operating and environmental conditions		
Ambient temperature	[°C]	0 ... +40
Storage temperature	[°C]	-10 ... +60
Operating pressure for rod loss detection	[bar]	2 ... 8
Duty cycle <sup>7)</sup>	[%]	100
Corrosion resistance class CRC <sup>8)</sup>		2

- 7) When used in combination with servo drive CMMT-AS-C5-11A.
- 8) Corrosion resistance class CRC 2 to Festo standard FN 940070  
Moderate corrosion stress. Indoor applications in which condensation can occur. External visible parts with primarily decorative surface requirements which are in direct contact with a normal industrial environment.

## Datasheet

### Materials

Sectional view

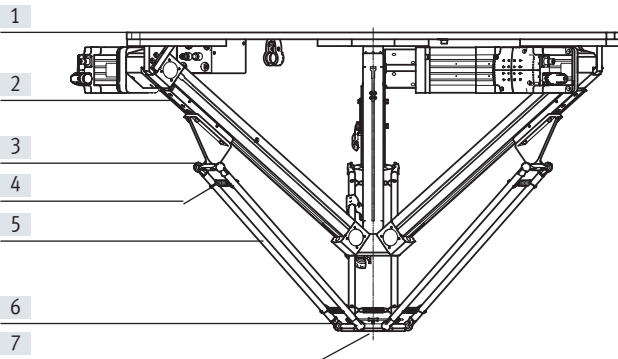

Parallel kinematic system		
[1]	Mounting frame	Wrought aluminium alloy
[2]	Toothed belt axis DGE/EGC	→ Internet: dge, egc
[3]	Ball stud	Wrought aluminium alloy
[4]	Tension spring	High-alloy stainless steel
[5]	Pair of rods	Carbon fibre-reinforced plastic
[6]	Ball cup	Polyamide
	Ball	Ceramic
[7]	Front unit	Wrought aluminium alloy
-	Note on materials	Contains paint-wetting impairment substances Free of copper and PTFE

### Rod loss detection

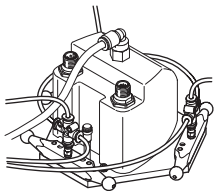

The rod loss detection feature detects detached rods and initiates an emergency stop.

This is realised using permanent compressed air monitoring (pressure switch integrated in the interface housing on the frame)

This is done by pressurising the ball cup connections of the front unit with compressed air at 2 bar (rel.).

Connections on the interface housing:

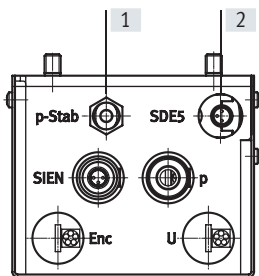

[1] Compressed air supply for rod loss detection.  
The compressed air is adjusted to 2 bar in the interface housing.

[2] Pressure sensor for monitoring rod loss detection.  
Connecting cable  
→ Page 24

### Pick rate as a function of rated load

The characteristic values for dynamic response are determined in so-called 12" cycles. The graph below shows the maximum number of possible cycles as a function of rated load. It is based on an accuracy of  $\pm 0.5$  mm.

One 12" cycle means:  
[1] To the gripping position  
[2] To the start position  
[3] To the transfer position  
[4] To the set-down position  
[5] To the transfer position  
[6] To the start position

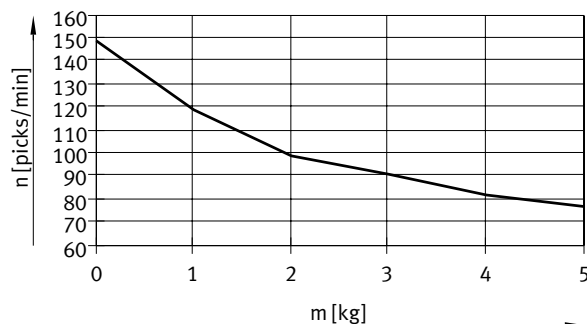
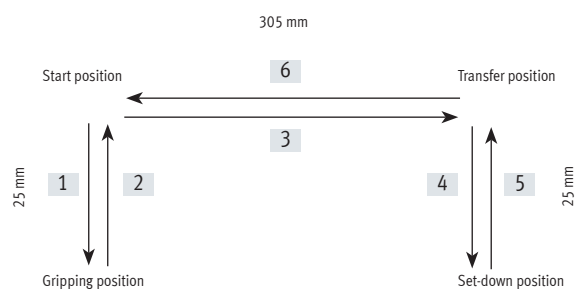

n = cycles per minute  
M = rated load

Datasheet

Max. acceleration  $a$  as a function of the position in the working space  $R$  and distance  $l$ , from the centre of gravity of the rated load  $m$  to the front unit

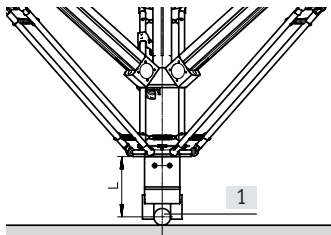

EXPT-95

Rated load of 0.1 kg

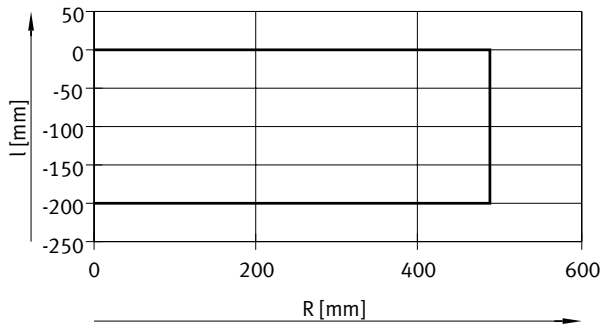

Rated load of 0.5 kg

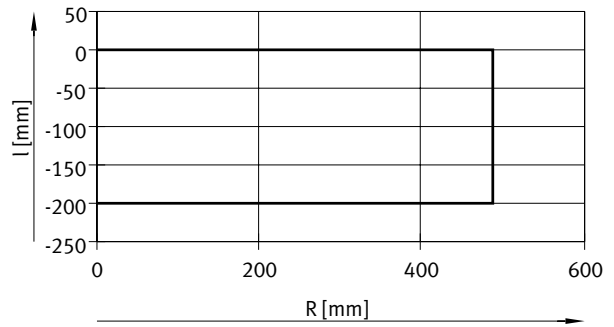

Rated load of 1 kg

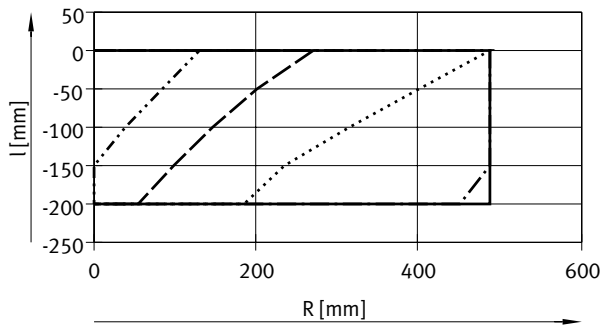

Rated load of 1.5 kg

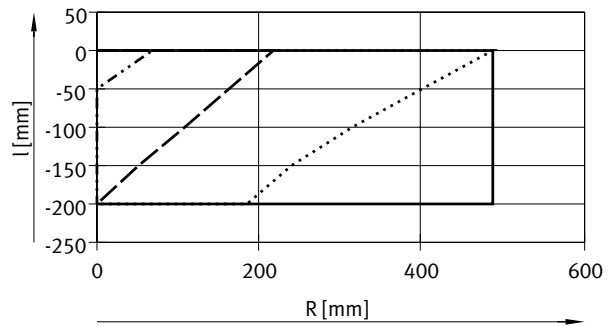

- $a = 0 \dots 60$  m/s<sup>2</sup>
- .....  $a = 100$  m/s<sup>2</sup>
- $a = 90$  m/s<sup>2</sup>
- · - · -  $a = 80$  m/s<sup>2</sup>
- $a = 70$  m/s<sup>2</sup>

- $a = 0 \dots 50$  m/s<sup>2</sup>
- .....  $a = 80$  m/s<sup>2</sup>
- $a = 70$  m/s<sup>2</sup>
- $a = 60$  m/s<sup>2</sup>

Datasheet

Max. acceleration  $a$  as a function of the position in the working space  $R$  and distance  $l$ , from the centre of gravity of the rated load  $m$  to the front unit

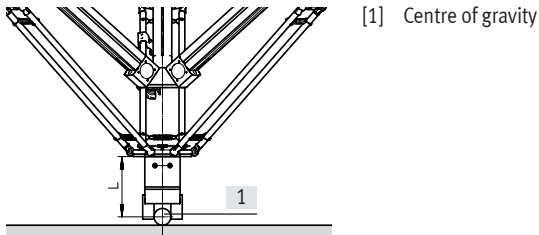

EXPT-95

Rated load of 2 kg

Rated load of 3 kg

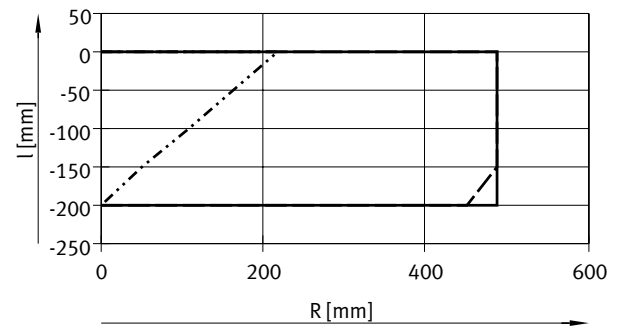
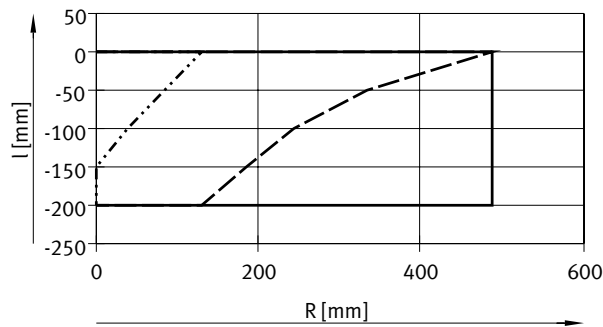

—  $a = 0 \dots 40$  m/s<sup>2</sup>  
 .....  $a = 60$  m/s<sup>2</sup>  
 - - -  $a = 50$  m/s<sup>2</sup>

—  $a = 0 \dots 20$  m/s<sup>2</sup>  
 .....  $a = 40$  m/s<sup>2</sup>  
 - - -  $a = 30$  m/s<sup>2</sup>

Rated load of 4 kg

Rated load of 5 kg

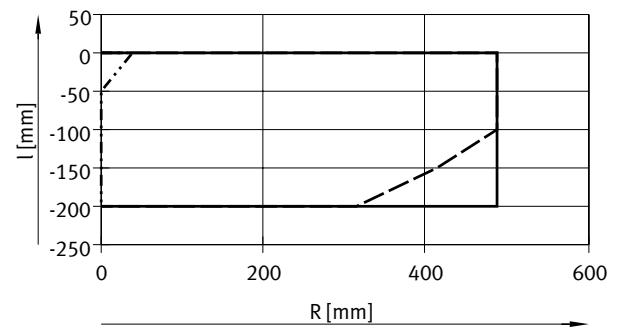
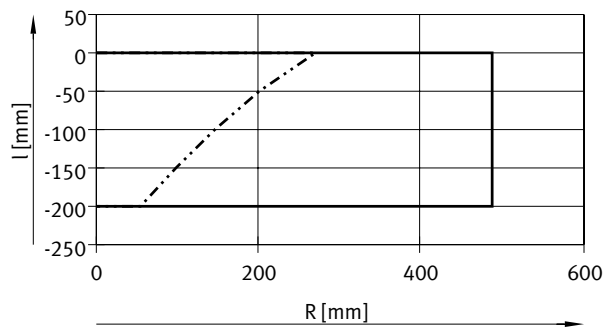

—  $a = 0 \dots 20$  m/s<sup>2</sup>  
 .....  $a = 30$  m/s<sup>2</sup>

—  $a = 0 \dots 10$  m/s<sup>2</sup>  
 .....  $a = 30$  m/s<sup>2</sup>  
 - - -  $a = 20$  m/s<sup>2</sup>

Datasheet

Max. acceleration  $a$  as a function of the position in the working space  $R$  and distance  $l$ , from the centre of gravity of the rated load  $m$  to the front unit

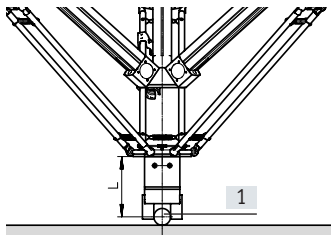

[1] Centre of gravity

EXPT-120

Rated load of 0.1 kg

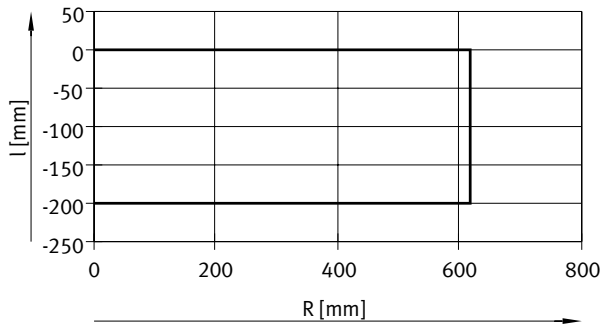

—  $a = 0 \dots 100 \text{ m/s}^2$

Rated load of 0.5 kg

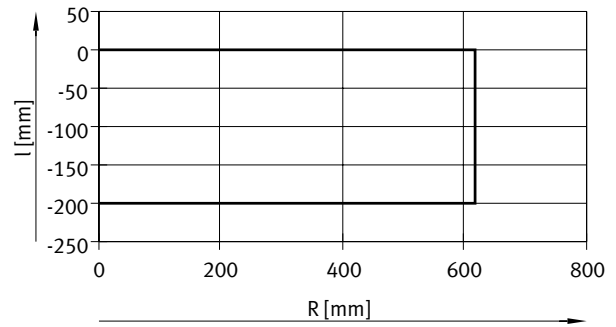

—  $a = 0 \dots 100 \text{ m/s}^2$

Rated load of 1 kg

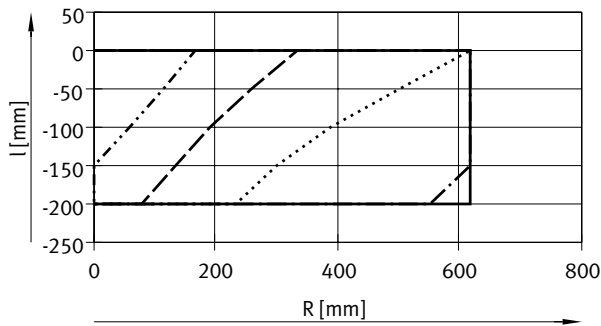

—  $a = 0 \dots 60 \text{ m/s}^2$   
 - - -  $a = 100 \text{ m/s}^2$   
 - - -  $a = 90 \text{ m/s}^2$   
 ·····  $a = 80 \text{ m/s}^2$   
 - · -  $a = 70 \text{ m/s}^2$

Rated load of 1.5 kg

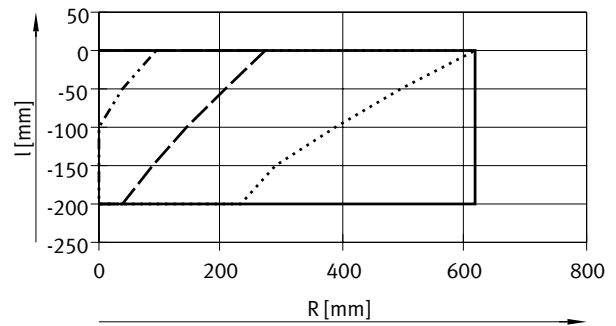

—  $a = 0 \dots 50 \text{ m/s}^2$   
 - - -  $a = 80 \text{ m/s}^2$   
 - - -  $a = 70 \text{ m/s}^2$   
 ·····  $a = 60 \text{ m/s}^2$

Datasheet

Max. acceleration  $a$  as a function of the position in the working space  $R$  and distance  $l$ , from the centre of gravity of the rated load  $m$  to the front unit

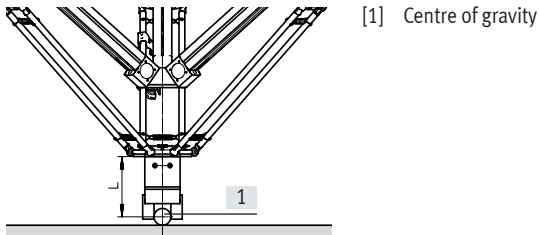

EXPT-120

Rated load of 2 kg

Rated load of 3 kg

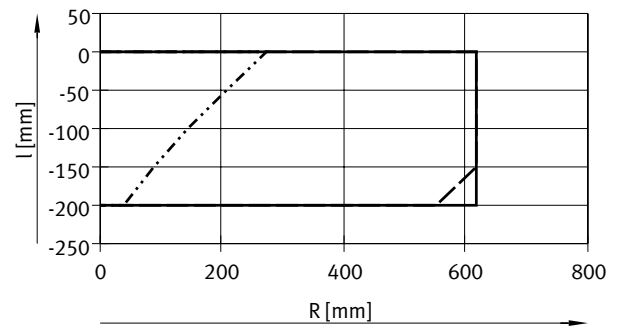
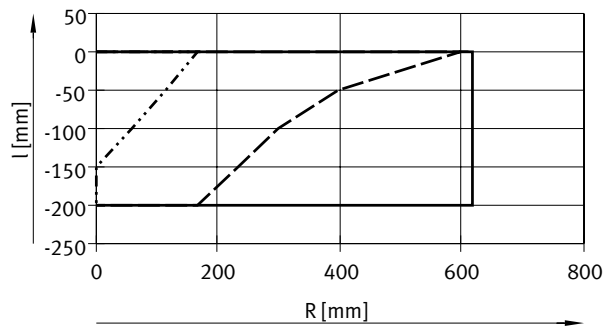

—  $a = 0 \dots 40$  m/s<sup>2</sup>  
 .....  $a = 60$  m/s<sup>2</sup>  
 - - -  $a = 50$  m/s<sup>2</sup>

—  $a = 0 \dots 20$  m/s<sup>2</sup>  
 .....  $a = 40$  m/s<sup>2</sup>  
 - - -  $a = 30$  m/s<sup>2</sup>

Rated load of 4 kg

Rated load of 5 kg

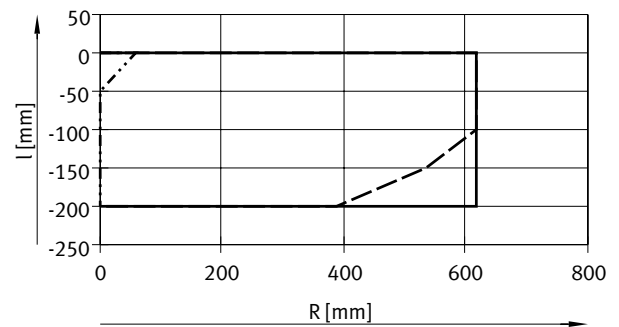
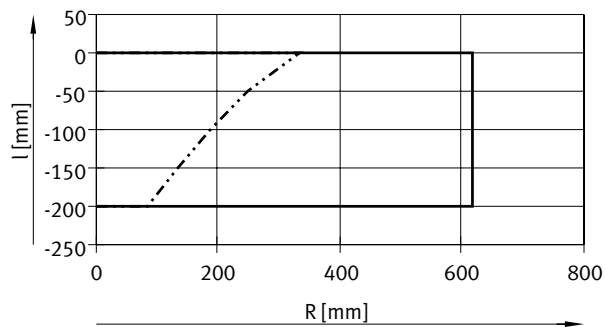

—  $a = 0 \dots 20$  m/s<sup>2</sup>  
 .....  $a = 30$  m/s<sup>2</sup>

—  $a = 0 \dots 10$  m/s<sup>2</sup>  
 .....  $a = 30$  m/s<sup>2</sup>  
 - - -  $a = 20$  m/s<sup>2</sup>

## Datasheet

### Requirements for the frame

The positioning and path accuracy depends to a large extent on the design of the frame.

The following influences must therefore be taken into consideration:

- Rigidity of frame
- Mass of frame
- Mass of the parallel kinematic system

- Start-up frequency caused by dynamic operation of the parallel kinematic system
  - Cycles per minute
  - Dynamic settings for acceleration and jerk

Maximum forces occur if two axes accelerate in the opposite direction to the third and result in horizontal movement of the rated load.

The frame must be designed so that the maximum forces that can occur can be absorbed with the necessary degree of certainty.

The guide value for the first natural frequency is specified to be at least 16 Hz for the complete system.

At the maximum dynamic response of the axes, the following forces act on the corner brackets of the mounting frame and thus on the fastening in the frame.

Size		95	120
Vertical force	[N]	±325	±475
Horizontal force	[N]	±200	±215

### Mounting options on the frame

The parallel kinematic system must always be mounted in the corner brackets of the mounting frame. Ensure that the corner bracket area has a torsionally rigid, flat bearing surface.

The bearing surface must meet the following minimum requirements in order to achieve the positioning accuracy:

- Flatness = 0.05 mm
- Parallelism = 0.5 mm

Since the distance between the slots is 40 mm in the 80x80 profile, the drilled holes in the corner brackets have been positioned so that the profile can be mounted in various positions.

Since the homing settings of the corresponding axis are lost when the motor is dismantled, it is recommended to use mounting holes that do not require the motor to be removed.

The drilled holes [1] are not accessible, depending on the attachment position of the motor.

#### Direct mounting via screws

Screws M8x...

Via at least 4 screws (M8) per corner bracket directly on the frame. These 4 screws should be placed as far apart as possible to ensure a torsionally rigid connection.

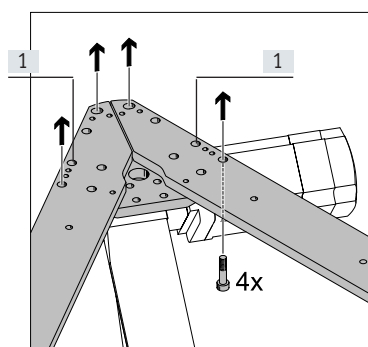

#### Screws M20x...

Via 1 screw (M20) per corner bracket directly on the frame. There is a central drilled hole on each bracket for this purpose.

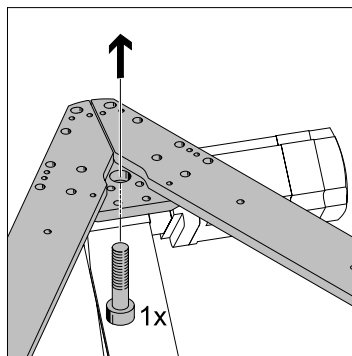



## Datasheet

### Mounting options on the frame

Mounting via slot nuts – parallel to the mounting frame

- |                                       |                            |
|---------------------------------------|----------------------------|
| [1] Profile<br>(e.g. HMBS-8 0/80)     | [3] Screws<br>(e.g. M8x35) |
| [2] Slot nut<br>(e.g. NST-HMV-8-2-M8) |                            |

#### Example 1

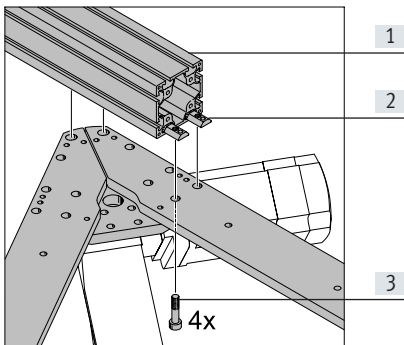

#### Example 2

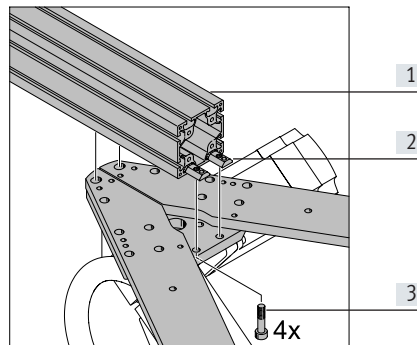

Mounting via slot nuts – at right angles to the mounting frame

- |                                       |                            |
|---------------------------------------|----------------------------|
| [1] Profile<br>(e.g. HMBS-8 0/80)     | [3] Screws<br>(e.g. M8x35) |
| [2] Slot nut<br>(e.g. NST-HMV-8-2-M8) | [4] Bracket                |

The additional brackets in the following examples are required in order to increase the torsional rigidity and the bearing surface.

#### Example 1

Mounting the profile

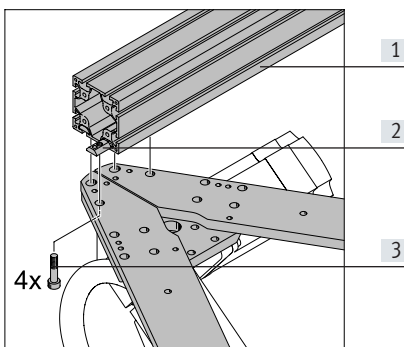

Mounting the bracket

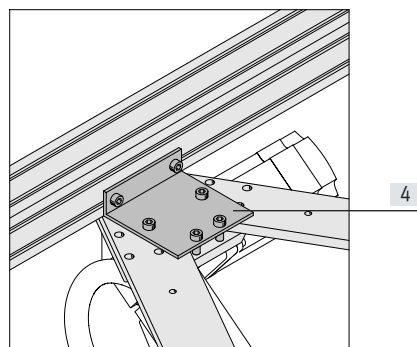

#### Example 2

Mounting the profile

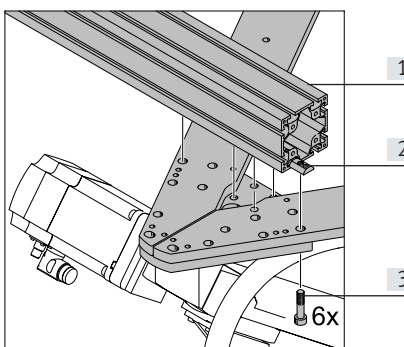

Mounting the bracket

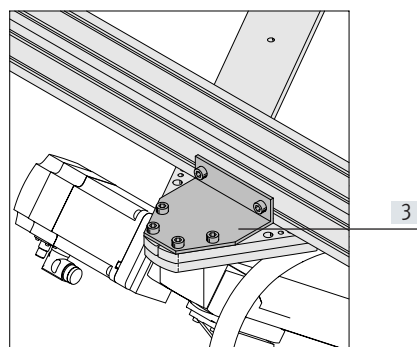

## Datasheet

### Technical data – Front unit

EXPT-...-T...



#### Mechanical data

Type	EXPT-...-			
	T1	T2	T3	T4
Design	Electromechanical rotary module			
	–	With rotary through-feed	–	With rotary through-feed
Motor type	Servo motor			
Size	8	8	11	11
Rotation angle	Infinite			
Pneumatic connection	–	G1/8	–	G1/8
Nominal width [mm]	–	4	–	4
Standard nominal flow rate [l/min]	–	350	–	350
Gear ratio	30:1			
Repetition accuracy [°]	±0.01			
Max. output speed [rpm]	200			
Nominal torque [Nm]	0.75	0.75	1.8	1.8
Peak torque [Nm]	1.8	1.8	4.5	4.5
Max. axial force [N]	200	200	300	300
Max. pull-out torque, static [Nm]	15	15	40	40
Perm. mass moment of inertia of load [kgm <sup>2</sup> ]	0.0026	0.0026	0.006	0.006
Mounting position	Any			
Load mass for EXPT [g]	640	690	850	900

#### Electrical data

Type	EXPT-...-			
	T1	T2	T3	T4
Nominal voltage [V AC]	230			
Nominal current [A]	0.31	0.31	0.74	0.74
Peak current [A]	0.61	0.61	1.5	1.5
Nominal power [W]	9.2	9.2	22.1	22.1
Duty cycle [%]	100			
Measuring system <sup>1)</sup>	Encoder			

1) Homing required

#### Operating and environmental conditions

Type	EXPT-...-			
	T1	T2	T3	T4
Operating pressure [bar]	–	–0.9 ... +10	–	–0.9 ... +10
Ambient temperature [°C]	0 ... 40			
Degree of protection	IP40			
Note on materials	RoHS-compliant			
Corrosion resistance class CRC <sup>1)</sup>	2			

1) Corrosion resistance class CRC 2 to Festo standard FN 940070

Moderate corrosion stress. Indoor applications in which condensation can occur. External visible parts with primarily decorative surface requirements which are in direct contact with a normal industrial environment.

## Datasheet

Connections on the interface housing:

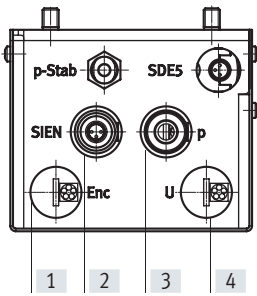

Connection for:

- [1] Encoder cable → page 24
- [2] Rotary motion sensing → page 24
- [3] Supply port for pneumatic rotary through-feed
- [4] Motor cable → page 24

### Dimensions

Download CAD data → [www.festo.com](http://www.festo.com)

Front unit

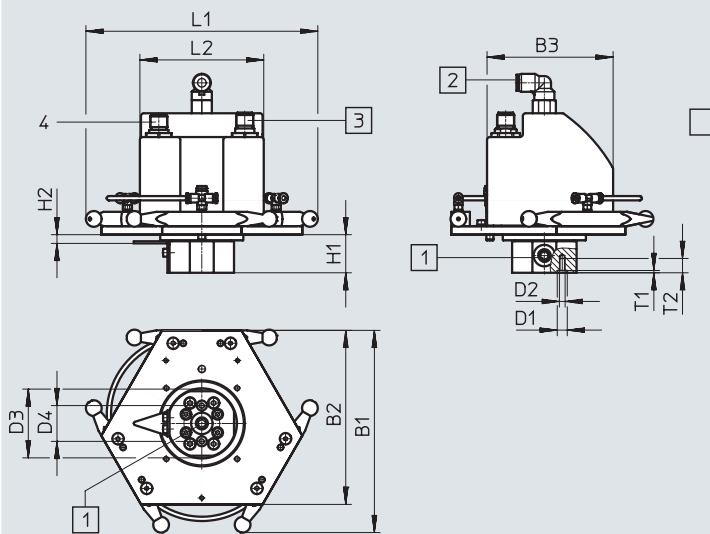

- [1] Supply port outlet
- [2] Supply port for rotary through-feed
- [3] Connection for motor cable
- [4] Connection for encoder cable

Type	B1	B2	B3	D1 ∅ H7	D2	D3 ∅	D4 ∅	H1	H2 +1	L1	L2	T1	T2
EXPT...	141	122	88	7	M4	48	25	27	6	162	86	1.6	10

## Datasheet

### Dimensions

Download CAD data → [www.festo.com](http://www.festo.com)

Parallel kinematic system

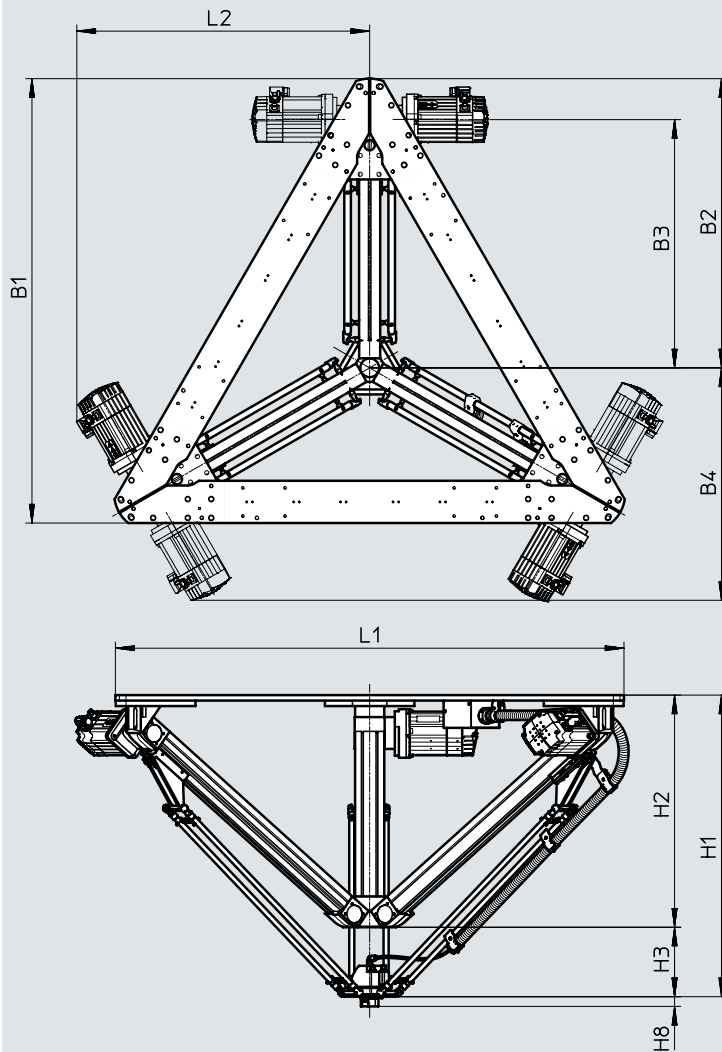

Type	B1	B2	B3	B4	H1	H2	H3	L1	L2
EXPT-95	1213	794	705	663	820	636	184	1394	826
EXPT-120	1355	888	800	716	938	710	228	1558	920

Datasheet

Dimensions

Download CAD data → [www.festo.com](http://www.festo.com)

Mounting holes on the mounting frame

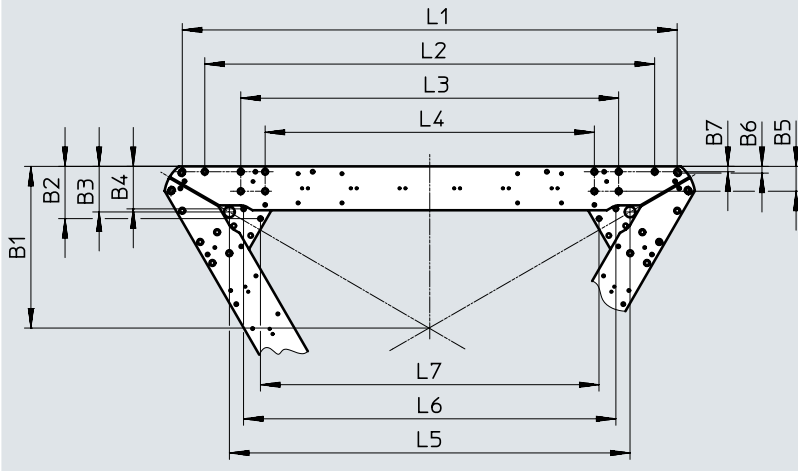

Type	B1	B2	B3	B4	B5	B6	B7
EXPT-95	419.3	107.2	93.5	87.2	51	12.3	11
EXPT-120	466.6	107.2	93.5	87.2	51	12.3	11

Type	L1	L2	L3	L4	L5	L6	L7
EXPT-95	1323.7	1229.7	1082.1	982.1	1128.7	1070.6	1001.3
EXPT-120	1487.5	1393.5	1245.9	1145.9	1292.5	1234.4	1165.1

## Datasheet

### Dimensions

Download CAD data → [www.festo.com](http://www.festo.com)

Interference contour within the nominal working area

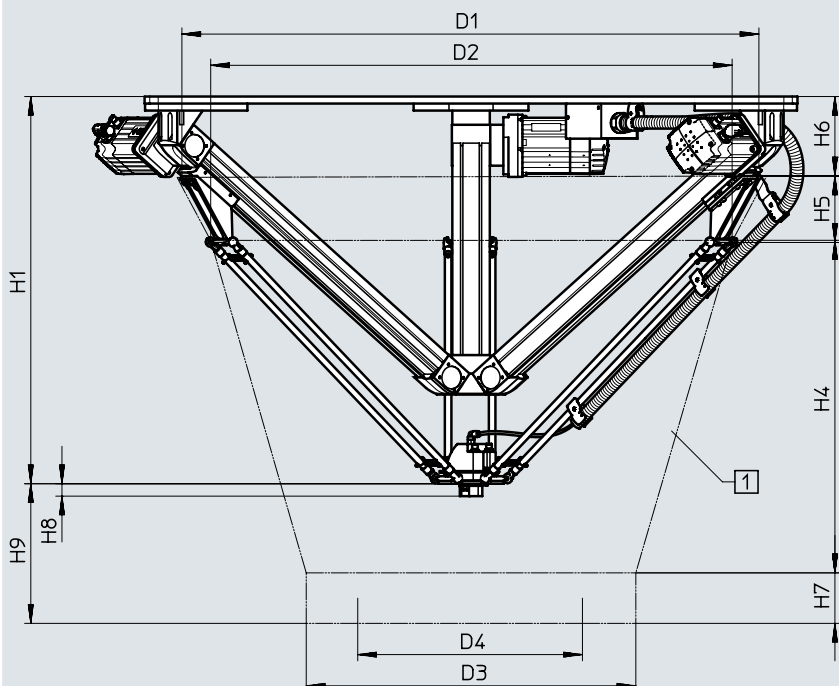

- [1] Interference contour
- D3 Diameter of interference contour
- D4 Diameter of nominal working area
- H7 Height of nominal working area
- H9 Distance from bottom edge of gripper plate to base of nominal working area

The distance specification for the working space refers to the bottom edge of the gripper plate. With the variants T1 to T4, the working space is extended downwards by the dimension H8. The same applies to attached gripper systems, where the reference point is always shifted by the height of the gripper system. Additional dimensions for laying the motor cables and tubing are not taken into account in the interference contour.

Type	D1 ±5	D2 ±5	D3 ±5	D4	H1	H4	H5
EXPT-95	1400	1260	1120	950	820	760	141
EXPT-120	1590	1440	1370	1200	938	907	141

Type	H6	H7	H8			H9
			EXPT...T0	EXPT...T1/T2	EXPT...T3/T4	
EXPT-95	170	100	0	27	28.5	357
EXPT-120	170	100	0	27	28.5	397



## Ordering data – Modular product system

Ordering table					
Size	95	120	Conditions	Code	Enter code
Module no.	<b>569799</b>	<b>569800</b>			
Product type	EXPT series T			<b>EXPT</b>	EXPT
Working space	[mm]	950	-	<b>-95</b>	
	[mm]		1200	<b>-120</b>	
Drive	EGC-80			<b>-E4</b>	-E4
Motor	Without motor			<b>-M4</b>	
Attachment components	EXPT series T			<b>-T0</b>	
	Rotary drive, size 8			<b>-T1</b>	
	Rotary drive, size 8 with pneum. air through-feed			<b>-T2</b>	
	Rotary drive, size 11			<b>-T3</b>	
	Rotary drive, size 11 with pneum. air through-feed			<b>-T4</b>	
Motor attachment position	A1/A2/A3 rear			<b>-HHH</b>	
	A3 front, A1/A2 rear			<b>-HHV</b>	
	A2 front, A1/A3 rear			<b>-HVH</b>	
	A2/A3 front, A1 rear			<b>-HVV</b>	
	A1 front, A2/A3 rear			<b>-VHH</b>	
	A1/A3 front, A2 rear			<b>-VHV</b>	
	A1/A2 front, A3 rear			<b>-VVH</b>	
	A1/A2/A3 front			<b>-VVV</b>	
Protection against particles	Standard				
	Protected version			<b>-P8</b>	
Presetting	Standard				
	With calibration			<b>-S</b>	

 **Note**

To order a parallel kinematic system, please get in touch with your local Festo contact.  
The parallel kinematic system may only be commissioned by a specially trained technician (robotics specialist).

The following knowledge is required:

- Specialist knowledge of robotics and CODESYS
- Knowledge of servo drive CMMT
- Knowledge of handling parallel kinematic systems

Allocation table

Parallel kinematic system EXPT	Servo drive CMMT
EXPT-...-T0-...	3x CMMT-AS-C5-11A
EXPT-...-T0-...	3x CMMT-AS-C5-11A
EXPT-...-T1 to T4-...	3x CMMT-AS-C5-11A, 1x CMMT-AS-C2-3A
EXPT-...-T1 to T4-...	3x CMMT-AS-C5-11A, 1x CMMT-AS-C2-3A

 **Note**

Servo drives must be ordered separately as an accessory.  
Control system on request.

Ordering data – Servo drive

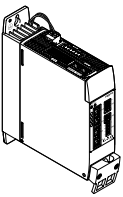
	For size	Output voltage [V AC]	Nominal current per phase [A]	Nominal power [VA]	Part no.	Type
	<b>For parallel kinematic system</b>					
	95, 120	3x 0 ... 270	5	2500	<b>5340823</b>	<b>CMMT-AS-C5-11A-P3-EC-S1</b>
	<b>For attachment component</b>					
	95, 120	3x 0 ... 270	2	350	<b>5340819</b>	<b>CMMT-AS-C2-3A-EC-S1</b>

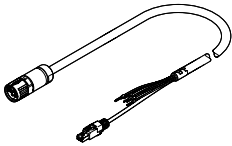

## Accessories

Ordering data – Motor cable				
	Cable cross section	Cable length [m]	Part no.	Type
	0.75 mm <sup>2</sup>	2.5	5251374	NEBM-M23G15-EH-2.5-Q7N-R3LEG14
		5	5251375	NEBM-M23G15-EH-5-Q7N-R3LEG14
		7.5	5251376	NEBM-M23G15-EH-7.5-Q7N-R3LEG14
		10	5251377	NEBM-M23G15-EH-10-Q7N-R3LEG14
		15	5251378	NEBM-M23G15-EH-15-Q7N-R3LEG14
		20	5251379	NEBM-M23G15-EH-20-Q7N-R3LEG14
	X length <sup>1)</sup>	5251373	NEBM-M23G15-EH-...-Q7N-R3LEG14	
	1.5 mm <sup>2</sup>	2.5	5251381	NEBM-M23G15-EH-2.5-Q9N-R3LEG14
		5	5251382	NEBM-M23G15-EH-5-Q9N-R3LEG14
		7.5	5251383	NEBM-M23G15-EH-7.5-Q9N-R3LEG14
		10	5251384	NEBM-M23G15-EH-10-Q9N-R3LEG14
		15	5251385	NEBM-M23G15-EH-15-Q9N-R3LEG14
		20	5251386	NEBM-M23G15-EH-20-Q9N-R3LEG14
	X length <sup>1)</sup>	5251380	NEBM-M23G15-EH-...-Q9N-R3LEG14	
	2.5 mm <sup>2</sup>	2.5	5251388	NEBM-M23G15-EH-2.5-Q10N-R3LEG14
		5	5251389	NEBM-M23G15-EH-5-Q10N-R3LEG14
		7.5	5251390	NEBM-M23G15-EH-7.5-Q10N-R3LEG14
		10	5251391	NEBM-M23G15-EH-10-Q10N-R3LEG14
15		5251392	NEBM-M23G15-EH-15-Q10N-R3LEG14	
20		5251393	NEBM-M23G15-EH-20-Q10N-R3LEG14	
X length <sup>1)</sup>	5251387	NEBM-M23G15-EH-...-Q10N-R3LEG14		

1) Choice of cable lengths: 0.5 ... 99.9 m, in increments of 0.1 m.

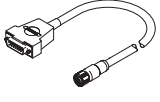
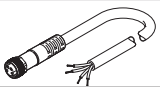
Ordering data			
	Cable length [m]	Part no.	Type
<b>Connection from the interface housing to the servo drive</b>			
	<b>Motor cable NEBM</b>		
	15	571907	NEBM-M12G4-RS-15-N-LE4
Included in the scope of delivery of the parallel kinematic system EXPT in combination with features T1 to T4.			
	<b>Encoder cable NEBM</b>		
	15	571915	NEBM-M12G12-RS-15-N-S1G15
Included in the scope of delivery of the parallel kinematic system EXPT in combination with features T1 to T4. An additional cable is required for connection to the servo drive → front unit ERMH/support			
<b>Connecting cable NEBU for rod loss detection or reference sensor of the rotary drive</b>			
	5	541334	NEBU-M8G3-K-5-LE3
	10	541332	NEBU-M8G3-K-10-LE3
	15	575986	NEBU-M8G3-K-15-LE3

## Accessories

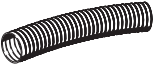
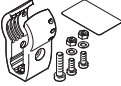
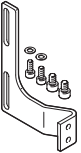
Ordering data				
	For size	Description	Part no.	Type
<b>Protective conduit MKG</b>				
	95, 120	2 m are required per axis	<b>3156318</b>	<b>MKG-23-PG-29-B</b>
<b>Tubing holder EAHM</b>				
	95, 120	For mounting the protective conduit	<b>3506553</b>	<b>EAHM-E10-TH-W29</b>
<b>Angle kit EAHM</b>				
	95, 120	For mounting the tubing holder on the connection block	<b>2075203</b>	<b>EAHM-E10-AK</b>
			<b>2075842</b>	<b>EAHM-E10-AK-P8<sup>1)</sup></b>

1) In combination with the variant EXPT-...P8

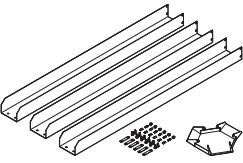
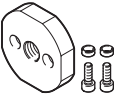
Ordering data				
	For size	Description	Part no.	Type
<b>Covering kit EASC-E10</b>				
	95	<ul style="list-style-type: none"> <li>Protects the working space against contamination by particles</li> <li>Can only be fitted in combination with the variant EXPT-...P8</li> </ul>	<b>3790894</b>	<b>EASC-E10-95</b>
	120		<b>3790896</b>	<b>EASC-E10-120</b>
<b>Adapter kit EAHA</b>				
	95, 120	For suction gripper ESG- (holder size 2)	<b>1574224</b>	<b>EAHA-R2-M12P</b>
		For suction gripper ESG- (holder size 3 and 4)	<b>1574227</b>	<b>EAHA-R2-M14P</b>

## Accessories

**Adapter kit**  
DHAA, HAPG

Material:  
Wrought aluminium alloy  
Free of copper and PTFE  
RoHS-compliant

 **Note**

The kit includes the individual mounting interface as well as the necessary mounting material.

Download CAD data → [www.festo.com](http://www.festo.com)

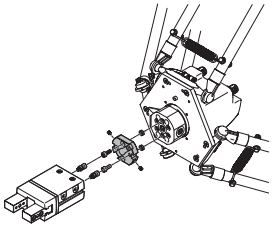
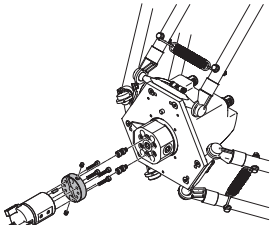
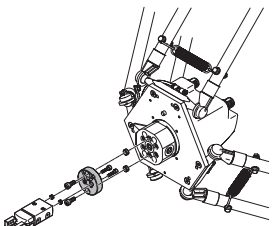
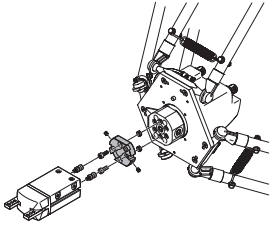
Gripper combinations with adapter kit			
Gripper	Size	Adapter kit	
		Part no.	Type
<b>Parallel gripper</b>			
	<b>DHPS, standard</b>		
	6	187566	HAPG-SD2-12
	10	184477	HAPG-SD2-1
	16	184478	HAPG-SD2-2
	<b>HGPT-B, heavy-duty</b>		
	16	564958	DHAA-G-Q5-12-B8-16
	20	564955	DHAA-G-Q5-16-B8-20
	25	537181	HAPG-SD2-25
	<b>HGPL, heavy-duty with long stroke</b>		
	14-40, 14-60, 14-80	537310	HAPG-SD2-31
	<b>HGPD, sealed</b>		
	16	564958	DHAA-G-Q5-12-B8-16
	20	564955	DHAA-G-Q5-16-B8-20
25	537181	HAPG-SD2-25	
<b>Three-point gripper</b>			
	<b>DHDS, standard</b>		
	16	187567	HAPG-SD2-13
	<b>HGDT, heavy-duty</b>		
25	542439	HAPG-SD2-32	
<b>Radial gripper</b>			
	<b>DHRS, standard</b>		
	10	187566	HAPG-SD2-12
	16	184477	HAPG-SD2-1
	25	184478	HAPG-SD2-2
	<b>HGRT, heavy-duty</b>		
16	1273999	DHAA-G-Q5-16-B11-16	
<b>Angle gripper</b>			
	<b>DHWS, standard</b>		
	10	187566	HAPG-SD2-12
	16	184477	HAPG-SD2-1
	25	184478	HAPG-SD2-2

# Festo - Your Partner in Automation



**1 Festo Inc.**  
5300 Explorer Drive  
Mississauga, ON L4W 5G4  
Canada

**Festo Customer Interaction Center**  
Tel: 1 877 463 3786  
Fax: 1 877 393 3786  
Email: [customer.service.ca@festo.com](mailto:customer.service.ca@festo.com)



**2 Festo Pneumatic**  
Av. Ceylán 3,  
Col. Tequesquináhuac  
54020 Tlalnepantla,  
Estado de México

**Multinational Contact Center**  
01 800 337 8669  
[ventas.mexico@festo.com](mailto:ventas.mexico@festo.com)



**3 Festo Corporation**  
1377 Motor Parkway  
Suite 310  
Islandia, NY 11749

**Festo Customer Interaction Center**  
1 800 993 3786  
1 800 963 3786  
[customer.service.us@festo.com](mailto:customer.service.us@festo.com)



**4 Regional Service Center**  
7777 Columbia Road  
Mason, OH 45040

Connect with us



[www.festo.com/socialmedia](http://www.festo.com/socialmedia)



[www.festo.com](http://www.festo.com)

Subject to change