

Linear gantries EXCT

FESTO

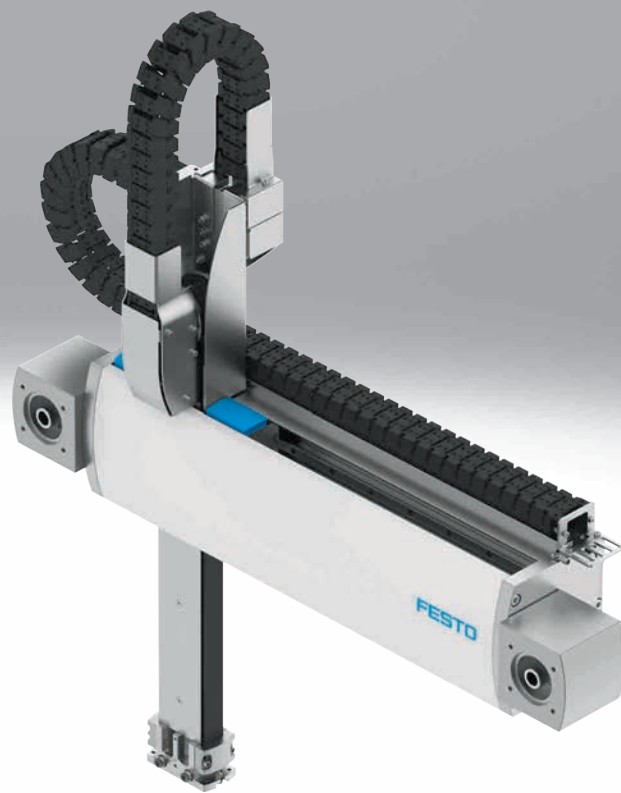

Key features

At a glance

General

- Optimal dynamic response when compared with other Cartesian gantry systems
- The drive concept ensures low moving dead weight
- Flat system design
- Flexible motor mountings
- High acceleration in both axis directions
- Interface for many grippers from Festo

Application examples

- Fast repositioning of parts and modules in a large, rectangular working space, e.g.:
 - Sorting
 - Loading, unloading
 - Gluing, cutting

Functional principle

Two fixed servo motors drive a toothed belt arranged in a T-shape. The toothed belt moves the slide of the Y-axis and the interface located on the Z-axis in a two-dimensional space. A controller calculates the position of the interface. The controlled interaction of the motors results in the movement of the interface. Attachment components enable additional processes to be carried out.

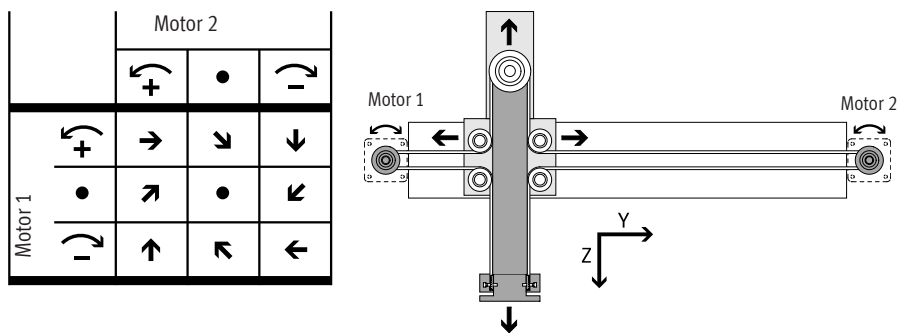

Note
Additional multi-axis controller required for interpolation (e.g. CPX-E-CEC-M1-...).

Type		EXCT-15	EXCT-30	EXCT-100
Guide		Recirculating ball bearing guide		
Stroke of the				
Y-axis	[mm]	100 ... 1000	100 ... 1500	100 ... 2000
Z-axis	[mm]	100, 200	250, 500	250, 500, 800
Rated load at max. dynamic response ¹⁾	[kg]	1.5	3	10
Repetition accuracy	[mm]	±0.1		

1) Rated load = tool load (attachment component + gripper, for example) + payload

Key features

Motor attachment variants

Sample product image,
motors not included in scope of delivery!

EXCT...-VV – Motor 1 at the front, motor 2 at the front

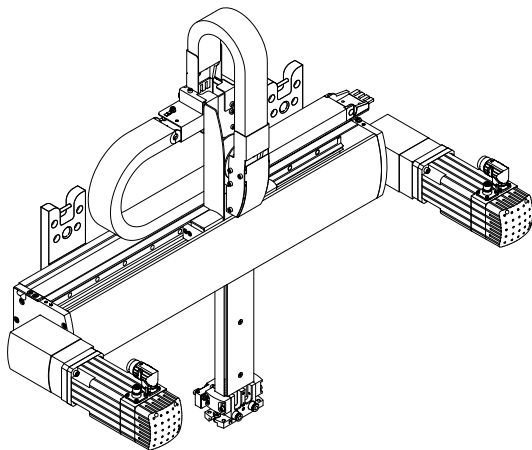

EXCT...-VH – Motor 1 at the front, motor 2 at the rear

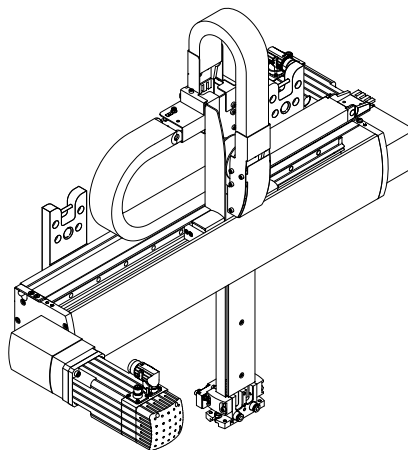

EXCT...-HV – Motor 1 at the rear, motor 2 at the front

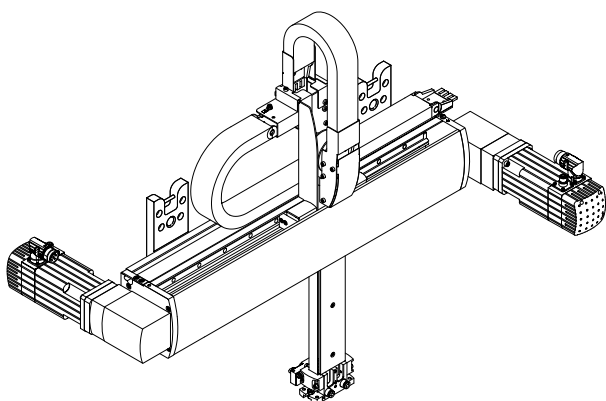

EXCT...-HH – Motor 1 at the rear, motor 2 at the rear

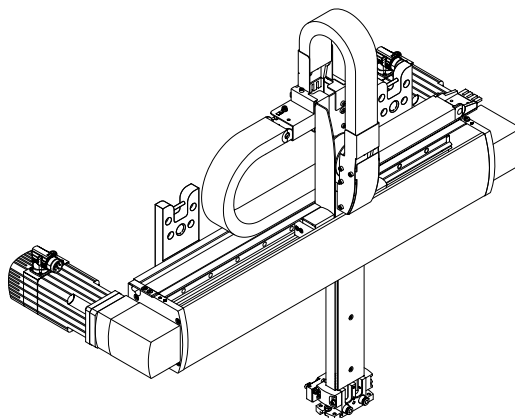

Mounting position

The linear gantry may only be mounted
and operated with a vertical Z-axis. The
interface for attachment components
must be positioned at the bottom.

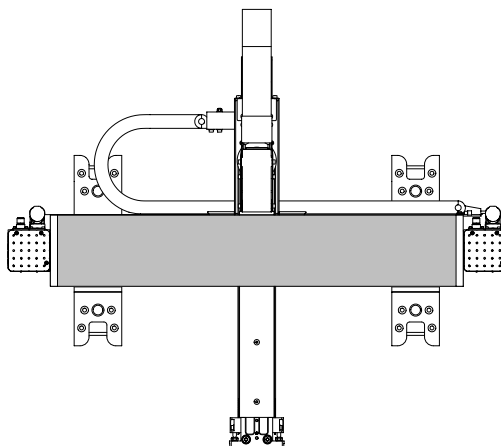

Key features

Mounting options

Using mounting kit EAHM-E17-K1-...

- For wall mounting
- No adjustment option following mounting

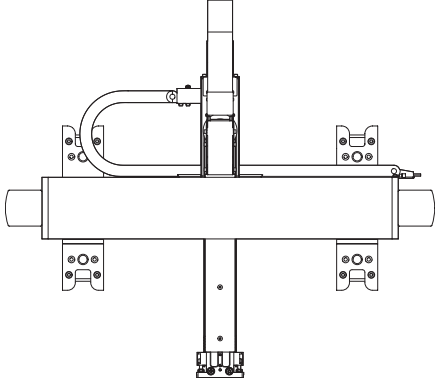

Using mounting kit EAHM-E17-K2-...

- For self-supported mounting
- Each side can be adjusted independently of each other in terms of height

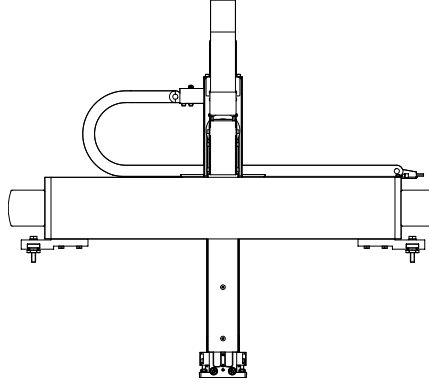

Mounting with slot nuts

- For mounting directly on the machine frame
- No adjustment option following mounting

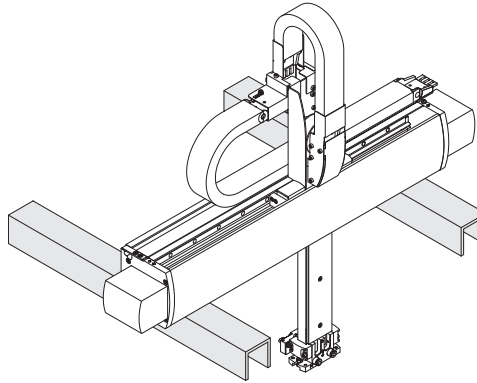
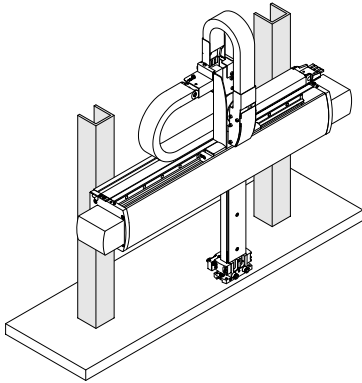

Type codes

001	Series
EXCT	Linear gantry

002	Size
15	15
30	30
100	100

003	Stroke of the Y-axis [mm]
50	50
2000	2000

004	Stroke of the Z-axis [mm]
100	100 mm
200	200 mm
250	250 mm
500	500 mm
800	800 mm

005	Guide
KF	Recirculating ball bearing guide

006	Motor type
W	Without motor

007	Motor attachment position
HH	Motor 1 at rear, motor 2 at rear
HV	Motor 1 at rear, motor 2 at front
VH	Motor 1 at front, motor 2 at rear
VV	Motor 1 at front, motor 2 at front

008	Energy chain connection side
L	Left
R	Right

009	Attachment components
T0	None

010	Cable length
	None

011	Installation
	None
MP1	Multi-pin distributor 4 x M8, with pneumatic lines

012	Document language
DE	German
EN	English
ES	Spanish
FR	French
IT	Italian
RU	Russian
ZH	Chinese

Peripherals overview

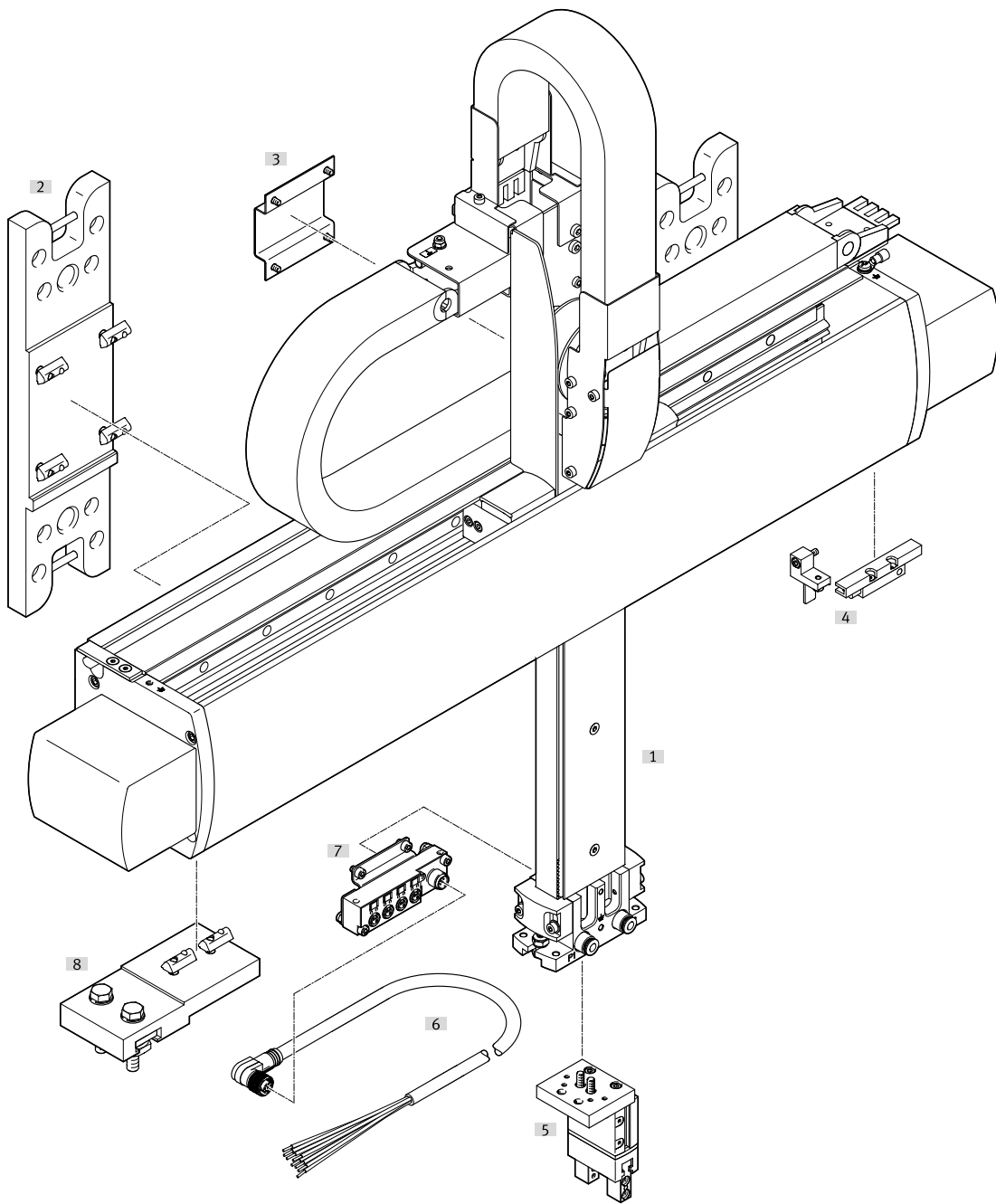

Peripherals overview

Attachments and accessories			
Type	Description		→ Page/Internet
[1] Linear gantry EXCT	–		8
[2] Mounting kit EAHM-E17-K1	<ul style="list-style-type: none"> • For wall mounting • Included in the scope of delivery of the linear gantry EXCT... 		22
[3] Adapter kit EAHM-E17-U	<ul style="list-style-type: none"> • For mounting valves, vacuum generators, etc. Mounting holes must be drilled by the customer • Not included in the scope of delivery of the linear gantry 		26
[4] Sensing kit EAPR-E17-S	<ul style="list-style-type: none"> • For position sensing on the Y-axis • Included in the scope of delivery: proximity switch SIES-Q8B, sensor bracket, switch lug, mounting bracket and screws • Not included in the scope of delivery of the linear gantry 		24
[5] Grippers	<ul style="list-style-type: none"> • A wide range of grippers is available 		28
[6] Plug socket with cable NEBU	<ul style="list-style-type: none"> • Connecting cable between multi-pin plug distributor and controller • Included in the scope of delivery of the linear gantry EXCT...-MP1; connected on delivery 		27
[7] Multi-pin set EADH-E17-MP1	<ul style="list-style-type: none"> • For connecting up to 4 inputs/outputs • Included in the scope of delivery of the linear gantry EXCT...-MP1 		25
[8] Mounting kit EAHM-E17-K2	<ul style="list-style-type: none"> • Height-adjustable mounting kit • Not included in the scope of delivery of the linear gantry 		23

Datasheet

Size
15, 30, 100



General technical data				
Size		15	30	100
Design		Linear gantry		
Guide		Recirculating ball bearing guide		
Stroke of the				
Y-axis	[mm]	100 ... 1000	100 ... 1500	100 ... 2000
Z-axis	[mm]	100, 200	250, 500	250, 500, 800
Rated load at max. dynamic response ¹⁾	[kg]	1.5	3	10
Max. process force in Z-direction	[N]	100	300	500
Max. torque ²⁾	[Nm]	7.75	12.5	22.1
Max. no-load torque ²⁾³⁾	[Nm]	0.51	1.28	2.56
Max. acceleration	[m/s ²]	50	50	30
Max. speed ⁴⁾	[m/s]	4.8	5	4
Repetition accuracy	[mm]	±0.1		
Mounting position		Vertical		
Type of mounting		With mounting kit and slot nuts		

1) Rated load = tool load (attachment component + gripper, for example) + payload

2) These values must also be complied with when installing third-party motors

3) At v=0.2 m/s and 45° travel.

4) This data applies only under ideal conditions.

For a precise configuration, please consult a sales engineer from Festo.

Operating and environmental conditions				
Size		15	30	100
Degree of protection		IP40		
Operating pressure ¹⁾	[bar]	-0.95 ... +8		
Operating medium		Compressed air to 8573-1:2010 [7:4:4]		
Note on operating and pilot medium		Lubricated operation possible (in which case lubricated operation will always be required)		
Ambient temperature ²⁾	[°C]	+10 ... +40		
Storage temperature	[°C]	-10 ... +60		
Relative humidity	[%]	0 ... 90 (non-condensing)		
Noise level	[dB(A)]	70	78	77
Duty cycle	[%]	100		

1) Permissible operating pressure for ports P1 and P2

2) Note operating range of proximity switches and motors

Datasheet

Materials

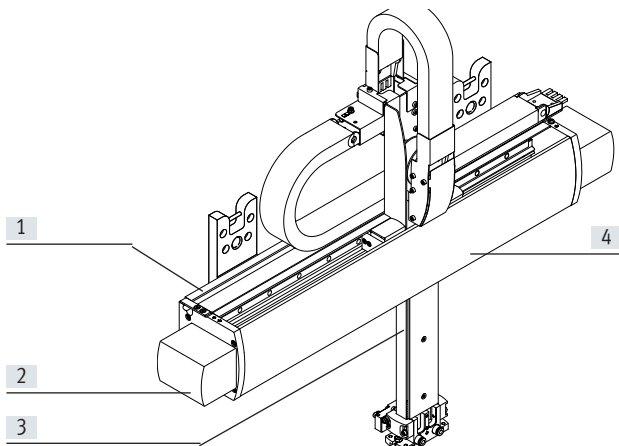

Size	15	30	100
[1] Profile of the Y-axis	Anodised aluminium		
[2] Actuator housing	Anodised aluminium		
[3] Profile of the Z-axis	Anodised aluminium		
[4] Covering	Anodised aluminium		
- Guide	High-alloy steel		
- Ball bearings	Steel		
- Toothed belt	PU with steel cord		
Note on materials	RoHS-compliant		
	Contains paint-wetting impairment substances		

Weight [kg]			
Size	15	30	100
Product weight at 0 mm stroke (without rated load, motors, axial kits, mounting kits)			
Y/Z-axis	12.1	25.38	31.65
Additional weight per 100 mm stroke			
Y-axis	0.95	1.48	1.86
Z-axis	0.32	0.37	0.39
Multi-pin plug distributor	0.1	0.1	0.1

Toothed belt			
Size	15	30	100
Pitch [mm]	3	5	5
Elongation [%]	0.05	0.045	0.075
Reference force for elongation [N]	100	300	500
Width [mm]	20	30	30
Effective diameter [mm]	28.65	31.82	39.79
Feed constant ¹⁾ [mm/rev]	90	100	125

1) Feed constant at 45° travel

Note

Engineering software
 Handling Guide Online
www.festo.com/handling-guide

Datasheet

Max. acceleration a in Y-direction as a function of rated load m_L , Z-axis stroke l and position of Z-axis lp

EXCT-15

Z-axis stroke $l = 100$ mm

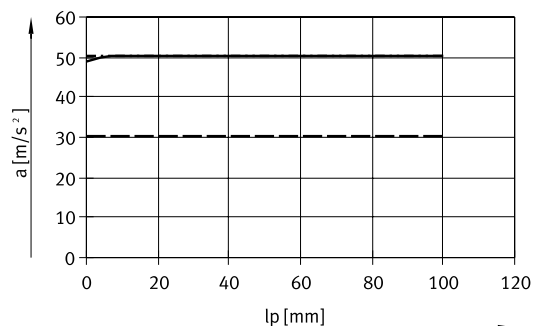

- Rated load $m_L = 0$ kg
- ⋯ Rated load $m_L = 1.5$ kg
- - - Rated load $m_L = 3$ kg

Z-axis stroke $l = 200$ mm

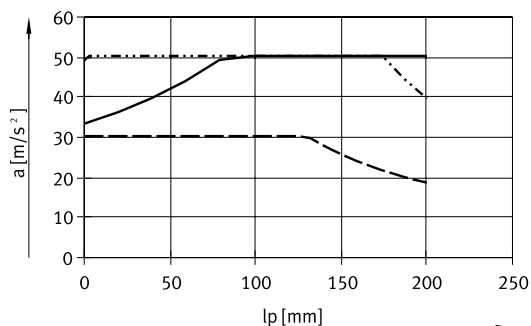

- Rated load $m_L = 0$ kg
- ⋯ Rated load $m_L = 1.5$ kg
- - - Rated load $m_L = 3$ kg

EXCT-30

Z-axis stroke $l = 250$ mm

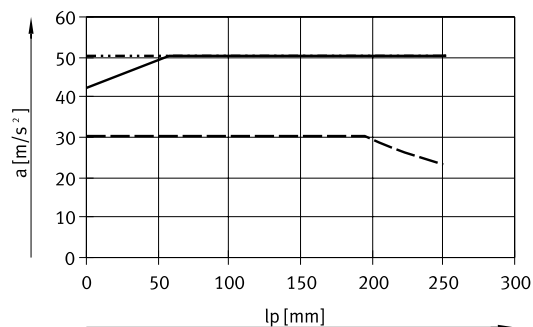

- Rated load $m_L = 0$ kg
- ⋯ Rated load $m_L = 3$ kg
- - - Rated load $m_L = 6$ kg

Z-axis stroke $l = 500$ mm

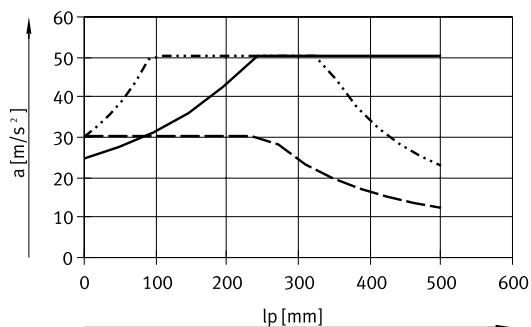

- Rated load $m_L = 0$ kg
- ⋯ Rated load $m_L = 3$ kg
- - - Rated load $m_L = 6$ kg

EXCT-100

Z-axis stroke $l = 250$ mm

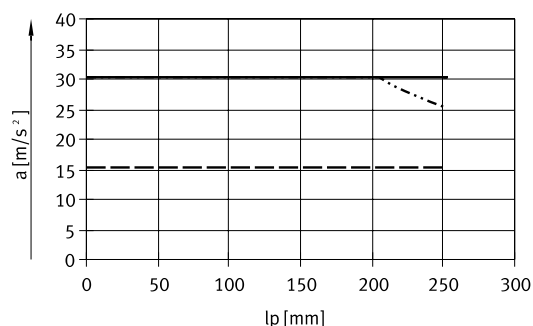

- Rated load $m_L = 0$ kg
- ⋯ Rated load $m_L = 10$ kg
- - - Rated load $m_L = 15$ kg

Z-axis stroke $l = 500$ mm

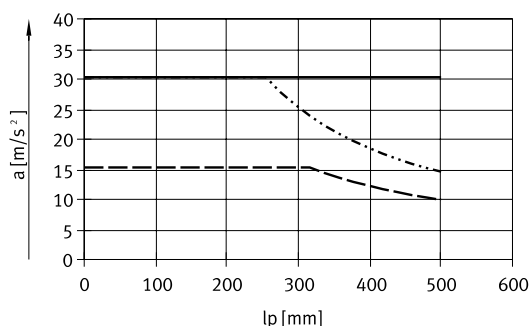

- Rated load $m_L = 0$ kg
- ⋯ Rated load $m_L = 10$ kg
- - - Rated load $m_L = 15$ kg

Datasheet

Max. acceleration a in Y-direction as a function of rated load m_L , Z-axis stroke l and position of Z-axis lp

EXCT-100

Z-axis stroke $l = 800$ mm

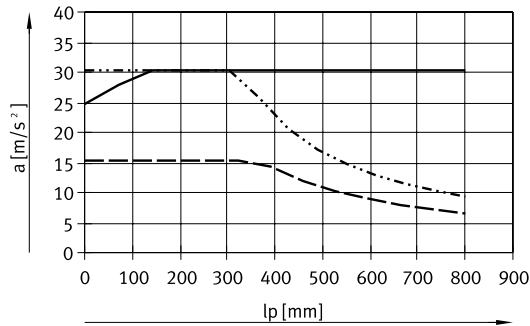

- Rated load $m_L = 0$ kg
- ⋯ Rated load $m_L = 10$ kg
- - - Rated load $m_L = 15$ kg

Friction torque M as a function of velocity v

EXCT-15

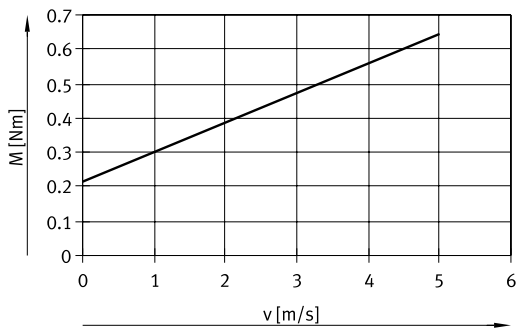

EXCT-30

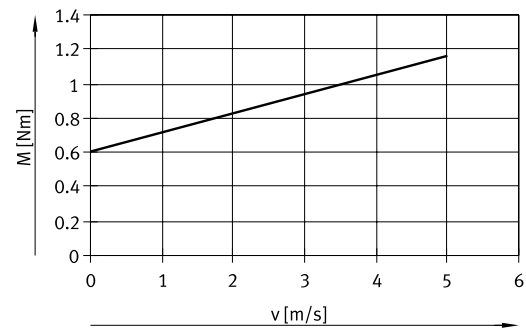

EXCT-100

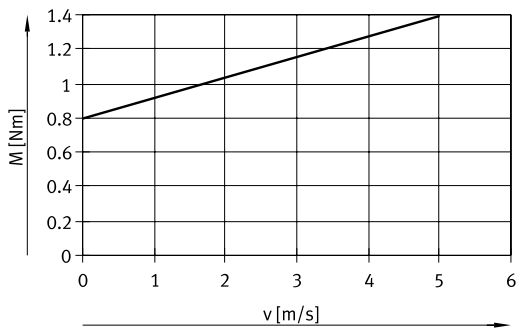

Datasheet

Load values

The system is subject to the greatest load in the case of 45° travel.
The following data apply in this case:

Formula for calculating the required torque M and the required nominal rotational speed n

For EXCT-15:

$$n_{45^\circ} = 60000 / \text{feed constant(mm)} \times \text{sqrt}(2)$$

and Z-axis stroke = 100 mm:

$$M_{45^\circ} = a \times (10.1 \times m_L + 9.87 \times J_m + 44.4) \times 10^{-3} + 0.07 \times (2.3 + m_L) + M_R$$

and Z-axis stroke = 200 mm:

$$M_{45^\circ} = a \times (10.1 \times m_L + 9.87 \times J_m + 47.5) \times 10^{-3} + 0.07 \times (2.6 + m_L) + M_R$$

For EXCT-30:

$$n_{45^\circ} = 60000 / \text{feed constant(mm)} \times \text{sqrt}(2)$$

and Z-axis stroke = 250 mm:

$$M_{45^\circ} = a \times (11.3 \times m_L + 8.89 \times J_m + 99.1) \times 10^{-3} + 0.08 \times (4.7 + m_L) + M_R$$

and Z-axis stroke = 500 mm:

$$M_{45^\circ} = a \times (11.3 \times m_L + 8.89 \times J_m + 108.1) \times 10^{-3} + 0.08 \times (5.5 + m_L) + M_R$$

For EXCT-100:

$$n_{45^\circ} = 60000 / \text{feed constant(mm)} \times \text{sqrt}(2)$$

and Z-axis stroke = 250 mm:

$$M_{45^\circ} = a \times (14.1 \times m_L + 7.11 \times J_m + 164.4) \times 10^{-3} + 0.098 \times (6 + m_L) + M_R$$

and Z-axis stroke = 500 mm:

$$M_{45^\circ} = a \times (14.1 \times m_L + 7.11 \times J_m + 178.3) \times 10^{-3} + 0.098 \times (7 + m_L) + M_R$$

and Z-axis stroke = 800 mm:

$$M_{45^\circ} = a \times (14.1 \times m_L + 7.11 \times J_m + 193.8) \times 10^{-3} + 0.098 \times (8.1 + m_L) + M_R$$

a = acceleration [m/s²]

v = speed [m/s]

m_L = attachment component (Z-axis) [kg] with payload

J_m = moment of inertia of the motor [kgcm²]

M_R = friction torque [Nm] → page 11

n_{45°} = nominal rotational speed at 45° travel [rpm]

Datasheet

Sample calculation

1. What is the max. load permitted by the mechanical system?

Assuming:

EXCT-15-500-200-KF-W-VV-...

$a_{max.} = 20 \text{ m/s}^2$

$v_{max.} = 2 \text{ m/s}$

Rated load $m_L = 3 \text{ kg}$ (gripper + workpiece)

Position of Z-axis = 70 mm (at max. acceleration in Y-direction)

Calculation:

1. What is the max. acceleration permitted by the mechanical system?

Rated load $m_L = 3 \text{ kg}$

Z-axis stroke = 200 mm

Position of Z-axis = 150 mm

From the graph:

$a = \text{approx. } 26 \text{ m/s}^2$

Results:

With a moving mass of 3 kg and a position of the Z-axis of 150 mm, the max. permissible acceleration in the Y-direction is 26 m/s^2 .

The required acceleration of 20 m/s^2 is thus permissible.

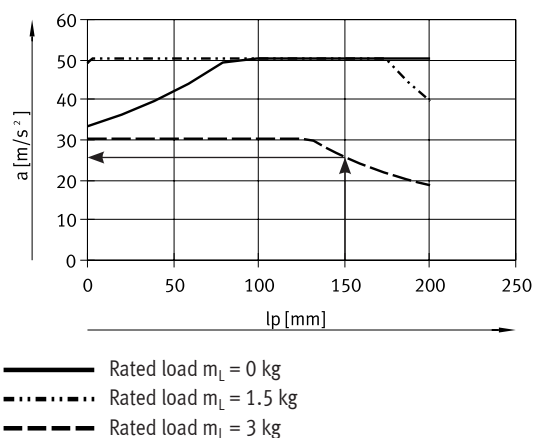

Datasheet

Sample calculation

2. Is the envisaged motor sufficient for this load?

Assuming:

$$a_{\max.} = 20 \text{ m/s}^2$$

$$v_{\max.} = 2 \text{ m/s}$$

Rated load $m_L = 3 \text{ kg}$ (gripper + workpiece)

$$J_m = 0.680 \text{ kgcm}^2$$

$$M_{45^\circ} = a \times (10.1 \times m_L + 9.87 \times J_m + 39.2) \times 10^{-3} + 0.07 \times (2.14 + m_L) + M_R$$

$$n_{45^\circ} = 60000 / \text{feed constant(mm)} \times \text{sqrt}(2)$$

Determining M_{45° :

$$n_{45^\circ} = 60000 / \text{feed constant(mm)} \times \text{sqrt}(2)$$

a = acceleration [m/s^2]

v = speed [m/s]

m_L = attachment component (Z-axis) [kg] with payload

J_m = moment of inertia of the motor [kgcm^2]

M_R = friction torque [Nm] → page 11

n_{45° = nominal rotational speed at 45° travel [rpm]

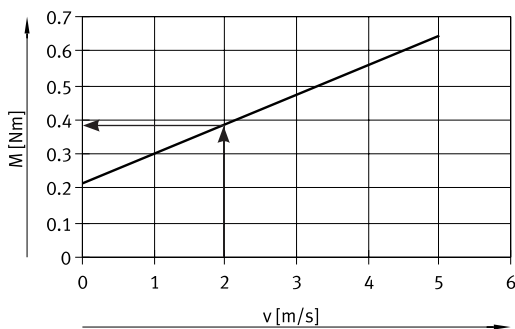

$$M_R = 0.38 \text{ Nm}$$

$$M_{45^\circ} = a \times (10.1 \times m_L + 9.87 \times J_m + 39.2) \times 10^{-3} + 0.07 \times (2.14 + m_L) + M_R$$

$$M_{45^\circ} = 20 \text{ m/s}^2 \times (10.1 \times 3 \text{ kg} + 9.87 \times 0.680 \text{ kgcm}^2 + 39.2) \times 10^{-3} + 0.07 \times (2.14 + 3 \text{ kg}) + 0.38 \text{ Nm} = 2.26 \text{ Nm}$$

Results:

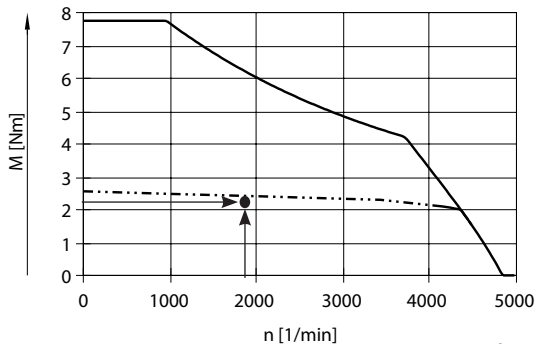

— Max. torque

- - - - - Nominal torque

Sample motor/servo drive characteristic!

Results:

The value for the torque is just below the nominal torque.

This torque is only required in the acceleration phases.

The design is thus acceptable.

Datasheet

Maximum permissible support span

In order to limit deflection in the case of large stroke lengths, the axis may need to be supported. An additional mounting kit is therefore required for strokes greater than $L = 1500$ mm.

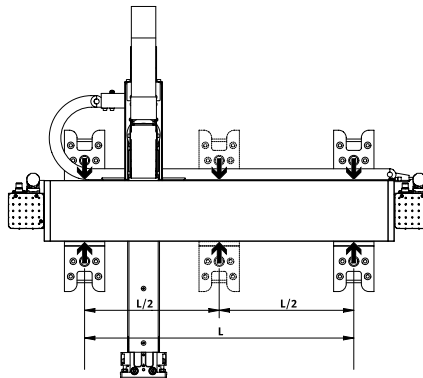

Recommended deflection limits

To avoid impairing the functionality of the gantry, we recommend that the following deflection limits are observed. Greater deformation can result in increased friction, greater wear and reduced service life.

Size	15	30	100
Dynamic deflection (load is moving)	0.03% ¹⁾	0.03% ¹⁾	0.03% ¹⁾
	Max. 0.3 mm	Max. 0.45 mm	Max. 0.6 mm
Static deflection (stationary load)	0.05% ¹⁾	0.05% ¹⁾	0.05% ¹⁾

1) Of the length of the axis

Energy routing

- The cables are routed from the cable outlet to the Z-axis using energy chains [2]
- When ordering the linear gantry it is possible to select whether the cable outlet to the control cabinet [1] should be to the left or the right
- The cables are routed within the Z-axis [6] as far as the interface. At the interface, there are two permanent compressed air supply ports [7].
- The tubing and cables that project from the output of the energy chain at the Y-axis [5] are at least 10 m in length.

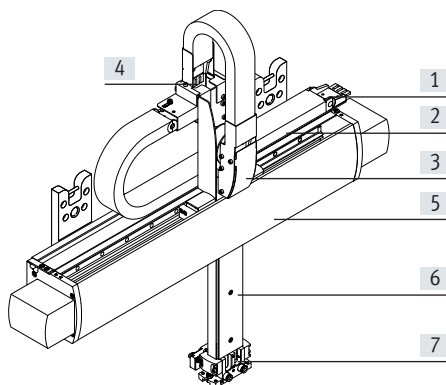

- [1] Cable outlet to the control cabinet
- [2] Energy chain
- [3] Transfer to the Z-axis
- [4] Transfer of the two energy chains
- [5] Y-axis
- [6] Z-axis
- [7] Interface with compressed air supply ports

Datasheet

Dimensions

Download CAD data → www.festo.com

Linear gantry

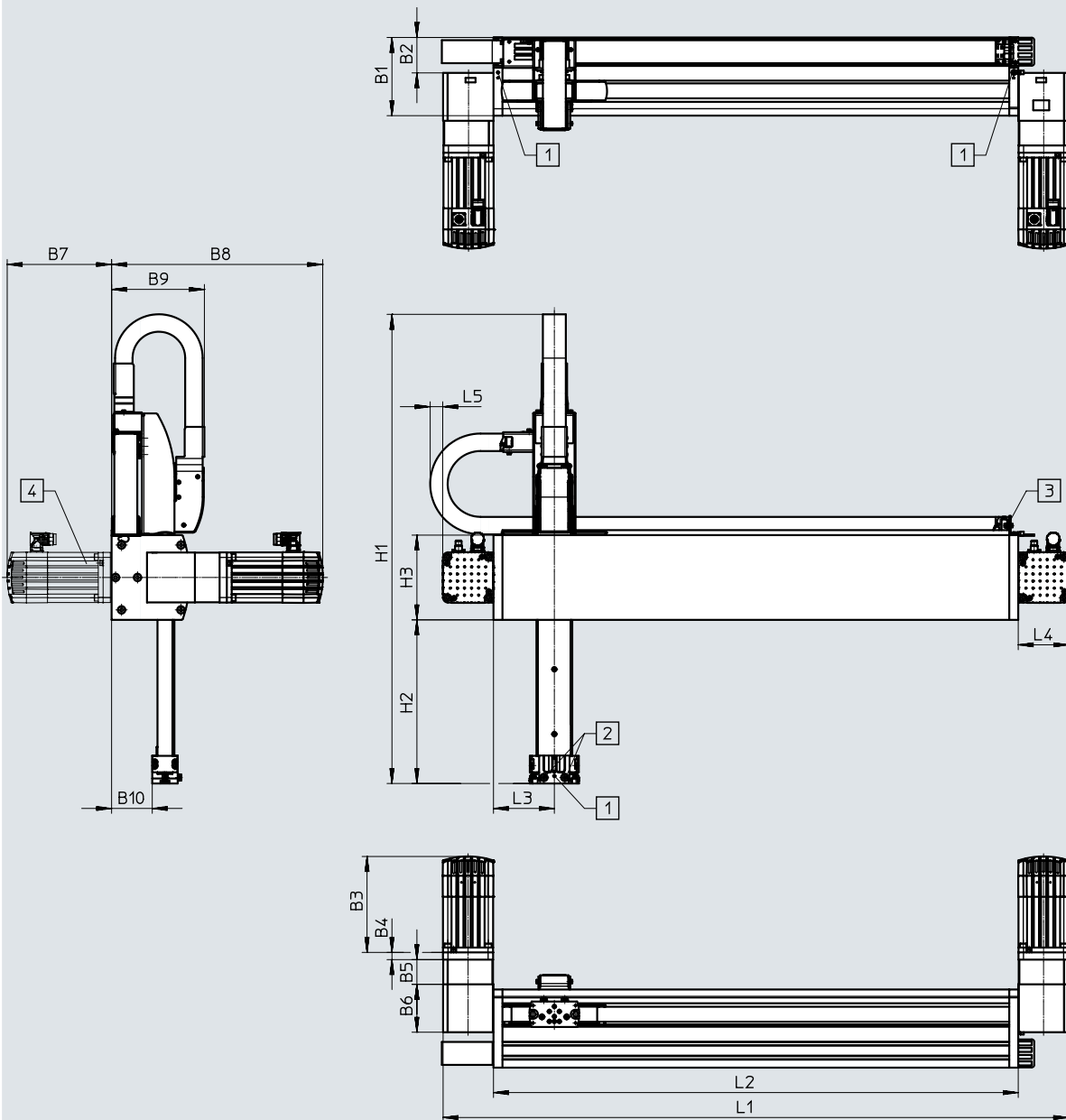

- [1] Earthing connection
- [2] Working air ports P1 and P2
- [3] Cable outlet to the control cabinet on the right

Datasheet

Size	B1	B2	B6	B9	B10	H3	L4	L5
15	121	57.6	89	138.1	66	120	71	25
30	157	71	96	186	81.5	170	102	25
100	184	94	123	211	106.5	200	102	25

Stroke-dependent dimensions

Size	Stroke of the Y-axis	L1	L2	L3
15	100 ... 1000	336+stroke	194+stroke	94+software end positions
30	100 ... 1500	456+stroke	252+stroke	122+software end positions
100	100 ... 2000	468+stroke	264+stroke	128+software end positions

Size	Z-axis stroke	H1	H2
15	100	636	170
	200	736	270
	Stroke	536+stroke	70+stroke
30	250	942	328
	500	1192	578
	Stroke	692+stroke	78+stroke
100	250	991	336
	500	1241	586
	800	1541	886
	Stroke	741+stroke	86+stroke

Note
 Requirements for the flatness of the bearing surface and for attachments
 → www.festo.com/sp User documentation

Factoring in software end positions

When selecting the strokes for the Y- and Z-axis, the dimension L3 for the software end positions must be factored into the working stroke L2. This dimension is freely selectable. An adjusting piece with L3 = 30 mm is included in the scope of delivery of the linear gantry.

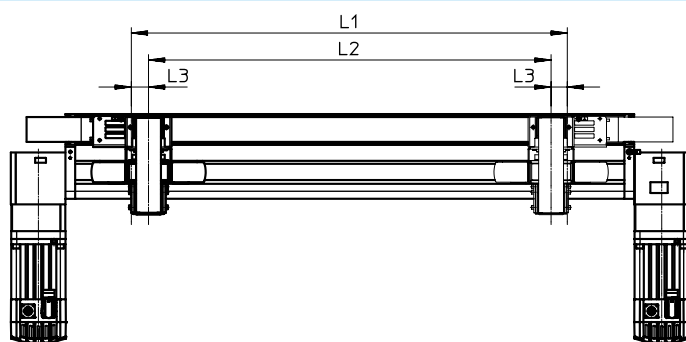

Stroke L1 = working stroke L2 + 2x software end position L3

Datasheet

Dimensions

Download CAD data → www.festo.com

Interface of attachment component with compressed air supply ports P1 and P2

EXCT-15/-30

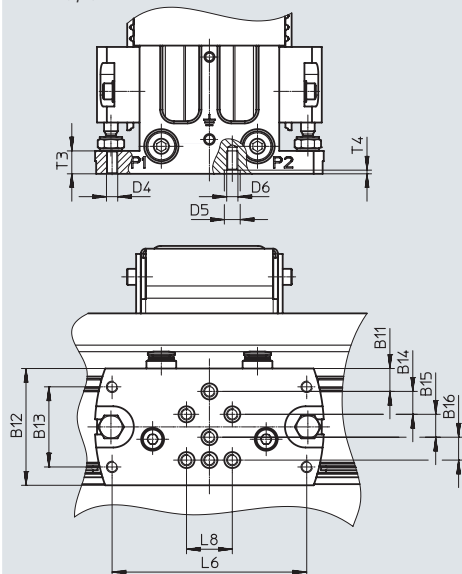

EXCT-100

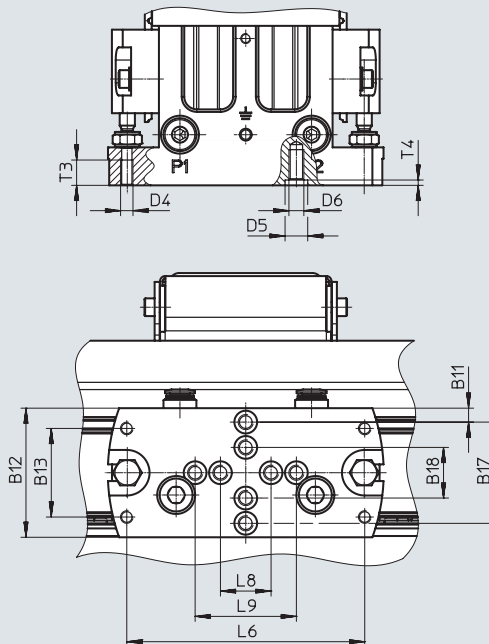

Tubing with an outside diameter of 6 mm can be connected to ports P1 and P2.

For size	B11	B12	B13	B14	B15	B16	B17	B18
15	5	41	31	10	10	10	-	-
30	10	51	35	10	10	10	-	-
100	5.5	51	35	-	-	-	40	20

For size	D4	D5 ∅ H7	D6	L6	L8	L9	T3	T4
15	M5	7	M5	76	20	-	10	1.6
30	M5	7	M5	85	20	-	10	1.6
100	M5	9	M6	94	20	40	15	2.1

Datasheet

Dimensions

Download CAD data → www.festo.com

Motor interface

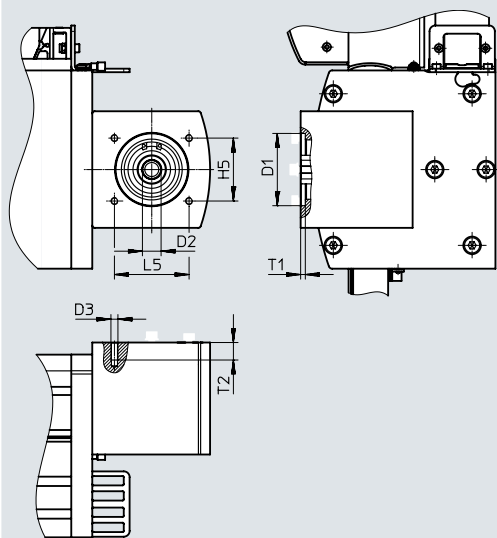

For size	D1 ∅ +0.05	D2 ∅ H7	D3	H5	L5	T1	T2
15	48	16	M5	35	46	4	15
30	62	16	M6	54	64	4	15
100	72	23	M6	54	64	4	15

Ordering data – Modular product system

Ordering table						
Size	15	30	100	Conditions	Code	Enter code
Module no.	8026575	8026576	8026577			
Product type	Series T				EXCT	EXCT
Size	15	30	100		-...	
Stroke of the Y-axis [mm]	100 ... 1000	100 ... 1500	100 ... 2000		-...	
Z-axis stroke [mm]	100, 200	250, 500	250, 500, 800		-...	
Guide	Recirculating ball bearing guide				-KF	-KF
Motor type	Without motor				-W	
Motor attachment position	Motor 1 at the rear, motor 2 at the rear				-HH	
	Motor 1 at the rear, motor 2 at the front				-HV	
	Motor 1 at the front, motor 2 at the rear				-VH	
	Motor 1 at the front, motor 2 at the front				-VV	
Connection side for the energy chain	To the left				-L	
	To the right				-R	
Attachment components (front unit)	None				-TO	-TO
Cable length	None					
Installation	None					
	Multi-pin plug distributor 4 x M8, with pneumatic cables				-MP1	
Document language	German				-DE	
	English				-EN	
	Spanish				-ES	
	French				-FR	
	Italian				-IT	
	Russian				-RU	
	Chinese				-ZH	

Accessories

 **Note**

Depending on the combination of motor and drive, it may not be possible to reach the maximum feed force of the drive.

Third-party motors that have an overly high driving torque may damage the linear gantry. When selecting the motors, please observe the limits specified in the technical data.

Permissible axis/motor combinations with axial kit

Datasheets → Internet: eamm-a

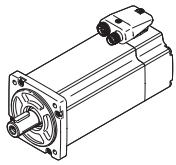
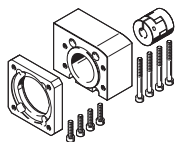
Motor / gear unit ¹⁾	Axial kit	
		• Kits for third-party motors → Internet: eamm-a
Type	Part no.	Type
EXCT-15		
With servo motor		
EMMT-AS-80-...	8164277	EAMM-A-L48-80P-G2
EXCT-30		
With servo motor		
EMMT-AS-100-...	8164409	EAMM-A-Y62-100A
EXCT-100		
With servo motor		
EMMT-AS-100-...	8164276	EAMM-A-L62-100A-G2

1) The input torque must not exceed the max. permissible transferable torque of the axial kit.

Ordering data

Coupling	For axial kit	Part no.	Type
	EAMM-A-L48-80P-G2	558002	EAMD-42-40-19-16X25
	EAMM-A-Y62-100A	558002	EAMD-42-40-19-16X25
	EAMM-A-L62-100A-G2	558003	EAMD-56-46-19-23X27

Ordering data

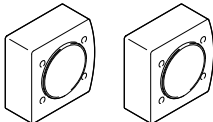
	Description	For size	Possible screws	Tightening torque [Nm]	Part no.	Type	PU ¹⁾
Coupling housing EAMK-A-E17²⁾							
	For connecting third-party motors	15	ISO 4762-M5xn ³⁾	6	3780303	EAMK-A-E17-15	2
		30	ISO 4762-M6xn ³⁾	8.5	3780304	EAMK-A-E17-30	
		100	ISO 4762-M6xn ³⁾	8.5	3780305	EAMK-A-E17-100	

1) Packaging unit.

2) Retaining screws are not included in the scope of delivery

3) The length n must be determined as a function of the motor flange used

Accessories

Mounting kit
EAHM-E17-K1

For wall mounting

Material:
Wrought aluminium alloy

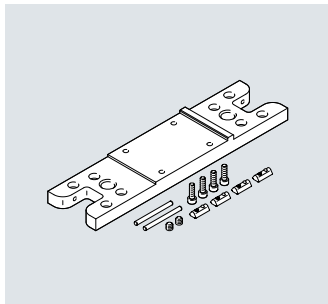

EXCT-15

EXCT-30/100

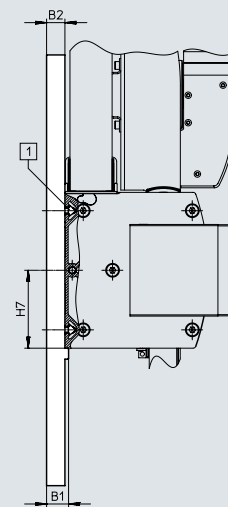
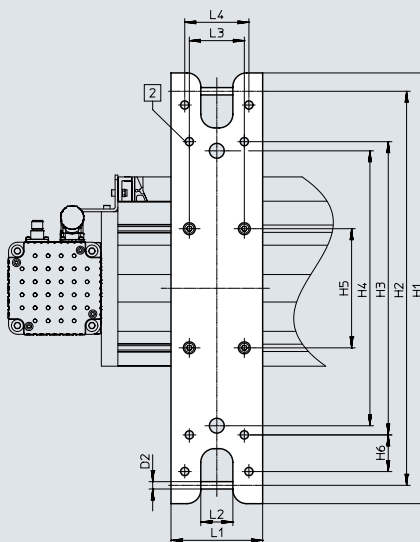
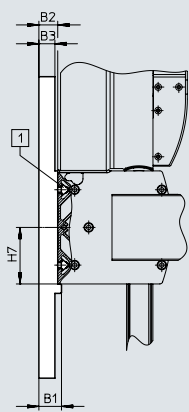
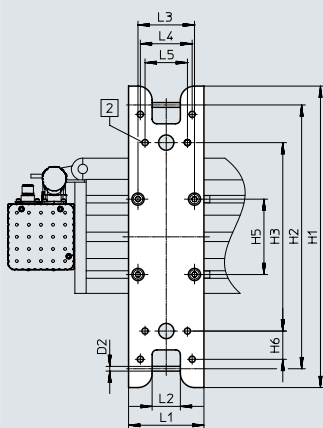

- [1] Screw ISO 4762 M6x20
- [2] With EXCT-15:
for screw ISO 4762 M6
- With EXCT-30/-100:
for screw ISO 4762 M8

Dimensions and ordering data

For size	B1	B2	B3	D2 Ø	H1	H2	H3	H4	H5	H6	H7
15	24	20	17	5	320	280	200	–	80	30	60
30	24	20	–	8	470	430	320	300	130	40	85
100	24	20	–	8	470	430	320	300	160	40	100

For size	L1	L2	L3	L4	L5	Weight [g]	Part no.	Type
15	80	30	60	55	45	1150	3995047	EAHM-E17-K1-15
30	100	35	60	70	–	2350	3823208	EAHM-E17-K1-30
100	100	35	60	70	–	2350	4055845	EAHM-E17-K1-100

Accessories

Mounting kit

EAHM-E17-K2

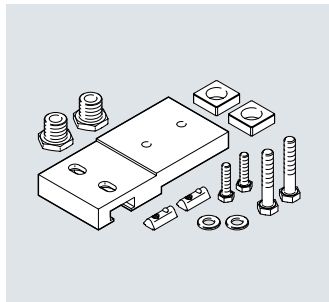

For mounting and aligning on a bearing surface.

The kit is height-adjustable

Material:
Galvanised steel

EXCT-15

EXCT-30/100

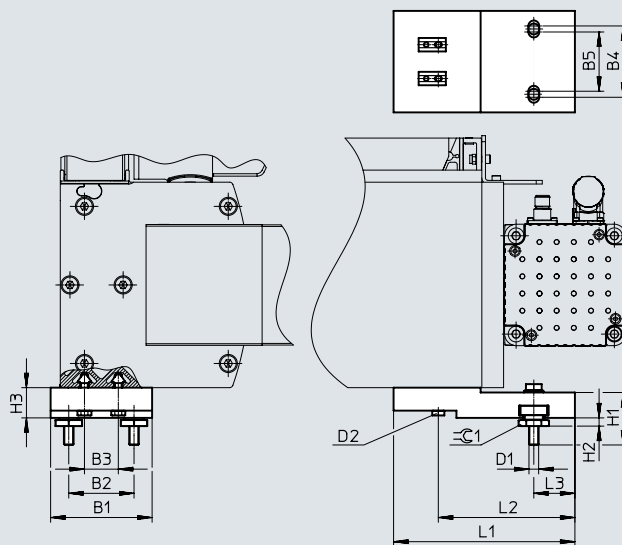
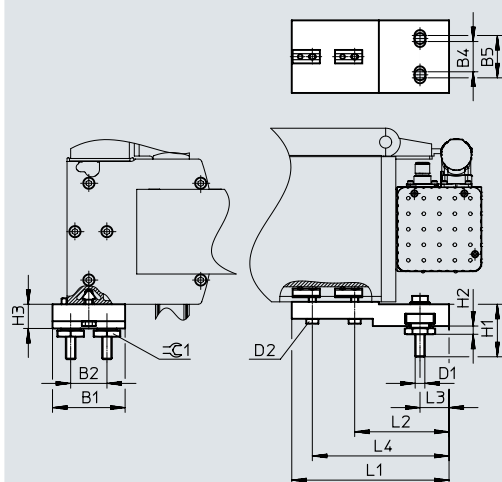

Dimensions and ordering data

For size	B1	B2	B3	B4	B5	D1	D2	H1	H2 +3	H3
15	60	30	-	25	35	M8	M6	43.4	6.8	20
30	84	54	28	49	59	M8	M6	43.4	6.8	25
100	110	70	50	65	75	M8	M6	43.4	6.8	25

For size	L1	L2	L3	L4	⌀1	Weight [g]	Part no.	Type
15	130	78	24	113	22	1015	3838164	EAHM-E17-K2-15
30	150	113	34	-	22	2050	3838337	EAHM-E17-K2-30
100	170	133	29	-	22	3000	3838404	EAHM-E17-K2-100

Accessories

Sensing kit

EAPR-E17-S

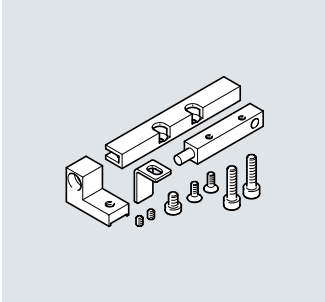

Included in the scope of delivery:
Proximity switch SIES-Q8B, sensor
bracket, switch lug, mounting bracket
and screws

Material:
Switch lug: Steel
Sensor bracket: Wrought aluminium al-
loy

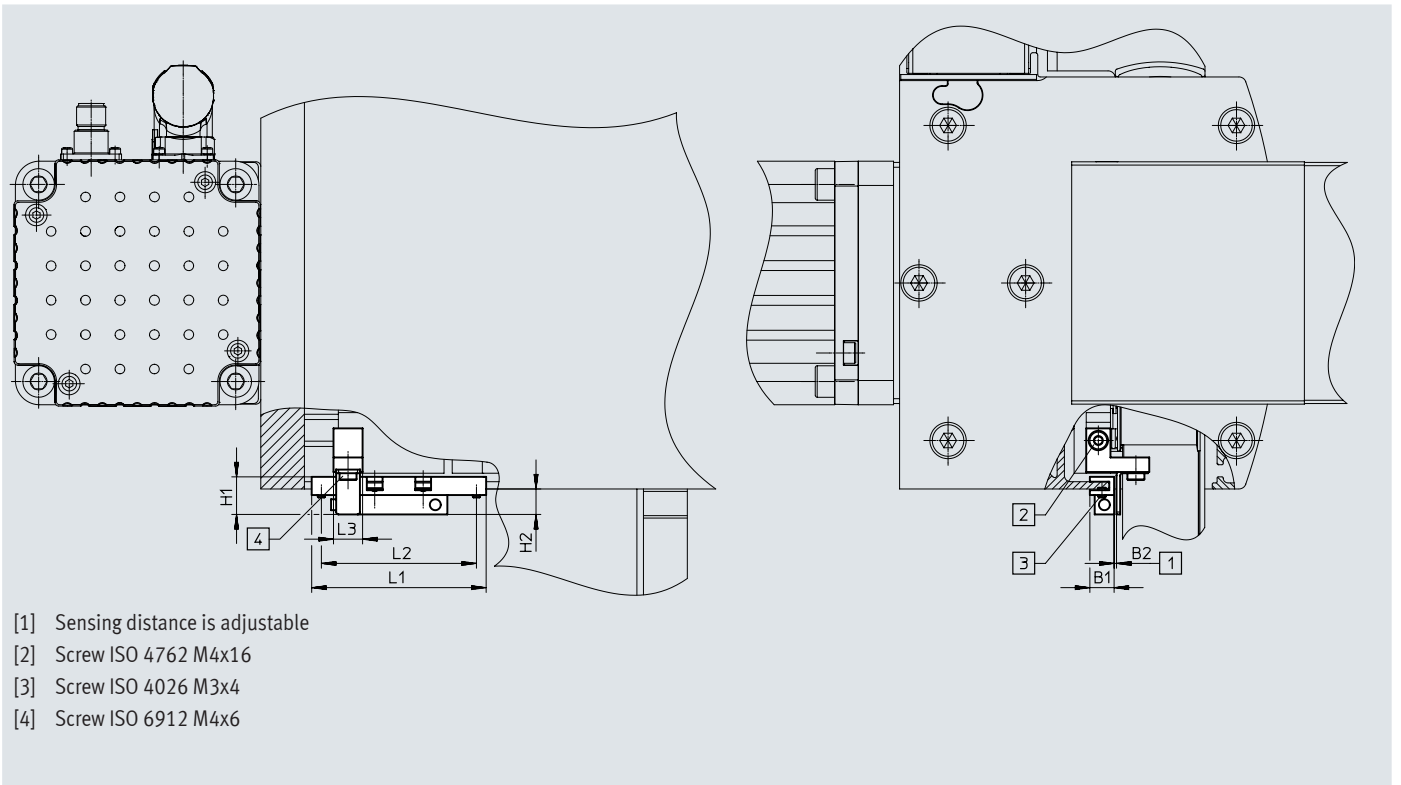

- [1] Sensing distance is adjustable
- [2] Screw ISO 4762 M4x16
- [3] Screw ISO 4026 M3x4
- [4] Screw ISO 6912 M4x6

Dimensions and ordering data

For size	B1	B2	H1	H2	L1	L2	L3	Weight [g]
15, 30, 100	10	1	15.5	10.5	72	64	12	30

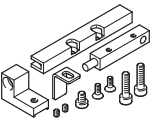
Designation	Description	Part no.	Type
	<ul style="list-style-type: none"> • For size 15, 30, 100 • Included in the scope of delivery: proximity switch SIES-Q8B, sensor bracket, switch lug, mounting bracket and screws 	PNP, N/C contact	8092368 EAPR-E17-S1
		PNP, N/O contact	2478427 EAPR-E17-S
		NPN, N/C contact	8092369 EAPR-E17-S3
		NPN, N/O contact	8092370 EAPR-E17-S4

Accessories

Multi-pin set EADH-E17

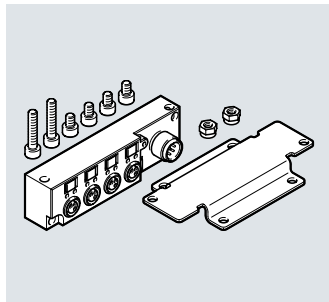

For connecting up to 4 inputs/outputs

Material:
Housing: PBT reinforced
Retaining bracket: aluminium

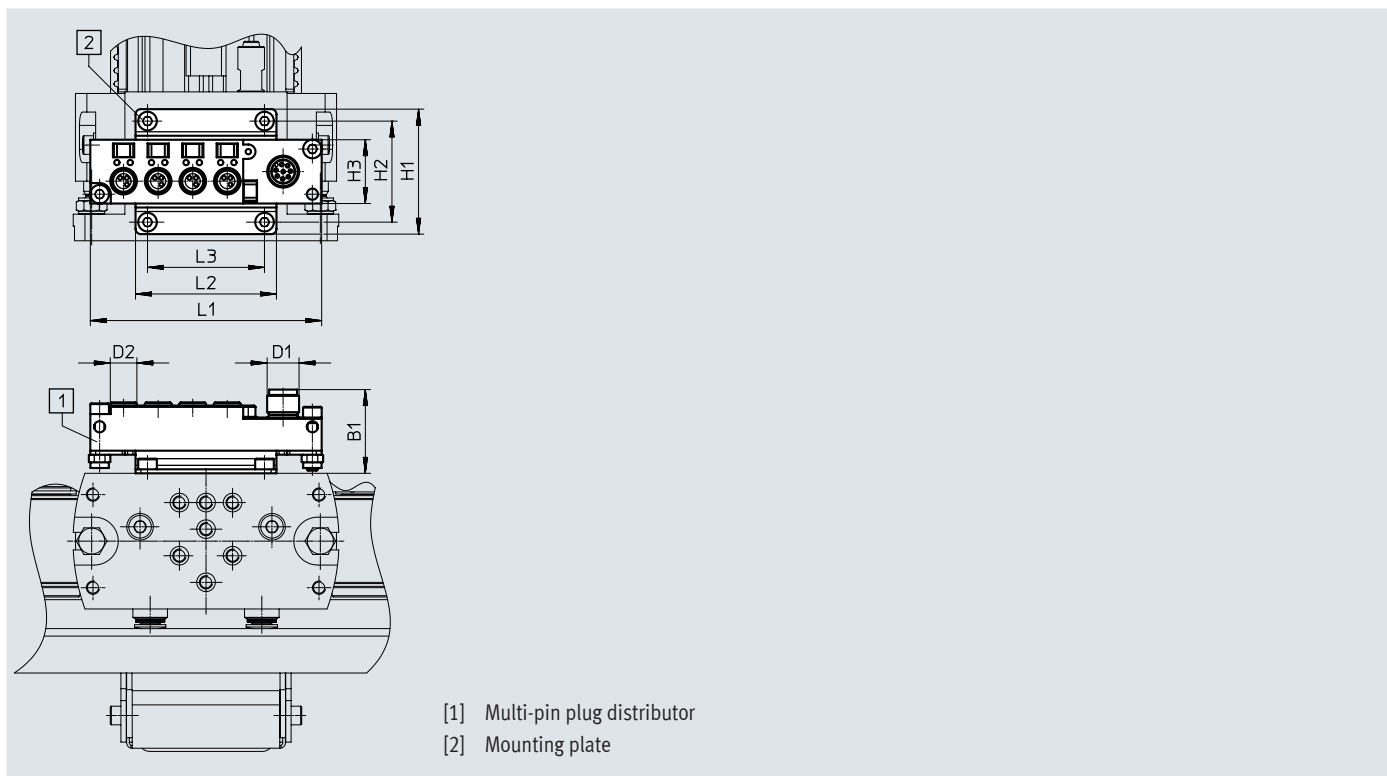

- [1] Multi-pin plug distributor
- [2] Mounting plate

Dimensions and ordering data												
For size	B1	D1	D2	H1	H2	H3	L1	L2	L3	Weight [g]	Part no.	Type
15, 30, 100	31.5	M12	M8	47	38	24	87	53	44	70	2972137	EADH-E17-MP1

Accessories

Adapter kit
EAHM-E17

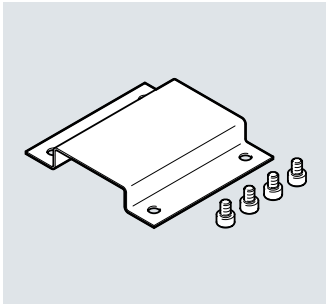

For mounting valves, vacuum generators, etc., on the Z-axis

Material:
Stainless steel

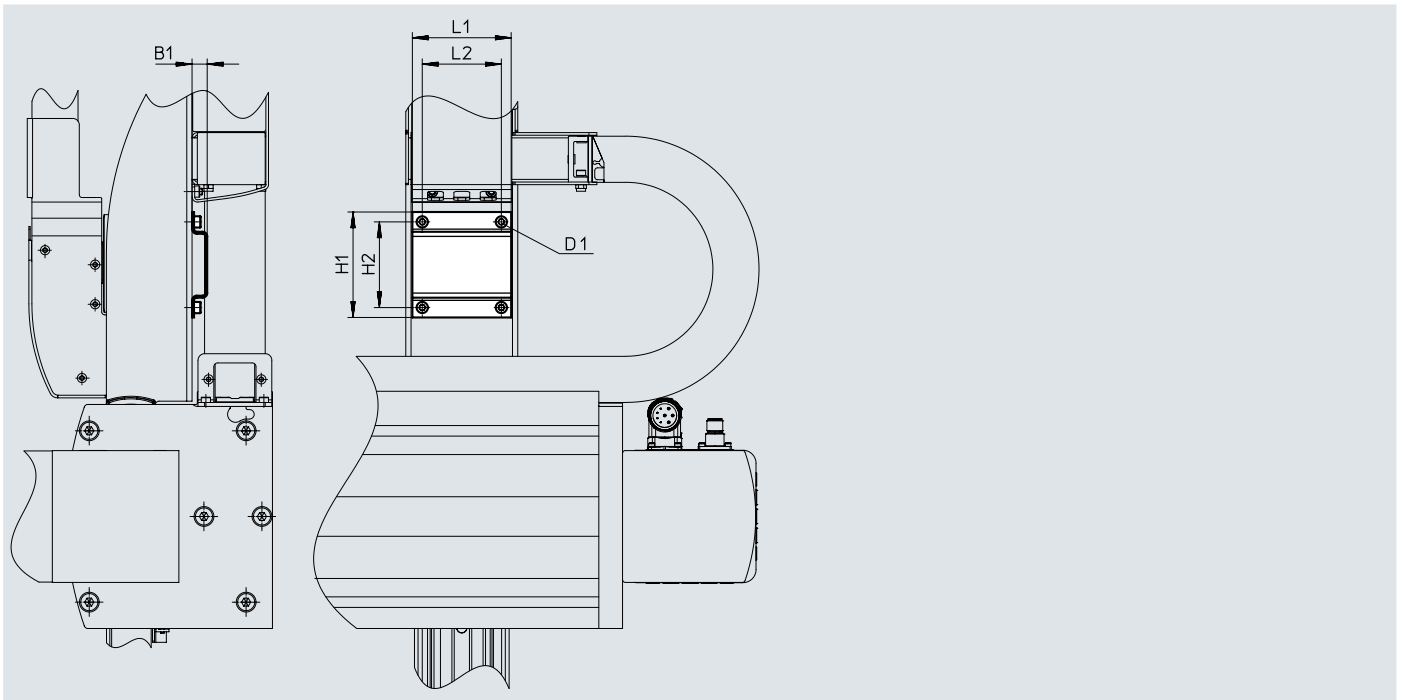

Dimensions and ordering data

For size	B1	D1	H1	H2	L1	L2	Weight [g]	Part no.	Type
15	11.5	M4x6	70	55	65	50	50	3018429	EAHM-E17-U-15
30	11.5	M5x8	80	65	75	60	95	3018428	EAHM-E17-U-30
100	11.5	M5x8	80	65	85	60	110	3018426	EAHM-E17-U-100

Accessories

Ordering data		For size	Part no.	Type
Plug socket with cable NEBU for multi-pin set EADH				
		15, 30, 100	8048086	NEBU-M12W8-K-15-N-LE8

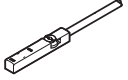
Ordering data					
	Switching output	Switching element function	Cable length [m]	Part no.	Type
Proximity switch for sensing kit EAPR-E17					
	PNP	N/C	2.5	174552	SIES-Q8B-PO-K-L
	PNP	N/O	2.5	178294	SIES-Q8B-PS-K-L
	NPN	N/C	2.5	174550	SIES-Q8B-NO-K-L
	NPN	N/O	2.5	178292	SIES-Q8B-NS-K-L

Accessories

Permissible combinations

Download CAD data → www.festo.com

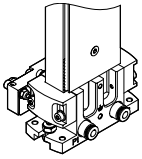

Combination with	Linear gantry Size	Drive/gripper Size	Adapter kit CRC ¹⁾	Part no.	Type
Semi-rotary drive					
DRRD	EXCT	DRRD	DHAA		
	15	10	2	2728486	DHAA-D-E8-45-Q11-10
	15, 30	12		2715152	DHAA-D-E8-45/55-Q11-12
	30	16		1926914	DHAA-D-E8-55-Q11-16
	100	16		1928306	DHAA-D-E8-75-Q11-16
	100	20		1930038	DHAA-D-E8-75-Q11-20
Parallel gripper					
DHPS	EXCT	DHPS	HMSV		
	15, 30	16	2	548785	HMSV-55
	100	20, 25		548786	HMSV-56
HGPD, sealed	EXCT	HGPD	DHAA, HAPG		
	15, 30	25	2	564952	DHAA-G-G6-16-B8-25
	100	25, 35		537175	HAPG-79
	100	40		564951	DHAA-G-G6-20-B8-40
HGPL, heavy-duty with long stroke	EXCT	HGPL	DHAA/HAPG		
	15, 30	14-20	2	2406159	DHAA-G-G6-16-B6-14
	100	14-20		2410181	DHAA-G-G6-20-B6-14
	15, 30	14-40, 14-60, 14-80		538055	HAPG-89
	100	14-40, 14-60, 14-80		539274	HAPG-90
	100	25		539274	HAPG-90
HGPP, precision	EXCT	HGPP	HAPG, HMSV		
	15, 30	10	2	529018	HAPG-58
	15, 30	12		191266	HAPG-48
	100	12		191267	HAPG-49
	100	16		191269	HAPG-51
HGPT-B, heavy-duty	EXCT	HGPT-B	DHAA, HAPG		
	15, 30	25	2	564952	DHAA-G-G6-16-B8-25
	100	40		564951	DHAA-G-G6-20-B8-40
	100	25, 35		537175	HAPG-79

1) Corrosion resistance class CRC 2 to Festo standard FN 940070

Moderate corrosion stress. Indoor applications in which condensation can occur. External visible parts with primarily decorative surface requirements that are in direct contact with a normal industrial environment.

Accessories

Permissible combinations

Download CAD data → www.festo.com

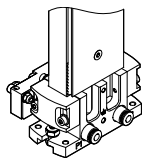

Combination with	Linear gantry Size	Drive/gripper Size	Adapter kit CRC ¹⁾	Part no.	Type
Radial grippers					
DHRS	EXCT	DHRS	HMSV		
	15, 30	16	2	548785	HMSV-55
	100	25, 32		548786	HMSV-56
HGRT, heavy-duty	EXCT	HGRT	DHAA		
	15, 30	20	2	1278364	DHAA-G-G6-12-B11-20
	15, 30	25		1279418	DHAA-G-E8-45-B11-25
	100	25		1468307	DHAA-G-G6-20-B11-25
	100	32		1280494	DHAA-G-G6-25-B11-32
Angle grippers					
DHWS	EXCT	DHWS	HMSV		
	15, 30	16	2	548785	HMSV-55
	100	25, 32		548786	HMSV-56
Three-point gripper					
HGDD, sealed	EXCT	HGDD	DHAA		
	15, 30, 100	35	2	2371422	DHAA-G-G3-20-B13-35
	100	40		2373773	DHAA-G-H2-16-B13-40
	100	50		2377625	DHAA-G-H2-20-B13-50
	EXCT	HGDD-G1/G2	DHAA/HAPG		
	15, 30, 100	35	2	542436	HAPG-94
100	40	542437		HAPG-95	
100	50	2378415		DHAA-G-H2-20-B13G-50	
HGDT, heavy-duty	EXCT	HGDT	HAPG		
	15, 30	25	2	542439	HAPG-SD2-32
	15, 30, 100	35		542436	HAPG-94
	100	40		542437	HAPG-95
	100	50		542443	HAPG-SD2-36

1) Corrosion resistance class CRC 2 to Festo standard FN 940070

Moderate corrosion stress. Indoor applications in which condensation can occur. External visible parts with primarily decorative surface requirements that are in direct contact with a normal industrial environment.

Festo - Your Partner in Automation



1 Festo Inc.
5300 Explorer Drive
Mississauga, ON L4W 5G4
Canada

Festo Customer Interaction Center
Tel: 1 877 463 3786
Fax: 1 877 393 3786
Email: customer.service.ca@festo.com



2 Festo Pneumatic
Av. Ceylán 3,
Col. Tequesquináhuac
54020 Tlalnepantla,
Estado de México

Multinational Contact Center
01 800 337 8669
ventas.mexico@festo.com



3 Festo Corporation
1377 Motor Parkway
Suite 310
Islandia, NY 11749

Festo Customer Interaction Center
1 800 993 3786
1 800 963 3786
customer.service.us@festo.com



4 Regional Service Center
7777 Columbia Road
Mason, OH 45040

Connect with us



www.festo.com/socialmedia



www.festo.com

Subject to change