

Guide axes EGC-FA, without drive

FESTO



Key features

At a glance

- Driveless linear guide units with guide and freely movable slide
- The guide axis is designed to support forces and torques in multi-axis applications
- Increased torsional resistance
- Reduced vibrations with dynamic loads
- Drive axis and guide axis can be placed adjacent to or above one another

System product for handling and assembly technology

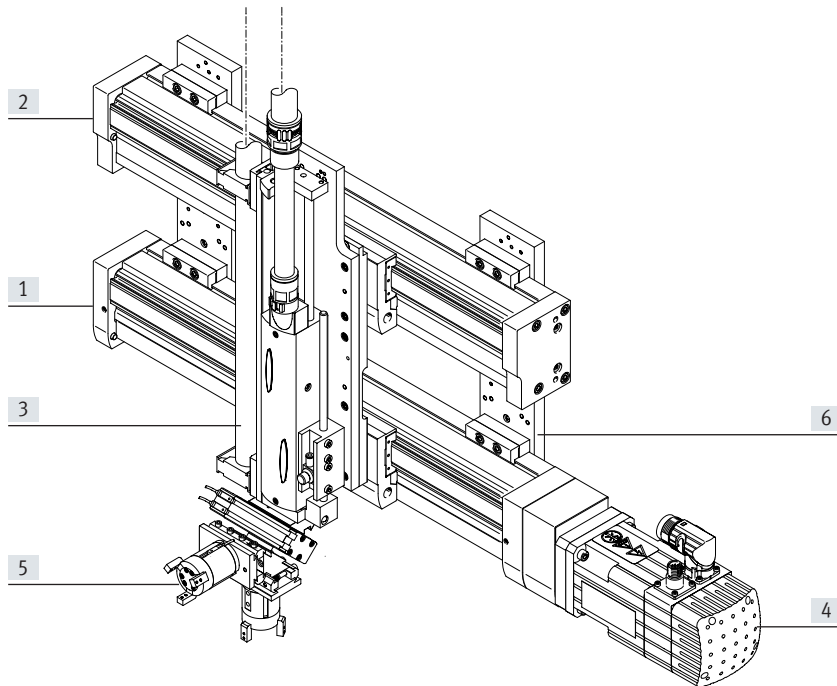

System components and accessories

	Description	→ Page/Internet
[1] Axes	Wide range of combinations possible within handling and assembly technology	axis
[2] Guide axes	For supporting forces and torques in multi-axis applications	guide axis
[3] Drives	Wide range of combinations possible within handling and assembly technology	drive
[4] Motors	Servo and stepper motors, with or without gearbox	motor
[5] Grippers	Wide range of variations possible within handling and assembly technology	gripper
[6] Adapter	For drive/drive and drive/gripper connections	adapter kit

Key features

Slide variants

Standard slide

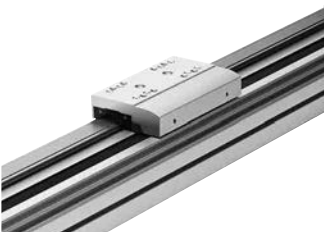

Extended slide



Additional slide



Guide options

Protected version



- The protected guide cleans the guide rail and protects the recirculating ball bearing guide with the aid of an additional wiper

With central lubrication



- The lubrication adapters enable the guide to be permanently lubricated using semi or fully automatic relubrication devices
- The adapters are suitable for oils and greases
- All lubrication connections must be connected

Clamping unit

→ Page 8

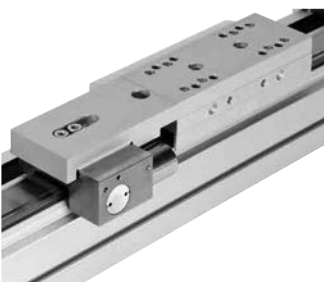

- 1- or 2-channel design, for holding loads
- Reliable holding is guaranteed since the forces act directly on the slide
- A limited number of emergency braking operations are permissible with sizes 120 and 185

Guide axes and the corresponding axes/drives

Guide axis ELFA-RF



- Can be combined with:
 - Toothed belt axis ELGA-TB-RF
- For size 70, 80
- Load capacity up to max. 800 N or 180 Nm

Guide axis DGC-FA



- Can be combined with:
 - Linear drive DGC-KF
- For size 8 ... 63
- Load capacity up to max. 15200 N or 1157 Nm

Guide axis EGC-FA



- Can be combined with:
 - Toothed belt axis EGC-TB
 - Spindle axis EGC-BS
- For size 70 ... 185
- Load capacity up to max. 15200 N or 1157 Nm

Peripherals overview

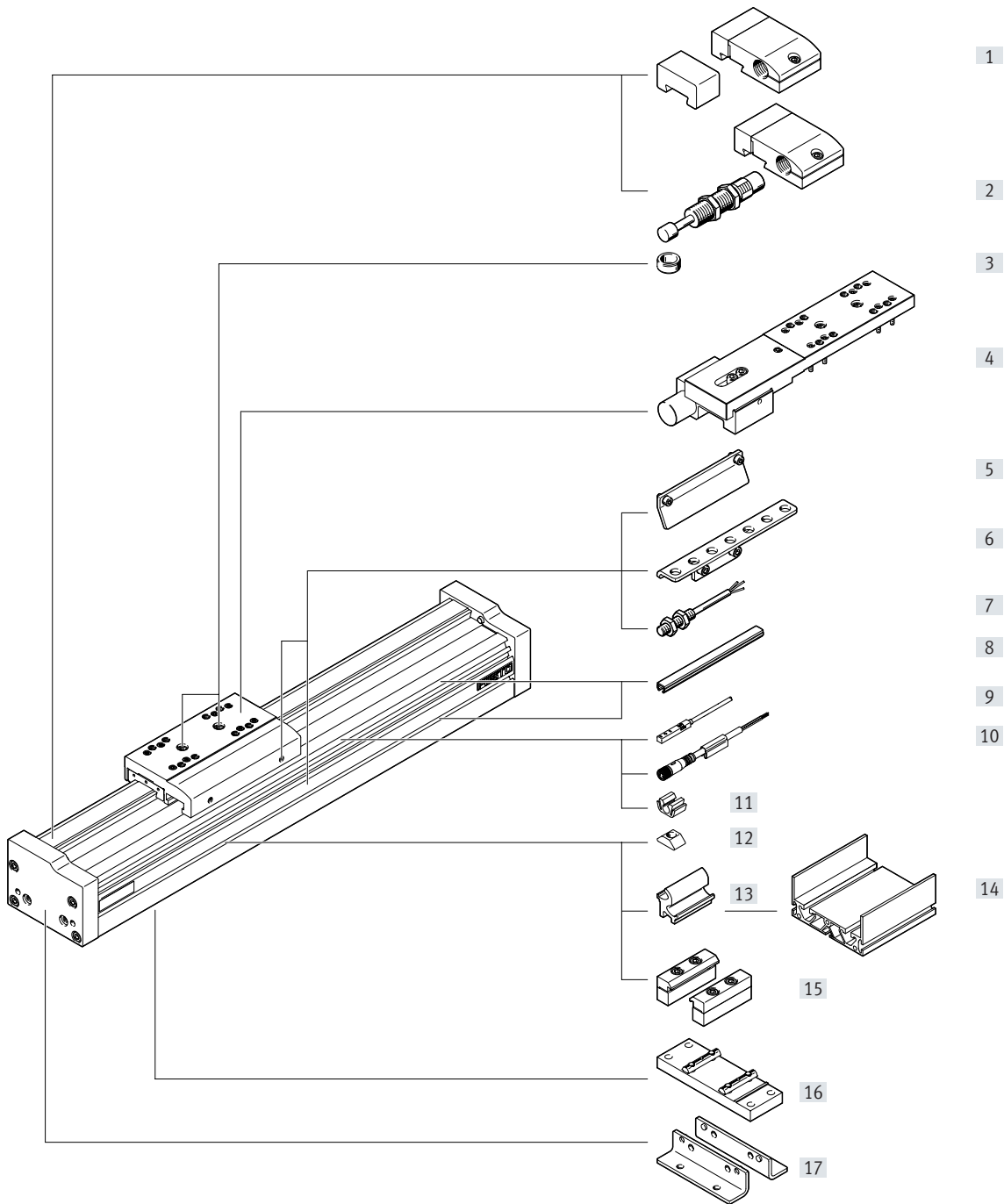

Peripherals overview

Variants and accessories		
Type/order code	Description	→ Page/Internet
[1] Emergency buffer with retaining bracket A	For avoiding damage at the end stop in the event of a malfunction	42
[2] Shock absorber with retaining bracket C	For avoiding damage at the end stop in the event of a malfunction	42
[3] Centring pin/sleeve ZBS, ZBH	<ul style="list-style-type: none"> • For centring loads and attachments on the slide • Included in the scope of delivery: <ul style="list-style-type: none"> – With size 70: 2x ZBS-5 – With size 80, 120, 185: 2x ZBH-9 	42
[4] Clamping unit 1H...-PN, 2H-PN	For holding loads	8
[5] Switch lug X, Z, O, P, W, R	For sensing the slide position	40
[6] Sensor bracket O, P, W, R	Adapter for mounting the inductive proximity switches (round design) on the axis	41
[7] Proximity switch, M8 O, P, W, R	<ul style="list-style-type: none"> • Inductive proximity switch, round design • The order code O, P, W, R includes 1 switch lug and max. 2 sensor brackets in the scope of delivery 	44
[8] Slot cover B, S	<ul style="list-style-type: none"> • For protection against contamination 	42
[9] Proximity switch, slot type 8 X, Z	<ul style="list-style-type: none"> • Inductive proximity switch, for slot type 8 • The order code X, Z includes 1 switch lug in the scope of delivery 	43
[10] Plug socket with cable V	For proximity switch (order code W and R)	44
[11] Clip CL	For mounting the proximity switch cable in the slot	42
[12] Slot nut Y	For mounting attachments	42
[13] Adapter kit DHAM	For mounting the support profile on the axis	43
[14] Support profile HMIA	For mounting and guiding an energy chain	43
[15] Profile mounting M	For mounting the axis on the side of the profile	38
[16] Central support EAHF	For mounting the axis on the bottom of the profile	39
[17] Foot mounting F	For mounting the axis on the end cap	37



Type codes

001	Series	
EGC	Electric linear axis	
002	Size	
70	70	
80	80	
120	120	
185	185	
003	Stroke	
...	50 ... 8500	
004	Guide	
FA	Guide axis	
005	Stroke reserve	
OH	None	
...H	0 ... 999 mm	
006	Slide	
GK	Standard slide	
GP	Standard slide, protected	
GV	Extended slide	
GQ	Extended slide, protected	
007	Additional slide left	
KL	Additional slide, standard, left	
008	Additional slide, right	
KR	Additional slide standard, right	
009	Lubrication function	
	None	
C	Lubrication adapter	
010	Clamping unit	
	None	
1HL	Holding function, 1-channel, left	
1HR	Single-channel holding function, right	
2H	Holding function, 2-channel	
011	Actuation type	
	None	
PN	Pneumatically actuated	
012	Accessories	
	None	
ZUB-	Accessories supplied loose	
013	Foot mounting	
	None	
F	1 record	
014	Profile mounting	
	None	
...M	1 - 50 pieces	
015	Mounting slot covering	
	None	
...B	1 ... 50 pieces	

016	Slot cover, sensor slot	
	Without	
...S	1 - 50 pieces	
017	Slot nut, mounting slot	
	Without	
...Y	1 ... 99 pieces	
018	Proximity switch, inductive, slot 8, PNP, N/O contact, cable 7.5 m	
	None	
...X	1 ... 6 pieces	
019	Proximity switch, inductive, slot 8, N/C contact, cable 7.5 m	
	None	
...Z	1 ... 6 pieces	
020	Emergency buffer with retaining bracket	
	Without	
...A	1 ... 2 pieces	
021	Shock absorber with retaining bracket	
	None	
...C	1 ... 2 pieces	
022	Proximity switch, inductive, M8, PNP, N/O contact, cable 2.5 m	
	Without	
...O	1 ... 99 pieces	
023	Proximity switch, inductive, M8, PNP, N/C contact, cable 2.5 m	
	None	
...P	1 ... 99 pieces	
024	Proximity switch, inductive, M8, PNP, N/C contact, M8 plug	
	None	
...R	1 ... 99 pieces	
025	Proximity switch, inductive, M8, PNP, N/O contact, M8 plug	
	Without	
...W	1 ... 99 pieces	
026	Connecting cable 2.5 m, M8, 3-wire	
	None	
...V	1 ... 99 pieces	
027	Cable clip	
	None	
10CL	10 pieces	
20CL	20 pieces	
30CL	30 pieces	
40CL	40 pieces	
50CL	50 pieces	
60CL	60 pieces	
70CL	70 pieces	
80CL	80 pieces	
90CL	90 pieces	
100CL	100 units	
028	Operating instructions	
	With operating instructions	
DN	Without operating instructions	

Data sheet



-  Size
70 ... 185
-  Stroke length
50 ... 8500 mm
-  www.festo.com

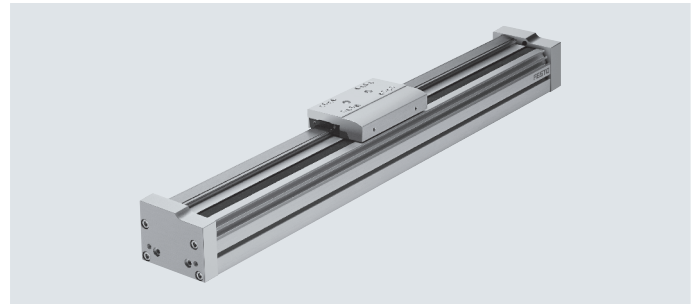

General technical data					
Size		70	80	120	185
Design	Guide				
Guide	Recirculating ball bearing guide				
Mounting position	Any				
Working stroke					
EGC...-GK/-GP	[mm]	50 ... 5000	50 ... 8500	50 ... 8500	50 ... 8500
Max. speed	[m/s]	5			
Max. acceleration	[m/s ²]	50			
Operating and environmental conditions					
Ambient temperature	[°C]	-10 ... +60			
Degree of protection	IP40				
Weight [kg]					
Size		70	80	120	185
Basic weight with 0 mm stroke ¹⁾					
EGC...-GK/-GP		1.20	2.00	7.30	20.80
Additional weight per 1000 mm stroke		4.20	6.20	15.00	29.00
Moving mass					
EGC...-GK/-GP		0.30	0.55	2.00	6.00
Additional slide					
EGC...-KL/-KR		0.30	0.55	2.00	6.00
Clamping unit					
EGC...-1H...-PN		-	0.70	2.30	4.90
EGC...-2H-PN		-	1.30	4.00	8.30

1) Incl. slide

Data sheet

Materials

Sectional view

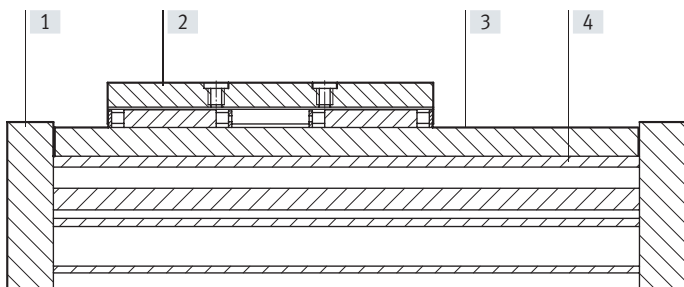

Axis	
[1] End cap	Anodised wrought aluminium alloy
[2] Slide	Anodised wrought aluminium alloy
[3] Guide rail	High-alloy steel
[4] Profile	Anodised wrought aluminium alloy
Note on materials	RoHS-compliant
	Contains paint-wetting impairment substances

Technical data – Clamping unit

Dimensions → page 29

Size	80	120	185
Pneumatic connection	M5	M5	M5
Clamping type	Clamping via spring force, compressed air to release		
Static holding force			
EGC...-1H...-PN [N]	320	1200	1500
EGC...-2H-PN [N]	640	2400	3000
Max. number of emergency braking operations ¹⁾ at reference energy [J]	–	750 35	750 70
Number of clamping operations under rated load [millions of switching cycles]	0.45	0.05	> 1.4

1) Emergency braking refers to braking the payload if the drive axis loses power.

Operating and environmental conditions – Clamping unit

Operating medium	Compressed air to ISO 8573-1:2010 [7:4:4]		
Operating pressure			
Clamping unit open [bar]	4.5 ... 8		
Clamping unit closed [bar]	Unpressurised		
Ambient temperature [°C]	–10 ... +60		

Data sheet

Characteristic load values

The indicated forces and torques refer to the slide surface. The point of application of force is the point where the centre of the guide and the longitudinal centre of the slide intersect.

These values must not be exceeded during dynamic operation. Special attention must be paid to the deceleration phase.

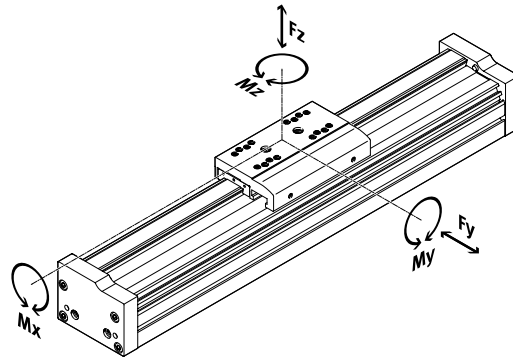

If the axis is subjected to two or more of the indicated forces and torques simultaneously, the following equation must be satisfied in addition to the indicated maximum loads:

Calculating the load comparison factor:

$$f_v = \frac{|F_{y1}|}{F_{y2}} + \frac{|F_{z1}|}{F_{z2}} + \frac{|M_{x1}|}{M_{x2}} + \frac{|M_{y1}|}{M_{y2}} + \frac{|M_{z1}|}{M_{z2}} \leq 1$$

Permissible forces and torques			70	80	120	185
Size						
$F_{y_{max}}$	[N]		1850	3050	6890	15200
$F_{z_{max}}$	[N]		1850	3050	6890	15200
$M_{x_{max}}$	[Nm]		16	36	144	529
$M_{y_{max}}$	GK/GP [Nm]		51	97	380	1157
$M_{z_{max}}$	GK/GP [Nm]		51	97	380	1157

Service life

The service life of the guide depends on the load. To provide a rough indication of the service life of the guide, the graph below plots the load comparison factor f_v against the service life.

These values are only theoretical. You must consult your local contact person at Festo for load comparison factors f_v greater than 1.5.

Load comparison factor f_v as a function of service life

Example:

A user wants to move an X kg load. Using the above formula gives a value of 1.5 for the load comparison factor. According to the graph, the guide would have a service life of approx. 1500 km. Reducing the acceleration reduces the M_z and M_y values. A load comparison factor of 1 now gives a service life of 5000 km.

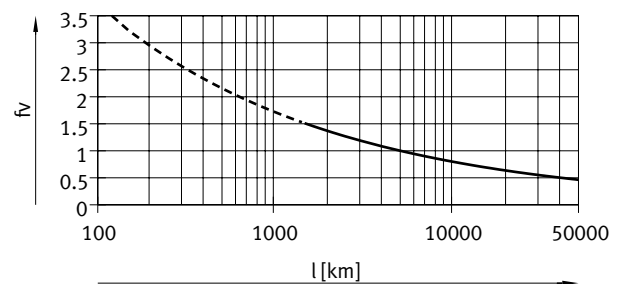

Note

Engineering software
Electric Motion Sizing
www.festo.com

The engineering software can be used to calculate the guide workload for a service life of 5000 km.

$f_v > 1.5$ are only theoretical comparison values for the recirculating ball bearing guide.

Data sheet

Stroke reserve

Stroke length

Stroke reserve

The selected stroke corresponds in principle to the required working stroke. The variant GK does not have a wiper ring on the guide. This variant therefore additionally has a safety distance between the drive cover and slide that is not designated as part of the working stroke.

It is possible to define a safety distance (similar to that for GK) between the drive cover and slide for the variants GP and GK-C using the “stroke reserve” characteristic in the modular product system. For the variant GK, the stroke reserve and safety distance are added for each end position.

- The stroke reserve length can be freely selected
- The sum of the stroke length and 2x stroke reserve must not exceed the maximum working stroke

Example:

EGC-70-500-FA-20H-...

Working stroke = 500 mm

2x stroke reserve = 40 mm

Total length = 540 mm

(540 mm = 500 mm + 2x 20 mm)

Size	70	80	120	185
L9 = safety distance for GK (per end position) [mm]	10.5	13	18	21

Working stroke reduction

With standard slide GK/GP / extended slide GV/GQ with additional slide KL/KR

- In the case of a guide axis with additional slide, the working stroke is reduced by the length of the additional slide and the distance between the two slides
- If the variant GP/GQ is ordered, the additional slide is also protected
- If the variant GV/GQ is ordered, the additional slide is not extended
- If the variant GK-C is ordered, the additional slide is also supplied with lubrication adapters

L17 = slide length

L = distance between the two slides

[1] = additional slide

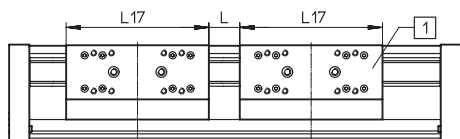

Example:

Type EGC-70-500-FA-...-GK-KL/KR

Working stroke without additional slide = 500 mm

L = 20 mm

L17 = 100 mm

Working stroke with

additional slide = 380 mm

(500 mm – 20 mm – 100 mm)

Dimensions – Additional slide

Size	70		80		120		185	
Variant	GK/GV	GP/GQ or GK-C/ GV-C	GK/GV	GP/GQ or GK-C/ GV-C	GK/GV	GP/GQ or GK-C/ GV-C	GK/GV	GK-C/GV-C
Length L17 [mm]	100	125	120	146	200	236	280	322

Data sheet

Working stroke reduction per side

With integrated emergency buffer NPE/shock absorber YSRW with shock absorber retainer KYE

- The working stroke is reduced by the total dimension of the emergency buffer/ shock absorber and shock absorber retainer.
- The rubber buffer in the cap must be removed.
- Shock absorbers must not be used in combination with GK-C.

Size		70	80	120	185
With emergency buffer	[mm]	43	68	98	133
With shock absorber	[mm]	42	63	84	107

Working stroke reduction

With integrated clamping unit

- The working stroke is reduced by the length of the clamping unit.
- With 1-channel clamping units, the stroke is reduced on one side with respect to the mounting surface
- With 2-channel clamping units, the stroke is reduced symmetrically with respect to the mounting surface of the load
- Shock absorbers must not be used in combination with the clamping unit.

Size		80	120	185
EGC-...-1H...-PN	[mm]	87	124	131
EGC-...-2H-PN	[mm]	174	248	262

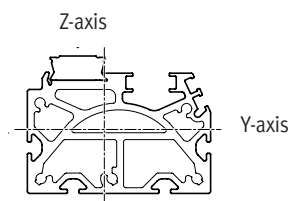
2nd moments of area

Size		70	80	120	185
I _y	[mm ⁴]	3.95x10 ⁵	8.44x10 ⁵	4.62x10 ⁶	2.34x10 ⁷
I _z	[mm ⁴]	5.77x10 ⁵	1.16x10 ⁶	5.65x10 ⁶	2.74x10 ⁷

Data sheet

Maximum permissible support spacing L (without profile mounting MUE/central support EAHF) as a function of force F

In order to limit deflection in the case of large strokes, the axis may need to be supported.

The following graphs can be used to determine the maximum permissible support span l as a function of force F acting on the axis. The deflection is $f = 0.5 \text{ mm}$.

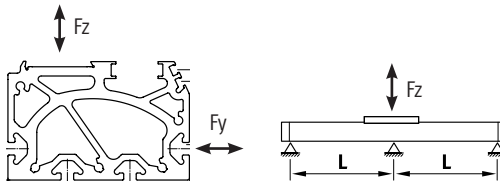

Force Fy

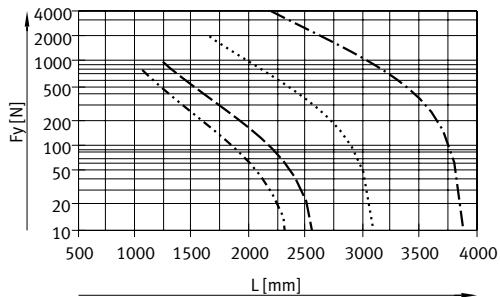

- EGC-70
- EGC-80
- - - EGC-120
- · - · - EGC-185

Force Fz

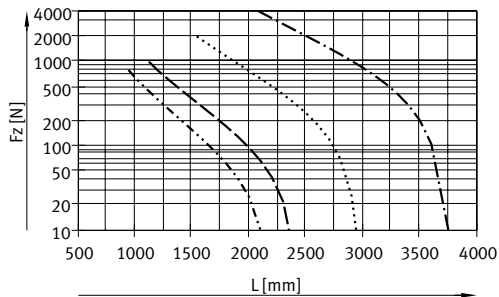

Recommended deflection limits

Adherence to the following deflection limits is recommended so as not to impair the functionality of the axes. Greater deformation can result in increased friction, greater wear and reduced service life.

Size	Dynamic deflection (moving load)	Static deflection (stationary load)
70 ... 185	0.05% of the axis length, max. 0.5 mm	0.1% of the axis length

Data sheet

Dimensions

Download CAD data → www.festo.com

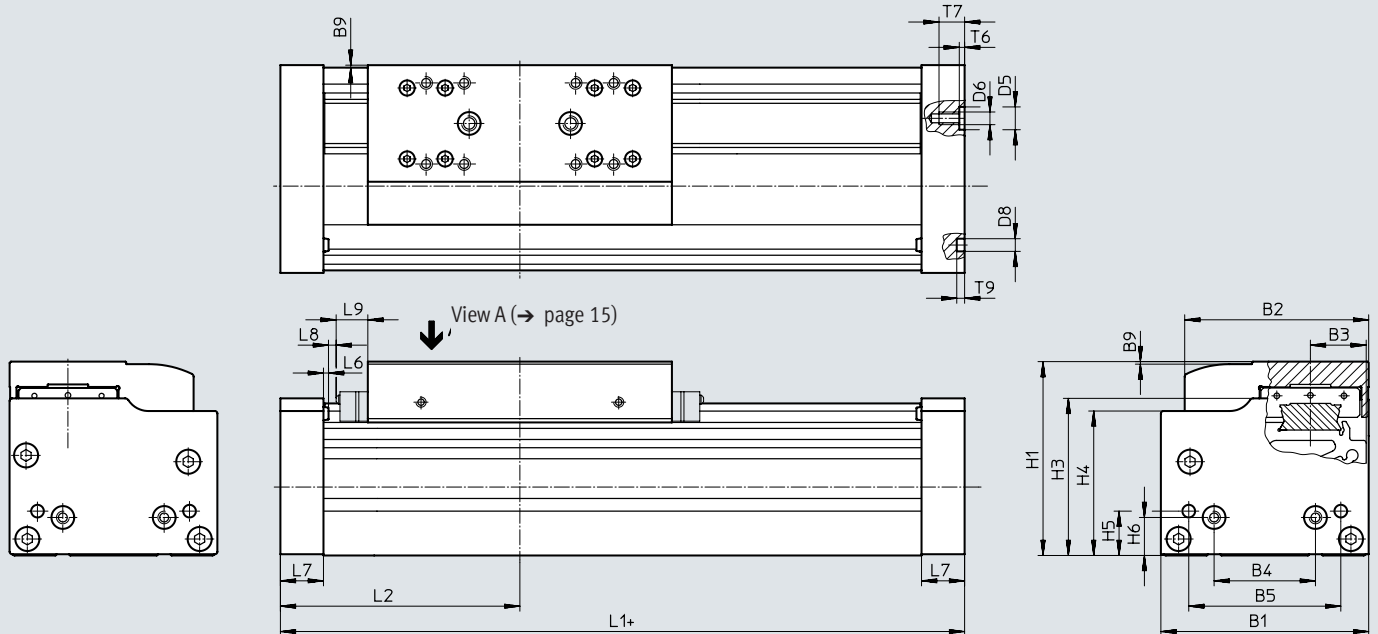

- + = plus stroke length + 2x stroke reserve
- L9 = for GK: safety distance per end position;
for GP: dimension for wiper seal → page 10;
for GK-C/GV-C: dimension for adapter → page 23

Size	B1	B2	B3	B4	B5	B9	D5 ∅ H7
70	69	58.6	16.5	30	45	1	–
80	82	72.6	22	40	60	1	9
120	120	107	33	80	40	1	–
185	186	169	53	120	80	1	–

Size	D6	D8 ∅ H7	H1	H3	H4	H5	H6	L1
70	M5	5	64	50.5	47	13	13	163
80	M5	5	76.5	62	57	17.5	15	190
120	M8	9	111.5	89	82	22	22	306
185	M10	9	172.5	141	131.5	25	25	406

Size	L2	L6	L7	L8	L9	T6	T7	T9
70	81.5	1.8	16	3	10.5	–	10	3.1
80	95	2	17	3	13	2.1	10.1	3.1
120	153	2	30	3	18	–	16	2.1
185	203	2	37	3	21	–	20	2.1

Data sheet

Profile

Size 70

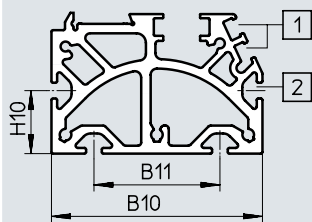

Size 80

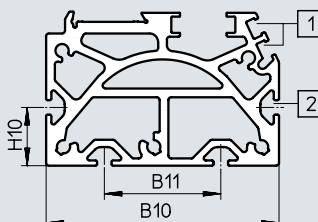

Size 120

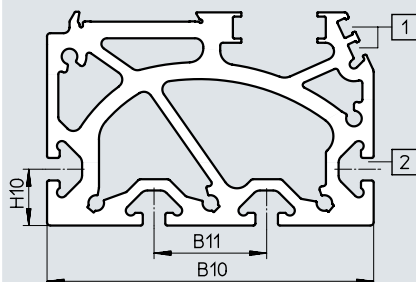

Size 185

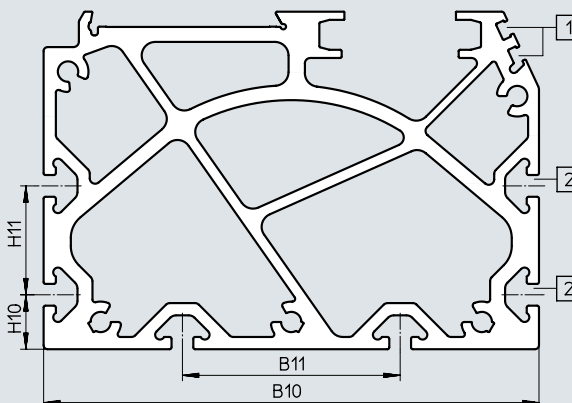

- [1] Sensor slot for proximity switch
- [2] Mounting slot for slot nut

Size	B10	B11	H10	H11
70	67	40	20	-
80	80	40	20	-
120	116	40	20	-
185	182	80	20	40

 **Note**

Requirements for the flatness of the bearing surface and of attachments as well as for use in parallel structures

→ www.festo.com/sp
User documentation

Data sheet

Dimensions

Download CAD data → www.festo.com

GK – Standard slide / GP – Standard slide, protected

Size 70

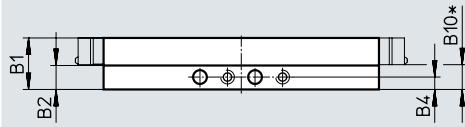

View A

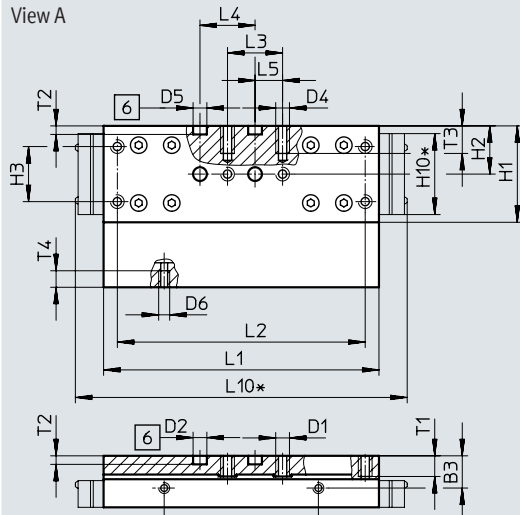

Size 80

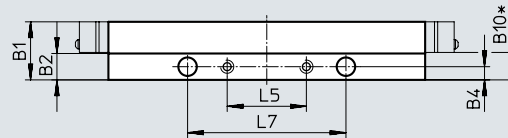

View A

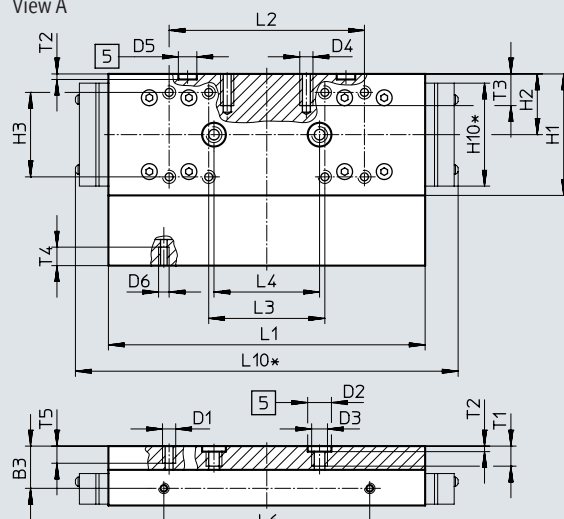

[5] Drill hole for centring sleeve

[6] Drilled hole for centring pin

* Protected version

Size	B1	B2	B3	B4	B10*	D1	D2 ∅ H7	D3	D4	D5 ∅ H7	D6	H1	H2	H3
70	18.7	8.7	11.7	4.5	9	M5	5	–	M5	5	M4	35	17.5	20 ±0.1
80	22	10	16	5	10.4	M5	9	M6	M5	7	M4	46	23	32 ±0.2

Size	H10*	L1	L2	L3	L4	L5	L6	L7	L10*	T1	T2	T3	T4	T5
		±0.1				±0.03		±0.1	±0.05		+0.1			
70	29.4	100	90 ±0.1	20 ±0.1	20	10 ±0.1	56	–	121	7.5	3.1	10	6	–
80	39	120	74 ±0.2	44 ±0.2	40	30 ±0.1	78	60	145	8.6	2.1	12	7	7.5

* Protected version

Data sheet

Dimensions

Download CAD data → www.festo.com

GK – Standard slide / GP – Standard slide, protected

Size 120

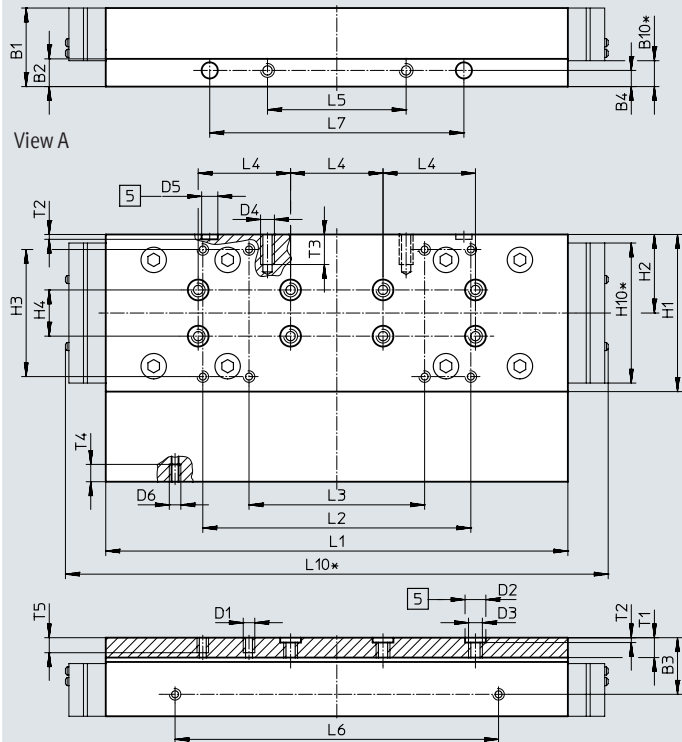

- [5] Drill hole for centring sleeve
- [6] Drilled hole for centring pin
- * Protected version

Size	B1	B2	B3	B4	B10*	D1	D2 ∅ H7	D3	D4	D5 ∅ H7	D6	H1	H2	H3	H4
120	34	12	24.5	7	11.2	M5	9	M6	M6	7	M5	68	34	55 ±0.2	20 ±0.03

Size	H10*	L1	L2	L3	L4	L5	L6	L7	L10*	T1	T2	T3	T4	T5
120	60.6	203.3 ±0.1	116 ±0.2	76 ±0.2	40 ±0.03	60 ±0.1	140 ±0.1	110 ±0.05	235	8.6	2.1 ±0.1	13	7.5	7.5

* Protected version

Data sheet

Dimensions

Download CAD data → www.festo.com

GK – Standard slide

Size 185

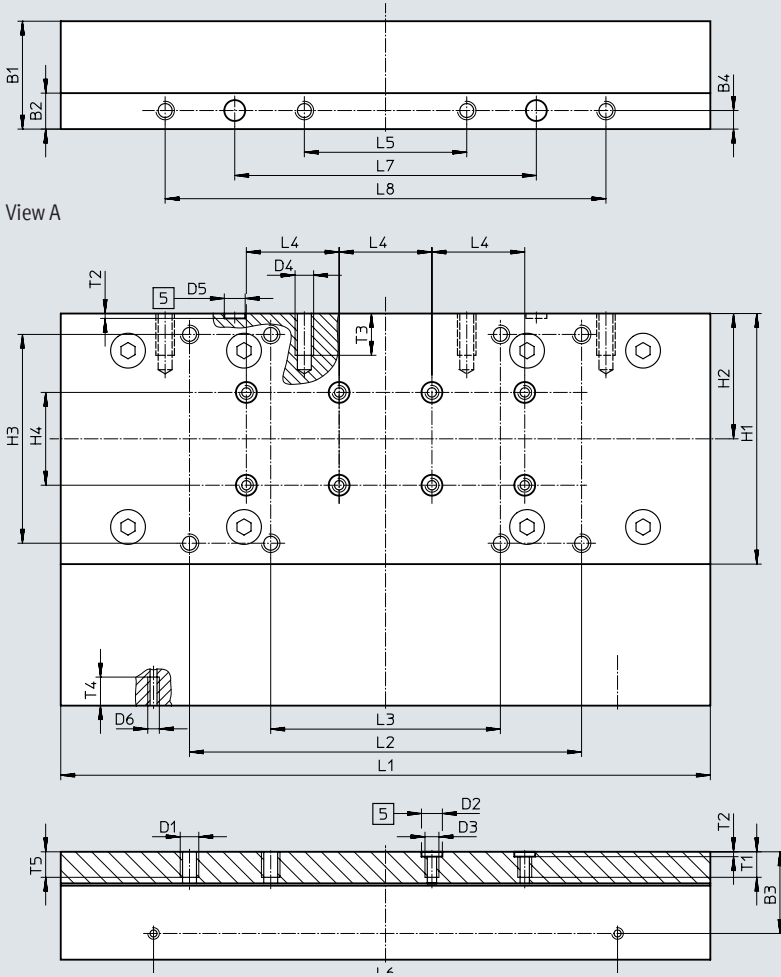

[5] Drill hole for centring sleeve

Size	B1	B2	B3	B4	D1	D2 ∅ H7	D3	D4	D5 ∅ H7	D6	H1	H2	H3	H4 ±0.03
185	46.5	15.5	35.2	8	M8	9	M6	M8	9	M5	108	54	90 ±0.2	40

Size	L1	L2	L3	L4	L5	L6	L7	L8	T1	T2	T3	T4	T5
	±0.1			±0.03		±0.1	±0.05	±0.2		+0.1			
185	282.8	169 ±0.2	99 ±0.2	40	70 ±0.2	200	130	190	11	2.1	18	12.3	12

Data sheet

Dimensions

Download CAD data → www.festo.com

GV – Extended slide / GQ – Extended slide, protected

Size 70

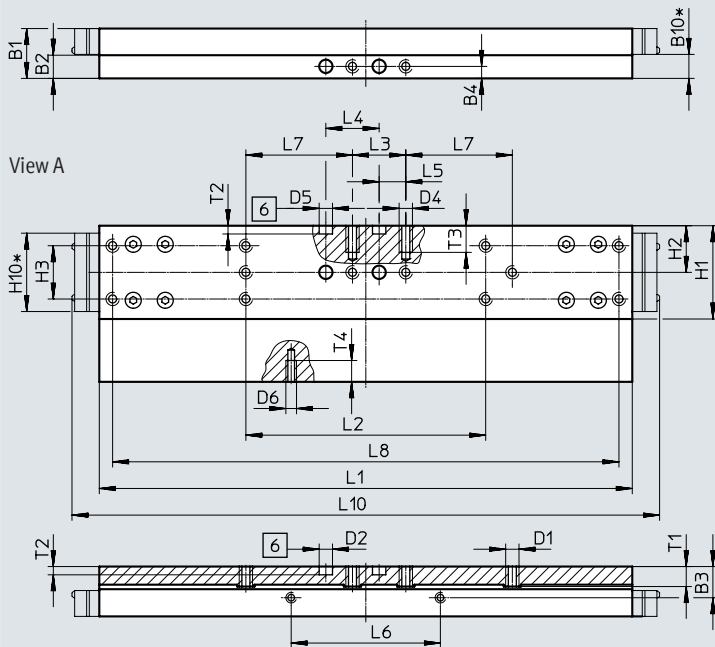

[6] Drill hole for centring sleeve
* Protected version

Size	B1	B2	B3	B4	B10*	D1	D2 ∅ H7	D4	D5 ∅ H7
70	18.7	8.7	11.7	4.5	9	M5	5	M5	5
Size	D6	H1	H2	H3	H10*	L1	L2	L3	L4
70	M4	35	17.5	±0.1 20	±0.1 29.4	±0.1 200	±0.1 90	±0.1 20	±0.03 20
Size	L5	L6	L7	L8	L10*	T1	T2	T3	T4
70	±0.1 10	±0.1 56	±0.1 40	±0.2 190	±0.1 221		+0.1 3.1		10 6

* Protected version

Data sheet

Dimensions

Download CAD data → www.festo.com

GV – Extended slide / GQ – Extended slide, protected

Size 80

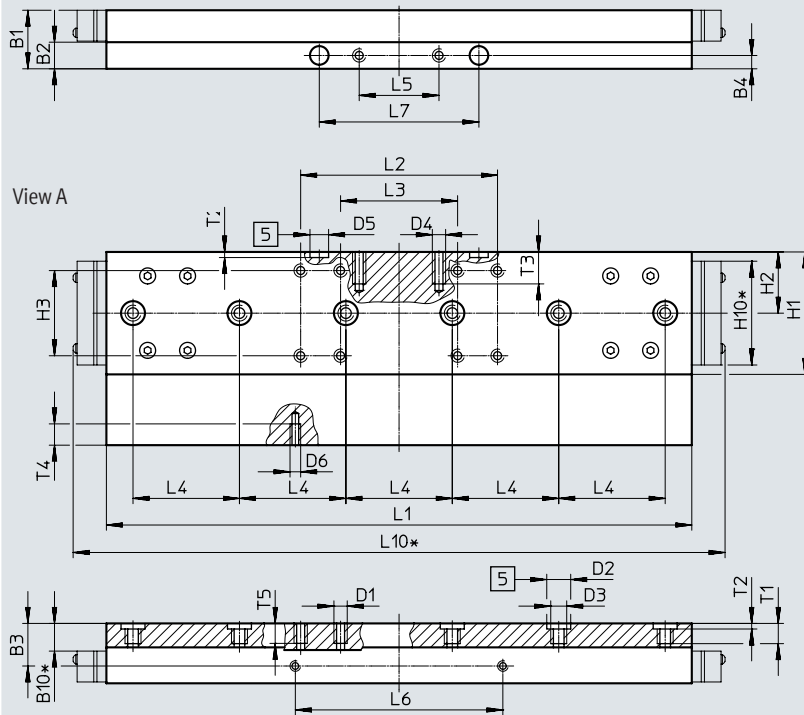

[5] Drill hole for centring sleeve
* Protected version

Size	B1	B2	B3	B4	B10*	D1	D2 ∅ H7	D3	D4	D5 ∅ H7
80	22	10	16	5	10.4	M5	9	M6	M5	7

Size	D6	H1	H2	H3	H10*	L1	L2	L3	L4
80	M4	46	23	±0.2 32	39	±0.1 220	±0.2 74	±0.2 44	±0.03 40

Size	L5	L6	L7	L10*	T1	T2	T3	T4	T5
80	±0.1 30	±0.1 78	±0.05 60	245	8.6	+0.1 2.1	12	7	7.5

* Protected version

Data sheet

Dimensions

Download CAD data → www.festo.com

GV – Extended slide / GQ – Extended slide, protected

Size 120

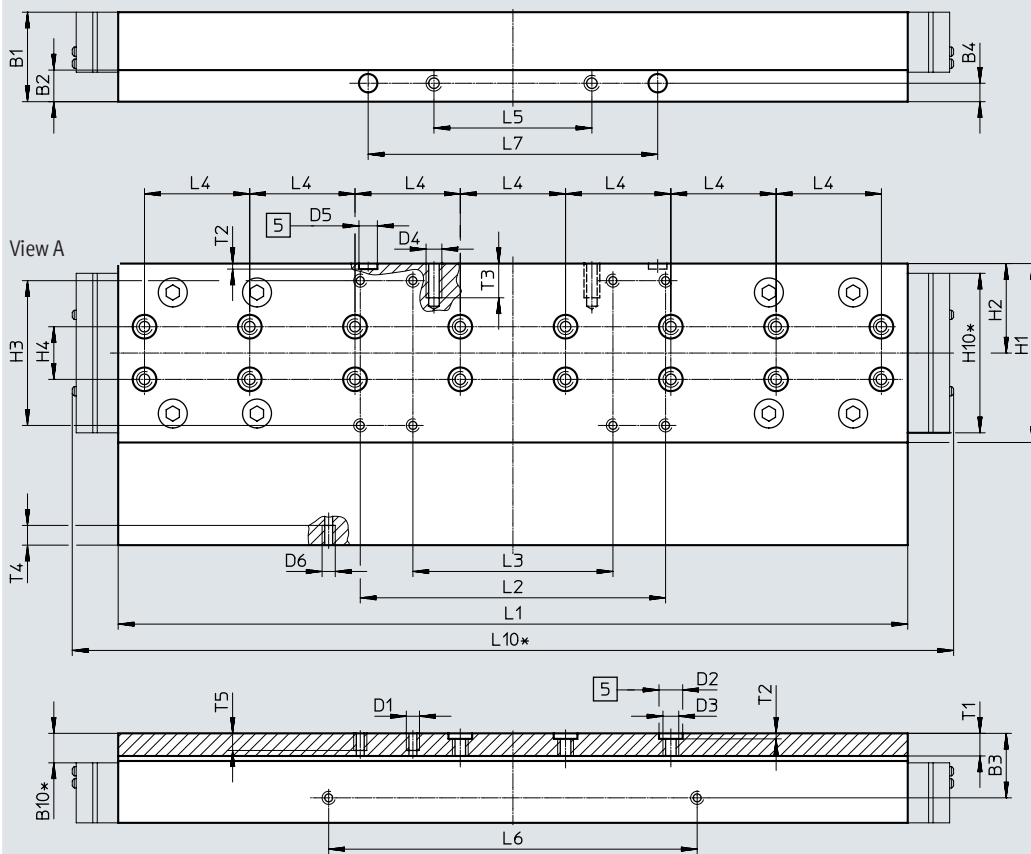

[5] Drill hole for centring sleeve

* Protected version

Size	B1	B2	B3	B4	B10*	D1	D2 ∅ H7	D3	D4	D5 ∅ H7
120	34	12	24.5	7	11.2	M5	9	M6	M6	7

Size	D6	H1	H2	H3	H4	H10*	L1	L2	L3	L4
120	M5	68	34	55 ±0.2	20	60.6	303.3	116 ±0.2	76 ±0.2	40

Size	L5	L6	L7	L8	L10*	T1	T2	T3	T4	T5
120	±0.1	±0.1	110±0.05	±0.2	335	8.6	±0.1	13	7.5	7.5

* Protected version

Data sheet

Dimensions

Download CAD data → www.festo.com

GV – Extended slide

Size 185

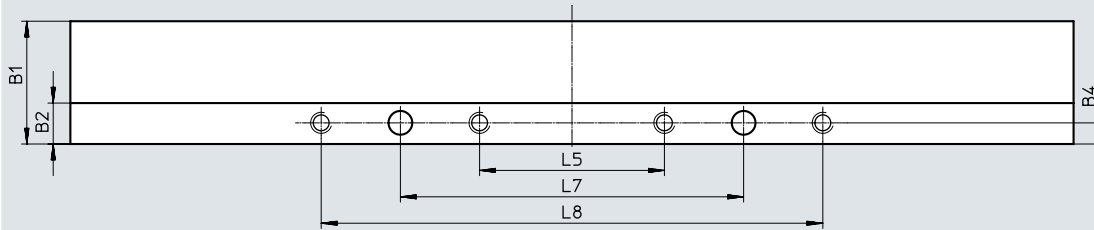

View A

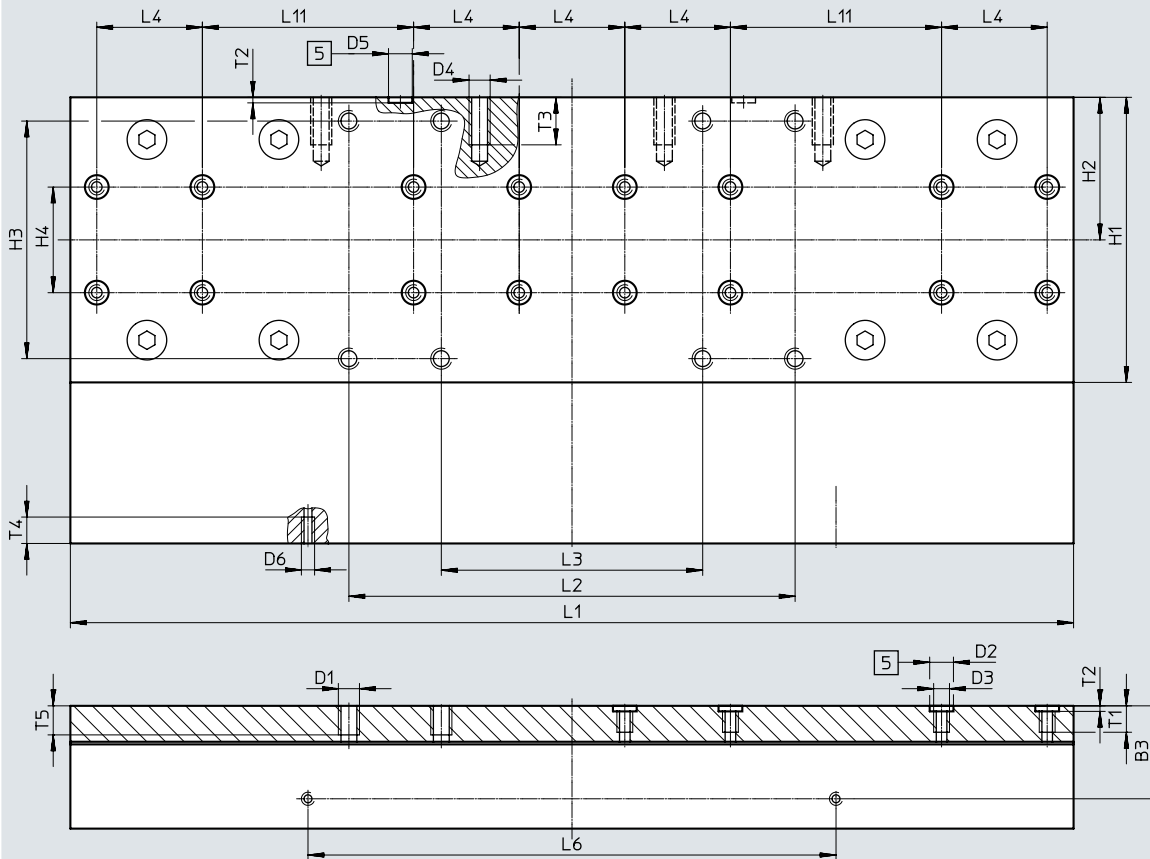

[5] Drill hole for centring sleeve

Size	B1	B2	B3	B4	D1	D2 ∅ H7	D3	D4	D5 ∅ H7
185	46.5	15.5	35.2	8	M8	9	M6	M8	9

Size	D6	H1	H2	H3	H4	L1	L2	L3	L4
185	M5	108	54	90	40	±0.1	±0.2	±0.2	±0.03

Size	L5	L6	L7	L8	L11	T1	T2	T3	T4	T5
185	±0.2	±0.1	±0.05	±0.2	±0.03	11	+0.1	18	10	12

Data sheet

Dimensions

Download CAD data → www.festo.com

GK-C – Standard slide with lubrication adapter

Size 70

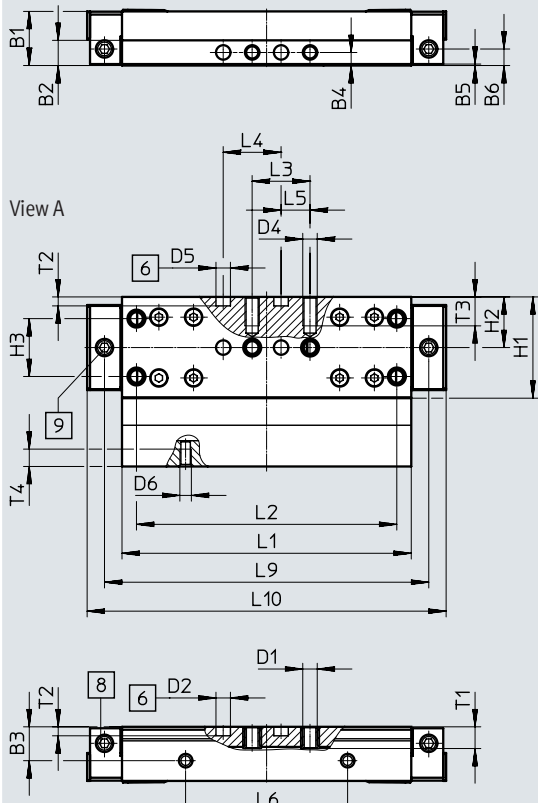

- [6] Drilled hole for centring pin
- [8] Lubricating hole for lubrication adapter
M6 threaded connection, 6 mm deep
- [9] Lubricating hole for lubrication adapter
M6 threaded connection, 5.5 mm deep

Size	B1	B2	B3	B4	B5	B6	D1	D2 ∅ H7	D4	
70	18.7	8.7	11.7	4.5	0.5	5.7	M5	5	M5	
Size	D5 ∅ H7	D6	H1	H2	H3	L1	L2	L3	L4	
70	5	M4	35	17.5	±0.1	±0.1	±0.1	±0.1	±0.03	
Size	L5	L6	L9	L10	L11	T1	T2	T3	T4	
70	10	±0.1	56	112.1	124.1	30	7.5	+0.1	10	6

Data sheet

Dimensions

Download CAD data → www.festo.com

GK-C – Standard slide with lubrication adapter

Size 80

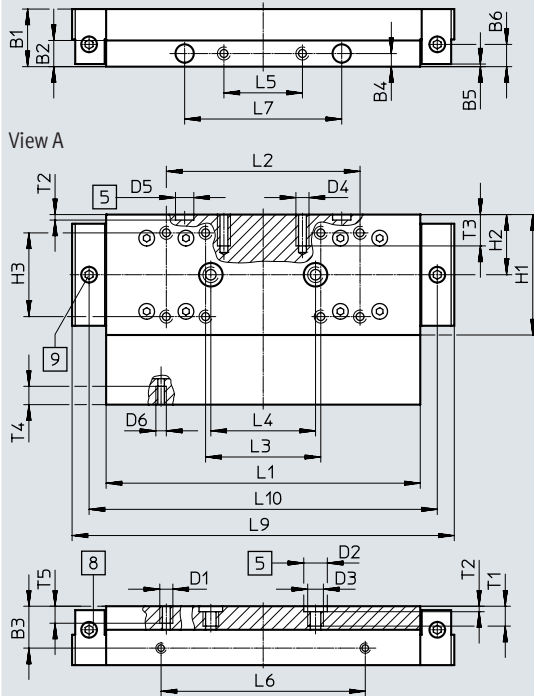

Size 120

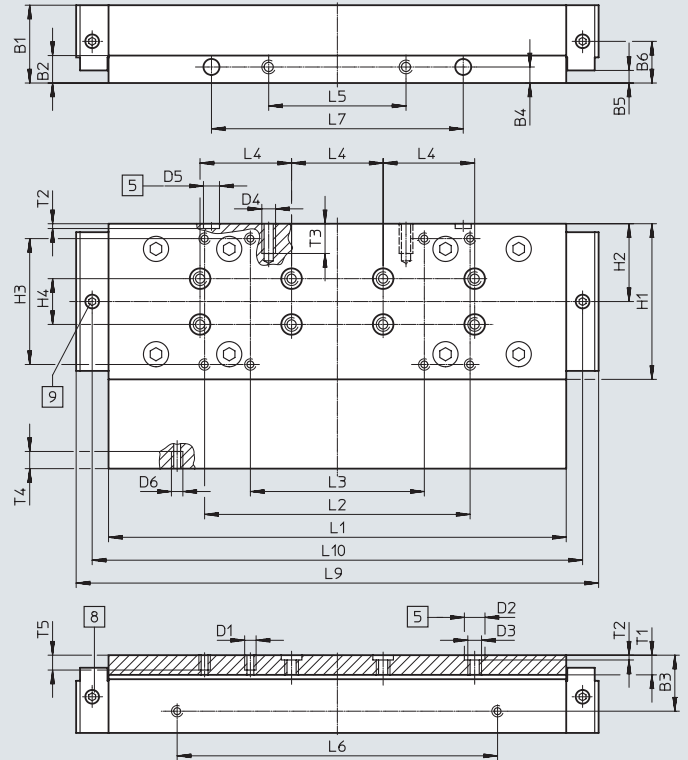

- [5] Drill hole for centring sleeve
- [6] Drilled hole for centring pin
- [8] Lubricating hole for lubrication adapter
M6 threaded connection, 6 mm deep
- [9] Lubricating hole for lubrication adapter
M6 threaded connection, 5.5 mm deep

Size	B1	B2	B3	B4	B5	B6	D1	D2 ∅ H7	D3	D4
80	22	10	16	5	1	8.5	M5	9	M6	M5
120	34	12	24.5	7	5.5	13.9	M5	9	M6	M6

Size	D5 ∅ H7	D6	H1	H2	H3	H4	L1	L2	L3	L4
80	7	M4	46	23	32	–	120	74	44	40
120	7	M5	68	34	55	20	203.3	116	76	40

Size	L5	L6	L7	L9	L10	T1	T2	T3	T4	T5
80	30	78	60	146	133	8.6	2.1	12	7	7.5
120	60	140	110	228.3	214.3	8.6	2.1	13	7.5	7.5

Data sheet

Dimensions

Download CAD data → www.festo.com

GK-C – Standard slide with lubrication adapter

Size 185

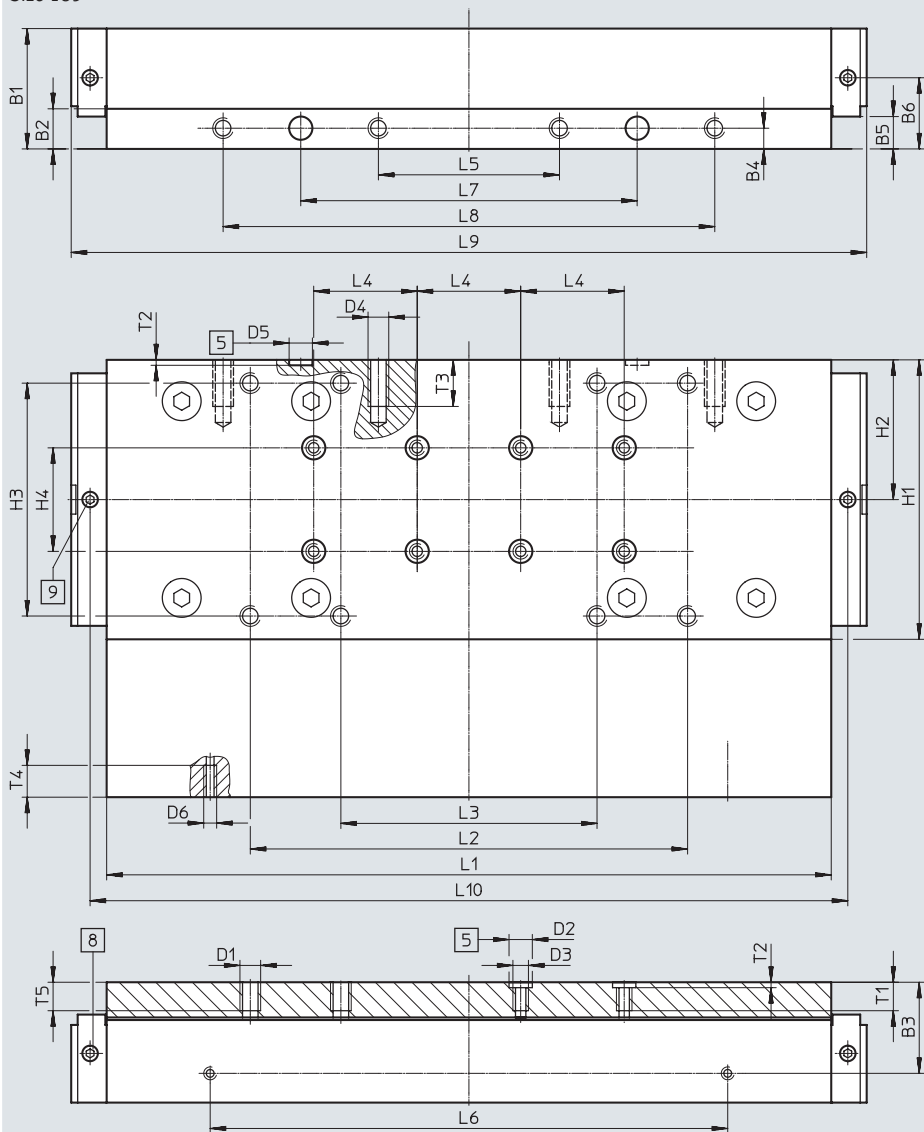

[5] Drill hole for centring sleeve

[8] Lubricating hole for lubrication adapter
M6 threaded connection, 6 mm deep

[9] Lubricating hole for lubrication adapter
M6 threaded connection, 5.5 mm deep

Size	B1	B2	B3	B4	B5	B6	D1	D2 ∅ H7	D3	D4
185	46.5	15.5	35.2	8	±0.1 12.5	27.5	M8	9	M6	M8

Size	D5 ∅ H7	D6	H1	H2	H3	H4	L1	L2	L3	L4
185	9	M5	108	54	±0.2 90	±0.03 40	±0.1 282.8	±0.2 169	±0.2 99	±0.03 40

Size	L5	L6	L7	L8	L9	L10	T1	T2	T3	T4	T5
185	±0.2 70	±0.1 200	±0.05 130	±0.2 190	307.4	292.8	11	+0.1 2.1	18	12.3	12

Data sheet

Dimensions

Download CAD data → www.festo.com

GV-C – Extended slide with lubrication adapter

Size 70

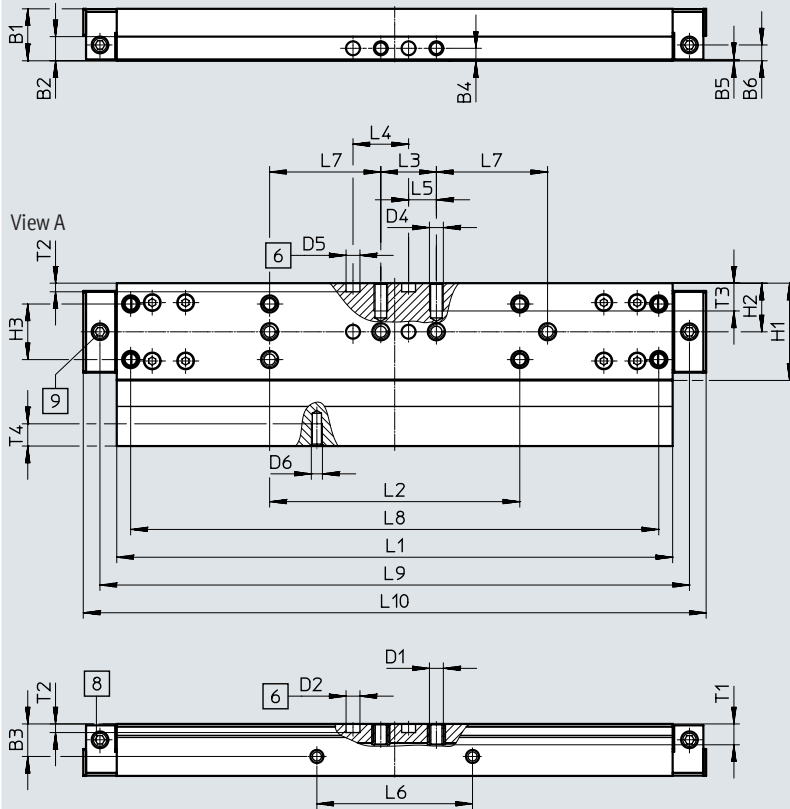

- [6] Drilled hole for centring pin
- [8] Lubricating hole for lubrication adapter
M6 threaded connection, 6 mm deep
- [9] Lubricating hole for lubrication adapter
M6 threaded connection, 5.5 mm deep

Size	B1	B2	B3	B4	B5	B6	D1	D2 ∅	D4	D5 ∅
70	18.7	8.7	11.7	4.5	0.5	5.7	M5	5 H7	M5	5 H7

Size	D6	H1	H2	H3	L1	L2	L3	L4	L5	L6
70	M4	35	17.5	±0.1	±0.1	±0.1	±0.1	±0.03	10	56

Size	L7	L8	L9	L10	L11	T1	T2	T3	T4
70	±0.1	±0.2					+0.1		
70	40	190	212.1	224.1	30	7.5	3.1	10	6

Data sheet

Dimensions

Download CAD data → www.festo.com

GV-C – Extended slide with lubrication adapter

Size 80

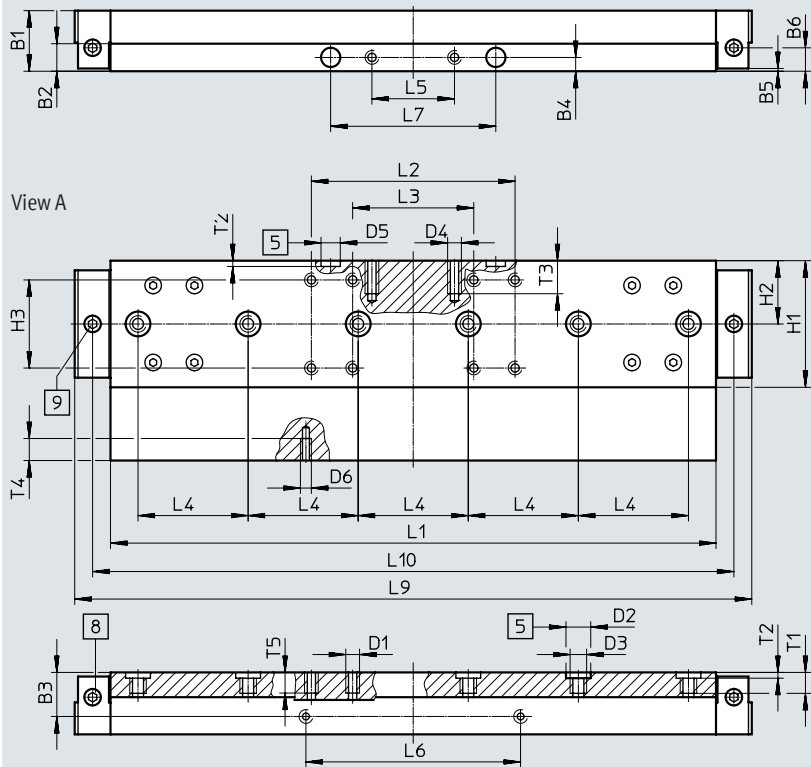

- [5] Drill hole for centring sleeve
- [6] Drilled hole for centring pin
- [8] Lubricating hole for lubrication adapter
M6 threaded connection, 6 mm deep
- [9] Lubricating hole for lubrication adapter
M6 threaded connection, 5.5 mm deep

Size	B1	B2	B3	B4	B5	B6	D1	D2 ∅ H7	D3	D4
70	22	10	16	5	±0.1 1	8.5	M5	9	M6	M5

Size	D5 ∅ H7	D6	H1	H2	H3	L1	L2	L3	L4	L5
70	7	M4	46	23	±0.2 32	±0.1 220	±0.2 74	±0.2 44	±0.03 40	±0.1 30

Size	L6	L7	L9	L10	L11	T1	T2	T3	T4	T5
70	±0.1 78	±0.05 60	246	233	30	8.6	+0.1 2.1	12	7	7.5

Data sheet

Dimensions

Download CAD data → www.festo.com

GV-C – Extended slide with lubrication adapter

Size 120

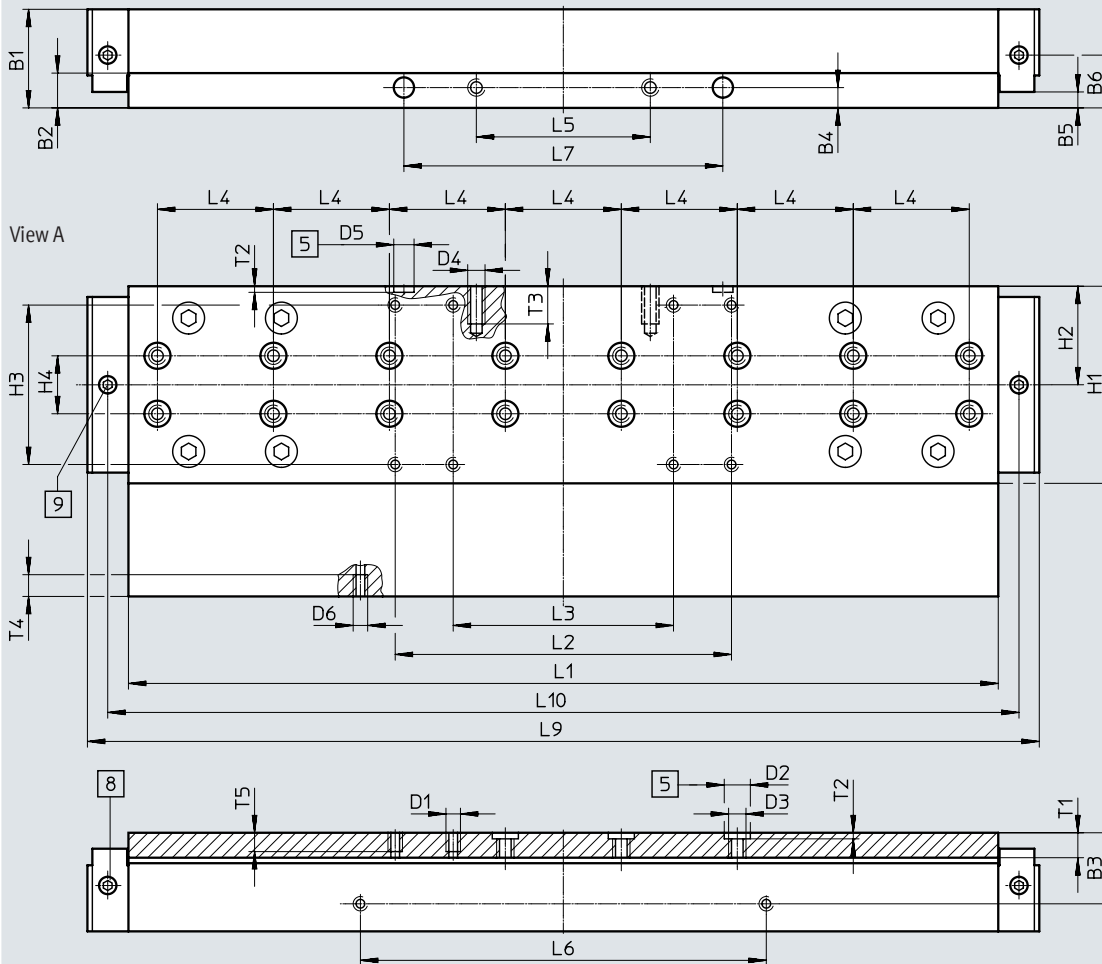

- [5] Drill hole for centring sleeve
- [8] Lubricating hole for lubrication adapter
M6 threaded connection, 6 mm deep
- [9] Lubricating hole for lubrication adapter
M6 threaded connection, 5.5 mm deep

Size	B1	B2	B3	B4	B5	B6	D1	D2 ∅ H7	D3	D4
120	34	12	24.5	7	5.5	13.9	M5	9	M6	M6

Size	D5 ∅ H7	D6	H1	H2	H3	H4	L1	L2	L3	L4
120	7	M5	68	34	55	20	300	116	76	40

Size	L5	L6	L7	L9	L10	T1	T2	T3	T4	T5
120	±0.1	±0.1	±0.05	328.3	314.3	8.6	+0.1	13	8	7.5

Data sheet

Dimensions

Download CAD data → www.festo.com

GV-C – Extended slide with lubrication adapter

Size 185

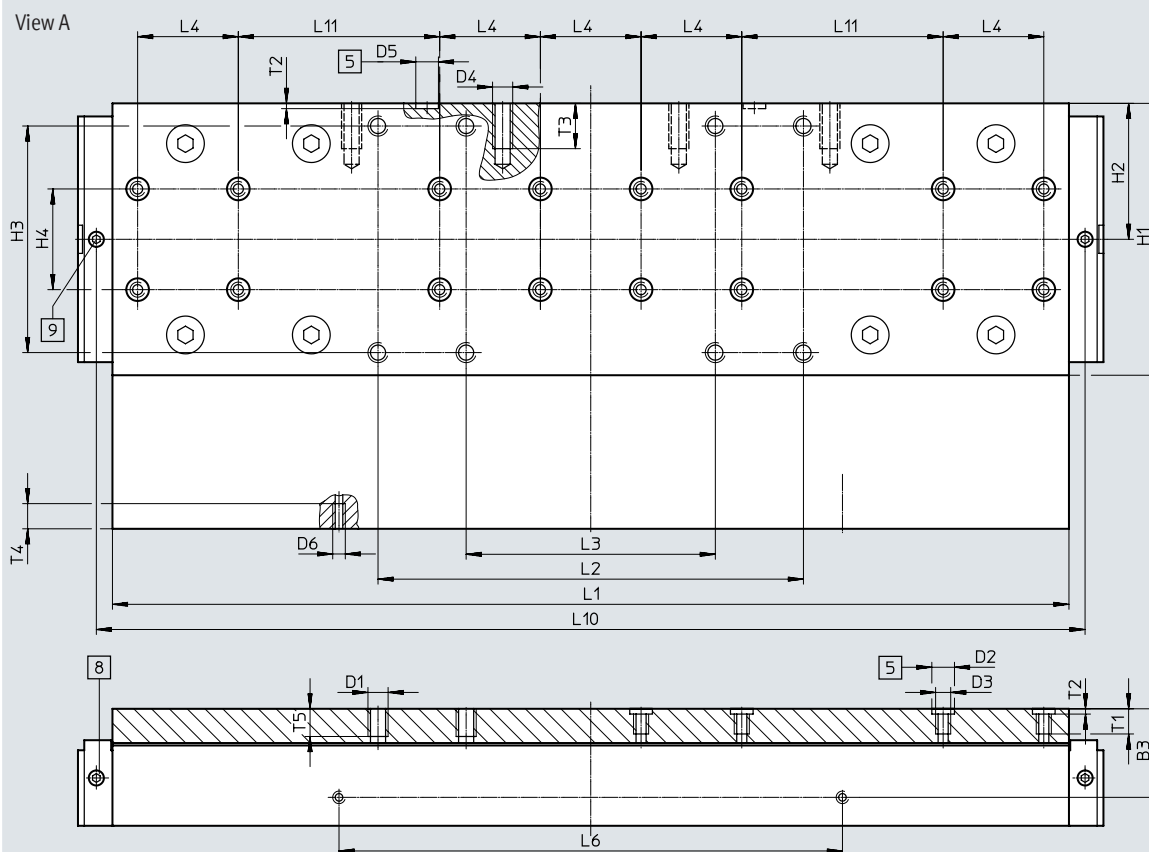
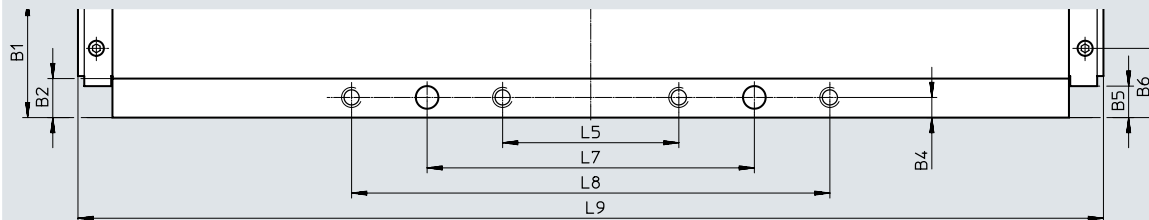

- [5] Drill hole for centring sleeve
- [8] Lubricating hole for lubrication adapter
M6 threaded connection, 6 mm deep
- [9] Lubricating hole for lubrication adapter
M6 threaded connection, 5.5 mm deep

Size	B1	B2	B3	B4	B5	B6	D1	D2 ∅ H7	D3	D4	D5 ∅ H7
185	46.5	15.5	35.2	8	±0.1 12.5	27.5	M8	9	M6	M8	9

Size	D6	H1	H2	H3	H4	L1	L2	L3	L4	L5	L6
185	M5	108	54	±0.2 90	±0.03 40	380	±0.2 169	±0.2 99	±0.03 40	±0.2 70	±0.1 200

Size	L7	L8	L9	L10	L11	T1	T2	T3	T4	T5
185	±0.05 130	±0.2 190	407.4	392.8	±0.03 80	11	+0.1 2.1	18	10	12

Data sheet

Dimensions

Download CAD data → www.festo.com

1HL/1HR/2H – With clamping unit

Size 80

1-channel, left

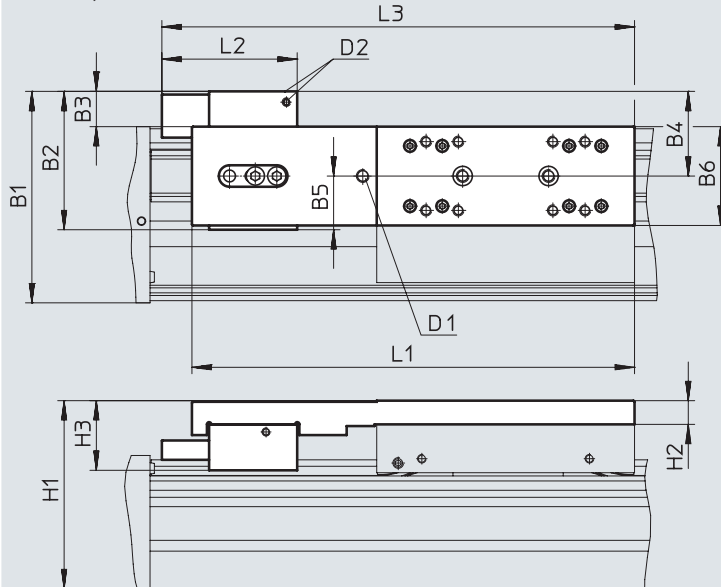

1-channel, right

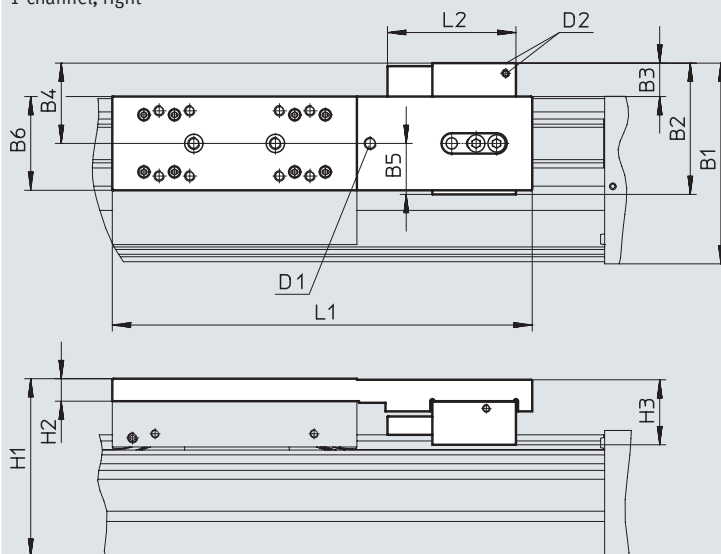

D2 Compressed air supply port

Data sheet

Dimensions

Download CAD data → www.festo.com

1HL/1HR/2H – With clamping unit

Size 80

2-channel

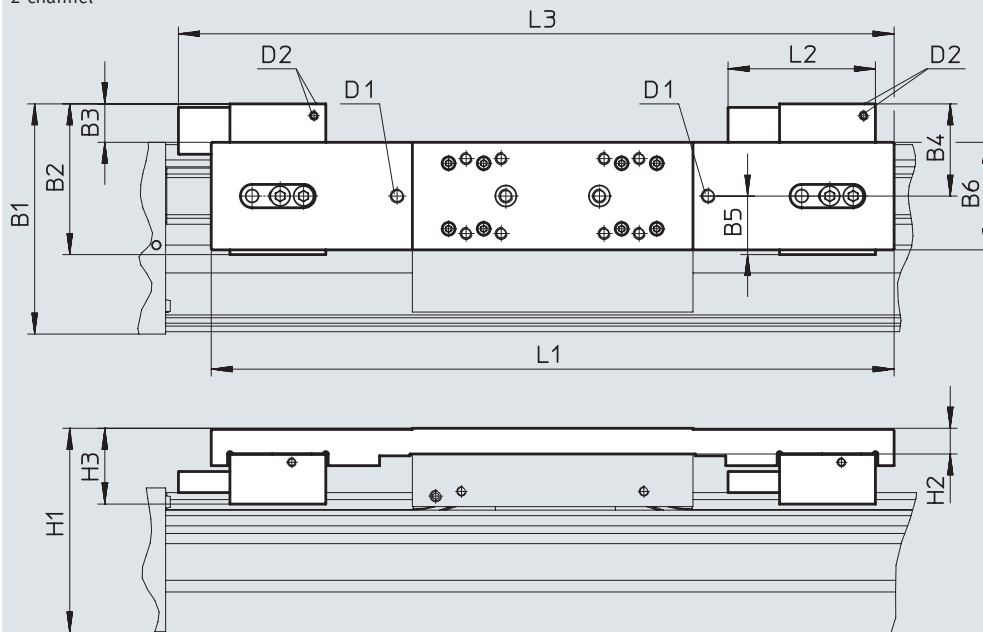

D2 Compressed air supply port

Type	B1	B2	B3	B4	B5	B6	H1	H2	H3	D1	D2	L1	L2	L3
EGC-80-...-1HL-PN	98.4	64.4	17.4	39.4	25	46	87.5	11	32.4	M6	M5	206	63	220
EGC-80-...-1HR-PN														-
EGC-80-...-C-1HL-PN														220
EGC-80-...-C-1HR-PN														-
EGC-80-...-2H-PN														306
EGC-80-...-C-2H-PN												292		

Data sheet

Dimensions

Download CAD data → www.festo.com

1HL/1HR/2H – With clamping unit

Size 120/185

1-channel, left

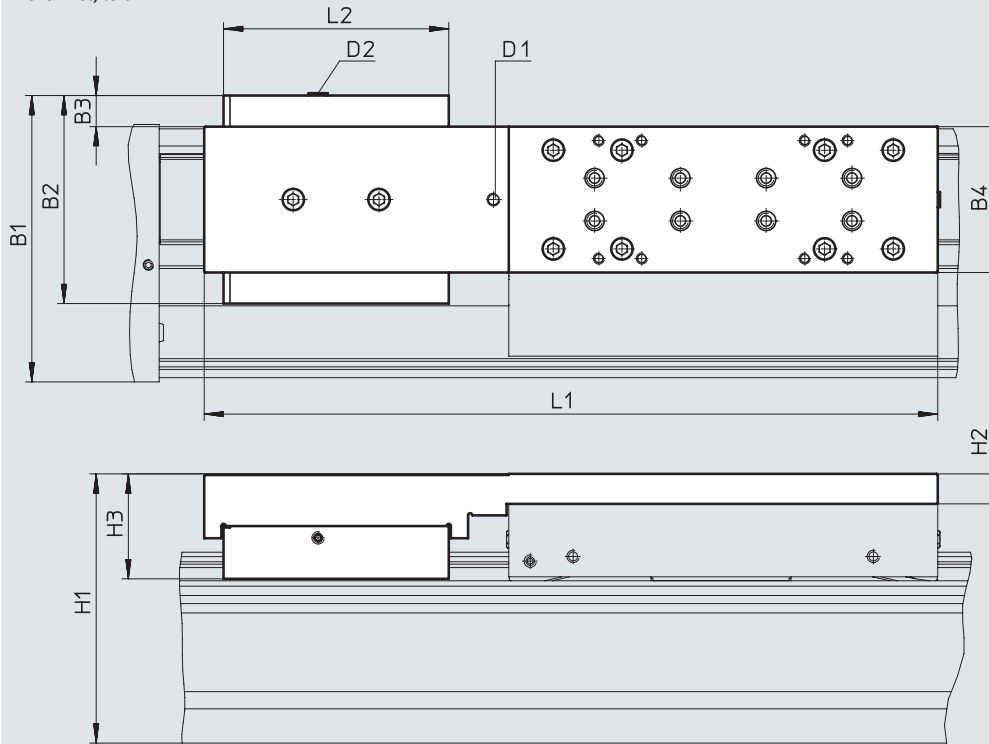

1-channel, right

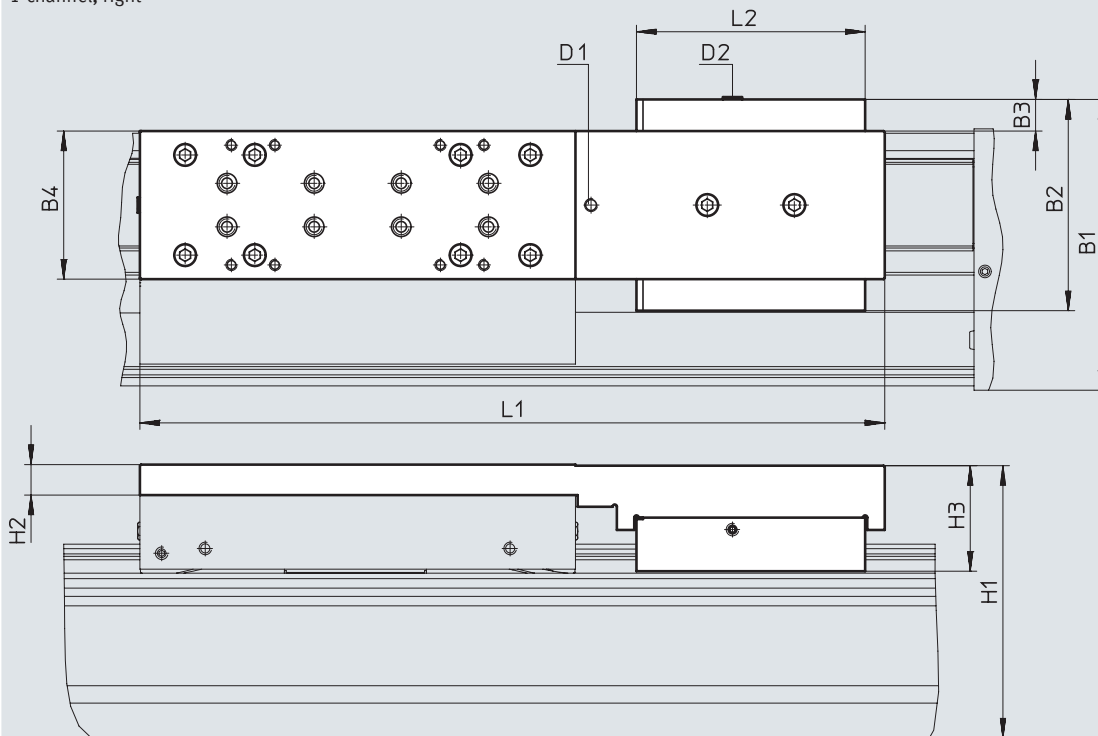

D2 Compressed air supply port

Data sheet

Dimensions

Download CAD data → www.festo.com

1HL/1HR/2H – With clamping unit

Size 120/185

2-channel

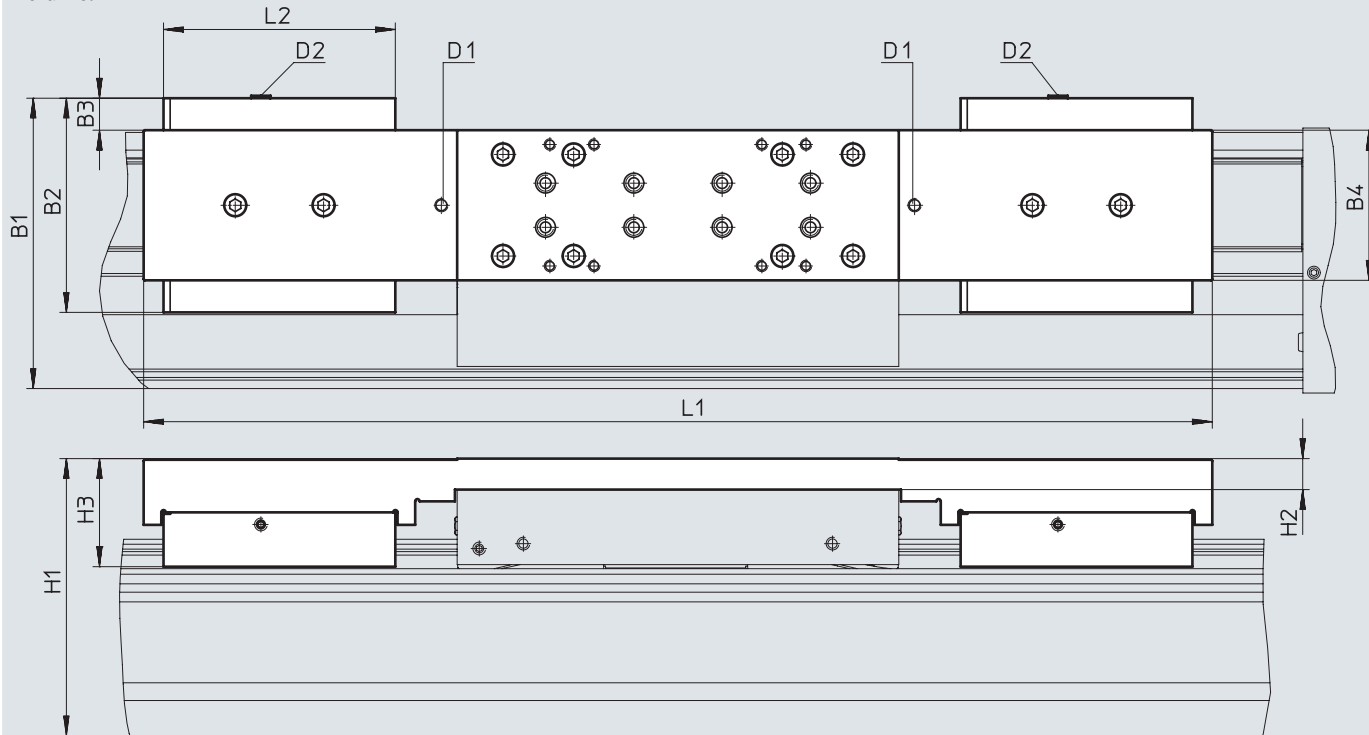

D2 Compressed air supply port

Type	B1	B2	B3	B4	H1	H2	H3	D1	D2	L1	L2
Size 120											
EGC-120-...-1HL-PN	133.5	97	15.5	68	125.5	14	48.9	M6	M5	342	105
EGC-120-...-1HR-PN											
EGC-120-...-C-1HL-PN											
EGC-120-...-C-1HR-PN											
EGC-120-...-2H-PN										484	
EGC-120-...-C-2H-PN											
Size 185											
EGC-185-...-1HL-PN	196.5	131	12.5	108	189.5	17	64.1	M6	M5	432	109
EGC-185-...-1HR-PN											
EGC-185-...-C-1HL-PN											
EGC-185-...-C-1HR-PN											
EGC-185-...-2H-PN										584	
EGC-185-...-C-2H-PN											

Ordering data – Modular product system

Order code

Mandatory data

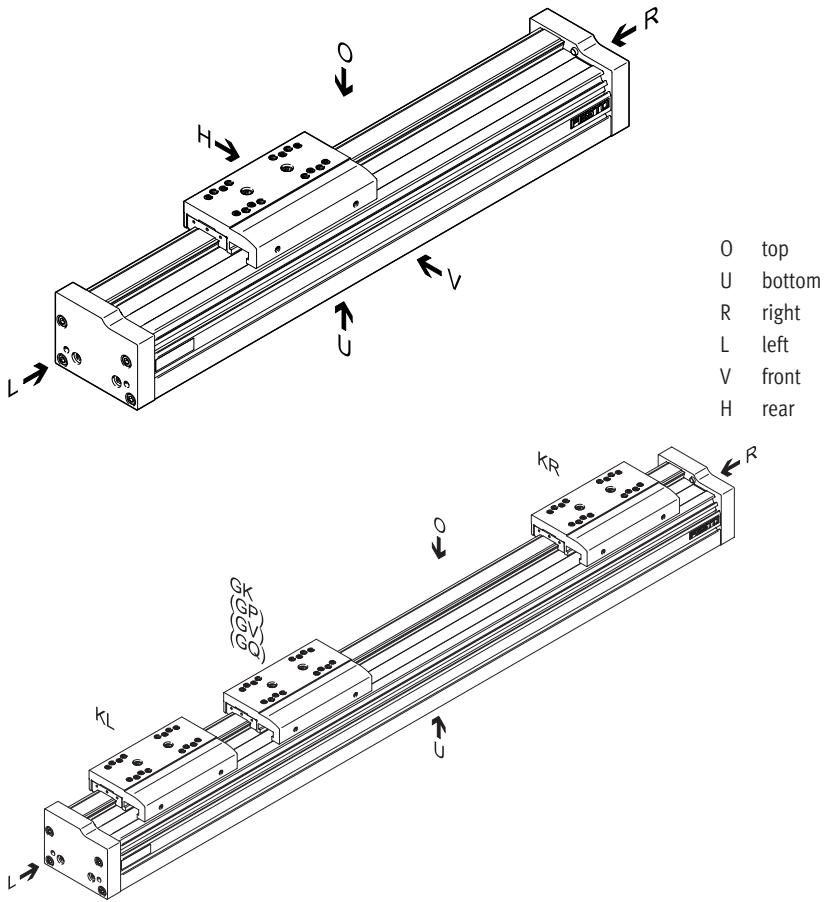

Ordering data – Modular product system

Order code

Accessories

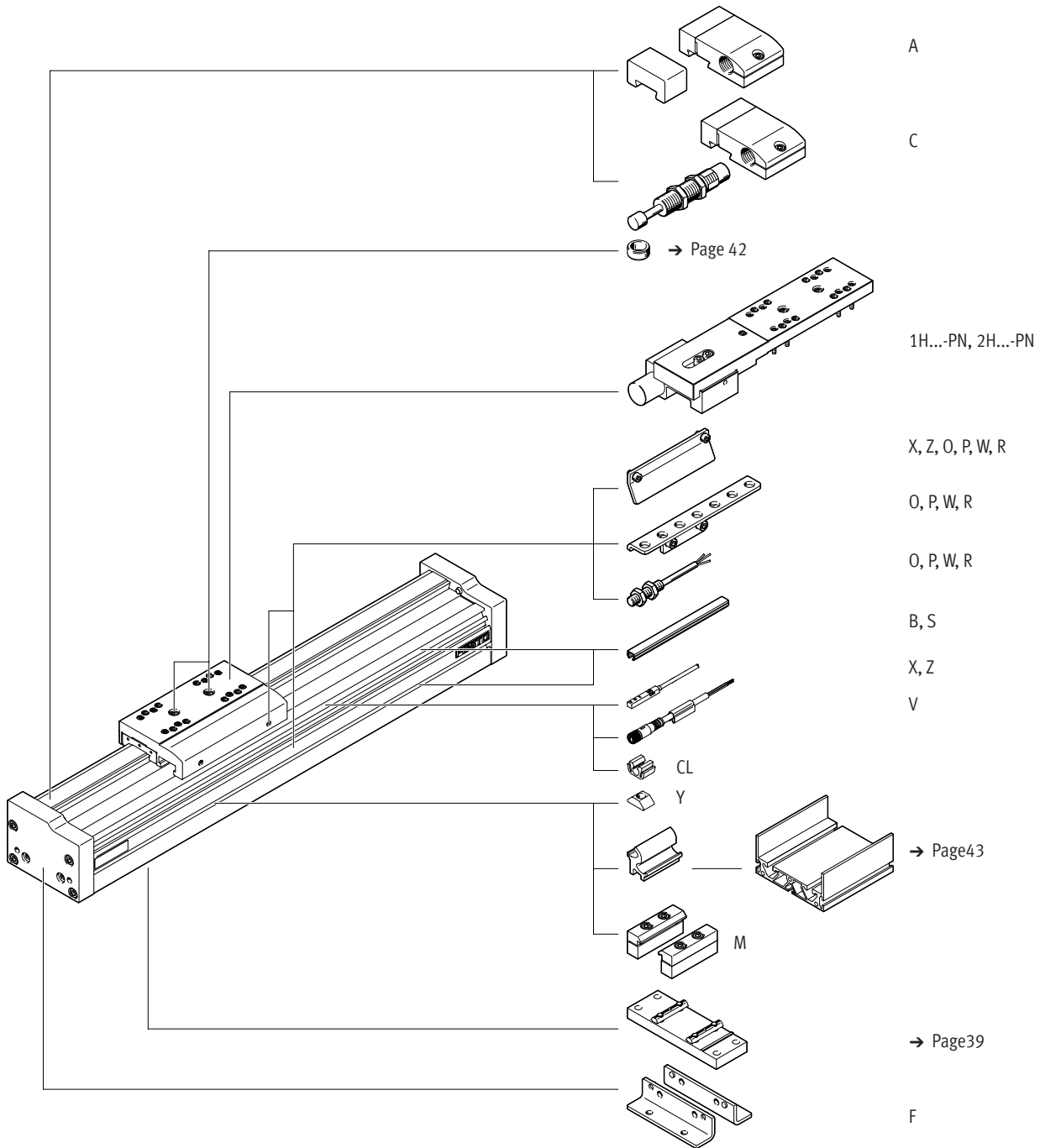

Ordering data – Modular product system

Ordering table							
Size	70	80	120	185	Conditions	Code	Enter code
Module no.	558864	558865	558866	558868			
Design	Guide axis					EGC	EGC
Size	70	80	120	185		-...	-...
Stroke [mm]	50 ... 5000	50 ... 8500	50 ... 8500	50 ... 8500	[1]	-...	-...
Guide	Guide axis					-FA	-FA
Stroke reserve [mm]	0 ... 999 (0 = no stroke reserve)				[1]	-...H	
Slide	Standard slide					-GK	
	Extended slide, protected			-		-GQ	
	Standard slide, protected			-		-GP	
	Extended slide					-GV	
Additional slide	Left	Additional slide, standard, left			[2]	-KL	
	Right	Additional slide, standard, right			[2]	-KR	
Lubrication function	Standard						
	Lubrication adapter				[6]	-C	
Clamping unit	-	1-channel, left		[3]	-1HL		
	-	1-channel, right		[3]	-1HR		
	-	2-channel		[3]	-2H		
Actuation type	-	Pneumatic			-PN		

- [1] -... The sum of the stroke length and 2x stroke reserve must not exceed the maximum stroke length
- [2] KL, KR If the protected slide variant (GP) is selected, the additional slide is also protected
If the slide with lubrication adapter (GK-C) is selected, the additional slide (KL, KR) is also supplied with lubrication adapter
Working stroke reduction in combination with additional slide (K) → page 10
- [3] 1HL, 1HR, 2H Not with additional slide K
Only with PN
Working stroke reduction in combination with clamping unit (1HL, 1HR, 2H) → page 10
- [6] CNot with slide GP, GQ

Ordering data – Modular product system

Ordering table		70	80	120	185	Conditions	Code	Enter code
Size								
Accessories		Accessories enclosed separately					ZUB-	ZUB-
Foot mounting		1					F	
Profile mounting		1 ... 50					...M	
Cover	Mounting slot	1 ... 50 (1 = 2 units, 500 mm length)					...B	
	Sensor slot	1 ... 50 (1 = 2 units, 500 mm length)					...S	
Slot nut for mounting slot		1 ... 99					...Y	
Proximity switch (SIES), inductive, slot type 8, PNP, incl. switch lug	N/O contact, 7.5 m cable	1 ... 6					...X	
	N/C contact, 7.5 m cable	1 ... 6					...Z	
Emergency buffer with retaining bracket		1 ... 2				[4]	...A	
Shock absorber with retaining bracket		1 ... 2				[5]	...C	
Proximity switch (SIEN), inductive, M8, PNP, incl. switch lug with sensor bracket	N/O contact, 2.5 m cable	1 ... 99					...O	
	N/C contact, 2.5 m cable	1 ... 99					...P	
	N/O contact, M8 plug	1 ... 99					...W	
	N/C contact, M8 plug	1 ... 99					...R	
Plug socket with cable 2.5 m, M8, 3-wire		1 ... 99					...V	
Cable clip		10, 20, 30, 40, 50, 60, 70, 80, 90					...CL	
Operating instructions		Express waiver – no operating instructions to be included as they are already available (operating instructions in PDF format are available free of charge on the Internet at www.festo.com)					-DN	

[4] ... A Emergency buffer with retaining bracket A cannot be combined with slide GP, GK-C, shock absorber with retaining bracket C and clamping unit 1H...-PN, 2H-PN

[5] ... C Shock absorber with retaining bracket C cannot be combined with slide GP, GK-C, emergency buffer with retaining bracket A and clamping unit 1H...-PN, 2H-PN

 **Note**

The code X, Z includes a switch lug in the scope of delivery. The code O, P, W, R includes one switch lug and max. two sensor brackets in the scope of delivery.

Accessories

Foot mounting HPE (order code F)

Material:
Galvanised steel
RoHS-compliant

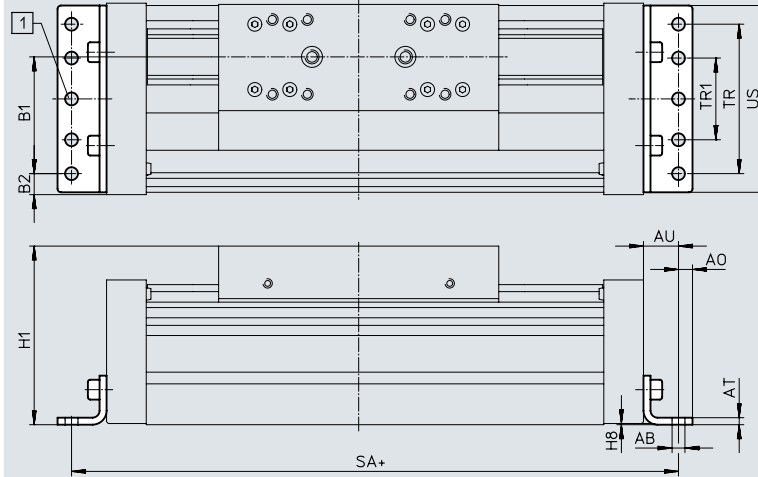

[1] Drilled hole for HPE-120
+ = plus stroke length + 2x stroke reserve

Dimensions and ordering data

For size	AB ∅	A0	AT	AU	B1	B2	H1	H8
70	5.5	6	3	13	37	14.5	64	0.5
80	5.5	6	3	15	38	21	76.5	0.5
120	9	8	6	22	65	20	111.5	0.6
185	9	12	8	25	118	13	172.5	0.5

For size	SA	TR	TR1	Us	Weight [g]	Part no.	Type
70	189	40	–	67	115	558321	HPE-70
80	220	40	–	80	150	558322	HPE-80
120	350	80	–	116	578	558323	HPE-120
185	456	160	80	182	1438	558325	HPE-185

Accessories

Profile mounting MUE (order code M)

Material:
Anodised aluminium
RoHS-compliant

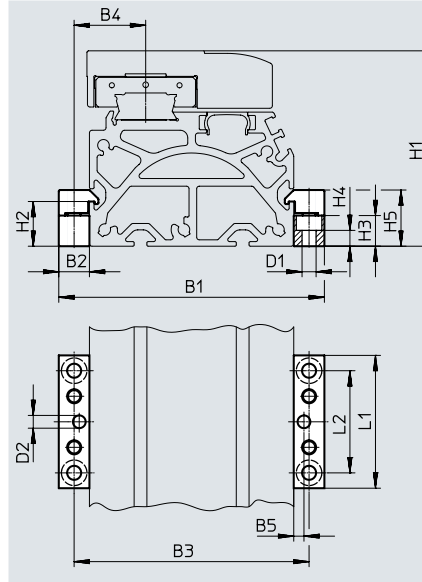

Dimensions and ordering data

For size	B1	B2	B3	B4	B5	D1 ∅	D2 ∅ H7	H1	H2
70	91	12	79	22.5	4	5.5	5	64	17.5
80	104	12	92	28	4	5.5	5	76.5	17.5
120	154	19	135	42.5	4	9	5	111.5	16
185	220	19	201	62.5	4	9	5	172.5	16

For size	H3	H4	H5	L1	L2	Weight [g]	Part no.	Type
70	12	6.2	22	52	40	80	558043	MUE-70/80
80	12	6.2	22	52	40	80	558043	MUE-70/80
120	14	5.5	29.5	90	40	290	558044	MUE-120/185
185	14	5.5	29.5	90	40	290	558044	MUE-120/185

Accessories

Central support EAHF

Material:
Anodised aluminium
RoHS-compliant



Size 70, 80

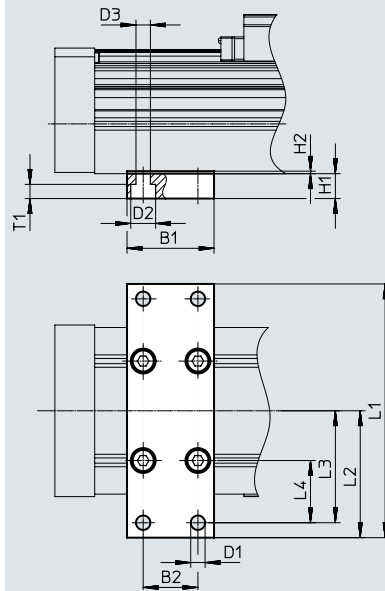

Size 120

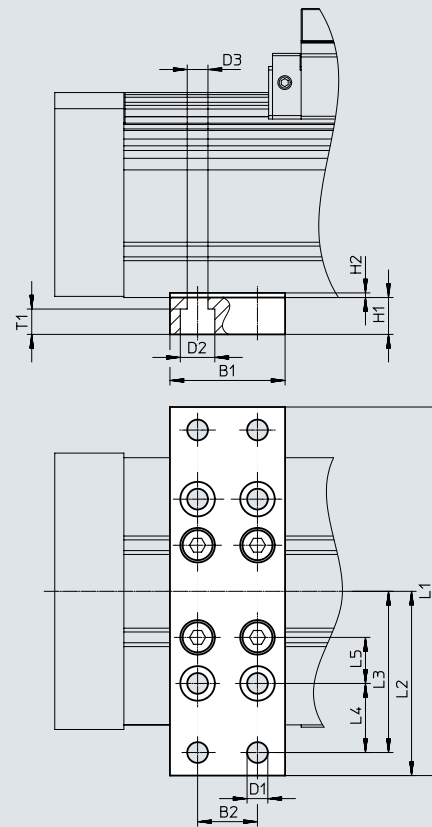

Dimensions and ordering data

For size	B1	B2	D1 ∅	D2 ∅	D3 ∅	H1	L1
70	35	22	5.8	10	5.8	10	102
80							112
120	50	26	9	15	9	16	160

For size	L2	L3	L4	L5	T1	Weight [g]	Part no.	Type
70	51	45	25	-	5.7	113	2349256	EAHF-L5-70-P
80	56	50	30			123	3535188	EAHF-L5-80-P
120	80	70	30	20	11	384	2410274	EAHF-L5-120-P

Accessories

Shock absorber retainer KYE

Emergency buffer NPE → page 42

Shock absorber YSRW → page 42

(order code A or C)

Material:

Anodised aluminium

RoHS-compliant

Cannot be used in combination with

the variant GP or GK-C and 1H...-PN,
2H-PN.

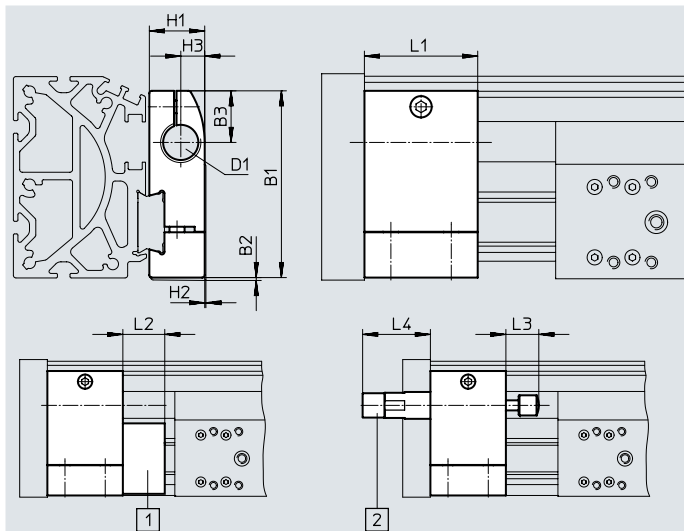

[1] Emergency buffer NPE

[2] Shock absorber YSRW

Dimensions and ordering data

For size	B1	B2	B3	D1	H1	H2	H3	L1	L2	L3	L4	Weight [g]	Part no.	Type
70	57.5	1	16.5	M12X1	18.2	0.5	7.5	30	15	14	32	75	557584	KYE-70
80	74.2	1	20.5	M16X1	22	0.5	9.5	45	25	20	41	170	557585	KYE-80
120	108.5	1	26	M22X1.5	31	1	14	60	40	26	48.5	680	557586	KYE-120
185	168	1	37	M26X1.5	42	4	18	75	60	34	58.5	1075	557587	KYE-185

Switch lug SF-EGC-1

For sensing via proximity switch

SIES-8M

(order code X or Z)

Material:

Galvanised steel

RoHS-compliant

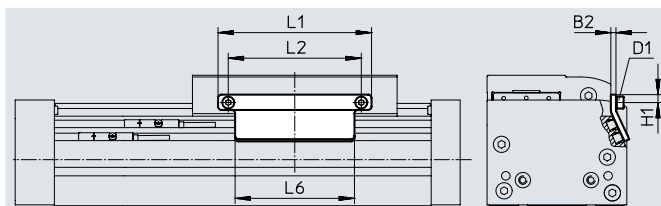

Dimensions and ordering data

For size	B2	D1	H1	L1	L2	L6	Weight [g]	Part no.	Type
70	3	M4	4.65	70	56	50	50	558047	SF-EGC-1-70
80	3	M4	4.65	90	78	70	63	558048	SF-EGC-1-80
120	3	M5	8	170	140	170	147	558049	SF-EGC-1-120
185	3	M5	10	230	200	230	246	558051	SF-EGC-1-185

Accessories

Switch lug SF-EGC-2

For sensing via proximity switch SIEN-M8B (order code O, P, W or R) or SIES-8M (order code X or Z)

Material:
Galvanised steel
RoHS-compliant

Sensor bracket HWS-EGC

For proximity switch SIEN-M8B (order code O, P, W or R)

Material:
Galvanised steel
RoHS-compliant

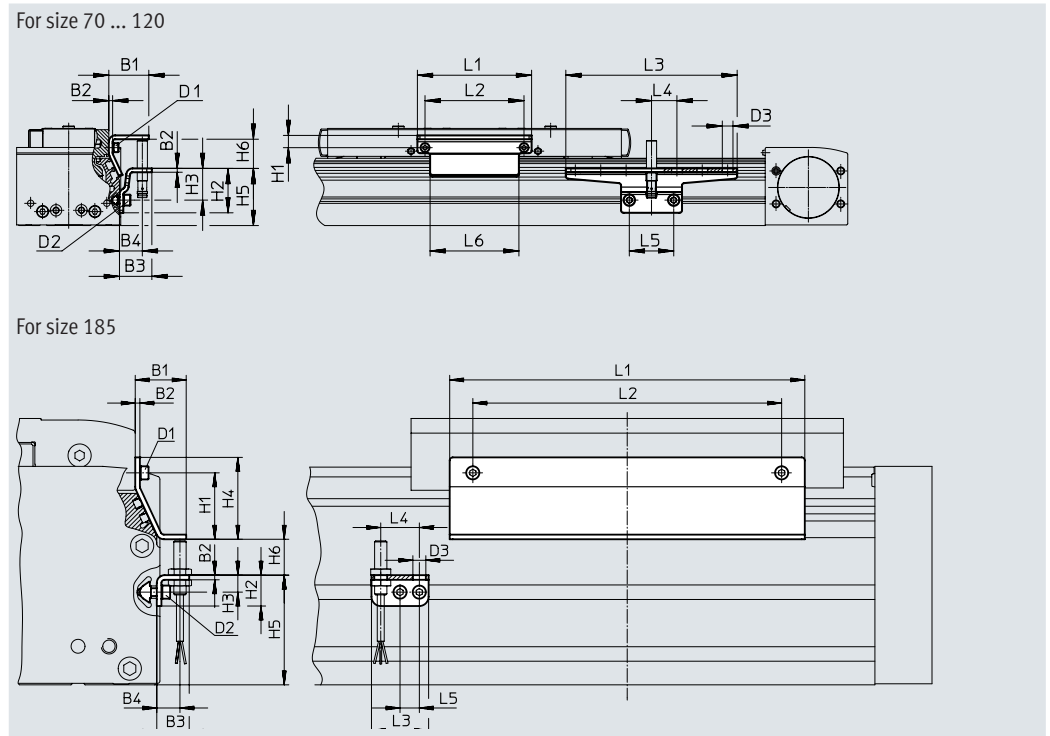

Dimensions and ordering data







For size	B1	B2	B3	B4	D1	D2	D3 ∅	H1	H2
70	31.5	3	25.5	18	M4	M5	8.4	9.5	35
80	31.5	3	25.5	18	M4	M5	8.4	9.5	35
120	32	3	25.5	18	M5	M5	8.4	13.2	65
185	33	3	25.5	15	M5	M5	8.4	43	20

For size	H3	H4	H5	H6 max.	L1	L2	L3	L4	L5	L6
70	25	–	45	13.5	70	56	135	20	35	50
80	25	–	45	23.5	90	78	135	20	35	70
120	55	–	75	24	170	140	215	20	35	170
185	11	53	71	25.5	230	200	37	25	12.5	230

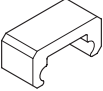
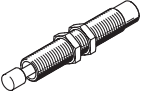
For size	Weight [g]	Part no.	Type
Switch lug			
70	100	558052	SF-EGC-2-70
80	130	558053	SF-EGC-2-80
120	277	558054	SF-EGC-2-120
185	390	558056	SF-EGC-2-185

For size	Weight [g]	Part no.	Type
Sensor bracket			
70	110	558057	HWS-EGC-M5
80	110	558057	HWS-EGC-M5
120	217	570365	HWS-EGC-M8-B
185	58	560517	HWS-EGC-M8:KURZ (SHORT)

Accessories

Ordering data		For size	Description	Order code	Part no.	Type	PU ¹⁾
Emergency buffer NPE							
	70	For use in combination with shock absorber retainer KYE	A	562581	NPE-70		1
	80			562582	NPE-80		
	120			562583	NPE-120		
	185			562584	NPE-185		
Shock absorber YSRW Data sheets → Internet: ysrw							
	70	For use in combination with shock absorber retainer KYE	C	191194	YSRW-8-14		1
	80			191196	YSRW-12-20		
	120			191197	YSRW-16-26		
	185			191198	YSRW-20-34		
Slot nut NST							
	70, 80	For mounting slot	Y	150914	NST-5-M5		1
				8047843	NST-5-M5-10		10
				8047878	NST-5-M5-50		50
	120, 185	For mounting slot	Y	150915	NST-8-M6		1
				8047868	NST-8-M6-10		10
				8047869	NST-8-M6-50		50
Centring pin/sleeve ZBS/ZBH							
	70	For slide	-	150928	ZBS-5		10
	80, 120, 185			8137184	ZBH-9-B		
Slot cover ABP							
	70, 80	For mounting slot Each 0.5 m	B	151681	ABP-5		2
	120, 185			151682	ABP-8		
Slot cover ABP-S							
	70 ... 185	For sensor slot Each 0.5 m	S	563360	ABP-5-S1		2
Clip SMBK							
	70 ... 185	For sensor slot, for mounting the proximity switch cables	CL	534254	SMBK-8		10

1) Packaging unit

Accessories

Mounting options between axis and support profile

Depending on the adapter kit, the spacing between the axis and the support profile is:
x = 20 mm or 50 mm

The support profile must be mounted using at least 2 adapter kits. For longer strokes, an adapter kit must be used every 500 mm.

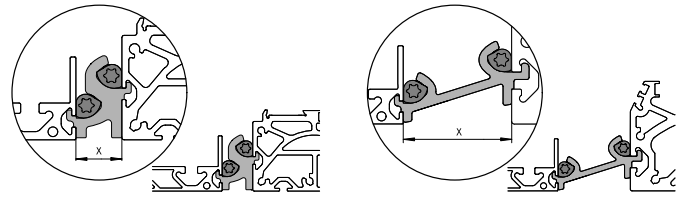

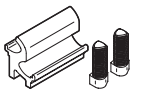
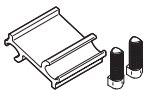
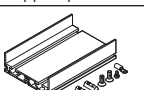
Ordering data					
	For size	Description	Part no.	Type	PU ¹⁾
Adapter kit DHAM					
	80	<ul style="list-style-type: none"> For mounting the support profile on the axis Spacing between axis and profile is 20 mm 	562241	DHAM-ME-N1-CL	1
	120		562242	DHAM-ME-N2-CL	
	70, 80	<ul style="list-style-type: none"> For mounting the support profile on the axis Spacing between axis and profile is 50 mm 	574560	DHAM-ME-N1-50-CL	
	120		574561	DHAM-ME-N2-50-CL	
Support profile HMIA					
	70 ... 120	<ul style="list-style-type: none"> For guiding an energy chain 	539379	HMIA-E07-	1

1) Packaging unit

Ordering data – Proximity switches for T-slot, inductive

Data sheets → Internet: sies

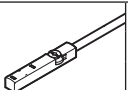
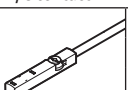

	Type of mounting	Electrical connection	Switching output	Cable length [m]	Order code	Part no.	Type
N/O contact							
	Inserted in the slot from above, flush with the cylinder profile	Cable, 3-wire	PNP	7.5	X	551386	SIES-8M-PS-24V-K-7.5-OE
		Plug M8x1, 3-pin		0.3		551387	SIES-8M-PS-24V-K-0.3-M8D
		Cable, 3-wire	NPN	7.5	-	551396	SIES-8M-NS-24V-K-7.5-OE
		Plug M8x1, 3-pin		0.3		551397	SIES-8M-NS-24V-K-0.3-M8D
N/C contact							
	Inserted in the slot from above, flush with the cylinder profile	Cable, 3-wire	PNP	7.5	Z	551391	SIES-8M-PO-24V-K-7.5-OE
		Plug M8x1, 3-pin		0.3		551392	SIES-8M-PO-24V-K-0.3-M8D
		Cable, 3-wire	NPN	7.5	-	551401	SIES-8M-NO-24V-K-7.5-OE
		Plug M8x1, 3-pin		0.3		551402	SIES-8M-NO-24V-K-0.3-M8D

Accessories

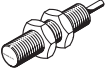
Ordering data – Proximity switch M8 (round design), inductive							Data sheets → Internet: sien
	Electrical connection	LED	Switching output	Cable length [m]	Order code	Part no.	Type

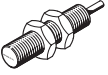
N/O contact							
	Cable, 3-wire	■	PNP	2.5	O	150386	SIEN-M8B-PS-K-L
	Plug M8x1, 3-pin	■	PNP	–	W	150387	SIEN-M8B-PS-S-L

N/C contact							
	Cable, 3-wire	■	PNP	2.5	P	150390	SIEN-M8B-PO-K-L
	Plug M8x1, 3-pin	■	PNP	–	R	150391	SIEN-M8B-PO-S-L

Ordering data – Connecting cables						Data sheets → Internet: nebu
	Electrical connection, left	Electrical connection, right	Cable length [m]	Part no.	Type	
	Straight socket, M8x1, 3-pin	Cable, open end, 3-wire	2.5	159420	SIM-M8-3GD-2.5-PU	
			2.5	541333	NEBU-M8G3-K-2.5-LE3	
			5	541334	NEBU-M8G3-K-5-LE3	
	Angled socket, M8x1, 3-pin	Cable, open end, 3-wire	2.5	541338	NEBU-M8W3-K-2.5-LE3	
			5	541341	NEBU-M8W3-K-5-LE3	

Festo - Your Partner in Automation



1 Festo Inc.
5300 Explorer Drive
Mississauga, ON L4W 5G4
Canada

Festo Customer Interaction Center
Tel: 1 877 463 3786
Fax: 1 877 393 3786
Email: customer.service.ca@festo.com

2 Festo Pneumatic
Av. Ceylán 3,
Col. Tequesquináhuac
54020 Tlalnepantla,
Estado de México

Multinational Contact Center
01 800 337 8669
ventas.mexico@festo.com

3 Festo Corporation
1377 Motor Parkway
Suite 310
Islandia, NY 11749

Festo Customer Interaction Center
1 800 993 3786
1 800 963 3786
customer.service.us@festo.com

4 Regional Service Center
7777 Columbia Road
Mason, OH 45040

Connect with us



www.festo.com/socialmedia



www.festo.com

Subject to change