

Quarter turn actuator unit KDFP

FESTO

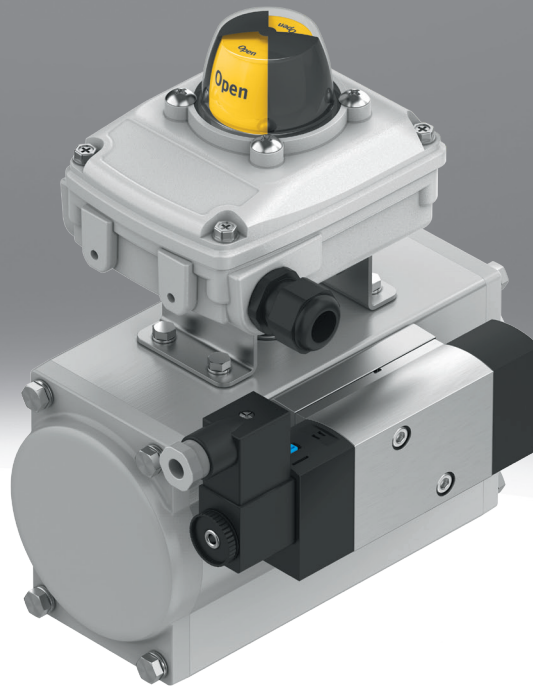

Characteristics

At a glance

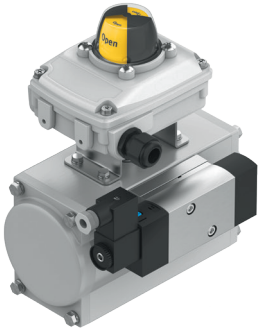

The new configurator provides support with the high number of requests for customised quarter turn actuator units that are handled by the Project Engineering department. Finding and selecting suitable quarter turn actuator units, selecting their dimensions and ordering them is now possible without waiting times. Access to prices and delivery times is available immediately after configuration. Likewise for configuration-specific data sheets, 2DCAD data and 3DCAD models in many native and neutral formats and, of course, the certifications of the complete units.

Ordering data - modular system

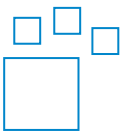

Configurable product

This product and all its product options can be ordered online via the configurator.

EX certification



II 2GD

ATEX category for gas II 2G

Type of ignition protection for gas c T6 ... T3 X

ATEX category for dust II 2D

Type of ignition protection for dust c T80 °C ... T200 °C X

Explosion-proof ambient temperature rating $0^{\circ}\text{C} \leq T_a \leq +60^{\circ}\text{C}$

Further information can be found in the documentation

Application

Controlled

The required position of the process valve is specified via an analogue positioning signal, e.g. 4 ... 20 mA.

Open/closed

The process valve is moved into both end positions.

Position indicator

The actual end position of the process valve unit can be transmitted either visually, directly on the process valve or via an electrical signal.

Characteristics

Pilot valve

The pneumatic pilot valve is mounted directly on the quarter turn actuator via the NAMUR interface.

Standard version

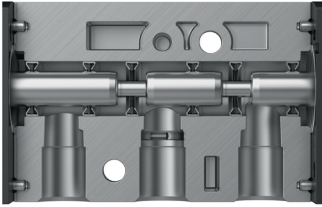

A pneumatic pilot valve, with the design principle of a piston slide, is mounted directly on the quarter turn actuator via the NAMUR interface. The piston slide design is the first choice for all standard applications. The technology enables overlap-free switching and, compared to the poppet valve, has a greater flow rate with the same connection size.

Poppet valve version

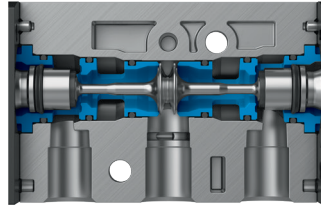

A pneumatic pilot valve, with the design principle of a poppet valve, is mounted directly on the quarter turn actuator via the NAMUR interface. The advantages of the poppet valve design come into their own when the demands on the application increase. They include greater tolerance against "dirty" compressed air, reduced leakages and fewer dynamic seals, which has an impact on service life.

Breakaway torque

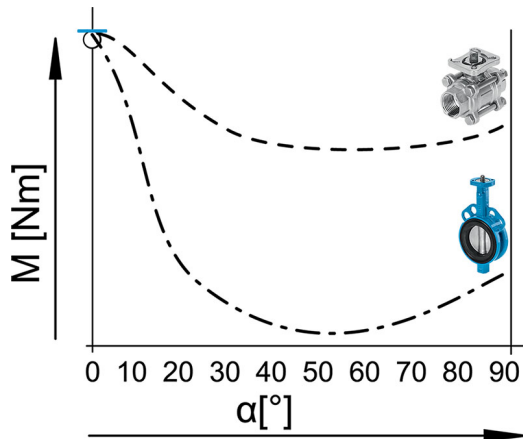

Torque required to overcome the static friction of the process valve.

Characteristics

Flange hole pattern

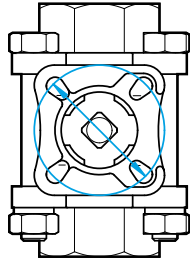
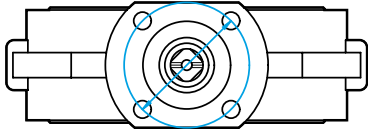

Flange hole pattern F03 = diameter 36 mm

Flange hole pattern F04 = diameter 42 mm

Flange hole pattern F05 = diameter 50 mm

Flange hole pattern F07 = diameter 70 mm

Flange hole pattern F10 = diameter 102 mm

Flange hole pattern F12 = diameter 125 mm

Flange hole pattern F14 = diameter 140 mm

Flange hole pattern F16 = diameter 165 mm

Flange hole pattern F25 = diameter 254 mm

Flange hole pattern F30 = diameter 298 mm

Width across flats

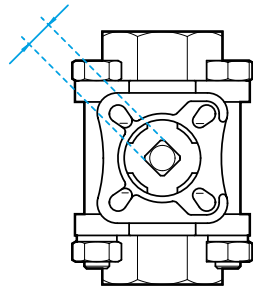
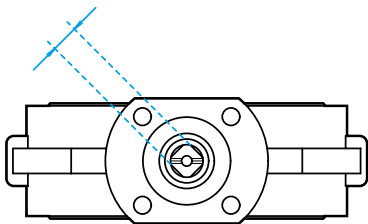

Characteristics

Shaft length

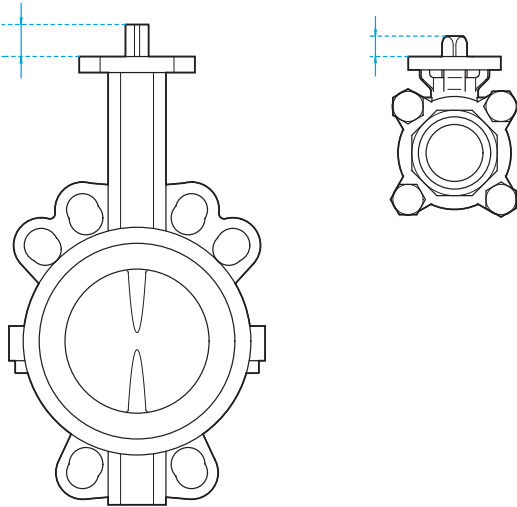

Valve type

Butterfly valve

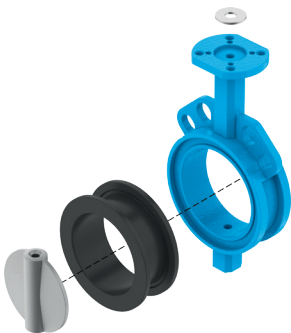

Design with centring holes for installation between two pipe flanges, alternatively with threaded flange holes for installation between two pipe flanges or at the end of a pipeline, one-sided disconnection possible.

Ball valve

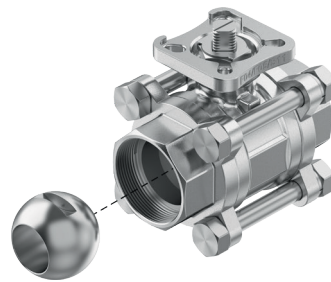

Design with flange, threaded connection, terminal or weld-on ends

Mode of operation

Double-acting

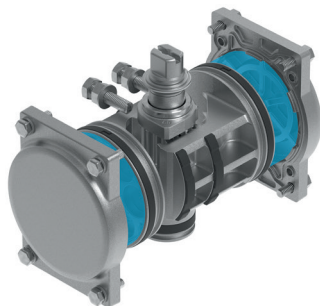

The double-acting quarter turn actuator requires compressed air for each direction of movement. In this mode of operation, the torque for opening or closing the process valve is generated purely via the compressed air.

Single-acting

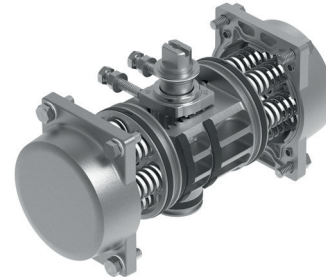

With the single-acting quarter turn actuator, the incoming compressed air moves the pistons in one direction. This generates the torque of the actuator. At the same time, the springs built into the actuator are pre-tensioned. This spring force generates the torque in the opposite direction of rotation when the pressure chambers of the actuator are exhausted. This causes the angle seat fitting to move to the required initial position.

Characteristics

Safety function

Return to normal position

The valve is moved to the selected normal position if the system fails. Note: The selection of the operating mode (double-acting or single-acting) has a decisive influence on when the safety function is carried out.

“Double-acting” operating mode: this function is carried out by a 5/2-way single solenoid pilot valve. The valve is only moved to the normal position if the operating voltage fails, but not if the compressed air supply fails.

- Single-acting” operating mode: this function is carried out by a 3/2-way single solenoid pilot valve. If the operating voltage or compressed air supply fails, the valve is moved to the normal position by the spring force of the actuator.

Hold position with 5/2B pilot valve

The valve is held in the current position if the operating voltage supply fails. This function is only possible with the “double-acting” operation mode and is carried out by a 5/2-way double solenoid pilot valve which remains in the position last occupied before the fault occurred when pressure is applied to one side of the actuator. If the compressed air supply fails, the valve cannot be guaranteed to remain in the current position.

Hold position with 5/3C pilot valve

The valve is held in the current position if the operating voltage supply or compressed air fails. This function is only possible with the “double-acting” operating mode and is carried out by a 5/3-way pilot valve with closed intermediate position.

Operating pressure

The operating pressure available for actuating the quarter turn actuator.

Note: A shorter delivery time can be offered for configurations with a single-acting mode of operation with an operating pressure of 3 bar or 6 bar.

Safety factor

The specification of a safety factor is recommended when configuring a quarter turn actuator because this increases the available torque reserve.

Pipeline medium liquid 1.35

Pipeline medium sticky/viscous 1.75

Pipeline medium gaseous 1.5

These values are reference values and must be reviewed according to the application.

Closing torque factor

Note: Specification of the closing torque factor is optional.

The torque required to operate the process valve is greatest at the start of the movement (breakaway torque). Under certain conditions, the closing torque of the process valve can be smaller than the breakaway torque. If this difference is known, it can be taken into account by specifying a closing torque factor.

Ambient temperature (minimum)

The ambient temperature refers to the immediate environment in which the quarter turn actuator is installed. When entering this parameter, take into account that the ambient temperature can be influenced by the temperature of the medium.

Ambient temperature (maximum)

The ambient temperature refers to the immediate environment in which the quarter turn actuator is installed. When entering this parameter, take into account that the ambient temperature can be influenced by the temperature of the medium.

Version

Standard

Standard corrosion resistance of the pneumatic quarter turn actuator. The actuator shaft is steel.

High corrosion protection

Higher corrosion resistance thanks to epoxy coating of the pneumatic quarter turn actuator. The actuator shaft is stainless steel.

Characteristics

Sensor principle, position indicator

This selection determines the measuring principle for the position indicator. Inductive sensors operate contactlessly. Magnetic reed and changeover switches operate with contacts.

Floating contact, changeover contact

Operating voltage range 0 ... 250 V AC

Operating voltage range 0 ... 30 V DC

Max. output current 3000 mA

Inductive

Operating voltage range 5 ... 60 V DC

Max. output current 100 mA

Magnetic reed

Operating voltage range 0 ... 120 V AC

Operating voltage range 0 ... 175 V DC

Max. output current 250 mA

Electrical output type, position indicator

By selecting the electrical output type, the output type of the position indicator is determined.

Datasheet

General technical data

Design	Rack and pinion
Mode of operation	Double-acting Single-acting
Size of valve actuator	10, 20, 40, 80, 120, 160, 240, 300, 480, 700, 900, 1,200, 2,300
Flange hole pattern	F03, F04, F05, F07, F10, F12, F14, F16
Swivel angle	90 deg
Product weight	1 ... 100 kg

Operating and ambient conditions

Ambient temperature	-50 ... 150°C
Operating pressure	0.2 ... 0.8 MPa
Operating pressure	29 ... 116 psi
Operating pressure	2 ... 8 bar
LABS (PWIS) conformity	VDMA24364 zone III
Note on materials	RoHS-compliant

ATEX VSNC

Short type code	VSNC
ATEX category gas	II 2G
Explosion ignition protection type for gas	Ex ia IIC T6 Ga
ATEX category dust	II 2D
Explosion ignition protection type for dust	Ex t IIIC T80°C Db
Explosion ambient temperature	-40°C ≤ Ta ≤ +50°C

ATEX SRBC

Short type code	SRBC
ATEX category gas	II 1G
Explosion ignition protection type for gas	Ex ia IIC T6...T1 Ga
ATEX category dust	II 1D
Explosion ignition protection type for dust	Ex i IIIC Txx°C Da
Explosion ambient temperature	See ATEX certificate, See IECEx certificate

ATEX SRBG

Short type code	SRBG
ATEX category gas	II 1G
Explosion ignition protection type for gas	Ex ia IIC T6...T1 Ga
ATEX category dust	II 1D
Explosion ignition protection type for dust	Ex ia IIIC T200 135°C Da
Explosion ambient temperature	See ATEX certificate, See IECEx certificate

Peripherals

Peripherals overview

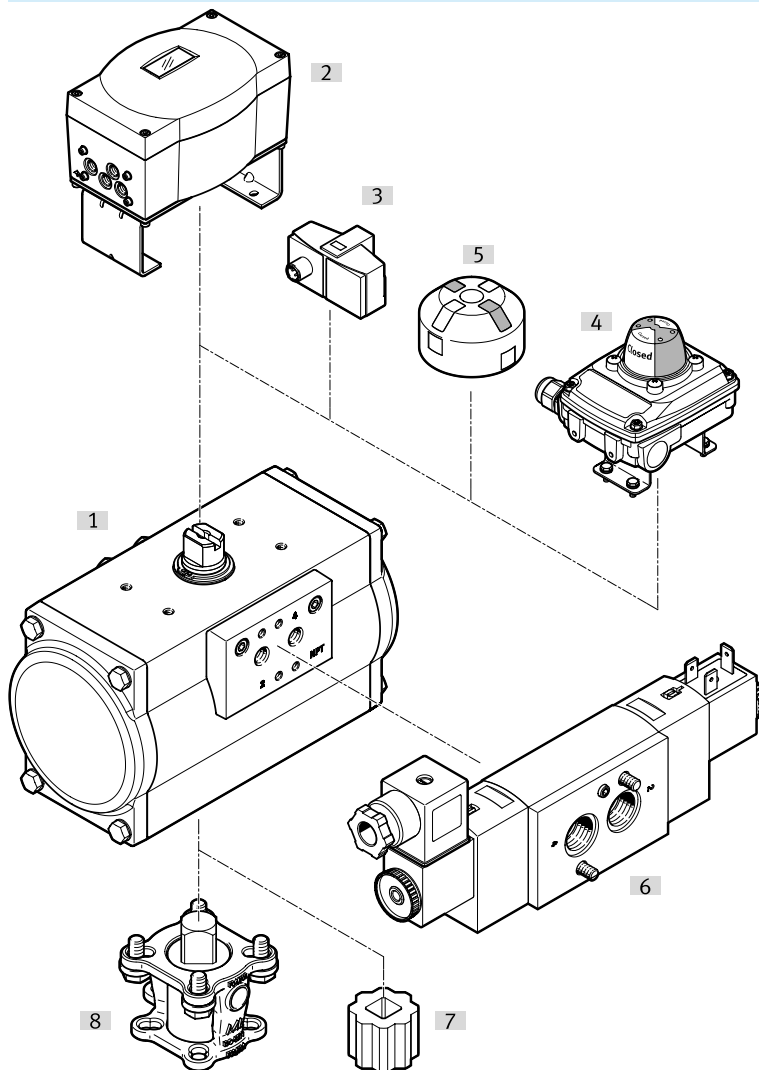

Accessories		→ Link
Type/order code	Description	
[1] Quarter turn actuators DFPD	In single-acting or double-acting design, has a gear rack-and-pinion combination with a constant torque curve over the entire swivel range, port pattern according to VDI/VDE 3845	dfpd
[2] Positioner CMSX	Based on the PID control algorithm, used for position control of single-acting and double-acting pneumatic quarter turn actuators with mechanical interface according to VDI/VDE 3845	cmsx
[3] Limit switch attachments SRBG	For electrical feedback and checking the position of process valves, is mounted without additional accessories on quarter turn actuators with port pattern according to VDI/VDE 3845, with M12 plug or terminal strip	srbg
[4] Limit switch attachments SRBC	For electrical feedback and control of the position of process valves, with mounting adapter, sturdy and corrosion-resistant design, highly visible 3D position indicator for quickly detecting the current position of the quarter turn actuator	srbc
[5] Position indicators SASF	The compact solution, the direct mounting really minimises the space requirement, with four fixed actuating vanes offset by 90°	sasf
[6] Solenoid valves VSNC	Pilot valves with solenoid coils VACF for single-acting and double-acting quarter turn actuators with port pattern according to VDI/VDE 3845, can be converted from 3/2 to 5/2 directional control valve simply by turning the seal	vsnc
[7] Reducing sleeves DARQ-R...	For square adjustment of the ball valves	darq
[8] Mounting kits DARQ-KV...	For connecting quarter turn actuators and ball valves	darq

Ordering data

Ordering information – Modular product system			
	Description	Part no.	Type
	Quarter turn actuator unit comprising quarter turn actuator DFPD and accessories, Select, size and order quickly, easily and reliably with the configurator, Optionally with pilot valve, positioner, position indicator and end position feedback, Optionally with the necessary mounting adapters or reducing sleeves for mounting on the process valve	8108611	KDFP-DFPD