

Angle gripper DHWS

FESTO

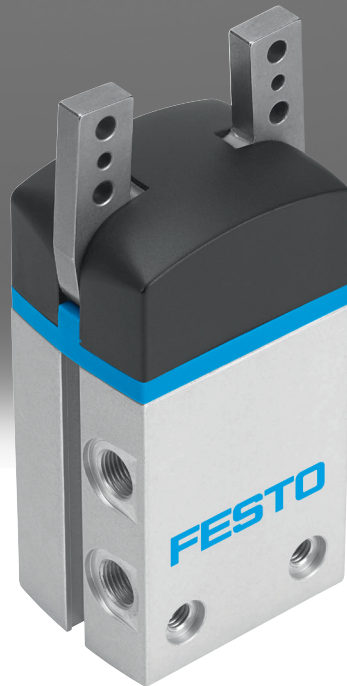

Characteristics

At a glance

[Further information → dhws](#)

General information:

- Improved gripper jaw guide
- Slotted guide
- Max. repetition accuracy
- Gripping force backup
- Internal fixed flow control
- Wide range of adaptation options on the drives

Sensors:

- Adaptable position sensor for small gripper sizes
- Integrated proximity switches for medium and large gripper sizes

Flexible range of applications:

- Can be used as a double-acting and single-acting gripper
- Compression spring for supporting or retaining the gripping forces
- Suitable for external and internal gripping

These grippers are not designed for the following or similar application examples:

- Machining
- Aggressive media
- Grinding dust
- Welding spatter

Engineering tools

[Further information → engineering tools](#)



Save time with engineering tools Smart Engineering for the optimal solution. Our goal is to increase your productivity. Our engineering tools play an integral part in this. They help you size your system correctly, tap into unimagined productivity reserves and generate additional productivity along the entire value chain. In every phase of your project, from the initial contact to the modernisation of your machine, you will come across a number of different tools which will be of use to you.

Gripper selection:

- This tool helps you to select the right grippers by simply entering the exact parameters for your application

Diagrams

[Further information → dhws](#)



The diagrams shown in this document are also available online. These can be used to display precise values.

Special material properties

Product:

Metals with more than 5% copper by mass are excluded from use. Exceptions are circuit boards, cables, electrical plug connectors and coils

Accessories:

Please contact your Festo representative for information on which accessories are suitable for manufacturing lithium-ion batteries

Position sensing

[A] For proximity sensor

By using proximity switches, any position can be detected.

Characteristics

Gripping force backup

[NC] N/O contact

Closed by spring force in depressurised state

Overview

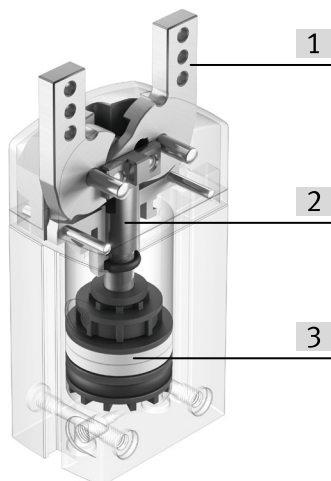

- [1] Gripper jaw
- [2] Link
- [3] Piston with magnet

Type code

001	Series	
DHWS	Angle gripper	

002	Size [mm]	
10	10	
16	16	
25	25	
32	32	
40	40	

003	Position sensing	
A	For proximity sensor	

004	Gripping force backup	
	None	
NC	N/O contact	

Datasheet

General technical data									
Size	10	16	25	32	40				
Design	Lever								
Mode of operation	Double-acting								
Gripping force backup	None	None N/O contact							
Gripper function	Angle								
Number of gripper jaws	2								
Max. opening angle	40 deg								
Pneumatic connection	M3			M5		G1/8			
Repetition accuracy, gripper ¹⁾	≤0.04 mm								
Max. replacement accuracy	≤0.2 mm								
Max. operating frequency of gripper	≤4 Hz				≤3 Hz				
Rotationally symmetrical	≤0.2 mm								
Position detection	Via Hall sensor			Via proximity switch					
Type of mounting	Either: Via female thread and centring sleeve Via through-hole and centring sleeve								
Mounting position	optional								

1) Under constant exposure to operating conditions, end-position drift occurs in the direction of movement of the gripper jaws, at 100 consecutive strokes

Operating and environmental conditions									
Size	10	16	25	32	40				
Operating medium	Compressed air to ISO 8573-1:2010 [7:4:4]								
Note on operating and pilot medium	Lubricated operation possible (in which case lubricated operation will always be required)								
Ambient temperature ¹⁾	5 ... 60°C								
Corrosion resistance class CRC ²⁾	1 - Low corrosion stress								

1) Note the operating range of the proximity switches

2) More information: www.festo.com/x/topic/crc

Operating pressure									
Size	10	16	25	32	40				
Gripping force backup	None	N/O contact	None	N/O contact	None	N/O contact	None	N/O contact	
Operating pressure	2 ... 8 bar		4 ... 8 bar		2 ... 8 bar		4 ... 8 bar		

Weight									
Size	10	16	25	32	40				
Gripping force backup	None	N/O contact	None	N/O contact	None	N/O contact	None	N/O contact	
Product weight	40 g	110 g	114 g	258 g	265 g	452 g	462 g	775 g	790 g

Materials	
Material housing	Wrought aluminium alloy, Hard anodised
Material gripper jaws	High-alloy steel
Material cover cap	PA
Note on materials	RoHS-compliant
LABS (PWIS) conformity	VDMA24364-B2-L
Suitability for the production of Li-ion batteries	Metals with more than 5% by mass of copper are excluded from use. Exceptions are printed circuit boards, cables, electrical plug connectors and coils

Datasheet

Gripping torque

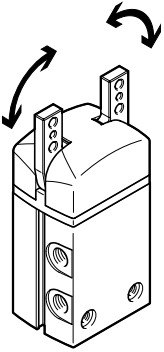

Size	10	16	25	32	40
Total gripping torque at 0.6 MPa (6 bar, 87 psi), opening	43 Ncm	129 Ncm	386 Ncm	810 Ncm	1,497 Ncm
Total gripper torque, closing, 0.6 MPa (6 bar, 87 psi)	30 Ncm	114 Ncm	356 Ncm	746 Ncm	1,362 Ncm

Characteristic load values at the gripper jaws

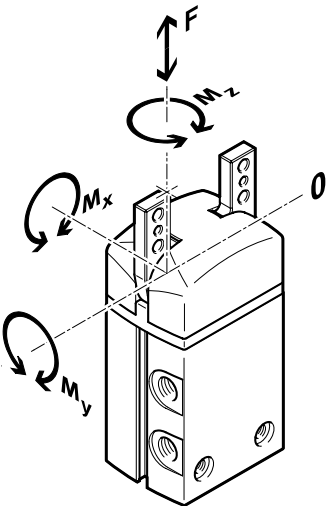

The indicated permissible forces and torques apply to a single gripper jaw. They include the lever arm, additional applied loads created by the workpiece or external gripper fingers and acceleration forces occurring during movement. The zero coordinate line (gripper jaw guide) must be taken into account when calculating torques.

Size	10	16	25	32	40
Max. force on gripper jaw F_z static	25 N	50 N	90 N	120 N	200 N
Max. torque at gripper M_x static	0.6 Nm	1.6 Nm	3.6 Nm	6 Nm	13 Nm
Max. torque at gripper M_y static	0.6 Nm	1.6 Nm	3.6 Nm	6 Nm	13 Nm
Max. torque at gripper M_z static	0.6 Nm	1.6 Nm	3.6 Nm	6 Nm	13 Nm

Datasheet

Gripping force FH per gripper jaw as a function of operating pressure and lever arm x

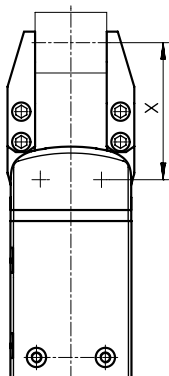

The gripping forces as a function of operating pressure and lever arm can be determined from the following graphs.
The gripping torque is not constant across the opening angle.

Sizing software for gripper selection → <https://www.festo.com/x/topic/eng>

Gripping force FH per gripper jaw as a function of operating pressure and lever arm x – external gripping (closing), double-acting – DHWS-10

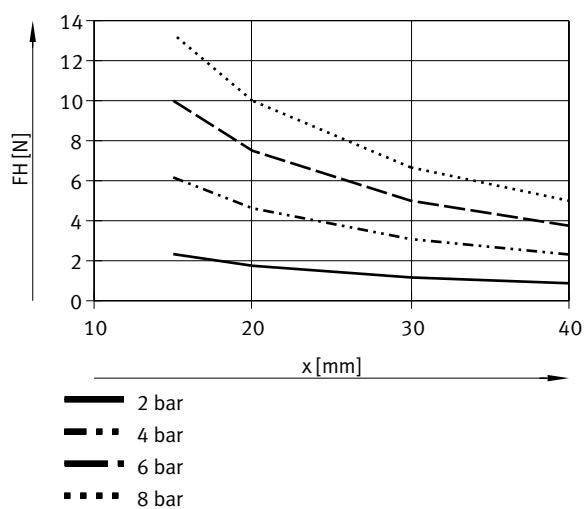

Gripping force FH per gripper jaw as a function of operating pressure and lever arm x – external gripping (closing), double-acting – DHWS-16

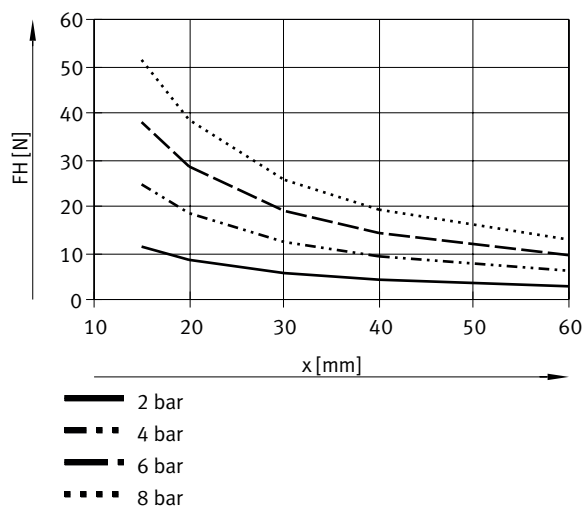

Datasheet

Gripping force FH per gripper jaw as a function of operating pressure and lever arm x – external gripping (closing), double-acting – DHWS-25

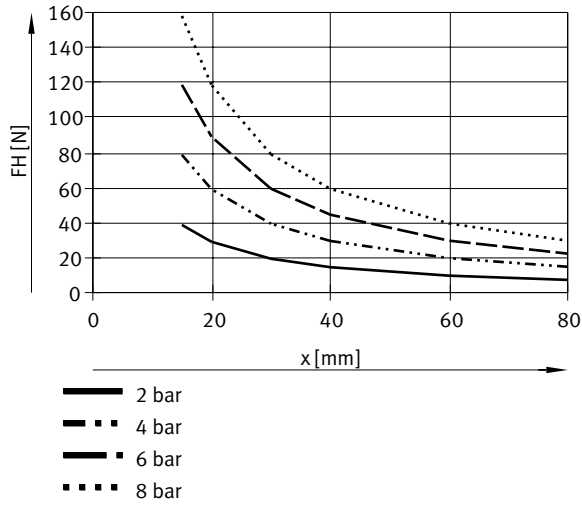

Gripping force FH per gripper jaw as a function of operating pressure and lever arm x – external gripping (closing), double-acting – DHWS-32

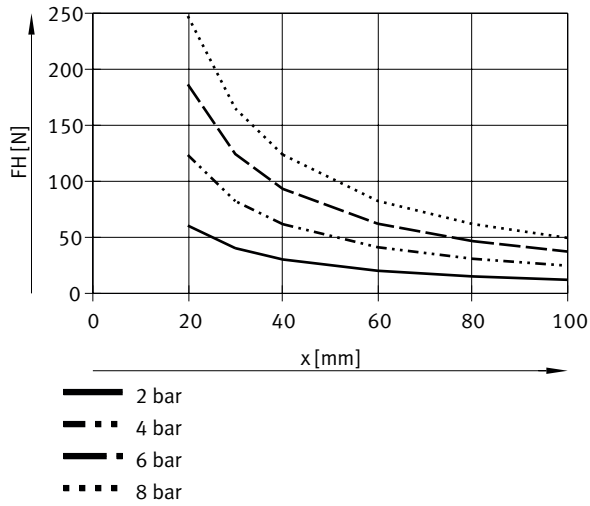

Datasheet

Gripping force FH per gripper jaw as a function of operating pressure and lever arm x – external gripping (closing), double-acting – DHWS-40

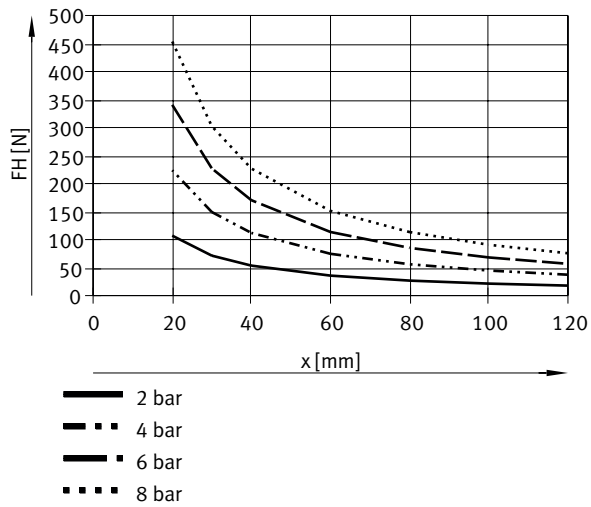

Gripping force FH per gripper jaw as a function of operating pressure and lever arm x – internal gripping (opening), double-acting – DHWS-10

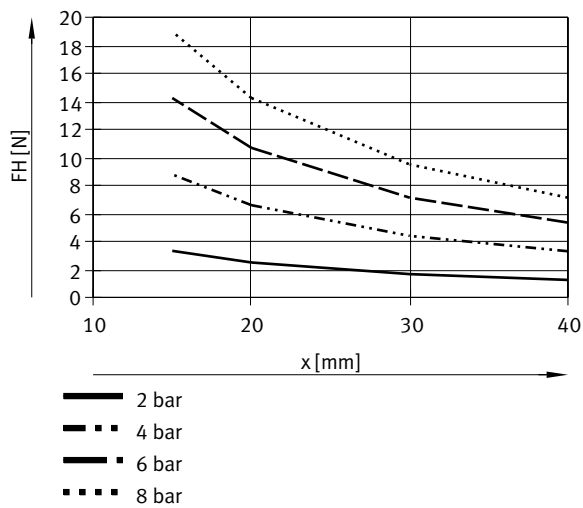

Datasheet

Gripping force FH per gripper jaw as a function of operating pressure and lever arm x – internal gripping (opening), double-acting – DHWS-16

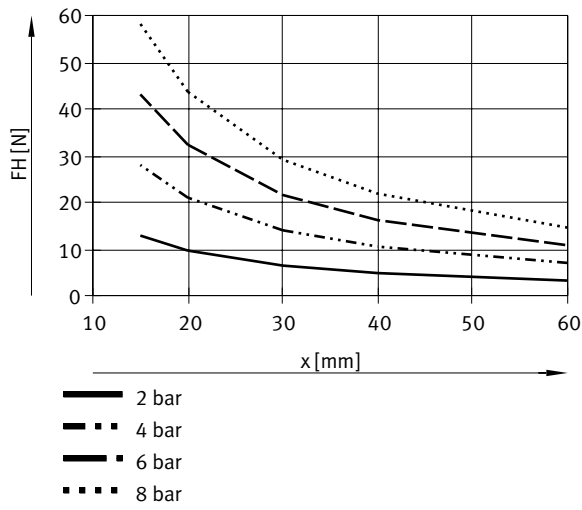

Gripping force FH per gripper jaw as a function of operating pressure and lever arm x – internal gripping (opening), double-acting – DHWS-25

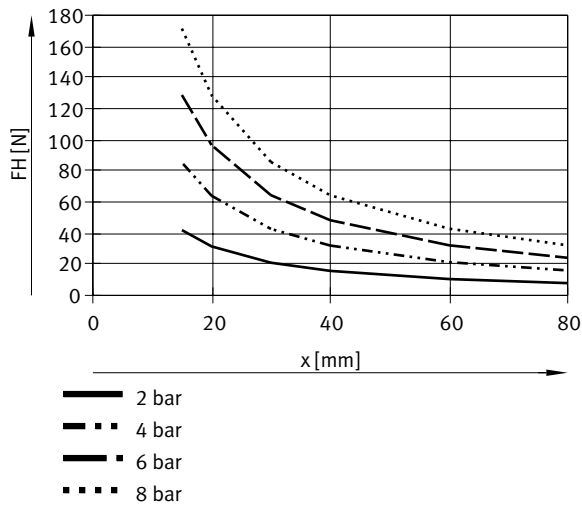

Datasheet

Gripping force FH per gripper jaw as a function of operating pressure and lever arm x – internal gripping (opening), double-acting – DHWS-32

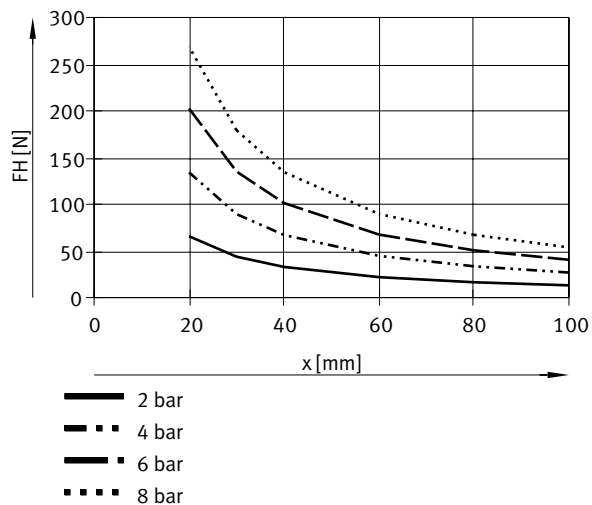

Gripping force FH per gripper jaw as a function of operating pressure and lever arm x – internal gripping (opening), double-acting – DHWS-40

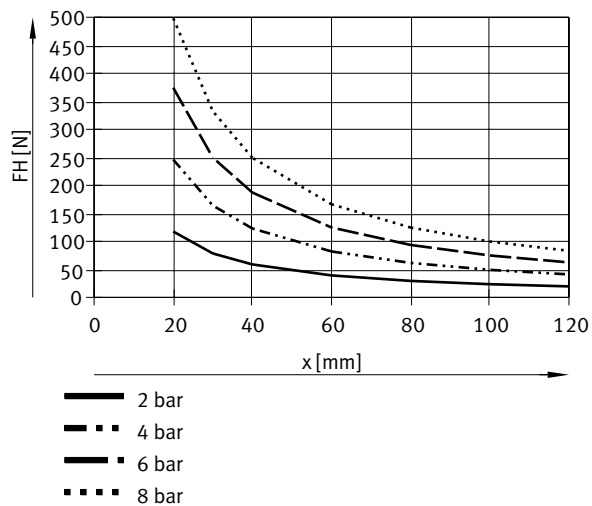

Datasheet

Gripping force FH per gripper jaw at 0.6 MPa (6 bar, 87 psi) as a function of lever arm x and eccentricity a and b

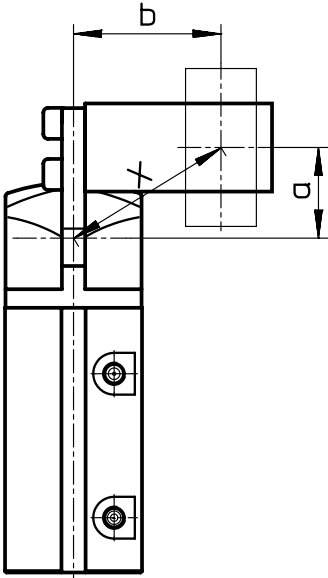

Gripping force FH per gripper jaw at 0.6 MPa (6 bar, 87 psi) as a function of lever arm x and eccentricity a and b

$$x = \sqrt{a^2 + b^2} = \sqrt{20^2 + 25^2} = 32 \text{ mm}$$

The formula (on the left) must be used to calculate the lever arm x with eccentric gripping.
The gripping force FH can then be read from the graphs using the calculated value x.

Calculation example:

Where:

Distance a = 20 mm

Distance b = 25 mm

To be determined:

The gripping force at 6 bar with a DHWS-16, used as an external gripper.

Gripping force FH per gripper jaw at 0.6 MPa (6 bar, 87 psi) as a function of lever arm x and eccentricity a and b

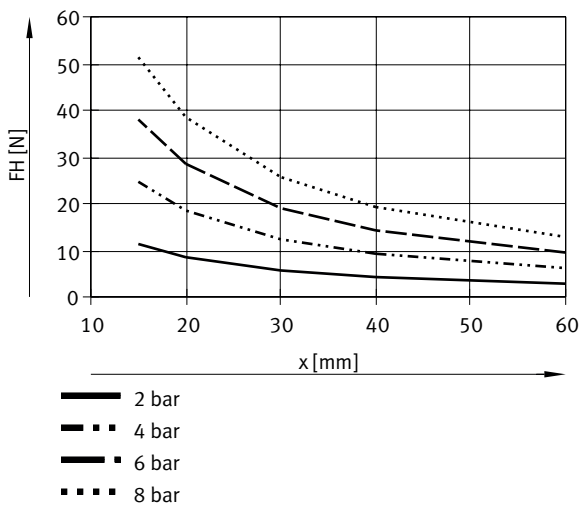

The graph gives a value of FH = 18 N for the gripping force.

Datasheet

Spring torque MF as a function of the opening angle

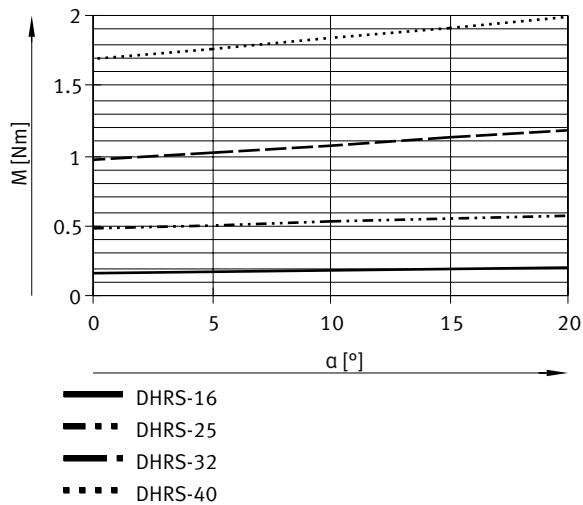

Determining the actual gripping torques MGrtotal for DHWS-...-NC as a function of the application

Depending on the requirement, the angle grippers with integrated spring, type DHWS-...-NC (closing gripping force backup) can be used as:

- Single-acting grippers
- Gripper with gripping force support and
- Grippers with gripping force backup

To calculate the available gripping torque MGrtotal (per gripper jaw), the gripping force FH and the spring torque MF must be combined accordingly.

$$MGr = FH \cdot x$$

MGr = Gripping torque

FH = Gripping force

x = Lever arm

Determining the actual gripping torques MGrtotal for DHWS-...-NC as a function of the application – application

Single-acting:

- Gripping with spring force: $MGr_{total} = MF$
- Gripping with pressure force: $MGr_{total} = MGr - MF$

Gripping force support:

- Gripping with pressure and spring force: $MGr_{total} = MGr + MF$

Gripping force retention

- Gripping with spring force: $MGr_{total} = MF$

Datasheet

Mass moments of inertia

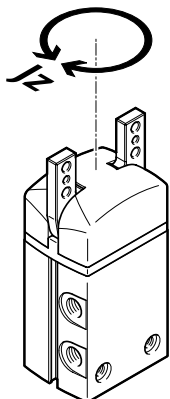

Mass moment of inertia of the gripper in relation to the central axis, without external gripper fingers, with no load.

Size	10	16	25	32	40				
Gripping force backup	None		N/O contact	None		N/O contact	None		N/O contact
Mass moment of inertia	0.03 kgcm ²	0.14 kgcm ²	0.15 kgcm ²	0.62 kgcm ²	0.64 kgcm ²	1.6 kgcm ²	1.63 kgcm ²	3.81 kgcm ²	3.87 kgcm ²

Opening and closing times

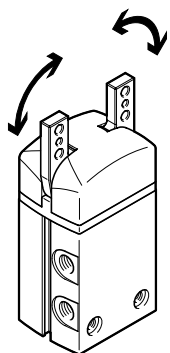

The indicated opening and closing times [ms] were measured at room temperature, 0.6 MPa (6 bar, 87 psi) operating pressure and with the gripper installed horizontally without additional gripper fingers. The grippers must be throttled for higher masses [g]. Opening and closing times must then be adjusted accordingly.

Size	10	16	25	32	40				
Gripping force backup	None		N/O contact	None		N/O contact	None		N/O contact
Min. opening time at 0.6 MPa (6 bar, 87 psi)	10 ms	44 ms	62 ms	64 ms	106 ms	46 ms	88 ms	63 ms	99 ms
Min. closing time at 0.6 MPa (6 bar, 87 psi)	22 ms	52 ms	36 ms	80 ms	59 ms	77 ms	55 ms	96 ms	69 ms

Opening and closing times t to be set as a function of mass moment of inertia of the gripper fingers with 0.6 MPa (6 bar, 87 psi) – DHWS-10

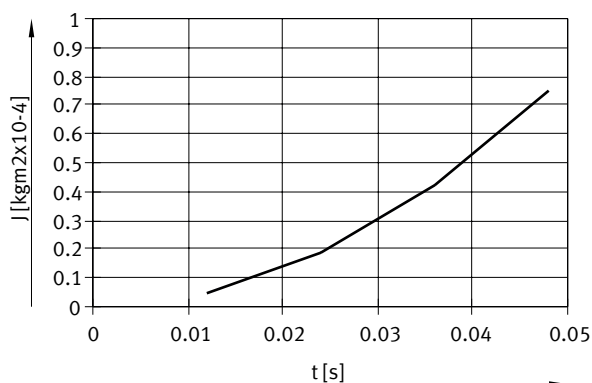

Datasheet

Opening and closing times T to be set as a function of mass moment of inertia of the gripper fingers with 0.6 MPa (6 bar, 87 psi) – DHWS-16

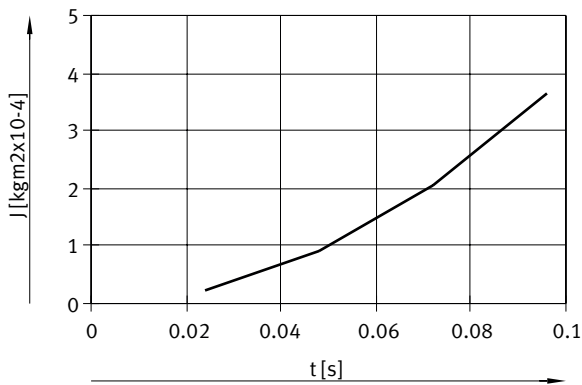

Opening and closing times T to be set as a function of mass moment of inertia of the gripper fingers with 0.6 MPa (6 bar, 87 psi) – DHWS-25

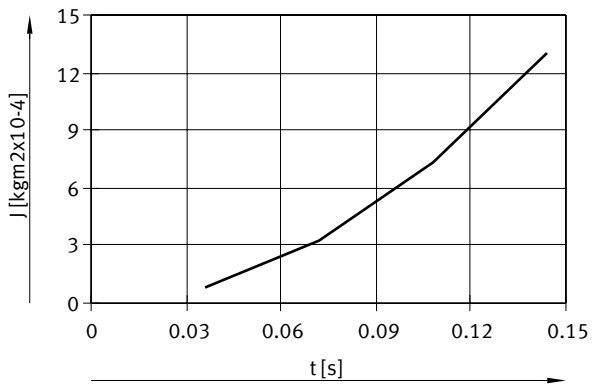

Opening and closing times T to be set as a function of mass moment of inertia of the gripper fingers with 0.6 MPa (6 bar, 87 psi) – DHWS-32

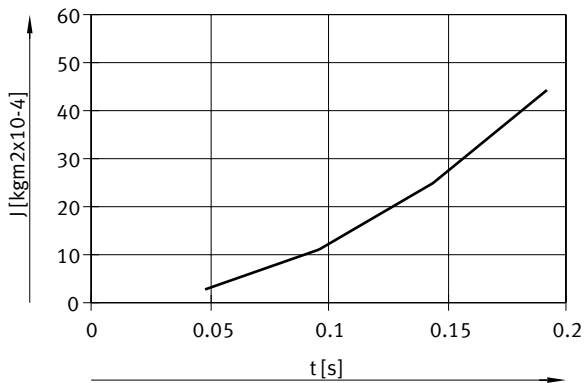

Datasheet

Opening and closing times T to be set as a function of mass moment of inertia of the gripper fingers with 0.6 MPa (6 bar, 87 psi) – DHWS-40

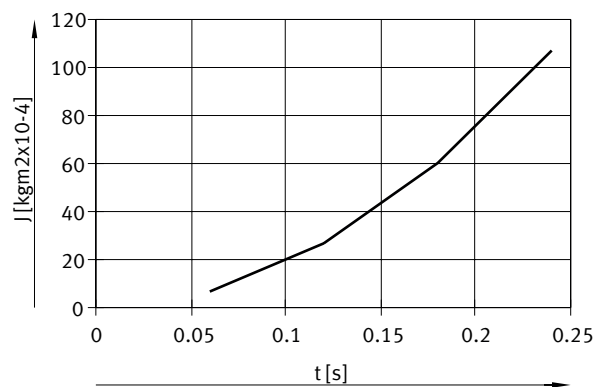

Dimensions

Dimensions – Angle gripper DHWS

Download CAD data → www.festo.com

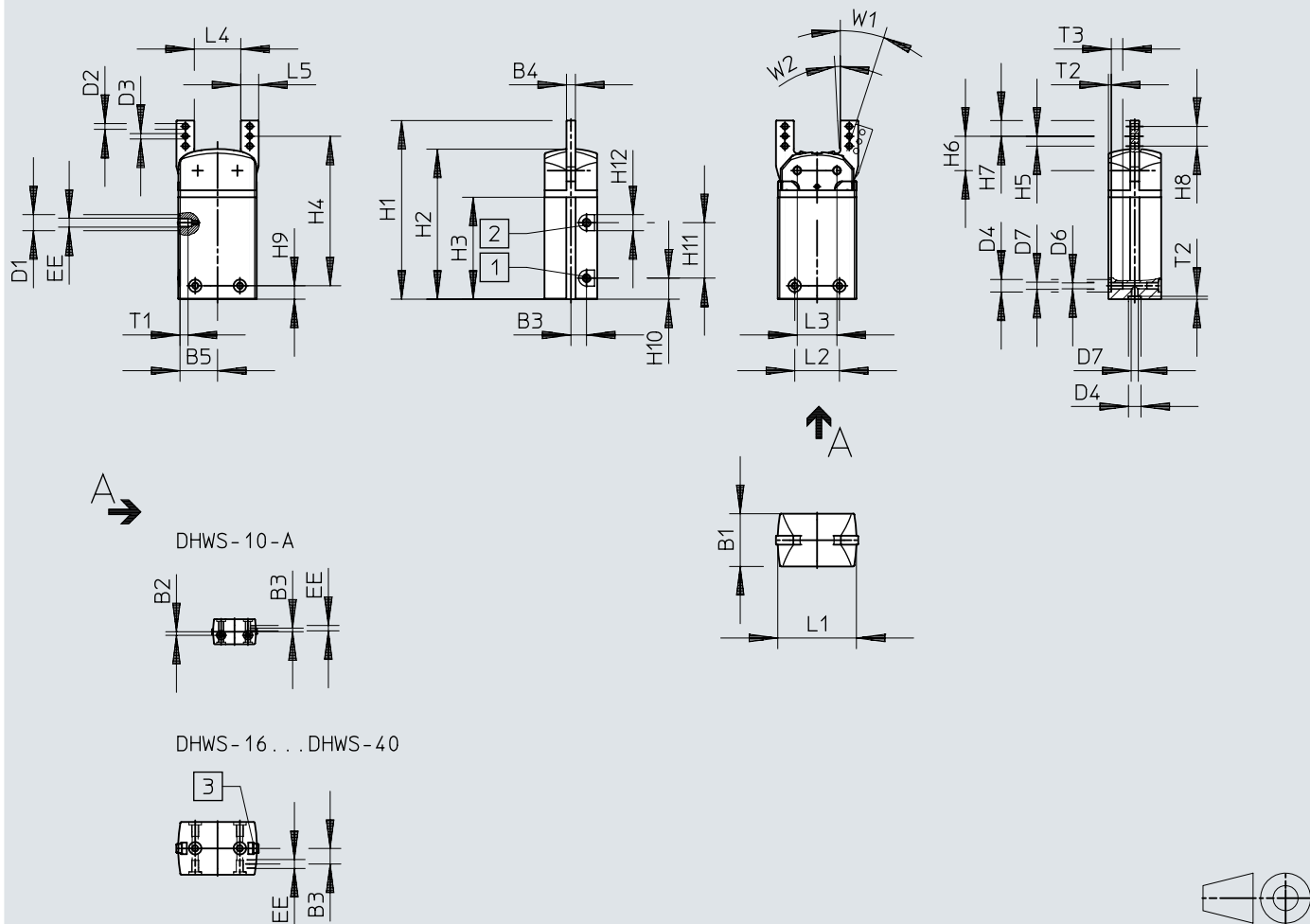

- [1] Open compressed air supply port
- [2] Close compressed air supply port
- [3] Slot for proximity switch

Dimensions

	B1 ±0,05	B2 ¹⁾	B3	B4 -0,03/ -0,05	B5	D1 ∅	D2 ∅ ±0,1	D3 ∅ H8	D4 ∅ H8/h7	D6 ∅ +0,1	D7
DHWS-10	14	2	2	3	11,6	7	2,2	2	5	2,4	M3
DHWS-16	19	-	5,8	4	16	-	3,2	2,5	5	2,5	M3
DHWS-25	29,5	-	8,75	5	21	9	3,2	3	7	3,3	M4
DHWS-32	38	-	11	6	24	15	4,3	3	9	5,1	M6
DHWS-40	49	-	11	8	28,4	15	5,3	4	12	6,4	M8

	EE	H1	H2	H3	H4 ±0,2	H5	H6 ±0,05	H7	H8	H9 ²⁾	H10
DHWS-10	M3	56,3	46	30,8	38,25	3,5	10,95	5,75	7	12,3	8,8
DHWS-16	M3	81	67	45,5	66	4,5	15,5	7,5	9	7,5	12,25
DHWS-25	M5	100	84	57	83,7	5,5	19,2	8,8	11	7,5	11,8
DHWS-32	G1/8	116	96,2	65	100,5	6,5	22,5	11	13	11	20
DHWS-40	G1/8	129	108,4	71,5	99,5	7	24,5	12	14	17,5	9

	H11	H12	L1 ±0,05	L2 ¹⁾	L3 ±0,02	L4	L5 -0,02/ -0,05	T1 +0,5	T2 +0,1	T3 +1	W1 +3°/-1°	W2 ±1°
DHWS-10	16	7	24	15	12,4	14	5,5	3,5	1,2	-	18	3
DHWS-16	23	7	34	16	17	18	8	4,5	1,2	5,8	18	3
DHWS-25	31	9	44	25	22,2	26	10	4,5	1,6	6,4	18	3
DHWS-32	25	15	53	29	25,8	29	12	7,5	2,1	12,9	18	3
DHWS-40	46	15	59	33	30	32	15	6	2,6	13,4	18	3

1) Tolerance for centring hole ±0.02 mm Tolerance for thread ±0.1 mm

2) Tolerance for centring hole -0.05 mm/tolerance for thread ±0.1 mm

Dimensions

Dimensions – Angle gripper DHWS – mounting interface

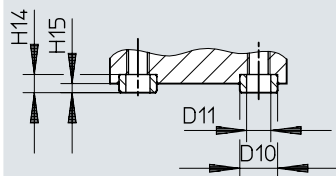
Download CAD data → www.festo.com

[1] Centring sleeves ZBH for mounting the gripper (2 pieces included in the scope of delivery)

	D10 ∅ h7	D11 ∅	H14 -0,2	H15 -0,3
DHWS-10	5	3,2	2,4	1,2
DHWS-16	5	3,2	2,4	1,2
DHWS-25	7	5,3	3	1,4
DHWS-32	9	6,4	4	1,9
DHWS-40	12	10,3	5	2,4

Ordering data

Double-acting, without compression spring				
	Size	Product weight	Part no.	Type
	10	40 g	1310177	DHWS-10-A
	16	110 g	1310178	DHWS-16-A
	25	258 g	1310180	DHWS-25-A
	32	452 g	1310182	DHWS-32-A
	40	775 g	1310184	DHWS-40-A

Single-acting or with gripping force backup, closing				
	Size	Product weight	Part no.	Type
	16	114 g	1310179	DHWS-16-A-NC
	25	265 g	1310181	DHWS-25-A-NC
	32	462 g	1310183	DHWS-32-A-NC
	40	790 g	1310185	DHWS-40-A-NC

Peripherals

Peripherals overview DHWS-10

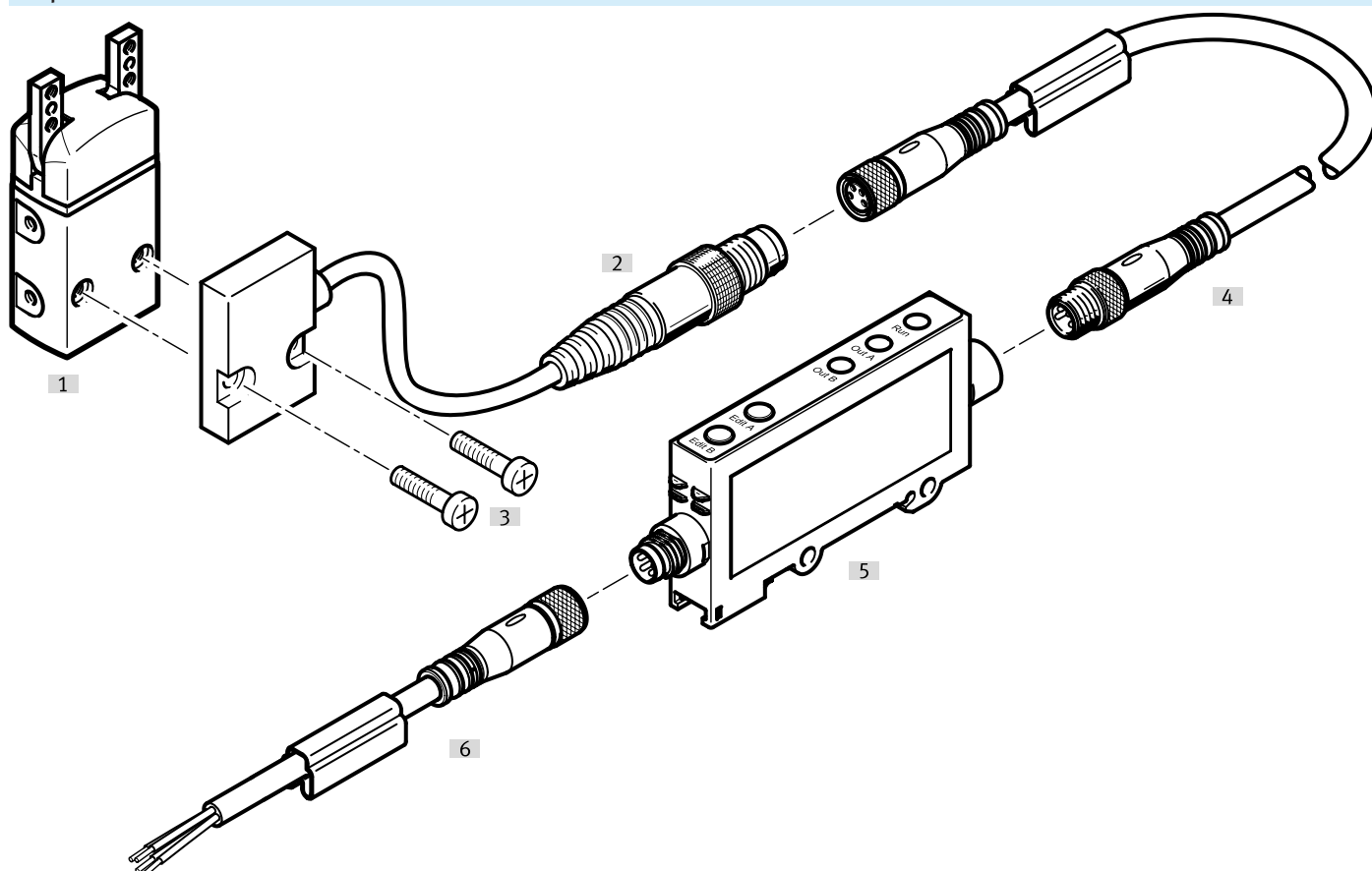

Accessories			→ Link
Type/order code	Description		
[1] Angle gripper DHWS	Double-acting		dhws
[2] Position sensor SMH-S1	Adaptable and integrable sensors for sensing the piston position		24
[3] Screws	For mounting the SMH-S1 position sensor on the gripper		dhws
[4] Connecting cable NEBU	Connection between position sensor and signal converter		24
[5] Signal converter SVE4	For signal evaluation for position sensor SMH-S1		24
[6] Connecting cable NEBU	Connection between signal converter and controller		26
[7] Adapter kit DHAA, HMSV, HAPG	Connecting plate between drive and gripper		dhaa
[8] Proportional-pressure regulator VPPM	For infinitely variable adjustment of the gripping force		vppm

Peripherals

Peripherals overview DHWS-16 ... 40

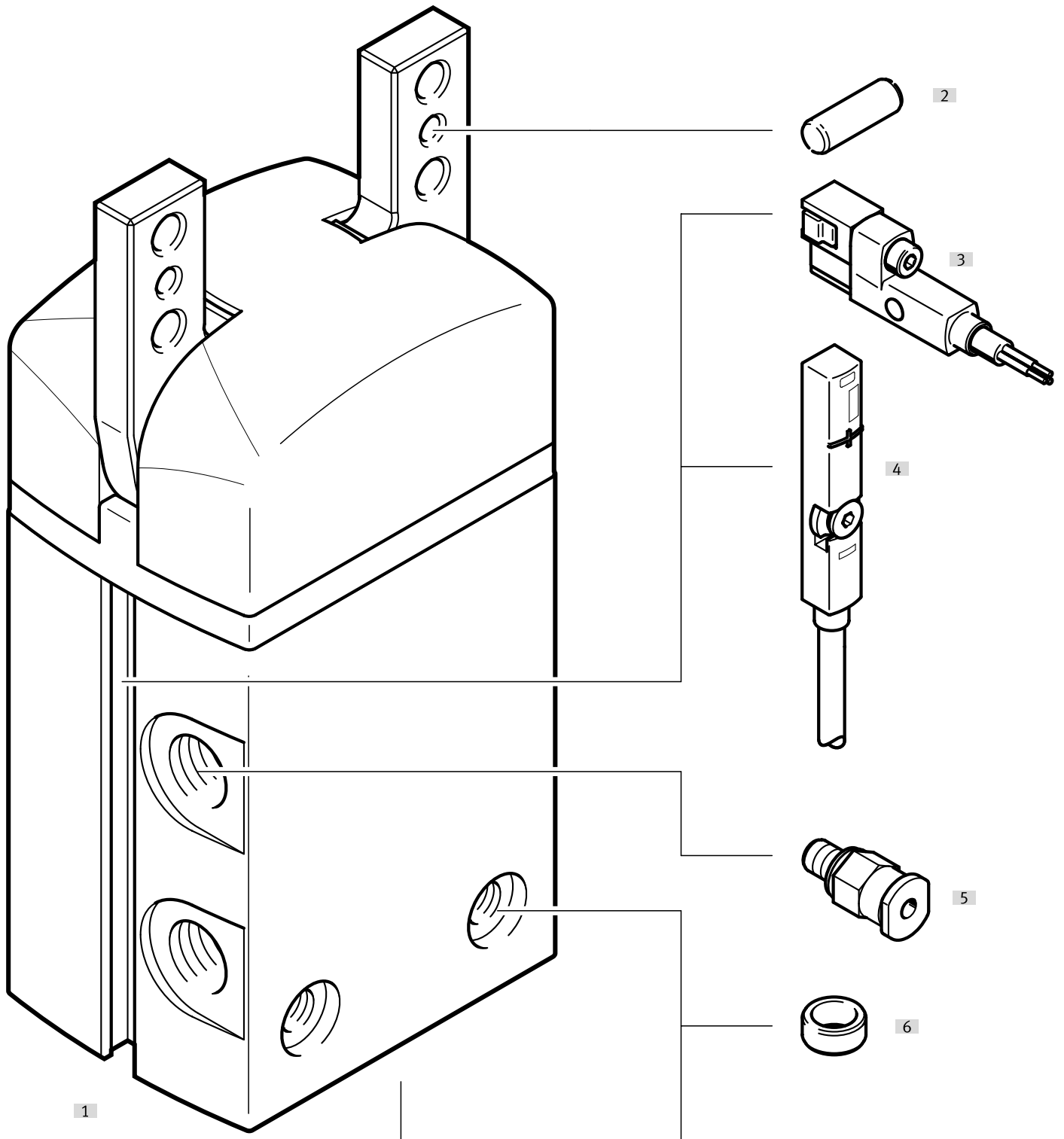

Accessories			→ Link
Type/order code	Description		
[1] Angle gripper DHWS	Double-acting		dhws
[2] Centring pin	For centring the gripper fingers on the gripper jaws		dhws
[3] Proximity switch SMT-8G	- To sense the piston position - Proximity switch does not protrude underneath the housing		25
[4] Position transmitter SMAT-8M	Continuously senses the position of the piston. It has an analogue output with an output signal in proportion to the piston position		26

Peripherals

Accessories		→ Link
Type/order code	Description	
[4] Position transmitter SDAT	Continuously senses the position of the piston. It has an analogue output with an output signal in proportion to the piston position	26
[5] Push-in fitting QS	For connecting tubing with standard O.D.	qs
[6] Centring sleeve ZBH	- For centring the gripper during mounting - 2 centring sleeves are included in the scope of delivery of the gripper	24
[7] Adapter kit DHAA, HMSV, HAPG	Connecting plate between drive and gripper	dhaa
[8] Proportional-pressure regulator VPPM	For infinitely variable adjustment of the gripping force	vppm

Accessories

Centring sleeve ZBH-5

	Description	Material sleeve	Size of pack	Product weight	Part no.	Type
	For sizes 10, 16	Steel	10	1 g	8146543	ZBH-5-B

Centring sleeve ZBH-7

	Description	Material sleeve	Size of pack	Product weight	Part no.	Type
	For size 25	Steel	10	1 g	8146544	ZBH-7-B

Centring sleeve ZBH-9

	Description	Material sleeve	Size of pack	Product weight	Part no.	Type
	For size 32	Steel	10	2 g	8137184	ZBH-9-B

Centring sleeve ZBH-12

	Description	Material sleeve	Size of pack	Product weight	Part no.	Type
	For size 40	Steel	10	1 g	8137185	ZBH-12-B

Position sensor SMH-S1 for direct fastening, magnetic Hall – for size 10

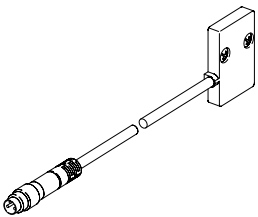
	Type of mounting ¹⁾	Output signal	Electrical connection	Cable length	Part no.	Type
	Screwed to gripper	Analogue	Plug M8, A-coded	0.5 m	175711	SMH-S1-HGW10

1) Installation note: To ensure the functionality of the position sensor, the cable outlet and the outlet of the compressed air tube must point in the same direction during installation.

Signal converter SVE4 – for size 10

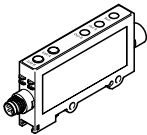
	analog input	Electrical connection (signal input)	Electrical connection (switching output)	Switching output	Part no.	Type
	Adapted for position sensors SMH-S1-HG	Socket M8x1, 4-pin	Plug M8x1, 4-pin	2xNPN	544219	SVE4-HS-R-HM8-2N-M8
				2xPNP	544216	SVE4-HS-R-HM8-2P-M8

Connecting cables NEBU, straight – connection between position sensor and signal converter

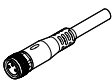
	Electrical connection 1, connector system	Electrical connection 2, connector system	Electrical connection 2, number of connections/cores	Cable length	Part no.	Type
	M8x1, A-coded, to EN 61076-2-104	M8x1, A-coded to EN 61076-2-104	4	2.5 m	554035	NEBU-M8G4-K-2.5-M8G4

Accessories

Connecting cables NEBU, straight – connection between signal converter and controller

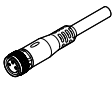
	Electrical connection 1, connector system	Electrical connection 2, connector system	Electrical connection 2, number of connections/ cores	Cable length	Part no.	Type
	M8x1, A-coded, to EN 61076-2-104	Open end	4	2.5 m	541342	NEBU-M8G4-K-2.5-LE4
				5 m	541343	NEBU-M8G4-K-5-LE4

Connecting cables NEBU, angled – connection between signal converter and controller

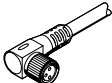
	Electrical connection 1, connector system	Electrical connection 2, connector system	Electrical connection 2, number of connections/ cores	Cable length	Part no.	Type
	M8x1, A-coded, to EN 61076-2-104	Open end	4	2.5 m	541344	NEBU-M8W4-K-2.5-LE4
				5 m	541345	NEBU-M8W4-K-5-LE4

Proximity switch SMT-8G for T-slot, magneto-resistive – for sizes 16 ... 40

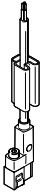
	Type of mounting	Switching output	Electrical connection	Cable length	Part no.	Type
	Clamped in T-slot, Insertable in the slot lengthwise	3-wire NPN N/O contact	Open end	2.5 m	8065028	SMT-8G-NS-24V-E-2,5Q-OE
			Plug M8, A-coded	0.3 m	8065027	SMT-8G-NS-24V-E-0,3Q-M8D
		3-wire PNP N/O contact	Open end	2.5 m	547859	SMT-8G-PS-24V-E-2,5Q-OE
			Plug M8, A-coded	0.3 m	547860	SMT-8G-PS-24V-E-0,3Q-M8D

Connecting cable NEBU, straight

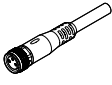
	Electrical connection 1, connector system	Electrical connection 2, connector system	Electrical connection 2, number of connections/ cores	Cable length	Part no.	Type
	M8x1, A-coded, to EN 61076-2-104	Open end	3	2.5 m	541333	NEBU-M8G3-K-2.5-LE3
				5 m	541334	NEBU-M8G3-K-5-LE3

Connecting cable NEBU, angled

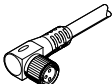
	Electrical connection 1, connector system	Electrical connection 2, connector system	Electrical connection 2, number of connections/ cores	Cable length	Part no.	Type
	M8x1, A-coded, to EN 61076-2-104	Open end	3	2.5 m	541338	NEBU-M8W3-K-2.5-LE3
				5 m	541341	NEBU-M8W3-K-5-LE3

Accessories

Position transmitter SMAT-8M for T-slot, plug M8, A-coded – for size 16 ... 40

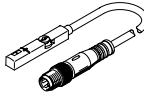
	Sensing range	Analogue output	Electrical connection 1, number of connections/ cores	Cable length	Part no.	Type
	52 mm	0 - 10 V	4	0.3 m	553744	SMAT-8M-U-E-0,3-M8D

Position transmitter SDAT for T-slot, M8 plug, A-coded – for size 32 ... 40

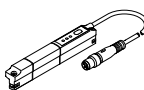
	Sensing range	Analogue output	Electrical connection 1, number of connections/ cores	Cable length	Part no.	Type
	0 ... 50.000 mm	4 - 20 mA	4	0.3 m	1531265	SDAT-MHS-M50-1L-SA-E-0.3-M8

Connecting cables NEBU, straight

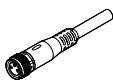
	Electrical connection 1, connector system	Electrical connection 2, connector system	Electrical connection 2, number of connections/ cores	Cable length	Part no.	Type
	M8x1, A-coded, to EN 61076-2-104	Open end	4	2.5 m	541342	NEBU-M8G4-K-2.5-LE4
				5 m	541343	NEBU-M8G4-K-5-LE4

Connecting cables NEBU, angled

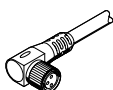
	Electrical connection 1, connector system	Electrical connection 2, connector system	Electrical connection 2, number of connections/ cores	Cable length	Part no.	Type
	M8x1, A-coded, to EN 61076-2-104	Open end	4	2.5 m	541344	NEBU-M8W4-K-2.5-LE4
				5 m	541345	NEBU-M8W4-K-5-LE4