

Linear drives DGPL

FESTO

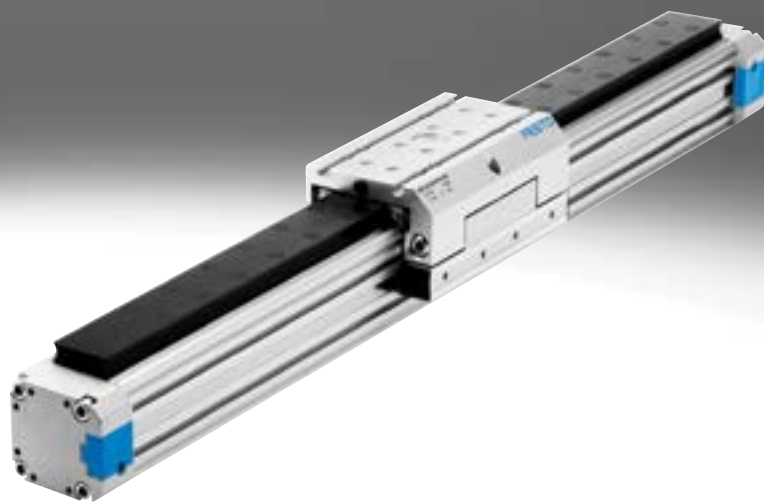

Key features

General

- Compact, installation length relative to stroke
- Very flexible thanks to wide choice of mounting and attachment options
- Adjustable end-position cushioning systems
- Can be combined with the modular system for handling and assembly technology
- Maintenance-free (for up to 5000 km with a recirculating ball bearing guide)
- Wide choice of variants:
 - Extended slide
 - Air connections on both sides
 - Electronic cushioning with Softstop SPC11

With recirculating ball bearing guide DGPL-KF-GK/-GV

- Piston \varnothing 18 ... 80 mm
- Stroke lengths from 10 ... 3000 mm
- Backlash-free
- DGPL-GK: standard slide
DGPL-GV: extended slide
- Precise and rigid guide
- For high loads and torques

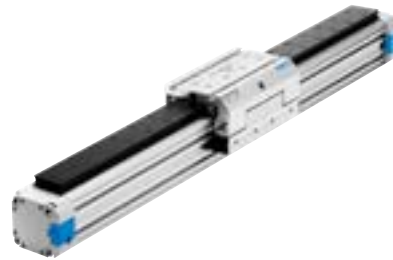

Protected version DGPL-GA

- Piston \varnothing 18 ... 40 mm
- Stroke lengths from 10 ... 2000 mm
- Guide and slide are fitted with a cover to protect against the ingress of particles from above and from the side
- Backlash-free
- Precise and rigid guide
- For high loads and torques



Key features

Guide characteristics

The specifications for forces and torques are based on the variant with standard slide (GK).
The values for the other variants can be found in the relevant catalogue data sheet.

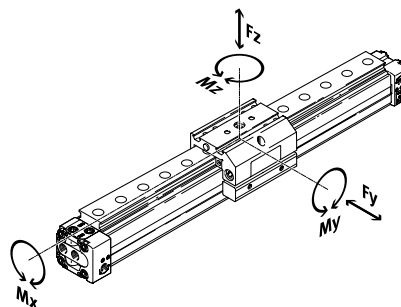

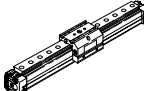
Design	Piston \varnothing [mm]	Stroke [mm]	Theoretical force at 6 bar [N]	Forces and torques					→ Page/Internet
				Fy [N]	Fz [N]	Mx [Nm]	My [Nm]	Mz [Nm]	
With recirculating ball bearing guide DGPL-KF									
	18	10 ... 1800	153	930	930	7	23	23	5
	25	10 ... 3000	295	3080	3080	45	85	85	
	32	10 ... 3000	483	3080	3080	63	127	127	
	40	10 ... 3000	754	7300	7300	170	330	330	
	50	10 ... 3000	1178	7300	7300	240	460	460	
	63	10 ... 3000	1870	14050	14050	580	910	910	
	80	10 ... 3000 ¹⁾	3016	14050	14050	745	1545	1545	

1) Piston \varnothing 80: For usable strokes longer than 2000 mm, the drive must be mounted with the sealing band facing downwards; longer strokes on request.

Note

Piston \varnothing 8 and 12: linear drives DGC → Internet: dgc
 Alternatives to DGPL...-GF: linear drives DGC...-GF → Internet: dgc
 Alternatives to DGP: linear drives DGC-K → Internet: dgc

Key features

System product for handling and assembly technology

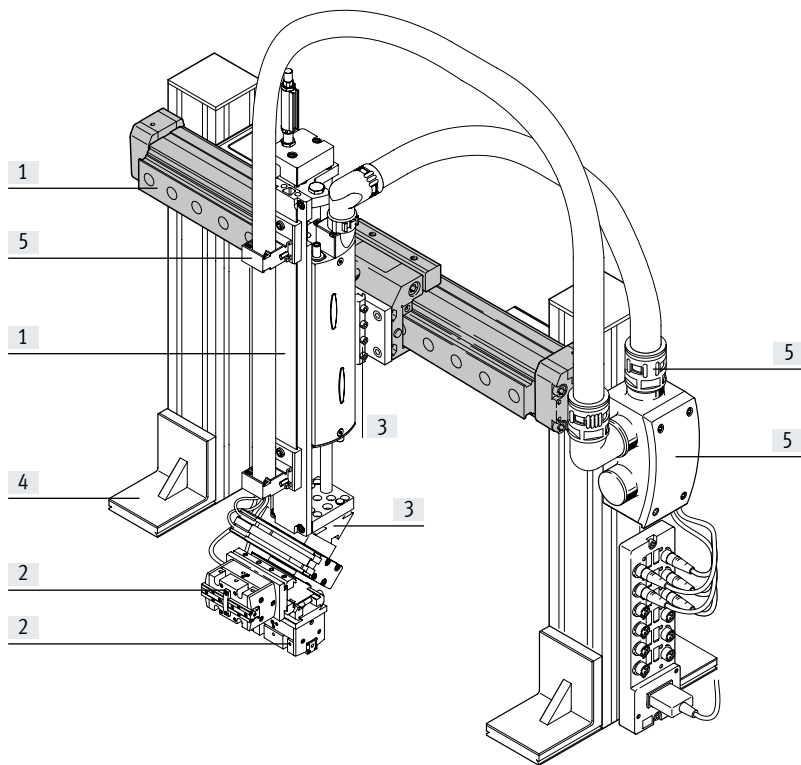

System components and accessories

	Description	→ Page/Internet
[1] Drives	Wide range of combinations possible within handling and assembly technology	drive
[2] Grippers	Wide range of variations possible within handling and assembly technology	gripper
[3] Adapters	For drive/drive connections	28
	For drive/gripper connections	gripper
[4] Basic components	Profiles and profile connections as well as profile/drive connections	basic component
[5] Installation components	For a clear, safe layout of electrical cables and tubing	installation component
– Axes	Wide range of combinations possible within handling and assembly technology	axis
– Motors	Servo and stepper motors, with or without gearbox	motor

Peripherals overview

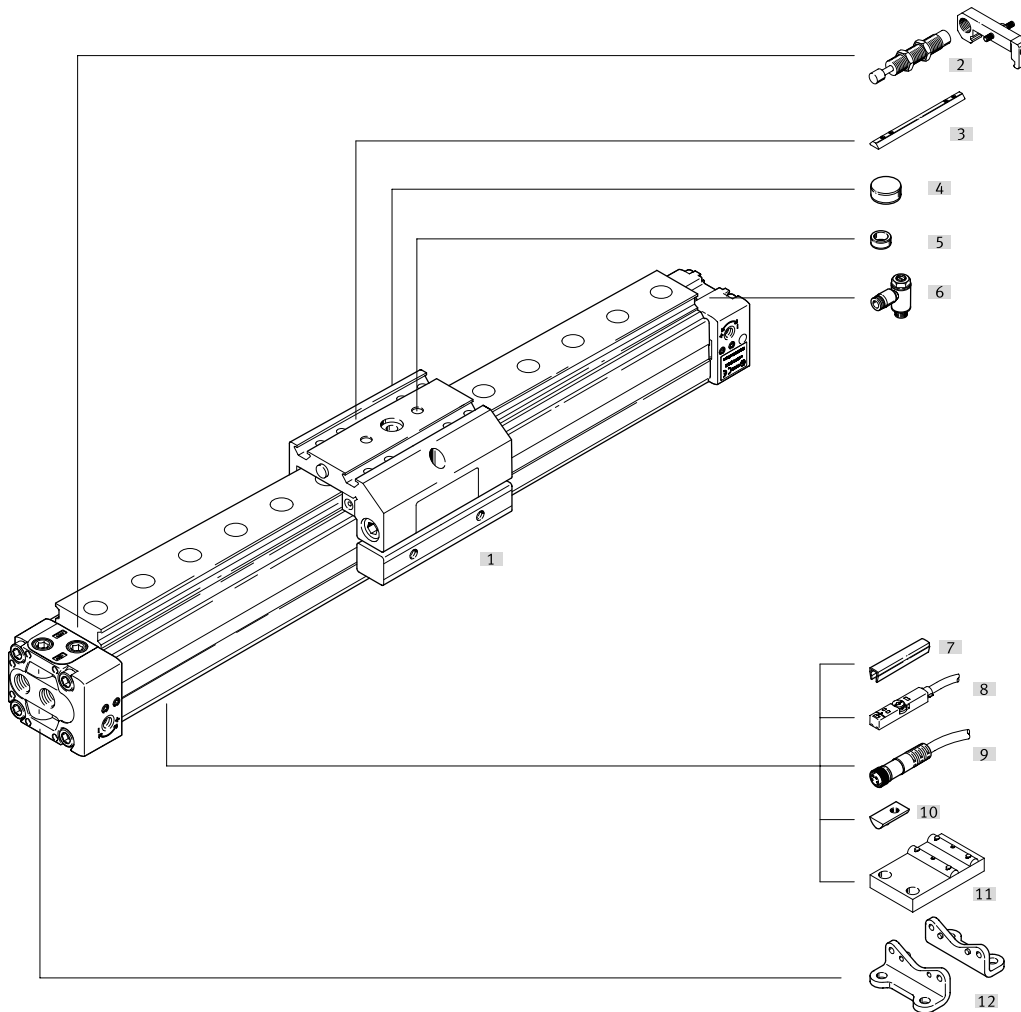

Variants and accessories		Description	DGPL		→ Page/Internet
Type/order code			KF	GA	
[1]	Linear axis DGPL	Pneumatic linear drive with slide	■	■	6
[2]	Shock absorber kit C	Higher speeds can be decelerated using shock absorbers	■	–	24
	Shock absorber kit E	Higher speeds can be decelerated using shock absorbers	–	■	25
[3]	Slot nut for slide X	For mounting loads and attachments on the slide	■	■	26
[4]	Central mounting Q	For centring loads and attachments on the slide	■	■	26
[5]	Centring pins/sleeves Z	For centring loads and attachments on the slide	■	■	26
[6]	One-way flow control valve GRLA	For regulating speed	■	■	25
[7]	Slot cover B/S	For protecting against contamination and securing the proximity switch cable	■	■	26
[8]	Proximity switch G/H/I/J/N	For sensing the slide position	■	■	27
[9]	Connecting cable V	Via proximity switch	■	■	27
[10]	Slot nut for profile barrel Y	For mounting attachments	■	■	26
[11]	Central support M	For mounting the axis	■	■	23
[12]	Foot mounting F	For mounting the axis	■	■	22

Type codes

001	Series	
DGPL	Linear drive with slide	
002	Piston diameter	
18	18	
25	25	
32	32	
40	40	
50	50	
63	63	
80	80	
003	Stroke	
...	10 ... 3000	
004	Cushioning	
PPV	Pneumatic cushioning, adjustable at both ends	
005	Position sensing	
A	For proximity sensor	
006	Generation	
B	Function-optimised	
007	Guide	
KF	Recirculating ball bearing guide	
008	Basic version	
GK	Piston/slide standard	
GV	Extended piston/slide	
009	Slide attachment position	
SH	Slide at rear	
SV	Slide at front	
010	Compressed air connection	
D2	Both sides	
011	Protection	
GA	Protected version	
012	Accessories	
ZUB-	Accessories supplied loose	
013	Slot cover, sensor slot	
...S	1 ... 10 pieces	

014	Slot cover for mounting slot	
...B	1...10 pieces	
015	Slot nut for slides	
... X	1 ... 10 units	
016	Slot nut, mounting slot	
...Y	1 ... 10 pieces	
017	Centring sleeves	
... Z	10 ... 90 units	
018	Central support	
...M	1 ... 10 pieces	
019	Central mounting	
... Q	1 ... 10 units	
020	Foot mounting [unit]	
... F	1 - 10 units	
021	Proximity sensor, cable 2.5 m	
...G	1 ... 10 pieces	
022	Proximity sensor, plug M8	
...H	1 ... 10 pieces	
023	Proximity sensor, contactless, cable 2.5 m	
...I	1 ... 10 pieces	
024	Proximity sensor, contactless, plug M8	
...J	1 ... 10 pieces	
025	Proximity sensor, N/C contact, cable 2.5 m	
...N	1 ... 10 pieces	
026	Connecting cable 2.5 m, plug M8	
...V	1 ... 10 pieces	
027	Shock absorber, self-adjusting, with retaining bracket	
... C	1 ... 10 units	
028	Shock absorber [unit]	
... E	1 - 10 units	

Data sheet

Function

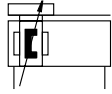

www.festo.com

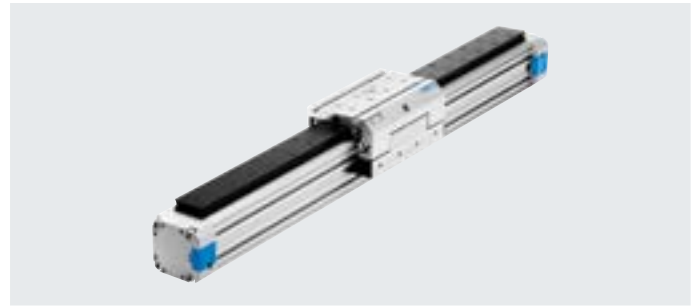

- Size
18 ... 80 mm
- Stroke
1 ... 3000 mm

General technical data

Piston Ø	18	25	32	40	50	63	80
Design	Pneumatic linear drive with slide						
Guide	Recirculating ball bearing guide						
Mode of operation	Double-acting						
Driver principle	Positive-locking (slot)						
Mounting position	Any						
Pneumatic connection	M5	G1/8		G1/4		G3/8	G1/2
Stroke length [mm]	10 ... 1800		10 ... 3000 ¹⁾				
Cushioning	Adjustable at both ends Self-adjusting at both ends						
Cushioning length (PPV) [mm]	16	18	20	30			83
Position sensing	Via proximity switch						
Max. speed							
DGPL-KF [m/s]	3						
DGPL-GA [m/s]	3						

1) Piston Ø 80: For usable strokes longer than 2000 mm, the drive must be mounted with the sealing band facing downwards; longer strokes on request.

Operating and environmental conditions

Piston Ø	18	25	32	40	50	63	80
Operating medium	Compressed air to ISO 8573-1:2010 [7:-:-]						
Note on the operating/pilot medium	Lubricated operation possible (in which case lubricated operation will always be required)						
Operating pressure [bar]	2 ... 8			1.5 ... 8			
Ambient temperature ¹⁾ [°C]	-10 ... +60						
ATEX	Selected types → www.festo.com						

1) Note operating range of proximity switches.

Forces [N] and impact energy [Nm]

Piston Ø	18	25	32	40	50	63	80
Theoretical force at 6 bar	153	295	483	754	1178	1870	3016
Impact energy	→ Page 9						

Weight [kg]

Piston Ø	18	25	32	40	50	63	80
Basic weight with 0 mm stroke	0.83	1.52	2.72	4.48	9.6	15.37	28.7
Additional weight per 10 mm stroke	0.026	0.053	0.069	0.097	0.167	0.236	0.270
Moving mass	0.29	0.43	0.58	1.15	1.96	3.22	7.50

Materials

Piston Ø	18	25	32	40	50	63	80
Slide	Anodised aluminium						
Sealing band/cover strip	Polyurethane/steel						
Cover	Painted aluminium						
Cylinder barrel	Anodised aluminium						
Piston seal	Polyurethane						
Slide elements	Polyacetal						
Note on materials	RoHS-compliant						

Data sheet

Characteristic load values for axis with recirculating ball bearing guide KF or protected version GA

The indicated forces and torques refer to the centre of the guide rail. These values must not be exceeded during dynamic operation. Special attention must be paid to the deceleration phase.

If the drive is simultaneously subjected to several of the indicated forces and torques, the following equation must be satisfied in addition to the indicated maximum loads:

$$\frac{F_y}{F_{y_{max.}}} + \frac{F_z}{F_{z_{max.}}} + \frac{M_x}{M_{x_{max.}}} + \frac{M_y}{M_{y_{max.}}} + \frac{M_z}{M_{z_{max.}}} \leq 1$$

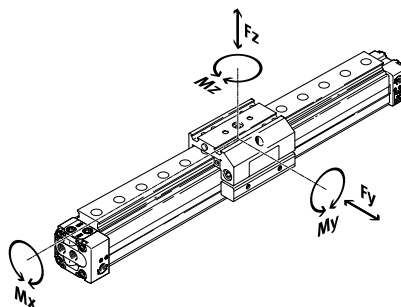

Permissible forces and torques								
Piston ø		18	25	32	40	50	63	80
DGPL-GK/-GA (standard slide, protected)								
F _y _{max.}	[N]	930	3080	3080	7300	7300	14050	14050
F _z _{max.}	[N]	930	3080	3080	7300	7300	14050	14050
M _x _{max.}	[Nm]	7	45	63	170	240	580	745
M _y _{max.}	[Nm]	23	85	127	330	460	910	1545
M _z _{max.}	[Nm]	23	85	127	330	460	910	1545
DGPL-GV (extended slide)								
F _y _{max.}	[N]	930	3080	3080	7300	7300	14050	–
F _z _{max.}	[N]	930	3080	3080	7300	7300	14050	–
M _x _{max.}	[Nm]	7	45	63	170	240	580	–
M _y _{max.}	[Nm]	45	170	250	660	920	1820	–
M _z _{max.}	[Nm]	45	170	250	660	920	1820	–

Data sheet

Operating range of the integrated end-position cushioning PPV

Maximum permissible speed v as a function of the moving mass M

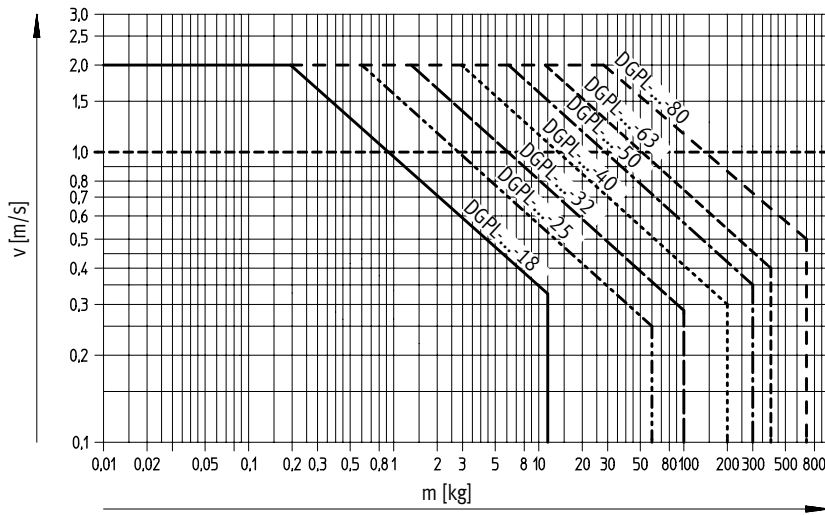

Note
 The specifications apply to a horizontal mounting position, applied load on top.
 m = applied load + moving mass
 → page 7
 The adjacent graph refers to r_{max} .

Pneumatic linear drives

with slide DGPL

The end-position cushioning must be adjusted to ensure jerk-free operation. If the operating conditions are outside the permissible range, the load to be moved must be externally cushioned using suitable equipment (shock absorbers, stops, etc), preferably at the centre of gravity of the load.

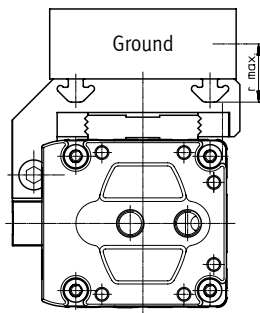

$r_{max} = 20$ mm
 for piston $\varnothing 18$ mm

$r_{max} = 50$ mm
 for piston $\varnothing 25 \dots 80$ mm
 (specifications for larger load distances on request)

Note
 Evenness of applied loads for pneumatic linear drives with slide DGPL: to prevent the guide elements from tightening or slackening, the support surface for the assembly must maintain an evenness of 0.03 mm.

Max. permissible support spacing l depending on the force F

The axis may need to be supported with central supports MUP in order to limit deflection in the case of long strokes. The following graphs can be used to determine the maximum permissible support span l as a function of force F acting on the axis.

Force on the surface of the slide

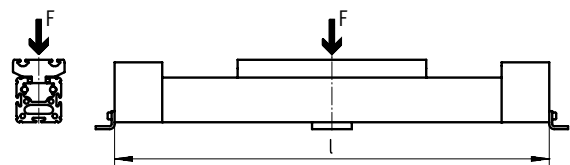
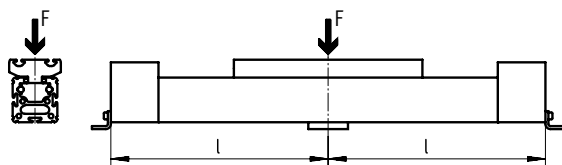

Piston $\varnothing 18 \dots 40$

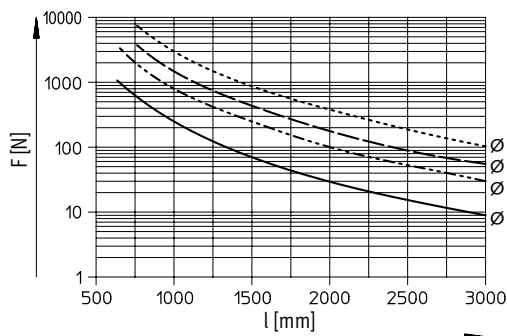

Piston $\varnothing 50 \dots 80$

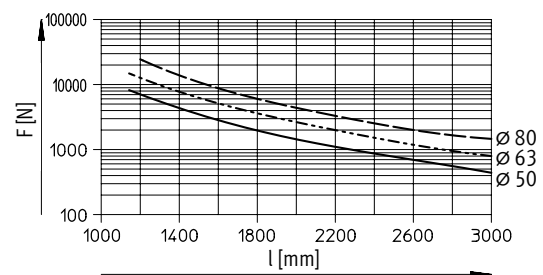

Data sheet

Dimensions

Download CAD data → www.festo.com

Standard slide GK

Piston Ø 18

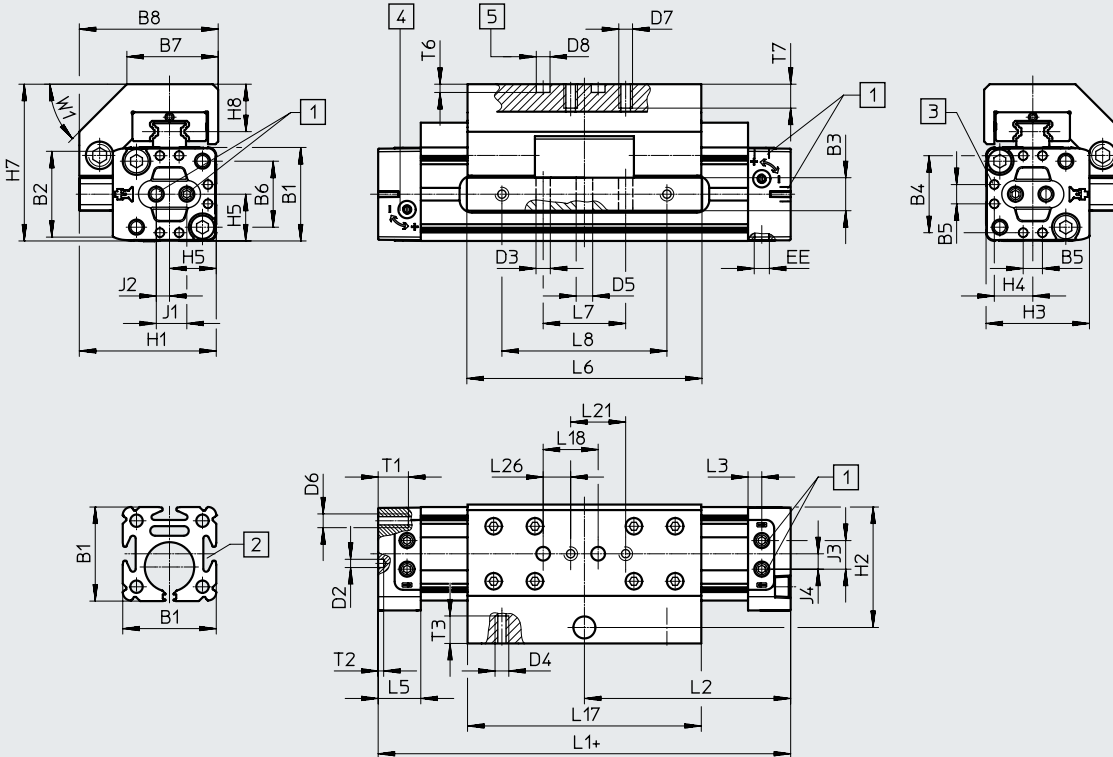

- [1] DGPL-...:
Compressed air supply ports on one end cap, optionally on 3 sides
DGPL-...-D2:
Compressed air supply ports at both ends, optionally on 3 sides
 - [2] Sensor slot for proximity switch
 - [3] Centring hole for foot mounting HP-...
 - [4] Adjusting screw for adjustable end-position cushioning
 - [5] Drilled hole for centring pin ZBS-5
- + = plus stroke length

Extended slide GV

Piston Ø 18

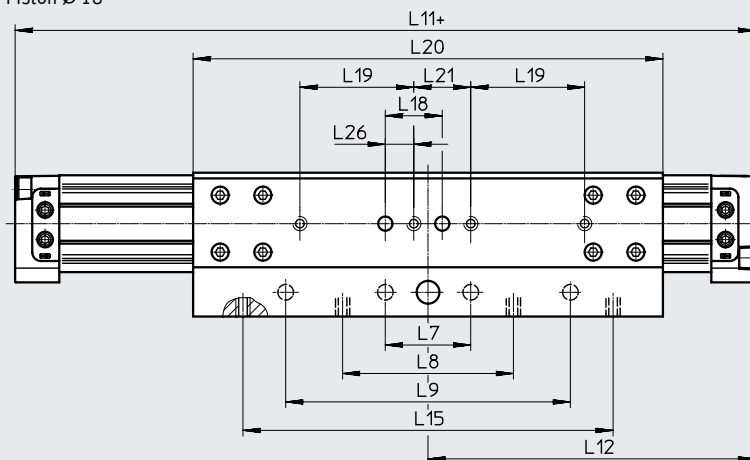

Data sheet

Dimensions

Download CAD data → www.festo.com

Protected version GA

Piston \varnothing 18

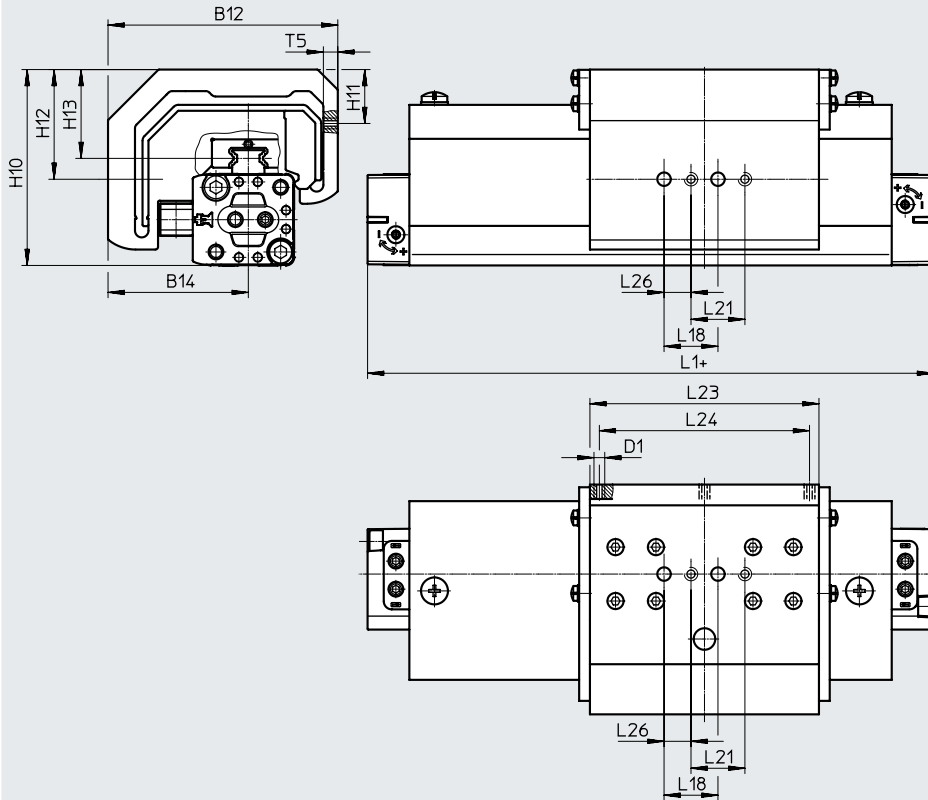

\varnothing	B1	B2	B3	B4	B5	B6	B7	B8	B12	B14	D1	D2	
[mm]			± 0.1									\varnothing	
18	34	31.2	12	28	7	24	32	50.5	85.25	52.05	M4	3	
\varnothing	D3	D4	D5	D6	D7	D8	EE	H1	H2	H3	H4	H5	
[mm]	\varnothing $+0.2$		\varnothing H7			\varnothing H7							
18	5.2	M5	6	M5	M5	5	M5	49.8	43.8	37.6	14	17	
\varnothing	H7	H8	H10	H11	H12	H13	J1	J2	J3	J4	L1	L2	
[mm]													
18	57	17	72.7	20	40.7	32.8	11.1	4.8	10.4	5.6	150	75	
\varnothing	L3	L5	L6	L7	L8	L9	L11	L12	L15	L17	L18		
[mm]				± 0.1	± 0.1	± 0.1	$+0.9/-0.2$	$+0.3/-0.6$	± 0.1	± 1	± 0.03		
18	5	15.5	85	30	60	100	230	115	130	85	20		
\varnothing	L19	L20	L21	L23	L24	L26	T1	T2	T3	T5	T6	T7	W1
[mm]	± 0.03		± 0.1			± 0.1					$+0.2$	max.	
18	40	165	20	85	78	10	11	2	10	5.35	3	10	45°

Data sheet

Dimensions

Download CAD data → www.festo.com

Standard slide GK

Piston \varnothing 25

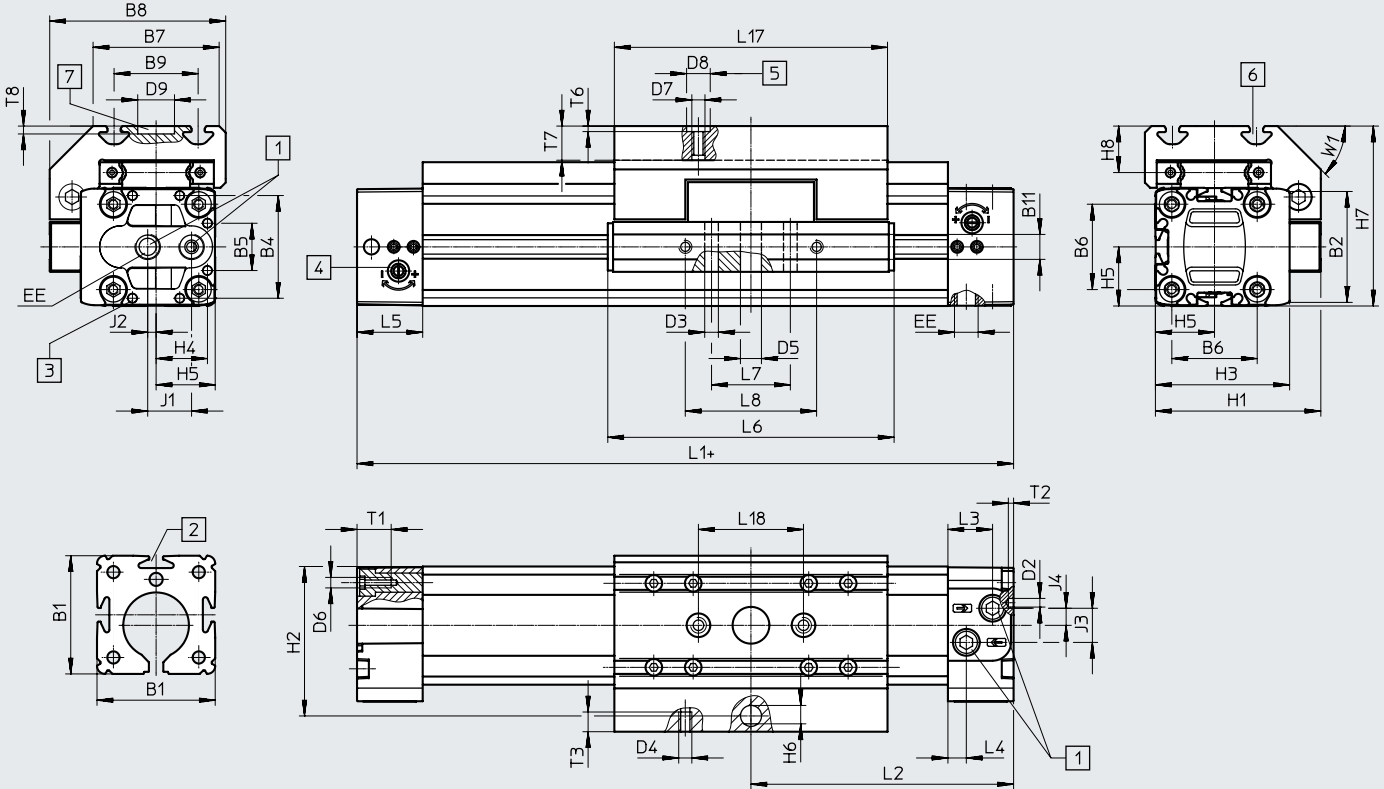

- | | | | | | | | |
|---|--------------------------------------|--|--|--|--|--|------------------------|
| [1] DGPL-...:
Compressed air supply ports on one end cap, optionally on 3 sides
DGPL-...-D2:
Compressed air supply ports at both ends, optionally on 3 sides | [2] Sensor slot for proximity switch | [3] Centring hole for foot mounting HP-... | [4] Adjusting screw for adjustable end-position cushioning | [5] Drilled hole for centring sleeve ZBH-9 | [6] Mounting slot for slot nut NSTL-25 | [7] Drilled hole for central mounting SLZZ | + = plus stroke length |
|---|--------------------------------------|--|--|--|--|--|------------------------|

Extended slide GV

Piston \varnothing 25

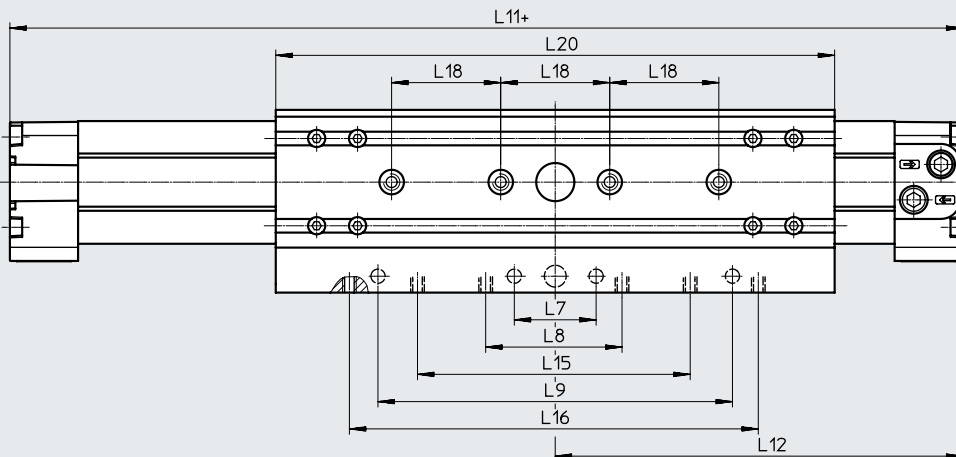

Data sheet

Dimensions

Download CAD data → www.festo.com

Protected version GA

Piston \varnothing 25

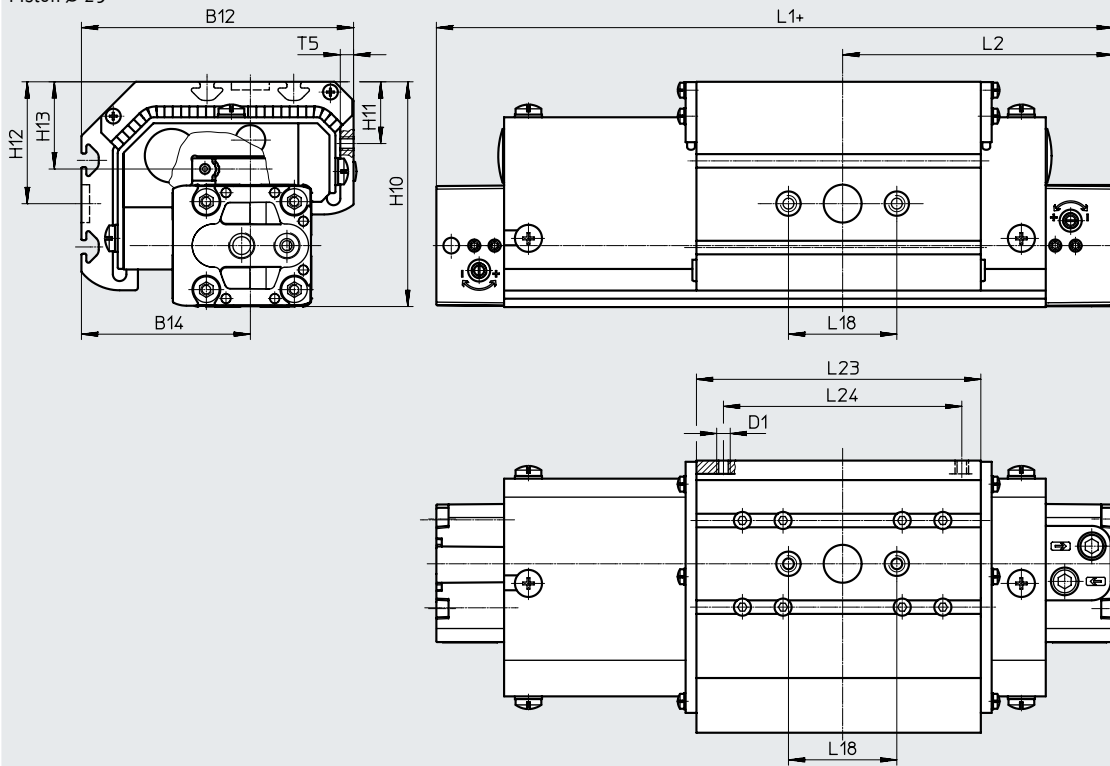

\varnothing	B1	B2	B3	B4	B5	B6	B7	B8	B9	B11	B12	B14
[mm]			+0.2									
25	45	42.2	19	39.1	18	32.5	48	67	32	9.5	100.5	62.4

\varnothing	D1	D2	D3	D4	D5	D6	D7	D8	D9	EE	H1	H2	H3
[mm]		\varnothing	\varnothing		\varnothing			\varnothing	\varnothing				
			+0.2		H10			H7	G7				
25	M5	3.3	5.2	M5	8	M4	M6	9	14	G1/8	63	57	51

\varnothing	H4	H5	H6	H7	H8	H10	H11	H12	H13	J1	J2	J3	J4
[mm]													
25	19.6	22.5	5.8	68.5	18.5	83.1	22.8	45	33.1	16.7	3.2	13	6.5

\varnothing	L1	L2	L3	L4	L5	L6	L7	L8	L9	L11	L12	L15	
[mm]	+0.9/-0.2							± 0.1	± 0.1	± 0.1	+0.9/-0.2	+0.3/-0.6	± 0.1
25	200	100	17	7	25	109	30	50	130	300	150	100	

\varnothing	L16	L17	L18	L20	L23	L24	T1	T2	T3	T5	T6	T7	T8	W1
[mm]	± 0.1	+2	± 0.03	± 0.1	+0.2						+0.2			
25	150	105	40	205	105	88	13	2	7.5	4.9	2.1	12.5	3	45°

Data sheet

Dimensions

Download CAD data → www.festo.com

Standard slide GK

Piston Ø 32 ... 80

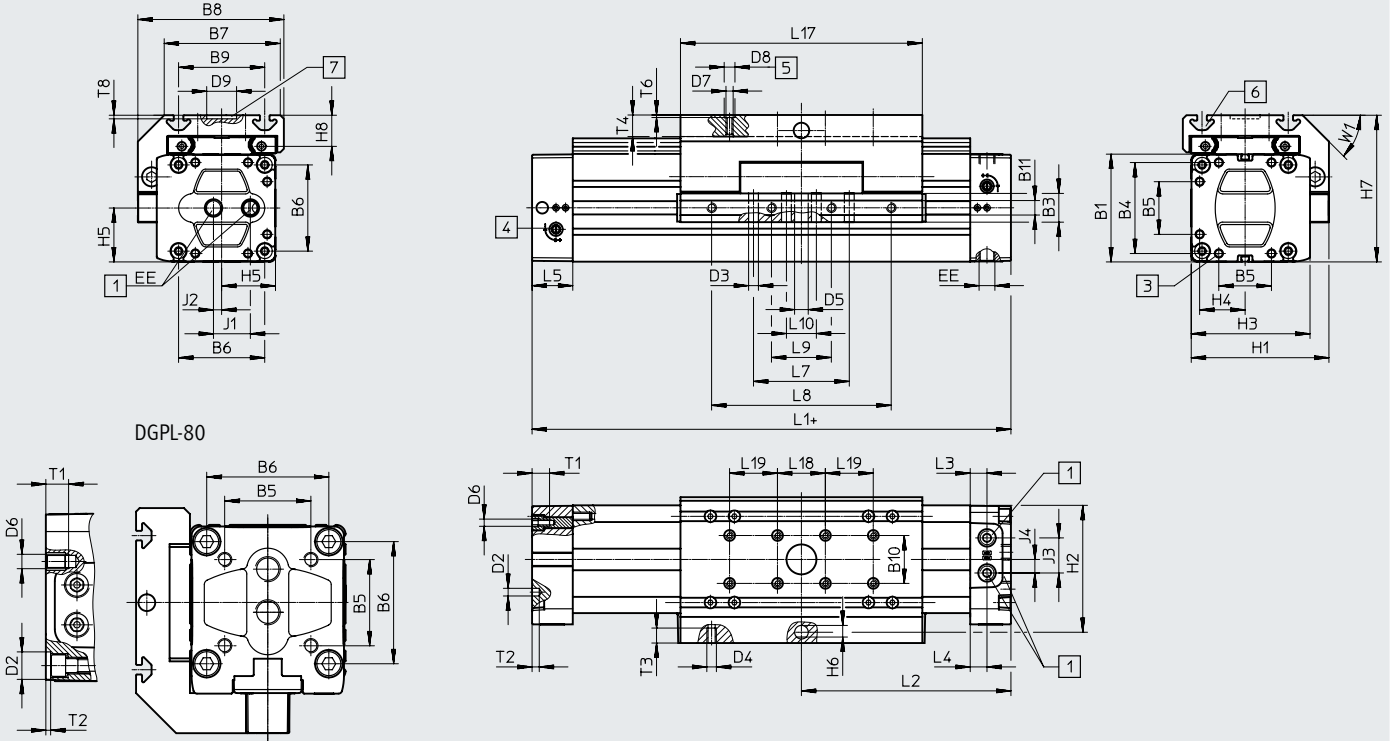

- | | | |
|---|---|--|
| <p>[1] DGPL-...:
Compressed air supply ports on one end cap, optionally on 3 sides
DGPL-...-D2:
Compressed air supply ports at both ends, optionally on 3 sides</p> | <p>[3] Centring hole for foot mounting type HP-...
[4] Adjusting screw for adjustable end-position cushioning</p> | <p>[5] Drilled hole for centring sleeve ZBH-9 + = plus stroke length
[6] Mounting slot for slot nut NSTL-25
[7] Drilled hole for central mounting SLZZ</p> |
|---|---|--|

Extended slide GV

Piston Ø 32 ... 63

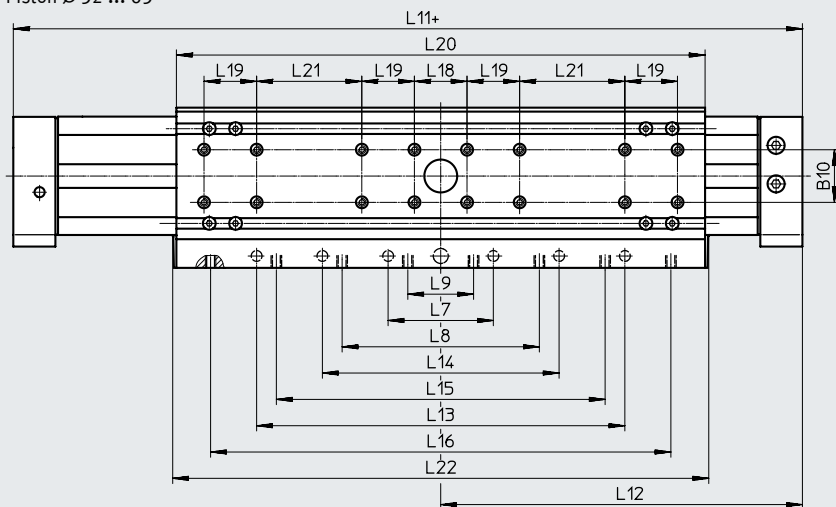

Data sheet

∅ [mm]	B1	B3 +0.2	B4	B5	B6	B7	B8	B9	B10 ±0.03	B11	D2 ∅	D3 ∅ +0.2
32	54 +0.4	19	46	21	40	63	79	47 ±0.15	20	9.5	4.3	5.2
40	64 +0.4	21	53	28	49	78.5	96.5	55 ±0.2	20	9.5	4.3	6.5
50	90 +0.4	24	76	44	72	97	122	72 ±0.2	40	12	6.3	8.5
63	106 +0.4	24	89	44	83	121	142	90 ±0.25	40	12	6.3	8.5
80	130 +0.8	36	–	72	102	151.5	188	112 +0.5/-0.2	40	–	23	12.2

∅ [mm]	D4	D5 ∅ H10	D6	D7	D8 ∅ H7	D9 ∅ G7	EE	H1	H2	H3	H4	H5	H6
32	M5	8	M5	M6	9	25	G1/8	72	66	61.8	23	27	5.8
40	M6	10	M5	M6	9	25	G1/4	86	78	71.8	26.5	32	7.7
50	M8	12	M6	M6	9	25	G1/4	115	106	99	38	45	9.7
63	M8	12	M8	M6	9	25	G3/8	131	122	115	44.5	53	9.7
80	M12	20	M12	M6	9	25	G1/2	174	158	140.5	51	85	–

∅ [mm]	H7	H8	J1	J2	J3	J4	L1 +0.9/-0.2	L2	L3	L4	L5	L6	L7
32	77.5	18.5	19	4.2	14	4.1	250	125	18.5	8.5	31	135	50 ±0.1
40	90.5	20	22	5	21	8.5	300	150	11.5	11.5	31	171	70 ±0.1
50	122.5	26	30.8	6.8	29.3	11.3	350	175	14	14	34	206	80 ±0.1
63	144.5	30	36	8	33	12	400	200	13.5	13.5	34	234	110 ±0.1
80	175	36.5	36	8	33.3	36.9	520	260	19	19	45	334	180 ±0.15

∅ [mm]	L8	L9	L10 ±0.15	L11 +0.9/-0.2	L12 +0.9/-0.2	L13 ±0.1	L14 ±0.1	L15 ±0.1	L16 ±0.1	L17	L18 ±0.03
32	100 ±0.1	30 ±0.1	–	380	190	180	–	160	230	131 +0.2	40
40	130 ±0.1	40 ±0.1	–	470	235	160	250	220	–	167 +0.2	40
50	150 ±0.1	50 ±0.1	–	550	275	280	–	250	350	202 +0.2	40
63	190 ±0.1	70 ±0.1	–	650	325	380	–	310	430	230 +0.2	40
80	230 ±0.15	115 ±0.15	60	–	–	–	–	–	–	320 -0.3	40

∅ [mm]	L19 ±0.03	L20	L21 ±0.1	L22	T1	T2	T3	T4 max.	T6 +0.1	T8	W1
32	–	261	40	265	13.2	3	7.5	12.5	2.1	3	45°
40	40	337	40	341	13.2	4	10.5	12.5	2.1	3	45°
50	40	402	80	406	15.2	6	12.5	18.5	2.1	3	45°
63	40	480	120	484	21.2	6	12.5	20.5	2.1	3	45°
80	40	–	–	–	18	4	19	27	2.1	3	45°

Data sheet

Dimensions

Download CAD data → www.festo.com

Protected version GA

Piston \varnothing 32 ... 40

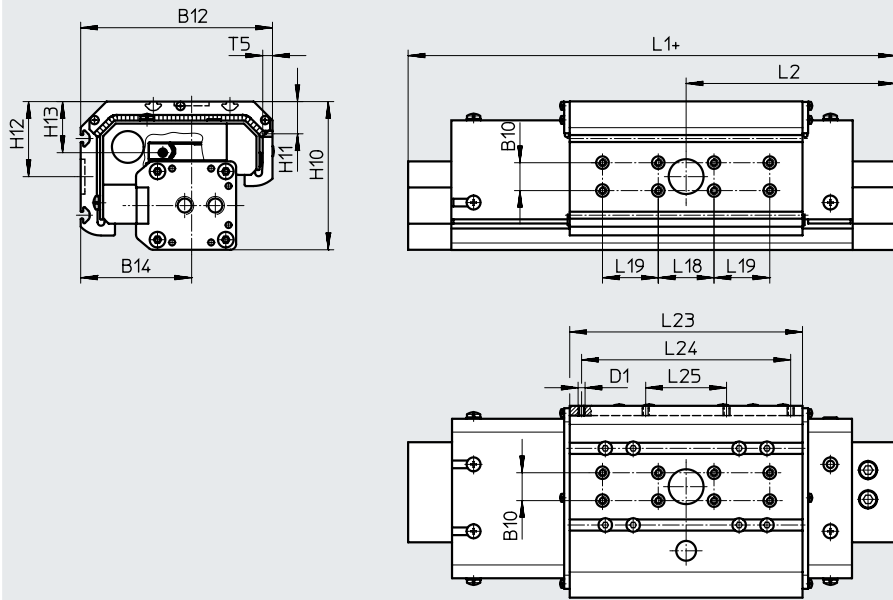

\varnothing	B10	B12	B14	D1	H10	H11	H12	H13
[mm]	± 0.03							
32	20	112.1	67.6	-	93.1	-	49.5	34.1
40	20	137.6	79.6	M5	106.6	23.1	54	36.1

\varnothing	L1	L2	L18	L19	L23	L24	L25	T5
[mm]	$+0.9/-0.2$	$+0.3/-0.6$	± 0.03	± 0.03				
32	250	125	40	-	131	-	-	-
40	300	150	40	40	167	150	58	7

Ordering data

Ordering data – Standard strokes		
Piston \varnothing	Part no.	Type
25	526649	DGPL-25-250-PPV-A-B-KF
	526650	DGPL-25-400-PPV-A-B-KF
	526651	DGPL-25-500-PPV-A-B-KF
	526652	DGPL-25-1000-PPV-A-B-KF
32	526657	DGPL-32-250-PPV-A-B-KF
	526658	DGPL-32-400-PPV-A-B-KF
	526659	DGPL-32-500-PPV-A-B-KF
	526660	DGPL-32-1000-PPV-A-B-KF
40	526665	DGPL-40-250-PPV-A-B-KF
	526666	DGPL-40-400-PPV-A-B-KF
	526667	DGPL-40-500-PPV-A-B-KF
	526668	DGPL-40-1000-PPV-A-B-KF

Ordering data – Variable strokes for recirculating ball bearing guide KF		
Piston \varnothing	Part no.	Type
18	161977	DGPL-18-...-PPV-A-KF-B
25	161792	DGPL-25-...-PPV-A-KF-B
32	161793	DGPL-32-...-PPV-A-KF-B
40	161794	DGPL-40-...-PPV-A-KF-B
50	161795	DGPL-50-...-PPV-A-KF-B
63	161796	DGPL-63-...-PPV-A-KF-B
80	161797	DGPL-80-...-PPV-A-KF-B

 **Note**

Piston \varnothing 8 and 12
 Linear drives DGC
 → Internet: dgc

Ordering data – Modular product system

Order code

Options

-  - Note: the position numbers refer to the peripheral overview → page 5

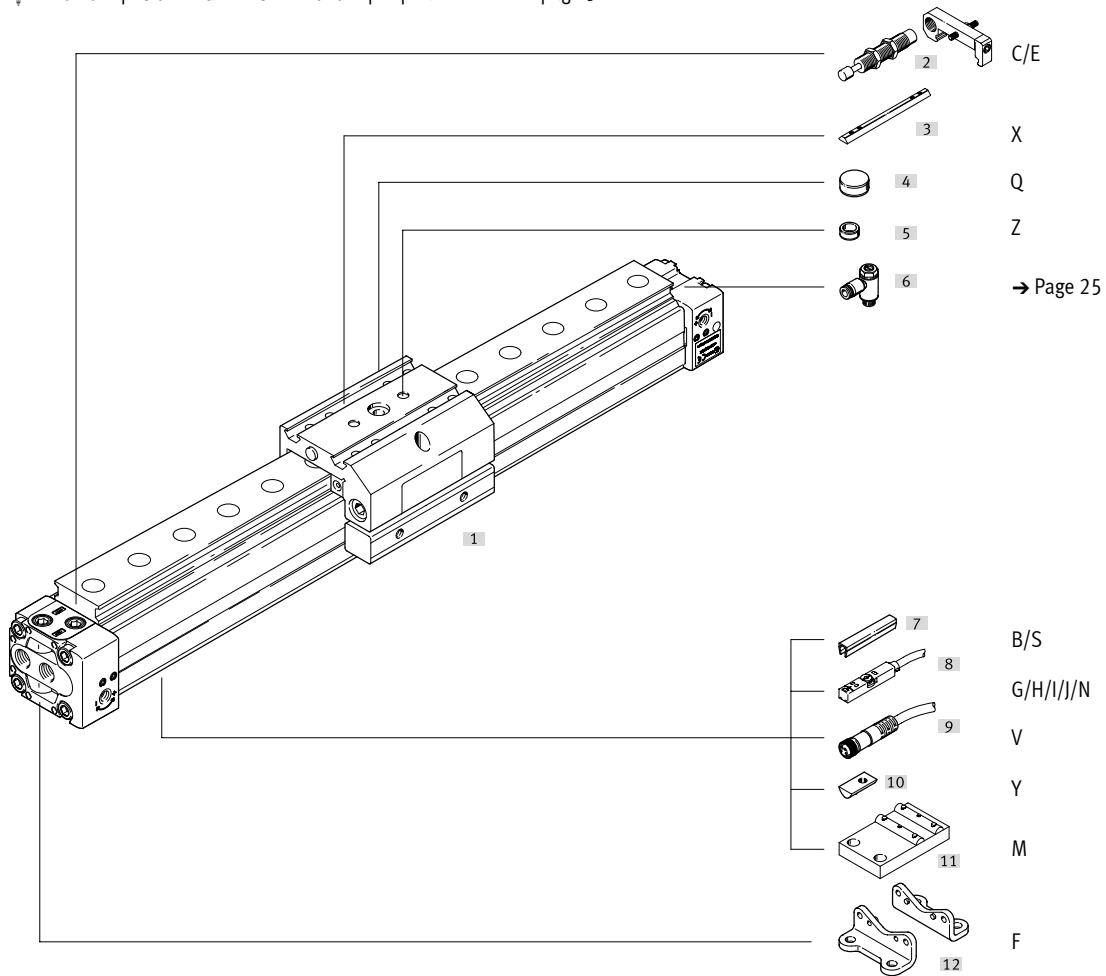

Ordering data – Modular product system

Ordering table											
Piston ø	18	25	32	40	50	63	80	Condi- tions	Code	Enter code	
Module no.	175133	175134	175135	175136	175137	175138	175139				
Function	Linear drive with slide								DGPL	DGPL	
Piston ø [mm]	18	25	32	40	50	63	80		-...		
Stroke [mm]	10 ... 1800	10 ... 3000							[1]	-...	
Cushioning	Pneumatic cushioning adjustable at both ends								-PPV	-PPV	
Position sensing	For proximity switch								-A	-A	
Generation	B series								-B	-B	
Guide	Recirculating ball bearing guide								-KF		
Basic design	Piston/slide standard								-GK		
	Extended piston/slide							-		-GV	
Slide attachment position	At rear								-SH		
	At front								-SV		
Supply port	Air supply port on both sides								-D2		

[1] Stroke For piston ø 18 with extended piston/slide GV: restricted stroke 10 ... 1750 mm.

Ordering data – Modular product system

Ordering table		18	25	32	40	50	63	80	Conditions	Code	Enter code	
Piston Ø												
Protection		Protected version								[2]	-GA	
Accessories		Enclosed separately									:ZUB-	:ZUB-
Slot cover, 2 pcs., 0.5 m	Sensor slot	1 ... 10									...S	
	Mounting slot	-	-	1 ... 10							...B	
Slot nut	Slide	-	1 ... 10								...X	
	Mounting slot	-	-	1 ... 10							...Y	
Centring sleeve (pack of 10)		10, 20, 30, 40, 50, 60, 70, 80, 90									...Z	
Central support		1 ... 10									...M	
Central mounting		-	1 ... 10								...Q	
Foot mounting		1 ... 10									...F	
Proximity switch		With cable, 2.5 m 1 ... 10									...G	
		With plug M8 1 ... 10									...H	
Proximity switch, non-contacting		-	With cable, 2.5 m 1 ... 10								...I	
		-	With plug M8 1 ... 10								...J	
Proximity switch, magnetic		N/C contact with cable, 2.5 m 1 ... 10									...N	
Connecting cable		M8, 2.5 m 1 ... 10									...V	
Shock absorber	Self-adjusting, with retainer	1 ... 10									...C	
		1 ... 10						-	-	-		...E

[2] E Only with protected version GA.

Accessories

Foot mounting HP (order code F)

Material:
Galvanised steel

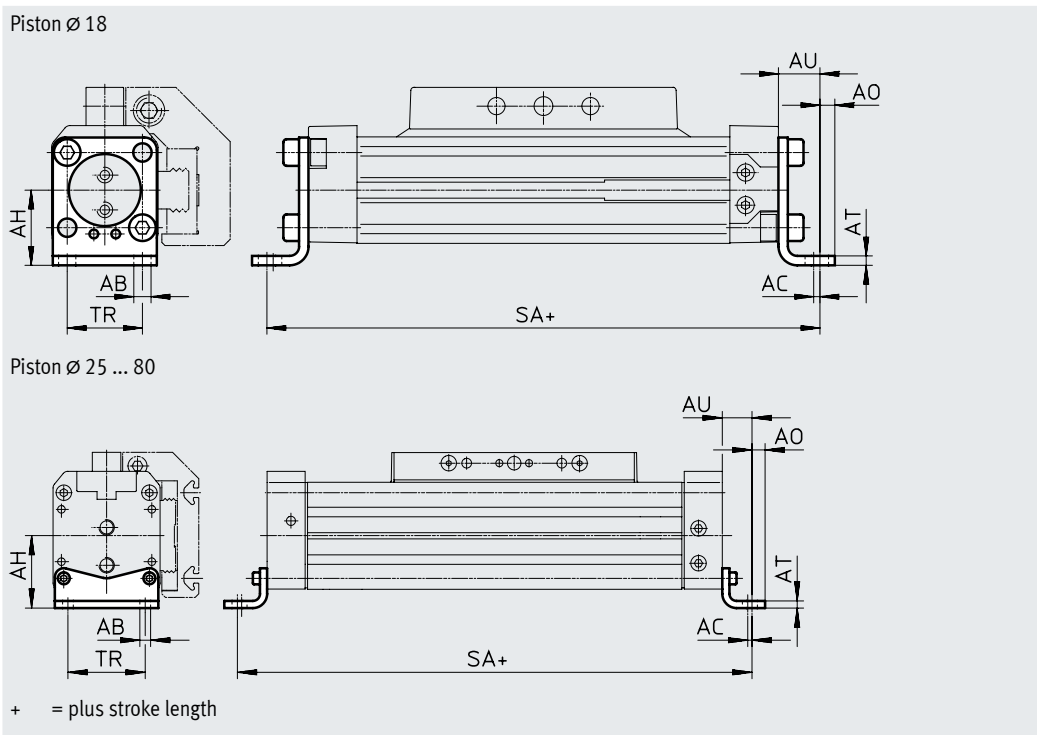
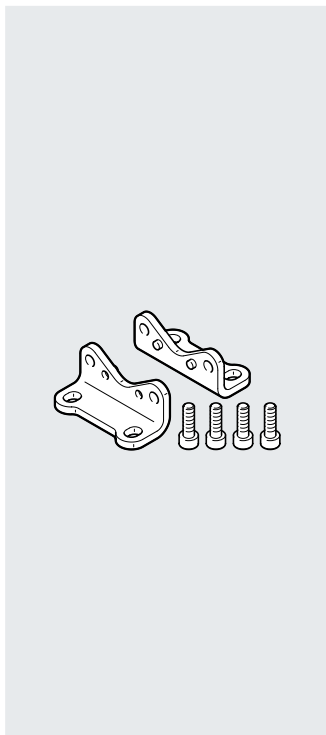

Dimensions and ordering data												
For \varnothing [mm]	AB \varnothing	AC	AH	AO	AT	AU	SA		TR	Weight [g]	Part no.	Type
							GK	GV				
18	5.5	2	24	4.8	3	13.2	176.5	256.4	24	59	158472	HP-18
25	5.5	2	29.5	6	3	13	226	326	32.5	61	150731	HP-25
32	6.6	2	37	7	4	17	284	414	38	117	150732	HP-32
40	6.6	2	46	8.5	5	17.5	335	505	45	188	150733	HP-40
50	9	3	61	11	6	25	400	600	65	243	150734	HP-50
63	11	3	69	13.5	6	28	456	706	75	305	150735	HP-63
80	13	3	85	12	8	28	576	-	72	620	158453	HP-80

Accessories

Central support MUP (order code: M)

Material:
Anodised aluminium



Piston \varnothing 18 and 25

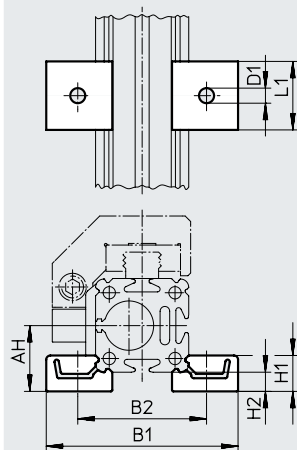

Piston \varnothing 32 ... 63

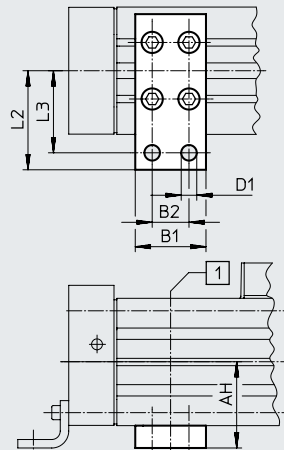

[1] Position of the central support along the profile barrel is freely selectable

Dimensions and ordering data

For \varnothing	AH	B1	B2	D1 \varnothing	H1	H2	L1	L2	L3	Weight [g]	Part no.	Type
18	24	70.5	47	5.5	13	7	25	-	-	33	150736	MUP-18/25
25	29.5	81	58	5.5	13	7	25	-	-	33	150736	MUP-18/25
32	37	35	22	6.6	-	-	-	41.5	35	89	150737	MUP-32
40	46	35	22	6.6	-	-	-	47	40	126	150738	MUP-40
50	61	50	26	11	-	-	-	70	58	241	150739	MUP-50
63	69	50	26	11	-	-	-	77	65	340	150800	MUP-63
80	85	50	26	11	-	-	-	88	76	590	158455	MUP-80

Accessories

Shock absorber YSR- ...-C

(order code: C)

Material:

Housing: Galvanised steel Piston rod:

High-alloy steel

Seals: NBR, polyurethane



- **Note**

Shock absorber YSRW with progressive characteristics → Internet: ysrw

Ordering data		Part no.	Type
For \varnothing [mm]	Weight [g]		
18	50	34571	YSR-8-8-C
25	70	34572	YSR-12-12-C
32	70	34572	YSR-12-12-C
40	140	34573	YSR-16-20-C
50	140	34573	YSR-16-20-C
63	240	34574	YSR-20-25-C
80	240	34574	YSR-20-25-C

Shock absorber retainer KYP

(order code: C)

Material:

Retainer: Aluminium

Sleeve: Corrosion-resistant steel

Shock absorber not included in scope of delivery.

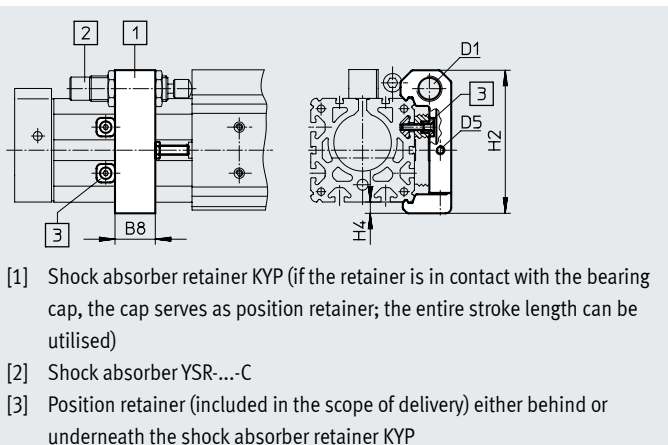

Dimensions and ordering data								
For \varnothing	B8	D1	D5	H2	H4	Weight [g]	Part no.	Type
18	14	M12x1	M4	50.5	4.5	65	158907	KYP-18
25	19	M16x1	M5	69.5	6	95	158908	KYP-25
32	25	M16x1	M5	80	8	130	158909	KYP-32
40	32	M22x1.5	M5	102	8	209	158910	KYP-40
50	35	M22x1.5	M8	124	10	415	158911	KYP-50
63	44	M26x1.5	M10	152.5	11.5	609	158912	KYP-63
80	44	M26x1.5	M10	179.5	11.5	774	158913	KYP-80

Accessories

Shock absorber DG-GA

In end position
Protected version GA
(order code: E)

Material:
Housing: Galvanised steel
Piston rod: High-alloy steel
Seals: NBR, polyurethane









Note

Entire stroke can be used.

Ordering data		Part no.	Type
For \varnothing	Weight [g]		
25	70	192875	DG-GA-25-YSR
32	93	192876	DG-GA-32-YSR
40	140	192877	DG-GA-40-YSR

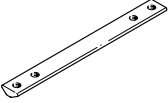
Ordering data – One-way flow control valves			Data sheets → Internet: grla		
	Connection	For tubing O.D.	Material	Part no.	Type
	Thread				
	M5	3	Metal design	193137	GRLA-M5-QS-3-D
		4		193138	GRLA-M5-QS-4-D
	G1/8	4		193143	GRLA-1/8-QS-4-D
		6		193144	GRLA-1/8-QS-6-D
	G1/4	6		193146	GRLA-1/4-QS-6-D
		8		193147	GRLA-1/4-QS-8-D
	G3/8	8		193150	GRLA-3/8-QS-8-D
		10		193151	GRLA-3/8-QS-10-D
	G1/2	12		193152	GRLA-1/2-QS-12-D

Accessories

Ordering data for DGPL		Data sheets → Internet: mounting attachment				
	For ø [mm]	Comment	Order code	Part no.	Type	PU ¹⁾
Slot nut ABAN/NST						
	18, 25	For mounting slot	Y	8003032	ABAN-1M4-5	4
	18, 25			526091	NST-HMV-M4²⁾	10
	32, 40			150914	NST-5-M5	1
	50, 63, 80			150915	NST-8-M6	
Slot nut NSTL						
	25	For slide	X	158410	NSTL-25	1
	32			158411	NSTL-32	
	40			158412	NSTL-40	
	50			158413	NSTL-50	
	63			158414	NSTL-63	
	80			161356	NSTL-80	
Centring pin/sleeve ZBS/ZBH						
	18	For slide	Z	150928	ZBS-5	10
	25 ... 80			8137184	ZBH-9-B	
Central mounting SLZZ						
	25	For slide	Q	150900	SLZZ-16/10	1
	32, 40			150901	SLZZ-25/16	
	50 ... 80			150904	SLZZ-50/40	
Slot cover ABP						
	32, 40	For mounting slot Each 0.5 m	B	151681	ABP-5	2
	50, 63, 80			151682	ABP-8	
Slot cover ABP-S						
	18 ... 80	For sensor slot Each 0.5 m	S	563360	ABP-5-S1	2

1) Packaging unit

2) In the case of piston ø 18 and 25, cannot be used with DGPL-...D2 (supply port at both ends)

Accessories

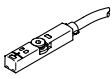
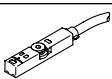
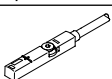
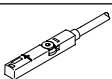
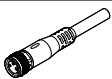
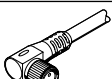
Ordering data – Proximity switch for T-slot, magneto-resistive						Data sheets → Internet: smt
	Type of mounting	Switching output	Electrical connection	Cable length [m]	Part no.	Type
N/O contact						
	Inserted in the slot from above, flush with the cylinder profile, short design	PNP	Cable, 3-wire	2.5	574335	SMT-8M-A-PS-24V-E-2.5-OE
			Plug M8x1, 3-pin	0.3	574334	SMT-8M-A-PS-24V-E-0.3-M8D
			Plug M12x1, 3-pin	0.3	574337	SMT-8M-A-PS-24V-E-0.3-M12
		NPN	Cable, 3-wire	2.5	574338	SMT-8M-A-NS-24V-E-2.5-OE
			Plug M8x1, 3-pin	0.3	574339	SMT-8M-A-NS-24V-E-0.3-M8D
N/C contact						
	Inserted in the slot from above, flush with the cylinder profile, short design	PNP	Cable, 3-wire	7.5	574340	SMT-8M-A-PO-24V-E-7.5-OE
Ordering data – Proximity switch for T-slot, magnetic reed						Data sheets → Internet: sme
	Type of mounting	Switching output	Electrical connection	Cable length [m]	Part no.	Type
N/O contact						
	Inserted in the slot from above, flush with the cylinder profile	Contacting	Cable, 3-wire	2.5	543862	SME-8M-DS-24V-K-2.5-OE
				5.0	543863	SME-8M-DS-24V-K-5.0-OE
			Cable, 2-wire	2.5	543872	SME-8M-ZS-24V-K-2.5-OE
				Plug M8x1, 3-pin	0.3	543861
N/C contact						
	Inserted in the slot from above, flush with the cylinder profile	Contacting	Cable, 3-wire	7.5	546799	SME-8M-DO-24V-K-7.5-OE
Ordering data – Connecting cables						Data sheets → Internet: nebu
	Electrical connection, left	Electrical connection, right	Cable length [m]	Part no.	Type	
	Straight socket, M8x1, 3-pin	Cable, open end, 3-wire	2.5	541333	NEBU-M8G3-K-2.5-LE3	
			5.0	541334	NEBU-M8G3-K-5-LE3	
	Straight socket, M12x1, 5-pin		2.5	541363	NEBU-M12G5-K-2.5-LE3	
			5.0	541364	NEBU-M12G5-K-5-LE3	
	Angled socket, M8x1, 3-pin	Cable, open end, 3-wire	2.5	541338	NEBU-M8W3-K-2.5-LE3	
			5.0	541341	NEBU-M8W3-K-5-LE3	
	Angled socket, M12x1, 5-pin		2.5	541367	NEBU-M12W5-K-2.5-LE3	
			5.0	541370	NEBU-M12W5-K-5-LE3	