









Linear drives DDLI, with integrated displacement encoder

FESTO



Product range overview

Function	Type	Description	
Drives	Rodless		
	DDLI	<ul style="list-style-type: none"> • Without guide • With displacement encoder for contactless measurement • Based on linear drive DGC-K • Supply ports on end face • System product for handling and assembly technology 	
			
	DGCI	<ul style="list-style-type: none"> • With guide • With displacement encoder for contactless measurement • Based on linear drive DGC • Supply ports optionally on end face or front • System product for handling and assembly technology 	
			
	With piston rod		
	DNCI	<ul style="list-style-type: none"> • With displacement encoder for contactless measurement • Various piston rod variants • Standards-based cylinder to ISO 15552 	
			
DDPC	<ul style="list-style-type: none"> • With displacement encoder for contactless measurement • Various piston rod variants • Standards-based cylinder to ISO 15552 		
			
DNC/DSBC	<ul style="list-style-type: none"> • With attached potentiometer MLO-LWG • Various piston rod variants • Standards-based cylinder to ISO 15552 		
			
Swivel module	Swivel module	<ul style="list-style-type: none"> • Based on swivel module DSM • Integrated rotary potentiometer • Compact design • Wide range of mounting options 	
			

Product range overview

Piston diameter	Stroke/swivel angle [mm/°]	Suitable			for use as a measuring cylinder
		for positioning with	for end-position controller		
		CPX-CMAX	CPX-CMPX	SPC11	
Rodless					
25, 32, 40, 63	100, 160, 225, 300, 360, 450, 500, 600, 750, 850, 1000, 1250, 1500, 1750, 2000	■	■	■	■
18, 25, 32, 40, 63	100, 160, 225, 300, 360, 450, 500, 600, 750, 850, 1000, 1250, 1500, 1750, 2000	■	■	■	■
With piston rod					
32, 40, 50, 63	10 ... 2000	–	–	–	■
	100 ... 750	■	■	■	–
80, 100	10 ... 2000	–	–	–	■
	100 ... 750	■	■	■	–
32, 40, 50, 63, 80	100, 150, 225, 300, 360, 450, 600, 750	■	■	■	■
Swivel module					
25, 40, 63	270	■	■	■	■

Key features

Servo-pneumatic drive technology

Positioning and Soft Stop applications as an integral component of the valve terminal CPX – the modular peripheral system for decentralised automation tasks. The modular design means that valves, digital inputs and outputs, positioning modules and end-position controllers, as appropriate to the application, can be combined in almost any way on the CPX terminal.

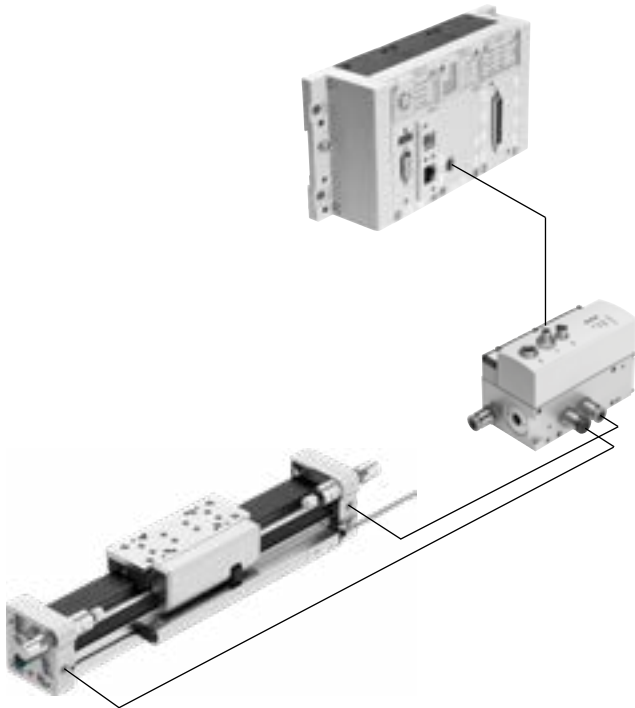

Advantages:

- Pneumatics and electrics – control and positioning on one platform
- Innovative positioning technology – piston rod drives, rodless drives, rotary drives
- Actuation via fieldbus
- Remote maintenance, remote diagnostics, web server, SMS and e-mail alerts are all possible via TCP/IP
- Modules can be quickly exchanged and expanded without altering the wiring

Axis controller CPX-CMAX



Free choice:
Position and force control, directly actuated or selected from one of 128 configurable position sets.
If you are looking for something more:
The configurable record sequencing function enables simple functional sequences to be realised in the axis controller CPX-CMAX.
Everything is recognisable:
The auto-identification function identifies each participant with its device data on the controller CPX-CMAX.

Also included:
Actuation of a brake or clamping unit via the proportional directional control valve VPWP is also part of the scope of performance of the controller CPX-CMAX.
Up to 8 modules (max. 8 axes) can be operated in parallel and independently of each other.
Commissioning via FCT (Festo configuration software) or via fieldbus: no programming, only configuration.

Advantages:

- Greater flexibility
- OEM friendly – commissioning also via fieldbus
- Easy installation and fast commissioning
- Cost-effective
- You program the system in your PLC environment

Key features

End-position controllers CPX-CMPX

Data sheets → Internet: [cpx-cmpx](#)

Fast travel between the mechanical end stops of the cylinder, stopping gently and without impact in the end position.
 Fast commissioning via control panel, fieldbus or handheld unit.
 Improved standstill control.
 Actuation of a brake or clamping unit via the proportional directional control valve VPWP is an integral part of the controller CMPX.

Depending on the fieldbus chosen, up to 9 end-position controllers can be actuated on the CPX terminal.
 All system data can be read and written via the fieldbus, including, for example, the mid-positions.

Advantages:

- Greater flexibility
- OEM friendly – commissioning also via fieldbus
- Easy installation and fast commissioning
- Cost-effective
 - Up to 30% faster cycle rates
 - Significantly reduced system vibration
- Improved work ergonomics thanks to significantly reduced noise level
- The extended diagnostics help to reduce the service time of the machine

Proportional directional control valve VPWP

Data sheets → Internet: [vpwp](#)

The 5/3-way proportional directional control valve for applications with Soft Stop and pneumatic positioning.
 Fully digitalised – with integrated pressure sensors, with new diagnostic functions.
 In sizes 4, 6, 8 and 10.
 Flow rates of 350, 700, 1400 and 2000 l/min.

With switching output for controlling a brake.
 Colour-coded supply ports.
 Pre-assembled cables guarantee faultless and fast connection with the controllers CPX-CMPX and CPX-CMAX.

Advantages:

- Easy installation and fast commissioning
- Reduction of system downtimes thanks to the new diagnostic options
- With switching output for controlling a brake/clamping unit

Measuring module CPX-CMIX

Data sheets → Internet: [cpx-cmix](#)

Fully digital data acquisition and transmission means that pneumatic cylinders can be used as sensors. With very high repetition accuracy and incorporating both analogue and digital measuring sensors.

Suitable for the linear drive DGCI with displacement encoder for measuring absolute values, for the piston rod drive DNCI/DDPC with incremental displacement encoder or alternatively for a potentiometer of the type MLO.

Advantages:

- All process steps can be documented, which improves quality
- An adjustable contact force (via pressure regulator) increases the precision of the "displacement sensor"
- With displacement encoders for measuring absolute values, the actual position is immediately available after the system is switched on

Drive options

System with linear drive DDLI, DGCI

Data sheets → Internet: [ddli](#) or [dgc](#)

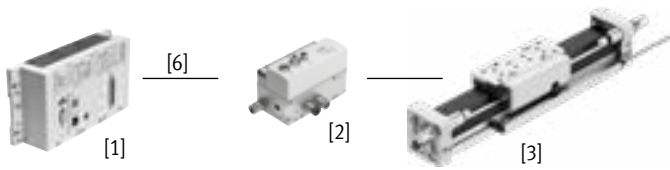

- [1] Controller module CPX-CMPX or CPX-CMAX
- [2] Proportional directional control valve VPWP
- [3] Linear drive DDLI, DGCI with displacement encoder
- [6] Connecting cable KVI-CP-3-...

- Pneumatic rodless linear drive with displacement encoder, with or without recirculating ball bearing guide
- Displacement encoder with absolute and contactless measurement
- Diameter:
 - With DGCI: 18 ... 63 mm
 - With DDLI: 25 ... 63 mm
- Stroke: 100 ... 2000 mm in fixed lengths
- Range of applications: Soft Stop and pneumatic positioning
- Loads from 1 ... 180 kg
- No sensor interface required

Advantages:

- Complete drive unit
- DDLI for easy connection to the customer's guide system
- Excellent running characteristics
- For fast and accurate positioning up to ±0.2 mm (only with axis controller CPX-CMAX)

System with standards-based cylinder DNCI, DDPC

Data sheets → Internet: [dnci](#)

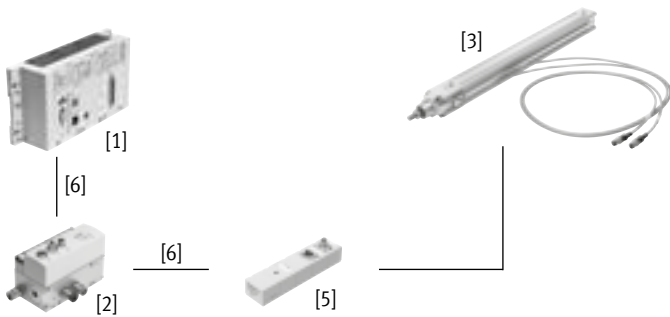

- [1] Controller module CPX-CMPX or CPX-CMAX
- [2] Proportional directional control valve VPWP
- [3] Standards-based cylinder DNCI, DDPC with displacement encoder
- [5] Sensor interface CASM-S-D3-R7
- [6] Connecting cable KVI-CP-3-...

- Standards-based cylinder with integrated displacement encoder, conforms to DIN ISO 6432, VDMA 24 562, NF E 49 003.1 and Uni 10 290
- Displacement encoder with contactless and incremental measurement
- Diameter: 32 ... 100 mm
- Stroke: 100 ... 750 mm
- Range of applications: Soft Stop and pneumatic positioning
- Loads from 3 ... 450 kg and the corresponding sensor interface CASM-S-D3-R7
- Pre-assembled cables guarantee faultless and fast electrical connection

Advantages:

- Compact drive unit
- Can be used universally
- Also with guide unit
- For fast and accurate positioning up to ±0.5 mm (only with axis controller CPX-CMAX)

Drive options

System with swivel module DSMI

Data sheets → Internet: dsmi

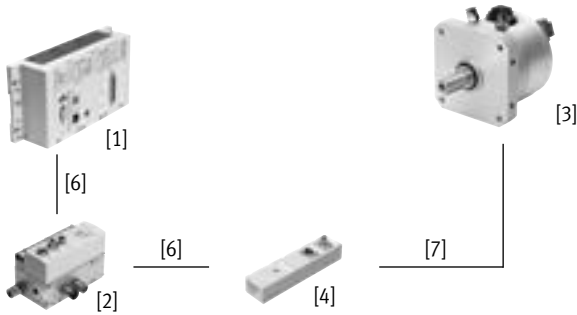

- [1] Controller module CPX-CMPX or CPX-CMAX
- [2] Proportional directional control valve VPWP
- [3] Swivel module DSMI with displacement encoder
- [4] Sensor interface CASM-S-D2-R3
- [6] Connecting cable KVI-CP-3-...
- [7] Connecting cable NEBC-P1W4-K-0.3-N-M12G5

- Swivel module DSMI with integrated displacement encoder
- Identical design to pneumatic swivel module DSM
- Absolute displacement encoder based on a potentiometer
- Swivel range from 0 ... 270°
- Size: 25, 40, 63
- Max. torque: 5 ... 40 Nm
- Range of applications: Soft Stop and pneumatic positioning
- Mass moments of inertia of 15 ... 6000 kgcm² and the corresponding sensor interface CASM-S-D2-R3
- Pre-assembled cables guarantee faultless and fast connection to the proportional directional control valve VPWP

Advantages:

- Complete drive unit, compact, can be used immediately
- High angular acceleration
- With adjustable fixed stops
- For fast and accurate positioning down to ±0.2° (only with axis controller CPX-CMAX)

System with potentiometer

Data sheets → Internet: casm

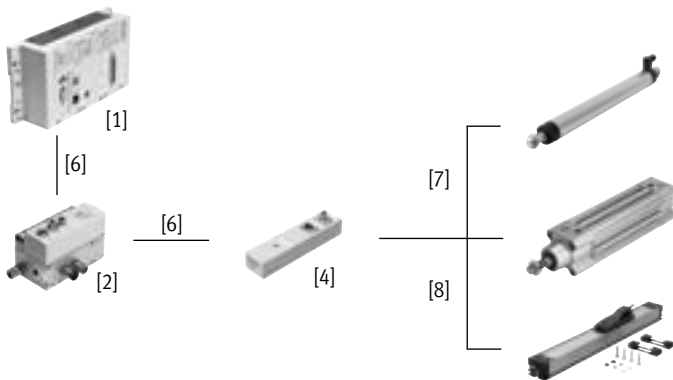

- [1] Controller module CPX-CMPX or CPX-CMAX
- [2] Proportional directional control valve VPWP
- [4] Sensor interface CASM-S-D2-R3
- [6] Connecting cable KVI-CP-3-...
- [7] Connecting cable NEBC-P1W4-K-0.3-N-M12G5
- [8] Connecting cable NEBC-A1W3-K-0.4-N-M12G5

- Attachable potentiometers with absolute measurement, with high degree of protection
- With connecting rod or moment compensator
- Measuring range:
Connecting rod: 100 ... 750 mm
Moment compensator: 225 ... 2000 mm
- Pre-assembled cables guarantee faultless and fast connection with the sensor interface CASM
- Range of applications: Soft Stop and pneumatic positioning with cylinder diameters of 25 ... 80 mm
- Loads from 1 ... 300 kg

Advantages:

- Easy installation and fast commissioning
- Cost-effective
- Can also be used in harsh ambient conditions
- Variety of drives: CPX-CMPX and CPX-CMAX also support cylinders with external displacement encoder

Drive options

System components for Soft Stop systems with end-position controller CPX-CMPX						
	Linear drive	Standards-based cylinder	Swivel module	Displacement encoder		→ Page/ Internet
	DDL/DGCI	DNCI, DDPC	DSMI	MLO-LWG/-TLF	MME-MTS	
End-position controller CPX-CMPX	■	■	■	■	■	cmpx
Proportional directional control valve VPWP	■	■	■	■	■	vpwp
Sensor interface CASM-S-D2-R3	–	–	■	■	–	casm
Sensor interface CASM-S-D3-R7	–	■	–	–	–	casm
Connecting cable KVI-CP-3-...	■	■	■	■	■	kvi
Connecting cable NEBC-P1W4-...	–	–	■	■ / –	–	nebc
Connecting cable NEBC-A1W3-...	–	–	–	– / ■	–	nebc
Connecting cable NEBP-M16W6-...	–	–	–	–	■	vpwp

System components for pneumatic positioning systems with axis controller CPX-CMAX						
	Linear drive	Standards-based cylinder	Swivel module	Displacement encoder		→ Page/ Internet
	DDL/DGCI	DNCI, DDPC	DSMI	MLO-LWG/-TLF	MME-MTS	
Axis controller CPX-CMAX	■	■	■	■	■	cmax
Proportional directional control valve VPWP	■	■	■	■	■	vpwp
Sensor interface CASM-S-D2-R3	–	–	■	■	–	casm
Sensor interface CASM-S-D3-R7	–	■	–	–	–	casm
Connecting cable KVI-CP-3-...	■	■	■	■	■	kvi
Connecting cable NEBC-P1W4-...	–	–	■	■ / –	–	nebc
Connecting cable NEBC-A1W3-...	–	–	–	– / ■	–	nebc
Connecting cable NEBP-M16W6-...	–	–	–	–	■	vpwp

System components for measuring cylinders with measuring module CPX-CMIX						
	Linear drive	Standards-based cylinder	Swivel module	Displacement encoder		→ Page/ Internet
	DDL/DGCI	DNCI, DDPC	DSMI	MLO-LWG/-TLF	MME-MTS	
Measuring module CPX-CMIX-M1-1	■	■	■	■	■	cmix
Sensor interface CASM-S-D2-R3	–	–	■	■	–	casm
Sensor interface CASM-S-D3-R7	–	■	–	–	–	casm
Connecting cable KVI-CP-3-...	(■) ¹⁾	■	■	■	(■)	kvi
Connecting cable NEBC-P1W4-...	–	–	■	■ / –	–	nebc
Connecting cable NEBC-A1W3-...	–	–	–	– / ■	–	nebc
Connecting cable NEBP-M16W6-...	–	–	–	–	■	vpwp

1) As an extension

Type codes

001	Series	
DDLI	Linear drive, integrated displacement encoder	
002	Piston diameter	
25	25	
32	32	
40	40	
63	63	
003	Stroke	
...	100 ... 2000	
004	Cushioning	
P	Elastic cushioning rings/plates on both sides	
005	Lubrication	
	Standard	
H1	Food-safe lubrication	
006	Foot mounting	
	None	
MF	1 record	
007	Profile mounting	
	None	
...MA	1 ... 10 units	

008	Cover, sensor slot	
	None	
NS	1 record	
009	Cover, mounting slot	
	None	
NC	1 record	
010	Slot nut for mounting slot	
	None	
...NM	1 ... 50 units	
011	Moment compensator	
	None	
T	Moment compensator coupling DARD	
012	Adapter plate	
	None	
AP	FKP interface	
013	Operating instructions	
	With operating instructions	
DN	Without operating instructions	

Peripherals overview

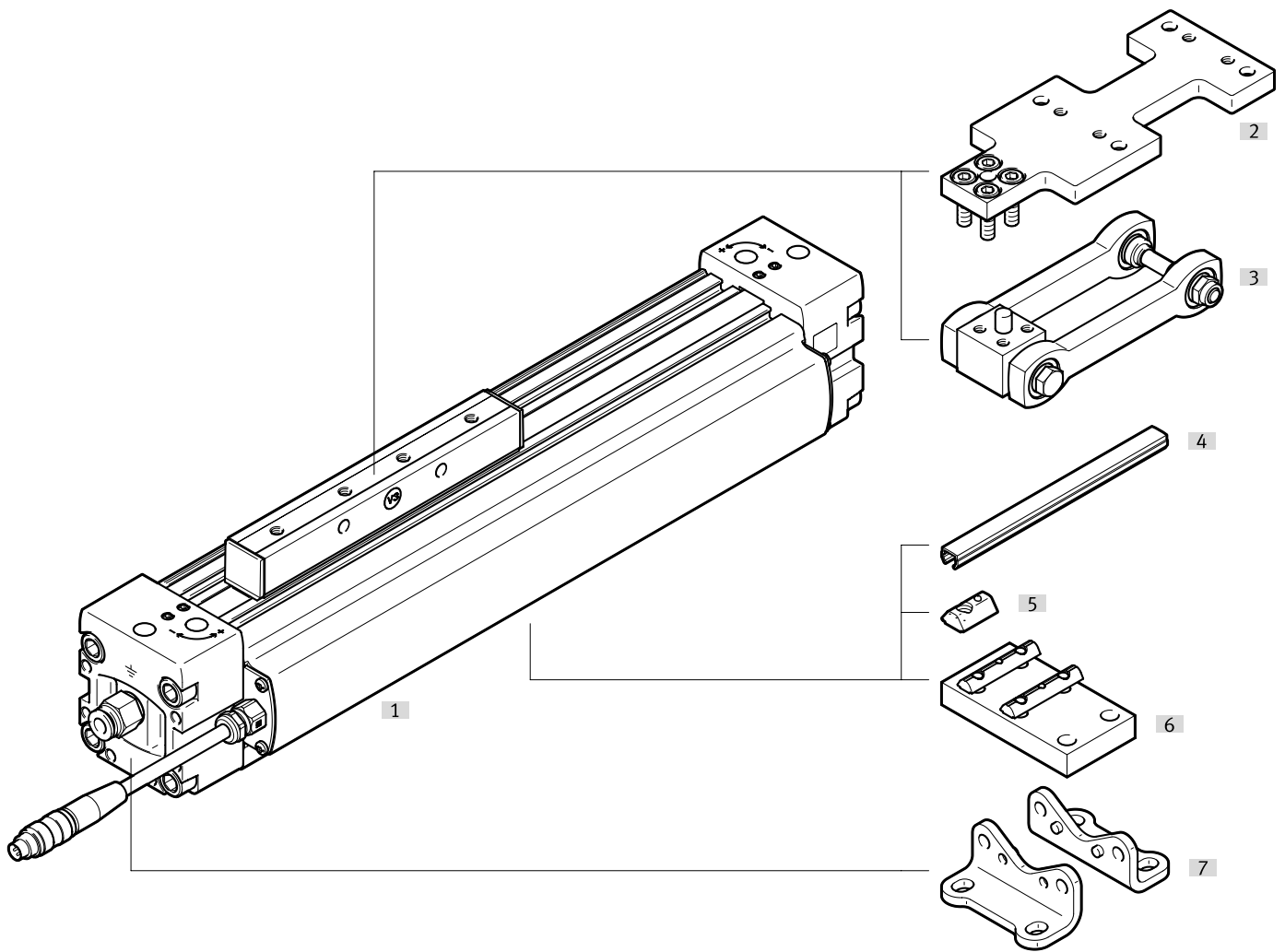

Peripherals overview

Accessories		
Type	Description	→ Page/Internet
[1] Linear drive DDLI	With integrated displacement encoder	12
[2] Adapter plate DAMF	Has the same interface as the moment compensator FKP for the linear drive DGP	23
[3] Moment compensator DARD	For compensating misalignments when using external guides	22
[4] Slot cover ABP	For protection against contamination	24
[5] Slot nut ABAN, NST	For mounting attachments	24
[6] Central support MUP	For mounting the axis, particularly for long stroke lengths	21
[7] Foot mounting HP	For mounting the axis. The foot mounting cannot be used when the bottom mounting position is used for the displacement encoder	21

 **Note**

Allocation table of drives and associated proportional directional control valves
→ page 24

Data sheet

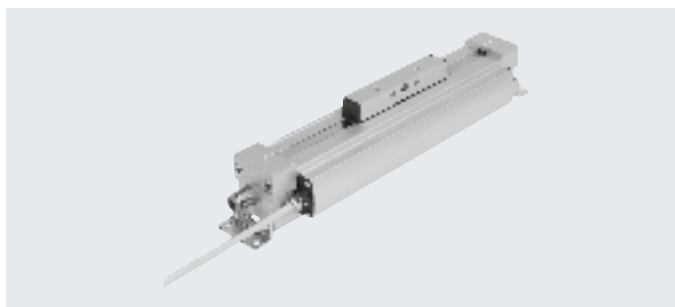
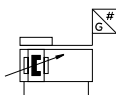

- Diameter
25 ... 63 mm
- Stroke length
100 ... 2000 mm

General technical data				
Piston diameter	25	32	40	63
Design	Rodless linear drive with slide and displacement encoder			
Mode of operation	Double-acting			
Moment compensator principle	Slotted cylinder, mechanically coupled			
Mounting position	Any			
Type of mounting	Central support			
	Foot mounting			
	Direct mounting			
Cushioning	Elastic cushioning rings/pads at both ends			
Position sensing	Via integrated displacement encoder			
Measuring principle (displacement encoder)	Digital, magnetostrictive, contactless and absolute measurement			
Pneumatic connection ¹⁾	G1/8		G1/4	G3/8
Stroke ²⁾	[mm]	100, 160, 225, 300, 360, 450, 500, 600, 750, 850, 1000, 1250, 1500, 1750, 2000		
Max. speed	[m/s]	3		

- 1) For pre-assembled push-in fittings, the tubing fittings → page 15 apply
- 2) Note stroke reduction in combination with CPX-CMAX

Operating and environmental conditions				
Piston diameter	25	32	40	63
Operating pressure	[MPa]	0.2 ... 0.8		0.15 ... 0.8
	[bar]	2 ... 8		1.5 ... 8
	[psi]	29 ... 116		21.75 ... 116
Operating pressure ¹⁾	[MPa]	0.4 ... 0.8		
	[bar]	4 ... 8		
	[psi]	58 ... 116		
Operating medium ²⁾	Compressed air to ISO 8573-1:2010 [6:4:4]			
Note on the operating/pilot medium	Operation with lubricated medium not possible Pressure dew point 10°C below ambient temperature/temperature of medium			
Ambient temperature	[°C]	-10 ... +60		
Vibration resistance to DIN/IEC 68 Part 2-6	At 10 ...60 Hz: 0.15 mm			
	At 60 ...150 Hz: 2G			
Continuous shock resistance to DIN/IEC 68, Part 2-27	Half sine 15 g, 11 ms			
CE marking (see declaration of conformity) ³⁾	To EU EMC Directive			
Certification	RCM trademark			
Corrosion resistance class CRC ⁴⁾	1			

- 1) Only applies to applications with end-position controller CPX-CMPX, SPC11 and axis controller CPX-CMAX
- 2) The proportional directional control valve VPWP, MPYE used requires these characteristic values
- 3) For information about the area of use, see the EC declaration of conformity: www.festo.com/sp → Certificates.
If the devices are subject to usage restrictions in residential, commercial or light-industrial environments, further measures for the reduction of the emitted interference may be necessary.
- 4) Corrosion resistance class CRC 1 to Festo standard FN 940070
Low corrosion stress. Dry indoor application or transport and storage protection. Also applies to parts behind coverings, in the non-visible interior area, and parts which are covered in the application (e.g. drive trunnions).

Data sheet

Forces [N] and impact energy [Nm]				
Piston diameter	25	32	40	63
Theoretical force at 0.6 MPa (6 bar, 87 psi)	295	483	754	1870
Impact energy at the end positions	0.05	0.12	0.25	0.5

Positioning characteristics with axis controller CPX-CMAX				
Piston diameter	25	32	40	63
Mounting position	Any			
Resolution [mm]	0.01			
Repetition accuracy	→ Page 15			
Minimum load, horizontal ¹⁾ [kg]	2	3	5	12
Maximum load, horizontal ¹⁾ [kg]	30	50	75	180
Minimum load, vertical ¹⁾ [kg]	2	3	5	12
Maximum load, vertical ¹⁾ [kg]	10	15	25	60
Min. travel speed [m/s]	0.05			
Max. travel speed [m/s]	3			
Typical positioning time, long stroke ²⁾ [s]	0.6 5/1.00	0.6 5/1.05	0.7 0/1.05	1.0 5/1.2
Typical positioning time, short stroke ³⁾ [s]	0.3 8/0.60	0.3 8/0.60	0.3 8/0.60	0.6 5/0.65
Minimum positioning stroke ⁴⁾ [%]	≤ 3			
Stroke reduction ⁵⁾ [mm]	25	25	35	35
Recommended proportional directional control valve				
For CPX-CMAX	→ Page 24			

- 1) Load = payload + load of all moving parts on the drive
- 2) At 0.6 MPa (6 bar, 87 psi), horizontal mounting position, DDLI-XX-1000, 800 mm positioning travel at min./max. load
- 3) At 0.6 MPa (6 bar, 87 psi), horizontal mounting position, DDLI-XX-1000, 100 mm positioning travel at min./max. load
- 4) In relation to the maximum stroke of the drive, but never more than 20 mm.
- 5) The stroke reduction must be maintained on each side of the drive, the max. positionable stroke is thus: stroke – 2x stroke reduction

Force control characteristics with axis controller CPX-CMAX				
Piston diameter	25	32	40	63
Mounting position	Any			
Maximum controllable force ¹⁾ [N]	266	435	679	1683
Typical friction forces ²⁾ [N]	20	30	40	50
Repetition accuracy of pressure control ³⁾⁴⁾ [%]	< ±2			

- 1) Advancing/retracting at 0.6 MPa (6 bar, 87 psi)
- 2) These values can fluctuate greatly from cylinder to cylinder and are not guaranteed.
These friction forces must also be taken into consideration when using an external guide or when the cylinder is moving other components subject to friction
- 3) This value defines the repetition accuracy with which the internal differential pressure in the cylinder, which corresponds to the prescribed force setpoint value, is controlled and refers to the maximum controllable force
- 4) The effective force at the workpiece and its accuracy depend largely on the friction in the system as well as the repetition accuracy of the internal control system. Note that friction forces always work against the direction of movement of the piston. The following formula can be used as a rule of thumb to approximate the force F at the workpiece:

$$F = F_{\text{setpoint}} \pm F_{\text{friction forces}} \pm \text{repetition accuracy of pressure control}$$

Data sheet

Positioning characteristics with Soft Stop end-position controller CPX-CMPX, SPC11					
Piston diameter		25	32	40	63
Mounting position		Any			
Repetition accuracy ¹⁾	[mm]	±2			
Minimum load, horizontal ²⁾	[kg]	2	3	5	12
Maximum load, horizontal ²⁾	[kg]	30	50	75	180
Minimum load, vertical ²⁾	[kg]	2	3	5	12
Maximum load, vertical ²⁾	[kg]	10	15	25	60
Travel time		→ SoftStop engineering software: → www.festo.com			
Recommended proportional directional control valve					
For CPX-CMPX		→ Page 25			
For SPC11		→ Page 26			

1) One intermediate position. The accuracy in the end positions depends solely on the design of the end stops

2) Load = payload + load of all moving parts on the drive

Electrical data – Displacement encoder	
Output signal	Digital
Linearity error ¹⁾	[%] < ±0.02, min. ±50 µm
Max. travel speed	[m/s] 3
Degree of protection	IP67
CE marking (see declaration of conformity)	To EU EMC Directive ²⁾
Power supply	[V DC] 24 (±25%)
Current consumption	[mA] Typically 100
Max. temperature coefficient	[ppm/°K] 15
Electrical connection	Cable with 5-pin plug, round type, M9
Cable length	[m] 1.5
Cable quality	Suitable for use with energy chains

1) Always refers to max. stroke.

2) For information about the area of use, see the EC declaration of conformity at: www.festo.com/sp → Certificates.

If the devices are subject to usage restrictions in residential, commercial or light-industrial environments, further measures for the reduction of the emitted interference may be necessary.

Pin allocation

Plugs

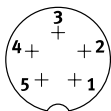

Pin	Function
1	+24 V
2	–
3	0 V
4	CAN_H
5	CAN_L
Housing	Cable shielding

Data sheet

Weight [g]				
Piston diameter	25	32	40	63
Basic weight with 0 mm stroke	1103	1716	2580	8730
Additional weight per 10 mm stroke	34	43	58	139
Moving mass	130	227	350	1669

Materials

Sectional view

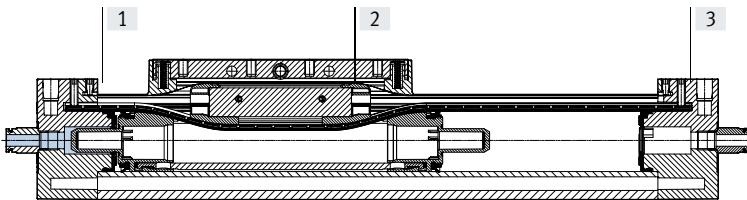

Linear actuators

[1] Cylinder profile, housing	Anodised aluminium
[2] Slide	Anodised aluminium
[3] End cap	Painted aluminium
- Seals	NBR, TPE-U(PU)
- Cable	PUR
- Note on materials	RoHS-compliant
- PWIS conformity	VDMA24364-B2-L

Repetition accuracy x as a function of stroke l

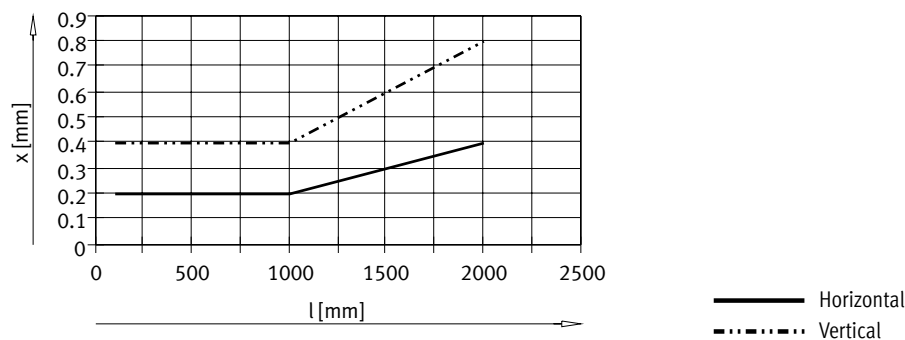

Tubing O.D. of pre-assembled push-in fittings

Size	Stroke [mm]	ø in [mm]			
		6	8	10	12
DDLI-25	100 ... 160	■	-	-	-
	225 ... 2000	-	■	-	-
DDLI-32	100	■	-	-	-
	160 ... 2000	-	■	-	-
DDLI-40	100 ... 750	-	■	-	-
	850 ... 2000	-	-	■	-
DDLI-63	100 ... 300	-	■	-	-
	360 ... 450	-	-	■	-
	500 ... 2000	-	-	-	■

Data sheet

Characteristic load values

The indicated forces and torques refer to the surface of the slide.

These values must not be exceeded during dynamic operation. Special attention must be paid to the deceleration phase.

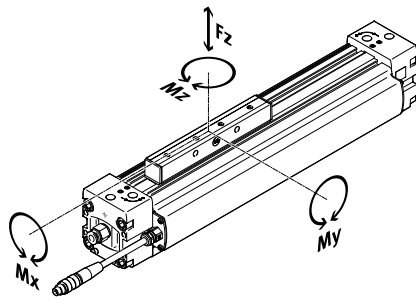

If the drive is subjected to two or more of the indicated forces and torques simultaneously, the following equation must be satisfied in addition to the indicated maximum loads:

$$0,4 \cdot \frac{F_{z1}}{F_{z2}} + \frac{M_{x1}}{M_{x2}} + \frac{M_{y1}}{M_{y2}} + 0,2 \cdot \frac{M_{z1}}{M_{z2}} \leq 1$$

$$\frac{F_{z1}}{F_{z2}} \leq 1$$

$$\frac{M_{z1}}{M_{z2}} \leq 1$$

F1/M1 = dynamic value
F2/M2 = maximum value

Permissible forces and torques					
Piston diameter		25	32	40	63
F _z _{max.}	[N]	330	480	800	1600
M _x _{max.}	[Nm]	1.2	1.9	3.8	5.7
M _y _{max.}	[Nm]	20	40	60	150
M _z _{max.}	[Nm]	3	5	8	24

Data sheet

Number of central supports MUP as a function of overall length

Excessive distances between the central supports can reduce the positioning accuracy. The following table shows the required minimum number of central supports and foot mountings.

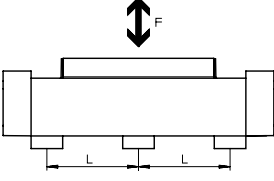
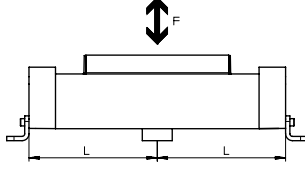
Stroke [mm]	Number of mounting components			
	Order code MA		Order code MF	
	Central support	Foot mounting + central support		
				
100 ... 400	2	2	0	
401 ... 600	2	2	1	
601 ... 1200	3	2	1	
1201 ... 1400	3	2	2	
1401 ... 2000	4	2	2	

Data sheet

Dimensions

Download CAD data → www.festo.com

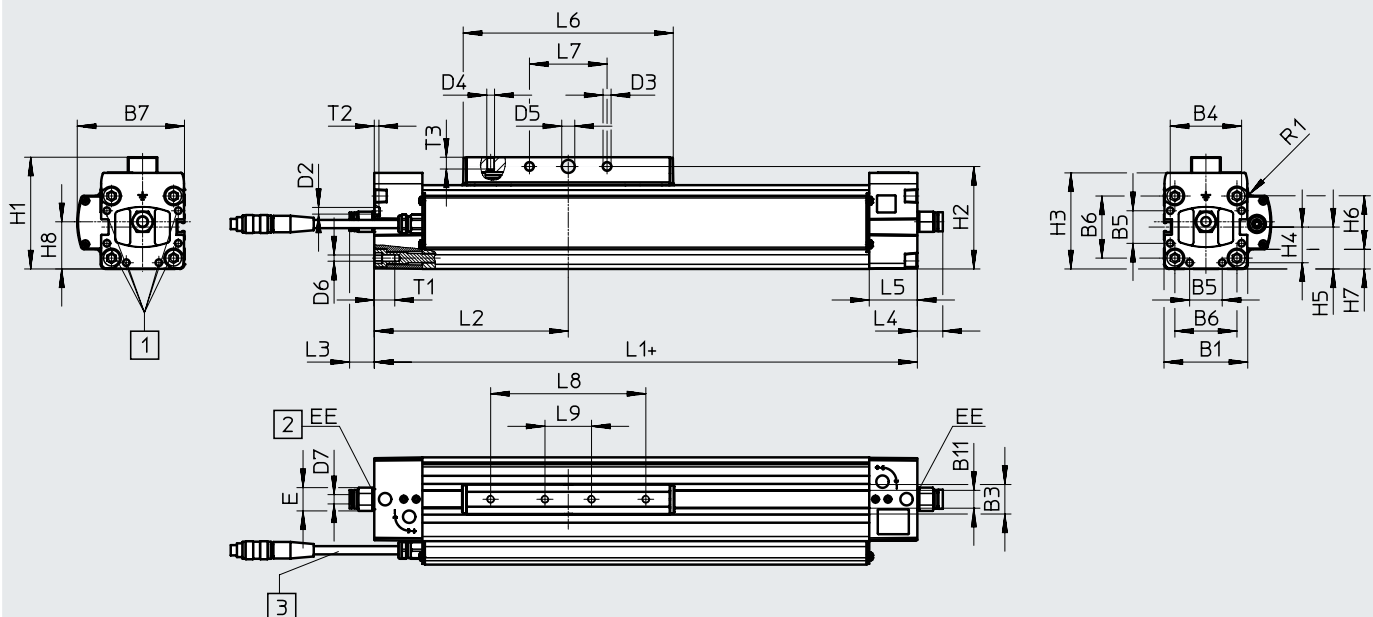

- + plus stroke length
- [1] Mounting hole for foot mounting
- [2] Connecting thread
- [3] Cable length 1500 mm

∅	B1	B3	B4	B5	B6	B7	B11	D2 ∅
[mm]	±0.4	±0.2				+0.4		
25	45	19	39.1	18	32.5	60.2	9.5	3.3
32	54	19	46	21	40	69.1	9.5	4.3
40	64	21	53	28	49	78.4	9.6	4.3
63	106	24	89	44	83	110.9	21.1	6.3

∅	D3 ∅	D4	D5 ∅ H7	D6	EE	H1	H2	H3
[mm]	±0.2							
25	5.2	M5	8	M4	G1/8	63	57	51
32	5.2	M5	8	M5	G1/8	72	66	61.8
40	6.5	M6	10	M5	G1/4	86	78	71.8
63	8.5	M8	12	M8	G3/8	131	122	115.2

∅	H4	H5	H6	H7	H8	R1	L1	L2
[mm]								
25	19.55	22.5	34.5	5.15	28.7	2.5	200	100
32	23	27	34.5	12.65	30.4	3.5	250	125
40	26.5	32	34.5	16.25	35.5	5	300	150
63	44.5	53	34.5	43.25	61	2	400	200

Data sheet

∅	L5	L6	L7	L8	L9	T1	T2	T3
[mm]			±0.1	±0.1	±0.1			
25	25	109	30	50	–	13	2	7.5
32	31	135	50	100	30	13.2	3	7.5
40	31	171	70	130	40	13.2	3	7.5
63	34	234	110	190	70	21.2	6	12.5

∅	Stroke	D7	E	L3	L4
[mm]	[mm]				
25	100 ... 160	6	15	15.9	16.4
	225 ... 2000	8	16	21.1	21.6
32	100	6	15	15.9	16.4
	160 ... 2000	8	16	21.1	21.6
40	100 ... 750	8	19	16.6	17.2
	850 ... 2000	10	19	23.6	24.3
63	100 ... 300	8	22	15.8	16.3
	360 ... 500	10	22	19.6	20.2
	600 ... 2000	12	24	25.7	26.3

Profile barrel

∅ 25

∅ 32

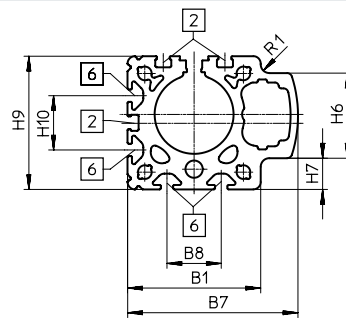
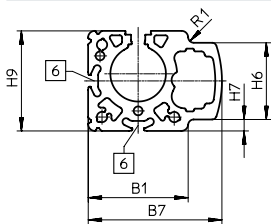

∅ 40

∅ 63

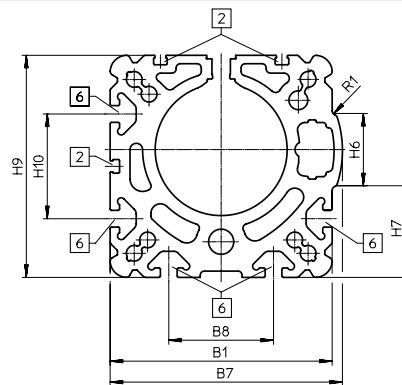
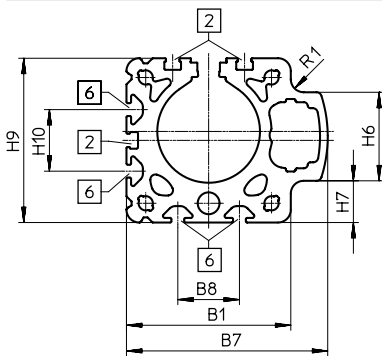

∅	B1	B7	B8	H6	H7	H9	H10	R1
[mm]	+0.4	+0.4				+0.4		
25	45	60.2	–	34.5	5.15	45	–	2.5
32	54	69.1	22	34.5	12.65	54	22	3.5
40	64	78.4	24	34.5	16.25	64	24	5
63	106	110.9	50	34.5	43.3	106	50	2

Ordering data – Modular product system

Ordering table							
Piston diameter	25	32	40	63	Condi- tions	Code	Enter code
Module no.	1315779	1344778	1463452	1572299			
Function	Linear drive with integrated displacement encoder					DDLI	DDLI
Piston diameter [mm]	25	32	40	63		-...	
Stroke [mm]	100, 160, 225, 300, 360, 450, 500, 600, 750, 850, 1000, 1250, 1500, 1750, 2000					-...	
Cushioning	Elastic cushioning rings/pads at both ends					-P	-P
Lubrication	Standard						
	Food-safe lubrication					-H1	
Foot mounting	None						
	1 set					-MF	
Profile mounting	None						
	1 ... 10					...MA	
Sensor slot cover	None						
	-	1 set (for the entire drive length and all slots)				NS	
Mounting slot cover	None						
	1 set (for the entire drive length and all slots)					NC	
Slot nut for the mounting slot	None						
	1 ... 50				[1]	...NM	
Moment compensator	None						
	Moment compensator coupling					T	
Adapter plate	None						
	FKP interface				[2]	AP	
Operating instructions	With operating instructions						
	Without operating instructions					DN	

[1] NM For size 25: Entry "1NM" = delivery quantity 4 pieces

[2] AP Only with moment compensator T

Accessories

Foot mounting HP (Order code: MF)

Material:
Galvanised steel

Note
Central supports MUP are additionally required for strokes above 400 mm
→ page 17
The foot mounting cannot be used when the bottom mounting position is used for the displacement encoder.

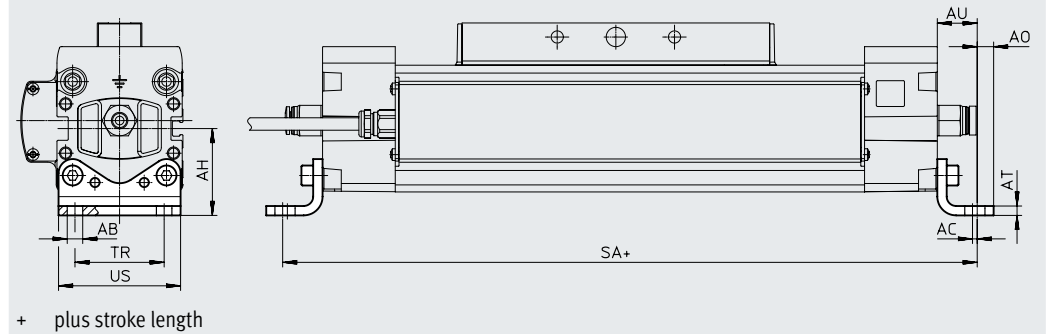
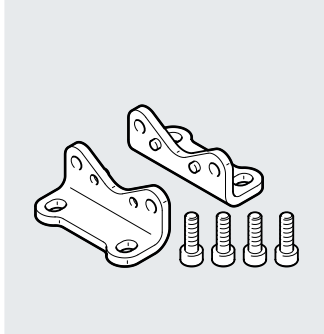

Dimensions and ordering data												
For \varnothing	AB	AC	AH	AO	AT	AU	SA	TR	US	Weight	Part no.	Type
[mm]	\varnothing									[g]		
25	5.5	2	29.5	6	3	13	226	32.5	44	61	150731	HP-25
32	6.6	2	37	7	4	17	284	38	52	117	150732	HP-32
40	6.6	2	46	8.5	5	17.5	335	45	62	188	150733	HP-40
63	11	3	69	13.5	6	28	456	75	102	305	150735	HP-63

Central support MUP (Order code: MA)

Material:
Anodised aluminium

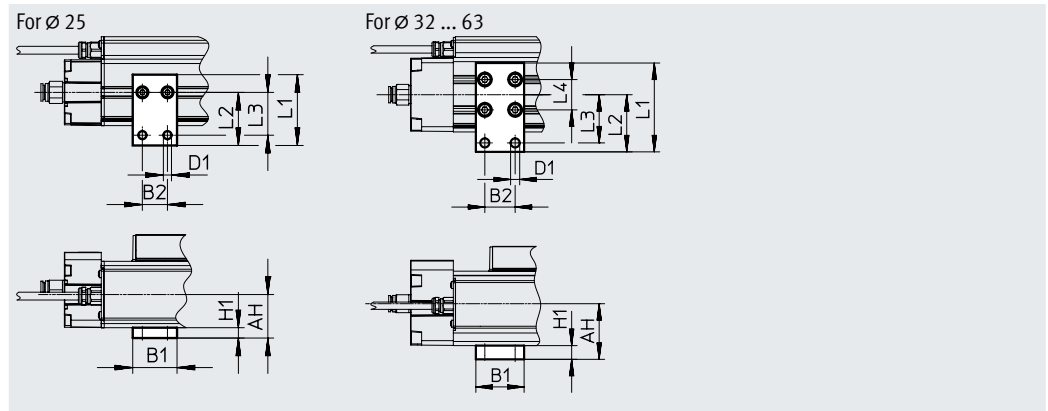
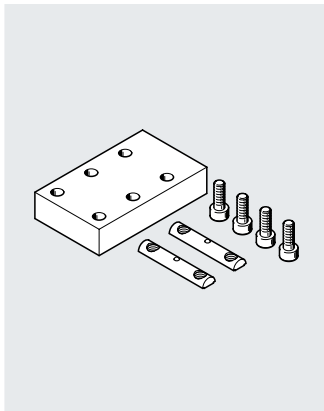

Dimensions and ordering data												
For \varnothing	AH	B1	B2	D1	H1	L1	L2	L3	L4	Weight	Part no.	Type
[mm]				\varnothing						[g]		
25	29.5	30	17	5.5	7	48	36	29	–	33	1711704	MUP-18/25-P
32	37	35	22	6.6	10	64.5	41.5	35	22	89	150737	MUP-32
40	46	35	22	6.6	14	75	47	40	24	126	150738	MUP-40
63	69	50	26	11	16	125	77	65	50	340	150800	MUP-63

Accessories

Moment compensator DARD
(Order code: T)

Material:
Galvanised steel

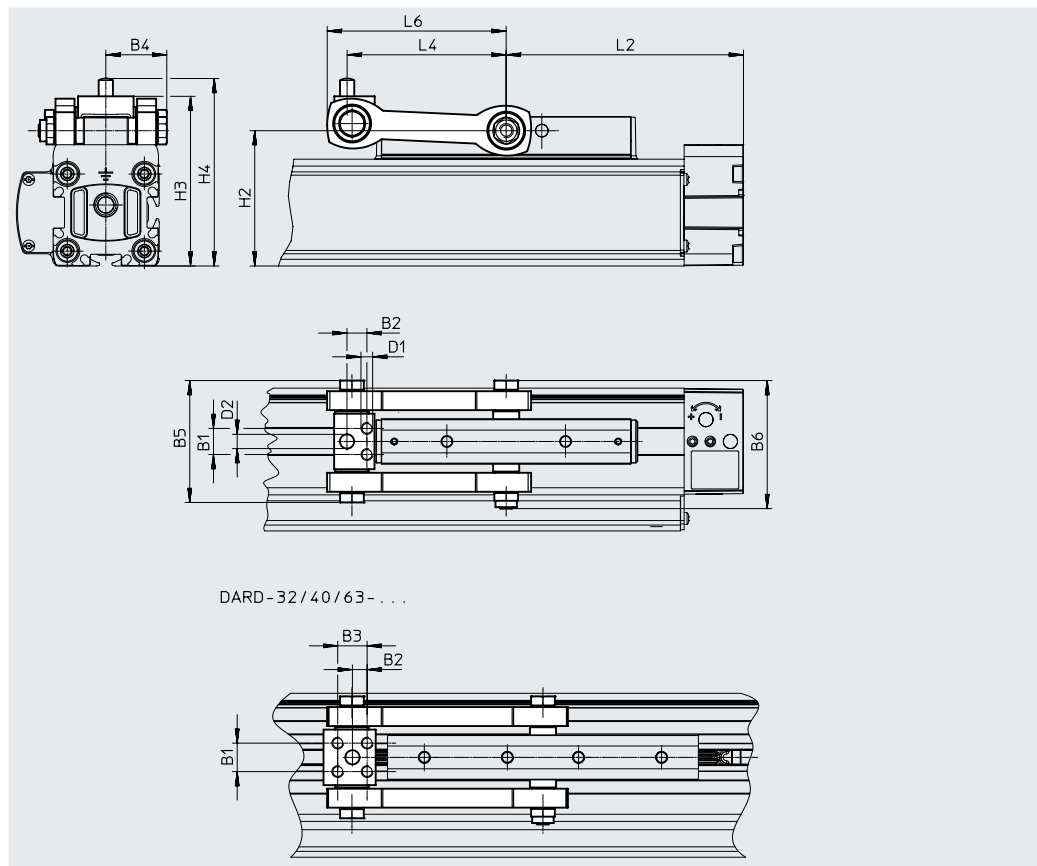

Dimensions and ordering data

For \varnothing [mm]	Max. offset between linear drive and external guide ¹⁾ [mm]	Max. permissible load in direction of force [N]	Ambient temperature [°C]	Weight [g]
25	± 2.5	800	-10 ... +60	240
32	± 2.5	1300	-10 ... +60	275
40	± 2.5	2000	-10 ... +60	580
63	± 4	5000	-10 ... +60	1000

1) Laterally and vertically.

For \varnothing [mm]	B1	B2	B3	B4	B5	B6	D1 \varnothing	D2 \varnothing	H2
25	11	8.4	-	25.7 \pm 2.5	51.4	54	M5x17	6	57
32	12	6.2	12.4	25.7 \pm 2.5	51.4	54	M5x13	6	66
40	18	11	17	36 \pm 2.5	72	75.3	M6x16	8	78
63	26	12.6	19	44 \pm 4	88	96.4	M8x18	10	122

For \varnothing [mm]	H3	H4	L2	L4	L6 max.	Part no.	Type
25	71.5 \pm 2.5	79 \pm 2.5	100	67.1	75.5	2349275	DARD-L1-25-M
32	80.5 \pm 2.5	88 \pm 2.5	125	80.3	91	2349276	DARD-L1-32-M
40	94.5 \pm 2.5	104.5 \pm 2.5	150	104	117	2349277	DARD-L1-40-M
63	142 \pm 4	152 \pm 4	200	138	153	2349279	DARD-L1-63-M

Accessories

Adapter plate DAMF
(Order code: AP)

Material:
Galvanised steel

The adapter plate DAMF has the same interface as the moment compensator FKP for linear drive DGP.

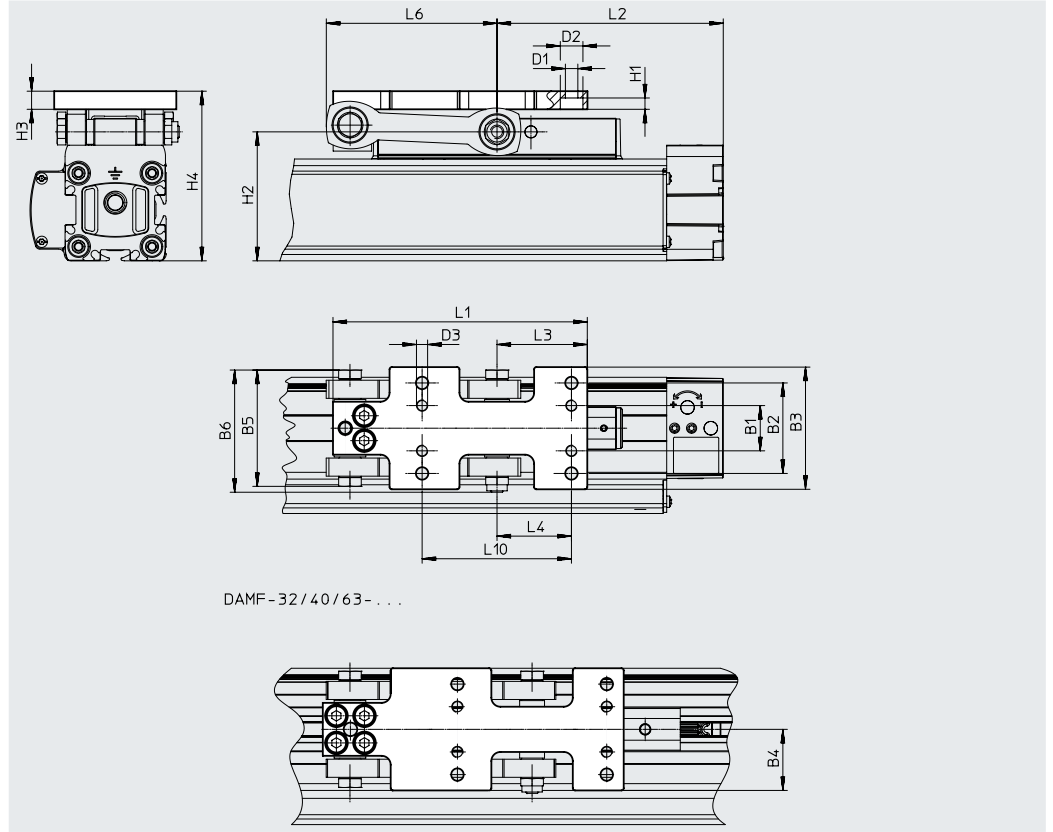

Dimensions and ordering data

For \varnothing	B1	B2	B3	B4	B5	B6	D1 \varnothing	D2 \varnothing	D3	H1	H2	H3
[mm]												
25	20	40	54	27±2.5	51.4	54	5.5	10	M5	5	57	8
32	20	40	54	27±2.5	51.4	54	5.5	10	M5	5	66	8
40	24	44	58	29±2.5	72	75.3	6.6	11	M6	6	78	10
63	23	51	71	35.5±4	88.1	96.4	9	15	M8	8	122	10

For \varnothing	H4	L1	L2	L3	L4	L6	L10	Weight	Part no.	Type
[mm]						max.				
25	75±2.5	112.4	100	40	33	75.5	66	265	2349282	DAMF-25-FKP
32	84±2.5	133	125	40.5	33	91	66	308	2349283	DAMF-32-FKP
40	99±2.5	162	150	45	38	117	76	593	2349284	DAMF-40-FKP
63	146±4	214	200	61	51	153	102	1042	2349286	DAMF-63-FKP

Accessories

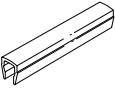
Ordering data		For ø	Description	Order code	Part no.	Type	PU ¹⁾	
Slot nut ABAN, NST Data sheets → Internet: hmbn								
	25	For mounting slot	NM	8003032	ABAN-1M4-5		4	
	32, 40				NST-5-M5		1	
	63				NST-8-M6			
Slot cover ABP Data sheets → Internet: abp								
	25	For mounting slot	NC	563360	ABP-5-S1		2	
	32, 40	Each 0.5 m			151681			ABP-5
	63				151682			ABP-8
	25, 32, 40, 63	For sensor slot Each 0.5 m	NS	563360	ABP-5-S1	2		

1) Packaging unit

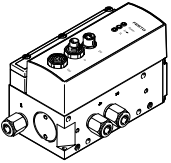
Ordering data – Proportional directional control valves		For ø	Stroke	Proportional directional control valve	
		[mm]	[mm]	Data sheets → Internet: vpwp	
				Part no.	Type
For applications with axis controller CPX-CMAX					
	25	100 ... 160	550170	VPWP-4-L-5-Q6-10-E-...	
		225 ... 600	550170	VPWP-4-L-5-Q8-10-E-...	
		750 ... 2000	550171	VPWP-6-L-5-Q8-10-E-...	
	32	100	550170	VPWP-4-L-5-Q6-10-E-...	
		160 ... 360	550170	VPWP-4-L-5-Q8-10-E-...	
		450 ... 2000	550171	VPWP-6-L-5-Q8-10-E-...	
	40	100 ... 300	550170	VPWP-4-L-5-Q8-10-E-...	
		360 ... 750	550171	VPWP-6-L-5-Q8-10-E-...	
		850 ... 2000	550172	VPWP-8-L-5-Q10-10-E-...	
	63	100 ... 300	550171	VPWP-6-L-5-Q8-10-E-...	
		360 ... 450	550172	VPWP-8-L-5-Q10-10-E-...	
		500 ... 750	550172	VPWP-8-L-5-Q-10-E-... ¹⁾	
		850 ... 2000	1552544	VPWP-10-L-5-Q-10-E-G-EX1 ¹⁾	

1) Push-in fittings for a tubing O.D. of 12 mm must be used for these stroke ranges.

Accessories

Ordering data – Proportional directional control valves

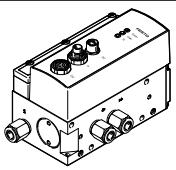
	For \varnothing	Stroke	Proportional directional control valve	
	[mm]	[mm]	Part no.	Type
	For applications with Soft Stop end-position controller CPX-CMPX, horizontal			
	25	100 ... 160	550170	VPWP-4-L-5-Q6-10-E...
		225 ... 300	550170	VPWP-4-L-5-Q8-10-E...
		360 ... 2000	550171	VPWP-6-L-5-Q8-10-E...
	32	100	550170	VPWP-4-L-5-Q6-10-E...
		160 ... 1000	550171	VPWP-6-L-5-Q8-10-E...
		1250 ... 2000	550172	VPWP-8-L-5-Q-10-E... ¹⁾
	40	100 ... 500	550171	VPWP-6-L-5-Q8-10-E...
		600 ... 750	550172	VPWP-8-L-5-Q-10-E... ¹⁾
		850 ... 2000	550172	VPWP-8-L-5-Q10-10-E...
	63	100 ... 300	550171	VPWP-6-L-5-Q8-10-E...
		360 ... 400	550172	VPWP-8-L-5-Q10-10-E...
		450	1552544	VPWP-10-L-5-Q-10-E-G-EX1 ²⁾
		500 ... 2000	1552544	VPWP-10-L-5-Q-10-E-G-EX1 ³⁾

- 1) Push-in fittings for a tubing O.D. of 8 mm must be used for these stroke ranges.
 2) Push-in fittings for a tubing O.D. of 10 mm must be used for this stroke range.
 3) Push-in fittings for a tubing O.D. of 12 mm must be used for these stroke ranges.

Ordering data – Proportional directional control valves

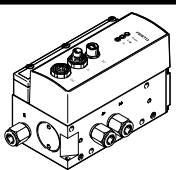
	For \varnothing	Stroke	Proportional directional control valve	
	[mm]	[mm]	Part no.	Type
	For applications with Soft Stop end-position controller CPX-CMPX, vertical			
	25	100 ... 160	550170	VPWP-4-L-5-Q6-10-E...
		225 ... 750	550170	VPWP-4-L-5-Q8-10-E...
		850 ... 2000	550171	VPWP-6-L-5-Q8-10-E...
	32	100	550170	VPWP-4-L-5-Q6-10-E...
		160 ... 300	550170	VPWP-4-L-5-Q8-10-E...
		360 ... 1750	550171	VPWP-6-L-5-Q8-10-E...
		2000	550172	VPWP-8-L-5-Q-10-E... ¹⁾
	40	100 ... 225	550170	VPWP-4-L-5-Q8-10-E...
		300 ... 750	550171	VPWP-6-L-5-Q8-10-E...
		850 ... 1000	550171	VPWP-6-L-5-Q-10-E... ²⁾
		1250 ... 2000	550172	VPWP-8-L-5-Q10-10-E...
	63	100 ... 225	550170	VPWP-4-L-5-Q8-10-E...
		300	550171	VPWP-6-L-5-Q8-10-E...
		360 ... 450	550172	VPWP-8-L-5-Q10-10-E...
500 ... 2000		1552544	VPWP-10-L-5-Q-10-E-G-EX1 ³⁾	

- 1) Push-in fittings for a tubing O.D. of 8 mm must be used for these stroke ranges.
 2) Push-in fittings for a tubing O.D. of 10 mm must be used for these stroke ranges.
 3) Push-in fittings for a tubing O.D. of 12 mm must be used for these stroke ranges.

Accessories

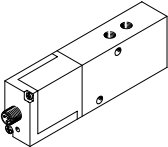
Ordering data – Proportional directional control valves				
	For \varnothing	Stroke	Proportional directional control valve	
	[mm]	[mm]	Part no.	Type
	For applications with Soft Stop end-position controller SPC11-MTS-AIF-2, horizontal			
	25	100 ... 160	151692	MPYE-5-1/8-LF-010-B
		225 ... 300	151692	MPYE-5-1/8-LF-010-B
		360 ... 2000	151693	MPYE-5-1/8-HF-010-B
	32	100	151692	MPYE-5-1/8-LF-010-B
		160 ... 1000	151693	MPYE-5-1/8-HF-010-B
		1250 ... 2000	151694	MPYE-5-1/4-010-B
	40	100 ... 500	151693	MPYE-5-1/8-HF-010-B
		600 ... 750	151694	MPYE-5-1/4-010-B
		850 ... 2000	151694	MPYE-5-1/4-010-B
	63	100 ... 300	151693	MPYE-5-1/8-HF-010-B
		360 ... 400	151694	MPYE-5-1/4-010-B
		450 ... 2000	151695	MPYE-5-3/8-010-B

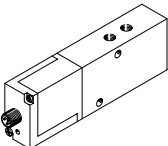
Ordering data – Proportional directional control valves				
	For \varnothing	Stroke	Proportional directional control valve	
	[mm]	[mm]	Part no.	Type
	For applications with Soft Stop end-position controller SPC11-MTS-AIF-2, vertical			
	25	100 ... 160	151692	MPYE-5-1/8-LF-010-B
		225 ... 750	151692	MPYE-5-1/8-LF-010-B
		850 ... 2000	151693	MPYE-5-1/8-HF-010-B
	32	100	151692	MPYE-5-1/8-LF-010-B
		160 ... 300	151692	MPYE-5-1/8-LF-010-B
		360 ... 1750	151693	MPYE-5-1/8-HF-010-B
	40	2000	151694	MPYE-5-1/8-010-B
		100 ... 225	151692	MPYE-5-1/8-LF-010-B
		300 ... 750	151693	MPYE-5-1/8-HF-010-B
	63	850 ... 1000	151693	MPYE-5-1/8-HF-010-B
		1250 ... 2000	151694	MPYE-5-1/4-010-B
		100 ... 225	151692	MPYE-5-1/8-LF-010-B
	300	300	151693	MPYE-5-1/8-HF-010-B
		360 ... 450	151694	MPYE-5-1/4-010-B
500 ... 2000		151695	MPYE-5-3/8-010-B	

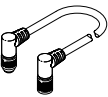
Ordering data – Connecting cables				
	Description	Cable length [m]	Part no.	Type
		Connection between axis controller CPX-CMAX/end-position controller CPX-CMPX and proportional directional control valve VPWP		
Angled plug and angled socket		0.25	540327	KVI-CP-3-WS-WD-0.25
		0.5	540328	KVI-CP-3-WS-WD-0.5
		2	540329	KVI-CP-3-WS-WD-2
		5	540330	KVI-CP-3-WS-WD-5
		8	540331	KVI-CP-3-WS-WD-8
Straight plug and straight socket		2	540332	KVI-CP-3-GS-GD-2
		5	540333	KVI-CP-3-GS-GD-5
		8	540334	KVI-CP-3-GS-GD-8