

Three-dimensional gantries EXCL

FESTO

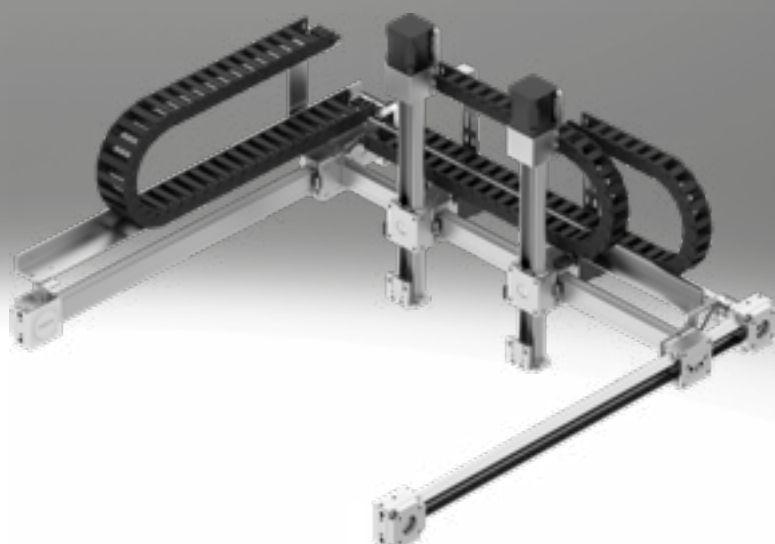

Key features

At a glance

The three-dimensional gantry EXCL is ideal, for example, for analytical processes where sample vials are to be opened and liquid samples pipetted in the same three-dimensional gantry. The optional second Z-axis enables two front units to move independently of each other, such as the rotary gripper module EHMD and the smart pipette DHOP.

EXCL is a three-dimensional gantry for installation in devices such as analytical table top units and is optimised for life sciences applications. The working area (X,Y) can be configured up to 1000 mm x 700 mm in 1-mm steps. The stroke of each of the Z-axes can be selected separately from 50, 100, 150 and 200 mm. Configuration as a planar surface gantry X,Y without Z-axes is also possible.

Application examples with further Festo components

- Automated sample preparation for the analysis of sample vials (e.g. clinical analysis of patient samples or material analysis of samples for quality assurance)
 - using the rotary gripper module EHMD
- Picking up sample vessels from a rack and rotating them
 - using the rotary gripper module EHMD
- Taking a liquid sample and transferring it to a microwell plate for further analysis
 - using the smart pipette DHOP or pipette head DHOE
- Dispensing reagents into the microwell plate
 - using the dispense head VTOE
- Implementing rinsing procedures in the ELISA process
 - using the dispense head VTOI

Operating mode

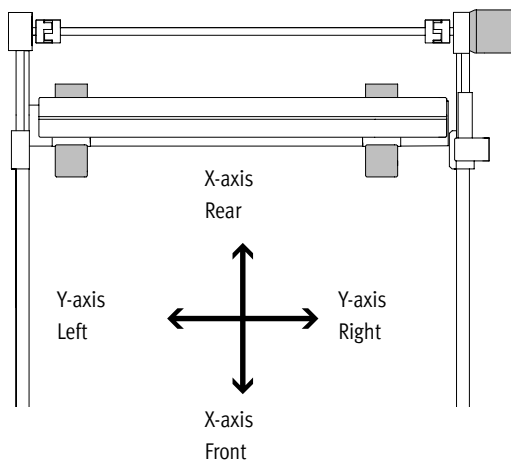

Key features

Variants

[Z1...L] X-axis motor on left and 1 Z-axis

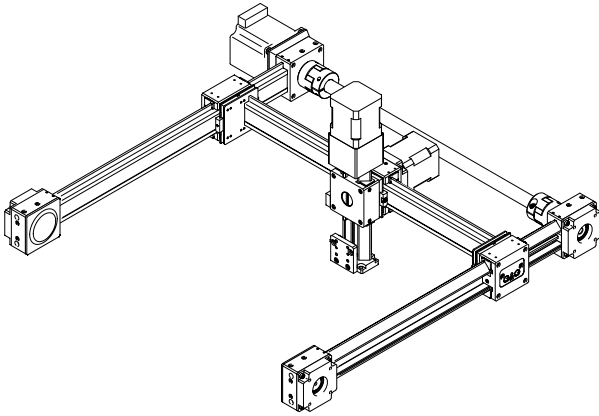

[Z1...R] X-axis motor on right and 1 Z-axis

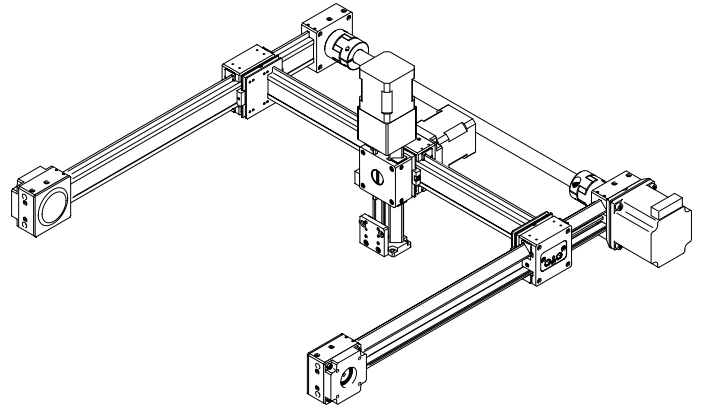

[Z2...L] X-axis motor on left and 2 Z-axes

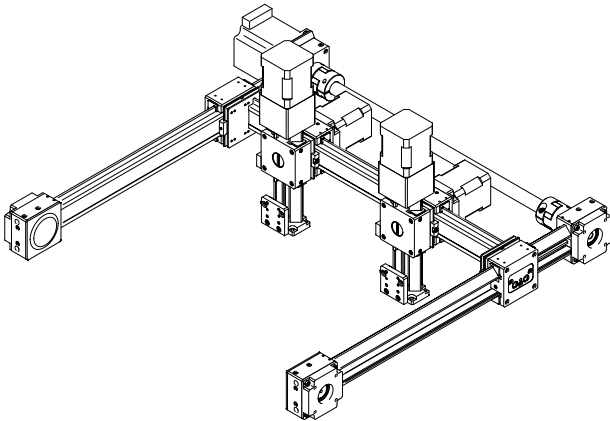

[Z2...R] X-axis motor on right and 2 Z-axes

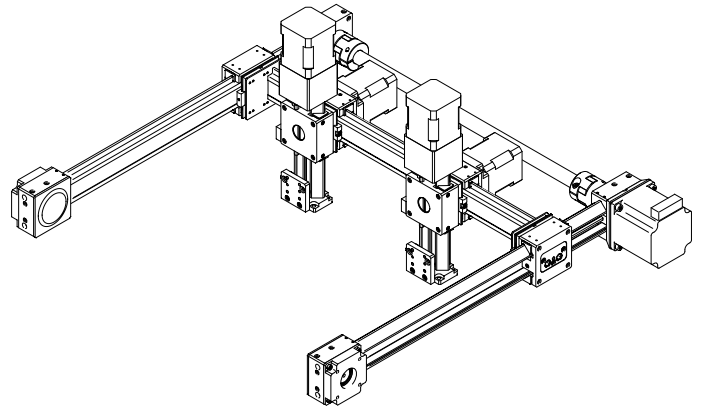

Key features

Variants

[YS1...L] X-axis motor on left and 1 slide

[YS1...R] X-axis motor on right and 1 slide

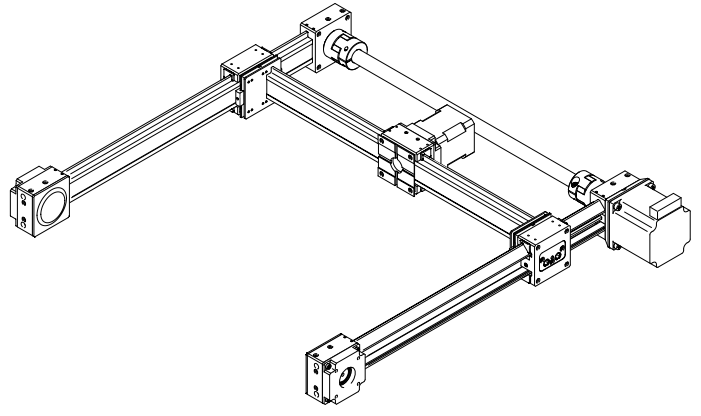
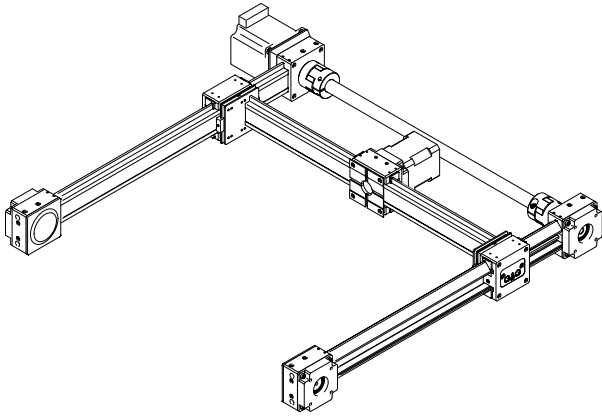

[YS2...L] X-axis motor on left and 2 slide

[YS2...R] X-axis motor on right and 2 slide

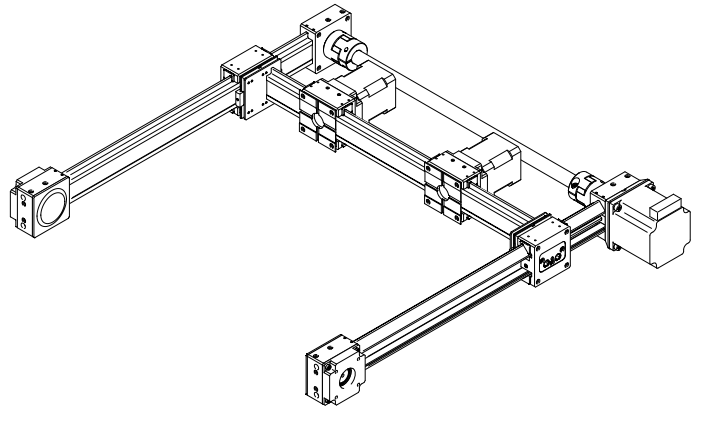
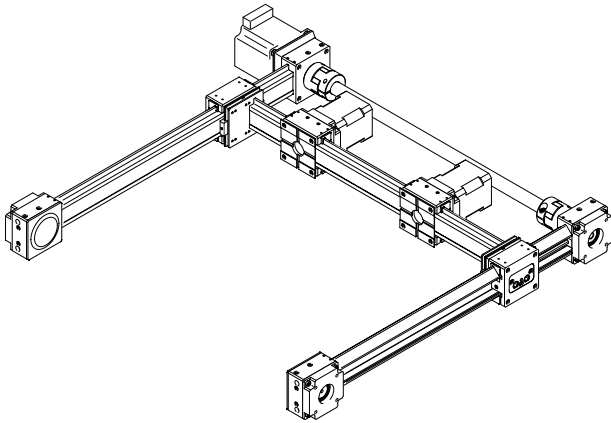

Type codes

001	Series	
EXCL	Three-dimensional gantry	
002	Size	
15	15	
003	Stroke of the X-axis [mm]	
200	200	
400	400	
1000	1000	
004	Stroke of the Y-axis [mm]	
200	200	
300	300	
700	700	
005	Number of Z-axes	
	No Z-axis	
Z1	One Z-axis	
Z2	Two Z-axes	
006	Version of the Y-axis	
	Standard	
YS1	1 slide	
YS2	2 slides	
007	Stroke of the Z-axis 1	
	No Z-axis	
50	50 mm	
100	100 mm	
150	150 mm	
200	200 mm	

008	Stroke of the Z-axis 2	
	No Z-axis	
50	50 mm	
100	100 mm	
150	150 mm	
200	200 mm	
009	Guide	
GF	Plain bearing	
010	Motor type	
ST	Stepper motor ST	
011	Motor attachment position	
L	Left	
R	Right	
012	Cable length [m]	
0.2	0.2	
1	1	
2	2	
013	Energy chain	
EK	With	
014	Controller	
	None	
M6	For six motors	
015	Position sensing	
AN	With integrated zero position sensing	

Peripherals overview

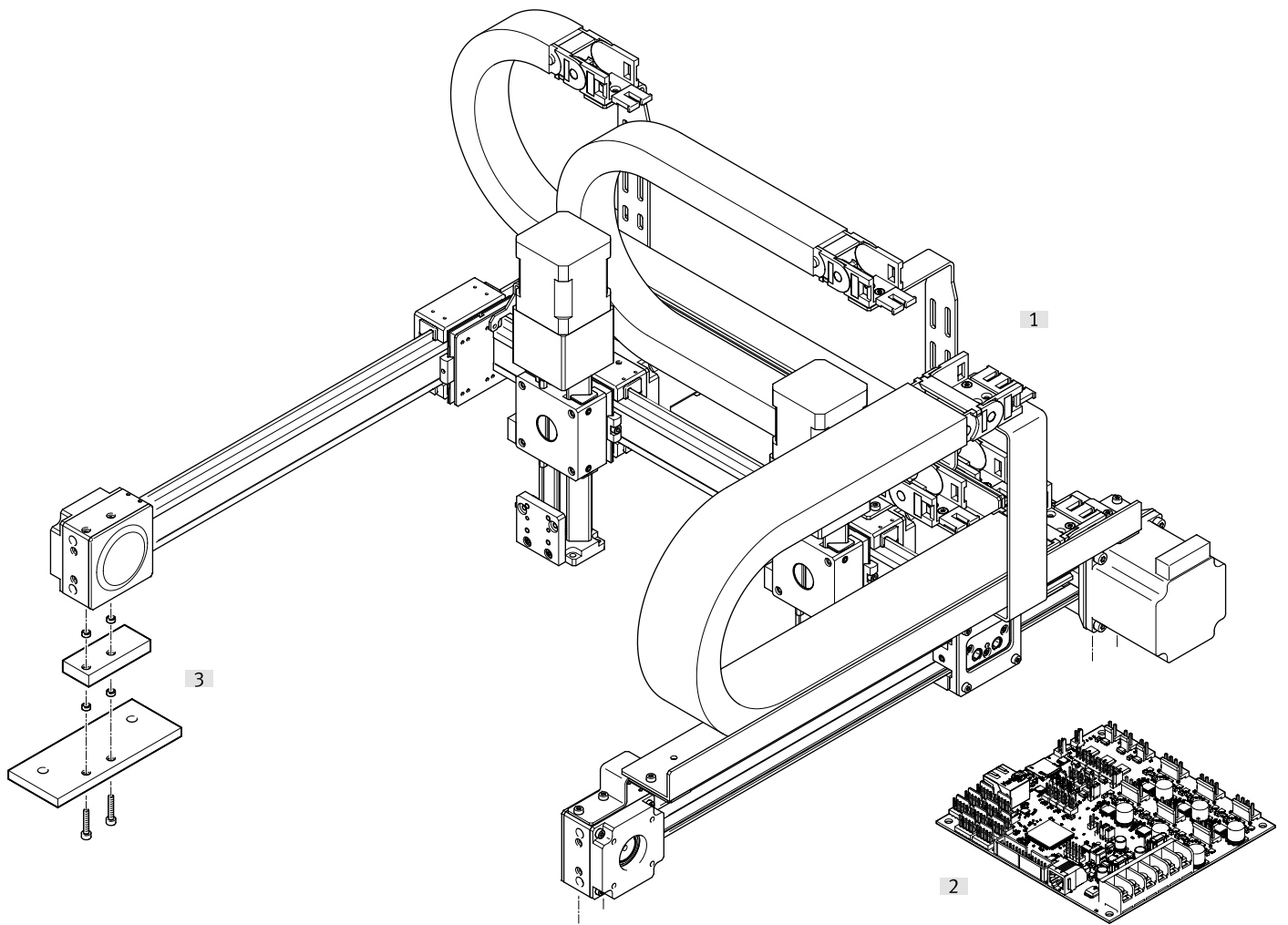

Accessories		
Type	Description	→ Page/Internet
[1] Three-dimensional gantry EXCL	Electric	7
[2] Servo drive CMXL	PCB with 6-axis motion controller for direction integration into the device	15
[3] Adapter kit EHAM	<ul style="list-style-type: none"> • For mounting the gantry via the end cap (shown on one side by way of example) • 4 included in the scope of delivery 	15

 **Note**

The stepper motors, motor cables and connecting cables to the reference switches are included in the scope of delivery of the three-dimensional gantry. The servo drive is optional.

Datasheet



General technical data		
Design	Three-dimensional gantry system	
Guide	Plain-bearing guide	
Stroke of the		
X-axis	[mm]	200 ... 1000
Y-axis	[mm]	200 ... 700
Z-axis	[mm]	50, 100, 150, 200
Min. stroke limit	[mm]	50
Max. stroke limit	[mm]	1000
Rated load ¹⁾	[kg]	1.5 (with one Z-axis)
	[kg]	2 (in total, with 2 Z-axes)
Max. process force ²⁾	[N]	15
Motor holding torque	[Nm]	0.5 ... 1.4
Rated voltage		
X-axis	[V]	1.68
Y-axis	[V]	3.2
Z-axis	[V]	3.2
Rated current		
X-axis	[A]	4.2
Y-axis	[A]	2
Z-axis	[A]	2
Max. acceleration		
X-axis	[m/s ²]	1
Y-axis	[m/s ²]	1
Z-axis	[m/s ²]	0.2
Max. speed		
X-axis	[m/s]	0.4
Y-axis ³⁾	[m/s]	0.5
Z-axis	[m/s]	0.07
Max. search speed velocity		
X-axis	[m/s]	0.03
Y-axis	[m/s]	0.03
Z-axis	[m/s]	0.015
Max. creep speed		
X-axis	[m/s]	0.003
Y-axis	[m/s]	0.003
Z-axis	[m/s]	0.003
Repetition accuracy	[mm]	±0.1
Mounting position	Horizontal	
Type of mounting	With female thread M3	

1) Rated load = tool load (attachment components) + payload

2) Perpendicular to the working plane, at standstill

3) Tested at: v=0.4m/s and two Z-axes: Additional weight: Z1=0.5kg and Z2=1.5kg

Datasheet

Operating and environmental conditions		
Degree of protection		IP10
Ambient temperature ¹⁾	[°C]	+10 ... +40
Storage temperature	[°C]	-10 ... +60
Relative humidity	[%]	0 ... 90 (non-condensing)
Noise level	[dB(A)]	79.2
Duty cycle	[%]	100
Vibration resistant		Transport inspection to FN 942017-4 and EN 60068-2-6
Shock resistance		Shock test with severity level 1 to FN 942017-5 and EN 60068-2-27
KC		KC EMC
CE marking (see declaration of conformity) ²⁾		To EU EMC Directive
UKCA marking (see declaration of conformity) ²⁾		To UK EMC regulations

1) Note operating range of proximity sensors and motors

2) More information www.festo.com/catalogue/excl → Support/Downloads

Materials	
X/Y/Z profile	Aluminium
Housing	Aluminium
Guide	POM
X-axis drive pinion	Aluminium
Y-axis drive pinion	POM
Clamping pinion	Aluminium
Toothed belt	Polychloroprene with glass cord
Gear rack	Aluminium
LABS (PWIS) conformity	VDMA24364 zone III
Note on materials	RoHS-compliant

Toothed belt for X-axis		
Pitch	[mm]	2
Width	[mm]	8

Feed constant		
X-axis	[mm/rev]	64
Y-axis	[mm/rev]	37.7
Z-axis	[mm/rev]	5

Weight [kg]	
Product weight (without rated load and controllers)	
Stroke: x = 200 mm; Y = 300 mm; 1x z = 50 mm	5.45
Stroke: x = 400 mm; Y = 700 mm; 2x z = 200 mm	9.12
Base weight	
With 1 slide	3.68
With 2 slides	4.66
Additional weight per 50 mm stroke	
X-axis	0.14
Y-axis with 1 slide	0.09
Y-axis with 2 slides	0.13
Weight	
Adapter kit EHAM-...	0.35

Dimensions

Dimensions

Download CAD data → www.festo.com

EXCL-15-...-Z1-...-L

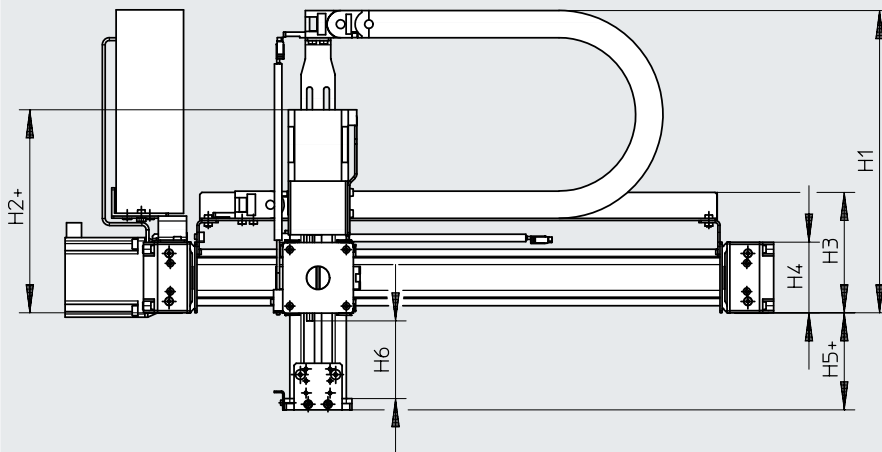
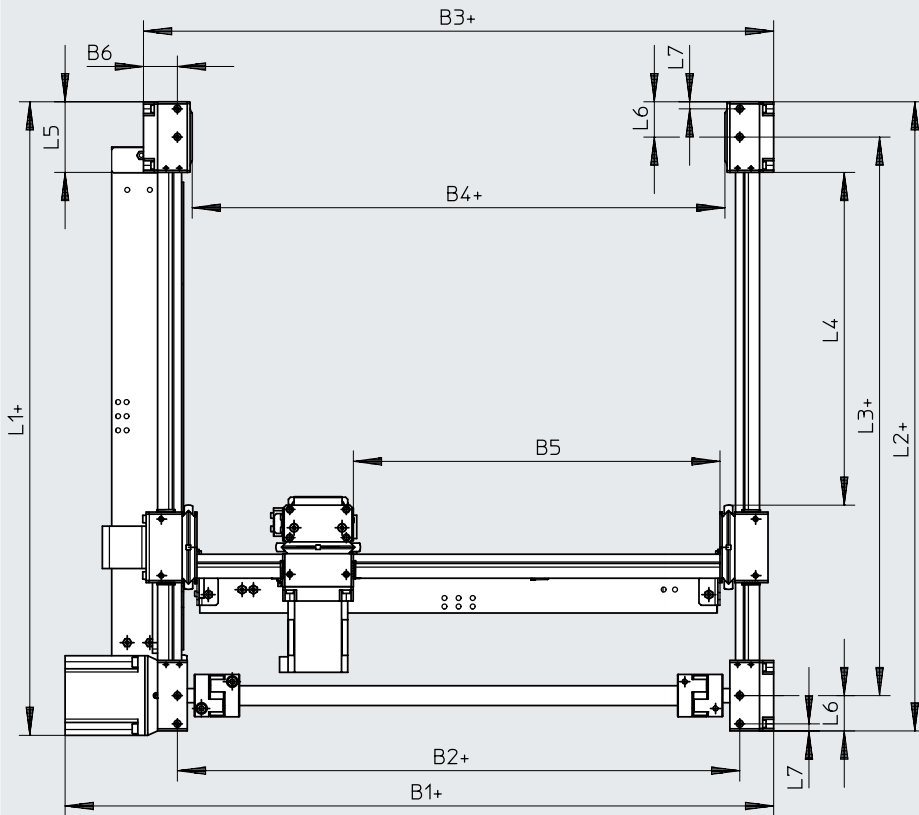

+ = plus stroke length

Type	B1	B2	B3	B4	B5	B6	H1	H2	H3	H4
[mm]										
EXCL-15	202	98.3	147	77	200 ... 700	24	214	144	85.3	50

Type	H5	H6	L1	L2	L3	L4	L5	L6	L7
[mm]									
EXCL-15	14	50 ... 200	219	215.5	165.5	200 ... 1000	50	25	5

Dimensions

Dimensions

Download CAD data → www.festo.com

EXCL-15-...Z2-...-L

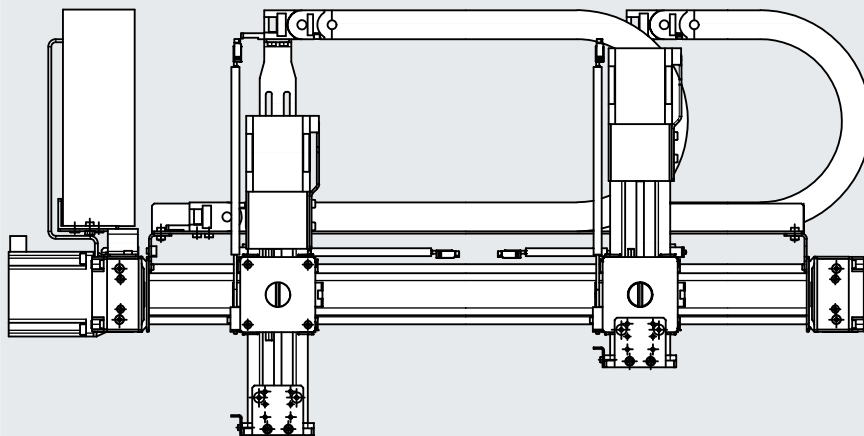
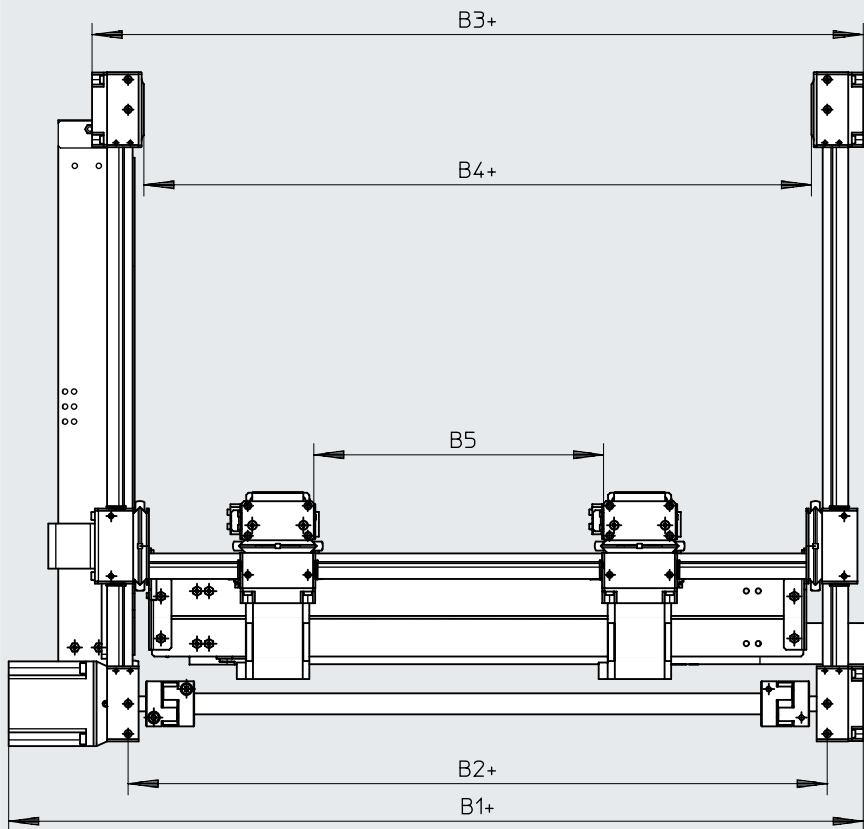

+ = plus stroke length

Type	B1	B2	B3	B4	B5
[mm]					
EXCL-15	269	165.8	214	144	200 ... 700

Dimensions

Dimensions

Download CAD data → www.festo.com

EXCL-15-...-Z2-...-R

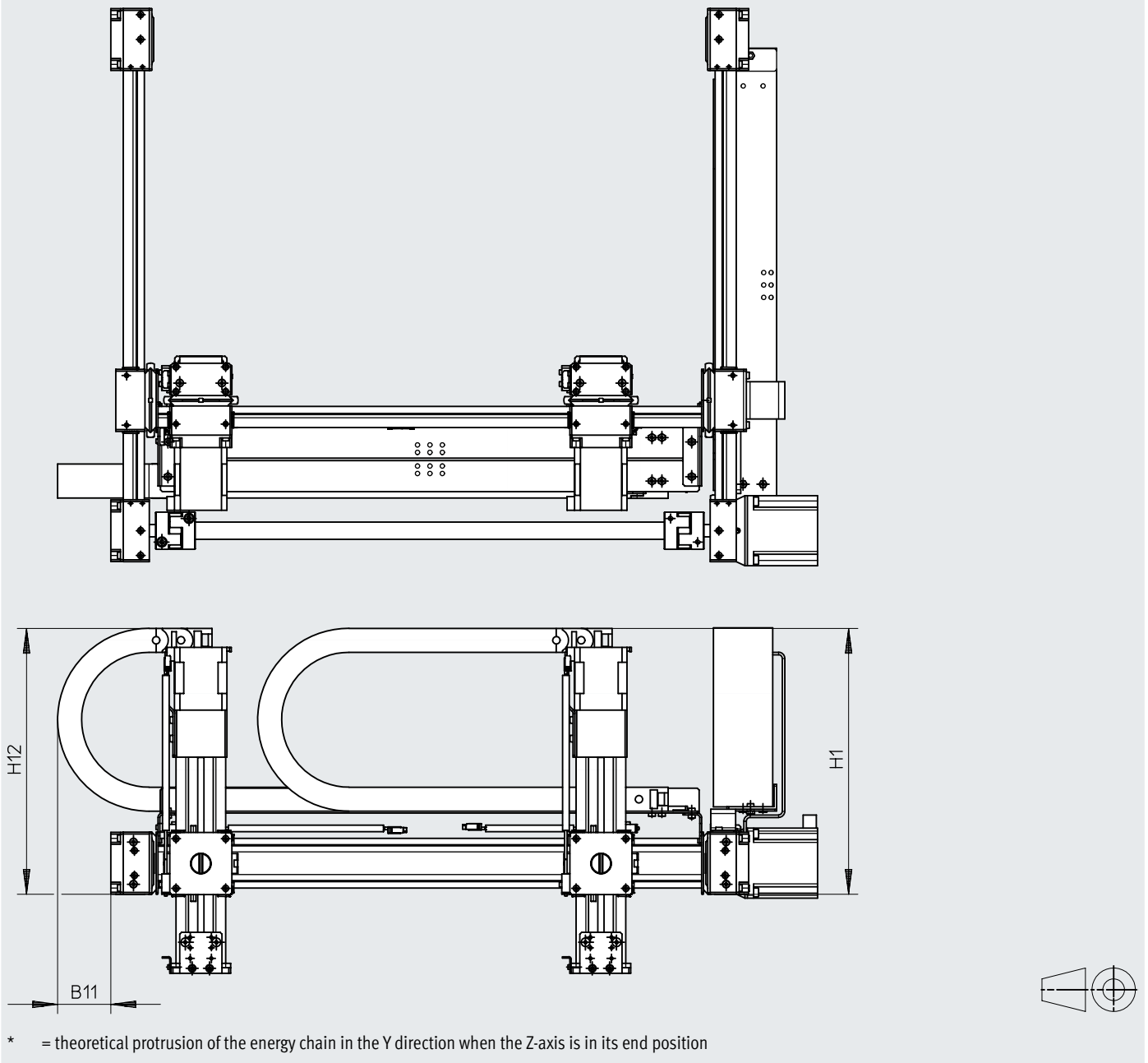

Type	B11*	H1	H12
[mm]			
EXCL-15	43	214	214

Dimensions

Dimensions

Download CAD data → www.festo.com

EXCL-15-...-Z... (interface)

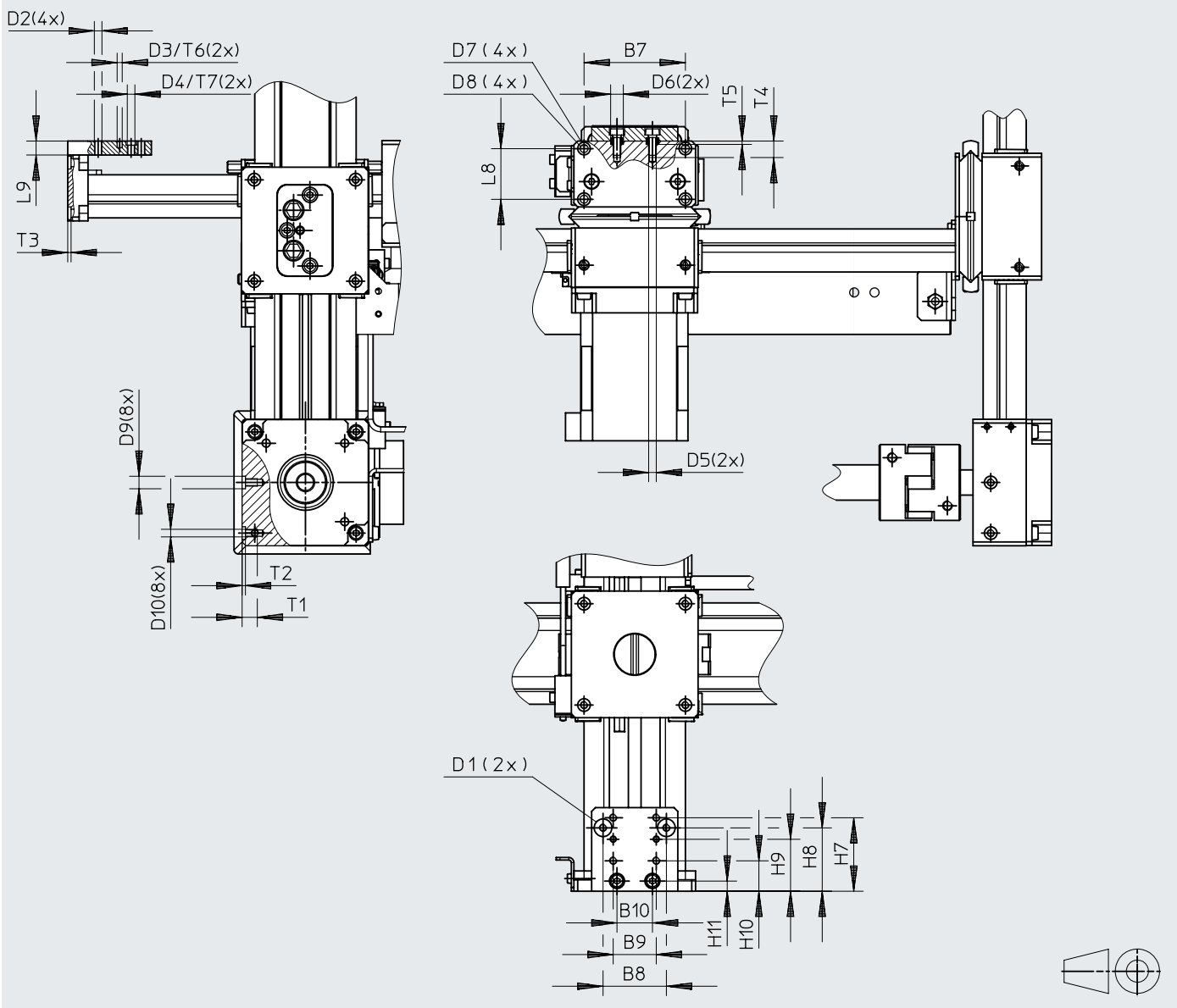

Type	B7	B8	B9	B10	D1	D2	D3	D4	D5	D6	D7	D8	D9	D10
[mm]					∅ H7		∅ H8			∅ H7	∅ H7	∅	∅ H7	
EXCL-15	40	25	17	14	7	M3	2	M3	M3	5	5	3.4	5	M3

Type	H7	H8	H9	H10	H11	L8	L9	T1	T2	T3	T4	T5	T6	T7
[mm]														
EXCL-15	29	25	20.5	12	4	20	5.5	6	1.3	1.3	6.5	1.3	2.6	1.6

Dimensions

Dimensions

Download CAD data → www.festo.com

EXCL-15-...-YS... (interface)

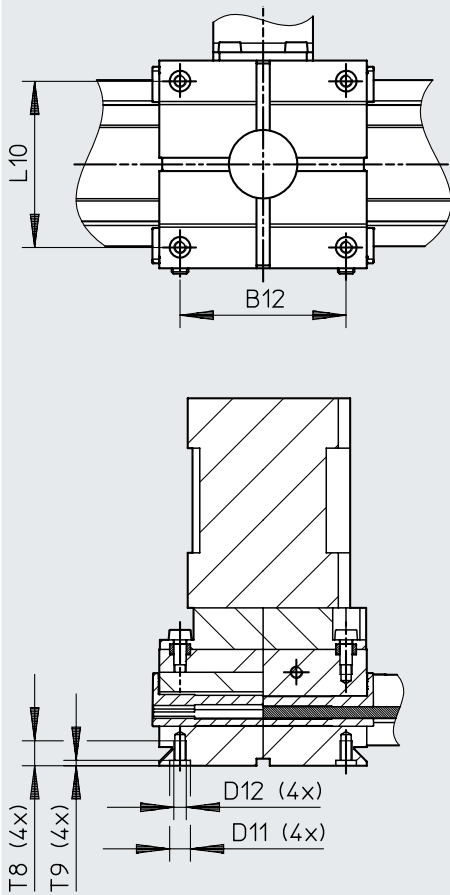

Type	B12	D11 Ø	D12	L10	T8	T9
[mm]	±0.05	H7		±0.05	max.	
EXCL-15	40	5	M3	40	6	1.3

Ordering data – Modular product system

Ordering table		Size	Conditions	Code	Enter code
Size		15			
Module no.		8159775			
Product type		EXCL series L		EXCL	EXCL
Size		15		-15	15
Stroke of the X-axis	[mm]	200 ... 1000		-...	
Stroke of the Y-axis	[mm]	200 ... 700		-...	
Number of Z-axes		No Z-axis			
		1 Z-axis		-Z1	
		2 Z-axes		-Z2	
Y-axis version		Standard			
		1 slide	[1]	YS1	
		2 slides	[1]	YS2	
Stroke of the Z-axis 1		No Z-axis			
	[mm]	50	[2]	-50	
	[mm]	100	[2]	-100	
	[mm]	150	[2]	-150	
	[mm]	200	[2]	-200	
Stroke of the Z-axis 2		No Z-axis			
	[mm]	50	[3]	-50	
	[mm]	100	[3]	-100	
	[mm]	150	[3]	-150	
	[mm]	200	[3]	-200	
Guide		Plain-bearing guide		-GF	-GF
Motor type		Stepper motor ST		-ST	-ST
Motor attachment position		Left		-L	
		Right		-R	
Cable length ¹⁾		0.2 ... 2 m		-...	
Energy chain		with		-EK	-EK
Controller		None			
		For 6 motors		-M6	
Position sensing		With integrated zero position sensing		-AN	

[1] **YS1, YS2** Mandatory with number of Z-axes "no axis"; Not with number of Z-axes "1 axis"; Not with number of Z-axes "2 axes"
 [2] **50, 100, 150, 200** Mandatory with number of Z-axes "1 axis"; Mandatory with number of Z-axes "2 axes"
 [3] **50, 100, 150, 200** Mandatory with number of Z-axes "2 axes"

Selection of cable length

1) The cable length can be selected using the modular product system. This specification relates to the output of the energy chain at the X-axis (dimension L) and describes the minimum length by which the cables protrude.

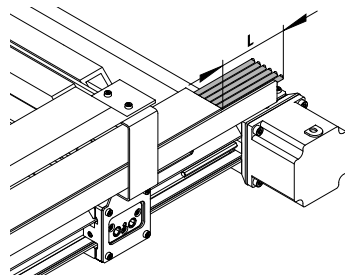

Ordering data – Three-dimensional gantry						
	Stroke of the X-axis	Stroke of the Y-axis	Number of Z-axes	Stroke of the Z-axes	Part no.	Type
	200	300	1	100	8184925	EXCL-15-200-300-Z1-100-GF-ST-R-1-EK-M6-AN
	400	700	2	200	8184926	EXCL-15-400-700-Z2-200-200-GF-ST-R-1-EK-M6-AN

Accessories

Adapter kit EHAM

Material:
 Plates: Anodised aluminium
 Screws: Galvanised steel
 Centring sleeves: Stainless steel
 RoHS-compliant

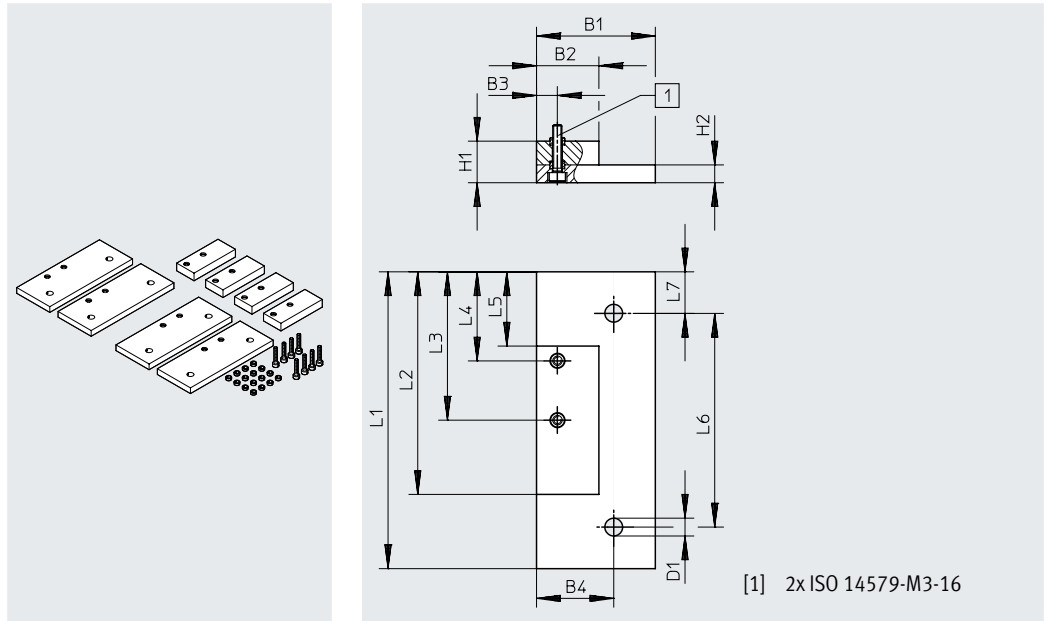

Dimensions and ordering data

For type [mm]	B1	B2	B3	B4	D1 ∅	H1	H2
EXCL-15	40	21	7	26	6	14	6

For type [mm]	L1	L2	L3	L4	L5	L6	L7	Weight [g]	Part no.	Type
EXCL-15	100	75	50	30	25	72	14	355	8185812	EHAM-MA-E23-15

Servo drive

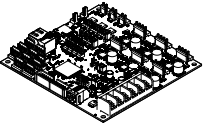
Designation	Description	Nominal voltage Load supply [V DC]	Number of digital logic inputs/outputs	Part no.	Type
	<ul style="list-style-type: none"> • PCB with 6-axis motion controller for the direct control of the EXCL's stepper motors. • Pre-configured for the three-dimensional gantry EXCL (motor and axis data/gantry size, homing) • 6 axes, 4.5 A per motor, open-loop, with inputs for the EXCL microswitch for homing • Programming with G-code • For direct integration in devices, not for H-rail mounting 	24	9/19	8168593	CMXL-ST6-NE-C4-1-MP