

Valve terminal VTUB-12

FESTO

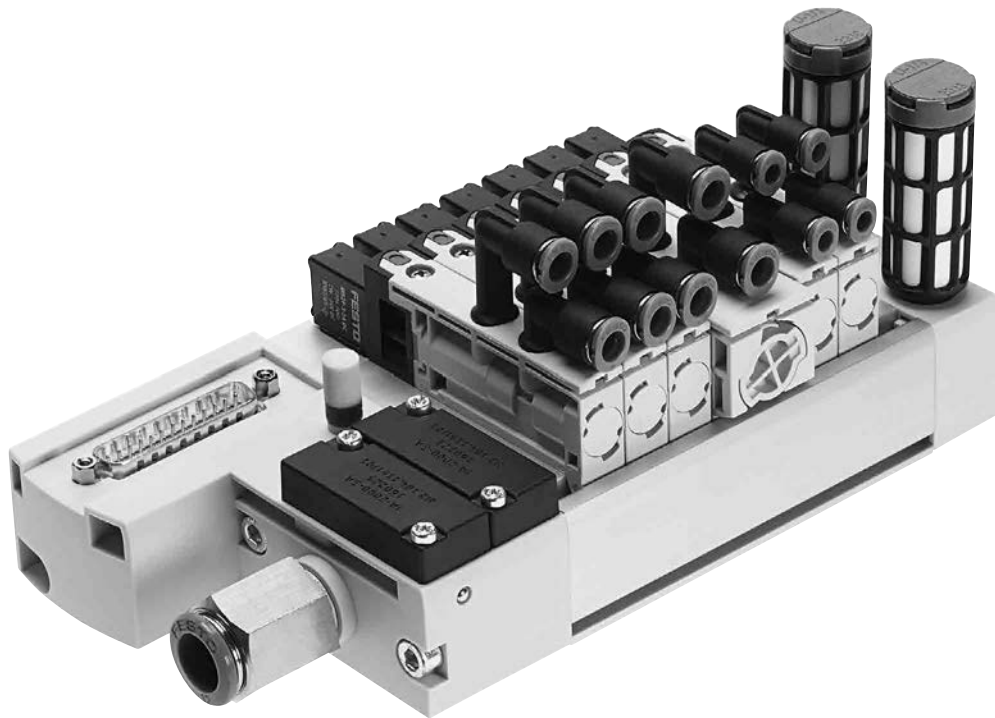

Key features



Innovative

- Cost-effective I-Port interface for bus nodes (CTEU)
- IO-Link mode for direct connection to a higher-level IO-Link master
- Lower installation costs thanks to multi-pin plug connection
- Valve terminal for a wide range of pneumatic applications
- Minimal space requirement
- Great flexibility during planning, assembly and operation
- Pneumatic distributor integrated on the valve terminal
- Suitable for use in dusty environments

Versatile

- Room for expansion with up to 35 valve positions on one valve terminal
- Flexibility of the pneumatic working ports provides a practical solution to different requirements
- Quick and easy replacement of fittings
- Optional manifold rail variant with LED signal status display
- Wall or H-rail mounting
- Subsequently expandable to up to 18 pressure zones
- Additional supply possible when an increased air rate is required

Reliable

- Manual override
- Long service life
- Sturdy thanks to the polymer housing and metal manifold rail

Easy to mount

- Ready-to-install and tested unit
- Lower ordering, installation and commissioning costs
- Wall or H-rail mounting
- Quick and secure installation thanks to integrated QS push-in connectors
- Easy valve assembly with just one screw

Note

Ordering system for valve terminal VTUB-12

→ Internet: vtub-12

Fieldbus CTEU

→ Internet: cteu

Key features

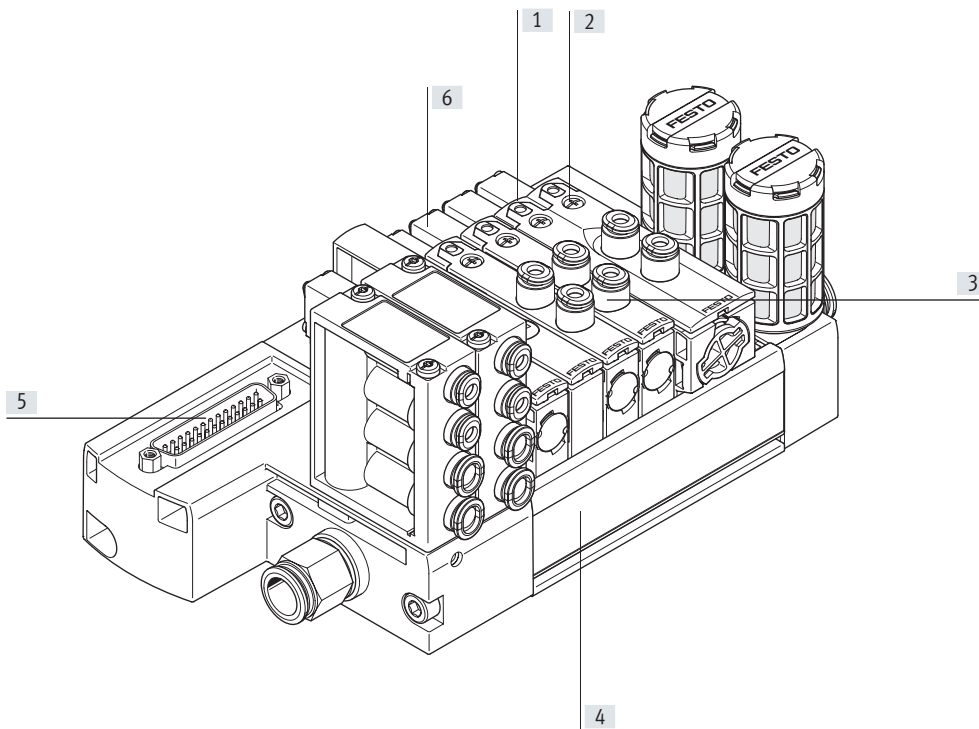

- [1] Safe operation:
manual override non-detenting,
non-detenting/detenting
- [2] Valve replacement made easy
Fast valve mounting with one
screw on the manifold rail
- [3] Choice of pneumatic outlets:
QS push-in connectors, straight
or angled
- [4] Space-saving with up to 35 valve
positions
- [5] Simple electrical connections
Multi-pin plug connection/I-Port
interface
- [6] Width 12 mm

Equipment options

Valve functions

- 5/2-way valve, single solenoid
- 5/2-way valve, double solenoid
- 3/2-way valve, closed
- 3/2-way valve, open

Electrical connection options

Multi-pin plug

- Sub-D 25-pin
- Sub-D 44-pin
- 2 ... 35 valve positions/
max. 35 solenoid coils

I-Port

- Fieldbus interface (CTEU)
- IO-Link mode
- 3 ... 35 valve positions/
max. 35 solenoid coils

Key features

Compressed air distributor

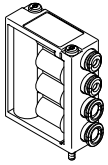

The compressed air distributor supplies the operating pressure from port 1 to up to four other ports. The compressed air distributor has integrated QS4 or QS6 connections.



Note

Number of compressed air distributors that can be used
→ p. 36 Pilot air supply

Selector plate/pilot control with external pilot air (optional)

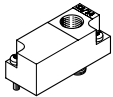

The VTUB-12 is intended for use with pilot air as standard. The valve terminal can be operated with external pilot air by mounting the selector plate VABF-C8-12-P6-...-Z instead of the

cover plate. The pilot air is then supplied via port 12/14 on the selector plate.

Manifold rail with multi-pin plug connection

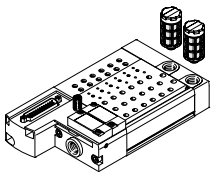

The manifold rail features a groove into which the semi in-line valves are latched and secured with just one screw.

The valve functions 3/2-way normally open or closed, 5/2-way single solenoid and 5/2-way double solenoid are available.

The valves can be supplied as semi in-line valves with cartridges QSP for tubing diameters 4 and 6 mm.

Manifold rail with optional LED signal status display

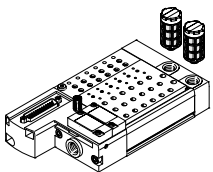

The manifold rail with multi-pin plug can optionally be ordered with LEDs (code L).

These indicate the signal states of the solenoid coils.

Manifold rail with I-Port interface

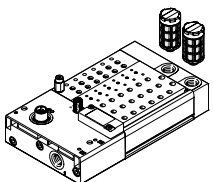

The manifold rail can be ordered with I-Port interface (code PT) and IO-Link (code LK) as a basis for bus nodes (CTEU) or in IO-Link mode for direct connection to a higher-level IO-Link master.

Key features

Sub-base for semi in-line valve

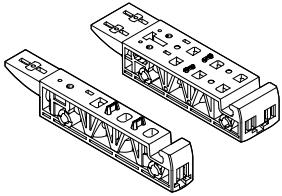

The valve VUVB-12 can be operated as an individual valve using an individual sub-base (single width for single solenoid valves or

double width for double solenoid valves). The power is supplied via the connecting cable NEBV and KMYZ and the adapter (M8x1)

with corresponding connecting cable (→ accessories, p. 36)

Cover plate

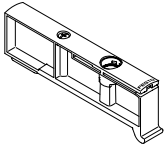
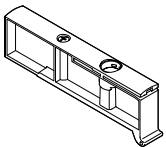

Plate without valve function for reserving valve positions on a valve terminal.

Valve and cover plate are attached to the manifold rail using one screw.

Power supply module



The power supply module occupies one valve position and can be used as an additional supply or for supplying a pressure zone.

The power supply module is attached to the manifold rail using one screw.

Separator for duct separation

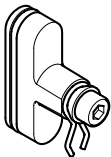

Pressure zone separation can be realised in duct 1 in the manifold rail. Up to 18 pressure zones can be created on the valve terminal in this way.

There must be at least 2 valve positions between 2 separators.

Key features

Integration of the I-Port interface/IO-Link

Different bus nodes are used for integration in the control systems of various manufacturers.

The following protocols are supported with the compatible bus node CTEU:

- CANopen
- DeviceNet
- EtherCAT
- CC-Link
- PROFIBUS DP
- AS-Interface
- PROFINET
- EtherNet/IP
- VARAN

Use of the electrical connection block CAPC permits decentralised installation of bus nodes CTEU on a further valve terminal or input modules with I-Port interfaces (→ installation system CTEU/CTEL)

System overview, example

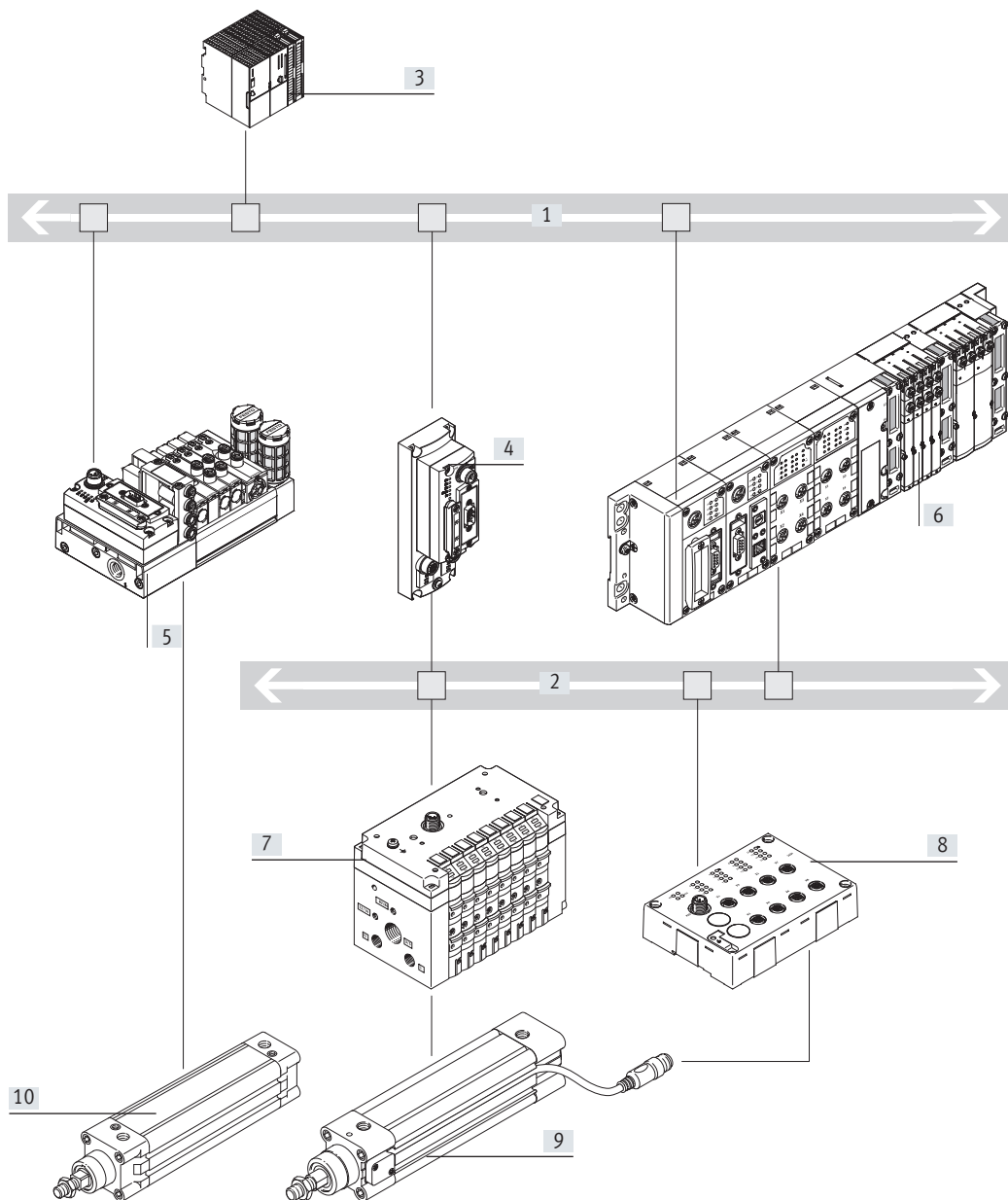

- [1] Fieldbus
- [2] IO-Link/ I-Port
- [3] PLC
- [4] Bus node CTEU (I-Port master) on electrical connection block CAPC
- [5] Valve terminal VTUB-12 with bus node CTEU
- [6] CPX terminal with bus node and CTEL master
- [7] Valve terminal CPV with I-Port interface/IO-Link
- [8] Input module CTSL
- [9] Pneumatic drive with sensor
- [10] Pneumatic drive

- Communication with the higher-level controller via fieldbus
- Use a bus node CTEU compatible with the fieldbus protocol
- Up to 64 inputs/outputs (solenoid coils), depending on the valve terminal

Peripherals overview

Overview – Valve terminal VTUB-12 with multi-pin plug connection, Sub-D

- Up to 20 valve positions/solenoid coils, 25-pin Sub-D multi-pin plug connection, code: M
 - From 21 valve positions/solenoid coils, 44-pin Sub-D multi-pin plug connection, code: M
- Valve terminals with electrical multi-pin plug connection are available with 2 to max. 35 valve positions.
- Each valve position can either be equipped with a valve, a power supply module or a cover plate. Double solenoid valves occupy two valve positions.
- A maximum of 35 solenoid coils can be actuated via the electrical multi-pin plug connection. Up to 18 pressure zones are possible.

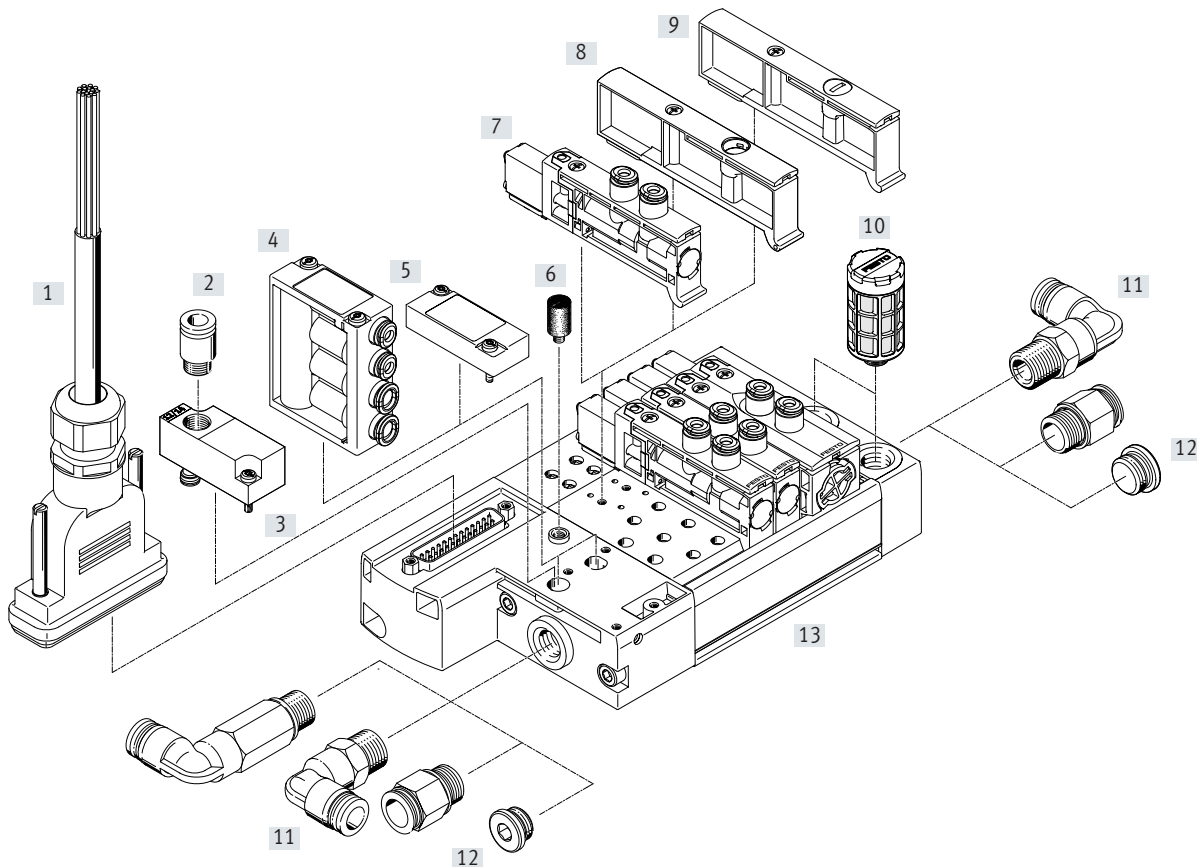

Accessories			Description	→ Page/Internet
[1]	Connecting cable	NEBV	For multi-pin plug connection, with Sub-D plug	38
[2]	Push-in fitting	QS	For connecting tubing with standard O.D.	39
[3]	Selector plate	VABF	Pilot control with external pilot air (optional)	37
[4]	Compressed air distributor	VABF	For connecting additional distributors to the air supply (port 1)	36
[5]	Cover plate	VABB	For vacant position (compressed air distributor)	36
[6]	Silencer	U	For venting hole	39
[7]	Solenoid valve	VUVB-12	–	35
[8]	Power supply module	VABF	For supplying pressure zones or for additional air supply	36
[9]	Cover plate	VABB	For vacant position (solenoid valve)	39
[10]	Silencer	U	For mounting in exhaust ports	39
[11]	Fittings	QS	For connecting tubing with standard O.D.	39
[12]	Blanking plug	B	For sealing the air supply port	37
[13]	Manifold rail	VABM	With multi-pin plug connection, for connecting max. 35 valves	35
–	Separator	VABD	For duct separation in duct 1, for creating pressure zones	37

Peripherals overview

Overview – Valve terminal VTUB-12 with I-Port interface/IO-Link

- Up to 35 valve positions/solenoid coils
 - I-Port interface connection type, code: PT
 - IO-Link connection type, code: LK
- Each valve position can either be equipped with a valve, a power supply module or a cover plate.

Double solenoid valves occupy two valve positions.
The electrical supply/transmission of communication data takes place via an M12 plug. The valve terminal can be equipped with 3 ... 35 valves. Up to 18 pressure zones are possible.

The following protocols are supported when using the associated bus node CTEU:

- DeviceNet
- CANopen
- PROFIBUS DP

- EtherCAT
- CC-Link
- AS-Interface
- PROFINET
- EtherNet/IP
- VARAN

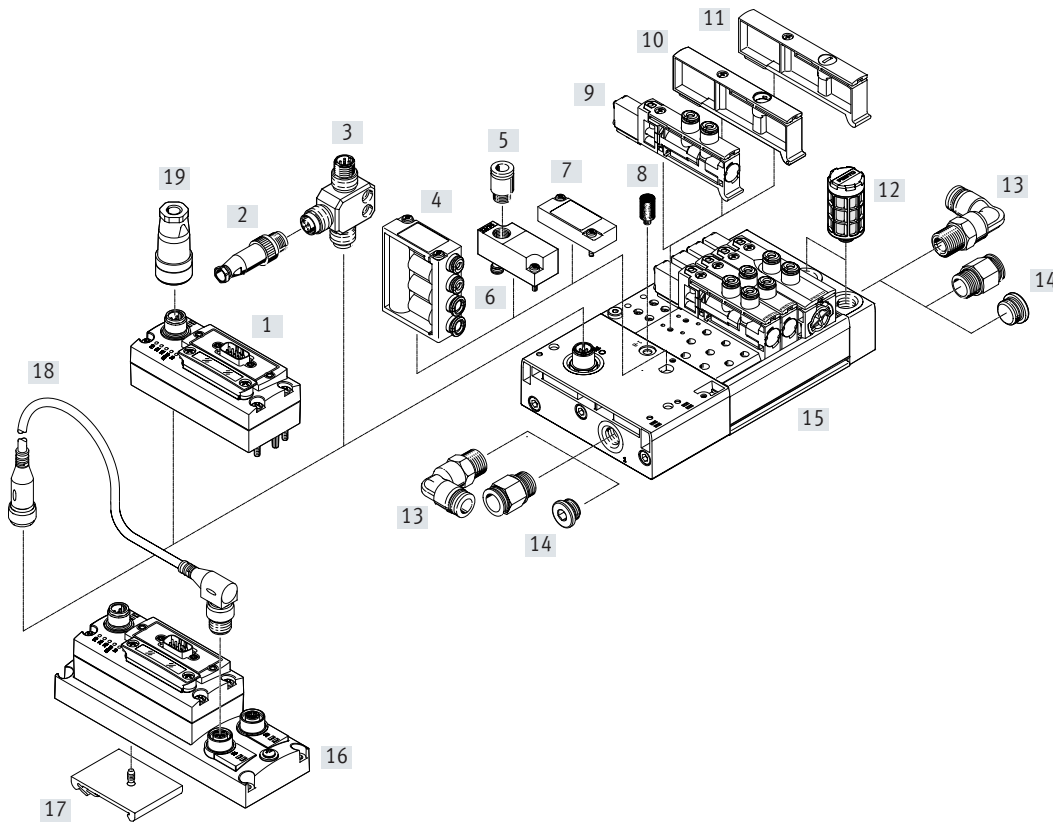

Accessories

Accessories			Description	→ Page/Internet
[1]	Bus node	CTEU	–	40
[2]	Plug	SEA-M12	Straight, for T-adapter FB-TA	40
[3]	T adapter	FB-TA	For IO-Link and load supply	40
[4]	Compressed air distributor	VABF	For connecting additional distributors to the air supply (port 1)	36
[5]	Push-in fitting	QS	–	39
[6]	Selector plate	VABF	Pilot control with external pilot air (optional)	37
[7]	Cover plate	VABB	For vacant position (compressed air distributor)	36
[8]	Silencer	U	For venting hole	39
[9]	Solenoid valve	VUVB-12	–	35
[10]	Power supply module	VABF	For supplying pressure zones or for additional air supply	37
[11]	Cover plate	VABB	For vacant position (solenoid valve)	36
[12]	Silencer	U	For mounting in exhaust ports	39
[13]	Fittings	QS	For connecting tubing with standard O.D.	39
[14]	Blanking plug	B	For sealing the air supply port	37
[15]	Manifold rail	VABM	With I-Port interface, for connecting max. 35 valves	36
[16]	Electrical connection block	CAPC-F1-E-M12	For connecting a second device with I-Port interface	41
[17]	H-rail mounting	CAFM-F1-H	For electrical connection block CAPC	41
[18]	Connecting cable	NEBU	–	41
[19]	Power supply socket	NTSD/FBSD	Power supply for CTEU bus nodes	41
–	Separator	VABD	For duct separation in duct 1, for creating pressure zones	37

Peripherals overview

Sub-base for semi in-line valve

- Single design for single solenoid valves
 - Double design for double solenoid valves
- Electrical connection via connecting cable NEBV or KMYZ, and adapter (M8x1) with corresponding connecting cable.

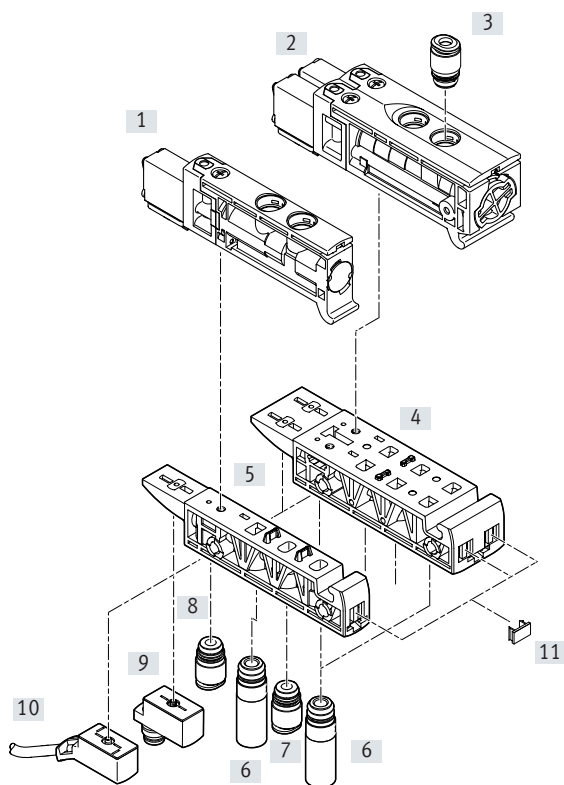

Accessories			Description	→ Page/Internet
[1]	Solenoid valve, single solenoid	VUVB-12	–	35
[2]	Double solenoid valve	VUVB-12	–	35
[3]	Push-in fitting	QS	For port 2, 4: cartridge with push-in connector	39
[4]	Sub-base	VABS	Double design for individual double solenoid valve	36
[5]	Sub-base	VABS	Single design for individual single solenoid valve	36
[6]	Silencer	AMTC	For port 3, 5 (optional)	39
[7]	Push-in fitting	QS	For port 1: cartridge with push-in connector	39
[8]	Push-in fitting	QS	For port 12, 14: cartridge with push-in connector (optional)	39
[9]	Adapter	VAVE	M8x1 (optional), LED	40
[10]	Connecting cable	NEBV, KMYZ	Connecting cable (optional)	38
[11]	Inscription label holder	IBS-6x10	–	37

Key features – Pneumatic components

Wide range of pneumatic components

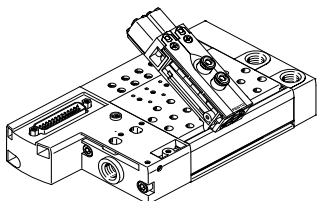

- The use of the same basic valves for the 3/2-way and 5/2-way valve function permits fast and flexible conversion and multiple use of parts.
- Flexible construction thanks to assembled and tested units or individual components as modules for individual configurations.
- Flow rates from 230 ... 400 l/min depending on the valve used and appropriate QS connections.

Changing fittings on port 2/4

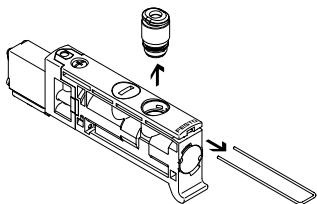

The cartridges (port 2/4) can be changed quickly and easily by removing the spring clip. The ports can be sealed by inserting a blanking plug (→ p. 37).

Connection to the valve

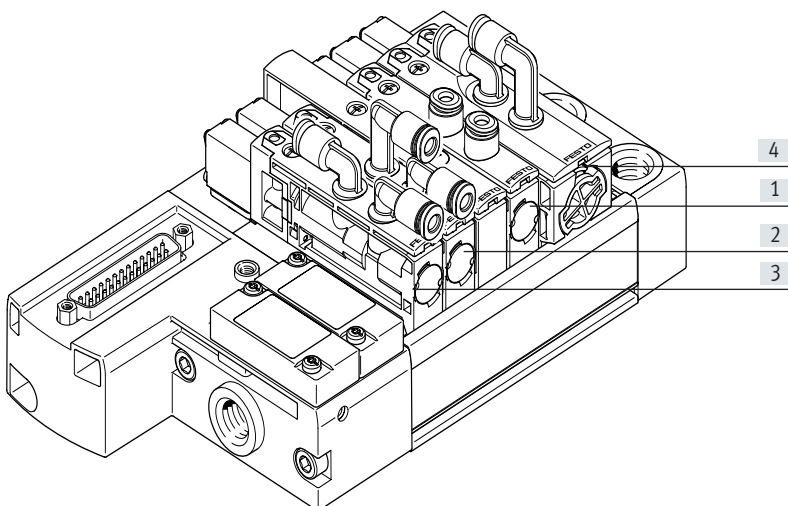

- [1] T (on top, inline)
- [2] TA (on top, angled outlet to the front)
- [3] TB (on top, angled outlet to the front/rear)
- [4] TC (on top, angled outlet to the rear)

Connection sizes:

- Push-in connector 4 mm (code P4)
- Push-in connector 6 mm (code P6)

Pilot air supply

Internal

The port for the pneumatic main supply is located on the left-hand sub-base (multi-pin plug connection/I-Port interface).

The internal pilot air (duct 12/14) is branched from duct 1 in the left-hand sub-base.

The air is branched using a compressed air distributor or a cover plate on the left-hand compressed air distributor port.

The multi-pin plug connection provides two compressed air distributor ports and the I-Port interface provides one.

External

External pilot air is supplied via the selector plate on the left-hand compressed air distributor port. It enables the pilot air and main supply to the valve terminal to be separated.

The multi-pin plug connection provides one compressed air distributor port and the I-Port interface does not provide any.

Key features – Pneumatic components

Creating pressure zones

Up to 18 pressure zones can be created using the separator VABD-C8 ... if different working pressures are required. The separators are inserted at the required location in duct 1 in the manifold rail and screwed into place. The following rules apply:

- Two pressure zones can be realised without an additional power supply module (VABF-C8 ...) if there is a compressed air supply at both ends. Only one separator in duct 1 is required for this.
- A power supply module (VABF-C8...) is additionally required after the third pressure zone; this module occupies one valve position.
- There must be at least 2 valve positions between 2 separators



Note

- Pressure zones can be freely configured with the VTUB-12.
- Duct separation does not result in any valve positions being lost; however, valve positions will be lost if an additional supply is required.
- If a valve terminal with duct separation is ordered via the configurator, the duct separation comes already labelled.
- Older manifold rails predating approx. mid-2013 cannot be retrofitted for the purpose of creating pressure zones.
- Additional information on assembly → Assembly instructions for VABD-C8-P1-D2

Duct separation

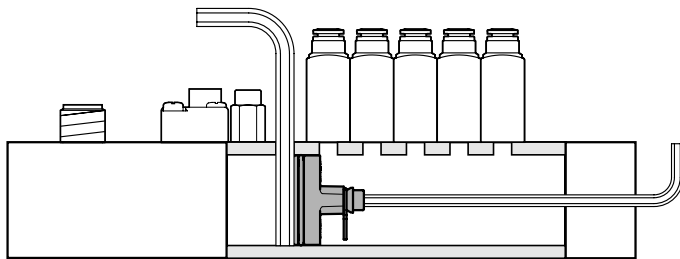

Duct separation and creation of pressure zones

- Remove the end plate
- Insert an Allen key (size 4) from above at the required position in duct 1 in the manifold rail as a stop.
- Using another Allen key, push separator VABD-C8 ... into duct 1 at the appropriate position as far as the stop and then turn the Allen key to secure in place.
- Fit the end plate
- Affix the enclosed symbol labels to the duct separation

Design

Valve replacement

The valves are attached to the aluminium manifold rail using one screw. This means that the valves can be easily replaced. Use of high-quality

polymer guarantees minimum weight and maximum performance.

Extension

Cover plates can be replaced by valves at a later date. The dimensions, mounting points and the pneumatic installation already carried out do not change.

Valve function	Code	Circuit symbol	Width		Description
			12 mm	24 mm	
M			■	–	5/2-way valve, single solenoid • Mechanical spring return • Non-reversible • Not suitable for vacuum
J			–	■	5/2-way valve, double solenoid • Non-reversible • Not suitable for vacuum
N			■	–	3/2-way valve, single solenoid • Normally open • Mechanical spring return • Non-reversible • Not suitable for vacuum
K			■	–	3/2-way valve, single solenoid • Normally closed • Mechanical spring return • Non-reversible • Not suitable for vacuum

Key features – Display and operation

Display and operation

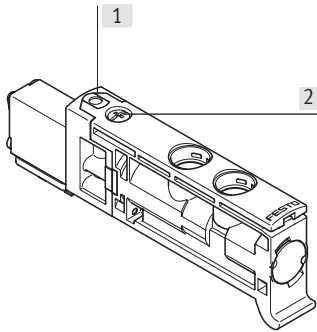

- [1] Manual override (non-detenting, non-detenting/detenting)
- [2] Screw for valve assembly

The manual override enables the valve to be switched without electronic control or power supply.

Manual override

Manual override with automatic return (non-detenting)

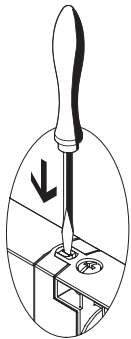

Press in the stem of the manual override with a pointed object or screwdriver.
 → Valve is in the switching position.
 Remove the pointed object or screwdriver.
 The spring force pushes the stem of the manual override back.
 → Valve returns to the normal position.

Manual override with lock (non-detenting/detenting)

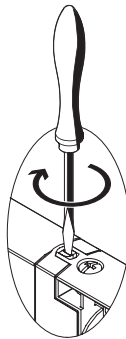

Press in the stem of the manual override with a pointed object or screwdriver until the valve switches and then turn the stem clockwise by 90° until the stop is reached.
 → Valve remains in the switching position.
 Turn the stem anti-clockwise by 90° until the stop is reached and then remove the pointed object or screwdriver. Spring force pushes the stem of the manual override back.
 → Valve returns to the normal position

Note

A manually operated valve (manual override) cannot be reset electrically.

Conversely, an electrically actuated valve cannot be reset using the mechanical manual override.

Key features – Mounting

Valve terminal mounting

Sturdy valve terminal mounting thanks to:

- Through-holes for wall mounting
- H-rail mounting

Wall mounting

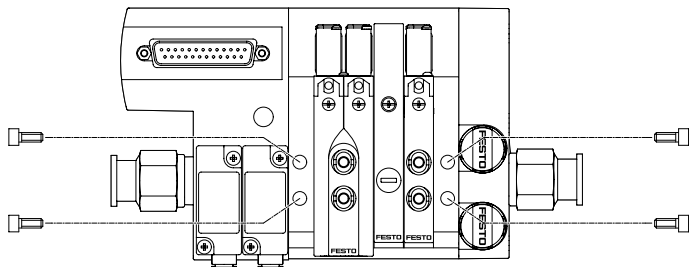

Sturdy terminal assembly thanks to four through-holes for wall mounting (M5 screws).

H-rail mounting

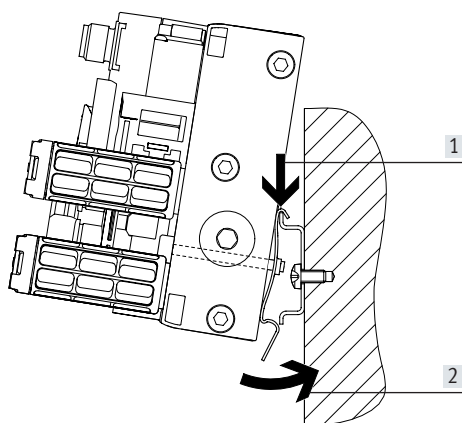

The H-rail mounting VAME-T-M5 consists of two mounting clips. These are attached to the manifold rail on the left and right (M5 screws). The lower through-holes on the manifold rail are used for this.

The valve terminal VTUB-12 is then lowered onto the H-rail from above → arrow [1] and clipped into the H-rail at the bottom → arrow [2].



Note

- Note the max. tightening torque of 2 Nm ($\pm 25\%$) for the screws for mounting the H-rail.
- Only horizontal H-rail mounting is permissible
- Mounting only permissible on H-rail TH 35-15 to EN 50022
- Vibration/shock loads are not permissible with H-rail mounting.

Key features – Electrical components

Multi-pin plug connection

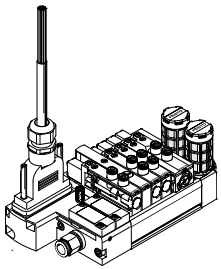

Control signals from the controller to the valve terminal are transmitted via a pre-assembled multi-core cable, which substantially reduces installation time.

The valve terminal can be equipped with 2 ... 35 valves.

Versions

- Sub-D connection

I-Port interface/IO-Link

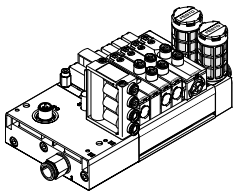

IO-Link

IO-Link is an interface that supplies data for communication in addition to the power supply. An IO-Link system consists of an IO-Link master and IO-Link devices. The IO-Link master acts as the interface to the higher-level controller (PLC) and controls communication with the connected IO-Link devices.

One device with IO-Link (e.g. an IO-Link valve terminal from Festo) can be connected to each port on an IO-Link master.

I-Port

The Festo-specific I-Port interface based on IO-Link offers the following connection options:

- Directly to the fieldbus by mounting a CTEU bus node
- Connection to a higher-order I-Port master from Festo

Overview

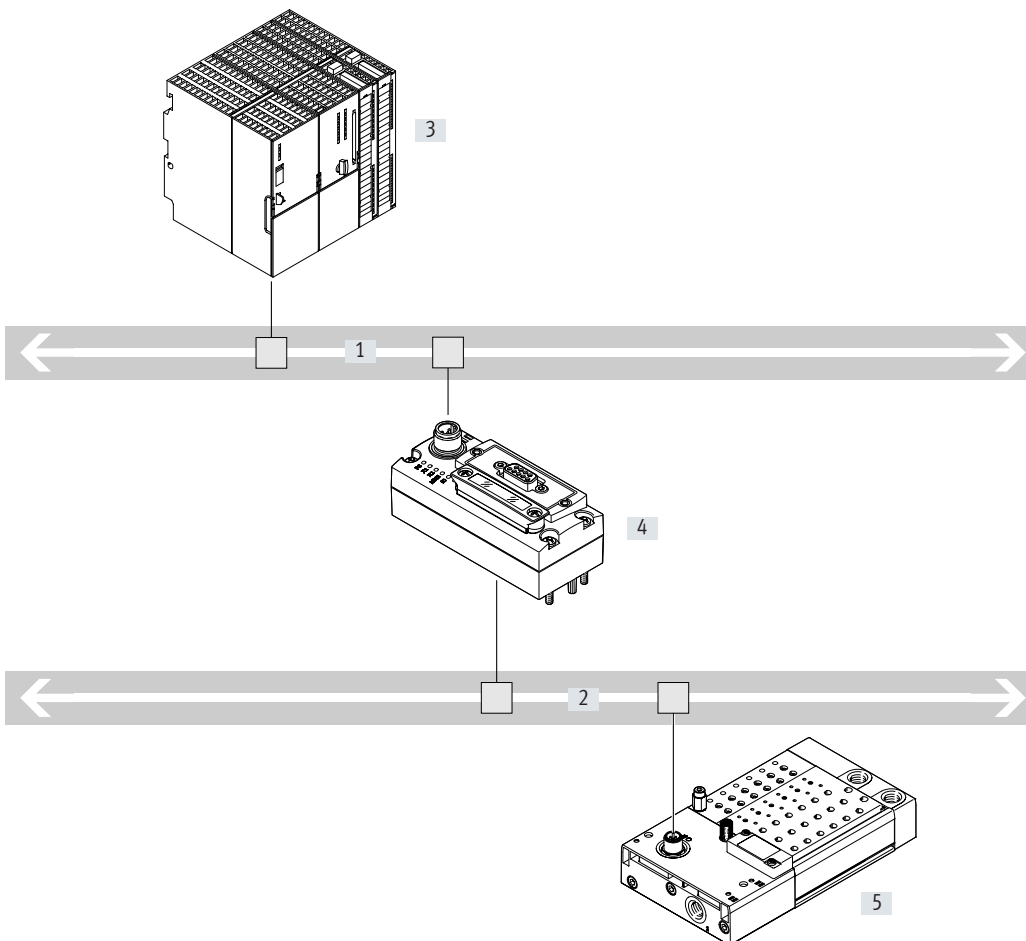

- [1] Fieldbus
- [2] IO-Link
- [3] PLC
- [4] CTEU bus node
IO-Link master
- [5] Valve terminal VTUB-12 with
I-Port interface/IO-Link

Key features – Electrical components

Protective circuit

Manifold rail with LED signal status display, multi-pin plug, 2-20 valve positions

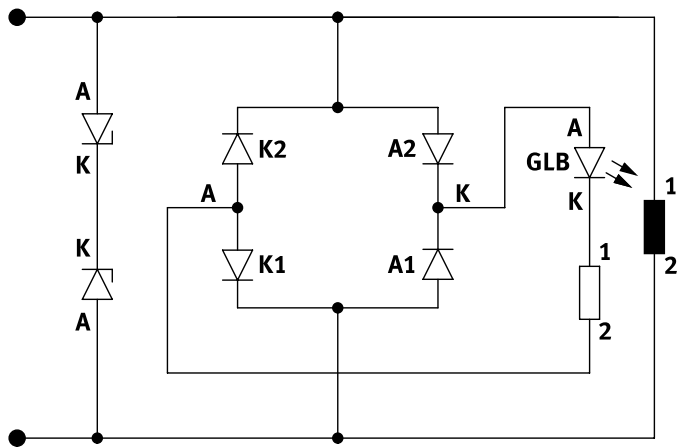

Note

The electrical protective circuit only relates to the optional LED variant with the multi-pin plug connection.

Manifold rail with LED signal status display, multi-pin plug, 21-35 valve positions

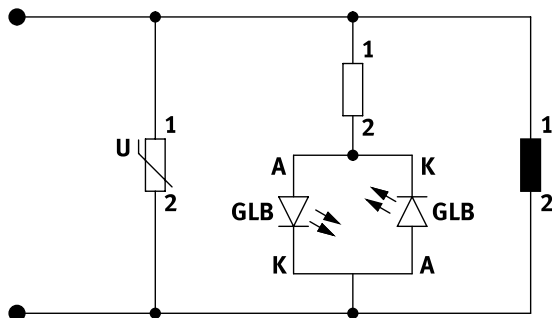

Electrical multi-pin plug connection

The following multi-pin plug connections are available for the valve terminal VTUB-12:

- Sub-D multi-pin plug connection (25-pin)
- Sub-D multi-pin plug connection (44-pin)

Pins 1 ... 44 are used for addresses 0 ... 43 in order.

If fewer than 44 addresses are used for the valve terminal, the remaining pins are left free.

Pins 22 ... 25 or 41 ... 44 are reserved for the neutral conductor or 24 V respectively.

The valves are switched using positive or negative logic (positive switching or negative switching). Mixed operation is not permitted.

Each pin on the multi-pin plug can actuate exactly one solenoid coil. If the maximum configurable number of valve positions is 35, then 35 valves can be addressed with one solenoid coil (single solenoid).





Note

A double solenoid valve occupies two valve positions.

With 17 or more valve positions, the number of available valve positions for double solenoid valves decreases.

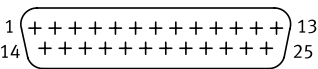
Key features – Electrical components

Pin allocation – Sub-D plug, 25-pin		Pin	Address/coil	15-wire, NEBV-S1...25-K...-LE15 Wire colour ¹⁾ of connecting cable	25-wire, NEBV-S1...25-K...-LE25
	1	0	WH	WH	
	2	1	BN	BN	
	3	2	GN	GN	
	4	3	YE	YE	
	5	4	GY	GY	
	6	5	PK	PK	
	7	6	BU	BU	
	8	7	RD	RD	
	9	8	BK	BK	
	10	9	VT	VT	
	11	10	GY PK	GY PK	
	12	11	RD BU	RD BU	
	13	12	–	GN WH	
	14	13	–	BN GN	
	15	14	–	YE WH	
	16	15	–	BN YE	
	17	16	–	GY WH	
	18	17	–	BN GY	
	19	18	–	WH PK	
	20	19	–	BN PK	
 <p>Note The drawing shows the view onto the pins of the Sub-D plug.</p>	21	–	–	BU WH	
	22	0 V/24 V	–	BN BU	
	23	0 V/24 V	GN WH	RD WH	
	24	0 V/24 V	BN GN	BN RD	
	25	0 V/24 V	YE WH	BK WH	

1) To IEC 757

Key features – Electrical components

Pin allocation – Sub-D plug, 44-pin		NEBV-S1...44-K...-LE39						
		Pin	Address	Wire colour ¹⁾ Connecting cable		Pin	Address	Wire colour ¹⁾ Connecting cable
<p>Note The drawing shows the view onto the pins of the Sub-D plug.</p>	1	0	WH		23	22	WH RD	
	2	1	BN		24	23	BN RD	
	3	2	GN		25	24	WH BK	
	4	3	YE		26	25	BN BK	
	5	4	GY		27	26	GY GN	
	6	5	PK		28	27	YE GY	
	7	6	BU		29	28	PK GN	
	8	7	RD		30	29	YE PK	
	9	8	BK		31	30	GN BU	
	10	9	VT		32	31	YE BU	
	11	10	GY PK		33	32	GN RD	
	12	11	RD BU		34	33	YE RD	
	13	12	WH GN		35	34	GN BK	
	14	13	BN GN		36	–	–	
	15	14	WH YE		37	–	–	
	16	15	YE BN		38	–	–	
	17	16	WH GY		39	–	–	
	18	17	GY BN		40	–	–	
	19	18	WH PK		41	0 V	YE BK	
	20	19	PK BN		42	0 V	GY BU	
	21	20	WH BU		43	0 V	PK BU	
	22	21	BN BU		44	0 V	GY RD	

1) To IEC 757

Pin allocation – Sub-D plug, 44-pin		NEBV-S1...44-K...-LE44						
		Pin	Address	Wire colour ¹⁾ Connecting cable		Pin	Address	Wire colour ¹⁾ Connecting cable
<p>Note The drawing shows the view onto the pins of the Sub-D plug.</p>	1	0	WH		23	22	WH RD	
	2	1	BN		24	23	BN RD	
	3	2	GN		25	24	WH BK	
	4	3	YE		26	25	BN BK	
	5	4	GY		27	26	GY GN	
	6	5	PK		28	27	YE GY	
	7	6	BU		29	28	PK GN	
	8	7	RD		30	29	YE PK	
	9	8	BK		31	30	GN BU	
	10	9	VT		32	31	YE BU	
	11	10	GY PK		33	32	GN RD	
	12	11	RD BU		34	33	YE RD	
	13	12	WH GN		35	34	GN BK	
	14	13	BN GN		36	35	YE BK	
	15	14	WH YE		37	35	GY BU	
	16	15	YE BN		38	37	PK BU	
	17	16	WH GY		39	38	GY RD	
	18	17	GY BN		40	39	PK RD	
	19	18	WH PK		41	0 V	GY BK	
	20	19	PK BN		42	0 V	PK BK	
	21	20	WH BU		43	0 V	BU BK	
	22	21	BN BU		44	0 V	RD BK	

1) To IEC 757

Key features – Electrical components

Pin allocation – Adapter M8x1 with LED		Pin
Round plug, M8, 3-pin		
	VAVE-C8-1R8	
	1	Not used
	3	0V
	4	24 V
Round plug, M8, 4-pin		
	VAVE-C8-1R1	
	1	Not used
	2	Not used
	3	0V
	4	24 V

Protective circuit

Manifold rail with I-Port interface

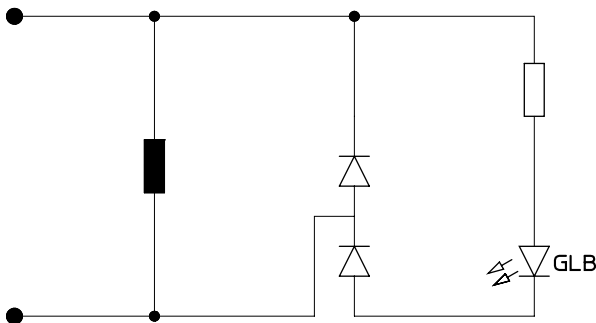

I-Port interface/IO-Link

The valve terminal VTUB-12 can be connected as follows via the I-Port:

- Directly to the fieldbus by mounting the CTEU bus node on the valve terminal
- To an IO-Link master (in IO-Link mode) via a cable

Up to 35 solenoid coils can be actuated. A valve position always occupies one address. The following assignment applies in this case:

- Less significant valve position (address) for coil 14
- More significant valve position (address) for coil 12

Addresses are allocated in ascending order without gaps, from left to right. The address allocation is independent of whether blanking plates or valves are used.

Note
 More information on CTEU
 → cteu
 Additionally required IODD for IO-Link mode
 → www.festo.com

Pin allocation – I-Port interface/IO-Link ¹⁾		Pin	Allocation
	1	24 V electronics (logic voltage)	
	2	24 V valves (load voltage)	
	3	0 V electronics (logic)	
	4	COM I-Port communication signal	
	5	0 V valves (load)	

1) Plug, 5-pin, M12, A-coded

Instructions for use

System equipment

Operate your system with unlubricated compressed air if possible. Festo valves and cylinders are designed so that, if used as intended, they will not require additional lubrication and will still achieve a long service life.

The quality of compressed air downstream of the compressor must correspond to that of unlubricated compressed air. If possible, do not operate the entire system with lubricated compressed air. The lubricators should, where possible, always be installed directly upstream of the actuator requiring them.

Incorrect additional oil and too high an oil content in the compressed air reduce the service life of the valve terminal.

Use Festo special oil OFSW-32 or the alternatives listed in the Festo catalogue (as specified in DIN 51524 HLP32; basic oil viscosity 32 CST at 40°C).

Bio-oils



When using bio-oils (oils which are based on synthetic or native esters, e.g. rapeseed oil methyl ester), the maximum residual oil content of 0.1 mg/m³ must not be exceeded (see ISO 8573-1 Class 2).

Mineral oils

When using mineral oils (e.g. HLP oils to DIN 51524, parts 1 to 3) or similar oils based on poly-alpha-olefins (PAO), the maximum residual oil content of 5 mg/m³ must not be exceeded (see ISO 8573-1 Class 4).

A higher residual oil content is not permitted, regardless of the compressor oil, because the permanent lubrication would otherwise be flushed out over a period of time.

Data sheet – Valve terminal VTUB-12 with multi-pin plug connection

-  Voltage
24 V DC
-  Pressure
0.28 ... 0.8 MPa
2.8 ... 8 bar
-  Temperature range
-5 ... 60°C

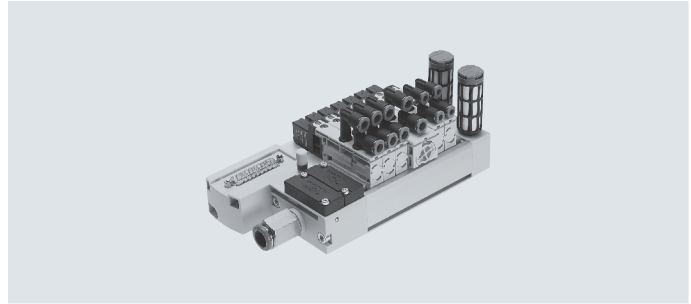

General technical data			3/2C	3/2U	5/2-way, single solenoid	5/2-way, double solenoid
Valve function						
Design			Poppet valve with spring return			Poppet valve with self-holding function
Valve function			Closed	Open	Single solenoid	Double solenoid
Sealing principle			Soft			
Actuation type			Electrical			
Reset method			Mechanical spring			–
Type of control			Piloted			
Pilot air supply			Internal			
			External			
Flow direction			Non-reversible			
Exhaust air function			Cannot be throttled			
Manual override			Non-detenting, non-detenting/detenting			
Type of mounting			With through-hole			
Width	[mm]		12			24
Nominal width	[mm]		4			
Max. no. of valve positions			35		35	17
Max. number of pressure zones			18			
Standard nominal flow rate	qnN	[l/min]	400			
Pneumatic connection			1; 3; 5		G1/4	
			2; 4		QS-4 or QS-6	
			12; 14		G1/8	



Operating and environmental conditions			3/2C	3/2U	5/2-way, single solenoid	5/2-way, double solenoid
Valve function						
Operating medium			Compressed air to ISO 8573-1:2010 [7:4:4]			
Note on the operating/pilot medium			Lubricated operation possible (in which case lubricated operation will always be required)			
Operating pressure	Internal pilot air	[MPa]	0.2 ... 0.8	0.28 ... 0.8		
		[bar]	2 ... 8	2.8 ... 8		
	External pilot air	[MPa]	0 ... 0.8			
		[bar]	0 ... 8			
Pilot pressure		[MPa]	0.2 ... 0.8	0.28 ... 0.8		
		[bar]	2 ... 8	2.8 ... 8		
Ambient temperature		[°C]	-5 ... 60			
Temperature of medium		[°C]	-5 ... 60			

Safety characteristics	
CE marking (see declaration of conformity)	To EU EMC Directive
KC mark	KC EMC
Max. positive test pulse with 0 signal	[µs] 800
Max. negative test pulse with 1 signal	[µs] 300
Shock resistance	Shock test with severity level 1 to FN 942017-5 and EN 60068-2-27
Vibration resistance	Transport application test with severity level 1 to FN 942017-4 and EN 60068-2-6
Well-tried component	Yes

Data sheet – Valve terminal VTUB-12 with multi-pin plug connection

Product weight		
Approx. weights	[g]	
Valves		
• 5/2-way single solenoid (code M), ducted solenoid exhaust air	27.8	
• 5/2-way double solenoid (code J), ducted solenoid exhaust air	57.4	
• 5/2-way single solenoid (code M), unducted solenoid exhaust air	27.5	
• 5/2-way double solenoid (code J), unducted solenoid exhaust air	57.1	
• 3/2-way closed (code K), ducted/unducted solenoid exhaust air	26.3	
• 3/2-way open (code N), unducted solenoid exhaust air	28.1	
• 3/2-way open (code N), ducted solenoid exhaust air	29.4	
Manifold rail		
• Multi-pin plug with Sub-D plug, 25-pin	2 valve positions	382
	4 valve positions	484
	6 valve positions	585
	8 valve positions	687
	10 valve positions	788
	12 valve positions	890
	14 valve positions	992
	16 valve positions	1093
	18 valve positions	1195
	20 valve positions	1296
• Multi-pin plug with Sub-D plug, 44-pin	24 valve positions	1500
	28 valve positions	1704
	32 valve positions	1907
	35 valve positions	2060
Cover plate for vacant position	13.8	
Power supply module for pressure zones or additional supply	13.8	
Separator for duct separation	9.8	
Compressed air distributor Q4, Q6, Q4-Q6	65.6, 59, 62.3	
Cover plate for compressed air distributor	8.4	
Selector plate	38.8	
Sub-base for individual valve, single width	15	
Sub-base for individual valve, double width	30	
Electrical data		
Nominal operating voltage	[V DC]	24, reverse polarity protected
Permissible voltage fluctuations		±10%
Electrical power consumption per solenoid coil	[W]	1
Degree of protection to EN 60529		IP65
Duty cycle	[%]	100
Materials		
Manifold rail	Wrought aluminium alloy	
Solenoid valve housing	PA-reinforced	
Solenoid valve seals	NBR, TPE-U	
Solenoid valve piston spool	Wrought aluminium alloy	
Cover plate housing, additional supply housing	PA-reinforced	
Separator for duct separation	Beryllium bronze, brass	
Compressed air distributor, compressed air distributor cover plate	PA-reinforced	
Selector plate	Wrought aluminium alloy	
Sub-base for individual valve	PA-reinforced	
Note on materials	RoHS-compliant	
Note on materials, power supply module	RoHS-compliant, free of copper and PTFE	

Technical data – Valve terminal VTUB-12 with I-Port interface, IO-Link

-  Voltage
24 V DC
-  Pressure
0.28 ... 0.8 MPa
2.8 ... 8 bar
-  Temperature range
-5 ... 60°C

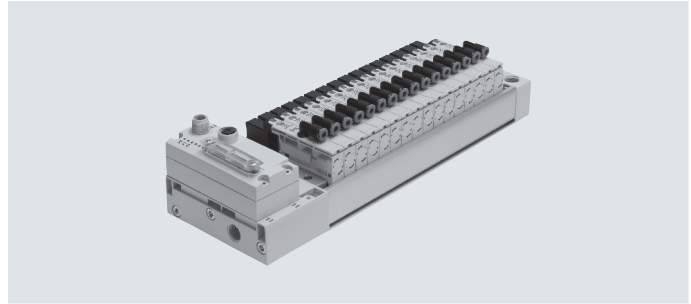

General technical data		3/2C	3/2U	5/2-way, single solenoid	5/2-way, double solenoid
Valve function					
Design		Poppet valve with spring return			Poppet valve with self-holding function
Valve function		Closed	Open	Single solenoid	Double solenoid
Sealing principle		Soft			
Actuation type		Electrical			
Reset method		Mechanical spring			-
Type of control		Piloted			
Pilot air supply		Internal			
		External			
Flow direction		Non-reversible			
Exhaust air function		Cannot be throttled			
Manual override		Non-detenting, non-detenting/detenting			
Type of mounting		With through-hole			
Width	[mm]	12			24
Nominal width	[mm]	4			
Max. no. of valve positions		35		35	17
Max. number of pressure zones		18			
Standard nominal flow rate	q _{nN}	400			
Pneumatic connection		1; 3; 5			
		2; 4		QS-4 or QS-6	
		12; 14			

Operating and environmental conditions		3/2C	3/2U	5/2-way, single solenoid	5/2-way, double solenoid
Valve function					
Operating medium		Compressed air to ISO 8573-1:2010 [7:4:4]			
Note on the operating/pilot medium		Lubricated operation possible (in which case lubricated operation will always be required)			
Operating pressure	Internal pilot air	[MPa]	0.2 ... 0.8	0.28 ... 0.8	
		[bar]	2 ... 8	2.8 ... 8	
	External pilot air	[MPa]	0 ... 0.8		
		[bar]	0 ... 8		
Pilot pressure		[MPa]	0.2 ... 0.8	0.28 ... 0.8	
		[bar]	2 ... 8	2.8 ... 8	
Ambient temperature		[°C]	-5 ... 50		
Temperature of medium		[°C]	-5 ... 50		

 **Note**
The CE marking for the valve terminal with I-Port interface applies up to a maximum connecting cable length of 30 m.

Technical data – Valve terminal VTUB-12 with I-Port interface, IO-Link

Safety characteristics		
CE marking (see declaration of conformity)		To EU EMC Directive
KC mark		KC EMC
Max. positive test pulse with 0 signal	[µs]	800
Max. negative test pulse with 1 signal	[µs]	300
Shock resistance		Shock test with severity level 1 to FN 942017-5 and EN 60068-2-27
Vibration resistance		Transport application test with severity level 1 to FN 942017-4 and EN 60068-2-6
Well-tried component		Yes
Product weight		
Approx. weights		[g]
Valves		
• 5/2-way single solenoid (code M), ducted solenoid exhaust air		27.8
• 5/2-way double solenoid (code J), ducted solenoid exhaust air		57.4
• 5/2-way single solenoid (code M), unducted solenoid exhaust air		27.5
• 5/2-way double solenoid (code J), unducted solenoid exhaust air		57.1
• 3/2-way closed (code K), ducted/unducted solenoid exhaust air		26.3
• 3/2-way open (code N), unducted solenoid exhaust air		28.1
• 3/2-way open (code N), ducted solenoid exhaust air		29.4
• I-Port interface with M12 plug	4 valve positions	521
	6 valve positions	627
	8 valve positions	727
	10 valve positions	834
	12 valve positions	940
	14 valve positions	1040
	16 valve positions	1145
	18 valve positions	1251
	20 valve positions	1358
	24 valve positions	1562
	28 valve positions	1775
	32 valve positions	1982
	35 valve positions	2138
Cover plate for vacant position		13.8
Power supply module for pressure zones or additional supply		13.8
Separator for duct separation		9.8
Compressed air distributor Q4, Q6, Q4-Q6		65.6, 59, 62.3
Cover plate for compressed air distributor		8.4
Selector plate		38.8
Sub-base for individual valve, single width		15
Sub-base for individual valve, double width		30

Technical data – Valve terminal VTUB-12 with I-Port interface, IO-Link

Electrical data		
Nominal operating voltage	[V DC]	24, reverse polarity protected
Permissible voltage fluctuations		±10%
Electrical power consumption per solenoid coil	[W]	1
Degree of protection to EN 60529		IP65
Duty cycle	[%]	100
Intrinsic current consumption, logic supply	[mA]	30
Intrinsic current consumption, valve supply	[mA]	30
Max. cable length	[m]	20
Min. cable cross section	[mm ²]	1
Baud rate	COM3	[kbps] 230.4
	COM2	[kbps] 38.4

Materials	
Manifold rail	Wrought aluminium alloy
Solenoid valve housing	PA-reinforced
Solenoid valve seals	NBR, TPE-U
Solenoid valve piston spool	Wrought aluminium alloy
Cover plate housing, additional supply housing	PA-reinforced
Separator for duct separation	Beryllium bronze, brass
Compressed air distributor, compressed air distributor cover plate	PA-reinforced
Selector plate	Wrought aluminium alloy
Sub-base for individual valve	PA-reinforced
Note on materials	RoHS-compliant

Data sheet

Valve switching times [ms]			
Valve function	3/2	5/2-way, single solenoid	5/2-way, double solenoid
On	6	6	-
Off	14	14	-
Changeover	-	-	10

Pilot pressure as a function of operating pressure
(operating pressure with external pilot air),
pilot pressure 5/2 and 3/2U

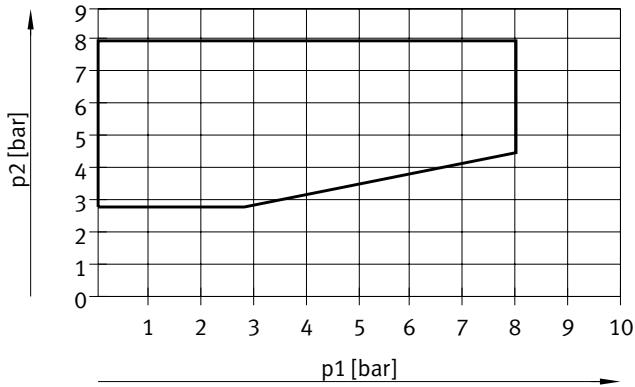

Pilot pressure as a function of operating pressure
(operating pressure with external pilot air),
pilot pressure 3/2C

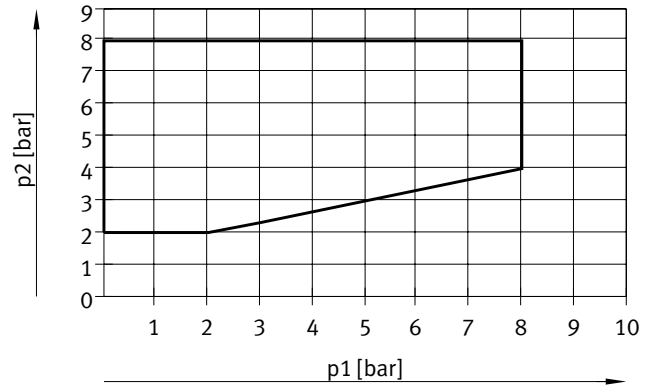

Flow rate q per valve with multiple (n) valves switched simultaneously
(tolerance ± 20%)

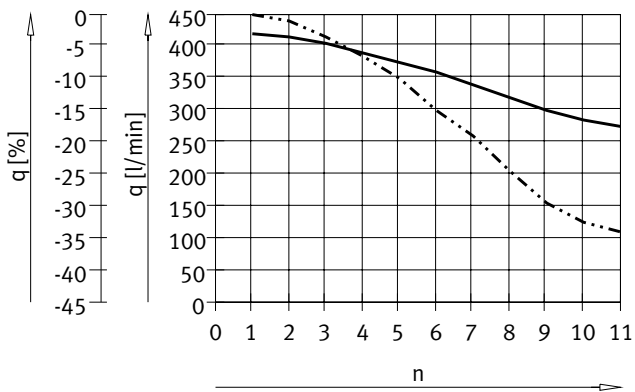

- Flow rate per valve
- - - - Loss per valve [%]

Data sheet

Materials

Sectional view – Valves

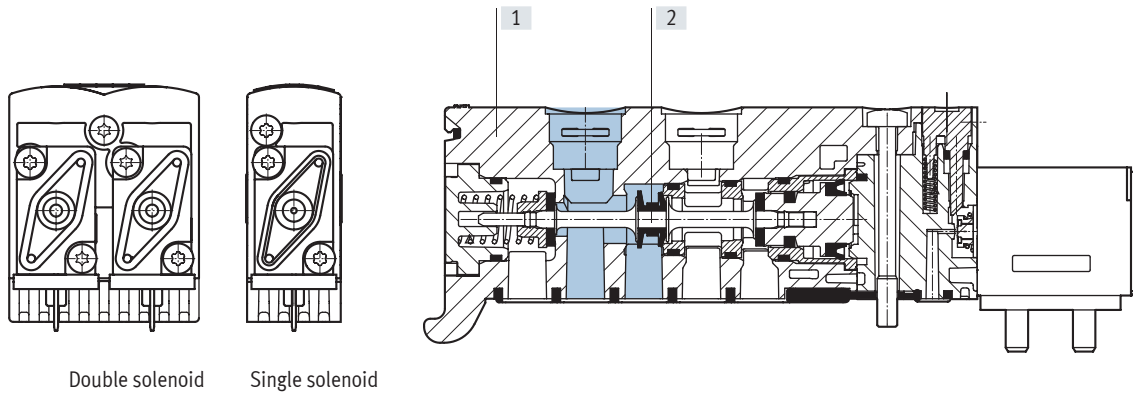

[1]	Housing	PA-reinforced
[2]	Piston slide	Wrought aluminium alloy
-	Seals	NBR, PUR
-	Manifold rail with multi-pin plug	Wrought aluminium alloy
-	Power supply module	PA-reinforced
-	Cover plate for vacant position	PA-reinforced
-	Selector plate	Wrought aluminium alloy

Dimensions – Power supply module

Download CAD data → www.festo.com

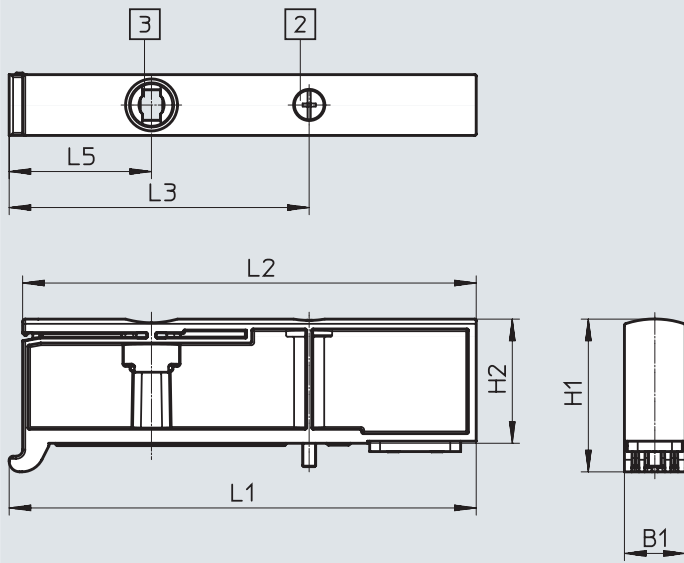

- [2] Retaining screw M2.5
- [3] Push-in connector QSP...10...-

Type	B1	H1	H2	L1	L2	L3	L5
VABF-C8-12-P3A5-QX	11.7	29.4	23.9	89.9	87.3	57.8	27.1

Data sheet

Dimensions – 3/2-way valve, single solenoid, normally open

Download CAD data → www.festo.com

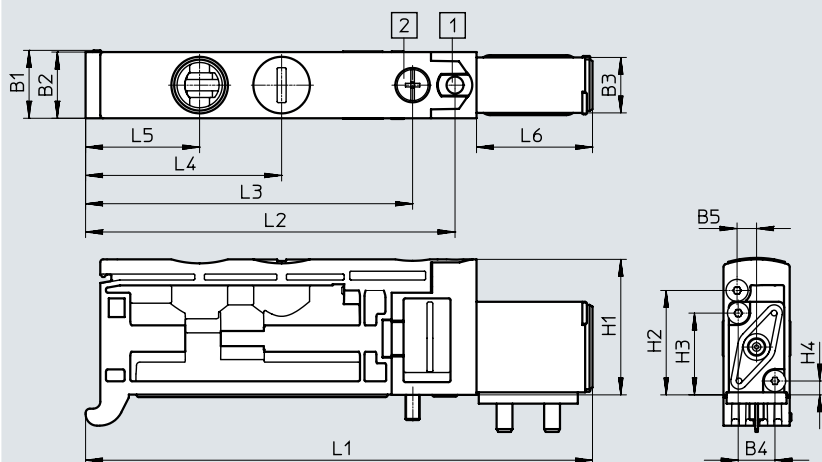

- [1] Manual override non-detenting or non-detenting/detenting
- [2] Retaining screw M2.5

Type	B1	B2	B3	B4	B5	H1	H2	H3	H4	L1	L2	L3	L4	L5	L6
VUVB-ST12-M32U-...-QX-1T1	12	11.7	9.8	6.5	3.5	24	18.4	14.5	2.5	89.6	65.3	57.8	34.7	20.2	20.5
VUVB-ST12-M32U-...-QX-D-1T1										89.9					20.8

Dimensions – 3/2-way valve, single solenoid, normally closed

Download CAD data → www.festo.com

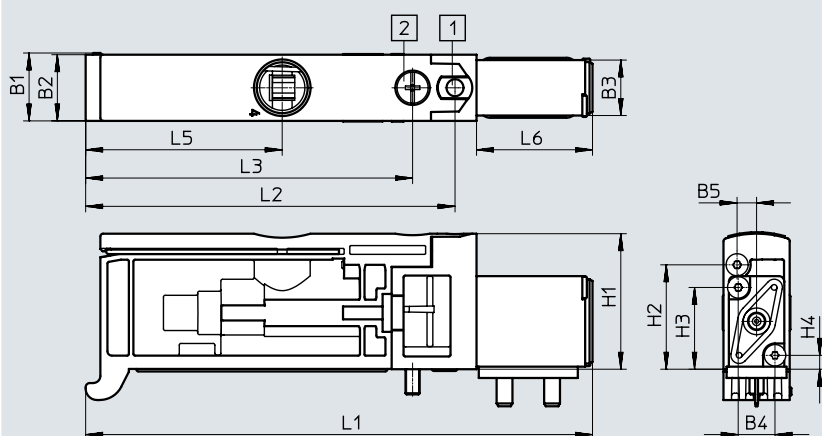

- [1] Manual override non-detenting or non-detenting/detenting
- [2] Retaining screw M2.5

Type	B1	B2	B3	B4	B5	H1	H2	H3	H4	L1	L2	L3	L5	L6
VUVB-ST12-M32C-...-QX-1T1	12	11.7	9.8	6.5	3.5	24	18.5	14.5	2.5	89.6	65.3	57.8	34.8	20.5
VUVB-ST12-M32C-...-QX-D-1T1										89.9				20.8

Data sheet

Dimensions – 5/2-way valve, single solenoid

Download CAD data → www.festo.com

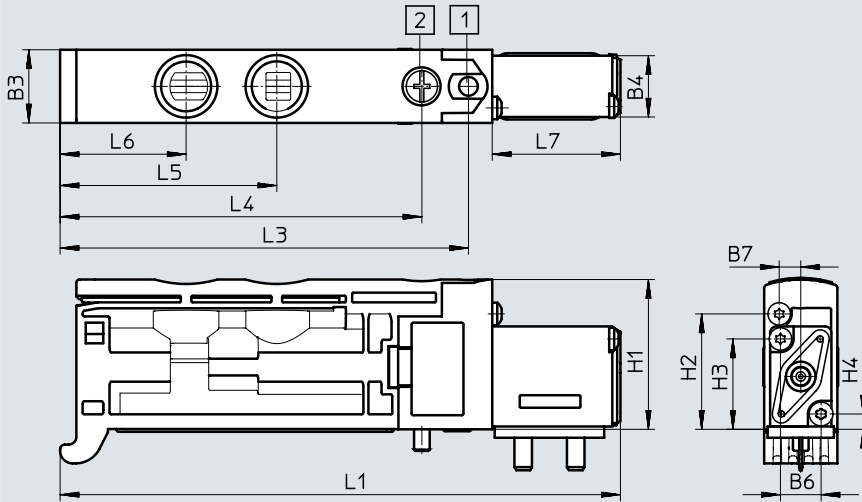

- [1] Manual override
- [2] Retaining screw

Type	B1	B2	B3	B4	B5	B6	B7	H1	H2	H3	H4	L1	L2	L3	L4	L5	L6	L7
VUVB-ST12-M52-MZH-QX-1T1	-	-	12	9.8	-	6.5	3.5	24	18.5	14.5	2.5	89.6	-	65.3	57.8	34.7	20.2	20.5
VUVB-ST12-M52-MZH-QX-D-1T1												89.9						20.8

Dimensions – 5/2-way valve, double solenoid

Download CAD data → www.festo.com

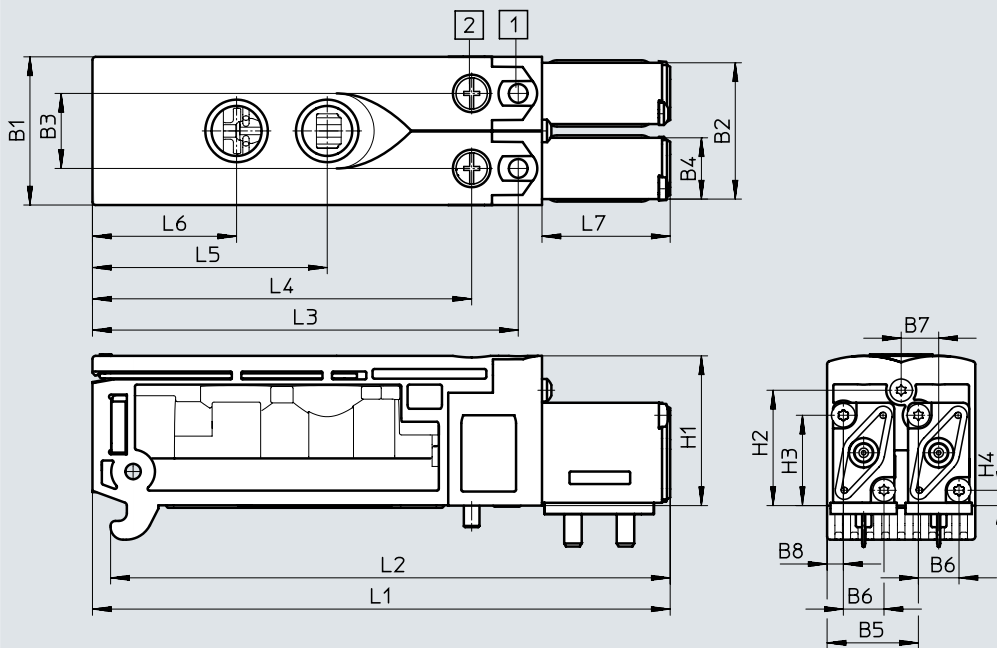

- [1] Manual override
- [2] Retaining screw

Type	B1	B2	B3	B4	B5	B6	B7	H1	H2	H3	H4	L1	L2	L3	L4	L5	L6	L7
VUVB-ST12-B52-ZH-QX-1T1	23.7	21.8	12	9.8	14.6	6.5	6	24	18.5	14.5	2.5	92.4	89.5	68.1	60.7	37.6	23.1	20.5
VUVB-ST12-B52-ZH-QX-D-1T1												92.7	89.8					20.8

Data sheet

Dimensions – Manifold rail with multi-pin plug

Download CAD data → www.festo.com

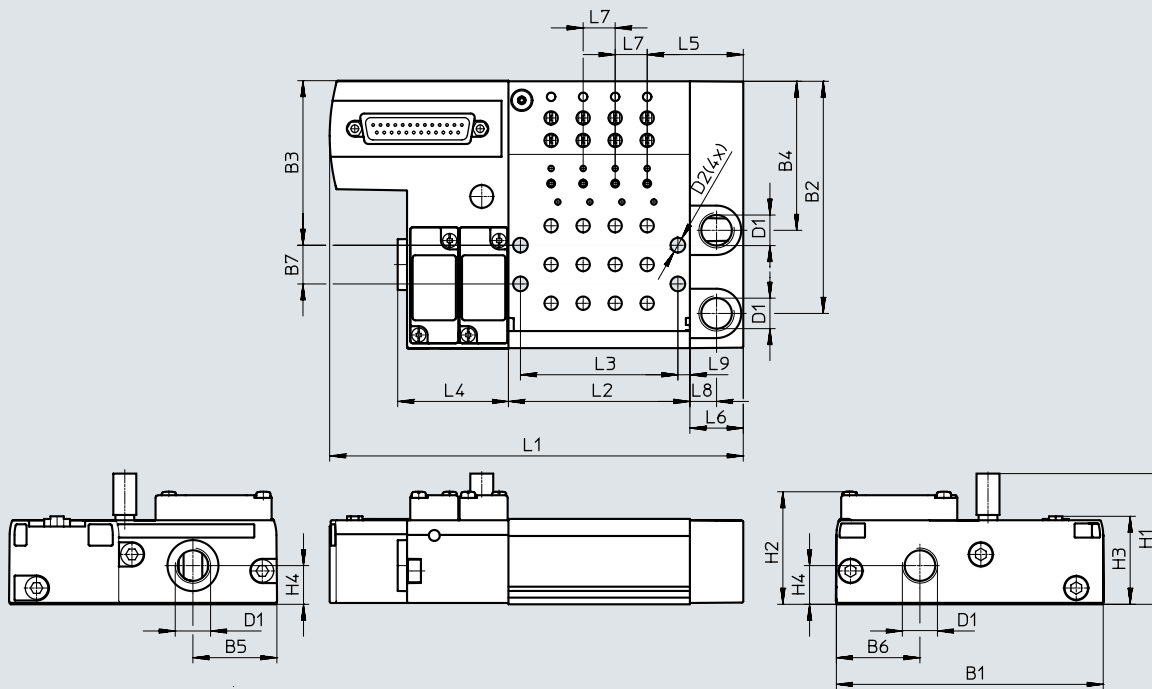

n Number of valve positions
(2...35)

Type	B1	B2	B3	B4	B5	B6	B7	D1	D2	H1	H2	H3	H4
VABM-C8-12E	100	87	61.5	55.9	31.5	31.5	14.5	G1/4	5.5	49.3	42.2	33	14.5

Type	L1	L2	L3	L4	L5	L6	L7	L8	L9
VABM-C8-12E	(nx12)+107	(nx12)+20	(nx12)+11	41.5	36	20	12	10	4.5

Data sheet

Dimensions – Manifold rail with I-Port interface

Download CAD data → www.festo.com

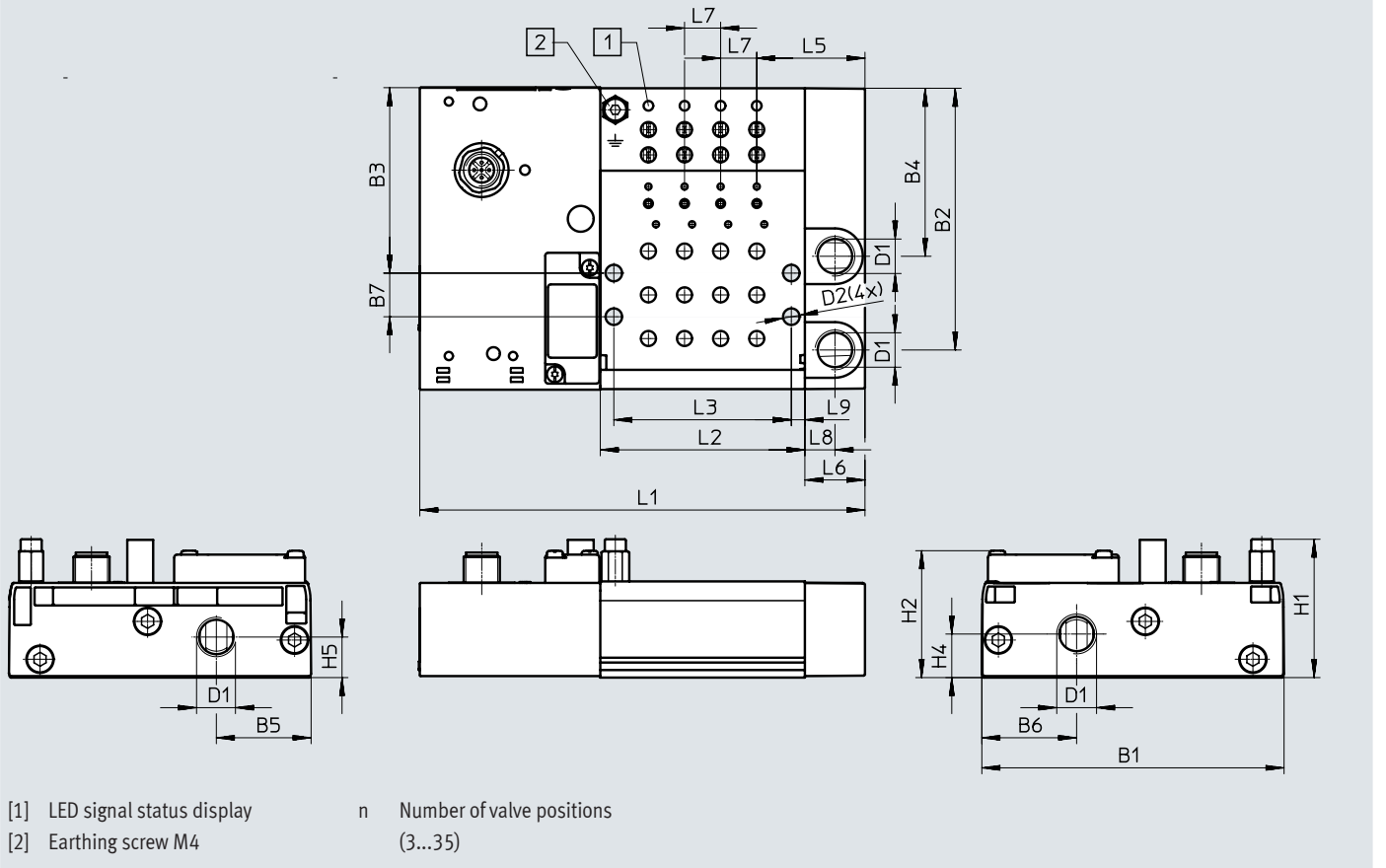

Type	B1	B2	B3	B4	B5	B6	B7	D1	D2-σ	H1	H2	H4	H5
VTUB-12	100	87	61.5	55.9	31.5	31.5	14.5	G1/4	5.5	46.1	42.2	14.5	13.5

Type	L1	L2	L3	L5	L6	L7	L8	L9
VTUB-12	(nx12)+100	(nx12)+20	(nx12)+11	36	20	12	10	4.5

Data sheet

Dimensions – Valve terminal with electrical multi-pin plug

Download CAD data → www.festo.com

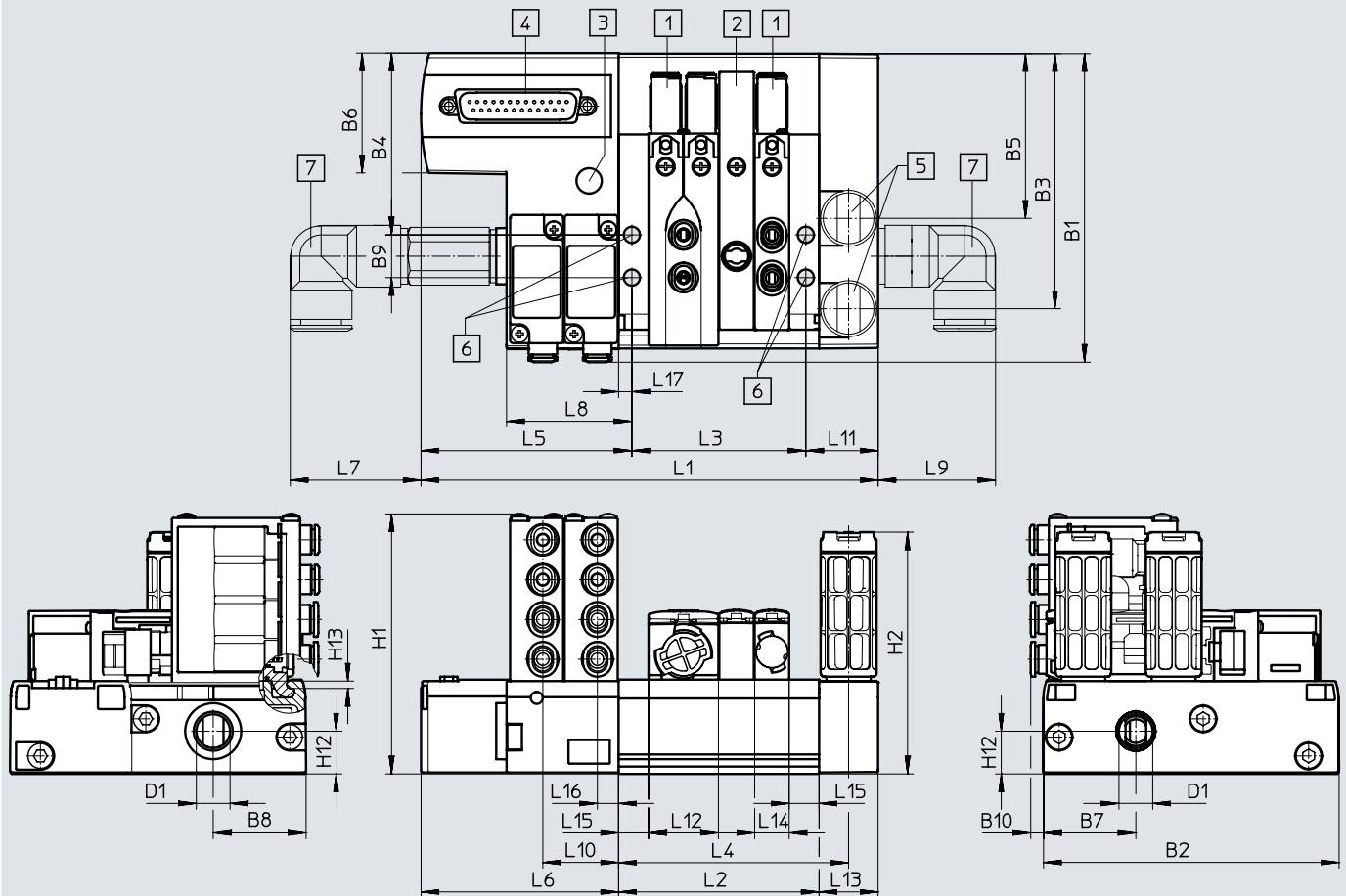

- [1] 5/2-way valve
- [2] Cover for vacant position
- [3] Silencer / threaded connection M5
- [4] Sub-D plug, 25-pin, or 44-pin with 21 or more solenoid coils
- [5] Silencer/threaded connection G1/4
- [6] Hole for wall mounting, \varnothing 5.5 mm
- [7] Fittings for air supply port
n Number of valve positions (2...35)

Type	L1	L2	L3	L4	L5	L6	L7	L8	L9	L10	L11	L12	L13	L14	L15	L16	L17
VTUB-12	$(n \times 12) + 107$ ± 1.5	$(n \times 12) + 20$	$(n \times 12) + 11$	78	71.5	67	32.4 ± 1	42.5	40 ± 1	25.7	24.5	23.7	20	11.7	10.2	7.2	4.5

Type	B1	B2	B3	B4	B5	B6	B7	B8	B9	B10	D1	H1	H2	H12	H13
VTUB-12	103 ± 2	100.4 ± 1.1	86.5	61.5	55.9	40.5	31.5	31.5	14.5	2.8	G1/4	88.2 ± 1	82 ± 1	14.5	2.5

Data sheet

Dimensions – Valve terminal with I-Port interface, CTEU bus node

Download CAD data → www.festo.com

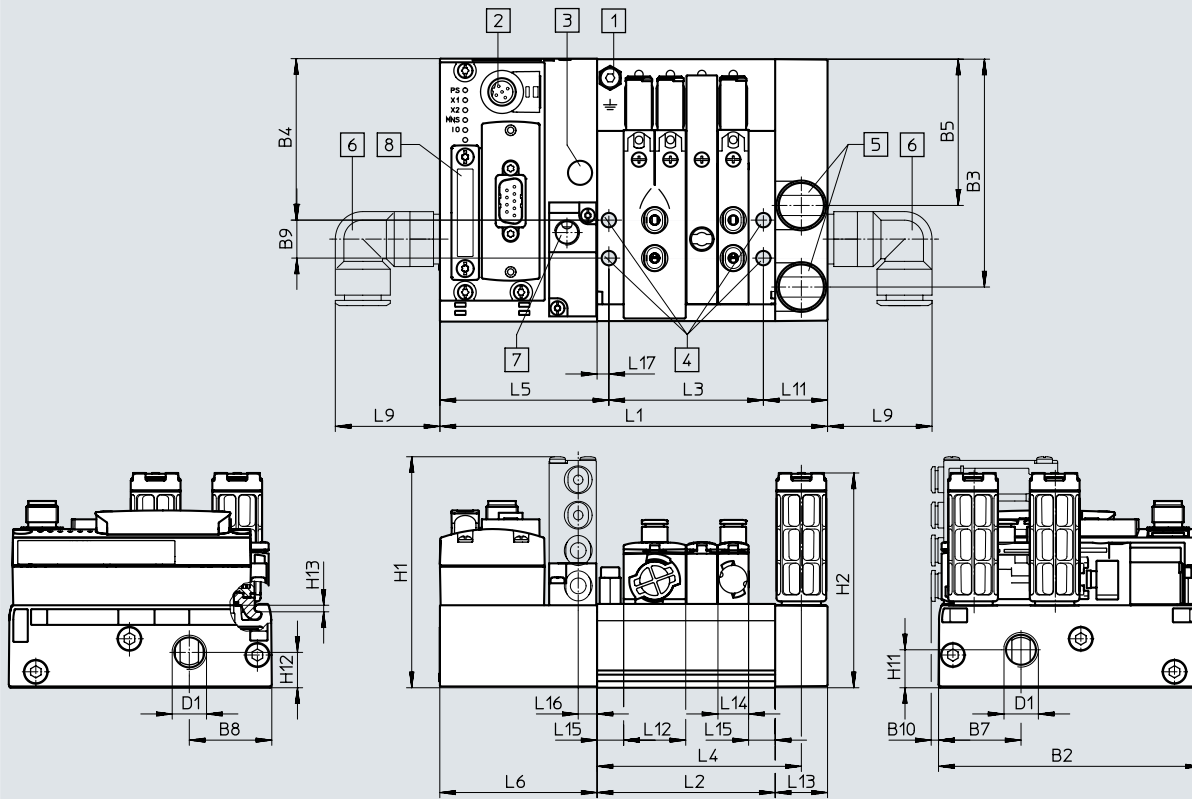

- [1] Earthing screw, M4
- [2] M12 plug, 5-pin
- [3] Silencer, threaded connection M5
- [4] Holes for mounting, \varnothing 5.5
- [5] Silencer, threaded connection G1/4
- [6] Fittings for air supply port
- [7] External pilot air 12/14, G1/8
- [8] Bus node CTEU
- n Number of valve positions (3...35)

Type	B2	B3	B4	B5	B7	B8	B9	B10	D1	H1	H2	H11	H12	H13
VTUB-12	100	87	61.5	55.9	31.3	31.5	14.5	3	G1/4	88.2	82	14.5	13.5	2.5

Type	L1	L2	L3	L4	L5	L6	L9	L11	L12	L13	L14	L15	L16	L17
VTUB-12	(nx12)+100	(nx12)+20	(nx12)+11	78	64.5	60	40	24.5	23.7	20	11.7	10.2	7.2	4.5

Data sheet

Dimensions – Sub-base for semi in-line valve (single solenoid)

Download CAD data → www.festo.com

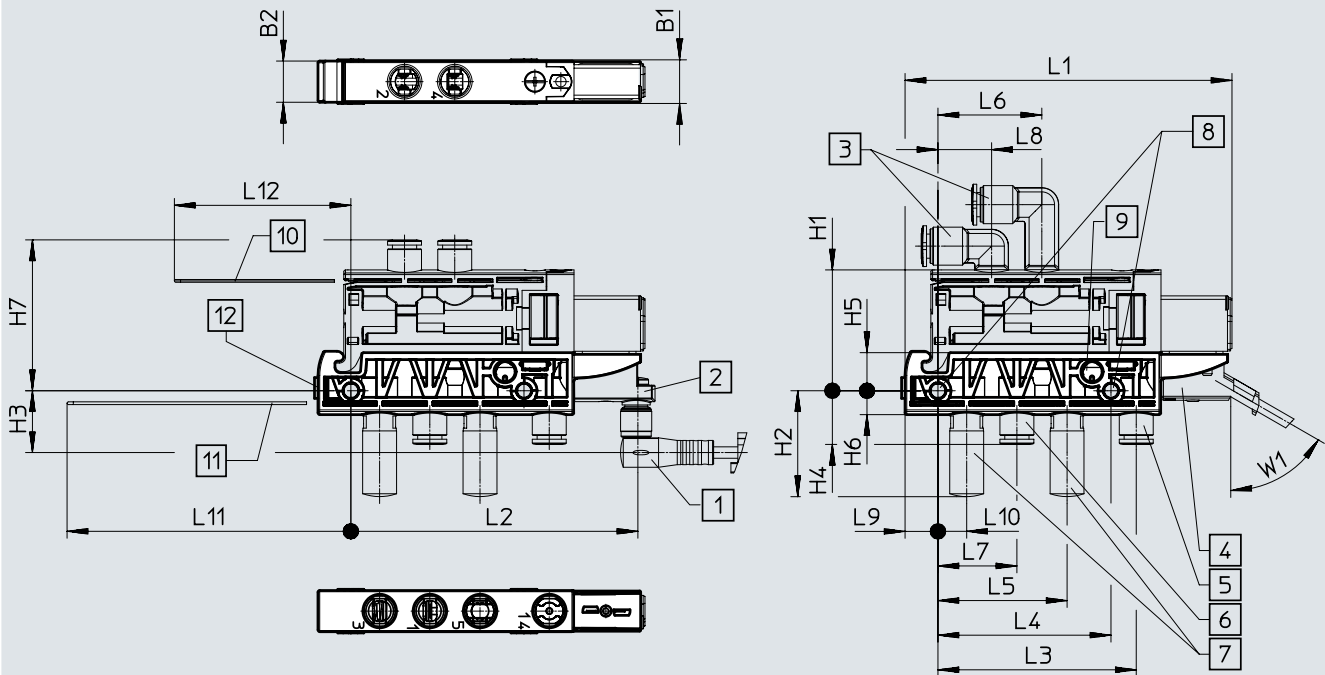

- [1] Connecting cable (optional)
- [2] Adapter M8x1 (optional)
- [3] Port 2, 4: Cartridge with push-in connector
- [4] Connecting cable NEBV or KMYZ (optional)
- [5] Port 12, 14: Cartridge with push-in connector (optional)
- [6] Port 1: Cartridge with push-in connector
- [7] Port 3, 5: Silencer AMTC-P-PC10 (optional)
- [8] Holes for M4 mounting
- [9] Exhaust air 82/84
- [10] Mounting space for spring clips for solenoid valve
- [11] Mounting space for spring clips for sub-base
- [12] Slot for inscription label IBS-6x10 (not included in scope of delivery)

Type	B1	B2	H1	H2	H3	H4	H5	H6	L1	L2	L3	L4	L5	L6	L7	L8	L9	L10	L11	L12	W1	
VABS-C8-12XB-QX-B	12.6	11.9	34.9	30.6	17.9	15.5	11	6.9	94.5	82.9	57.3	50	37.3	30	22.8	15.5	9.5	8.3	82	51	60°	
VABS-C8-12XB-QX																						

Data sheet

Dimensions – Sub-base for semi in-line valve (double solenoid)

Download CAD data → www.festo.com

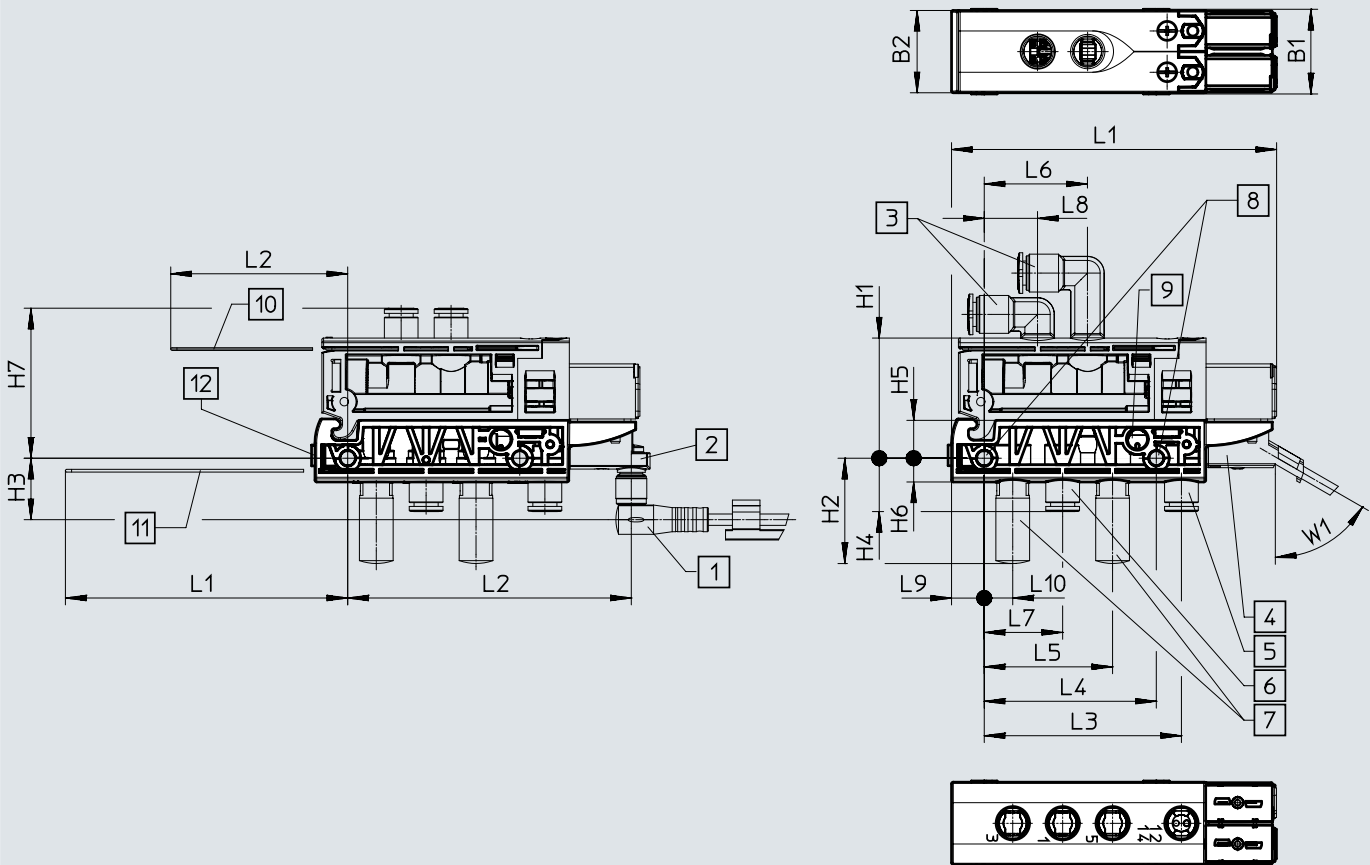

- [1] Connecting cable (optional)
- [2] Adapter M8x1 (optional)
- [3] Port 2, 4: Cartridge with push-in connector
- [4] Connecting cable NEBV or KMYZ (optional)
- [5] Port 12, 14: Cartridge with push-in connector (optional)
- [6] Port 1: Cartridge with push-in connector
- [7] Port 3, 5: Silencer AMTC-P-PC10 (optional)
- [8] Holes for M4 mounting
- [9] Exhaust air 82/84
- [10] Mounting space for spring clips for solenoid valve
- [11] Mounting space for spring clips for sub-base
- [12] Slot for inscription label IBS-6x10 (not included in scope of delivery)

Type	B1	B2	H1	H2	H3	H4	H5	H6	L1	L2	L3	L4	L5	L6	L7	L8	L9	L10	L11	L12	W1
VABS-C8-12XB-QX-DB	24.6	23.9	34.9	30.6	17.9	15.5	11	6.9	94.5	82.9	57.3	50	37.3	30	22.8	15.5	9.5	8.3	82	51	60°
VABS-C8-12XB-QX-D																					



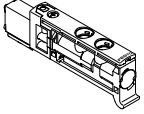
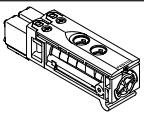
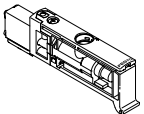
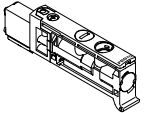
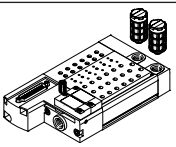
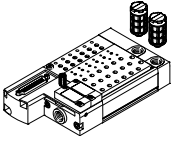

Accessories

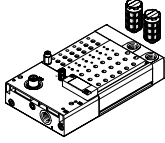
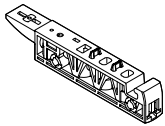
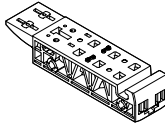
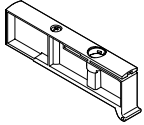
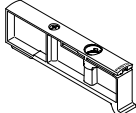
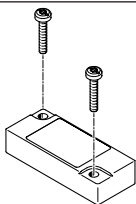
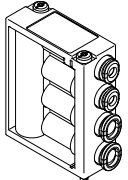
Ordering data		Code	Valve function	Part no.	Type
Solenoid valves					
	M	5/2-way valve, single solenoid, manual override non-detenting	Unducted solenoid exhaust air	557649	VUVB-ST12-M52-MZH-QX-1T1
			Ducted solenoid exhaust air	558369	VUVB-ST12-M52-MZH-QX-D-1T1
		5/2-way valve, single solenoid, manual override non-detenting/detenting	Unducted solenoid exhaust air	570908	VUVB-ST12-M52-MZD-QX-1T1
			Ducted solenoid exhaust air	570909	VUVB-ST12-M52-MZD-QX-D-1T1
	J	5/2-way valve, double solenoid, manual override non-detenting	Unducted solenoid exhaust air	557650	VUVB-ST12-B52-ZH-QX-1T1
			Ducted solenoid exhaust air	558370	VUVB-ST12-B52-ZH-QX-D-1T1
		5/2-way valve, double solenoid, manual override non-detenting/detenting	Unducted solenoid exhaust air	570910	VUVB-ST12-B52-ZD-QX-1T1
			Ducted solenoid exhaust air	570911	VUVB-ST12-B52-ZD-QX-D-1T1
	K	3/2-way valve, single solenoid, closed, manual override non-detenting	Unducted solenoid exhaust air	575997	VUVB-ST12-M32C-MZH-QX-1T1
			Ducted solenoid exhaust air	575998	VUVB-ST12-M32C-MZH-QX-D-1T1
		3/2-way valve, single solenoid, closed, manual override non-detenting/detenting	Unducted solenoid exhaust air	576001	VUVB-ST12-M32C-MZD-QX-1T1
			Ducted solenoid exhaust air	576002	VUVB-ST12-M32C-MZD-QX-D-1T1
	N	3/2-way valve, single solenoid, open, manual override non-detenting	Unducted solenoid exhaust air	575999	VUVB-ST12-M32U-MZH-QX-1T1
			Ducted solenoid exhaust air	576000	VUVB-ST12-M32U-MZH-QX-D-1T1
		3/2-way valve, single solenoid, open, manual override non-detenting/detenting	Unducted solenoid exhaust air	576003	VUVB-ST12-M32U-MZD-QX-1T1
			Ducted solenoid exhaust air	576004	VUVB-ST12-M32U-MZD-QX-D-1T1
Manifold rail					
	-	Multi-pin plug with Sub-D plug, 25-pin	2 valve positions	557651	VABM-C8-12E-G14-2-M1
			4 valve positions	557653	VABM-C8-12E-G14-4-M1
			6 valve positions	557655	VABM-C8-12E-G14-6-M1
			8 valve positions	557657	VABM-C8-12E-G14-8-M1
			10 valve positions	557659	VABM-C8-12E-G14-10-M1
			12 valve positions	557661	VABM-C8-12E-G14-12-M1
			14 valve positions	557663	VABM-C8-12E-G14-14-M1
			16 valve positions	557665	VABM-C8-12E-G14-16-M1
			18 valve positions	557667	VABM-C8-12E-G14-18-M1
			20 valve positions	557669	VABM-C8-12E-G14-20-M1
		Multi-pin plug with Sub-D plug, 44-pin	24 valve positions	557673	VABM-C8-12E-G14-24-M1
			28 valve positions	557677	VABM-C8-12E-G14-28-M1
			32 valve positions	557681	VABM-C8-12E-G14-32-M1
			35 valve positions	557684	VABM-C8-12E-G14-35-M1
	L	Multi-pin plug with Sub-D plug, 25-pin, LED signal status display	2 valve positions	1361863	VABM-C8-12E-G14-2-M1-L
			4 valve positions	1361865	VABM-C8-12E-G14-4-M1-L
			6 valve positions	1361867	VABM-C8-12E-G14-6-M1-L
			8 valve positions	1361868	VABM-C8-12E-G14-8-M1-L
			10 valve positions	1361869	VABM-C8-12E-G14-10-M1-L
			12 valve positions	1361870	VABM-C8-12E-G14-12-M1-L
			14 valve positions	1361871	VABM-C8-12E-G14-14-M1-L
			16 valve positions	1361873	VABM-C8-12E-G14-16-M1-L
			18 valve positions	1361874	VABM-C8-12E-G14-18-M1-L
			20 valve positions	1361875	VABM-C8-12E-G14-20-M1-L
		Multi-pin plug with Sub-D plug, 44-pin, LED signal status display	24 valve positions	1361876	VABM-C8-12E-G14-24-M1-L
			28 valve positions	1361877	VABM-C8-12E-G14-28-M1-L
			32 valve positions	1361878	VABM-C8-12E-G14-32-M1-L
			35 valve positions	1361879	VABM-C8-12E-G14-35-M1-L

Accessories

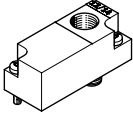
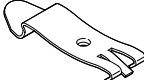
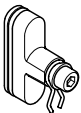
Ordering data		Code	Description	Part no.	Type
Manifold rail					
	PT/LK	Manifold rail with I-Port interface	4 valve positions	1247975	VABM-C8-12E-G14-4-PT-L
			6 valve positions	1247976	VABM-C8-12E-G14-6-PT-L
			8 valve positions	1247977	VABM-C8-12E-G14-8-PT-L
			10 valve positions	1247978	VABM-C8-12E-G14-10-PT-L
			12 valve positions	1247979	VABM-C8-12E-G14-12-PT-L
			14 valve positions	1247980	VABM-C8-12E-G14-14-PT-L
			16 valve positions	1247981	VABM-C8-12E-G14-16-PT-L
			18 valve positions	1247982	VABM-C8-12E-G14-18-PT-L
			20 valve positions	1247983	VABM-C8-12E-G14-20-PT-L
			24 valve positions	1247984	VABM-C8-12E-G14-24-PT-L
			28 valve positions	1247985	VABM-C8-12E-G14-28-PT-L
			32 valve positions	1247986	VABM-C8-12E-G14-32-PT-L
35 valve positions	1247987	VABM-C8-12E-G14-35-PT-L			
Sub-base for individual valve					
	-	For single solenoid valves	Internal pilot air supply	1236025	VABS-C8-12XB-QX-B
			External pilot air supply	1236027	VABS-C8-12XB-QX
	-	For double solenoid valves	Internal pilot air supply	1236028	VABS-C8-12XB-QX-DB
			External pilot air supply	1236029	VABS-C8-12XB-QX-D
Power supply module					
	S	For additional air supply or for supplying pressure zones (operating pressure 0 ... 0.8 MPa), pneumatic connection prepared for cartridge		1894888	VABF-C8-12-P3A5-QX
Cover plate					
	L	Cover plate for vacant valve position		562461	VABB-C8-12-ET
	-	Cover plate for compressed air distributor position		562460	VABB-C8-12-A
Compressed air distributor					
	AL	Push-in connector 4 mm		562457	VABF-C8-12-V1P4-Q4
	BL	Push-in connector 6 mm		562458	VABF-C8-12-V1P4-Q6
	CL	Push-in connector 4 and 6 mm		562459	VABF-C8-12-V1P4-Q4-Q6

Accessories



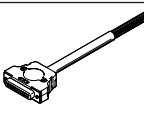
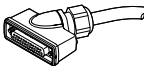

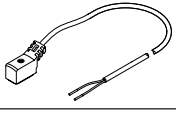
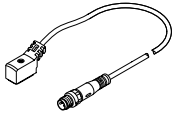
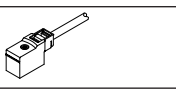
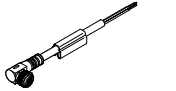
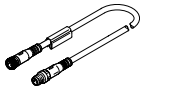

Ordering data					
	Code	Description	Packaging unit	Part no.	Type
Selector plate					
	SL	Pneumatic connection G1/8	1 piece	1210305	VABF-C8-12-P6-G18-Z
H-rail mounting					
	H	For mounting the valve terminal VTUB-12 on a standard H-rail TH 35-15 to EN 50022. (Use the following screws for mounting: M5x40 to DIN 912, 2 pieces)	2 pieces	2636436	VAME-T-M5
Separator					
	TP	For creating pressure zones (duct separation in duct 1)	1 piece	1877936	VABD-C8-P1
Blanking plug					
	-	For cartridge connection \varnothing 10 mm	1 piece	562243	QSPC10
	-	For thread G1/4	10 pieces	3569	B-1/4
	-	For thread G1/2	10 pieces	3571	B-1/2
Inscription labels					
	-	Inscription labels 6x10mm, 64 pieces, in frames	1 piece	18576	IBS-6x10

Ordering data					
	Code	Description	Cable length [m]	Part no.	Type
Connecting cable for multi-pin plug					
	M1	• Sub-D socket, straight, 15-pin, up to 12 coils, IP65/IP67 • Open cable end, 15-wire	2.5	538222	NEBV-S1G25-K-2.5-N-LE15
	M2		5	538223	NEBV-S1G25-K-5-N-LE15
	M3		10	538224	NEBV-S1G25-K-10-N-LE15
	M1	• Sub-D socket, straight, 25-pin, up to 20 coils, IP65/IP67 • Open cable end, 25-wire	2.5	538225	NEBV-S1G25-K-2.5-N-LE25
	M2		5	538226	NEBV-S1G25-K-5-N-LE25
	M3		10	538227	NEBV-S1G25-K-10-N-LE25
	M1	• Sub-D socket, straight, 44-pin, up to 35 coils, IP65/IP67 • Open cable end, 40-wire	2.5	565289	NEBV-S1G44-K-2.5-N-LE39
	M2		5	565290	NEBV-S1G44-K-5-N-LE39
	M3		10	565291	NEBV-S1G44-K-10-N-LE39
	M1L	• Sub-D socket, straight, 25-pin, up to 20 coils, IP40 • Open cable end, 25-wire	2.5	575417	NEBV-S1G25-K-2.5-N-LE25-S6
	M2L		5	575418	NEBV-S1G25-K-5-N-LE25-S6
	M3L		10	575419	NEBV-S1G25-K-10-N-LE25-S6
	M1L	• Sub-D socket, straight, 44-pin, up to 35 coils, IP40 • Open cable end, 44-wire	2.5	575113	NEBV-S1G44-K-2.5-N-LE44-S6
	M2L		5	575114	NEBV-S1G44-K-5-N-LE44-S6
	M3L		10	575115	NEBV-S1G44-K-10-N-LE44-S6
	MA1	• Sub-D socket, angled, 25-pin, up to 20 coils, IP65/IP67 • Open cable end, 25-wire	2.5	575423	NEBV-S1WA25-K-2.5-N-LE25-S9
	MA2		5	575424	NEBV-S1WA25-K-5-N-LE25-S9
	MA3		10	575425	NEBV-S1WA25-K-10-N-LE25-S9
	MA1	• Sub-D socket, angled, 44-pin, up to 35 coils, IP65/IP67 • Open cable end, 44-wire	2.5	575420	NEBV-S1WA44-K-2.5-N-LE44-S9
	MA2		5	575421	NEBV-S1WA44-K-5-N-LE44-S9
	MA3		10	575422	NEBV-S1WA44-K-10-N-LE44-S9

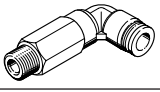

Accessories

Ordering data	Description	Cable length [m]	Part no.	Type	
Connecting cable for individual valve					
	<ul style="list-style-type: none"> • Angled socket, plug pattern ZC, 2-pin, with LED • Open cable end, 2-wire • Holding current reduction, protective circuit • IP65 	2.5	8047679	NEBV-Z4WA2L-R-E-2.5-N-LE2-S1	
		5	8047680	NEBV-Z4WA2L-R-E-5-N-LE2-S1	
		10	8047678	NEBV-Z4WA2L-R-E-10-N-LE2-S1	
	<ul style="list-style-type: none"> • Angled socket, plug pattern ZC, 2-pin, with LED • Straight plug M8x1, 3-pin • Holding current reduction, protective circuit • IP65 	0.5	8047683	NEBV-Z4WA2L-R-E-0.5-N-M8G3-S1	
		2.5	8047684	NEBV-Z4WA2L-R-E-2.5-N-M8G3-S1	
	<ul style="list-style-type: none"> • Angled socket, square design, 2-pin • Open cable end, 2-wire, no LED • IP40 	0.5	193690	KMYZ-4-24-0.5-B	
		2.5	193691	KMYZ-4-24-2.5-B	
Connecting cable					
	Open cable end, 3-wire	Straight socket, M8x1, 3-pin	2.5	541333	NEBU-M8G3-K-2.5-LE3
			5	541334	NEBU-M8G3-K-5-LE3
			10	541332	NEBU-M8G3-K-10-LE3
		Socket M8x1, angled, 3-pin	2.5	159420	SIM-M8-3GD-2.5-PU
			5	159421	SIM-M8-3GD-5-PU
			10	192964	SIM-M8-3GD-10-PU
	Open cable end, 4-wire	Straight socket, M8x1, 4-pin	2.5	541338	NEBU-M8W3-K-2.5-LE3
			5	541341	NEBU-M8W3-K-5-LE3
			10	541335	NEBU-M8W3-K-10-LE3
			2.5	159422	SIM-M8-3WD-2.5-PU
		Socket M8x1, angled, 4-pin	5	159423	SIM-M8-3WD-5-PU
			10	192965	SIM-M8-3WD-10-PU
			2.5	541342	NEBU-M8G4-K-2.5-LE4
			5	541343	NEBU-M8G4-K-5-LE4
Straight plug, 3-pin	Straight socket, M8x1, 3-pin	2.5	158960	SIM-M8-4GD-2.5-PU	
		5	158961	SIM-M8-4GD-5-PU	
		10	158963	SIM-M8-4WD-5-PU	
	Socket M8x1, angled, 4-pin	2.5	541344	NEBU-M8W4-K-2.5-LE4	
		5	541345	NEBU-M8W4-K-5-LE4	
		2.5	158962	SIM-M8-4WD-2.5-PU	
	Straight plug, 3-pin	Straight socket, M8x1, 3-pin	5	158963	SIM-M8-4WD-5-PU
			0.5	541346	NEBU-M8G3-K-0.5-M8G3
			1	541347	NEBU-M8G3-K-1-M8G3
			2.5	541348	NEBU-M8G3-K-2.5-M8G3
	Straight plug, 4-pin	Straight socket, M8x1, 3-pin	5	541349	NEBU-M8G3-K-5-M8G3
			10	569844	NEBU-M8G3-K-10-M8G3
			2.5	554037	NEBU-M8G3-K-2.5-M8G4
		Straight socket, M8x1, 4-pin	2.5	554035	NEBU-M8G4-K-2.5-M8G4

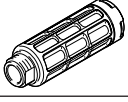
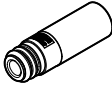
Accessories

Ordering data	Description	Tubing O.D.	Packaging unit	Part no.	Type
Push-in fitting Data sheets → Internet: quick star					
	With sealing ring Connection G1/4	8 mm	10 pieces	186099	QS-G1/4-8
		10 mm	10 pieces	186101	QS-G1/4-10
		12 mm	10 pieces	186350	QS-G1/4-12
Push-in L-fitting Data sheets → Internet: quick star					
	With sealing ring Connection G1/4	8 mm	10 pieces	186120	QSL-G1/4-8
		10 mm	10 pieces	186122	QSL-G1/4-10
		12 mm	10 pieces	186351	QSL-G1/4-12
Push-in L-fitting, long Data sheets → Internet: quick star					
	With sealing ring Connection G1/4	8 mm	10 pieces	186131	QSL-G1/4-8
		10 mm	10 pieces	186133	QSL-G1/4-10
		12 mm	10 pieces	132596	QSL-G1/4-12
Cartridge with push-in connector					
	Straight Connection Ø 10 mm	4 mm	10 pieces	172972	QSP10-4
		6 mm	10 pieces	172973	QSP10-6
	L-shape Connection Ø 10 mm	4 mm	10 pieces	132601	QSPLK10-4
		6 mm	10 pieces	132602	QSPLK10-6
	L-shape, long Connection Ø 10 mm	4 mm	10 pieces	132603	QSPLLK10-4
		6 mm	10 pieces	132604	QSPLLK10-6
Silencer Data sheets → Internet: u					
	For thread G1/4		1 piece	2316	U-1/4
	For individual sub-base, for cartridge connection Ø 10 mm		1 piece	1224460	AMTC-P-P10

Accessories

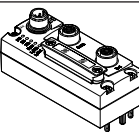
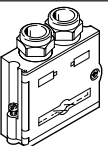
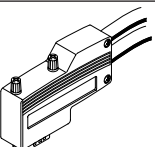
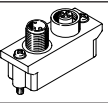
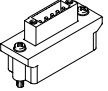
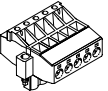
Ordering data		Code	Description	Part no.	Type
Adapter M8x1					
	-	Plug M8x1 with LED	3-pin	571686	VAVE-C8-1R8
			4-pin	573194	VAVE-C8-1R1
Connection technology for I-Port interface/IO-Link					
	XM	T-adapter M12, 5-pin, for IO-Link and load supply		171175	FB-TA-M12-5POL
	XN	Straight plug, M12, 5-pin for T-adapter FB-TA		175487	SEA-M12-5GS-PG7
Ordering data – CTEU				Part no.	Type
Bus node					
	CANopen bus node			570038	CTEUCO
	DeviceNet bus node			570039	CTEU-DN
	EtherCAT bus node			572556	CTEU-EC
	CC-Link bus node			1544198	CTEU-CC
	PROFIBUS bus node			570040	CTEU-PB
	AS-Interface bus node			572555	CTEU-AS
	PROFINET bus node			2201471	CTEU-PN
	EtherNet/IP bus node			2798071	CTEU-EP
	VARAN bus node			8087559	CTEU-VN
Interface for installation system CPI			2149714	CTEU-CP	
Bus connection					
	Sub-D plug, straight	For DeviceNet/CANopen	532219	FBS-SUB-9-BU-2x5POL-B	
		For CC-Link	532220	FBS-SUB-9-GS-2x4POL-B	
		For PROFIBUS	532216	FBS-SUB-9-GS-DP-B	
	Sub-D plug, angled	For CANopen, 9-pin	533783	FBS-SUB-9-WS-CO-K	
		For PROFIBUS, 9-pin	533780	FBS-SUB-9-WS-PB-K	
	M12x1, 5-pin	A-coded, for DeviceNet/CANopen	525632	FBA-2-M12-5POL	
		B-coded, for PROFIBUS	533118	FBA-2-M12-5POL-RK	
	For 5-pin terminal strip for DeviceNet/CANopen		525634	FBA-1-SL-5POL	
	Terminal strip, 5-pin, for DeviceNet/CANopen		525635	FBSD-KL-2x5POL	

Accessories

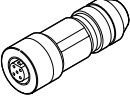
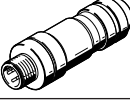
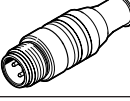
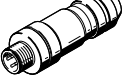
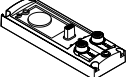
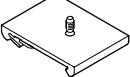
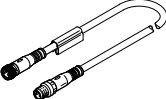
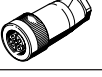
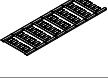
Ordering data – CTEU		Part no.	Type	
Bus connection				
	Socket, M12x1, 5-pin, for DeviceNet/CANopen	18324	FBSD-GD-9-5POL	
	Plug, M12x1, 5-pin, for DeviceNet/CANopen	175380	FBS-M12-5GS-PG9	
	Straight socket, M12x1, 5-pin, for assembling a connecting cable compatible with FBA-2-M12-5POL-RK for PROFIBUS	1067905	NECU-M-B12G5-C2-PB	
	Straight plug, M12x1, 5-pin, for assembling a connecting cable compatible with FBA-2-M12-5POL-RK for PROFIBUS	1066354	NECU-M-S-B12G5-C2-PB	
	Terminating resistor, M12, B-coded for PROFIBUS	1072128	CACR-S-B12G5-220-PB	
	Plug M12x1, 4-pin, D-coded for EtherCAT	543109	NECU-M-S-D12G4-C2-ET	
Electrical connection block				
	For connecting a second device with I-Port interface	570042	CAPC-F1-E-M12	
H-rail mounting				
	For electrical connection block CAPC	570043	CAFM-F1-H	
Connecting cables				
	<ul style="list-style-type: none"> • Straight socket, M12x1, 5-pin • Straight plug, M12x1, 5-pin • Nominal conductor cross section 1 mm² 	5 m	574321	NEBU-M12G5-E-5-Q8N-M12G5
		7.5 m	574322	NEBU-M12G5-E-7.5-Q8N-M12G5
		10 m	574323	NEBU-M12G5-E-10-Q8N-M12G5
	<ul style="list-style-type: none"> • Angled socket, M12x1, 5-pin • Angled plug, M12x1, 5-pin 	0.5 m	570733	NEBU-M12W5-K-0.5-M12W5
		2 m	570734	NEBU-M12W5-K-2-M12W5
		0.5 m	8003617	NEBU-M12G5-K-0.5-M12W5
2 m	8003618	NEBU-M12G5-K-2-M12W5		
Plug socket				
	For power supply, M12x1, 5-pin, B-coded for CANopen/DeviceNet	538999	NTSD-GD-9-M12-5POL-RK	
	For power supply, M12x1, 5-pin for CC-Link, PROFIBUS, EtherCAT	18324	FBSD-GD-9-5POL	
Inscription label				
	For bus node, pack of 200 (5 frames each with 40 labels)	565306	ASLR-C-E4	

Festo - Your Partner in Automation



1 Festo Inc.
5300 Explorer Drive
Mississauga, ON L4W 5G4
Canada

Festo Customer Interaction Center
Tel: 1 877 463 3786
Fax: 1 877 393 3786
Email: customer.service.ca@festo.com



2 Festo Pneumatic
Av. Ceylán 3,
Col. Tequesquináhuac
54020 Tlalnepantla,
Estado de México

Multinational Contact Center
01 800 337 8669
ventas.mexico@festo.com



3 Festo Corporation
1377 Motor Parkway
Suite 310
Islandia, NY 11749

Festo Customer Interaction Center
1 800 993 3786
1 800 963 3786
customer.service.us@festo.com



4 Regional Service Center
7777 Columbia Road
Mason, OH 45040

Connect with us



www.festo.com/socialmedia



www.festo.com

Subject to change