

Pressure and vacuum switches PEV/VPEV

FESTO

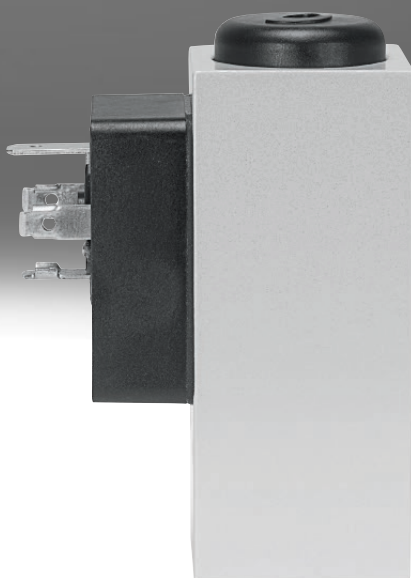
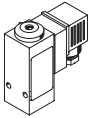
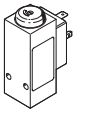
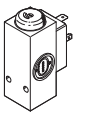
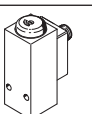
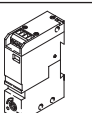
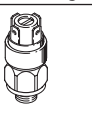
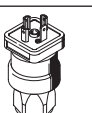
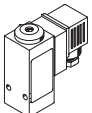
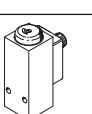
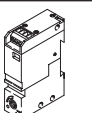

Product range overview

Function	Design	Type	Operating pressure [bar]	Pneumatic connection	Electrical connection	Max. switching output voltage		→ Page
						[V DC]	[V AC]	
Mechanical pressure switch	Mounting via retaining screws							
		PEV	1 ... 12	G1/4	Plug, type A ¹⁾	125	250	3
		PEV	1 ... 12	G1/4	Plug, type A	125	250	3
		PEV Visual scale for pressure adjustment	1 ... 12	G1/4	Plug, type A	125	250	3
		PEV	1 ... 12	G1/4	M12x1 plug, 4-pin	48	48	3
	H-rail mounting							
		PEV-W	0 ... 8	M5	M8x1 plug, 4-pin	30	–	11
		PEV-W	0 ... 8	M5	Screw terminal, 4-pin	30	–	11
	Mounting via screw-in thread							
		PEV-SW27	1 ... 10	G1/4	For plug socket PEV-1/4-A-WD	250	250	16
		PEV-SW27	1 ... 10	G1/4	For plug socket PEV-1/4-WD-LED...	250	250	16
	Mechanical vacuum switch	Mounting via retaining screws						
		VPEV	-1 ... +1.6	G1/8	Plug, type A ¹⁾	125	250	3
		VPEV	-1 ... +1.6	G1/8	M12x1 plug, 4-pin	48	48	3
H-rail mounting								
		VPEV-W	-1 ... 0	M5	M8x1 plug, 4-pin	30	–	11
		VPEV-W	-1 ... 0	M5	Screw terminal, 4-pin	30	–	11

1) Plug socket included in the scope of delivery

Peripherals overview – PEV/VPEV with through-hole

PEV

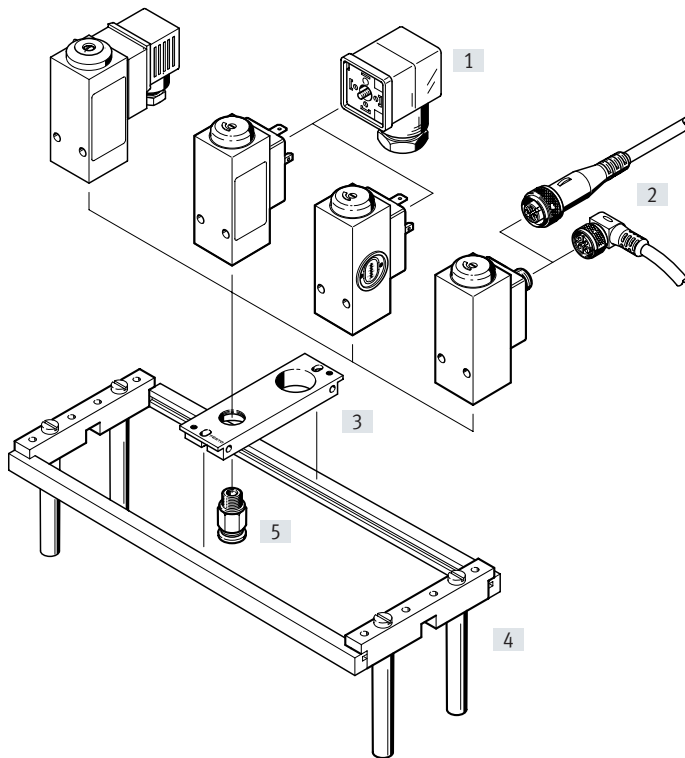

VPEV

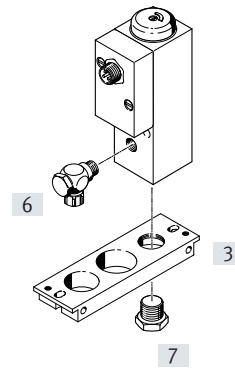

 **Note**

The vacuum switch VPEV can be used as a pressure switch by repositioning the plug screw supplied from the pressure supply port to the vacuum port.

Mounting attachments and accessories		→ Page/Internet
[1]	Angled plug socket with switching status indication PEV	20
	Plug socket without switching status indication MSSD	25
[2]	Connecting cable NEBU-M12	25
[3]	Mounting plate APL	23

Mounting attachments and accessories		→ Page/Internet
[4]	Mounting frame NRRQ	24
[5]	Push-in fitting QS	qs
[6]	Quick connector CK-1/8, LCK-1/8	ck
[7]	Plug screw VPEV-1/8 (included in the scope of delivery of VPEV)	–

Type codes – PEV/VPEV with through-hole

001	Series	
PEV	Pressure switch	
VPEV	Vacuum switch	

002	Pneumatic connection	
1/8	G1/8	
1/4	G1/4	

003	Generation	
	None	
B	Series B	

004	Electrical connection	
	Plug, type A, square design, to EN 175301-803	
M12	Plug M12x1, 4-pin, round design, to EN 60947-5-2	

005	Setting options	
	None	
SC	Scale for pressure setting	

006	Plug socket	
	Included in the scope of delivery	
OD	Not included in the scope of delivery	

Datasheet – PEV/VPEV with through-hole

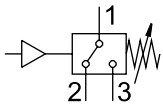
 Function
 PEV/VPEV

PEV/VPEV...-M12

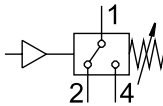
General technical data

Type	PEV-1/4-B(-OD)	PEV-1/4-SC-OD	PEV-1/4-B-M12	VPEV-1/8	VPEV-1/8-M12
General					
Type of mounting	With through-hole				
Mounting position	Any				
Pneumatic connection	G1/4			G1/8	
Input signal/measuring element					
Measured variable	Relative pressure				
Measurement method	Pneumatic/electric pressure transducer				
Pressure measuring range [bar]	–	With setting scale	–	–	–
				–1 ... +1.6	

Electrical data

Type	PEV-1/4-B(-OD)	PEV-1/4-SC-OD	PEV-1/4-B-M12	VPEV-1/8	VPEV-1/8-M12
Switching output					
Switching element function	Changeover switch				
Max. switching frequency [Hz]	3				
Max. switching output voltage	[V AC]	250	48	250	48
	[V DC]	125	48	125	48
Max. output current [mA]	5000		4000	5000	4000
Minimum load current	[mA]	1 (at 24 V)			
	[mA]	10 (at 10 V)			
	[mA]	100 (at 5 V)			
Electronics					
Utilisation category for inductive load	AC-14				
	DC-13				
Utilisation category for resistive load	AC-12				
	DC-12				
Electromechanics					
Electrical connection	Plug, type A, square design, to EN 175301-803		M12x1 plug, 4-pin, round design, to EN 60947-5-2	Plug, type A, square design, to EN 175301-803	M12x1 plug, 4-pin, round design, to EN 60947-5-2

Pin assignment

Plug, type A	Pin	Description	M12x1 plug, 4-pin	Pin	Description
	1	Operating voltage		1	Operating voltage
	2	N/C		2	N/C
	3	N/O		3	Not assigned
	4	Earthing		4	N/O

Datasheet – PEV/VPEV with through-hole

Display/operation					
Type	PEV-1/4-B(-OD)	PEV-1/4-SC-OD	PEV-1/4-B-M12	VPEV-1/8	VPEV-1/8-M12
Switching output					
Switching status indication	Yellow ¹⁾ LED			Yellow LED	
Threshold-value setting range [bar]	1 ... 12			-0.95 ... -0.2	
Threshold-value setting range after modification [bar]	-			0.16 ... 1.6	

1) PEV-1/4-B-OD

Operating and environmental conditions					
	PEV-1/4-B(-OD)	PEV-1/4-SC-OD	PEV-1/4-B-M12	VPEV-1/8	VPEV-1/8-M12
Operating pressure [bar]	1 ... 12			-1 ... +1.6	
	[MPa] 0.1 ... 1.2			-0.1 ... +0.16	
Operating medium	Compressed air to ISO 8573-1:2010 [7:-:-]			Compressed air to ISO 8573-1:2010 [7:4:4]	
	Water			-	
Note on the operating/pilot medium	Lubricated operation possible (in which case lubrication will always be required)				
Temperature of medium [°C]	-20 ... +80				
Ambient temperature [°C]	-20 ... +80				
Conforms to	EN 60947-5-1				
Certification	-	-	c UL us - Recognized (OL)	-	c UL us - Recognized (OL)
	CCC				
CE marking (see declaration of conformity) ¹⁾	To EU Low Voltage Directive				
UKCA marking (see declaration of conformity) ¹⁾	To UK regulations for electrical equipment				
Degree of protection	IP65				
Corrosion resistance class CRC ²⁾	2 - Moderate corrosion stress				

1) More information: www.festo.com/catalogue/pev → Support/Downloads.2) More information www.festo.com/x/topic/crc

Materials					
	PEV-1/4-B(-OD)	PEV-1/4-SC-OD	PEV-1/4-B-M12	VPEV-1/8	VPEV-1/8-M12
Information on housing materials	Die-cast aluminium			Wrought aluminium alloy	
Information on switching contact materials	Silver				
Note on materials	RoHS-compliant				
LABS (PWIS) conformity	VDMA24364-B1/B2-L				

Datasheet – PEV/VPEV with through-hole

Dimensions – Pressure switch

Download CAD data → www.festo.com

PEV-1/4-B

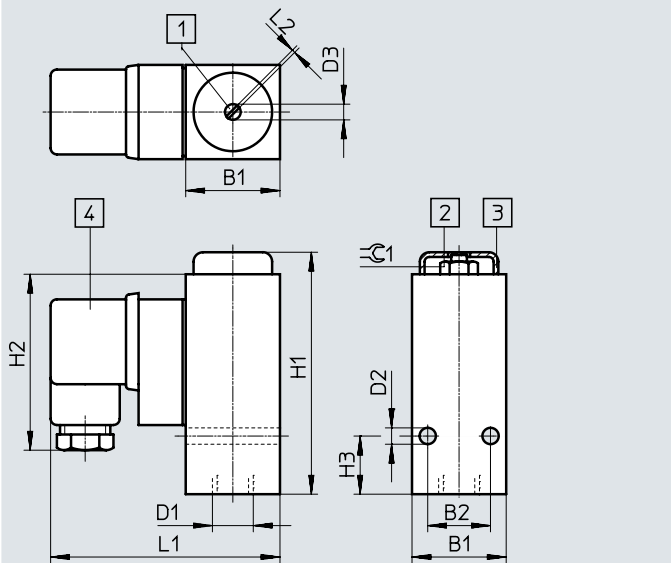

- [1] Switching point adjusting screw
- [2] Hex nut for adjusting the hysteresis (under protective cap)
- [3] Protective cap
- [4] Push-in connector M16x1.5 to EN 175301-803-A, choice of cable outlet by turning socket insert 4x90°

PEV-1/4-B-OD

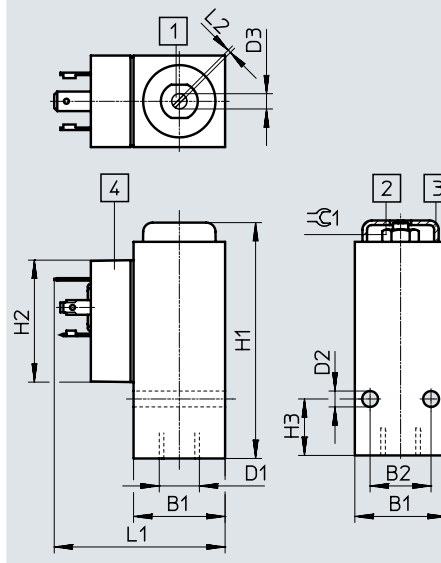

- [1] Switching point adjusting screw
- [2] Hex nut for adjusting the hysteresis (under protective cap)
- [3] Protective cap
- [4] Push-in connector suitable for plug socket M16x1.5 to EN 175301-803-A

Type	B1	B2	D1	D2 ∅	D3	H1	H2	H3	L1	L2	⊕1
PEV-1/4-B	±0.2	±0.1	G1/4	±0.2	min. 5	±0.6	56	±0.5	78	±0.2	11
PEV-1/4-B-OD							40		56		

Dimensions – Pressure switch

Download CAD data → www.festo.com

PEV-1/4-SC-OD

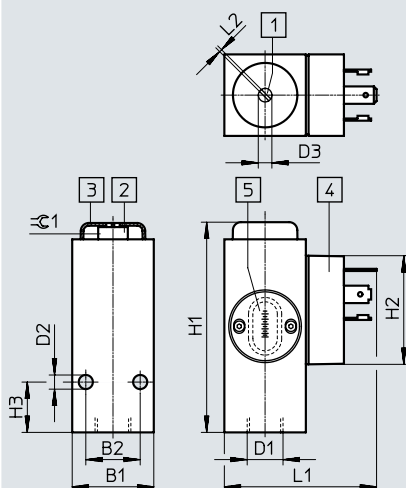

- [1] Switching point adjusting screw
- [2] Hex nut for adjusting the hysteresis (under protective cap)
- [3] Protective cap
- [4] Push-in connector suitable for plug socket M16x1.5 to EN 175301-803-A
- [5] Scale for reading off the set switching pressure

Type	B1	B2	D1	D2 ∅	D3	H1	H2	H3	L1	L2	⊕1
PEV-1/4-SC-OD	±0.2	±0.1	G1/4	±0.2	min. 5	±0.6	40	±0.5	56	±0.2	11

Datasheet – PEV/VPEV with through-hole

Dimensions – Pressure switch

Download CAD data → www.festo.com

PEV-1/4-B-M12

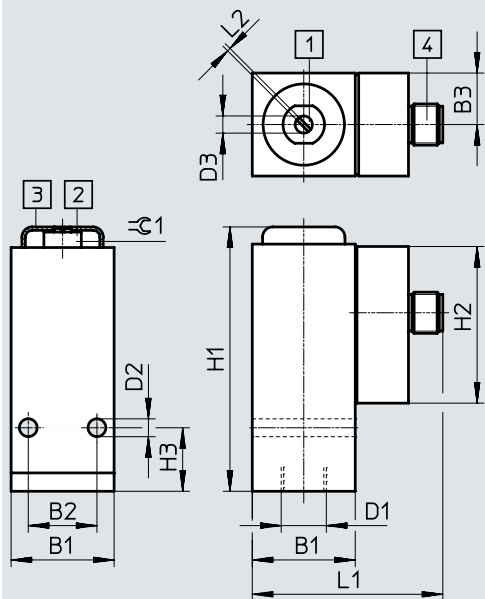

- [1] Switching point adjusting screw
- [2] Hex nut for adjusting the hysteresis (under protective cap)
- [3] Protective cap
- [4] Plug pattern for plug connector M12x1 to EN 60947-5-2

Type	B1	B2	B3	D1	D2 ∅	D3	H1	H2	H3	L1	L2	≡C1
	±0.2	±0.1			±0.2		±0.6		±0.5		±0.2	
PEV-1/4-B-M12	30	20	12.5	G1/4	5.2	min. 5	77.3	40	18.5	55.4	1	11

Datasheet – PEV/VPEV with through-hole

Dimensions – Vacuum switch

Download CAD data → www.festo.com

VPEV-1/8

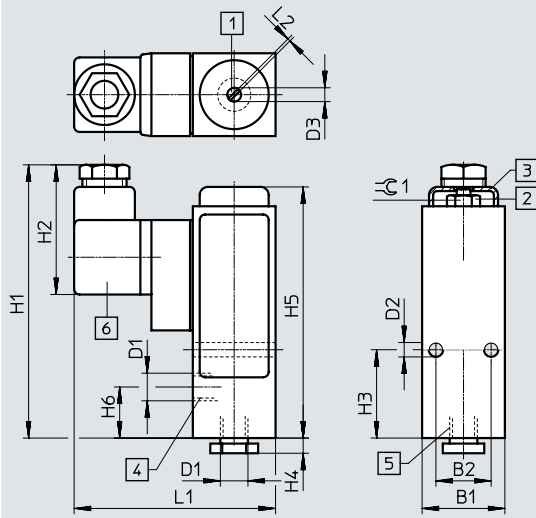

- [1] Switching point adjusting screw
- [2] Hex nut for adjusting the hysteresis (under protective cap)
- [3] Protective cap
- [4] Vacuum port
- [5] Supply port with plug screw
- [6] Push-in connector M16x1.5 to EN 175301-803-A, choice of cable outlet by turning socket insert 4x90°

VPEV-1/8-M12

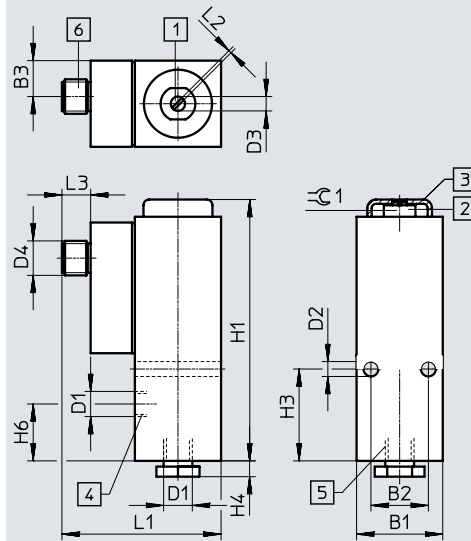

- [1] Switching point adjusting screw
- [2] Hex nut for adjusting the hysteresis (under protective cap)
- [3] Protective cap
- [4] Vacuum port
- [5] Supply port with plug screw
- [6] Plug pattern for plug connector to EN 60947-5-2

Type	B1	B2	B3	D1	D2	D3	D4	H1	H2	H3	H4	H5	H6	L1	L2	L3	≅G1
	±0.2	±0.1	-0.1		∅ ±0.2					±0.1					±0.2		
VPEV-1/8	30	20	-	G1/8	5.2	min. 5	-	98	48	32	5.5	91	18.5	78	1	-	11
VPEV-1/8-M12			12.5				M12x1	91	-			-		55.4		10	

Datasheet – PEV/VPEV with through-hole

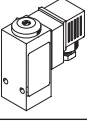
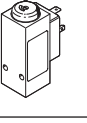
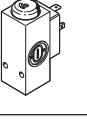
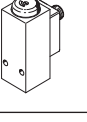
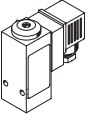
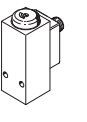
Ordering data					
	Pneumatic connection	Electrical connection	Product weight [g]	Part no.	Type
Pressure switch					
	G1/4	Plug, type A, square design, to EN 175301-803 Plug socket included in the scope of delivery	194	10773	PEV-1/4-B
	G1/4	Plug, type A, square design, to EN 175301-803	194	175250	PEV-1/4-B-OD
	G1/4	Plug, type A, square design, to EN 175301-803	144	161760	PEV-1/4-SC-OD
	G1/4	M12x1 plug, 4-pin, round design, to EN 60947-5-2	194	192488	PEV-1/4-B-M12
Vacuum switch					
	G1/8	Plug, type A, square design, to EN 175301-803 Plug socket included in the scope of delivery	240	150261	VPEV-1/8
	G1/8	M12x1 plug, 4-pin, round design, to EN 60947-5-2	194	192489	VPEV-1/8-M12

Peripherals overview – PEV-W/VPEV-W for H-rail mounting

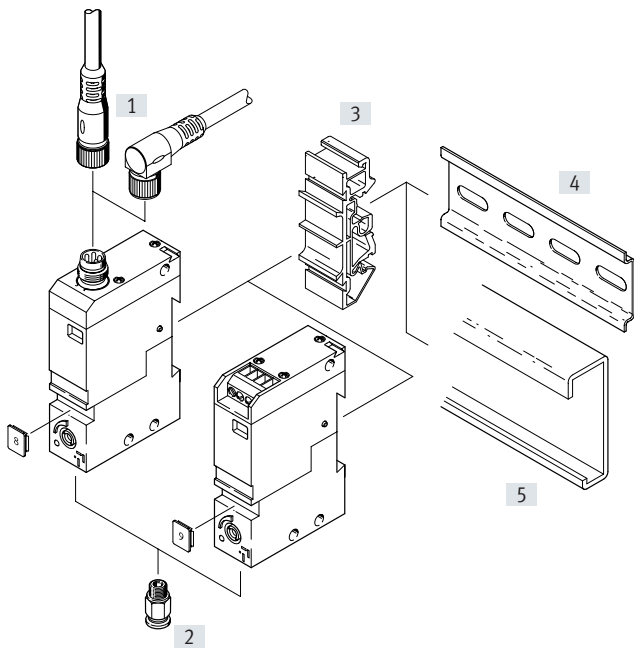

Mounting attachments and accessories		→ Page/Internet
[1]	Connecting cable NEBU-M8	25
[2]	Push-in fitting QSM-M5	qsm
[3]	Mounting latch PENV	25
[4]	DIN mounting rail NRH to EN 60715	25
[5]	DIN mounting rail NRC to EN 50035	25

Type codes – PEV-W/VPEV-W for H-rail mounting

001	Series	
PEV-W	Pressure switch	
VPEV-W	Vacuum switch	

002	Electrical connection	
S	Plug M8x1, 4-pin	
KL	Screw terminal, 4-pin	

003	Switching status indication	
LED	Yellow LED	

004	Type of mounting	
GH	With H-rail or with through-hole	

Datasheet – PEV-W/VPEV-W for H-rail mounting

Function

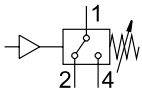

General technical data

Type	PEV-W	VPEV-W
General		
Pneumatic connection	M5	
Type of mounting	With through-hole, with H-rail With H-rail	
Mounting position	Any	
Input signal/measuring element		
Measured variable	Relative pressure	
Measurement method	Pneumatic/electric pressure transducer	
Pressure measuring range [bar]	2 ... 8	-0.8 ... -0.25

Electrical data

Type	PEV-W-S	PEV-W-KL	VPEV-W-S	VPEV-W-KL
Switching output				
Switching element function	Changeover switch			
Hysteresis [bar]	0.5 ... 2		0.08 ... 0.25	
Max. switching frequency [Hz]	3			
Max. output current [mA]	2500			
Operating voltage range [V DC]	10 ... 30			
Electromechanics				
Electrical connection	M8x1 plug, 4-pin	Screw terminal, 4-pin	M8x1 plug, 4-pin	Screw terminal, 4-pin

Pin assignment

M8x1 plug, 4-pin	Pin	Description	Screw terminal, 4-pin	Pin	Description
	1	+ (-)		1	+ (-)
	2	N/C		2	N/C
	3	- (+)		3	- (+)
	4	N/O		4	N/O

Display/operation

Type	PEV-W	VPEV-W
Switching output		
Switching status indication	Yellow LED	
Threshold-value setting range [bar]	2 ... 8	-0.8 ... -0.25

Datasheet – PEV-W/VPEV-W for H-rail mounting

Operating and environmental conditions				
Type	PEV-W-S	PEV-W-KL	VPEV-W-S	VPEV-W-KL
Operating pressure [bar]	0 ... +8		-1 ... 0	
Operating medium	Compressed air to ISO 8573-1:2010 [7:-:-]			
Max. overload pressure [bar]	20		8	
Note on the operating/pilot medium	Lubricated operation possible (in which case lubrication will always be required)			
Temperature of medium [°C]	0 ... +60			
Ambient temperature [°C]	0 ... +60			
Certification	RCM compliance mark			
CE marking (see declaration of conformity) ¹⁾	To EU EMC Directive To EU RoHS Directive			
UKCA marking (see declaration of conformity) ¹⁾	To UK EMC regulations To UK RoHS regulations			
Degree of protection	IP65	IP20	IP65	IP20
Corrosion resistance class KBK ²⁾	2			

- 1) More information: www.festo.com/catalogue/pev-w → Support/Downloads.
If the devices are subject to usage restrictions in residential, commercial or light-industrial environments, further measures for the reduction of the emitted interference may be necessary.
In this case, the signal line length needs to be < 30 m.
- 2) More information www.festo.com/x/topic/crc

Materials	
Information on housing materials	PA, PET, POM
Diaphragm material	NBR
Note on materials	RoHS-compliant
LABS (PWIS) conformity	VDMA24364 zone III

Datasheet – PEV-W/VPEV-W for H-rail mounting

Dimensions

PEV-W-S, VPEV-W-S

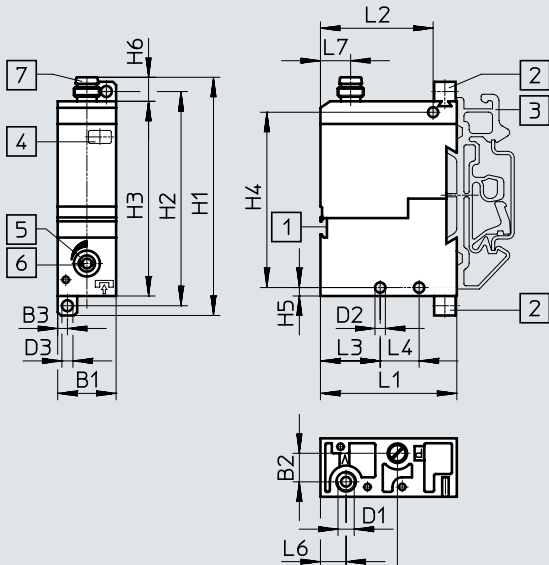

- [1] Slot for inscription label
- [2] Foot mounting (included in the scope of delivery)
- [3] Clamping foot for G/H rail
- [4] Switching status indication, yellow
- [5] Switching point adjusting screw
- [6] Manual override
- [7] Integrated plug, fits plug sockets NEBU

Download CAD data → www.festo.com

PEV-W-KL, VPEV-W-KL

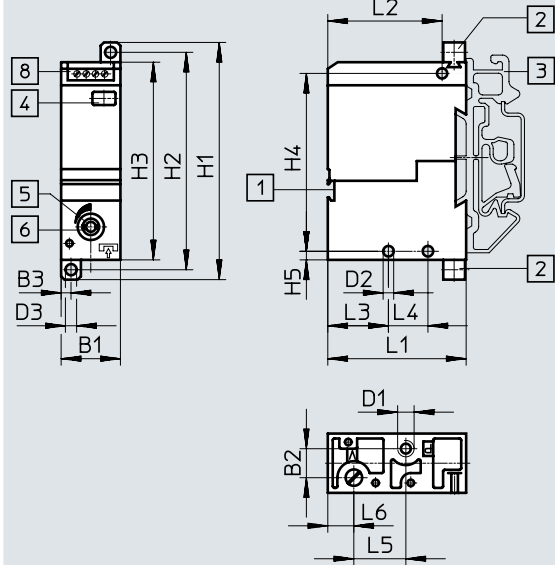

- [1] Slot for inscription label
- [2] Foot mounting (included in the scope of delivery)
- [3] Clamping foot for G/H rail
- [4] Switching status indication, yellow
- [5] Switching point adjusting screw
- [6] Manual override
- [7] Cable terminals

Type	B1	B2	B3	D1	D2 ∅	D3	H1	H2	H3	H4	H5	H6	L1	L2	L3	L4	L5	L6	L7
PEV-W-S, VPEV-W-S	18	8.8	3	M5	3.2	3.4	73.4	66	60	54	2.6	7.4	42	34.7	18.4	12	15.8	7.9	9.3
PEV-W-KL, VPEV-W-KL							72					-							-

Ordering data

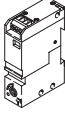
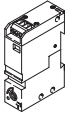
	Pneumatic connection	Electrical connection	Product weight [g]	Part no.	Type
Pressure switch					
	M5	M8x1 plug, 4-pin	56	152616	PEV-W-S-LED-GH
		Screw terminal, 4-pin	56	152618	PEV-W-KL-LED-GH
Vacuum switch					
	M5	M8x1 plug, 4-pin	56	152617	VPEV-W-S-LED-GH
		Screw terminal, 4-pin	56	152619	VPEV-W-KL-LED-GH

Peripherals overview – Pressure switch PEV-SW27, screw-in

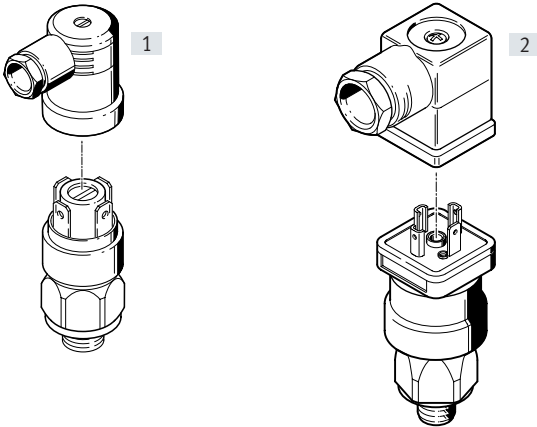

Mounting attachments and accessories		→ Page
[1]	Angled plug socket PEV-1/4-A-WD	22
[2]	Angled plug socket PEV-1/4-WD-LED-...	20

Type codes – Pressure switch PEV-SW27, screw-in

001	Series
PEV	Pressure switch

002	Pneumatic connection
1/4	G1/4

003	Generation
A	Series A

004	Width across flats
SW27	27 mm

005	Electrical connection
	For angled plug socket PEV-1/4-A-WD
B-OD	For angled plug socket PEV-1/4-WD-LED-...

Datasheet – Pressure switch PEV-SW27, screw-in

Function

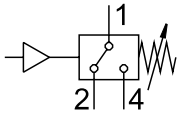

General technical data

Type	PEV-1/4-A-SW27	PEV-1/4-A-SW27-B-OD
General		
Pneumatic connection	G1/4	
Type of mounting	Screw-in	
Mounting position	Any	
Input signal/measuring element		
Measured variable	Relative pressure	
Measurement method	Pneumatic/electric pressure transducer	
Pressure measuring range [bar]	1 ... 10	–

Electrical data

Type	PEV-1/4-A-SW27	PEV-1/4-A-SW27-B-OD
Switching output		
Switching element function	Changeover switch	
Max. switching frequency [Hz]	3	
Max. switching output voltage	[V AC]	250
	[V DC]	250
Max. output current [mA]	4000	
Operating voltage range [V DC]	12 ... 250	–
Electromechanics		
Electrical connection	Plug, 4-pin	

Pin assignment

PEV-1/4-A-SW27	Pin	Description
	1	Switchable voltage
	2	N/C
	4	N/O

PEV-1/4-A-SW27-B-OD	Pin	Description
	1	Switchable voltage
	2	N/C
	4	N/O

Display/operation

Switching output		
Threshold-value setting range [bar]	1 ... 10	

Materials

Type	PEV-1/4-A-SW27	PEV-1/4-A-SW27-B-OD
Housing material	Galvanised steel	PA66-GF30 Galvanised steel
Diaphragm material	NBR	
LABS (PWIS) conformity	VDMA24364-B1/B2-L	

Datasheet – Pressure switch PEV-SW27, screw-in

Operating and environmental conditions		
Type	PEV-1/4-A-SW27	PEV-1/4-A-SW27-B-OD
Operating pressure [bar]	1 ... 10	
Operating medium	Compressed air to ISO 8573-1:2010 [7:-;-]	
Note on the operating/pilot medium	Lubricated operation possible (in which case lubrication will always be required)	–
Temperature of medium [°C]	–20 ... +80	
Ambient temperature [°C]	–20 ... +100	–30 ... +100
CE marking (see declaration of conformity) ¹⁾	To EU Low Voltage Directive	
UKCA marking (see declaration of conformity) ¹⁾	–	To UK regulations for electrical equipment
Degree of protection	IP65	

1) More information: www.festo.com/catalogue/pev → Support/Downloads.

Dimensions

PEV-1/4-A-SW27

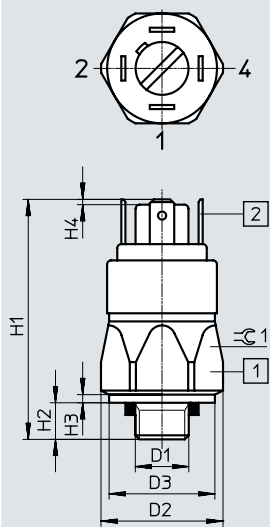

- [1] Max. tightening torque 50 Nm
- [2] Integrated plug to DIN 46 244

Download CAD data → www.festo.com

PEV-1/4-A-SW27-B-OD

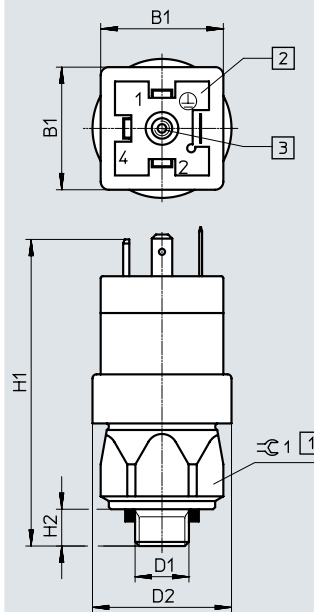

- [1] Max. tightening torque 50 Nm
- [2] Integrated plug to EN 175201-803
- [3] Switching-point adjustment

Type	B1	D1	D2	D3	H1	H2	H3	H4	≙C1
PEV-1/4-A-SW27	–	G1/4	30	26	58	8	2	1.3	27
PEV-1/4-A-SW27-B-OD	30		34	–	74				

Ordering data

	Pneumatic connection	Electrical connection	Product weight [g]	Part no.	Type
	G1/4	For angled plug socket PEV-1/4-A-WD	138	159259	PEV-1/4-A-SW27
	G1/4	For angled plug socket PEV-1/4-WD-LED-...	900	175252	PEV-1/4-A-SW27-B-OD

Accessories

Angled plug socket

PEV-1/4-WD-LED-...

For pressure switches PEV-1/4-B-(OD),

PEV-1/4-SC-OD and

PEV-1/4-A-SW27-B-OD

With integrated LEDs for
switching status indication



General technical data

Type of mounting	Screw-clamped
Cable outlet	Angled
Switching status indication	Yellow LED Green LED

Electronics

Type	PEV-1/4-WD-LED-24	PEV-1/4-WD-LED-230
Operating voltage range	[V AC]	–
	[V DC]	15 ... 30
		150 ... 230
		140 ... 180

Electromechanics

Type	PEV-1/4-WD-LED-24	PEV-1/4-WD-LED-230	
Electrical connection 1	Function	Field device side	
	Design	Square	
	Connection type	Socket	
	Connection technology	Plug pattern type A based on EN 175301-803	
	Number of pins/wires	4	
	Assigned pins/wires	4	
	Type of mounting	Central screw M3	
	Tightening torque	0.5 Nm	
Electrical connection 2	Function	Controller side	
	Connection technology	Screw terminal	
	Number of pins/wires	5	
	Assigned pins/wires	5	
Cable fitting	Pg11		
Current rating at 40°C	[A]	8	–
Permissible cable diameter	[mm]	4.5 ... 11	
Connection cross section	[mm ²]	0.25 ... 1.5	

Operating and environmental conditions

Type	PEV-1/4-WD-LED-24	PEV-1/4-WD-LED-230	
Ambient temperature	[°C]	–40 ... +80	
CE marking (see declaration of conformity)	To EU RoHS Directive	–	
		To EU Low Voltage Directive	
UKCA marking (see declaration of conformity)	To UK RoHS regulations	–	
		To UK regulations for electrical equipment	
Conforms to	EN 175301-803		
Degree of protection	IP65		
Note on degree of protection	In mounted state		

Accessories

Materials

Housing material	Reinforced PA6
Housing colour	Transparent
Information on pin contact materials	Brass Nickel-plated Tin-plated
Note on materials	RoHS-compliant
LABS (PWIS) conformity	VDMA24364-B2-L

Dimensions

Download CAD data → www.festo.com

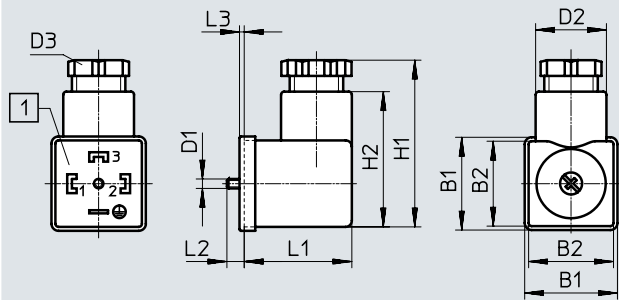

[1] Inserts can be rotated 90°

Dimensions and ordering data

Type	B1	B2	D1	D2 ∅	D3	H1	H2	L1	L2	L3	Weight [g]	Part no.	Type
PEV...-24	30	27.5	M3	22.5	Pg11	53	43	34.2	5.5	1.5	34	164274	PEV-1/4-WD-LED-24
PEV...-230											34	164275	PEV-1/4-WD-LED-230

Accessories

Angled plug socket PEV-1/4-A-WD

For pressure switch

PEV-1/4-A-SW27



General technical data

Type of mounting	With through-hole
------------------	-------------------

Electromechanics

Electrical connection	Angled socket, 4-pin
-----------------------	----------------------

Operating and environmental conditions

Ambient temperature	[°C]	-40 ... +90
Degree of protection		IP65

Materials

Note on materials	RoHS-compliant
LABS (PWIS) conformity	VDMA24364-B1/B2-L

Dimensions

Download CAD data → www.festo.com

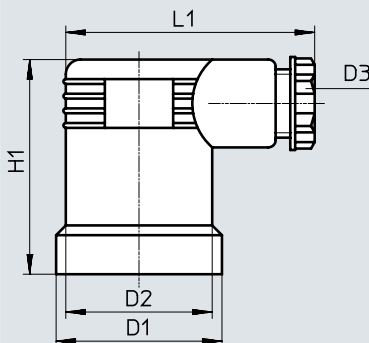

Dimensions and ordering data

D1	D2	D3	H1	L1	Weight [g]	Part no.	Type
∅	∅						
34	30	Pg9	44	51	55	161209	PEV-1/4-A-WD

Accessories

Mounting plate APL

For pressure switch PEV and vacuum switch VPEV

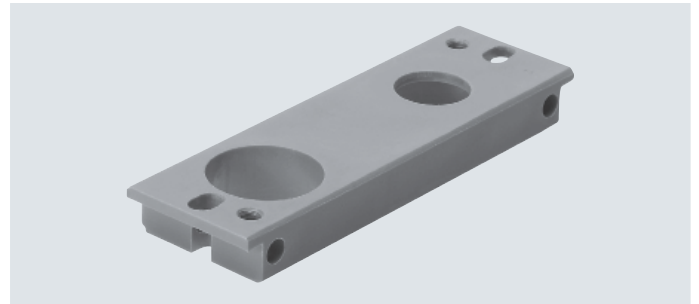

Dimensions

Download CAD data → www.festo.com

For pressure switch PEV

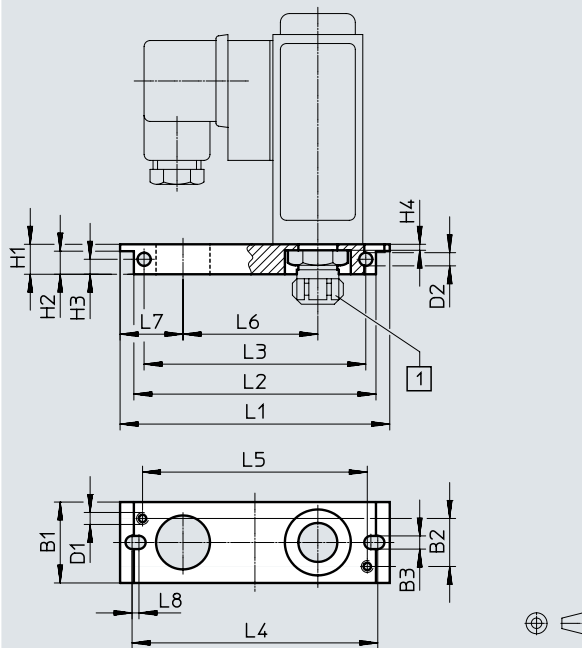

[1] CK-1/4-...

For vacuum switch VPEV

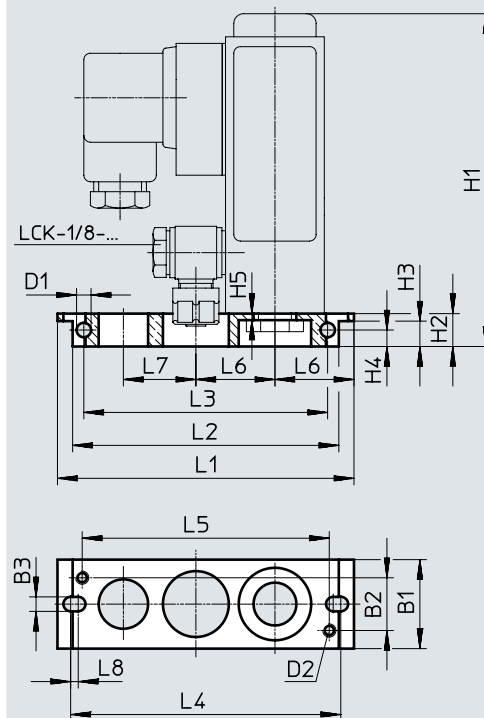

Dimensions and ordering data

	B1	B2	B3	D1	D2	H1	H2	H3	H4	H5	L1
For PEV	27	16	4.4	M4	4.4	10	7.7	5	2	–	88.5
For VPEV				4.4	M4	101	10	7.7	5	2	

	L2	L3	L4	L5	L6	L7	L8	Weight [g]	Part no.	Type
For PEV	80.8	74	82	75	45	21	2.3	18	9349	APL-2N-PEV
For VPEV			81		24	22		18	150218	APL-2N-VPEV

Accessories

Mounting frame NRRQ
Mounting bracket NRW

Scope of delivery:
 2 x Connecting piece NRV-2N
 2 x Profile rail NRQ-8-480
 4 x Mounting bracket NRW-1 2/3
 4 x Bolt NRB-1 2/60
 4 x Socket head screw
 DIN 84-M6X18-4.8
 4 x Socket head screw
 DIN 84-M6X12-4.8
 4 x Mounting bracket NRW-9/1.5-B
 4 x Socket head screw
 DIN 84-M4X10-4.8



Dimensions – Mounting frame NRRQ

Download CAD data → www.festo.com

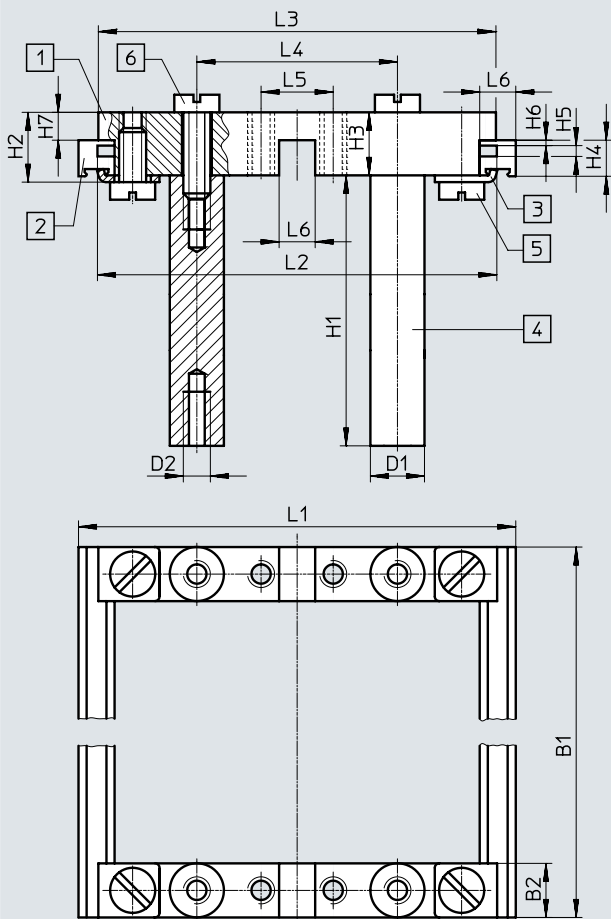

- [1] Connecting component NRV-2N
- [2] Profile strip NRQ-8-480
- [3] Mounting bracket NRW-1 2/3
- [4] Bolt NRB-1 2/60
- [5] Socket head screw
DIN 84-M6X12-4.8
- [6] Socket head screw
DIN 84-M6X18-4.8

B1	B2	D1 ∅	D2	H1	H2	H3	H4	H5	H6	H7	L1	L2	L3	L4	L5	L6
480	12	12	M6	60	15.5	14	8	2.4	1.2	6.2	97	88.6	88.2	44.5	16	8

Dimensions and ordering data

	Part no.	Type
Mounting frame complete for 16 elements	9365	NRRQ-2N
Mounting bracket for mounting sub-bases on the frame	11571	NRW-9/1.5-B

Accessories

Ordering data – Plug socket MSSD			Datasheets → Internet: mssd	
	Electrical connection	Cable fitting	Part no.	Type
	Angled socket, 3-pin, type A	Pg9	171157	MSSD-C-4P

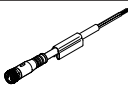
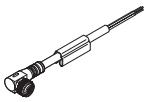
Ordering data – Connecting cable NEBU-M8			Datasheets → Internet: nebu		
	Electrical connection	Number of cores	Cable length [m]	Part no.	Type
	M8x1, straight socket	4	2.5	541342	NEBU-M8G4-K-2.5-LE4
			5	541343	NEBU-M8G4-K-5-LE4
	M8x1, angled socket	4	2.5	541344	NEBU-M8W4-K-2.5-LE4
			5	541345	NEBU-M8W4-K-5-LE4

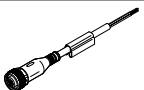
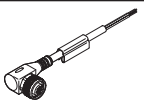
Ordering data – Connecting cable NEBU-M12			Datasheets → Internet: nebu		
	Electrical connection	Number of cores	Cable length [m]	Part no.	Type
	M12x1, straight socket	4	2.5	550326	NEBU-M12G5-K-2.5-LE4
			5	541328	NEBU-M12G5-K-5-LE4
	M12x1, angled socket	4	2.5	550325	NEBU-M12W5-K-2.5-LE4
			5	541329	NEBU-M12W5-K-5-LE4

Ordering data – DIN mounting rail NRC			Datasheets → Internet: nrc	
	Description	Length	Part no.	Type
	G-rail to EN 50035	2 m	6756	NRC-32-2000

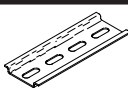
Ordering data – DIN mounting rail NRH			Datasheets → Internet: nrh	
	Description	Length	Part no.	Type
	H-rail to EN 60715	2 m	35430	NRH-35-2000

Ordering data – Mounting latch PENV			Datasheets → Internet: penv	
	Description	Part no.	Type	
	For mounting on DIN mounting rail	164597	PENV-BGH	

Festo - Your Partner in Automation



1 Festo Inc.
5300 Explorer Drive
Mississauga, ON L4W 5G4
Canada

Festo Customer Interaction Center
Tel: 1 877 463 3786
Fax: 1 877 393 3786
Email: customer.service.ca@festo.com

2 Festo Pneumatic
Av. Ceylán 3,
Col. Tequesquináhuac
54020 Tlalneantla,
Estado de México

Multinational Contact Center
01 800 337 8669
ventas.mexico@festo.com

3 Festo Corporation
1377 Motor Parkway
Suite 310
Islandia, NY 11749

Festo Customer Interaction Center
1 800 993 3786
1 800 963 3786
customer.service.us@festo.com

4 Regional Service Center
7777 Columbia Road
Mason, OH 45040

Connect with us



www.festo.com/socialmedia



www.festo.com

Subject to change