

Radial grippers DHRC

FESTO



Key features

At a glance

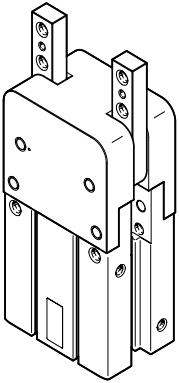

- Lateral gripper jaw support for high torque loads
- Gripper jaw centring options
- Maximum repetition accuracy
- Proximity switch for sensing the piston position at the end positions and position transmitter for sensing the piston position at any location
- Wide range of adaptation options on the drives
- Flexible application options: can be used as a double-acting and single-acting gripper

Position sensing

[A] Via proximity switch

The position sensing function uses proximity switches to sense any required positions.

Gripper function

[] Double-acting

Open or close when pressurised with compressed air

[S] Single-acting, open

Open in unpressurised state. Closed when pressurised with compressed air

Gripping force backup

[NO] Opening

Opened by spring force when unpressurised

-  - **Note**

Engineering software
Gripper selection
→ www.festo.com

Key features

Supply ports

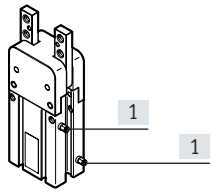

[1] Supply ports

Mounting options

On the side

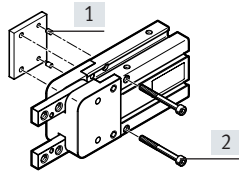
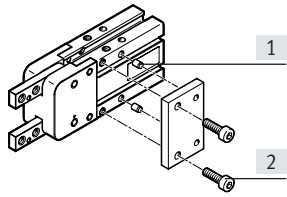

Vertical

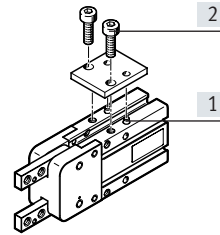

[1] Centring sleeves
[2] Retaining screws

From underneath

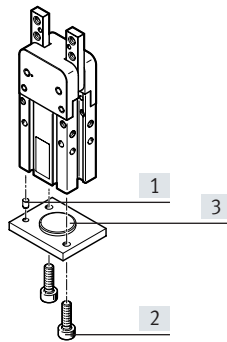
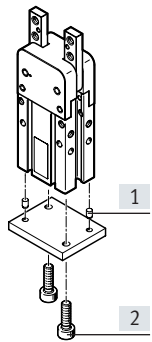

[1] Centring sleeves
[2] Retaining screws
[3] Base

Mounting external gripper fingers

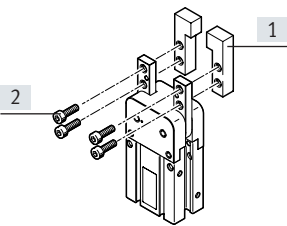

[1] External gripper fingers
[2] Retaining screws

Note
This gripper is not suitable for the following or similar applications:

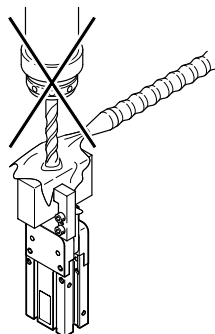

- Machining
- Aggressive media

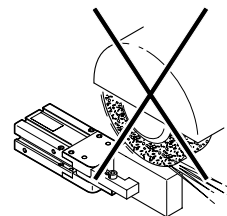

- Grinding dust

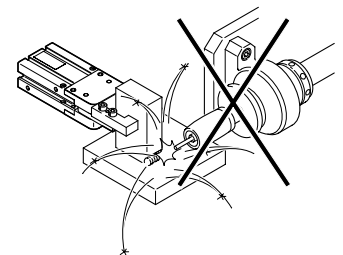

- Welding spatter

Peripherals overview

Peripherals overview

Size 6

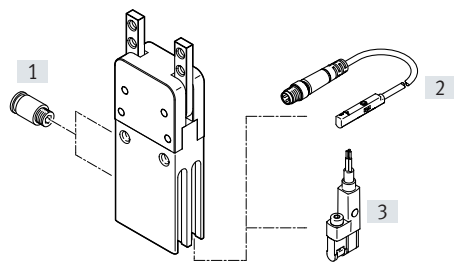

Size 10

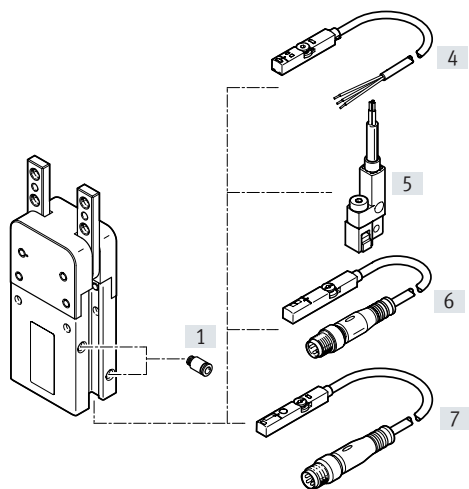

Size 16 ... 32

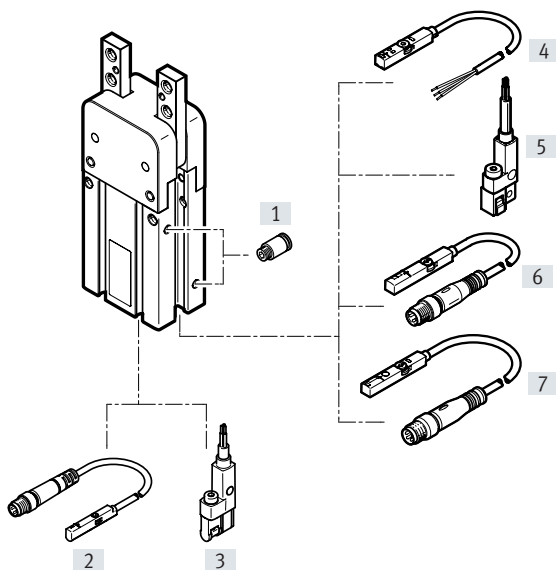

Accessories

Type/order code	For size	Description	→ Page/Internet
[1] Push-in fitting QS	6 ... 32	For connecting tubing with standard O.D.	qs
[2] Proximity switch SMT-10M	6, 16 ... 32	For sensing the piston position at the end positions	21
[3] Proximity switch SMT-10G	6, 16 ... 32	For sensing the piston position at the end positions	21
[4] Proximity switch SMT-8M	10 ... 32	For sensing the piston position at the end positions	21
[5] Proximity switch SMT-8G	10 ... 32	For sensing the piston position at the end positions	21
[6] Position transmitter SMAT-8M	10 ... 32	For sensing the piston position at any location	22
[7] Position transmitter SDAS-MHS	10 ... 32	For sensing the piston position at any location	22

Type codes

001	Series
DHRC	Radial gripper

002	Size [mm]
6	6
10	10
16	16
20	20
25	25
32	32

003	Position sensing
A	For proximity sensor

004	Gripper function
	Double-acting
S	Single-acting, open

005	Gripping force backup
	None
NO	Opening

Datasheet

Function

Double-acting
DHRC...-A

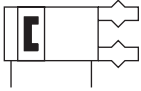

-  Size
6 ... 32 mm

-  Opening angle
180°

 www.festo.com

Function – variants

Single-acting
Opening: DHRC...-S-NO



General technical data		6	10	16	20	25	32
Design	Connection direction on the side, force-guided motion sequence						
Mode of operation	Double-acting	Double-acting, single-acting, open					
Gripper function	Radial						
Number of gripper jaws	2						
Max. opening angle	180 deg						
Pneumatic connection	M3				M5		
Gripper repetition accuracy ¹⁾	≤0.1 mm						
Rotational symmetry	≤0.2 mm						
Max. interchangeability	≤0.2 mm						
Max. operating frequency of gripper	≤3 Hz			≤2 Hz			
Position sensing	Via proximity switch						
Type of mounting	Optional: direct mounting via through-hole, direct mounting via thread	Optional: direct mounting via through-hole, direct mounting via thread, with through-hole and dowel pin, with female thread and dowel pin					
Mounting position	Any						

1) Under constant exposure to operating conditions, end-position drift occurs in the direction of movement of the gripper jaws, at 100 consecutive strokes

Operating and environmental conditions		6	10	16	20	25	32
Operating medium	Compressed air to ISO 8573-1:2010 [7:4:4]						
Note on the operating/pilot medium	Lubricated operation possible (in which case lubricated operation will always be required)						
Ambient temperature ¹⁾	-10 ... 60 °C						
Corrosion resistance class CRC ²⁾	0 - no corrosion stress						

1) Note operating range of proximity switches

2) Corrosion resistance class CRC 0 to Festo standard FN 940070

No corrosion stress. Applies to small, visually unimportant standards-based parts such as threaded pins, circlips and clamping sleeves that are usually only available on the market in a phosphated or burnished version (and possibly oiled) as well as to ball bearings (for components < CRC 3) and plain bearings.

Datasheet

Operating pressure DHRC-...						
Size	6	10	16	20	25	32
Operating pressure	0.25 ... 0.8 MPa		0.1 ... 0.8 MPa			
Operating pressure	36.25 ... 116 psi		14.5 ... 116 psi			
Operating pressure	2.5 ... 8 bar		1 ... 8 bar			

Operating pressure DHRC-...-NO						
Size	10	16	20	25	32	
Operating pressure	0.2 ... 0.8 MPa		0.15 ... 0.8 MPa			
Operating pressure	29 ... 116 psi		21.75 ... 116 psi			
Operating pressure	2 ... 8 bar		1.5 ... 8 bar			

Weight DHRC-...						
Size	6	10	16	20	25	32
Product weight	24.5 g	54 g	111 g	218.4 g	438.5 g	716.5 g

Weight DHRC-...-NO						
Size	10	16	20	25	32	
Product weight	59.5 g	112.5 g	220 g	440 g	720.5 g	

Materials						
Size	6	10	16	20	25	32
Housing material	Anodised wrought aluminium alloy					
Gripper jaw material	High-alloy steel					
Cover cap material	Anodised wrought aluminium alloy					
Note on materials	Free of copper and PTFE, RoHS-compliant					

Datasheet

Opening and closing times

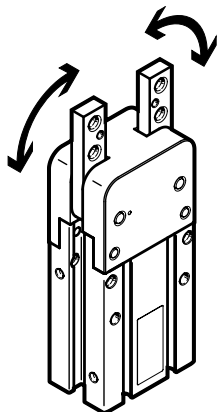

The indicated opening and closing times [ms] were measured at room temperature at an operating pressure of 6 bar with the gripper horizontally mounted and without additional gripper fingers (mean values shown).
The grippers must be throttled when handling heavier loads. Opening and closing times must then be adjusted accordingly.

Opening and closing times DHRC...

Size	6	10	16	20	25	32
Min. opening time at 6 bar	10 ms	28 ms	37 ms	44 ms	90 ms	117 ms
Min. closing time at 6 bar	19 ms	43 ms	53 ms	57 ms	117 ms	129 ms

Opening and closing times DHRC...-NO

Size	10	16	20	25	32
Min. opening time at 6 bar	53 ms	42 ms	73 ms	147 ms	229 ms
Min. closing time at 6 bar	26 ms	21 ms	32 ms	45 ms	65 ms

Datasheet

Opening and closing times t to be set at 6 bar as a function of mass moment of inertia of the gripper fingers

DHRC-6

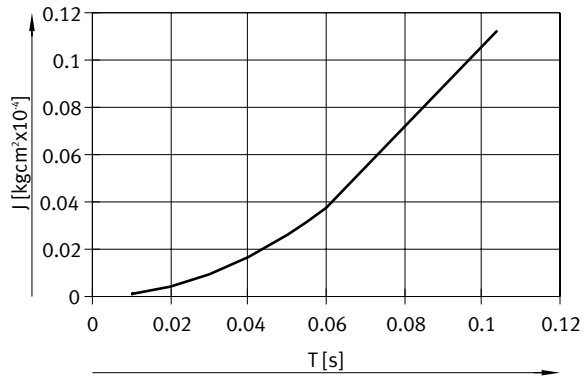

DHRC-10

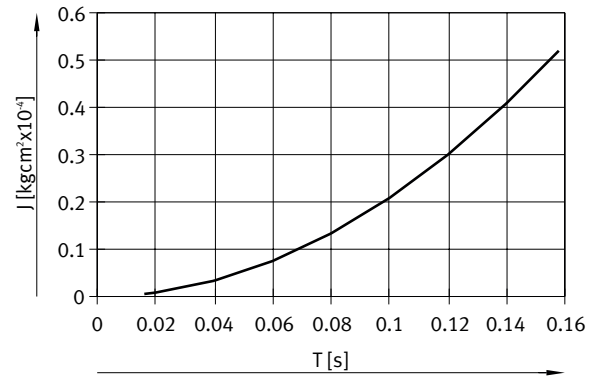

DHRC-16

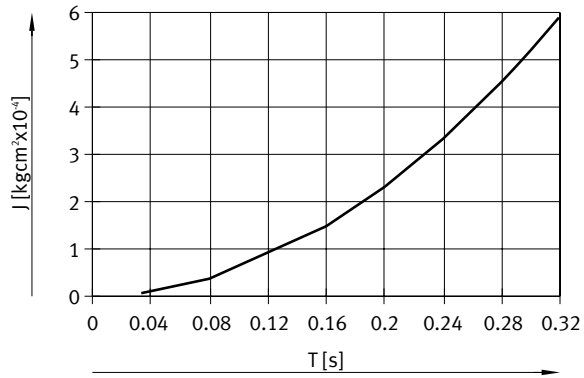

DHRC-20

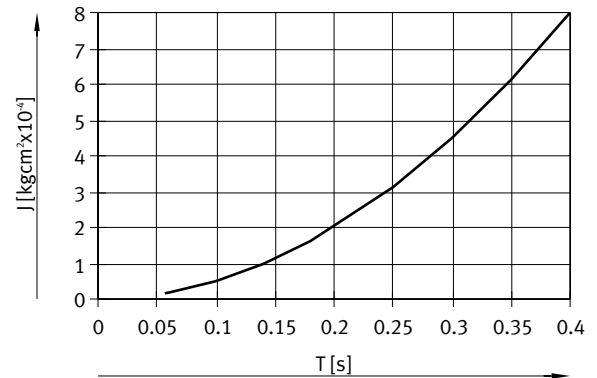

DHRC-25

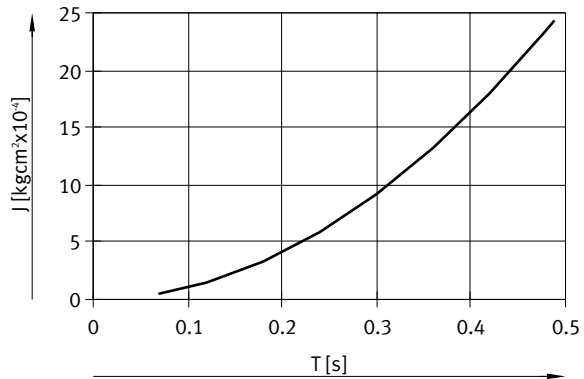

DHRC-32

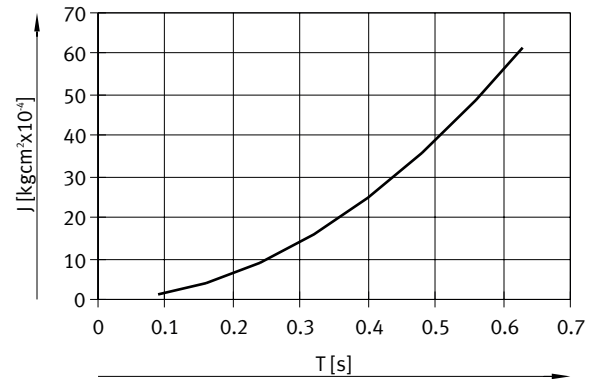

Datasheet

Total gripping torque

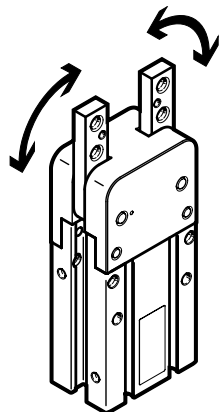

The gripping torque is not constant across the opening angle → page 15.

Total gripping torque DHRC...

Size	6	10	16	20	25	32
Total gripping torque at 6 bar, opening	6.7 Ncm	25.3 Ncm	81.1 Ncm	166.2 Ncm	343.6 Ncm	725.6 Ncm
Total gripping torque at 6 bar, closing	4.8 Ncm	20.4 Ncm	66.8 Ncm	134.3 Ncm	277.5 Ncm	600.1 Ncm

Total gripping torque DHRC...-NO

Size	10	16	20	25	32
Total gripping torque at 6 bar, closing	15.8 Ncm	50.3 Ncm	112 Ncm	239.5 Ncm	539.1 Ncm

Static characteristic load values at the gripper jaws

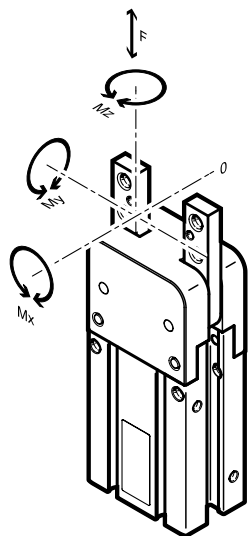

The indicated permissible forces and torques apply to a single gripper jaw. They include the lever arm, additional applied loads created by the workpiece or external gripper fingers and acceleration forces occurring during movement. The zero coordinate line (gripper jaw guide) must be taken into consideration when calculating torques.

Static characteristic load values at the gripper jaws

Size	6	10	16	20	25	32
Max. force on gripper jaw F_z , static	12 N	35 N	60 N	100 N	140 N	210 N
Maximum torque on gripper jaw M_x , static	0.3 Nm	0.5 Nm	2 Nm	4 Nm	7 Nm	12 Nm
Maximum torque on gripper jaw M_y , static	0.3 Nm	0.5 Nm	1 Nm	2 Nm	4 Nm	8 Nm
Maximum torque on gripper jaw M_z , static	0.3 Nm	0.5 Nm	2 Nm	4 Nm	7 Nm	12 Nm

Datasheet

Mass moments of inertia

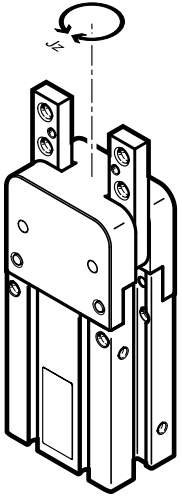

Mass moment of inertia of the radial gripper in relation to the central axis, without external gripper fingers, with no load.

Mass moments of inertia DHRC-...						
Size	6	10	16	20	25	32
Mass moment of inertia	0.01 kgcm ²	0.04 kgcm ²	0.132 kgcm ²	0.292 kgcm ²	1.311 kgcm ²	3.105 kgcm ²

Mass moments of inertia DHRC-...-NO					
Size	10	16	20	25	32
Mass moment of inertia	0.044 kgcm ²	0.134 kgcm ²	0.294 kgcm ²	1.316 kgcm ²	3.122 kgcm ²

Datasheet

Gripping force F_{gr} per gripper jaw as a function of the operating pressure and lever arm x

The gripping forces as a function of the operating pressure and lever arm can be determined from the following graphs.

The gripping torque is not constant across the opening angle
 → page 15.

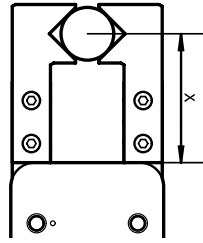

- 2 bar
- · - · 4 bar
- - - 6 bar
- 8 bar

Note
 Engineering software
 Gripper selection
 → www.festo.com

External gripping (closing)

Double-acting

DHRC-6-A

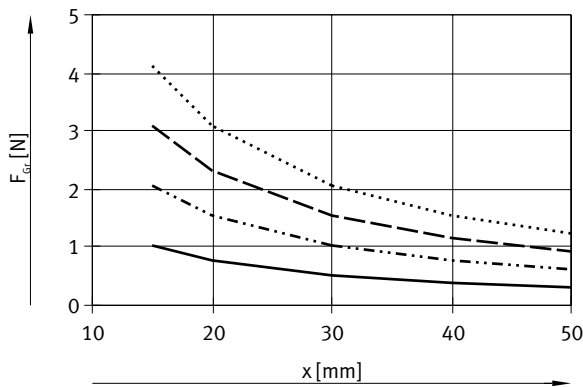

DHRC-10-A

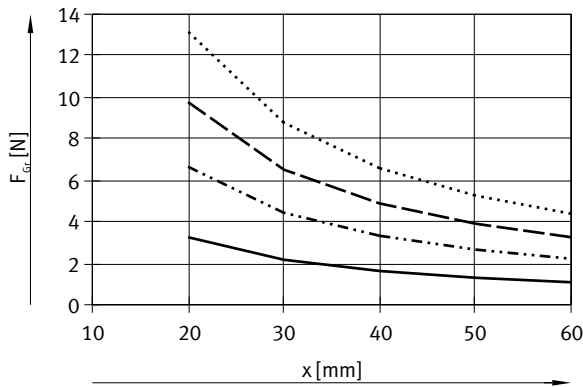

DHRC-16-A

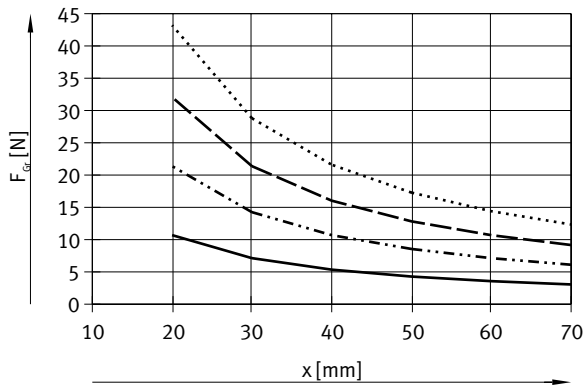

Single-acting

DHRC-10-AS-NO

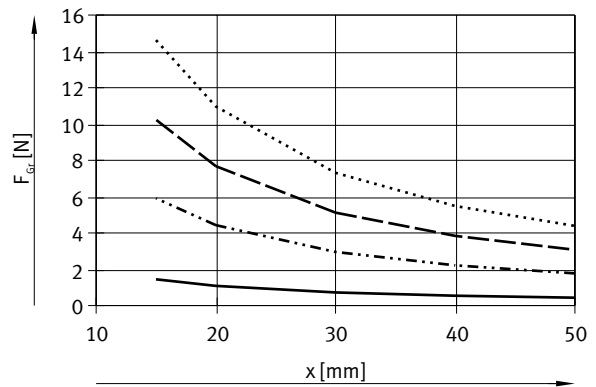

DHRC-16-AS-NO

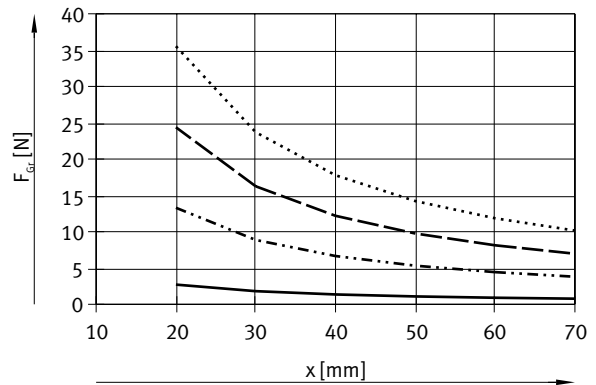

Datasheet

Gripping force F_{Gr} per gripper jaw as a function of the operating pressure and lever arm x

The gripping forces as a function of the operating pressure and lever arm can be determined from the following graphs.

The gripping torque is not constant across the opening angle
 → page 15.

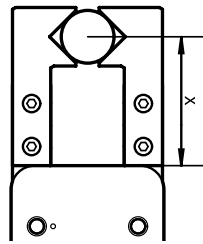

- 2 bar
- · - · 4 bar
- - - 6 bar
- · · · · 8 bar

Note
 Engineering software
 Gripper selection
 → www.festo.com

External gripping (closing)

Double-acting

DHRC-20-A

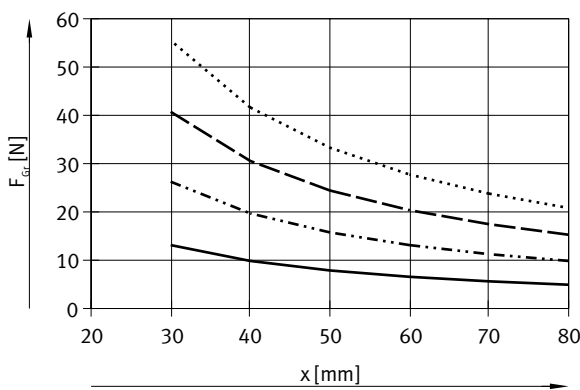

Single-acting

DHRC-20-AS-NO

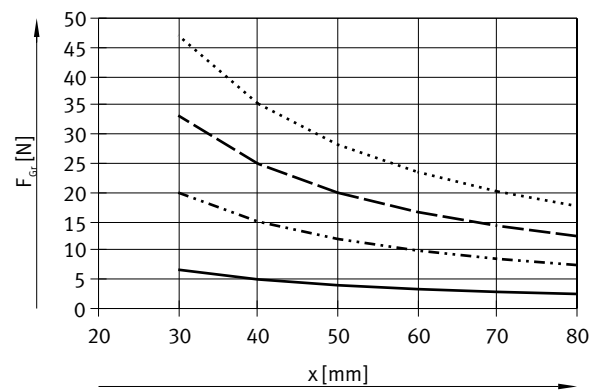

DHRC-25-A

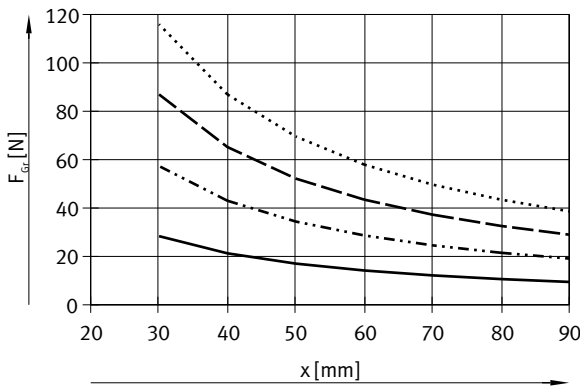

DHRC-25-AS-NO

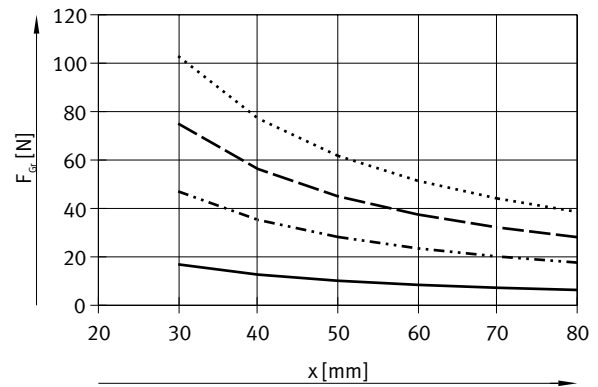

DHRC-32-A

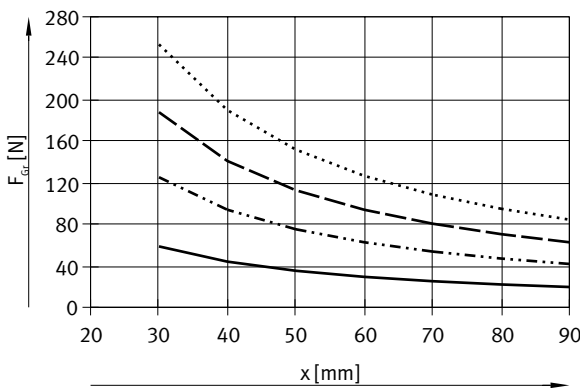

DHRC-32-AS-NO

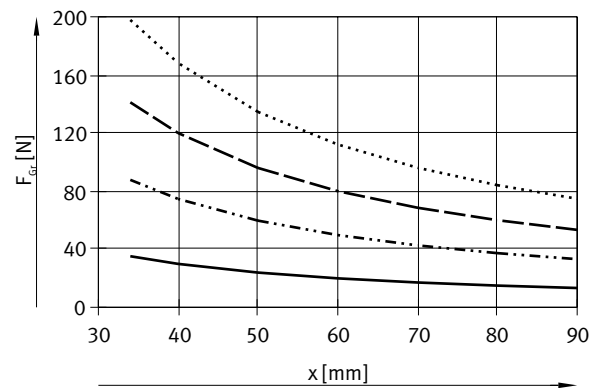

Datasheet

Gripping force F_{Gr} per gripper jaw as a function of the operating pressure and lever arm x

The gripping forces as a function of the operating pressure and lever arm can be determined from the following graphs.

The gripping torque is not constant across the opening angle
 → page 15.

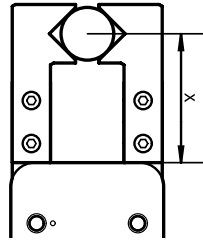

- 2 bar
- · - · - 4 bar
- - - 6 bar
- · · · · 8 bar

Note
 Engineering software
 Gripper selection
 → www.festo.com

Internal gripping (opening)

Double-acting

DHRC-6-A

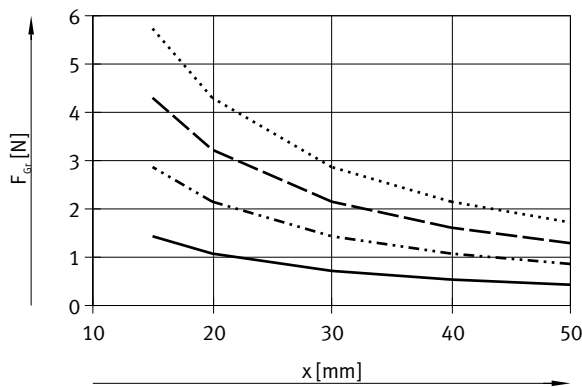

DHRC-10-A

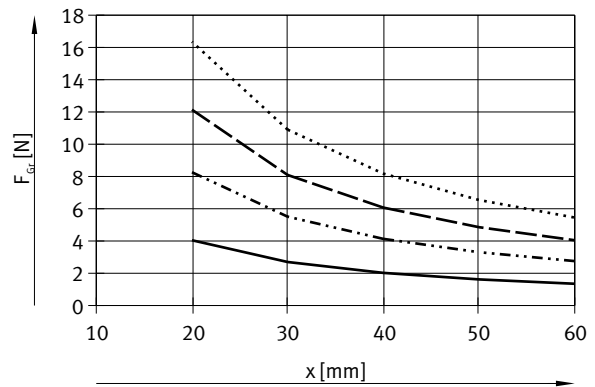

DHRC-16-A

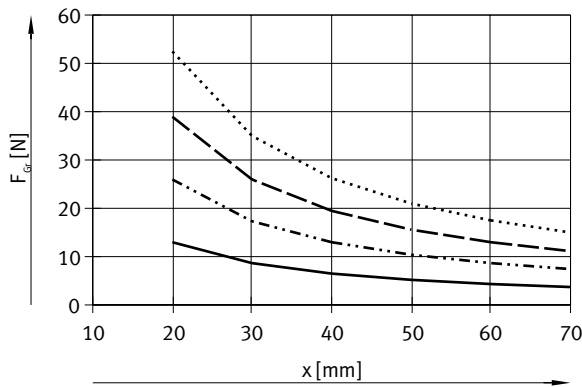

DHRC-20-A

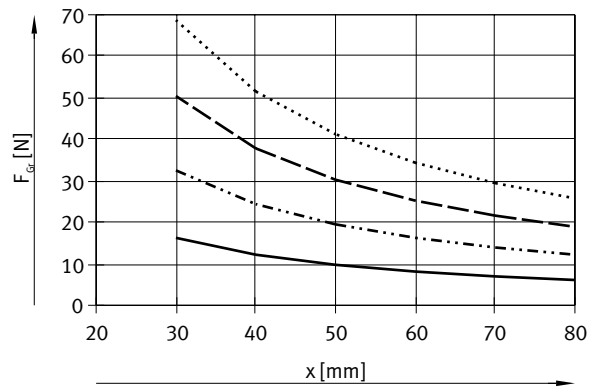

DHRC-25-A

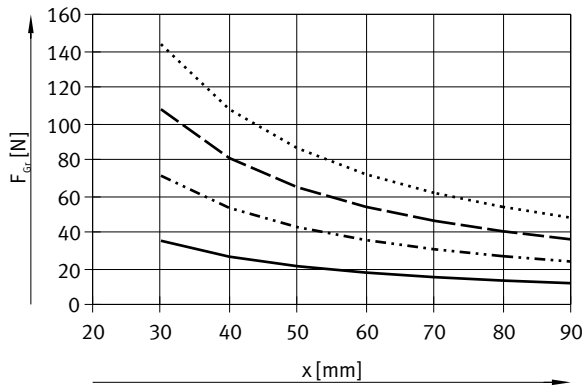

DHRC-32-A

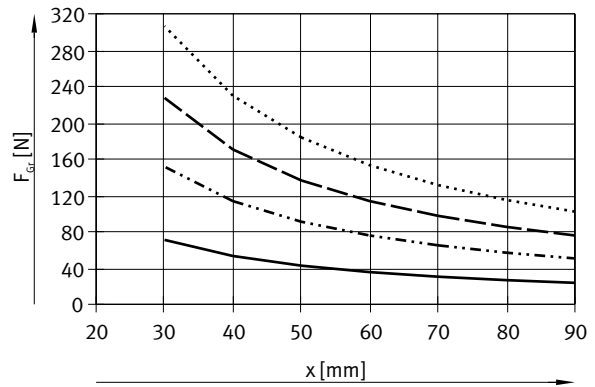

Datasheet

Gripping force F_{Gr} per gripper jaw at 6 bar as a function of lever arm x and eccentricity a and b

The following formula must be used to calculate the lever arm x with eccentric gripping:

$$x = \sqrt{a^2 + b^2}$$

The gripping force F_{Gr} can then be read from the graphs (→ page 12/13/14) using the calculated value x .

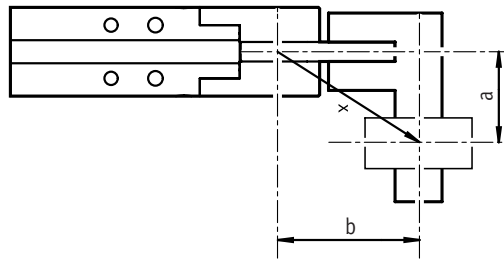

Calculation example

Assuming:

Distance $a = 20$ mm

Distance $b = 25$ mm

To be determined:

The gripping force at 6 bar, with a DHRC-16-A, used as an external gripper

Procedure:

Calculating the lever arm x

$$x = \sqrt{20^2 + 25^2}$$

$$x = 32 \text{ mm}$$

The graph

(→ page 12) gives a value for the gripping force of $F_{Gr} = 20$ N.

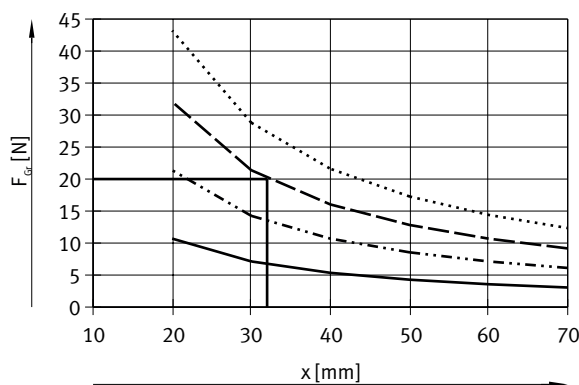
Torque curve M as a function of opening angle α

The drive principle of the gripper jaws means that the torque is not constant across the opening angle. The percentage of torque available in each case can be determined from the graph. Opening angle of 0° means: parallel gripper jaw position

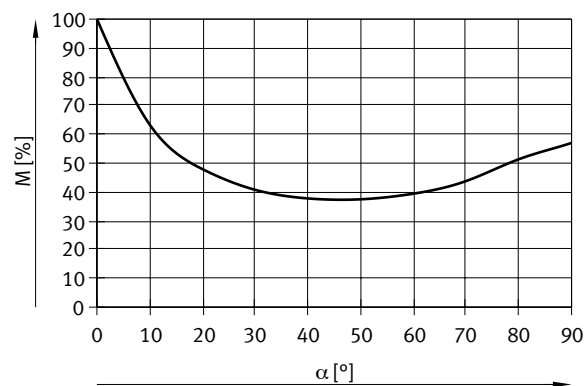

Datasheet

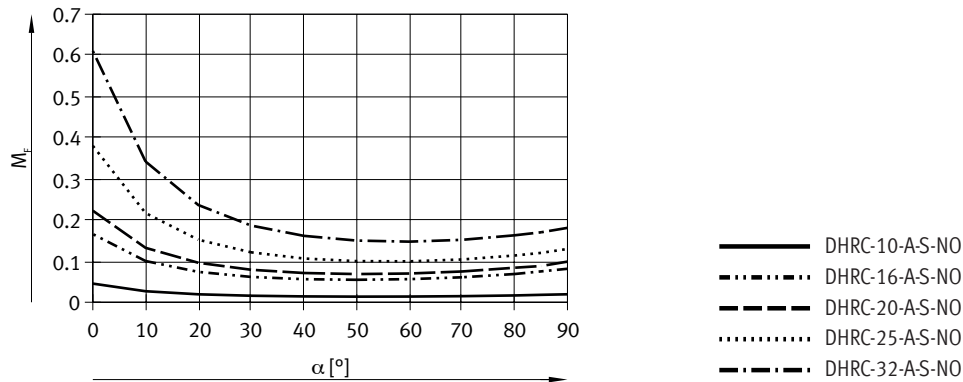
Spring torque M_F as a function of opening angle α Calculation of the actual gripping torques $M_{Gr_{ges}}$ for DHRC-...-S-NO as a function of the application

The radial gripper with integrated spring, DHRC-...-S-NO (opening), can be used as follows:

- Single-acting gripper

To calculate the available gripping torque $M_{Gr_{ges}}$ (per gripper jaw), the data from the graphs for gripping force F_{Gr} (→ page 12/13/14),

$$M_{Gr} = F_{Gr} \cdot x \cdot M \text{ [%]}$$

torque curve M (→ page 15) and

spring torque M_F (→ page 16) must be combined accordingly.

M_{Gr} Gripping torque

F_{Gr} Gripping force

x Lever arm

M Torque curve

Datasheet

Dimensions

Download CAD data → www.festo.com

DHRC-6

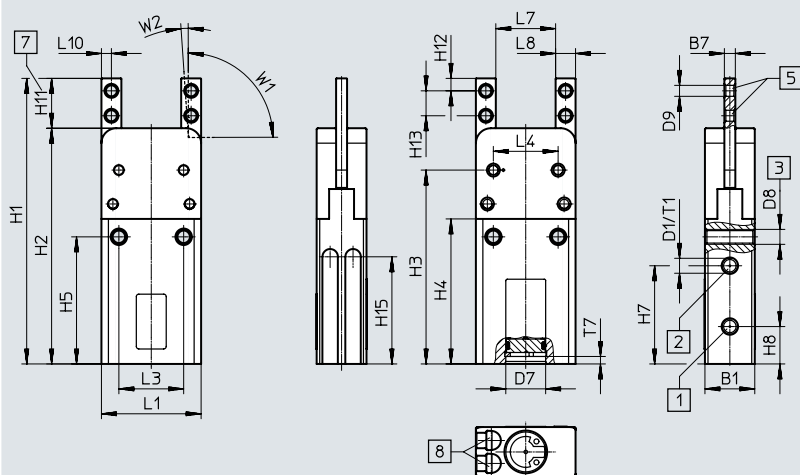

- [1] Pneumatic connection, opening
- [2] Pneumatic connection, closing
- [3] Threaded hole for mounting the gripper
- [5] Threaded hole for mounting the gripper fingers
- [7] Area for mounting the gripper fingers
- [8] C-slot for proximity switch

Size	B1	B7	D1	D7	D8	D9	H1	H2	H3	H4	H5	H7	H8	H11
[mm]	+0.3	-0.01 -0.05		∅ H8										-0.2
DHRC-6-A	10	2.2	M3	8	M3	2.2 ^{+0.1}	57.3	47.3	38.9	29.1	25.5	19.7	7.5	10

Size	H12	H13	H15	L1	L3	L4	L7	L8	L10	T1	T7	W1	W2
[mm]	-0.2			+0.3			-0.4	-0.4	+0.025 -0.225			±2°	+3°
DHRC-6-A	2.5	5	21.5	20	13	13	12	4	2	4.5	1.5	90°	2°

Datasheet

Dimensions

Download CAD data → www.festo.com

DHRC-10 ... 32

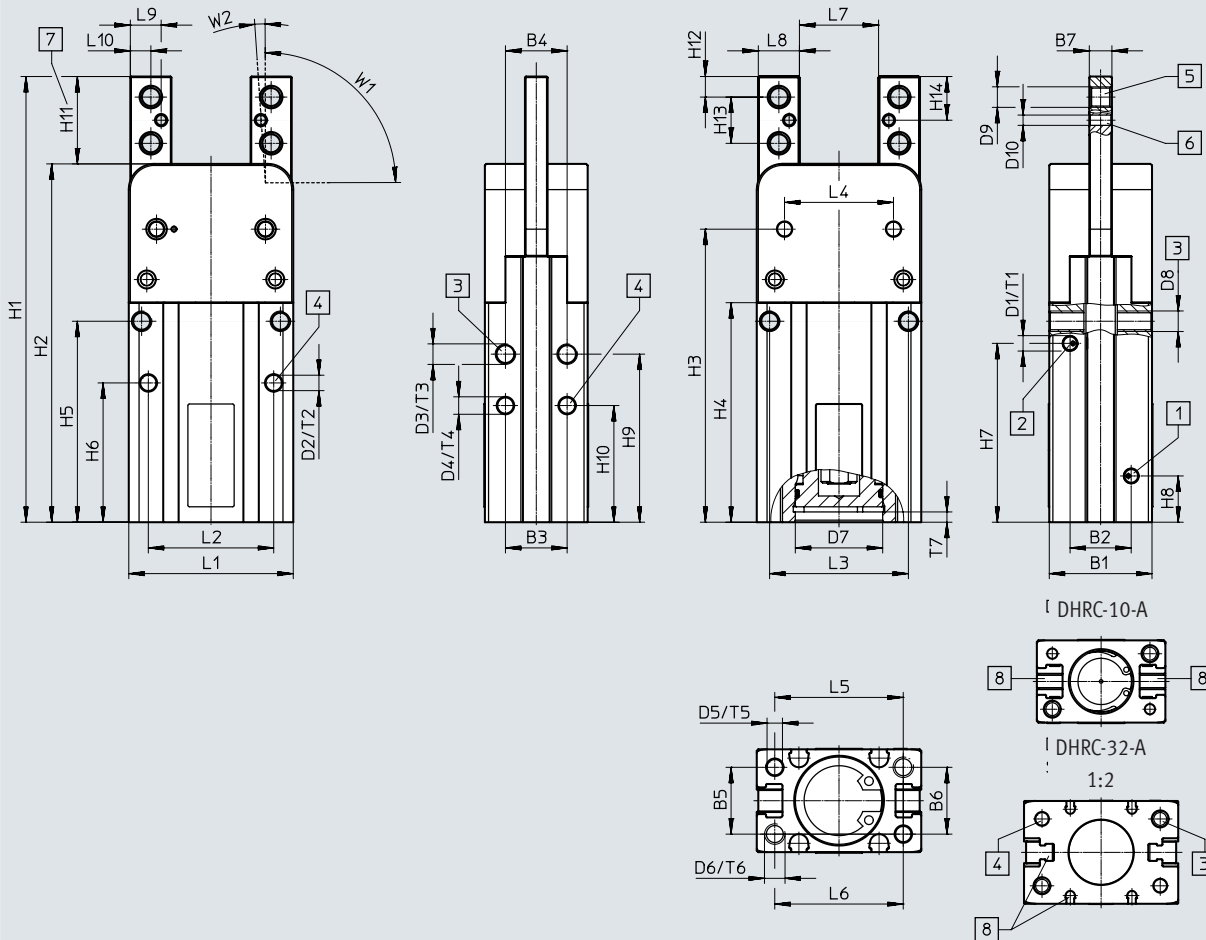

- [1] Pneumatic connection, opening
- [2] Pneumatic connection, closing
- [3] Threaded hole for mounting the gripper
- [4] Centring hole
- [5] Threaded hole for mounting the gripper fingers
- [7] Area for mounting the gripper fingers
- [8] DHRC-10: T-slot for proximity switch
DHRC-16 ... 32: C-slot and T-slot for proximity switch

Datasheet

Size	B1	B2	B3	B4	B5	B6	B7	D1	D2	D3	D4	D5	D6	D7	D8	D9	D10
[mm]	+0.3		±0.02			±0.02	-0.01 -0.05		∅ H9		∅ H9	∅ H9		∅ H8			∅ +0.02
DHRC-10-A	16	10.8	10.8	10.8	10.8	10.8	3	M3	2	M3	2	2	M3	12	M3	3.2 ^{+0.1}	2
DHRC-10-A-S-NO																	
DHRC-16-A	20	11.9	12	12	13	13	4.4	M3	3	M4	3	3	M4	17	M4	M4	3
DHRC-16-A-S-NO																	
DHRC-20-A	26	15.6	16	14	16.6	17	5.6	M5	4	M5	4	4	M5	21	M5	M4	3
DHRC-20-A-S-NO																	
DHRC-25-A	33	20.4	21	21	20	20	6.6	M5	4	M6	4	4	M6	26	M6	M5	3
DHRC-25-A-S-NO																	
DHRC-32-A	40	24	26	26	26	26	8.6	M5	5	M6	5	5	M6	25	M6	M6	3
DHRC-32-A-S-NO																	

Size	H1	H2	H3	H4	H5	H6	H7	H8	H9	H10	H11	H12	H13	H14	L1	L2	L3
[mm]						+0.1				+0.1	-0.2	-0.2		-0.2	+0.3	±0.02	
DHRC-10-A	69.2	53.6	43.8	-	27.5	17.5	21.5	7	22	14.4	15.6	3.5	8.6	7.8	25	18	18.6
DHRC-10-A-S-NO	75	59.4	49.6		33.3	23.3	27.3		27.8	20.2							
DHRC-16-A	86.7	69.7	57	42.7	39.1	27.1	34.8	9	32.7	22.7	17	4	9	8.5	32	24.4	27
DHRC-16-A-S-NO																	
DHRC-20-A	101.2	82.2	66.9	48.7	44.6	30.6	38.6	10.2	37.6	25.6	19	5	9	9.5	40	28.4	31.6
DHRC-20-A-S-NO																	
DHRC-25-A	122.6	99.6	79.9	58.1	53.4	38.4	46.4	10.5	45.4	33.4	23	5.5	12	11.5	50	37.2	37.4
DHRC-25-A-S-NO																	
DHRC-32-A	141.8	113.8	89.8	61.8	57.3	39.8	49.3	11	48.3	35.3	28	6	16	14	60	46	46
DHRC-32-A-S-NO																	

Size	L4	L5	L6	L7	L8	L9	L10	T1	T2	T3	T4	T5	T6	T7	W1	W2
[mm]		±0.02		-0.4	-0.4	+0.025 -0.225	-0.2								±2°	+3°
DHRC-10-A	15.8	19	19	13	6	3	3	4	3	4	3	3	4	1.5	90°	2°
DHRC-10-A-S-NO																
DHRC-16-A	21.2	25	25	15.4	8	6	4	4.5	4	4.5	3	3	6	2	90°	2°
DHRC-16-A-S-NO																
DHRC-20-A	26.8	31	30	22	9	6	4.5	6	4	8	4	4	10	2	90°	2°
DHRC-20-A-S-NO																
DHRC-25-A	33	38	38	29.4	10	5	5	7.5	4	10	4	4	12	2	90°	2°
DHRC-25-A-S-NO																
DHRC-32-A	39.8	46	46	34.4	12	6	6	7.5	5	10	5	5	13	2	90°	2°
DHRC-32-A-S-NO																

Ordering data

Ordering data				
Size [mm]	Double-acting		Single-acting Opening	
	Part no.	Type	Part no.	Type
6	8125285	DHRC-6-A	-	
10	8125472	DHRC-10-A	8133559	DHRC-10-A-S-NO
16	8128723	DHRC-16-A	8128721	DHRC-16-A-S-NO
20	8128697	DHRC-20-A	8128698	DHRC-20-A-S-NO
25	8128142	DHRC-25-A	8133557	DHRC-25-A-S-NO
32	8128107	DHRC-32-A	8133558	DHRC-32-A-S-NO



Accessories

Proximity switches for size 6, 16 ... 32

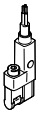

Ordering data – Proximity switch for C-slot, magneto-resistive							Datasheets → Internet: smt
	Type of mounting	Electrical connection, outlet direction of connection	Switching output	Cable length [m]	Part no.	Type	
N/O							
	Inserted in the slot from above	Cable, 3-core, lengthwise	PNP	2.5	551373	SMT-10M-PS-24V-E-2.5-L-OE	
		Plug M8x1, 3-pin, in-line		0.3	551375	SMT-10M-PS-24V-E-0.3-L-M8D	
		Cable, 3-core, crosswise	NPN	2.5	551374	SMT-10M-PS-24V-E-2.5-Q-OE	
		Plug M8x1, 3-pin, crosswise		0.3	551376	SMT-10M-PS-24V-E-0.3-Q-M8D	

Ordering data – Proximity switch for C-slot, magneto-resistive							Datasheets → Internet: smt
	Type of mounting	Electrical connection, outlet direction of connection	Switching output	Cable length [m]	Part no.	Type	
N/O							
	Inserted into the slot lengthwise	Cable, 3-core, crosswise	PNP	2.5	547862	SMT-10G-PS-24V-E-2.5Q-OE	
		Plug M8x1, 3-pin, crosswise		0.3	547863	SMT-10G-PS-24V-E-0.3Q-M8D	
		Cable, 3-core, crosswise	NPN	2.5	8065030	SMT-10G-NS-24V-E-2.5Q-OE	
		Plug M8x1, 3-pin, crosswise		0.3	8065029	SMT-10G-NS-24V-E-0.3Q-M8D	

Proximity switch for size 10 ... 32

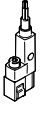
Ordering data – Proximity switch for T-slot, magneto-resistive							Datasheets → Internet: smt
	Type of mounting	Electrical connection outlet direction of connection	Switching output	Cable length [m]	Part no.	Type	
N/O							
	Inserted in the slot from above, short design	Cable, 3-core, lengthwise	PNP	2.5	574335	SMT-8M-A-PS-24V-E-2.5-OE	
		Plug M8x1, 3-pin, in-line		0.3	574334	SMT-8M-A-PS-24V-E-0.3-M8D	
		Plug M12x1, 3-pin, in-line		0.3	574337	SMT-8M-A-PS-24V-E-0.3-M12	
		Cable, 3-core, lengthwise	NPN	2.5	574338	SMT-8M-A-NS-24V-E-2.5-OE	
		Plug M8x1, 3-pin, in-line		0.3	574339	SMT-8M-A-NS-24V-E-0.3-M8D	
N/C							
	Inserted in the slot from above, short design	Cable, 3-core, lengthwise	PNP	7.5	574340	SMT-8M-A-PO-24V-E-7.5-OE	

Ordering data – Proximity switch for T-slot, magneto-resistive							Datasheets → Internet: smt
	Type of mounting	Electrical connection, outlet direction of connection	Switching output	Cable length [m]	Part no.	Type	
N/O							
	Inserted into the slot lengthwise	Cable, 3-core, crosswise	PNP	2.5	547859	SMT-8G-PS-24V-E-2.5Q-OE	
		Plug M8x1, 3-pin, crosswise		0.3	547860	SMT-8G-PS-24V-E-0.3Q-M8D	
		Cable, 3-core, crosswise	NPN	2.5	8065028	SMT-8G-NS-24V-E-2.5Q-OE	
		Plug M8x1, 3-pin, crosswise		0.3	8065027	SMT-8G-NS-24V-E-0.3Q-M8D	

Ordering data – Connecting cables						Datasheets → Internet: nebu
	Electrical connection, left	Electrical connection, right	Cable length [m]	Part no.	Type	
	Straight socket, M8x1, 3-pin	Cable, open end, 3-core	2.5	541333	NEBU-M8G3-K-2.5-LE3	
			5	541334	NEBU-M8G3-K-5-LE3	
	Straight socket, M12x1, 5-pin	Cable, open end, 3-core	2.5	541363	NEBU-M12G5-K-2.5-LE3	
			5	541364	NEBU-M12G5-K-5-LE3	
	Angled socket, M8x1, 3-pin	Cable, open end, 3-core	2.5	541338	NEBU-M8W3-K-2.5-LE3	
			5	541341	NEBU-M8W3-K-5-LE3	
	Angled socket, M12x1, 5-pin	Cable, open end, 3-core	2.5	541367	NEBU-M12W5-K-2.5-LE3	
			5	541370	NEBU-M12W5-K-5-LE3	

Accessories

Position transmitter for size 10 ... 32

The position transmitter continuously senses the position of the piston.
It has an analogue output with an output signal relative to the piston position.

Ordering data – Position transmitter for T-slot

Datasheets → Internet: position transmitter

	Position measuring range	Analogue output		Type of mounting	Electrical connection	Cable length [m]	Part no.	Type
		[V]	[mA]					
	0 ... 40	0 ... 10	–	Inserted in the slot from above	Plug M8x1, 4-pin, in-line	0.3	553744	SMAT-8M-U-E-0.3-M8D



Ordering data – Position transmitter for T-slot

Datasheets → Internet: sdas

	Description	Type of mounting	Electrical connection	Cable length [m]	Part no.	Type
	Choice of two operating modes: • two adjustable switching outputs • IO-Link®	Inserted in the slot from above	Plug M8x1, 4-pin, in-line	0.3	8063974	SDAS-MHS-M40-1L-PNLK-PN-E-0.3-M8
			Cable, open end	2.5	8063975	SDAS-MHS-M40-1L-PNLK-PN-E-2.5-LE

Ordering data – Connecting cables

Datasheets → Internet: nebu

	Electrical connection, left	Electrical connection, right	Cable length [m]	Part no.	Type
	Straight socket, M8x1, 4-pin	Cable, open end, 4-core	2.5	541342	NEBU-M8G4-K-2.5-LE4
			5	541343	NEBU-M8G4-K-5-LE4
	Angled socket, M8x1, 4-pin	Cable, open end, 4-core	2.5	541344	NEBU-M8W4-K-2.5-LE4
			5	541345	NEBU-M8W4-K-5-LE4

Festo - Your Partner in Automation



1 Festo Inc.
5300 Explorer Drive
Mississauga, ON L4W 5G4
Canada

Festo Customer Interaction Center
Tel: 1 877 463 3786
Fax: 1 877 393 3786
Email: customer.service.ca@festo.com



2 Festo Pneumatic
Av. Ceylán 3,
Col. Tequesquináhuac
54020 Tlalnepantla,
Estado de México

Multinational Contact Center
01 800 337 8669
ventas.mexico@festo.com



3 Festo Corporation
1377 Motor Parkway
Suite 310
Islandia, NY 11749

Festo Customer Interaction Center
1 800 993 3786
1 800 963 3786
customer.service.us@festo.com



4 Regional Service Center
7777 Columbia Road
Mason, OH 45040

Connect with us



www.festo.com/socialmedia



www.festo.com

Subject to change