



- Strength in motion
- Precision measurement

# Standard cylinders DNCl, with integrated displacement encoder



# Standard cylinders DNCI, with measuring transducer DADE



Key features

**Components for positioning and measuring using the standard cylinder DNCI**

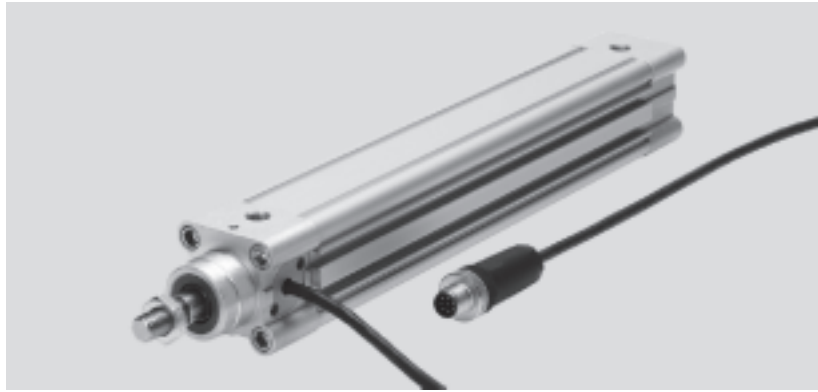

**Measuring with measuring transducer DADE**

**Measuring transducer DADE-...**  
→ 5 / 1.1-56



**PLC controller e.g. FEC-...**  
→ Volume 4



**Display and control unit e.g. FED-...**  
→ Volume 4



**Positioning with end-position controller SPC11 or axis controller SPC200**

**Proportional directional control valve MPYE-...**  
→ 5 / 1.5-2



**Soft Stop**  
→ 5 / 1.4-2

**Positioning technology**  
→ 5 / 1.3-2

**Closed loop end-position controller SPC11-INC**



**Axis interface SPC-AIF-INC**



**Axis controller SPC200**



**Servopneumatic positioning systems**  
Cylinders with displacement encoders

**1.1**

# Standard cylinders DNCI, with measuring transducer DADE

Type code

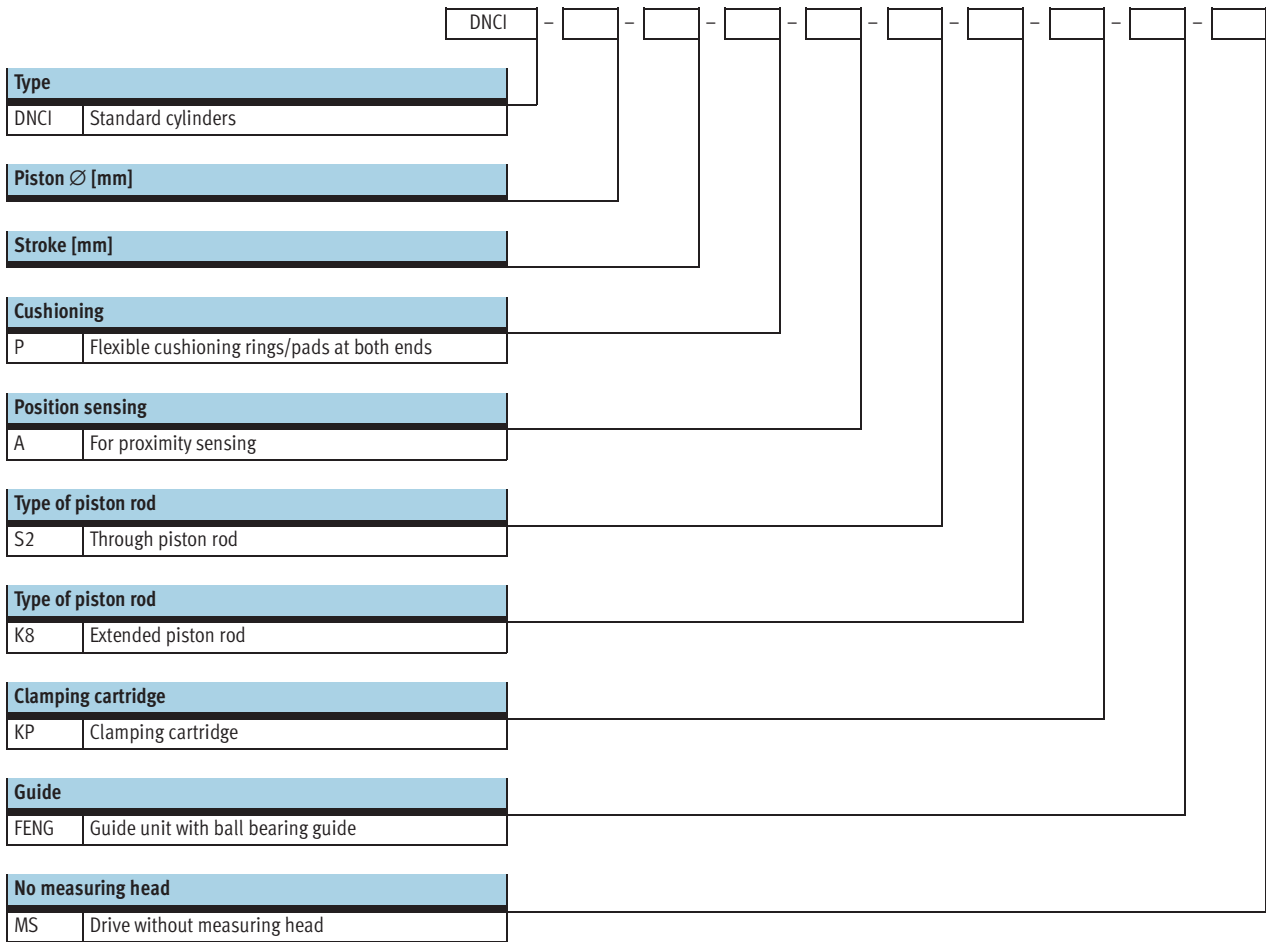

# Standard cylinders DNCI, with measuring transducer DADE

Peripherals overview

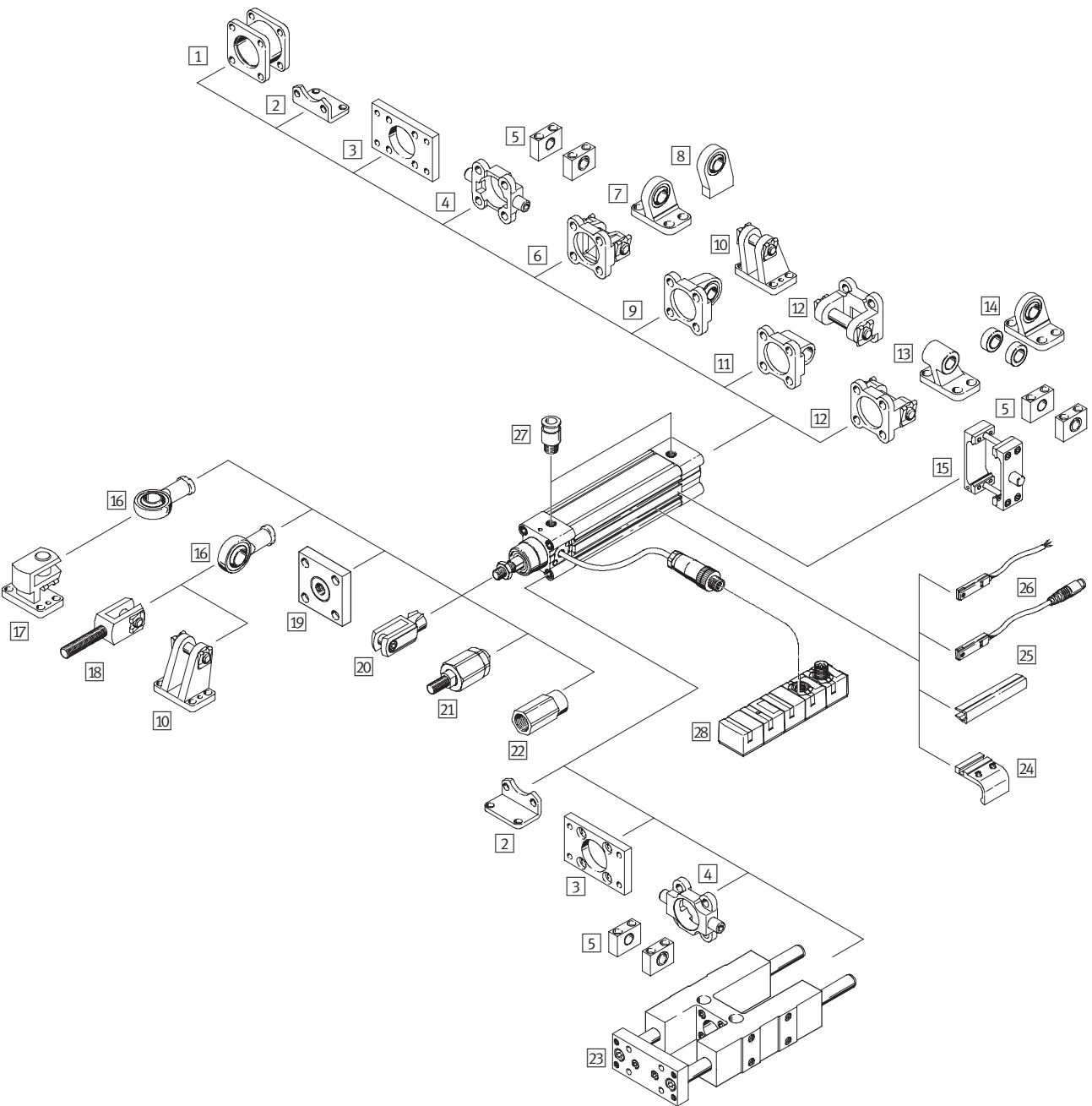

Accessories		
Type	Brief description	→ Page
1 Adapter kit <sup>1)</sup> DPNC	For connecting two cylinders with identical piston $\varnothing$ to form a multi-position cylinder	Volume 1
2 Foot mounting HNC	For mounting the drive on the bearing and end cap	Volume 1
3 Flange mounting FNC	For mounting the drive on the bearing and end cap	Volume 1
4 Trunnion mounting ZNCF/CRZNG	For swivelling movements of the drive on the bearing or end caps	Volume 1
5 Trunnion support LNZG/CRLNZG	–	Volume 1

# Standard cylinders DNCI, with measuring transducer DADE

Peripherals overview

FESTO

Accessories		
Type	Brief description	→ Page
6 Swivel flange <sup>1)</sup> SNC	For swivelling movements of the drive on the end cap	Volume 1
7 Clevis foot mounting <sup>1)</sup> LSNG	With spherical bearing	Volume 1
8 Clevis foot mounting <sup>1)</sup> LSNSG	Weld-on, with spherical bearing	Volume 1
9 Swivel flange <sup>1)</sup> SNCS	For swivelling movements of the drive on the end cap, with spherical bearing	Volume 1
10 Clevis foot mounting <sup>1)</sup> LBG	–	Volume 1
11 Swivel flange <sup>1)</sup> SNCL	For swivelling movements of the drive on the end cap	Volume 1
12 Swivel flange <sup>1)</sup> SNCB	For swivelling movements of the drive on the end cap	Volume 1
13 Clevis foot mounting <sup>1)</sup> LNG/CRLNG	–	Volume 1
14 Clevis foot mounting <sup>1)</sup> LSN	With spherical bearing	Volume 1
15 Trunnion mounting kit ZNCM	For swivelling movements of the drive	Volume 1
16 Rod eye SGS/CRSGS	With spherical bearing	Volume 1
17 Right-angle clevis foot LQG	–	Volume 1
18 Rod clevis SGA	With male thread	Volume 1
19 Coupling piece KSG	For compensating radial deviations	Volume 1
Coupling piece KSZ	For cylinders with a non-rotating piston rod to compensate for radial deviations	Volume 1
20 Rod clevis SG/CRSG	Permits a swivelling movement of the cylinder in one plane	Volume 1
21 Self-aligning rod coupler FK	For compensating radial and angular deviations	Volume 1
22 Adapter AD	For a vacuum suction cup	Volume 1
23 Guide unit FENG	For protecting standard cylinders from torsion at high torque loads	5 / 1.1-54
24 Mounting kit SMB-8-FENG	For mounting proximity sensors SME/SMT-8 in combination with guide unit FENG	Volume 1
25 Slot cover ABP-5-S	To protect the sensor cable and keep dirt out of the sensor slots	Volume 1
26 Proximity sensor SME/SMT-8	Can be integrated in the cylinder profile barrel	Volume 1
27 Push-in fitting QS	For connecting compressed air tubing with standard external diameters	Volume 3
28 Measuring transducer DADE-MVC	Converts sensor signals of the standard cylinder DNCI into one voltage signal of 0 ... 10 V and/or current signal of 0 ... 20 mA	5 / 1.1-56

1) Not with variants S2

2) Guide unit FENG-KF must be attached to the piston rod such that backlash is eliminated

# Standard cylinders DNCI, with measuring transducer DADE

Technical data

Function

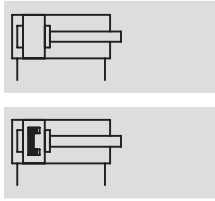

- - Diameter  
32 ... 63 mm
- - Stroke length  
10 ... 2,000 mm



General technical data				
Piston Ø	32	40	50	63
Constructional design	Piston Piston rod Profile barrel			
Mode of operation	Double-acting			
Cushioning	Flexible cushioning rings/pads at both ends			
Position sensing	Integrated displacement encoder For proximity sensing <sup>1)</sup>			
Measuring principle (displacement encoder)	Digital			
Type of mounting	Foot mounting			
Stroke [mm]	10 ... 2,000			
Torsion protection/Guide <sup>3)</sup>	Guide rod with yoke, with ball bearing guide			
Stroke [mm]	100 ... 500			
Piston rod extension [mm]	1 ... 500			
Pneumatic connection	G1/8	G1/4	G1/4	G3/8
Electrical connection	Cable with 8-pin plug, round type M12			
Cable length [m]	1.5			

- 1) Not included in the scope of delivery, can be ordered as an option
- 3) Guide unit FENG-KF must be ordered as an option and will be supplied attached, the max. stroke is reduced

Forces [N] and impact energy [Nm]				
Piston Ø	32	40	50	63
Theoretical force at 6 bar advancing	483	754	1,178	1,870
Theoretical force at 6 bar retracting	415	633	990	1,682
Impact energy at end positions	0.1	0.2	0.2	0.5

Permissible impact velocity:

$$v_{perm.} = \sqrt{\frac{2 \times E_{perm.}}{m_{dead} + m_{load}}}$$

- $v_{perm.}$  Permissible impact velocity
- $E_{perm.}$  Max. impact energy
- $m_{dead}$  Moving load (drive)
- $m_{load}$  Moving work load

Maximum permissible load:

$$m_{load} = \frac{2 \times E_{perm.}}{v^2} - m_{dead}$$

- Note

These specifications represent the maximum values which can be reached. Note the maximum permitted impact energy.

# Standard cylinders DNCI, with measuring transducer DADE

Technical data



Operating and environmental conditions		
Operating pressure	[bar]	0.6 ... 12
Operating medium <sup>2)</sup>		Compressed air, filtered and unlubricated, filter unit 5 µm
Ambient temperature <sup>3)</sup>	[°C]	-20 ... +80
Vibration resistance		To DIN/IEC 68 Parts 2 – 6, severity level 2
Continuous shock resistance		To DIN/IEC 68 Parts 2 – 82, severity level 2
CE symbol (declaration of conformance)		In accordance with EU EMC Directive
Protection class (displacement encoder)		IP65 to IEC 60 529
Corrosion resistance class CRC <sup>4)</sup>		1

2) The proportional directional control valve MPYE used requires the characteristic values

3) Note operating range of proximity sensors

4) Corrosion resistance class 1 according to Festo standard 940 070

Components requiring low corrosion resistance. Transport and storage protection. Parts that do not have primarily decorative surface requirements, e.g. in internal areas that are not visible or behind covers.

Weights [g] with displacement encoder					
Piston Ø		32	40	50	63
Basic drive DNCI-...					
	Product weight with 0 mm stroke	521	853	1,319	1,914
	Additional weight per 10 mm stroke	30	44	62	71
	Moving load with 0 mm stroke	95	175	316	383
	Additional weight per 10 mm stroke	8	14	23	23
Drive with through piston rod DNCI-...-S2					
	Product weight with 0 mm stroke	586	981	1,553	2,165
	Additional weight per 10 mm stroke	39	60	87	96
	Moving load with 0 mm stroke	155	164	297	364
	Additional weight per 10 mm stroke	17	30	48	48
Additional weight with extended piston rod K8					
	Additional weight per 10 mm stroke	8	14	23	23
Additional weight with clamping cartridge KP					
	Product weight	234	394	700	1,147
Additional weight with guide unit FENG-...					
	Product weight with 0 mm stroke	1,530	2,370	4,030	5,410
	Additional weight per 10 mm stroke	18	32	50	62

## Materials

Sectional view

Standard cylinders		
1	Piston rod	High-alloy steel
2	Cylinder barrel	Anodised aluminium
3	Bearing/end caps	Die-cast aluminium
-	Dynamic seals	Polyurethane TPE-U
-	Static seals	Nitrile rubber
-	Lubricant	Klüberplex BE31-102
Displacement encoder		
-	Sensor housing	Polyacetate
-	Cable sheath	Polyurethane
-	Plug housing	Polybuteneterephthalate
-	Wall mounting plate	Polyacetate
-	Screws for mounting plate	Steel

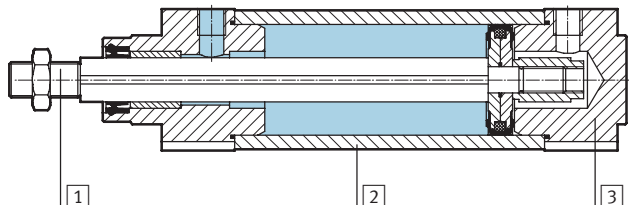



# Standard cylinders DNCl, with measuring transducer DADE

Technical data

Electrical data, displacement encoder		
Linearity error <sup>1)</sup>	[mm]	$\pm(0.07 \pm 0.02 \times L)$
Max. speed of travel	[m/s]	1.5
Ambient temperature	[°C]	-20 ... +80
Max. temperature coefficient	[ppm/°K]	30
Protection class		IP65
CE symbol (declaration of conformance)		In accordance with EU EMC Directive
Max. permitted magnetic disruption field at 100 mm interval from the sensor <sup>2)</sup>	[kA/m]	10
Electrical connection		Cable with 8-pin plug, round type M12
Cable length	[m]	1.5

- 1) Maximum deviation of the output signal from "best fit" line (characteristic curve with nominal gradient).  
L = Length of measuring system in meters
- 2) See also mounting conditions

# Standard cylinders DNCI, with measuring transducer DADE

Technical data



## Torques and lateral forces

The piston rod must not absorb any torque. We therefore recommend that an external guide FENG-KF be used with the drive DNCI. The guide unit is delivered installed.

The permissible static and dynamic characteristic load values with and without attached guide as well as with regard to the technical data of the variants (S2, S8, S9)

→ Volume 1 (standard cylinder DNC)

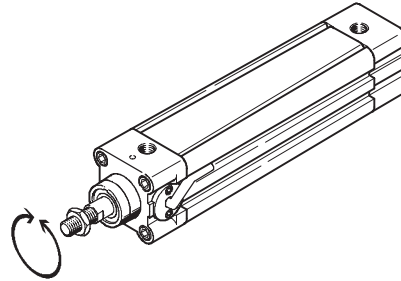

## Mounting conditions

When mounting a drive A with magnet (for position sensing), in addition to a standard cylinder DNCI, the following conditions must be observed:

- X Minimum distance between the drives
- Y Offset between the drives on the bearing cap

### Parallel assembly

If the offset  $Y = 0$  mm, the drives can be assembled directly next to one another.

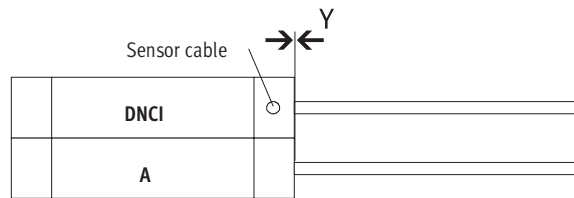

### Offset assembly, cable outlet between the drives

If the offset  $Y > 0$  mm and the cable outlet is between the drives, the distance from  $X > 70$  mm must be observed.

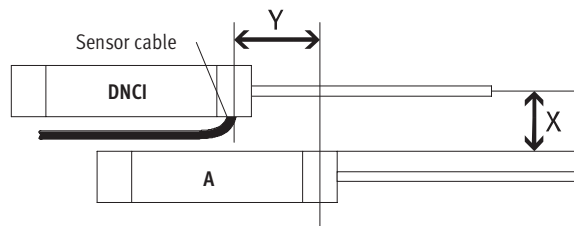

### Offset assembly, cable outlet upwards or downwards

If the offset  $Y > 0$  mm and the cable outlet is up or down, the distance from  $X > 60$  mm must be observed.

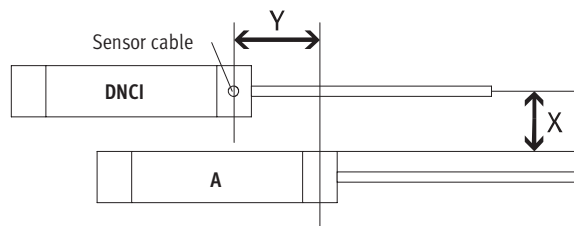

## Pin assignment of plug, view of plug

Pin	Function	Colour
1	5 V	black
2	GND	brown
3	sin+	red
4	sin-	orange
5	cos-	green
6	cos+	yellow
7	Screening	Screening
8	-	-

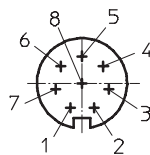

# Standard cylinders DNCI, with measuring transducer DADE

Technical data



**Dimensions** Download CAD data → [www.festo.com/en/engineering](http://www.festo.com/en/engineering)  
 Basic version

1 Socket head screw with female thread for mounting attachments  
 2 Hole for securing the earthing self-tapping M4 screw according to DIN 7500  
 3 Sensor slot for proximity sensor SME/SMT-8  
 4 Magnetic measuring band

+ = plus stroke length  
 ++ = plus 2x stroke length

S2 – Through piston rod

+ = plus stroke length  
 ++ = plus 2x stroke length

S2 / KP – Through piston rod with clamping cartridge

K8 – Extended piston rod

# Standard cylinders DNCl, with measuring transducer DADE

FESTO

Technical data

∅ [mm]	AM	A2 max.	B ∅ d11	BG	D1 ∅ f9	D2	D7 ∅	E	EE	G	H1
32	22	500	30	16	20	M5	3.7	45	G $\frac{1}{8}$	28	67
40	24	500	35	16	24	G $\frac{1}{8}$	3.7	54	G $\frac{1}{4}$	33	88
50	32	500	40	17	30	G $\frac{1}{8}$	3.7	64	G $\frac{1}{4}$	33	107
63	32	500	45	17	38	G $\frac{1}{8}$	3.7	75	G $\frac{3}{8}$	40.5	123

∅ [mm]	KK	L1	L2	L3	L5	L9	MM ∅ f8	PL	RT	T1	TG
32	M10x1.25	18	94	45	14	22.5	12	15.6	M6	8	32.5
40	M12x1.25	21.3	105	53	16	27	16	14	M6	8	38
50	M16x1.5	26.8	106	67	20	27	20	14	M8	8	46.5
63	M16x1.5	27	121	76	24	33	20	17	M8	8	56.5

∅ [mm]	PI	VD	WH	ZJ		ZM		≈C1	≈C2	≈C3
					KP		KP			
32	4	10	26	120	165	148	193	10	16	6
40	4	10.8	30	135	188	167	220	13	18	6
50	4	14.3	37	143	210	183	250	17	24	8
63	4	14.5	37	158	234	199	275	17	24	8

# Standard cylinders DNCl, with measuring transducer DADE

Technical data



## Dimensions

Download CAD data → [www.festo.com/en/engineering](http://www.festo.com/en/engineering)

Guide unit FENG-KF

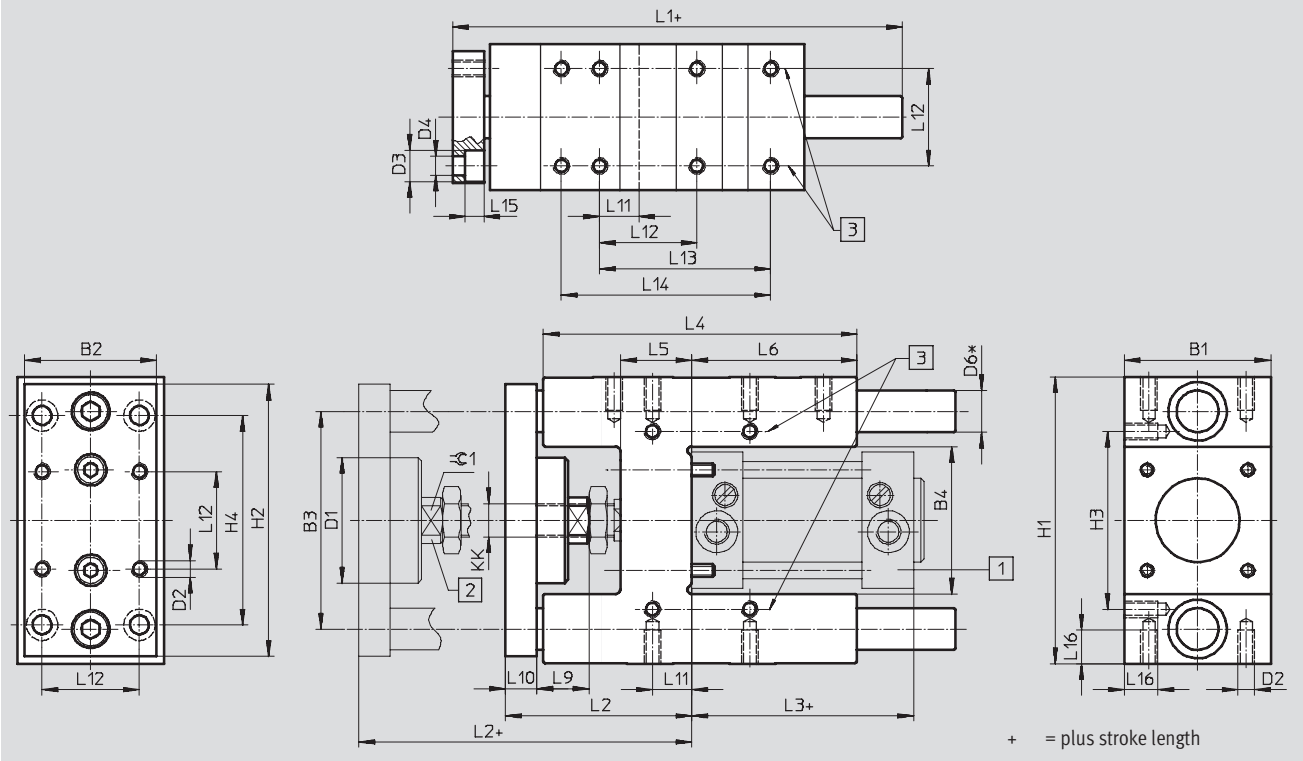

# Standard cylinders DNCl, with measuring transducer DADE

FESTO

Technical data

For Ø	B1	B2	B3	B4	D1	D2	D3	D4	D6	H1
[mm]	-0.3		±0.2	±0.3	∅		∅	∅	∅	h6
32	50	45	74	50.5	44	M6	11	6.6	12	97 <sub>-0.4</sub>
40	58	54	87	58.5	44	M6	11	6.6	16	115 <sub>-0.4</sub>
50	70	63	104	70.5	60	M8	15	9	20	137 <sub>-0.5</sub>
63	85	80	119	85.5	60	M8	15	9	20	152 <sub>-0.5</sub>

For Ø	H2	H3	H4	KK	L1	L2	L3	L4	L5	L6
[mm]		±0.2	±0.2							
32	90	61	78	M10x1.25	155	67 <sub>+5</sub>	94	125	24	76
40	110	69	84	M12x1.25	170	75 <sub>+5</sub>	105	140	28	81
50	130	85	100	M16x1	188	89 <sub>+10</sub>	106	150	34	79
63	145	100	105	M16x1	220	89 <sub>+10</sub>	121	182	34	111

For Ø	L9	L10	L11	L12	L13	L14	L15	L16	≈G1
[mm]				±0.2	±0.2	±0.2			
32	20	12	4.3	32.5	70.3	78	6.5	12	15
40	22	12	11	38	84	–	6.5	14	15
50	25	15	18.8	46.5	81.8	100	9	16	19
63	25	15	15.3	56.5	105	–	9	16	19

# Standard cylinders DNCI, with measuring transducer DADE

Ordering data – Modular products



Servopneumatic positioning systems  
 Cylinders with displacement encoders

## 1.1

**M** Mandatory data →

Module No.	Function	Piston Ø	Stroke	Cushioning	Position sensing
535 411	DNCI	32	10 ... 2,000	P	A
535 412		40			
535 413		50			
535 414		63			
<b>Order example</b>					
<b>535 411</b>	<b>DNCI</b>	<b>- 32</b>	<b>- 100</b>	<b>- P</b>	<b>- A</b>

Ordering table								
Piston Ø	32	40	50	63	Condi- tions	Code	Enter code	
<b>M</b>	<b>Module No.</b>	<b>535 411</b>	<b>535 412</b>	<b>535 413</b>	<b>535 414</b>			
	<b>Function</b>	Standard cylinder with integrated displacement encoder, non-rotating piston rod					<b>DNCI</b>	DNCI
	Piston Ø [mm]	32	40	50	63		-...	
	Stroke [mm]	10 ... 2,000					-...	
	Cushioning	Flexible cushioning rings/pads at both ends					<b>-P</b>	-P
<b>↓</b>	Position sensing	For proximity sensing					<b>-A</b>	-A

Transfer order code

	<b>DNCI</b>	-		-		-	<b>P</b>	-	<b>A</b>	-
--	-------------	---	--	---	--	---	----------	---	----------	---

# Standard cylinders DNCI, with measuring transducer DADE

Ordering data – Modular products

**0 Options**

Type of piston rod	Piston rod extended at front	Clamping unit	Guide	Measuring head
S2	...K8	KP	FENG	MS

**Ordering table**

Piston Ø	32	40	50	63	Condi- tions	Code	Enter code
0 Type of piston rod	Through piston rod					-S2	
Piston rod extended [mm]	1 ... 500				2	-...K8	
Clamping unit	Clamping cartridge				3	-KP	
Guide	Guide unit with ball bearing guide on the sensor head side				4	-FENG	
Measuring head	No measuring head					-MS	

- 2 **K8** In combination with piston rod type S2, the piston rod is only extended at the front (the side facing the measuring head)
- 3 **K9** Only with piston rod type S2
- 4 **FENG** Maximum stroke length 500 mm

Transfer order code

- [ ] - [ ] - [ ] - [ ] - [ ] - [ ]



# Standard cylinder DNCl, with transducer DADE

Technical data



## Measuring transducer

**DADE-MVC-010**

**DADE-MVC-420**

The transducer converts sensor signals of the DNCl standard cylinder into a voltage signal of 0 ... 10 V or a current signal of 0 ... 20 mA. These signals can be evaluated by a PLC with an appropriate signal input.



General technical data		
Type of mounting	Via through holes	
Mounting position	Any	
Repetition accuracy in relation to effective stroke	≤ 400	±0.1 mm
	≤ 750	±0.2 mm
	≤ 1,200	±0.3 mm
	≤ 1,600	±0.4 mm
	≤ 2,000	±0.5 mm
Protection against short circuit	Yes	
Protection against polarity reversal	Yes	
Diagnostic function	Display via LED	

General electrical data		
Analogue output	[V]	0 ... 10 (as per EN 61131-2)
	[mA]	0 ... 20 (as per EN 61131-2)
Nominal operating voltage	[V DC]	24 ±25%
Residual ripple	[%]	4 (at 50 Hz)
Current consumption at nominal operating voltage	[mA]	20 ... 30
Switching logic at outputs	PNP	
Switching logic at inputs	PNP	
Debounce time at inputs	[ms]	3
Linearity error FS	0,2%	

Operating and environmental conditions		
Ambient temperature	[°C]	0 ... 55
Protection class	IP65	
Relative air humidity	95% non-condensing	
CE symbol (see conformity declaration)	As per EU EMC directive	
Corrosion resistance class CRC <sup>1)</sup>	1	
Product weight	[g]	128
Note on material for housing	Polybutylene terephthalate	

1) Corrosion resistance class 1 as per Festo standard 940 070  
Components requiring low corrosion resistance Transport and storage protection. Parts that do not have primarily decorative surface requirements, e.g. in internal areas that are not visible or behind covers

# Standard cylinder DNCl, with transducer DADE

Technical data



Dimensions Download CAD data → [www.festo.com/en/engineering](http://www.festo.com/en/engineering)

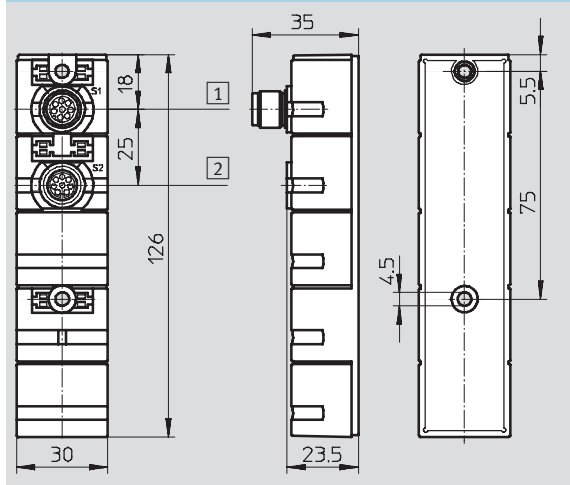

1 PLC interface:  
8-pin M12, male

2 Measuring system interface:  
8-pin M12, female

## Pin allocation

PLC interface

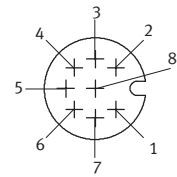

Measuring system interface

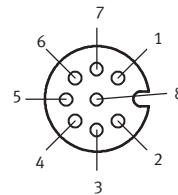

Pin	Function	Cable colour
1	24 V	white
2	Measured signal (analogue)	brown
3	Reference output	green
4	0 V measured signal	yellow
5	Reference input	grey
6	Calibration input	pink
7	Ready output	blue
8	0 V power supply and inputs/ outputs	red

Pin	Function
1	Ub
2	0 V
3	Signal sine +
4	Signal sine -
5	Signal cosine -
6	Signal cosine +
7	Screening / earth
8	-

## Ordering data

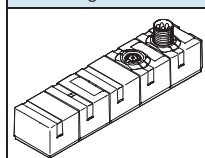
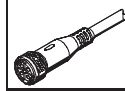
	Description	Part No.	Type
<b>Measuring transducer</b>			
	With voltage signal	0 ... 10 V	542 117 DADE-MVC-010
	With current signal	0 ... 20 mA	542 118 DADE-MVC-420
<b>Accessories</b>			
	Cable with socket	Connecting cable to PLC (length 2 m)	525 616 SIM-M12-8GD-2-PU
		Connecting cable to PLC (length 5 m)	525 618 SIM-M12-8GD-5-PU