



- Compact
- Functional
- Multiple variants
- Versatile

# Drive/drive connectors

Key features



System components  
Adapters

3.2

## At a glance

Compact	Functional	Versatile	Individual
<ul style="list-style-type: none"> <li>• Drive combinations with harmonised connecting kits</li> <li>• Sturdy kits for accurate and reliable drive combinations</li> </ul>	<ul style="list-style-type: none"> <li>• With the numerous adapter kit variants on offer a wealth of combination options is available</li> <li>• With linear movements in every direction, supplemented by rotary movements, almost any desired application can be realised</li> </ul>	<ul style="list-style-type: none"> <li>• Combination of different Festo drives into one complete system</li> <li>• All the parts required for the combination are included in the scope of delivery</li> </ul>	<ul style="list-style-type: none"> <li>• Application-oriented combinations can be selected:                             <ul style="list-style-type: none"> <li>– Direct mounting</li> <li>– Dovetail mounting</li> </ul> </li> </ul>

## The system

### Definition of axes

To determine the drive, the movement mounting position, the movement planes are defined in the y and z axes. plane and thus the axis designation (y or x) may change.

### Y/Z axis

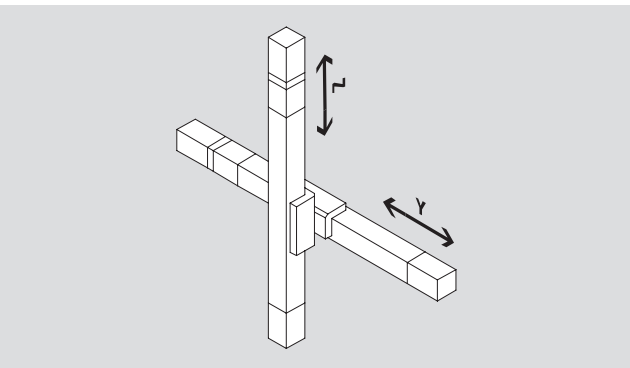

### X/Y axis

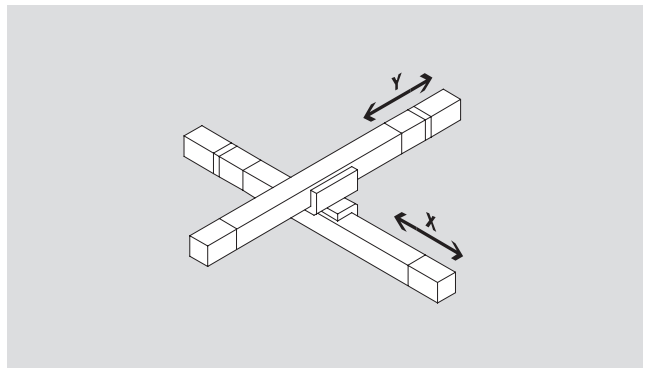

### X/Y/Z axis

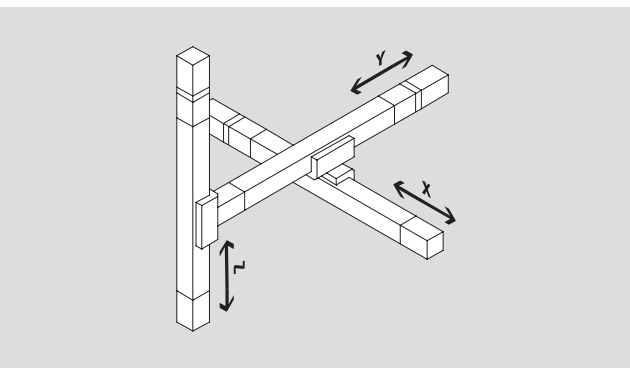

# Drive/drive connectors

Key features



## Types of connection

### Direct mounting

Two drives are connected directly using screws and centring sleeves or via an adapter plate using screws and centring sleeves.

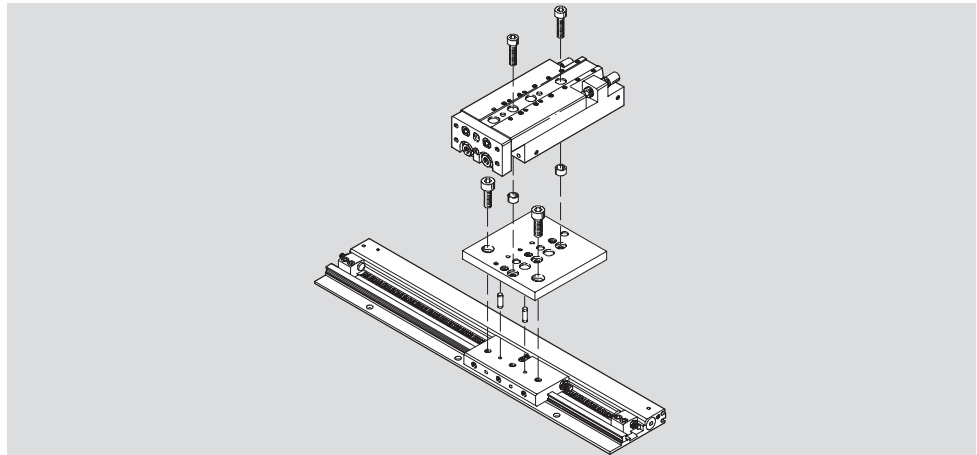

### Dovetail mounting

Two drives are connected using a dovetail clamping device and possibly also an adapter plate.

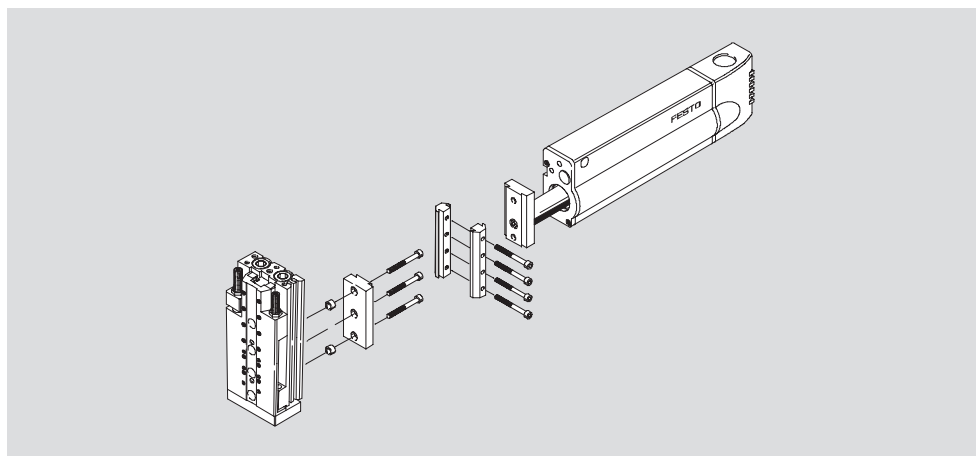

## Assembly

For the quick connection of two drives, the required screws, centring sleeves, centring pins, clamping components, adapter plates and slot nuts are contained in the scope of delivery of the adapter kit.

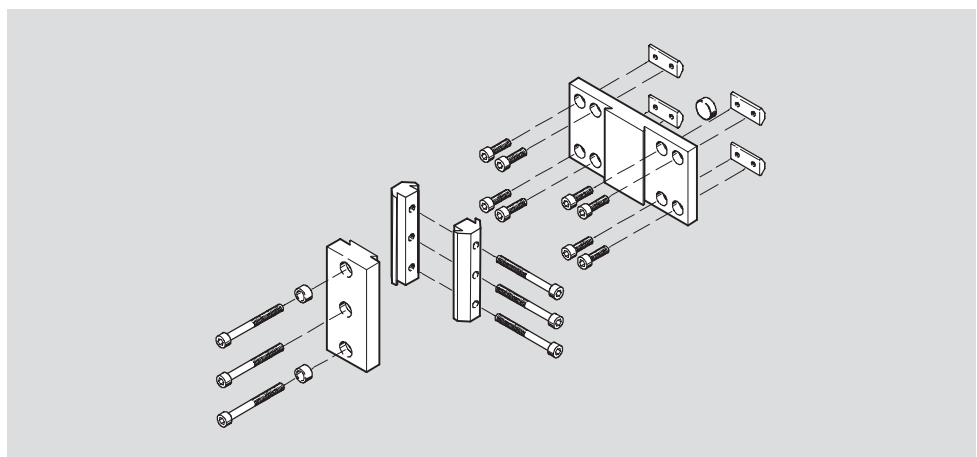

# Drive/drive combinations

Selection aid



Adapter kits provide a fast, sturdy and precise connection between Festo grippers and drives.

The scope of delivery includes all necessary accessories such as bolts, centring discs, sleeves or pins and nuts.

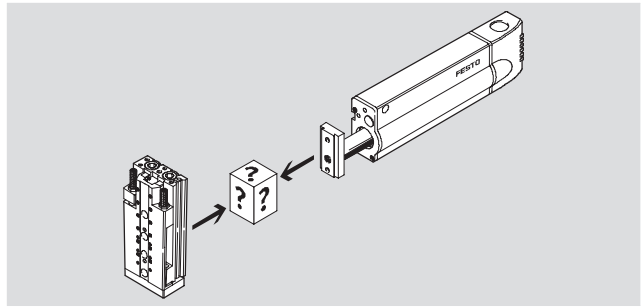

System components  
Adapters

3.2

Possible combinations						
	X/Y					
	HMP, HME	HMPL	DGSL	SLT, SLTE	SLG	
Z	 → 5 / 3.2-6	–	–	–	–	–
	 → 5 / 3.2-8	→ 5 / 3.2-15		–		–
	 → 5 / 3.2-10	–	→ 5 / 3.2-17	–		→ 5 / 3.2-21
	 → 5 / 3.2-11	–	–	→ 5 / 3.2-19		→ 5 / 3.2-22
	 –	–	–	–		→ 5 / 3.2-23
	 → 5 / 3.2-12	→ 5 / 3.2-16	→ 5 / 3.2-18	→ 5 / 3.2-20		–
	 → 5 / 3.2-14	–	–	–		–

# Drive/drive combinations

Selection aid



Adapter kits provide a fast, sturdy and precise connection between Festo grippers and drives.

The scope of delivery includes all necessary accessories such as bolts, centring discs, sleeves or pins and nuts.

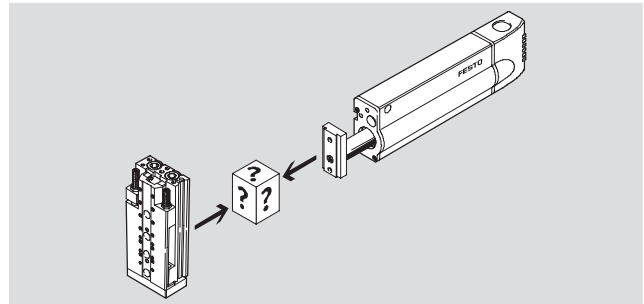

Possible combinations						
	X/Y					
	DRQD	DGPL/DGE-KF	DG...-HD	SPZ	DPZ	
Z		→ 5 / 3.2-24	→ 5 / 3.2-26	→ 5 / 3.2-39	-	-
		→ 5 / 3.2-24	→ 5 / 3.2-27	-	-	-
		→ 5 / 3.2-18	→ 5 / 3.2-28	-	-	-
		→ 5 / 3.2-24	→ 5 / 3.2-29	-	-	-
		-	→ 5 / 3.2-30	-	-	-
		-	→ 5 / 3.2-32	-	-	-
		-	→ 5 / 3.2-32	-	-	-
		-	→ 5 / 3.2-33	-	-	-
		-	-	-	→ 5 / 3.2-40	→ 5 / 3.2-40
		-	→ 5 / 3.2-34	-	→ 5 / 3.2-40	→ 5 / 3.2-40
		-	→ 5 / 3.2-35	-	-	-

# HMP, HME/HMP combination

Technical data



## Adapter kit HMSV

Material:  
Wrought aluminium alloy, anodised  
Centring sleeves: High-alloy steel  
Slot nuts: Tempered steel  
Free of copper, PTFE and silicone

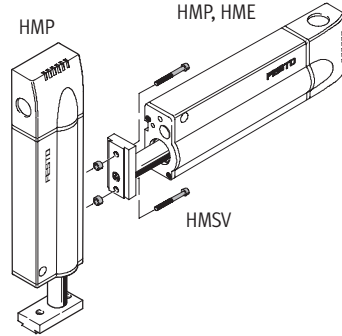

Direct mounting

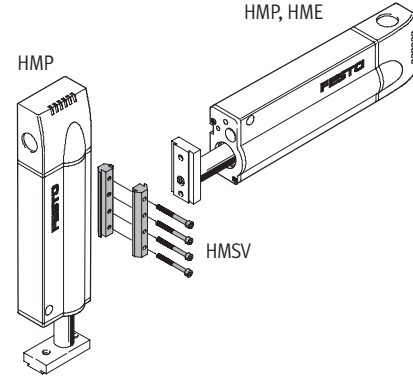

Dovetail mounting

System components  
Adapters

3.2

## Dimensions and ordering data

Download CAD data → [www.festo.com/en/engineering](http://www.festo.com/en/engineering)

### Direct mounting

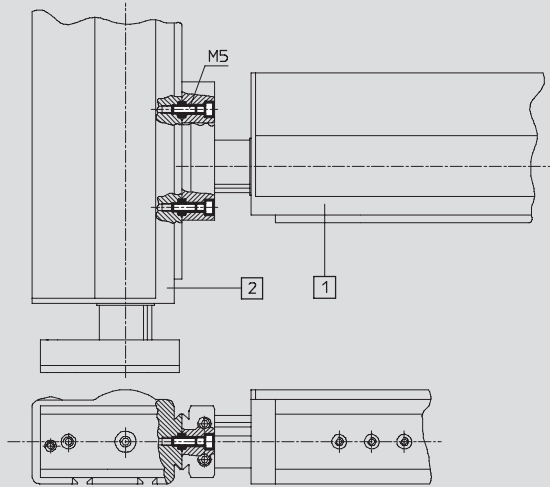

- 1 Linear module HMP, HME<sup>2)</sup>
- 2 Linear module HMP

Drive	Drive	CRC <sup>1)</sup>	Part No.	Type
1	2			
HMP/HME-16 <sup>2)</sup>	HMP-16	2	177 648	HMSV-2
HMP-20	HMP-16/20		177 650	HMSV-4
HMP-25/32	HMP-16/20		177 651	HMSV-5
HME-25 <sup>2)</sup>				
HMP/HME-25 <sup>2)</sup>	HMP-25		177 652	HMSV-6
HMP-32	HMP-25/32			

1) Corrosion resistance class 2 to Festo standard 940 070  
Components subject to moderate corrosion stress. Externally visible parts with primarily decorative surface requirements which are in direct contact with a normal industrial environment or media such as coolants or lubricating agents

2) HME: Horizontal mounting position, vertical on request

# HMP, HME/HMP combination

Technical data

Dimensions and ordering data Download CAD data → [www.festo.com/en/engineering](http://www.festo.com/en/engineering)

Dovetail mounting

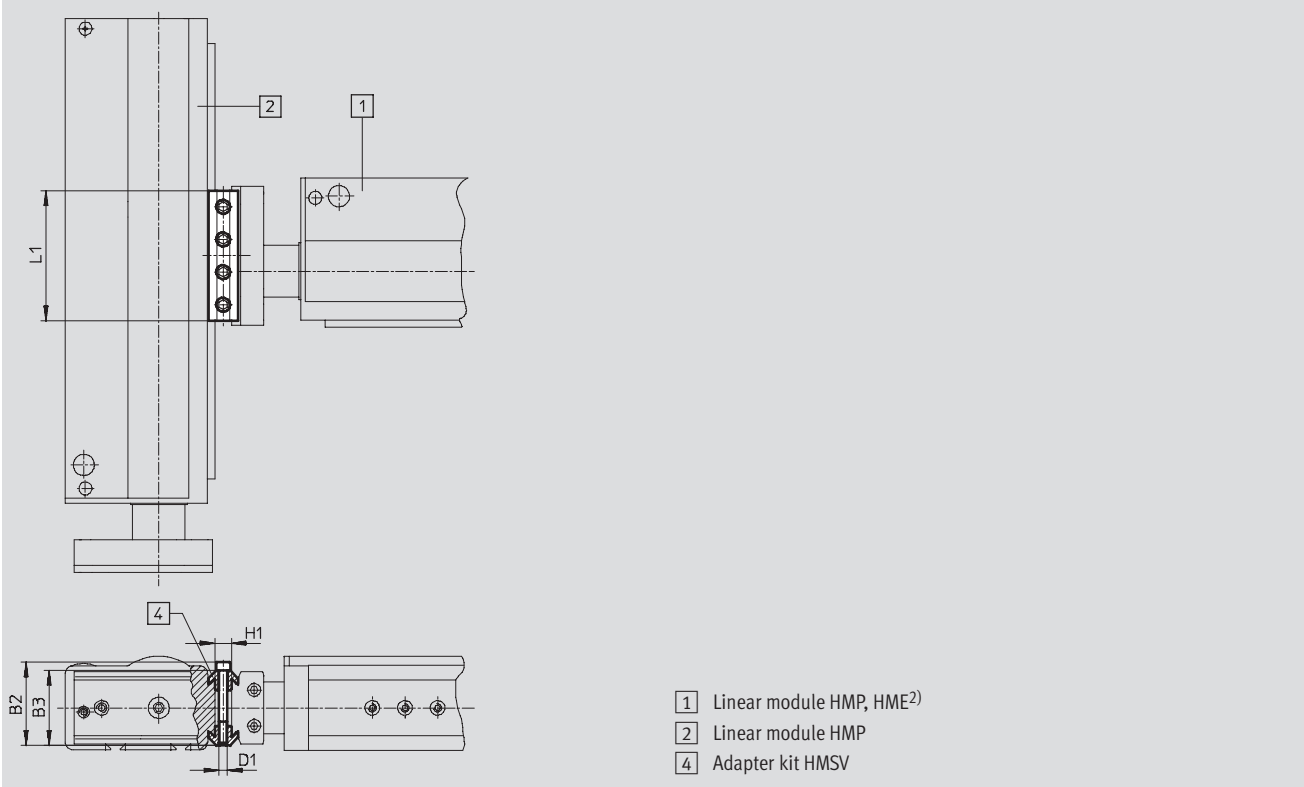

Drive 1	Drive 2	B2	B3	D1	H1	L1	CRC <sup>1)</sup>	Part No.	Type
HMP-16/20/25 HME-16/25 <sup>2)</sup>	HMP-16	51	46	M5	10	80	2	177 647	HMSV-1
HMP-20 HMP/HME-25 <sup>2)</sup>	HMP-20 HMP-20/25					100		177 649	HMSV-3
HMP-32	HMP-16 HMP-20/25/32					120		177 653	HMSV-7

1) Corrosion resistance class 2 to Festo standard 940 070  
 Components subject to moderate corrosion stress. Externally visible parts with primarily decorative surface requirements which are in direct contact with a normal industrial environment or media such as coolants or lubricating agents

2) HME: Horizontal mounting position, vertical on request

# HMP, HME/HMPL combination

Technical data



## Adapter kit HMSV

Material:  
Wrought aluminium alloy, anodised  
Centring sleeves: High-alloy steel  
Free of copper, PTFE and silicone

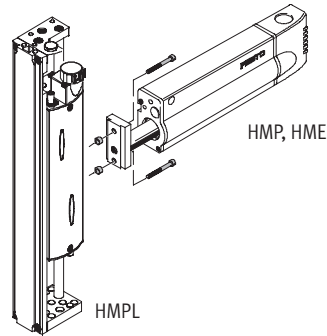

Direct mounting

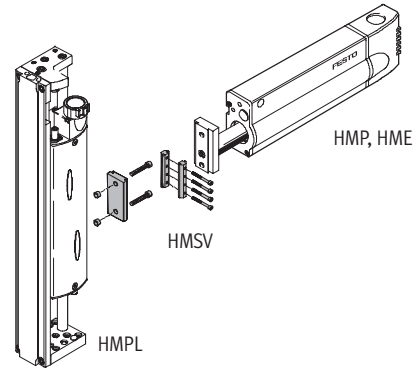

Dovetail mounting

## Dimensions and ordering data

Download CAD data → [www.festo.com/en/engineering](http://www.festo.com/en/engineering)

### Direct mounting

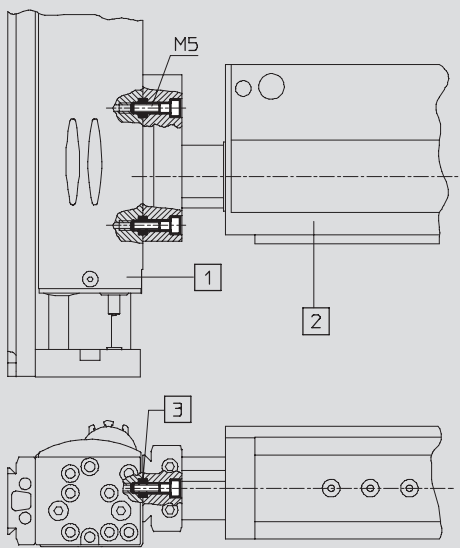

- 1 Linear module HMPL
- 2 Linear module HMP, HME
- 3 Centring sleeve ZBH-9

Drive	Drive	Part No.	Type	Required quantity	PU <sup>2)</sup>
HMP-16/20	HMPL-12/16/20	–	M5x22 DIN 912 <sup>1)</sup>	2	–
HME-16		150 927	ZBH-9	2	10
HMP/HME-25	HMPL-16/20	–	M5x30 DIN 912 <sup>1)</sup>	2	–
		150 927	ZBH-9	2	10

- 1) The screws listed are not included with the drives
- 2) Packaging unit quantity



# HMP, HME/HMPL combination

Technical data



## Dimensions and ordering data

Download CAD data → [www.festo.com/en/engineering](http://www.festo.com/en/engineering)

### Dovetail mounting

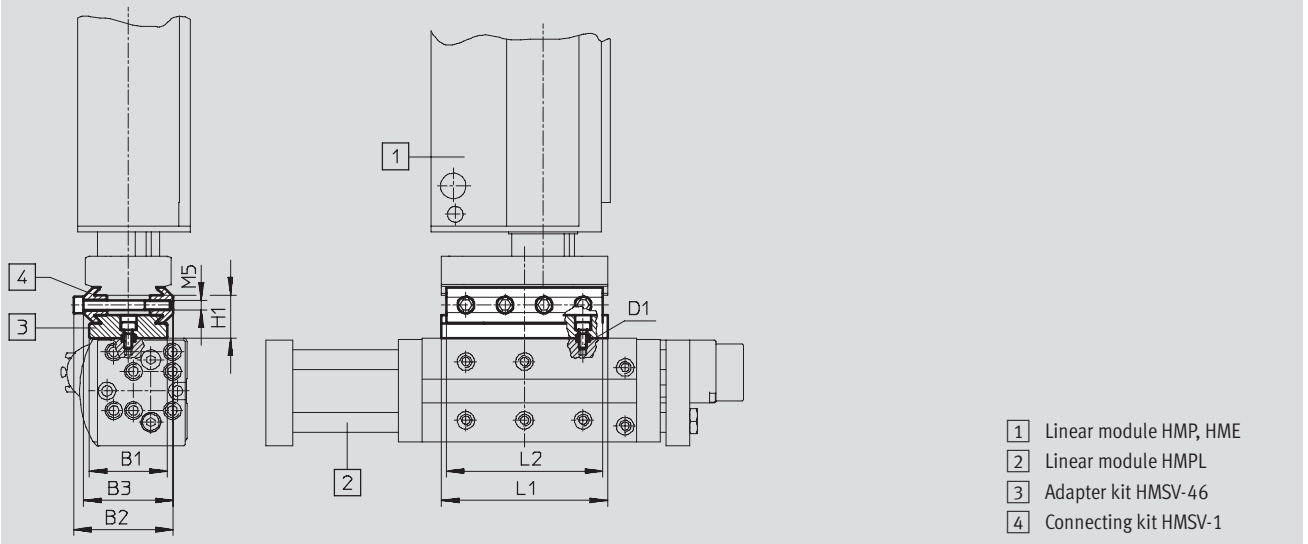

Drive	Drive	B1	B2	B3	D1	H1	L1	L2	CRC <sup>1)</sup>	Part No.	Type
HMP-16/20	HMPL-12/16/20	40	51	46	M3	22	85	80	2	193 923	HMSV-46
HME-16	HMPL-16/20									177 647	HMSV-1
HMP/HME-25	HMPL-16/20										
HMP-32	HMPL-20										

1) Corrosion resistance class 2 to Festo standard 940 070  
 Components subject to moderate corrosion stress. Externally visible parts with primarily decorative surface requirements which are in direct contact with a normal industrial environment or media such as coolants or lubricating agents

# HMP, HME/DGSL combination

Technical data



## Adapter kit HMSV

Material:  
Wrought aluminium alloy, anodised  
Centring sleeves: High-alloy steel  
Free of copper, PTFE and silicone

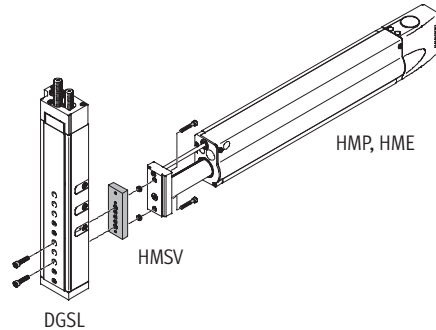

Direct mounting

## Dimensions and ordering data

Download CAD data → [www.festo.com/en/engineering](http://www.festo.com/en/engineering)

Direct mounting

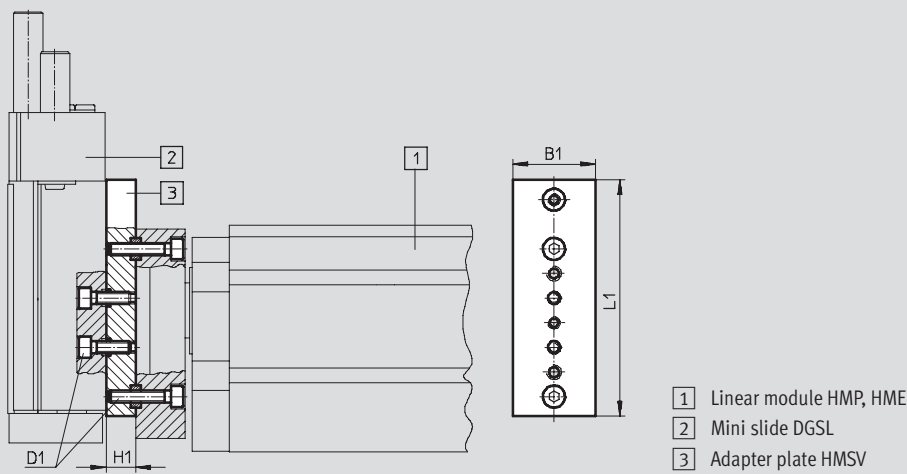

Drive	Drive	B1	D1	H1	L1	CRC <sup>1)</sup>	Part No.	Type
HMP/HME-16	DGSL-16	33.6	M5	12	96	2	548 779	HMSV-49
HMP-20	DGSL-16/20							
HMP/HME-25	DGSL-20/25							
HMP-32	DGSL-25							

1) Corrosion resistance class 2 to Festo standard 940 070

Components subject to moderate corrosion stress. Externally visible parts with primarily decorative surface requirements which are in direct contact with a normal industrial environment or media such as coolants or lubricating agents

# HMP, HME/SLT, SLTE combination

Technical data



## Adapter kit HMSV

Material:  
Wrought aluminium alloy, anodised  
Centring sleeves: High-alloy steel  
Free of copper, PTFE and silicone

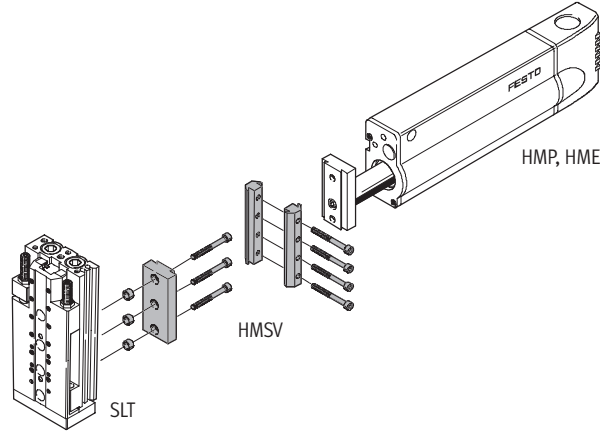

Dovetail mounting

## Dimensions and ordering data

Download CAD data → [www.festo.com/en/engineering](http://www.festo.com/en/engineering)

Dovetail mounting

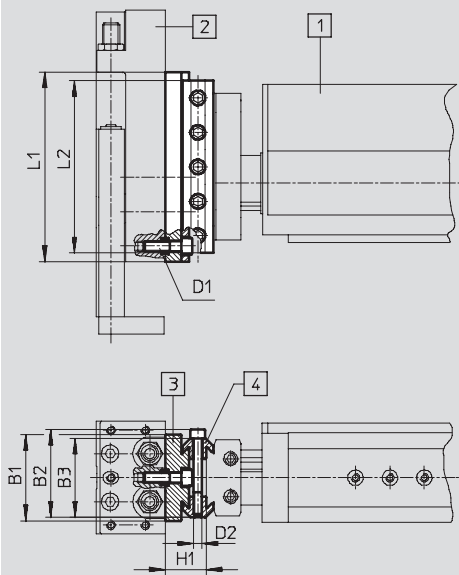

- 1 Linear module HMP, HME
  - 2 Mini slide SLT, SLTE
- Adapter kit HMSV, comprising:
- 3 Adapter plate
  - 4 Dovetail clamp

Drive	Drive	B1	B2	B3	D1	D2	H1	L1	L2	CRC <sup>1)</sup>	Part No.	Type
HMP/HME-16	SLT-6	40	51	46	M3	M5	22	85	80	2	178 329	HMSV-34
HMP-16/20 HME-16	SLT/SLTE-10				M4						178 330	HMSV-35
HMP-16/20/25 HME-16/25	SLT/SLTE-16	50			24		110	100	178 331		HMSV-36	
HMP-20/25/32 HME-25	SLT-20	80			M6		26	100	178 332		HMSV-37	
HMP-25/32 HME-25	SLT-25				M8							

1) Corrosion resistance class 2 to Festo standard 940 070

Components subject to moderate corrosion stress. Externally visible parts with primarily decorative surface requirements which are in direct contact with a normal industrial environment or media such as coolants or lubricating agents

# HMP, HME/DRQD combination

Technical data



## Adapter kit HMSV

Material:  
Wrought aluminium alloy, anodised  
Centring sleeves: High-alloy steel  
Free of copper, PTFE and silicone

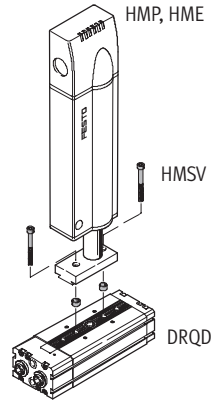

Direct mounting

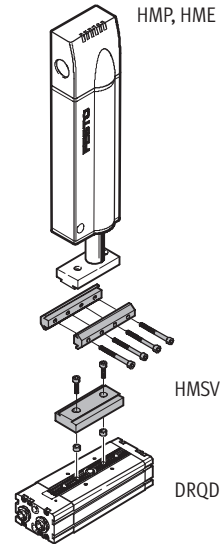

Dovetail mounting

## Dimensions and ordering data

Download CAD data → [www.festo.com/en/engineering](http://www.festo.com/en/engineering)

Direct mounting

HMSV-4/-5

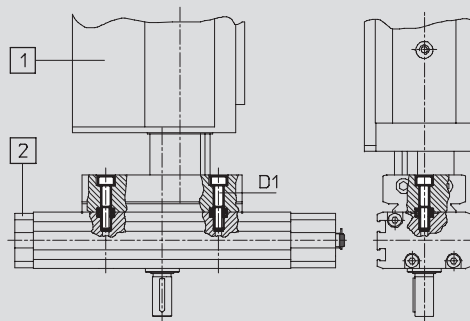

HMSV-11/-13/-15/-17

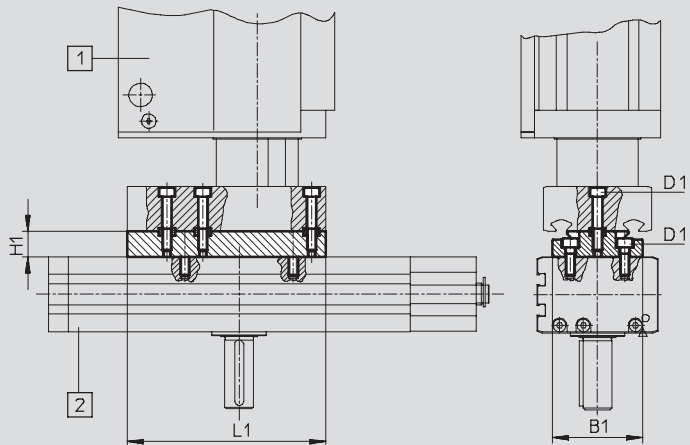

- 1 Linear module HMP, HME<sup>2)</sup>
- 2 Semi-rotary drive DRQD

Drive	Drive	B1	D1	H1	L1	CRC <sup>1)</sup>	Part No.	Type
HMP-16/20 HME-16 <sup>2)</sup>	DRQD-16/20	-	M5	-	-	2	177 650	HMSV-4
HMP/HME-25 <sup>2)</sup>	DRQD-16/20						177 651	HMSV-5
HMP-32	DRQD-25	50	M5	14	110	2	177 657	HMSV-11
	DRQD-25				133		177 659	HMSV-13
	DRQD-32				177 661		HMSV-15	
							177 663	HMSV-17

- 1) Corrosion resistance class 2 to Festo standard 940 070  
Components subject to moderate corrosion stress. Externally visible parts with primarily decorative surface requirements which are in direct contact with a normal industrial environment or media such as coolants or lubricating agents
- 2) HME: Horizontal mounting position, vertical on request

# HMP, HME/DRQD combination

Technical data



Dimensions and ordering data Download CAD data → [www.festo.com/en/engineering](http://www.festo.com/en/engineering)

## Dovetail mounting

HMSV-1

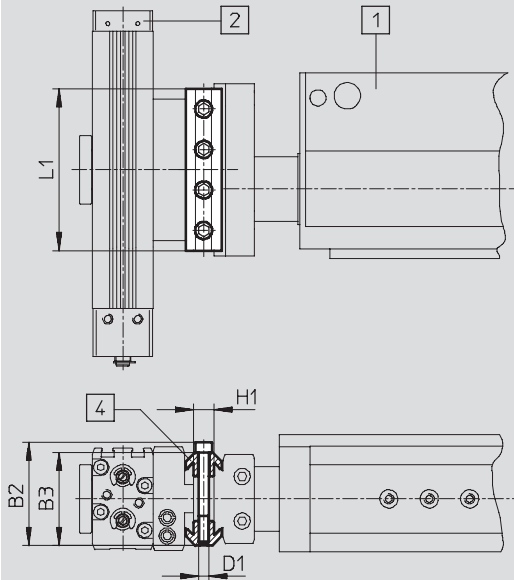

- 1 Linear module HMP, HME<sup>2)</sup>
- 2 Semi-rotary drive DRQD-SD
- 4 Dovetail clamp

HMSV-10/14/16/18/19

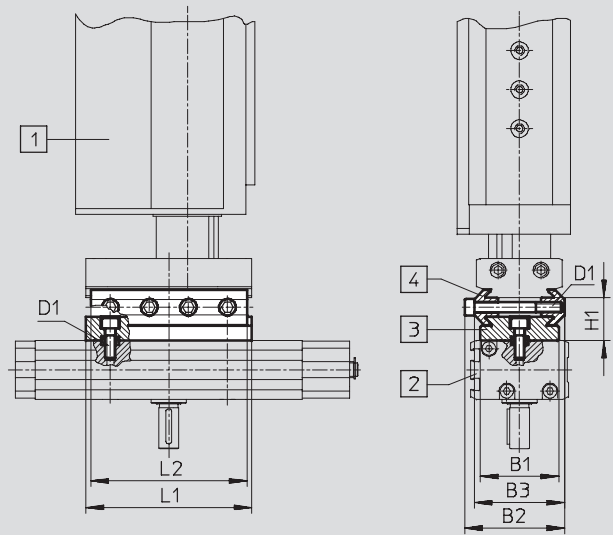

- 1 Linear module HMP, HME<sup>2)</sup>
  - 2 Semi-rotary drive DRQD
- Adapter kit HMSV, comprising:
- 3 Adapter plate
  - 4 Dovetail clamp

Drive	Drive	B1	B2	B3	D1	H1	L1	L2	CRC <sup>1)</sup>	Part No.	Type
HMP-16/20/25/32 HME-16 <sup>2)</sup>	DRQD-16/20 (SD32, SD42)	-	51	46	M5	10	80	-	2	177 647	HMSV-1
HMP-16/20/25 HME-16/25 <sup>2)</sup>	DRQD-16/20	40	51	46	M5	22	85	80	2	177 656	HMSV-10
HMP/HME-25 <sup>2)</sup>	DRQD-25	50				24	110	100		177 660	HMSV-14
HMP-32	DRQD-20					133	120	177 662		HMSV-16	
	DRQD-25					177 664	HMSV-18				
	DRQD-32									177 665	HMSV-19

1) Corrosion resistance class 2 to Festo standard 940 070  
Components subject to moderate corrosion stress. Externally visible parts with primarily decorative surface requirements which are in direct contact with a normal industrial environment or media such as coolants or lubricating agents

2) HME: Horizontal mounting position, vertical on request

# HMP, HME/DSL combination

Technical data



## Adapter kit HMSV

Material:  
Wrought aluminium alloy, anodised  
Slot nuts: Tempered steel  
Free of copper, PTFE and silicone

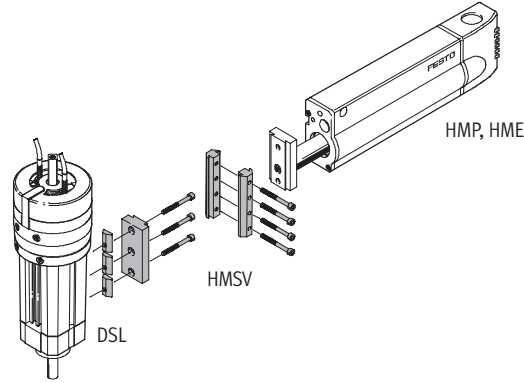

Dovetail mounting

## Dimensions and ordering data

Download CAD data → [www.festo.com/en/engineering](http://www.festo.com/en/engineering)

### Dovetail mounting

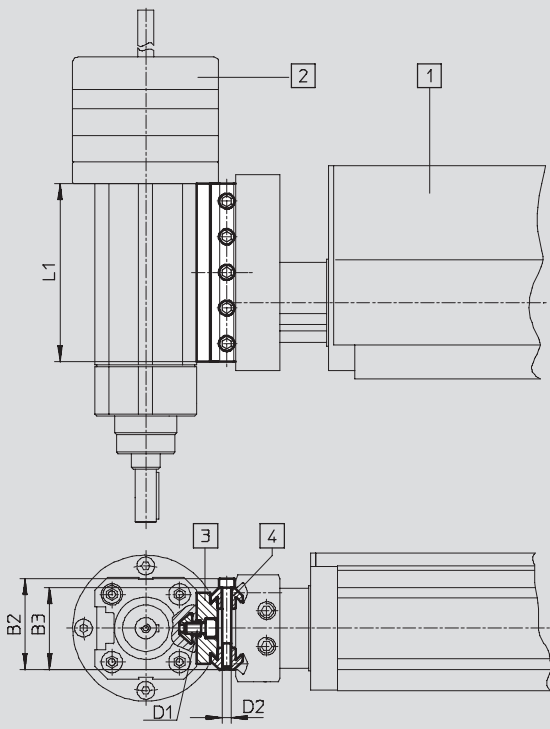

- 1 Linear module HMP, HME
  - 2 Swivel/linear unit DSL
- Adapter kit HMSV, comprising:
- 3 Adapter plate
  - 4 Dovetail clamp

Drive	Drive	B2	B3	D1	D2	L1	CRC <sup>1)</sup>	Part No.	Type
HMP-16/20/25	DSL-16	51	46	M5	M5	80	2	177 654	HMSV-8
HME-16/25	DSL-20								
HMP-20/25	DSL-25								
HME-25	DSL-25	51	46	M6	M5	100	2	177 655	HMSV-9
HMP/HME-25	DSL-25								
HMP-32	DSL-20/25/32								

1) Corrosion resistance class 2 to Festo standard 940 070

Components subject to moderate corrosion stress. Externally visible parts with primarily decorative surface requirements which are in direct contact with a normal industrial environment or media such as coolants or lubricating agents

# HMPL/HMPL combination

Technical data

## Adapter kit

(user configured)

Material:  
to DIN 912  
Centring sleeves: High-alloy steel  
Free of copper, PTFE and silicone

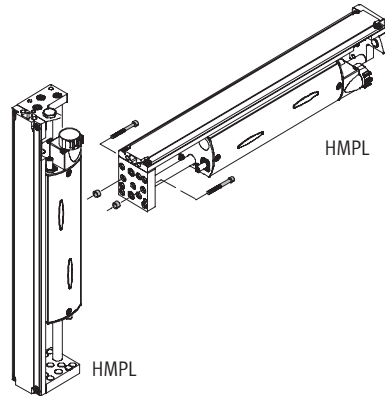

Direct mounting

## Dimensions and ordering data

Download CAD data → [www.festo.com/en/engineering](http://www.festo.com/en/engineering)

Direct mounting

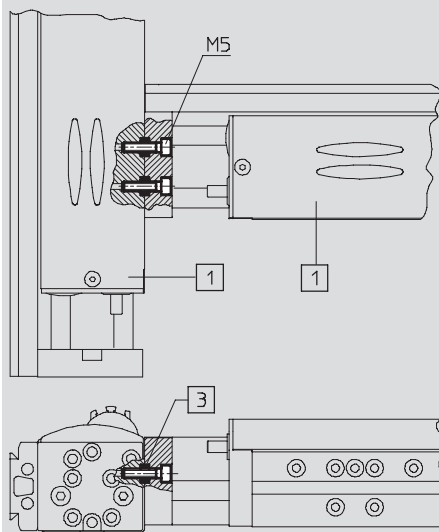

- 1 Linear module HMPL
- 3 Centring sleeve ZBH-9

Drive	Drive	Part No.	Type	Required quantity	PU <sup>2)</sup>
HMPL-12	HMPL-12	-	M5x16 DIN 912 <sup>1)</sup>	2	-
HMPL-16	HMPL-12/16	150 927	ZBH-9	2	10
HMPL-20	HMPL-12/16/20				

1) The screws listed are not included with the drives  
2) Packaging unit quantity

# HMPL/DRQD combination

Technical data



## Adapter kit HAPG

Material:  
Wrought aluminium alloy, anodised  
Centring sleeves: High-alloy steel  
Free of copper, PTFE and silicone

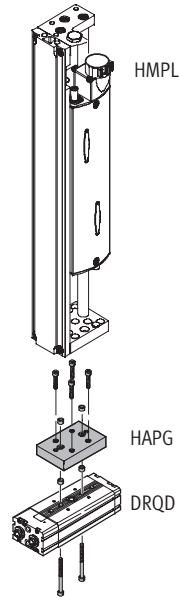

Direct mounting

## Dimensions and ordering data

Download CAD data → [www.festo.com/en/engineering](http://www.festo.com/en/engineering)

### Direct mounting

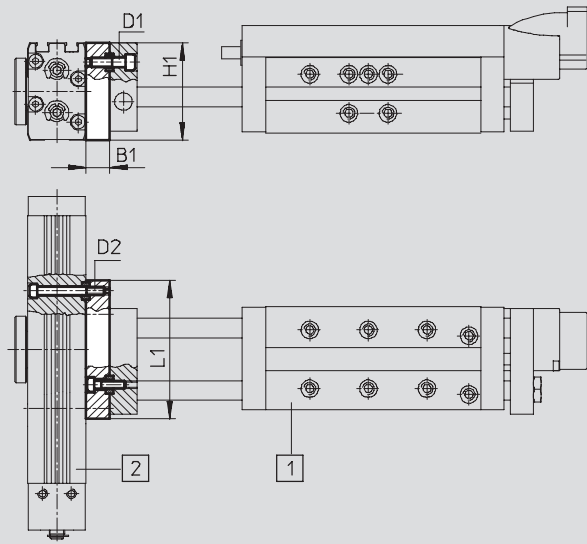

- 1 Linear module HMPL
- 2 Semi-rotary drive DRQD

Drive	Drive <sup>1)</sup>	B1	D1	D2	H1	L1	CRC <sup>2)</sup>	Part No.	Type	Required quantity
HMPL-12	DRQD-6	-	-	-	-	-	-	-	M4x16 DIN 912 <sup>3)</sup>	2
HMPL-16/20	DRQD-8/12	-	-	-	-	-	-	-	M5x20 DIN 912 <sup>3)</sup>	2
	DRQD-6	12	M5	M4	42	50	2	193 920	HAPG-36-S2	1
	50				71	192 707		HAPG-38	1	

- 1) When using DRQD-8 and 12 with flanged shaft with air throughfeed SD32, the mounting type DRQD-...-B2 must be chosen
- 2) Corrosion resistance class 2 to Festo standard 940 070  
Components subject to moderate corrosion stress. Externally visible parts with primarily decorative surface requirements which are in direct contact with a normal industrial environment or media such as coolants or lubricating agents
- 3) The screws listed are not included with the drives



# DGSL/DGSL combination

Technical data

## Adapter kit

Material:

Centring sleeves and connecting sleeves: High-alloy steel

Free of copper, PTFE and silicone

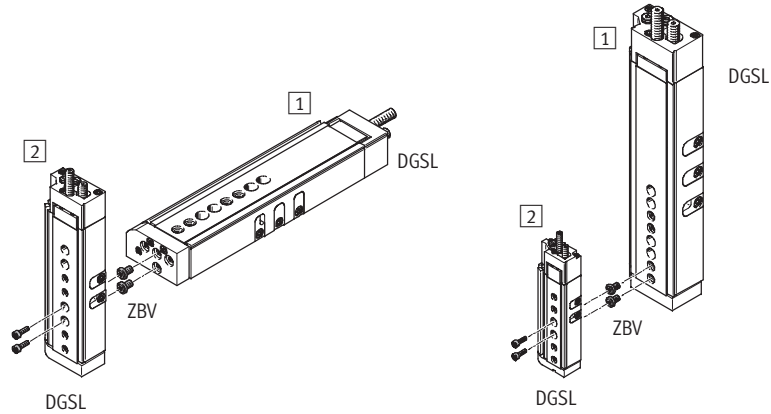

Direct mounting

Direct mounting

Ordering data		Download CAD data → <a href="http://www.festo.com/en/engineering">www.festo.com/en/engineering</a>				
Drive 1	Drive 2	CRC <sup>1)</sup>	Part No.	Type	Required quantity	PU <sup>4)</sup>
DGSL-4	DGSL-4	2	–	M3x7 <sup>2)</sup>	2	–
			189 652	ZBH-5 <sup>3)</sup>	2	10
DGSL-6	DGSL-4/-6		–	M3x10 <sup>2)</sup>	2	–
			189 652	ZBH-5 <sup>3)</sup>	2	10
DGSL-8/-10	DGSL-4/-6		548 802	ZBV-M4-7	1	3
DGSL-8/-10	DGSL-8		–	M4x12 <sup>2)</sup>	2	–
			186 717	ZBH-7 <sup>3)</sup>	2	10
DGSL-10	DGSL-10		–	M4x14 <sup>2)</sup>	3	–
			186 717	ZBH-7 <sup>3)</sup>	3	10
DGSL-12/-16	DGSL-8/-10		548 803	ZBV-M5-7	1	3
DGSL-12	DGSL-12		–	M5x14 <sup>2)</sup>	3	–
			186 717	ZBH-7 <sup>3)</sup>	3	10
DGSL-16	DGSL-12		–	M5x16 <sup>2)</sup>	3	–
			186 717	ZBH-7 <sup>3)</sup>	3	10
DGSL-16	DGSL-16		–	M5x18 <sup>2)</sup>	3	–
			186 717	ZBH-7 <sup>3)</sup>	3	10
DGSL-20/-25	DGSL-12/-16	548 804	ZBV-M5-9	1	3	
DGSL-20/-25	DGSL-20	–	M6x20 <sup>2)</sup>	3	–	
		150 927	ZBH-9 <sup>3)</sup>	3	10	
DGSL-25	DGSL-25	–	M6x30 <sup>2)</sup>	3	–	
		150 927	ZBH-9 <sup>3)</sup>	3	10	

1) Corrosion resistance class 2 to Festo standard 940 070  
 Components subject to moderate corrosion stress. Externally visible parts with primarily decorative surface requirements which are in direct contact with a normal industrial environment or media such as coolants or lubricating agents

2) The screws listed are not included with the drives

3) The centring sleeves are supplied together with the drives

4) Packaging unit quantity

# DGSL/DRQD combination

Technical data



## Adapter kit HMSV

Material:  
Wrought aluminium alloy, anodised  
Centring sleeves: High-alloy steel  
Free of copper, PTFE and silicone

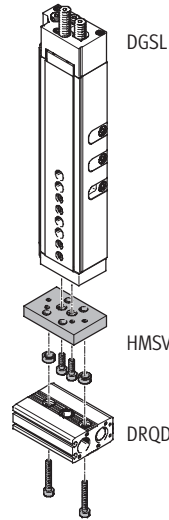

Direct mounting on yoke plate

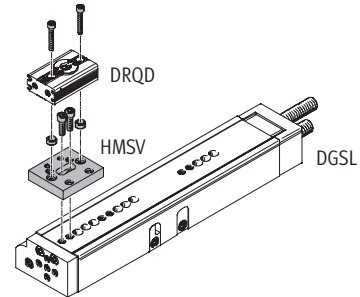

Direct mounting on slide

## Dimensions and ordering data

Download CAD data → [www.festo.com/en/engineering](http://www.festo.com/en/engineering)

Direct mounting

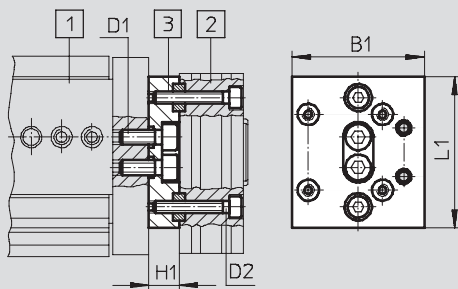

- 1 Mini slide DGSL
- 2 Semi-rotary drive DRQD
- 3 Adapter plate HMSV

Drive	Drive	B1	D1	D2	H1	L1	CRC <sup>1)</sup>	Part No.	Type
<b>Direct mounting on yoke plate</b>									
DGSL-4/6	DRQD-6	17	M3	M3	8	40	2	548 783	HMSV-53
DGSL-8/10	DRQD-8/12	33	M4	M3	9	50	2	548 784	HMSV-54
DGSL-12/16	DRQD-8/12	43.5	M6	M4	10			548 785	HMSV-55
DGSL-20/25	DRQD-16/20	73			12	100	548 786	HMSV-56	
<b>Direct mounting on slide</b>									
DGSL-8/10	DRQD-8/12	33	M4	M3	9	50	2	548 784	HMSV-54
DGSL-12/16	DRQD-8/12	43.5	M6	M4	10			548 785	HMSV-55
DGSL-20/25	DRQD-16/20	73			12	100	548 786	HMSV-56	

1) Corrosion resistance class 2 to Festo standard 940 070

Components subject to moderate corrosion stress. Externally visible parts with primarily decorative surface requirements which are in direct contact with a normal industrial environment or media such as coolants or lubricating agents

# SLT, SLTE/SLT, SLTE combination

Technical data



## Adapter kit

(user configured)

Material:  
to DIN 912  
Centring sleeves: High-alloy steel  
Free of copper, PTFE and silicone

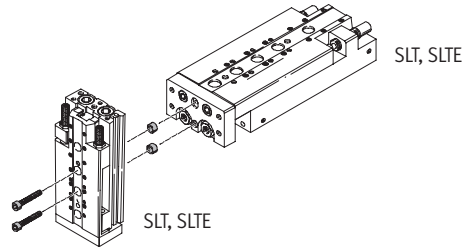

Direct mounting on yoke plate

## Dimensions and ordering data

Download CAD data → [www.festo.com/en/engineering](http://www.festo.com/en/engineering)

Direct mounting

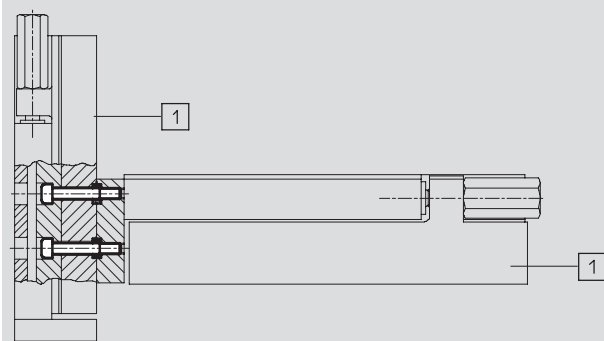

1 Mini slide SLT, SLTE

Drive	Drive	Part No.	Type	Required quantity	PU <sup>2)</sup>
SLT/SLTE-10	SLT-6	–	M3x20 DIN 912 <sup>1)</sup>	2	–
		189 652	ZBH-5	2	10
SLT/SLTE-16	SLT/SLTE-10	–	M4x25 DIN 912 <sup>1)</sup>	2	–
		186 717	ZBH-7	2	10
SLT-20	SLT/SLTE-16	–	M5x30 DIN 912 <sup>1)</sup>	2	–
		150 927	ZBH-9	2	10
SLT-25	SLT-20	–	M6x40 DIN 912 <sup>1)</sup>	2	–
		189 653	ZBH-12	2	10

1) The screws listed are not included with the drives

2) Packaging unit quantity

# SLT, SLTE/DRQD combination

Technical data



## Adapter kit HAPS

Material:  
Wrought aluminium alloy, anodised  
Centring sleeves: High-alloy steel  
Free of copper, PTFE and silicone

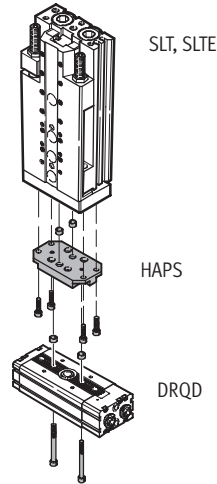

Direct mounting

## Dimensions and ordering data

Download CAD data → [www.festo.com/en/engineering](http://www.festo.com/en/engineering)

Direct mounting

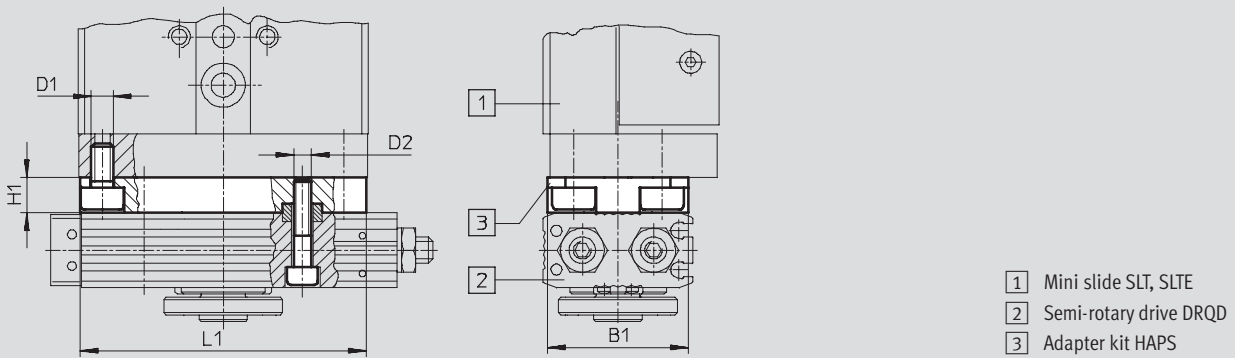

- 1 Mini slide SLT, SLTE
- 2 Semi-rotary drive DRQD
- 3 Adapter kit HAPS

Drive	Drive	B1	D1	D2	H1	L1	CRC <sup>1)</sup>	Part No.	Type
SLT-6	DRQD-6	16	M3	M4	8	36	2	178 447	HAPS-1
SLT/SLTE-10	DRQD-8	28	M4			48		178 448	HAPS-2
SLT/SLTE-16	DRQD-12	32	M5			65		178 449	HAPS-3
SLT-20	DRQD-16/20	44		M5	80	178 450		HAPS-4	
SLT-25	DRQD-16/20	58	M8	M6	12	91		178 451	HAPS-5

1) Corrosion resistance class 2 to Festo standard 940 070

Components subject to moderate corrosion stress. Externally visible parts with primarily decorative surface requirements which are in direct contact with a normal industrial environment or media such as coolants or lubricating agents

# SLG/DGSL combination

Technical data

## Adapter kit HAPS

Material:  
Wrought aluminium alloy, anodised  
Centring sleeves: High-alloy steel  
Free of copper, PTFE and silicone

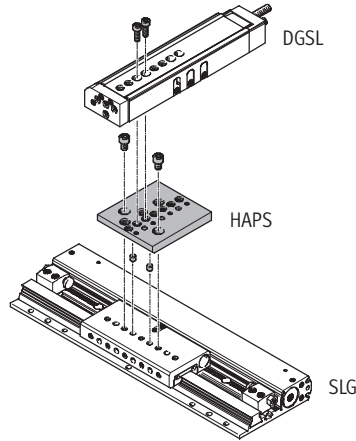

Direct mounting

## Dimensions and ordering data

Download CAD data → [www.festo.com/en/engineering](http://www.festo.com/en/engineering)

Direct mounting

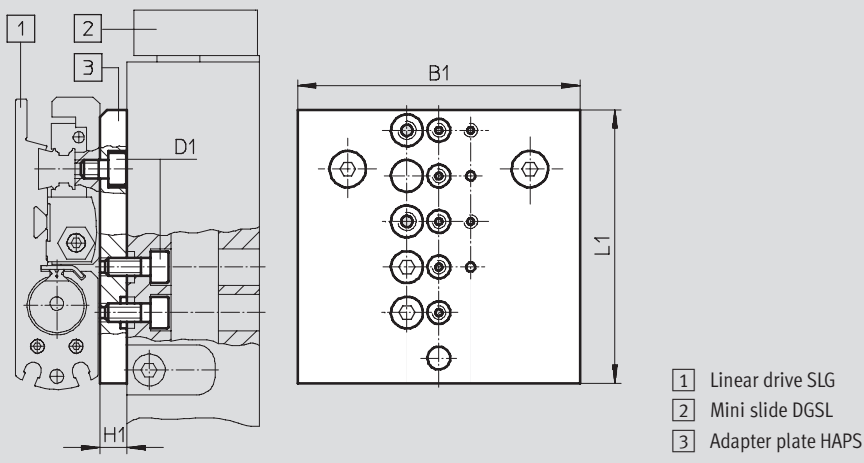

- 1 Linear drive SLG
- 2 Mini slide DGSL
- 3 Adapter plate HAPS

Drive	Drive	B1	D1	H1	L1	CRC <sup>1)</sup>	Part No.	Type
SLG-8	DGSL-4/6	62	M4	6	60	2	189 533	HAPS-11
SLG-12	DGSL-4/6/8/10							
SLG-18	DGSL-8/10/12	65	M5	8	80		189 534	HAPS-12

1) Corrosion resistance class 2 to Festo standard 940 070  
Components subject to moderate corrosion stress. Externally visible parts with primarily decorative surface requirements which are in direct contact with a normal industrial environment or media such as coolants or lubricating agents

# SLG/SLT, SLTE combination

Technical data



## Adapter kit HAPS

Material:  
Wrought aluminium alloy, anodised  
Centring sleeves: High-alloy steel  
Free of copper, PTFE and silicone

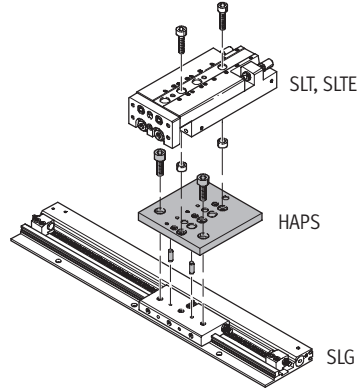

Direct mounting

## Dimensions and ordering data

Download CAD data → [www.festo.com/en/engineering](http://www.festo.com/en/engineering)

Direct mounting

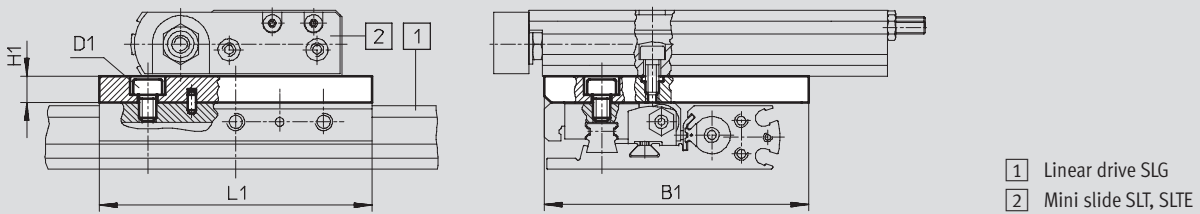

Drive	Drive	B1	D1	H1	L1	CRC <sup>1)</sup>	Part No.	Type
SLG-8	SLT-6	60	M4	6	42	2	189 533	HAPS-11
SLG-12	SLT-6/10 SLTE-10							
SLG-18	SLT/SLTE-10/16	70	M5	8	65		189 534	HAPS-12

1) Corrosion resistance class 2 to Festo standard 940 070  
Components subject to moderate corrosion stress. Externally visible parts with primarily decorative surface requirements which are in direct contact with a normal industrial environment or media such as coolants or lubricating agents

# SLG/SLF combination

Technical data

## Adapter kit HAPS

Material:  
 Wrought aluminium alloy, anodised  
 Centring sleeves: High-alloy steel  
 Free of copper, PTFE and silicone

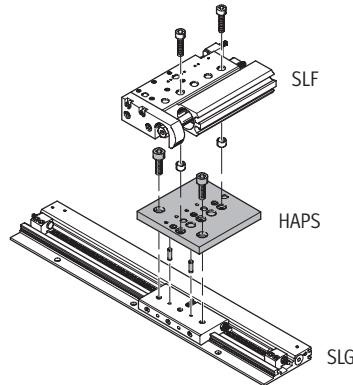

Direct mounting

## Dimensions and ordering data

Download CAD data → [www.festo.com/en/engineering](http://www.festo.com/en/engineering)

Direct mounting

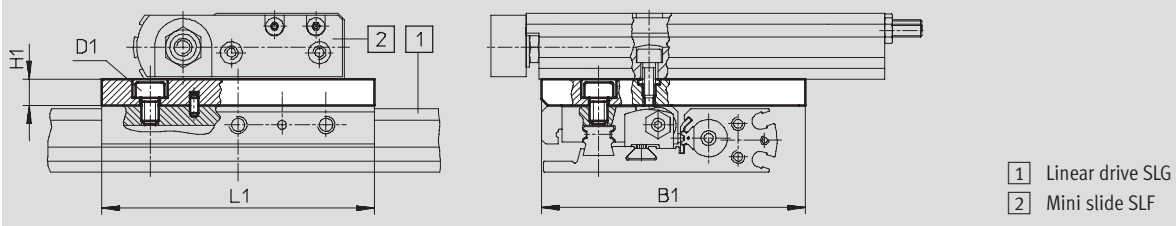

- 1 Linear drive SLG
- 2 Mini slide SLF

Drive	Drive	B1	D1	H1	L1	CRC <sup>1)</sup>	Part No.	Type
SLG-8/12	SLF-6/10	60	M4	6	42	2	189 533	HAPS-11
SLG-12	SLF-16							
SLG-18	SLF-10/16	70	M5	8	65		189 534	HAPS-12

1) Corrosion resistance class 2 to Festo standard 940 070  
 Components subject to moderate corrosion stress. Externally visible parts with primarily decorative surface requirements which are in direct contact with a normal industrial environment or media such as coolants or lubricating agents

# DRQD/HMP, HME, HMPL, SLT, SLTE combination

Technical data



## Adapter kit HMAV, HMSV

Material:  
Wrought aluminium alloy, anodised  
Centring sleeves: High-alloy steel  
Free of copper, PTFE and silicone

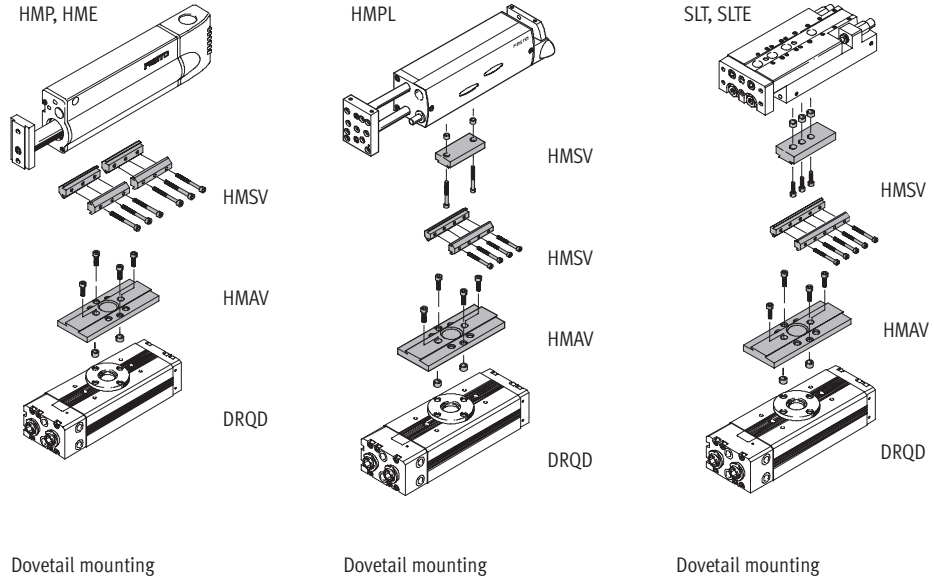

Dovetail mounting

Dovetail mounting

Dovetail mounting

## Dimensions and ordering data

Download CAD data → [www.festo.com/en/engineering](http://www.festo.com/en/engineering)

Dovetail mounting DRQD/HMP, HME

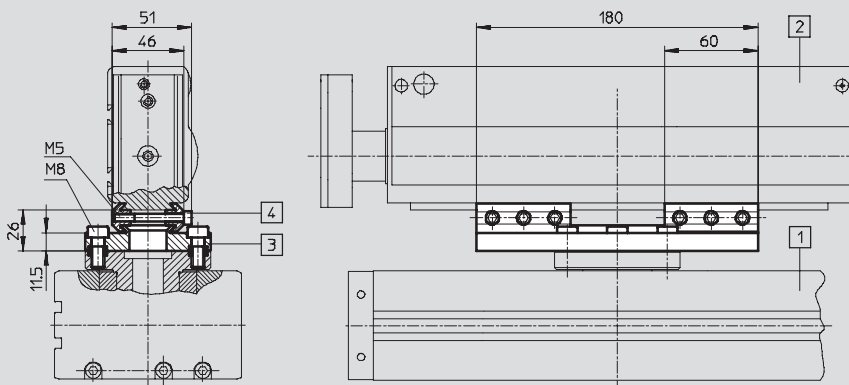

- 1 Semi-rotary drive DRQD
- 2 Linear module HMP, HME
- 3 Adapter kit HMAV-DRQD40/50
- 4 Adapter kit HMSV-7

Drive	Drive	CRC <sup>1)</sup>	Part No.	Type
DRQD-40/50	HMP-16/20	2	533 804	HMAV-DRQD40/50
	HME-16		177 653	HMSV-7

1) Corrosion resistance class 2 to Festo standard 940 070

Components subject to moderate corrosion stress. Externally visible parts with primarily decorative surface requirements which are in direct contact with a normal industrial environment or media such as coolants or lubricating agents



# DRQD/HMP, HME, HMPL, SLT, SLTE combination

Technical data



Dimensions and ordering data Download CAD data → [www.festo.com/en/engineering](http://www.festo.com/en/engineering)

## Dovetail mounting DRQD/HMPL

- 1 Semi-rotary drive DRQD
- 2 Linear module HMPL
- 3 Adapter kit HMAV-DRQD40/50
- 4 Adapter kit HMSV-1
- 5 Adapter kit HMSV-86

Drive	Drive	CRC <sup>1)</sup>	Part No.	Type
DRQD-40/50	HMPL-12/16/20	2	533 804	HMAV-DRQD40/50
			193 923	HMSV-46
			177 647	HMSV-1

1) Corrosion resistance class 2 to Festo standard 940 070  
 Components subject to moderate corrosion stress. Externally visible parts with primarily decorative surface requirements which are in direct contact with a normal industrial environment or media such as coolants or lubricating agents.

## Dovetail mounting DRQD/SLT, SLTE

- 1 Semi-rotary drive DRQD
- 2 Mini slide SLT, SLTE
- 3 Adapter kit HMAV-DRQD40/50
- 4 Adapter kit HMSV-36 or HMSV-37

Drive	Drive	D1	H1	CRC <sup>1)</sup>	Part No.	Type
DRQD-40	SLT/SLTE-16	–	–	2	533 804	HMAV-DRQD40/50
		M6	40		178 331	HMSV-36
DRQD-40/50	SLT-20/25	–	–		533 804	HMAV-DRQD40/50
		M8	42		178 332	HMSV-37

1) Corrosion resistance class 2 to Festo standard 940 070  
 Components subject to moderate corrosion stress. Externally visible parts with primarily decorative surface requirements which are in direct contact with a normal industrial environment or media such as coolants or lubricating agents

# DG.../HMP, HME combination

Technical data



## Adapter kit HMAV-DL

Material:

Wrought aluminium alloy, anodised

Centring sleeves: High-alloy steel

Slot nuts: Tempered steel

Free of copper, PTFE and silicone

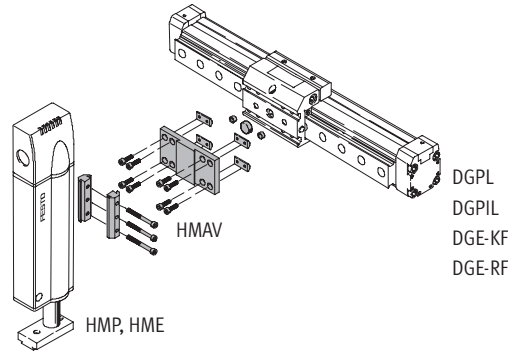

Dovetail mounting

## Dimensions and ordering data

Download CAD data → [www.festo.com/en/engineering](http://www.festo.com/en/engineering)

Dovetail mounting

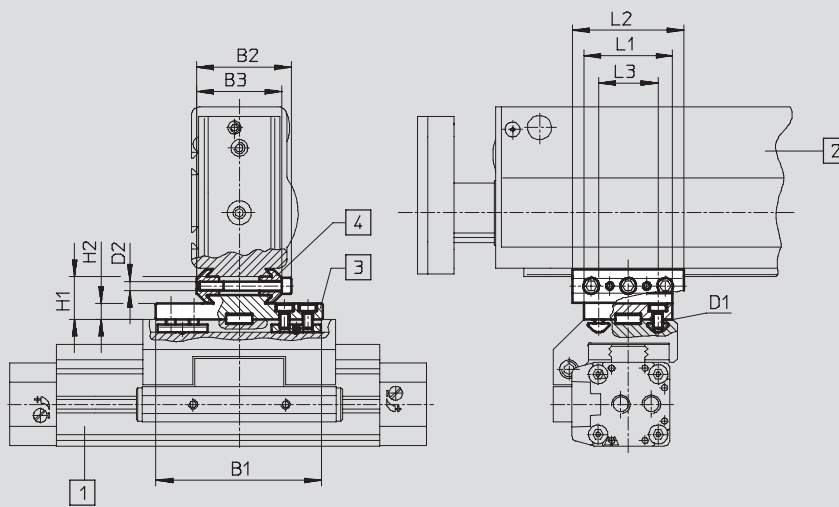

- 1 Linear drives  
DGPL/DGPIL/DGE-KF/DGE-RF
  - 2 Linear module HMP, HME<sup>2)</sup>
- Adapter kit HMAV-DL, comprising:
- 3 Adapter plate
  - 4 Dovetail clamp

Drive	Drive	B1	B2	B3	D1	D2	H1	H2	L1	L2	L3	CRC <sup>1)</sup>	Part No.	Type
DG...-25	HMP-16/20 HME-16 <sup>2)</sup>	90	51	46	M5	M5	23	8.5	48	60	32	2	176 005	HMAV-DL25
DG...-32	HMP-16/20/25 HME-16/25 <sup>2)</sup>								63.5		47		176 006	HMAV-DL32
DG...-40	HMP-20/25/32 HME-16/25 <sup>2)</sup>								78	55	176 007		HMAV-DL40	
DG...-50	HMP-20/25/32 HME-16/25 <sup>2)</sup>	80	M8	M5	26	11.5	98	120	72	176 008	HMAV-DL50			
DG...-63	HMP-20/25/32 HME-16/25 <sup>2)</sup>						120		90	176 009	HMAV-DL63			

1) Corrosion resistance class 2 to Festo standard 940 070

Components subject to moderate corrosion stress. Externally visible parts with primarily decorative surface requirements which are in direct contact with a normal industrial environment or media such as coolants or lubricating agents

2) HME: Horizontal mounting position, vertical on request

# DG.../HMPL combination

Technical data

## Adapter kit HMAV, HMSV

Material:  
 Wrought aluminium alloy, anodised  
 Centring sleeves: High-alloy steel  
 Slot nuts: Tempered steel  
 Free of copper, PTFE and silicone

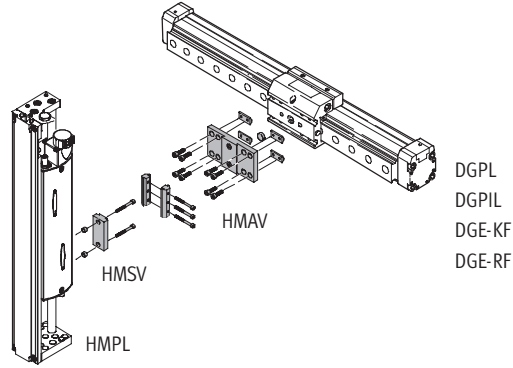

Dovetail mounting

## Dimensions and ordering data

Download CAD data → [www.festo.com/en/engineering](http://www.festo.com/en/engineering)

Dovetail mounting

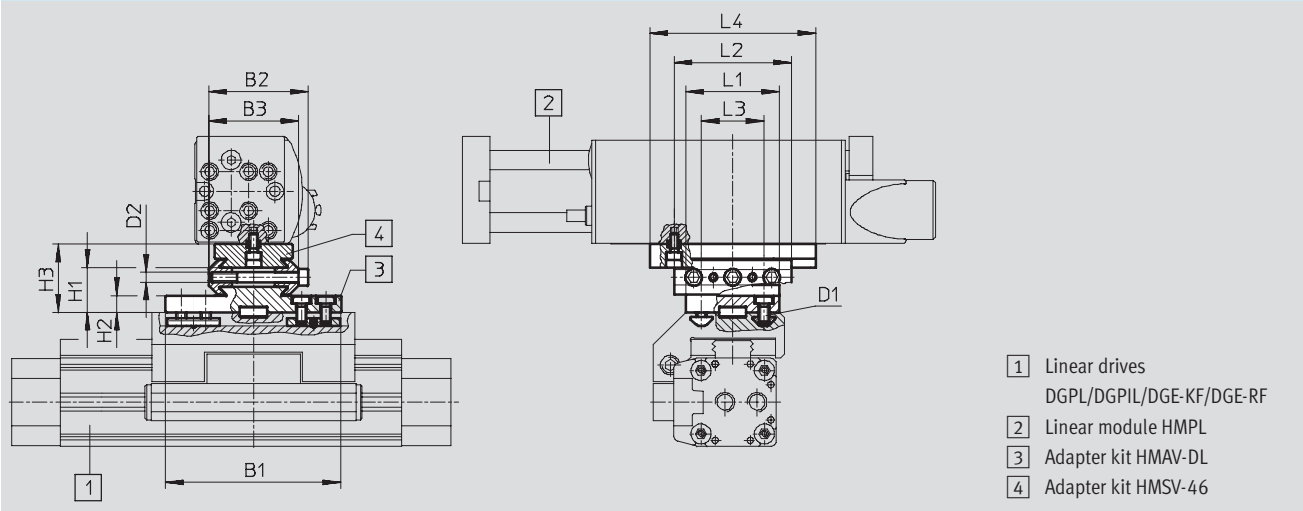

Drive	Drive	B1	B2	B3	D1	D2	H1	H2	H3	L1	L2	L3	L4	CRC <sup>1)</sup>	Part No.	Type
DG...-25	HMPL-12/16/20	90	51	46	M5	M5	23	8.5	35	48	60	47	85	2	176 005	HMAV-DL25
										193 923					HMSV-46	
DG...-32	HMPL-16/20									63.5	176 006	HMAV-DL32				
			193 923	HMSV-46												
DG...-40	HMPL-20									78	64	55			176 007	HMAV-DL40
															193 923	HMSV-46

1) Corrosion resistance class 2 to Festo standard 940 070  
 Components subject to moderate corrosion stress. Externally visible parts with primarily decorative surface requirements which are in direct contact with a normal industrial environment or media such as coolants or lubricating agents

# DG.../DGSL combination

Technical data



## Adapter kit HMSV

Material:

Wrought aluminium alloy, anodised

Centring sleeves: High-alloy steel

Free of copper, PTFE and silicone

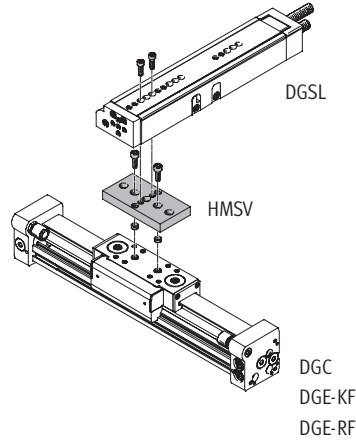

Direct mounting

## Dimensions and ordering data

Download CAD data → [www.festo.com/en/engineering](http://www.festo.com/en/engineering)

Direct mounting

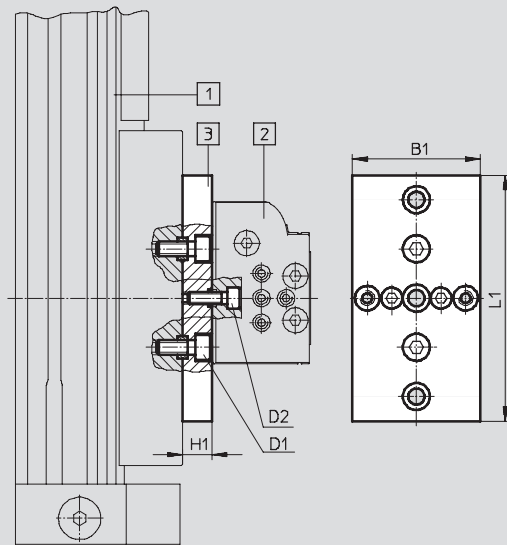

- 1 Linear drives  
DGC/DGE-KF/DGE-RF
- 2 Mini slide DGSL
- 3 Adapter kit HMSV

Drive	Drive	B1	D1	D2	H1	L1	CRC <sup>1)</sup>	Part No.	Type
DGC-8/12	DGSL-4/6	25	M4	M3	6	52	2	548 777	HMSV-47
DGC-18	DGSL-8/10	34,5	M5	M4	8			548 778	HMSV-48
DG...-25	DGSL-12/16/20/25	52	M6	M5	12	548 781		HMSV-51	
DGC-32/40 DGE-40-KF DGE-40-RF	DGSL-20/25	60		M6	13	100		548 780	HMSV-50

1) Corrosion resistance class 2 to Festo standard 940 070  
Components subject to moderate corrosion stress. Externally visible parts with primarily decorative surface requirements which are in direct contact with a normal industrial environment or media such as coolants or lubricating agents

# DG.../SLT, SLTE combination

Technical data

## Adapter kit HMSV

Material:  
 Wrought aluminium alloy, anodised  
 Centring sleeves: High-alloy steel  
 Slot nuts: Tempered steel  
 Free of copper, PTFE and silicone

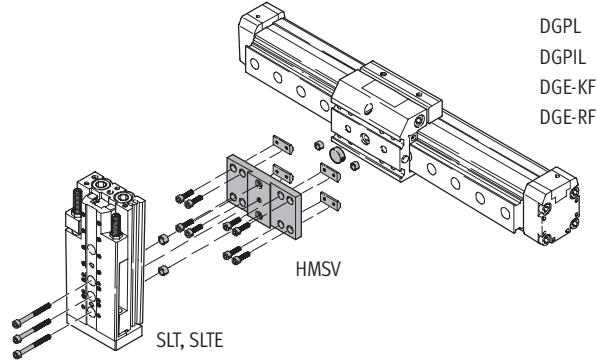

Dovetail mounting

## Dimensions and ordering data

Download CAD data → [www.festo.com/en/engineering](http://www.festo.com/en/engineering)

Dovetail mounting

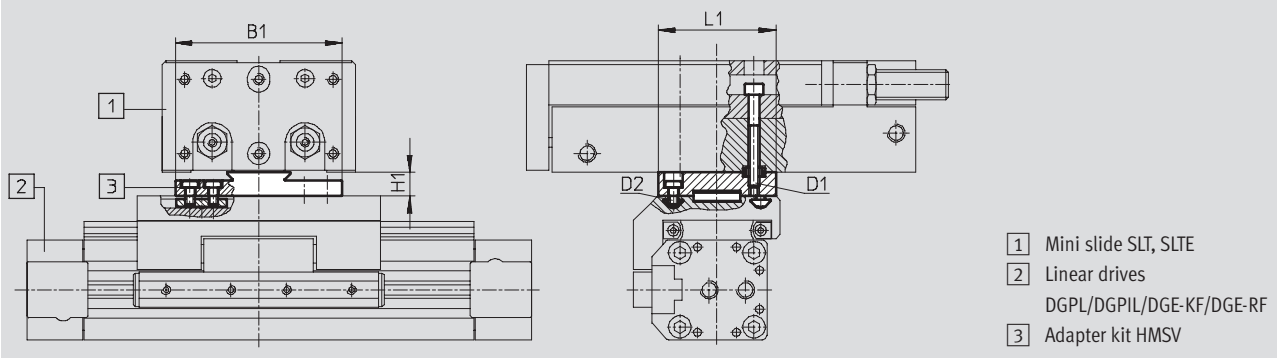

Drive	Drive	B1	D1	D2	H1	L1	CRC <sup>1)</sup>	Part No.	Type
DG...-18	SLT/SLTE-10	80	M4	M5	12	40	2	189 656	HMSV-40
	SLT/SLTE-16		M5					189 657	HMSV-41
DG...-25	SLT/SLTE-16	90	M6	M5	13	54	2	189 658	HMSV-42
	SLT-20					63.5		189 659	HMSV-43
DG...-32	SLT-20	90	M6	M5	13	63.5	2	189 660	HMSV-44
	SLT-25							189 661	HMSV-45

1) Corrosion resistance class 2 to Festo standard 940 070  
 Components subject to moderate corrosion stress. Externally visible parts with primarily decorative surface requirements which are in direct contact with a normal industrial environment or media such as coolants or lubricating agents

# DG.../DRQD combination

Technical data



## Adapter kit HMAV, HMSV

Material:  
Wrought aluminium alloy, anodised  
Centring sleeves: High-alloy steel  
Free of copper, PTFE and silicone

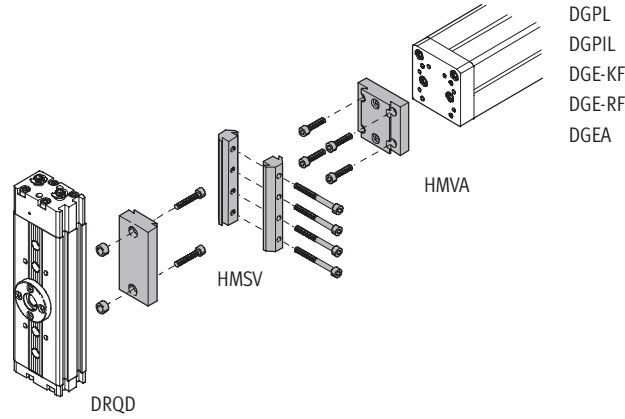

DGPL  
DGPIL  
DGE-KF  
DGE-RF  
DGEA

Dovetail mounting

## Dimensions

Download CAD data → [www.festo.com/en/engineering](http://www.festo.com/en/engineering)

Dovetail mounting

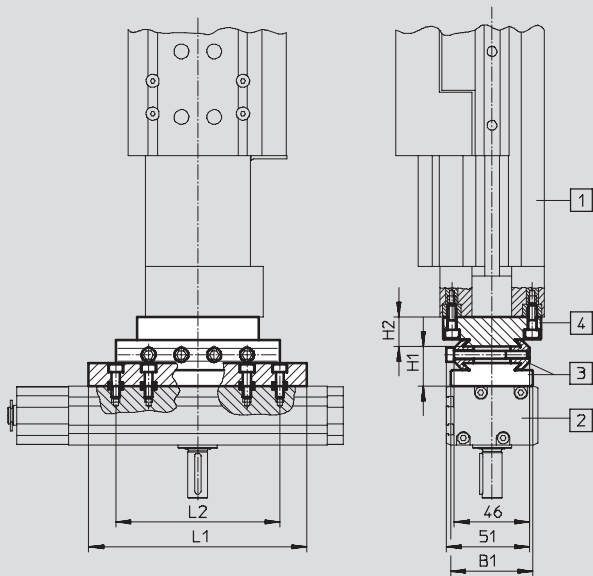

- 1 Linear drives  
DGPL/DGPIL/DGE-KF/DGE-RF/  
DGEA
- 2 Semi-rotary drive DRQD
- 3 Adapter kit HMSV
- 4 Adapter kit HMAV

# DG.../DRQD combination

Technical data

Dimensions and ordering data									
Drive	Drive	B1	H1	H2	L1	L2	CRC <sup>1)</sup>	Part No.	Type
Dovetail mounting									
DRQD-16/20	DGEA-18	40	22	14	85	80	2	196 788	HMVA-DLA18/25
	DG...-25/32/40							177 656	HMSV-10
DRQD-20	DG...-32	40	22	18	85	80		196 789	HMVA-DL32
	DG...-40							177 656	HMSV-10
DRQD-25	DGEA-18	50	24	18	110	100		196 790	HMVA-DLA40
	DG...-25							177 660	HMSV-14
	DG...-32							196 789	HMVA-DL32
DRQD-32	DG...-40	50	24	18	110	100		177 660	HMSV-14
	DG...-32							196 789	HMVA-DL32
	DG...-40							177 665	HMSV-19
DRQD-32	DG...-32	50	24	18	133	120	196 790	HMVA-DLA40	
	DG...-40						177 665	HMSV-19	

1) Corrosion resistance class 2 to Festo standard 940 070  
 Components subject to moderate corrosion stress. Externally visible parts with primarily decorative surface requirements which are in direct contact with a normal industrial environment or media such as coolants or lubricating agents

# DG.../DG... combination

Technical data



## Cross connecting kit HMVK

Material:  
Wrought aluminium alloy, anodised  
Centring sleeves: High-alloy steel  
Slot nuts: Tempered steel  
Free of copper, PTFE and silicone

Slide/slide mounting

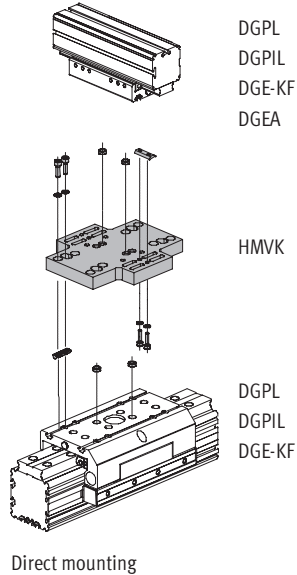

Slide/profile mounting

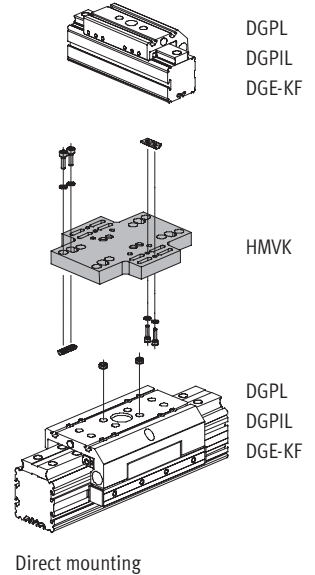

## Dimensions and ordering data

Download CAD data → [www.festo.com/en/engineering](http://www.festo.com/en/engineering)

### Direct mounting

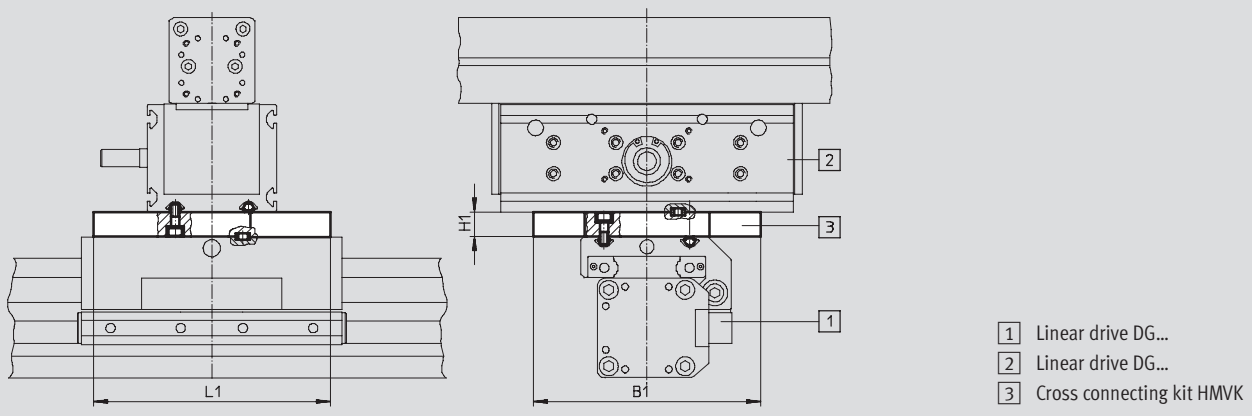

Drive 1	Drive 2	B1	H1	L1	CRC <sup>1)</sup>	Part No.	Type
<b>Direct slide/slide mounting</b>							
DG...-25	DG...-18/25	105	12	105	2	196 779	HMVK-DL25-DL18/25
DG...-32	DG...-25	146	16	152		196 781	HMVK-DL32/40-DLA18-32
DG...-40	DG...-25/32					196 783	HMVK-DL63-DLA25/40
DG...-40	DGEA-18/25						
DG...-63	DG...-40	192	23	230			
DG...-63	DGEA-25/40						
<b>Direct slide/profile mounting</b>							
DG...-18	DG...-18	105	12	105	2	196 780	HMVK-DL18/25-DL-18/25
DG...-25	DG...-25	192	23	230	2	196 782	HMVK-DL32/40-DL25
DG...-32/40	DG...-25						
DG...-40	DG...-32/40						

1) Corrosion resistance class 2 to Festo standard 940 070

Components subject to moderate corrosion stress. Externally visible parts with primarily decorative surface requirements which are in direct contact with a normal industrial environment or media such as coolants or lubricating agents



# DG.../DFM combination

Technical data

## Adapter kit HAPB

Material:  
Wrought aluminium alloy, anodised  
Slot nuts: Tempered steel  
Free of copper, PTFE and silicone

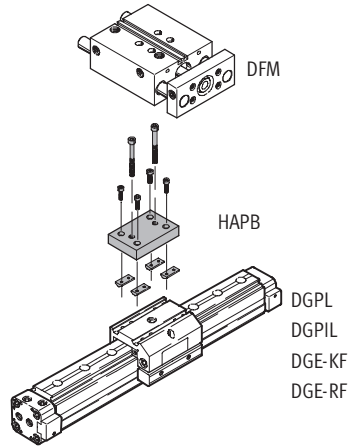

Direct mounting

## Dimensions and ordering data

Download CAD data → [www.festo.com/en/engineering](http://www.festo.com/en/engineering)

Direct mounting

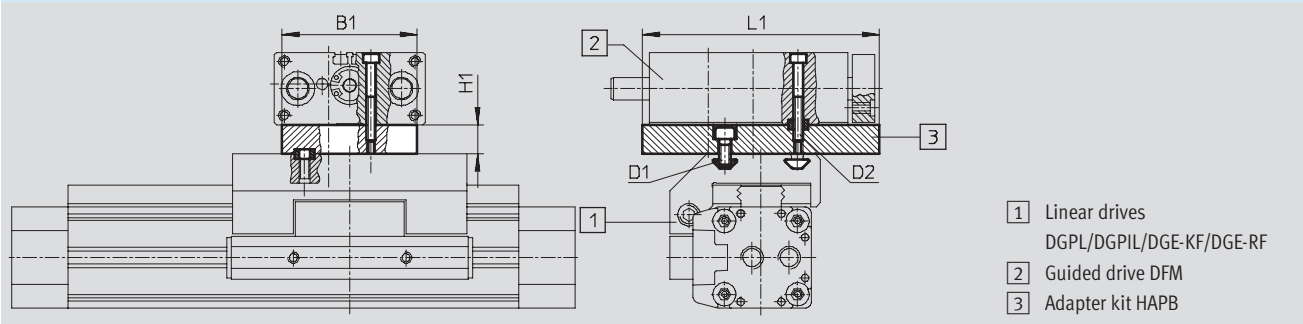

Drive	Drive	B1	D1	D2	H1	L1	CRC <sup>1)</sup>	Part No.	Type
DG...-25	DFM-12/16	60	M5	M4	13	105	2	192 690	HAPB-12/16
DG...-32	DFM-20/25	83		M5		115		192 691	HAPB-20/25
DG...-40	DFM-32/40	110		M6	132	192 692		HAPB-32/40	

1) Corrosion resistance class 2 to Festo standard 940 070  
Components subject to moderate corrosion stress. Externally visible parts with primarily decorative surface requirements which are in direct contact with a normal industrial environment or media such as coolants or lubricating agents

# DG.../DPZ combination

Technical data



## Adapter kit HAPB, connecting kit HAVB

Material:

Wrought aluminium alloy, anodised

Centring sleeves: High-alloy steel

Slot nuts: Tempered steel

Free of copper, PTFE and silicone

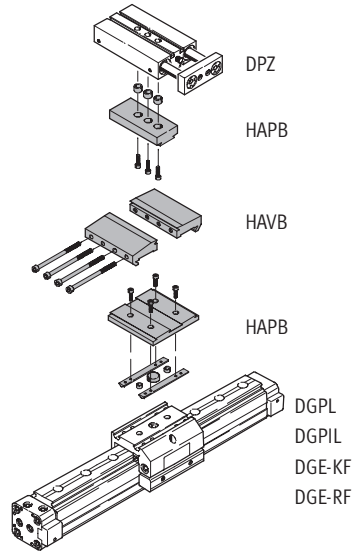

Dovetail mounting

Ordering data		Download CAD data → <a href="http://www.festo.com/en/engineering">www.festo.com/en/engineering</a>	
Drive	Drive	CRC <sup>1)</sup>	Part No. Type <sup>2)</sup>
<b>Dovetail mounting</b>			
DG...-25	DPZ-16	2	163 216 HAPB-17
			163 244 HAVB-8
			163 202 HAPB-3
	DPZ-20		163 217 HAPB-18
			163 244 HAVB-8
			163 202 HAPB-3
DG...-32	DPZ-16		163 216 HAPB-17
			163 244 HAVB-8
			163 203 HAPB-4
	DPZ-20		163 217 HAPB-18
			163 244 HAVB-8
			163 203 HAPB-4
	DPZ-25	163 218 HAPB-19	
		163 244 HAVB-8	
		163 203 HAPB-4	
DG...-40	DPZ-20	163 217 HAPB-18	
		163 244 HAVB-8	
		163 204 HAPB-5	
	DPZ-25	163 218 HAPB-19	
		163 244 HAVB-8	
		163 204 HAPB-5	
	DPZ-32	163 219 HAPB-20	
		163 244 HAVB-8	
		163 204 HAPB-5	

1) Corrosion resistance class 2 to Festo standard 940 070

Components subject to moderate corrosion stress. Externally visible parts with primarily decorative surface requirements which are in direct contact with a normal industrial environment or media such as coolants or lubricating agents

2) Dimensions from → 5 / 3.2-36

# DG.../DSL combination

Technical data

## Adapter kit HAPB, connecting kit HAVB

Material:  
 Wrought aluminium alloy, anodised  
 Centring sleeves: High-alloy steel  
 Slot nuts: Tempered steel  
 Free of copper, PTFE and silicone

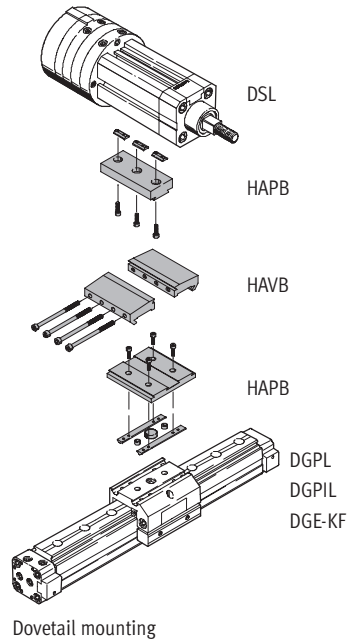

Ordering data		Download CAD data → <a href="http://www.festo.com/en/engineering">www.festo.com/en/engineering</a>	
Drive	Drive	CRC <sup>1)</sup>	Part No. Type <sup>2)</sup>
<b>Dovetail mounting</b>			
DG...-25	DSL-16/20	2	163 214 HAPB-15
			163 244 HAVB-8
			163 202 HAPB-3
	DSL-25		163 215 HAPB-16
			163 244 HAVB-8
			163 202 HAPB-3
DG...-32	DSL-20		163 214 HAPB-15
			163 244 HAVB-8
			163 203 HAPB-4
	DSL-25/32		163 215 HAPB-16
			163 244 HAVB-8
			163 203 HAPB-4
DG...-40	DSL-25/32	163 215 HAPB-16	
		163 244 HAVB-8	
		163 204 HAPB-5	

1) Corrosion resistance class 2 to Festo standard 940 070  
 Components subject to moderate corrosion stress. Externally visible parts with primarily decorative surface requirements which are in direct contact with a normal industrial environment or media such as coolants or lubricating agents

2) Dimensions from → 5 / 3.2-36

# Drive/drive connectors

Technical data



## Dimensions

Download CAD data → [www.festo.com/en/engineering](http://www.festo.com/en/engineering)

### Dovetail mounting

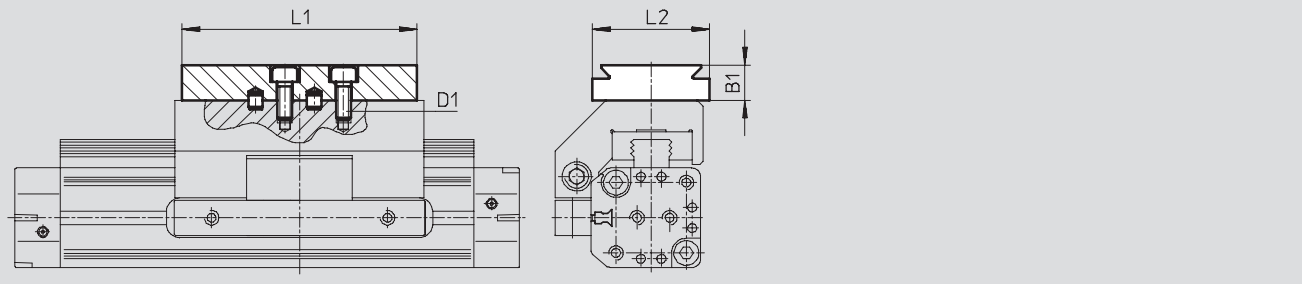

Type	B1	D1	L1	L2	CRC <sup>1)</sup>
HAPB-1	12	M4	60	40	2
HAPB-2		M5	80		2

### Dovetail mounting

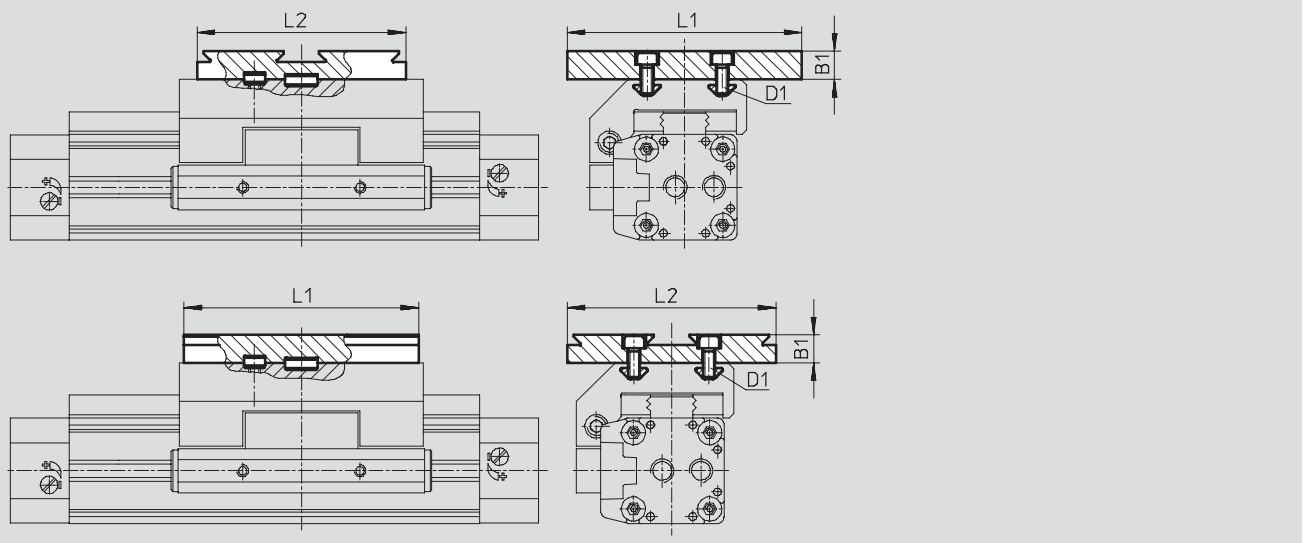

Type	B1	D1	L1	L2	CRC <sup>1)</sup>
HAPB-3	12	M5	100	89	2
HAPB-4					2
HAPB-5					2

1) Corrosion resistance class 2 to Festo standard 940 070

Components subject to moderate corrosion stress. Externally visible parts with primarily decorative surface requirements which are in direct contact with a normal industrial environment or media such as coolants or lubricating agents

# Drive/drive connectors

Technical data



**Dimensions** Download CAD data → [www.festo.com/en/engineering](http://www.festo.com/en/engineering)

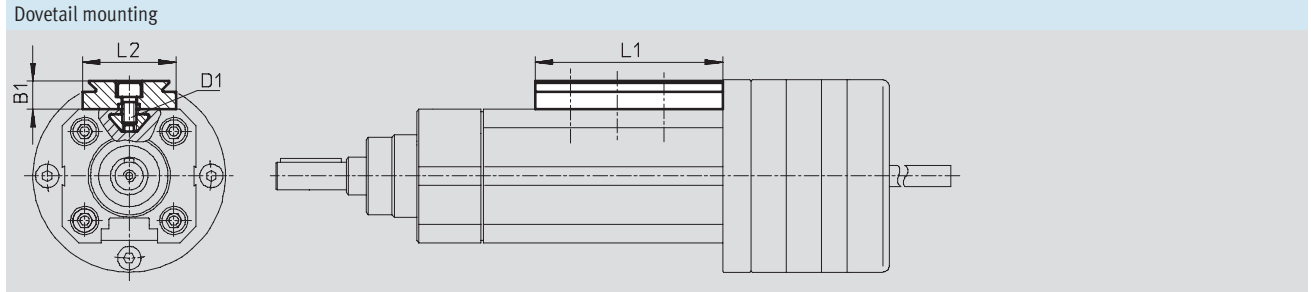

Type	B1	D1	L1	L2	CRC <sup>1)</sup>
HAPB-15	12	M5	80	40	2
HAPB-16		M6			2

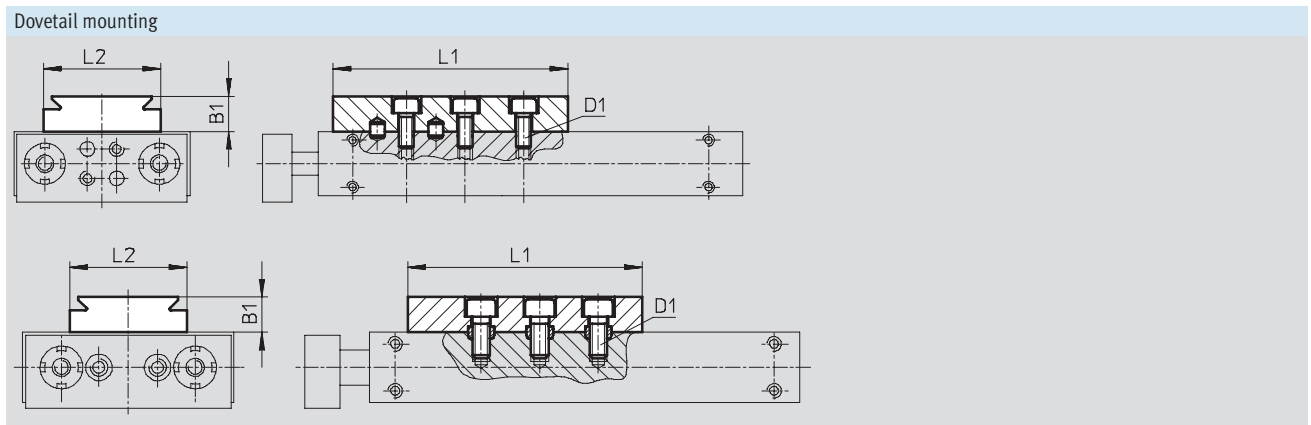

Type	B1	D1	L1	L2	CRC <sup>1)</sup>
HAPB-17	12	M5	80	40	2
HAPB-18		M6			2

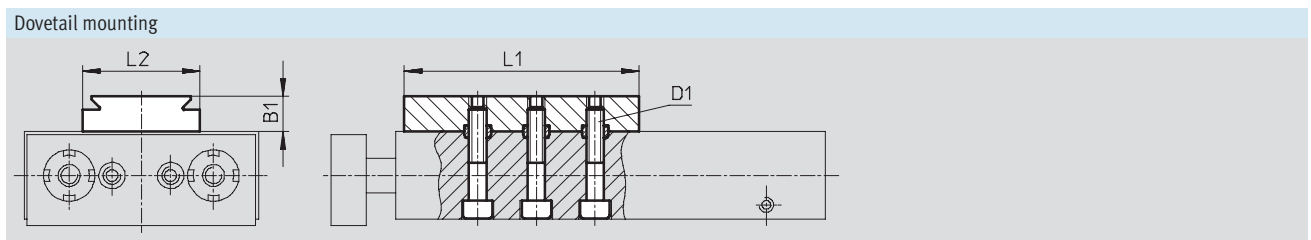

Type	B1	D1	L1	L2	CRC <sup>1)</sup>
HAPB-19	12	M6	80	40	2
HAPB-20					2

1) Corrosion resistance class 2 to Festo standard 940 070  
 Components subject to moderate corrosion stress. Externally visible parts with primarily decorative surface requirements which are in direct contact with a normal industrial environment or media such as coolants or lubricating agents

# Drive/drive connectors

Technical data



**Dimensions** Download CAD data → [www.festo.com/en/engineering](http://www.festo.com/en/engineering)

Dovetail mounting

Assembly of two adapter kits with one connecting kit

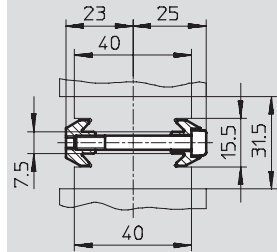

Assembly of two adapter kits with two connecting kits

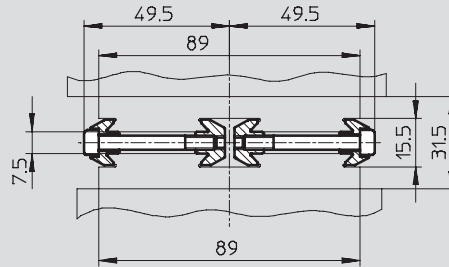

Type	Length L1 <sup>1)</sup>	CRC <sup>2)</sup>
	[mm]	
HAVB-2	40	2
HAVB-3	60	2
HAVB-4	80	2
HAVB-5	100	2

Dovetail mounting

Assembly of two adapter kits with one connecting kit

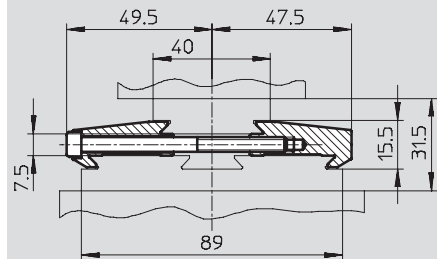

Type	Length L1 <sup>1)</sup>	CRC <sup>2)</sup>
	[mm]	
HAVB-7	60	2
HAVB-8	80	2
HAVB-9	100	2

1) Length of the connecting kit: compare with length L1 of the adapter kits HAPB

2) Corrosion resistance class 2 to Festo standard 940 070

Components subject to moderate corrosion stress. Externally visible parts with primarily decorative surface requirements which are in direct contact with a normal industrial environment or media such as coolants or lubricating agents

System components  
Adapters

3.2

# DG...-HD/HMP, HME combination

Technical data

## Adapter kit HMAV-HD

Material:  
Wrought aluminium alloy, anodised  
Centring sleeves: High-alloy steel  
Slot nuts: Tempered steel  
Free of copper, PTFE and silicone

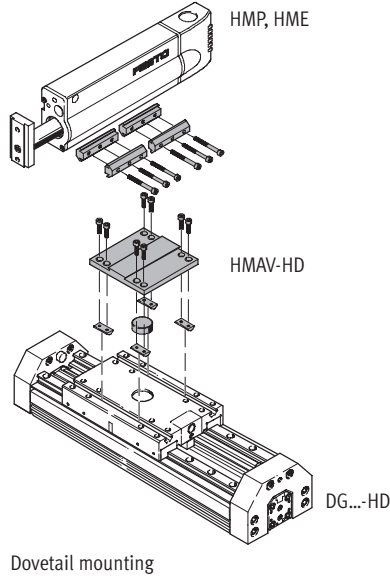

## Dimensions and ordering data

Download CAD data → [www.festo.com/en/engineering](http://www.festo.com/en/engineering)

Dovetail mounting

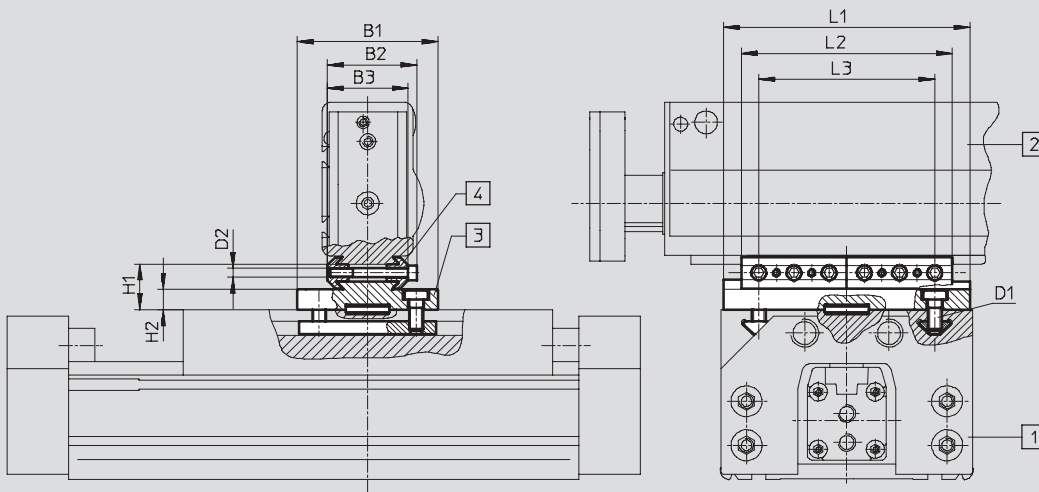

- 1) Linear drives DG... with heavy duty guide HD
  - 2) Linear module HMP, HME<sup>2)</sup>
  - 3) Adapter plate
  - 4) Dovetail clamp
- Adapter kit HMAV-HD, comprising:

Drive	Drive	B1	B2	B3	D1	D2	H1	H2	L1	L2	L3	CRC <sup>1)</sup>	Part No.	Type	
DG...-HD-18	HMP-16/20/25 HME-16/25 <sup>2)</sup>	90			M5		23	8.5	110		80		176 002	HMAV-HD18	
DG...-HD-25	HMP-20/25/32 HME-25 <sup>2)</sup>	80	51	46	M8	M5	26	11.5	140	120	100	2		176 003	HMAV-HD25
DG...-HD-40	HMP-20/25/32 HME-25 <sup>2)</sup>								180		140			176 004	HMAV-HD40

1) Corrosion resistance class 2 to Festo standard 940 070  
Components subject to moderate corrosion stress. Externally visible parts with primarily decorative surface requirements which are in direct contact with a normal industrial environment or media such as coolants or lubricating agents

2) HME: Horizontal mounting position, vertical on request

# DPZ, SPZ/DPZ, SPZ combination

Technical data



## Adapter plate BPL

Material:  
Wrought aluminium alloy, anodised  
Centring sleeves: High-alloy steel  
Free of copper, PTFE and silicone

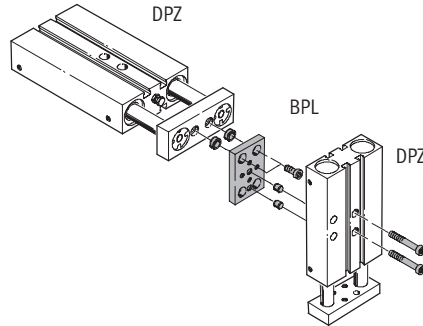

Direct mounting

### Dimensions and ordering data

Download CAD data → [www.festo.com/en/engineering](http://www.festo.com/en/engineering)

Direct mounting

BPL-1

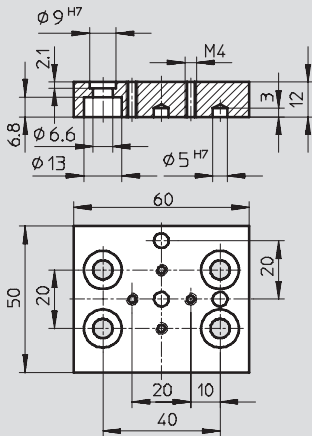

BPL-2

BPL-3 (dimensions in brackets)

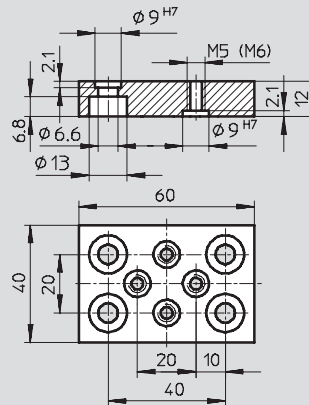

Drive	Drive	CRC <sup>1)</sup>	Part No.	Type
DPZ/SPZ-20/25/32	DPZ/SPZ-10/16	2	150 929	BPL-1
DPZ/SPZ-20/25/32	DPZ/SPZ-20		150 930	BPL-2
DPZ/SPZ-25/32	DPZ/SPZ-25		150 931	BPL-3
DPZ/SPZ-32	DPZ/SPZ-32			

1) Corrosion resistance class 2 to Festo standard 940 070  
Components subject to moderate corrosion stress. Externally visible parts with primarily decorative surface requirements which are in direct contact with a normal industrial environment or media such as coolants or lubricating agents



# Product Range and Company Overview

## A Complete Suite of Automation Services

Our experienced engineers provide complete support at every stage of your development process, including: conceptualization, analysis, engineering, design, assembly, documentation, validation, and production.



**Custom Automation Components**  
Complete custom engineered solutions



**Custom Control Cabinets**  
Comprehensive engineering support and on-site services



**Complete Systems**  
Shipment, stocking and storage services

## The Broadest Range of Automation Components

With a comprehensive line of more than 30,000 automation components, Festo is capable of solving the most complex automation requirements.



**Electromechanical**  
Electromechanical actuators, motors, controllers & drives



**Pneumatics**  
Pneumatic linear and rotary actuators, valves, and air supply



**PLCs and I/O Devices**  
PLC's, operator interfaces, sensors and I/O devices

## Supporting Advanced Automation... As No One Else Can!

Festo is a leading global manufacturer of pneumatic and electromechanical systems, components and controls for industrial automation, with more than 12,000 employees in 56 national headquarters serving more than 180 countries. For more than 80 years, Festo has continuously elevated the state of manufacturing with innovations and optimized motion control solutions that deliver higher performing, more profitable automated manufacturing and processing equipment. Our dedication to the advancement of automation extends beyond technology to the education and development of current and future automation and robotics designers with simulation tools, teaching programs, and on-site services.

## Quality Assurance, ISO 9001 and ISO 14001 Certifications

Festo Corporation is committed to supply all Festo products and services that will meet or exceed our customers' requirements in product quality, delivery, customer service and satisfaction.

To meet this commitment, we strive to ensure a consistent, integrated, and systematic approach to management that will meet or exceed the requirements of the ISO 9001 standard for Quality Management and the ISO 14001 standard for Environmental Management.

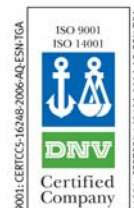

© Copyright 2008, Festo Corporation. While every effort is made to ensure that all dimensions and specifications are correct, Festo cannot guarantee that publications are completely free of any error, in particular typing or printing errors. Accordingly, Festo cannot be held responsible for the same. For Liability and Warranty conditions, refer to our "Terms and Conditions of Sale", available from your local Festo office. All rights reserved. No part of this publication may be reproduced, distributed, or transmitted in any form or by any means, electronic, mechanical, photocopying or otherwise, without the prior written permission of Festo. All technical data subject to change according to technical update.



Printed on recycled paper at New Horizon Graphic, Inc., FSC certified as an environmentally friendly printing plant.

# Festo North America

## United States

**Customer Resource Center**  
502 Earth City Expy., Suite 125  
Earth City, MO 63045

For ordering assistance, or to find  
your nearest Festo Distributor,

**Call:** 1.800.99.FESTO

**Fax:** 1.800.96.FESTO

**Email:** [customer.service@us.festo.com](mailto:customer.service@us.festo.com)

For technical support,

**Call:** 1.866.GO.FESTO

**Fax:** 1.800.96.FESTO

**Email:** [product.support@us.festo.com](mailto:product.support@us.festo.com)

### Headquarters

Festo Corporation  
395 Moreland Road  
P.O. Box 18023  
Hauppauge, NY 11788  
[www.festo.com/us](http://www.festo.com/us)

---

### Sales Offices

#### Appleton

N. 922 Tower View Drive, Suite N  
Greenville, WI 54942

#### Boston

120 Presidential Way, Suite 330  
Woburn, MA 01801

#### Chicago

1441 East Business Center Drive  
Mt. Prospect, IL 60056

#### Dallas

1825 Lakeway Drive, Suite 600  
Lewisville, TX 75057

#### Detroit - Automotive Engineering Center

2601 Cambridge Court, Suite 320  
Auburn Hills, MI 48326

#### New York

395 Moreland Road  
Hauppauge, NY 11788

#### Silicon Valley

4935 Southfront Road, Suite F  
Livermore, CA 94550

## Design and Manufacturing Operations



**East:** 395 Moreland Road, Hauppauge, NY 11788



**Central:** 1441 East Business Center Drive, Mt. Prospect, IL 60056



**West:** 4935 Southfront Road, Suite F, Livermore, CA 94550

---

## Mexico

### Headquarters

Festo Pneumatic, S.A.  
Av. Ceylán 3, Col. Tequesquahuac  
54020 Tlalnepantla, Edo. de México  
**Call:** 011 52 [55] 53 21 66 00  
**Fax:** 011 52 [55] 53 21 66 65  
**Email:** [festo.mexico@mx.festo.com](mailto:festo.mexico@mx.festo.com)  
[www.festo.com/mx](http://www.festo.com/mx)



---

## Canada

### Headquarters

Festo Inc.  
5300 Explorer Drive  
Mississauga, Ontario L4W 5G4  
**Call:** 1.905.624.9000  
**Fax:** 1.905.624.9001  
**Email:** [info.ca@ca.festo.com](mailto:info.ca@ca.festo.com)  
[www.festo.com/ca](http://www.festo.com/ca)



---

## Festo Worldwide

Argentina Australia Austria Belarus Belgium Brazil Bulgaria Canada Chile China Colombia Croatia Czech Republic Denmark  
Estonia Finland France Germany Great Britain Greece Hong Kong Hungary India Indonesia Iran Ireland Israel Italy Japan  
Latvia Lithuania Malaysia Mexico Netherlands New Zealand Norway Peru Philippines Poland Romania Russia Serbia Singapore  
Slovakia Slovenia South Africa South Korea Spain Sweden Switzerland Taiwan Thailand Turkey Ukraine United States Venezuela

[www.festo.com](http://www.festo.com)