

Electric slides EGSK/EGSP

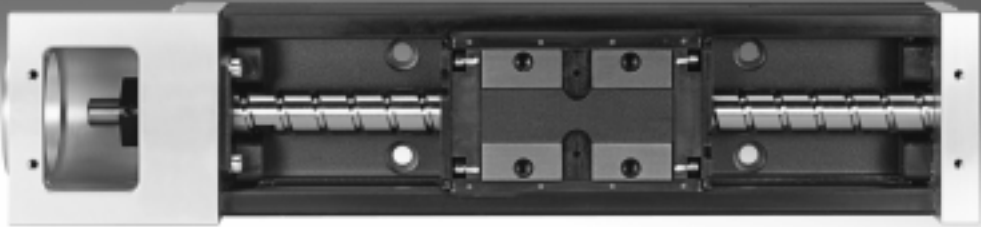

Electromechanical drives

Selection aid

Overview of toothed belt and spindle axes

Toothed belt axes

- Speeds of up to 10 m/s
- Acceleration of up to 50 m/s²
- Repetition accuracy of up to ±0.08 mm
- Strokes of up to 8500 mm (longer strokes on request)
- Flexible motor mounting

Spindle axes

- Speeds of up to 2 m/s
- Acceleration of up to 20 m/s²
- Repetition accuracy of up to ±0.003 mm
- Strokes of up to 3000 mm

Coordinate system

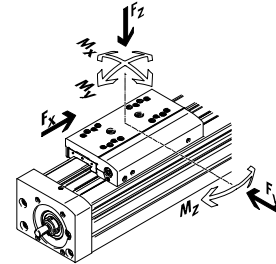

Toothed belt axes

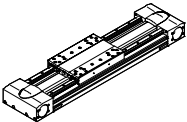
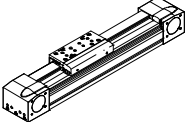
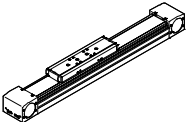
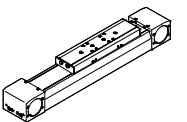
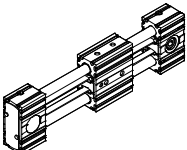
Type	F_x [N]	v [m/s]	M_x [Nm]	M_y [Nm]	M_z [Nm]	Key features
Heavy-duty recirculating ball bearing guide						
EGC-HD-TB						
	450 1000 1800	3 5 5	140 300 900	275 500 1450	275 500 1450	<ul style="list-style-type: none"> • Flat drive unit with rigid, closed profile • Precision DUO guide rail with high load capacity • Ideal as a basic axis for linear gantries and cantilever axes
Recirculating ball bearing guide						
EGC-TB-KF						
	50 100 350 800 2500	3 5 5 5 5	3.5 16 36 144 529	10 132 228 680 1820	10 132 228 680 1820	<ul style="list-style-type: none"> • Rigid, closed profile • Precision guide rail with high load capacity • Small drive pinions reduce required driving torque • Space-saving position sensing
ELGA-TB-KF						
	350 800 1300 2000	5 5 5 5	16 36 104 167	132 228 680 1150	132 228 680 1150	<ul style="list-style-type: none"> • Internal guide and toothed belt • Precision guide rail with high load capacity • Guide and toothed belt protected by cover strip • High feed forces
ELGA-TB-KF-F1						
	260 600 1000	5 5 5	16 36 104	132 228 680	132 228 680	<ul style="list-style-type: none"> • Suitable for use in the food zone • "Clean Look": smooth, easy to clean surfaces • Internal guide and toothed belt • Precision guide rail with high load capacity • Guide and toothed belt protected by cover strip
ELGR-TB						
	50 100 350	3 3 3	2.5 5 15	20 40 124	20 40 124	<ul style="list-style-type: none"> • Cost-optimised rod guide • Ready-to-install unit • Ball bearings with high load capacity for dynamic operation

Electromechanical drives

Selection aid

Overview of toothed belt and spindle axes

Toothed belt axes

- Speeds of up to 10 m/s
- Acceleration of up to 50 m/s²
- Repetition accuracy of up to ±0.08 mm
- Strokes of up to 8500 mm (longer strokes on request)
- Flexible motor mounting

Spindle axes

- Speeds of up to 2 m/s
- Acceleration of up to 20 m/s²
- Repetition accuracy of up to ±0.003 mm
- Strokes of up to 3000 mm

Coordinate system

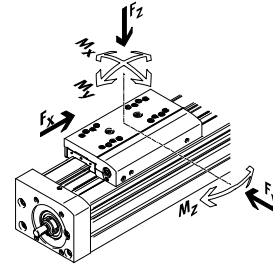

Toothed belt axes

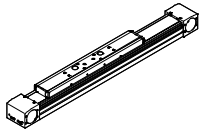
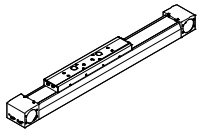
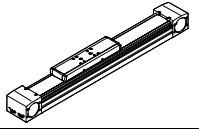
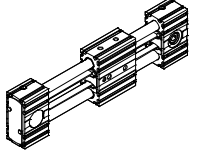
Type	F_x [N]	v [m/s]	M_x [Nm]	M_y [Nm]	M_z [Nm]	Key features
Roller bearing guide						
ELGA-TB-RF						
	350 800 1300	10 10 10	11 30 100	40 180 640	40 180 640	<ul style="list-style-type: none"> • Heavy-duty roller bearing guide • Guide and toothed belt protected by cover strip • Speeds of up to 10 m/s • Lower weight than axes with guide rails
ELGA-TB-RF-F1						
	260 600 1000	10 10 10	8.8 24 80	32 144 512	32 144 512	<ul style="list-style-type: none"> • Suitable for use in the food zone • "Clean Look": smooth, easy to clean surfaces • Heavy-duty roller bearing guide • Guide and toothed belt protected by cover strip • Lower weight than axes with guide rails
Plain-bearing guide						
ELGA-TB-G						
	350 800 1300	5 5 5	5 10 120	30 60 120	10 20 40	<ul style="list-style-type: none"> • Guide and toothed belt protected by cover strip • For simple handling tasks • As a drive component for external guides • Insensitive to harsh operating conditions
ELGR-TB-GF						
	50 100 350	1 1 1	1 2.5 1	10 20 40	10 20 40	<ul style="list-style-type: none"> • Cost-optimised rod guide • Ready-to-install unit • Heavy-duty plain bearings for use in harsh operating conditions

Electromechanical drives

Selection aid

Overview of toothed belt and spindle axes

Toothed belt axes

- Speeds of up to 10 m/s
- Acceleration of up to 50 m/s²
- Repetition accuracy of up to ±0.08 mm
- Strokes of up to 8500 mm (longer strokes on request)
- Flexible motor mounting

Spindle axes

- Speeds of up to 2 m/s
- Acceleration of up to 20 m/s²
- Repetition accuracy of up to ±0.003 mm
- Strokes of up to 3000 mm

Coordinate system

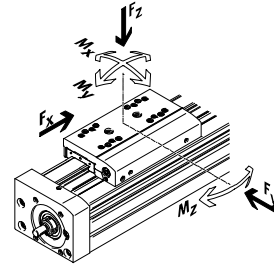

Spindle axes

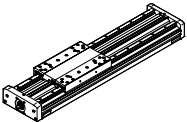
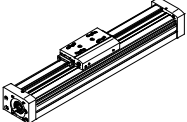
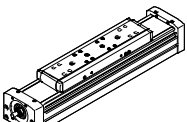
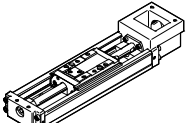
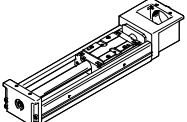
Type	F_x [N]	v [m/s]	M_x [Nm]	M_y [Nm]	M_z [Nm]	Key features
Heavy-duty recirculating ball bearing guide						
EGC-HD-BS						
	300 600 1300	0.5 1.0 1.5	140 300 900	275 500 1450	275 500 1450	<ul style="list-style-type: none"> • Flat drive unit with rigid, closed profile • Precision DUO guide rail with high load capacity • Ideal as a basic axis for linear gantries and cantilever axes
Recirculating ball bearing guide						
EGC-BS-KF						
	300 600 1300 3000	0.5 1.0 1.5 2.0	16 36 144 529	132 228 680 1820	132 228 680 1820	<ul style="list-style-type: none"> • Rigid, closed profile • Precision guide rail with high load capacity • For the highest requirements in terms of feed force and accuracy • Space-saving position sensing
ELGA-BS-KF						
	300 600 1300 3000	0.5 1.0 1.5 2.0	16 36 104 167	132 228 680 1150	132 228 680 1150	<ul style="list-style-type: none"> • Internal guide and ball screw • Precision guide rail with high load capacity • For the highest requirements in terms of feed force and accuracy • Guide and ball screw protected by cover strip • Space-saving position sensing
EGSK						
	57 133 184 239 392	0.33 1.10 0.83 1.10 1.48	13 28.7 60 79.5 231	3.7 9.2 20.4 26 77.3	3.7 9.2 20.4 26 77.3	<ul style="list-style-type: none"> • Spindle axes with maximum precision, compactness and rigidity • Recirculating ball bearing guide and ball screw without caged ball bearings • Standard designs in stock
EGSP						
	112 212 466 460	0.6 0.6 2.0 2.0	36.3 81.5 90.3 258	12.5 31.6 32.1 94	12.5 31.6 32.1 94	<ul style="list-style-type: none"> • Spindle axes with maximum precision, compactness and rigidity • Recirculating ball bearing guide with caged ball bearings • Ball screw sizes 33, 46 with caged ball bearings

Electric slides EGSK/EGSP

Key features

At a glance

Precision embedded in steel

The new generation of electric slide axes EGSK and EGSP impresses with its precision, repetition accuracy, compactness and rigidity.

The two axis series form a complete range with a uniform design, long service life and standardised mounting interfaces. The U-shaped steel housing serves simultaneously as

a guide rail. The slide combines linear guide elements and the spindle nuts of the ball screw in one component, thus avoiding the accumulation of production tolerances.

Both series come in three accuracy classes with the option of an additional slide (series 33 and 46 are also available in a short-slide design).

Electric slide EGSK

- Recirculating ball bearing guide and ball screw without caged balls
- Standard designs available ex-stock

Electric slide EGSP

- Recirculating ball bearing guide with caged balls
- Size 33, 46 features a ball screw with caged balls
- Low-maintenance
- Uniform operating behaviour with very low noise levels

Linear guide with caged balls

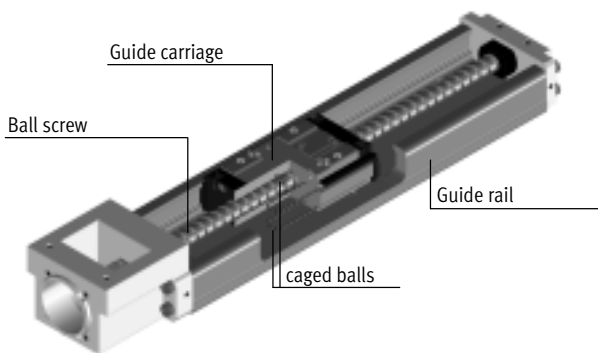

The linear guide features four rows of balls circulating within the guide carriage. In the loaded area, the balls run between the honed grooves of the guide carriage and guide rail until they are returned by means of the reversers in the end plates and the return channels. The very rigid design of the guide carriage enables precision

linear movements to be executed with impressive dynamism. The four rows of balls are arranged at a contact angle of 45°, giving the guide carriage the same basic load ratings in both radial coordinate directions. This type of guide can therefore be used in any mounting position for a wide range of load directions.

Axis characteristics

The specifications shown in the table are maximum values.

The precise values for each of the variants can be found in the relevant technical data section.

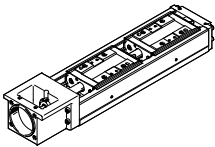
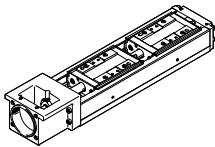
Design	Size	Working stroke [mm]	Speed [m/s]	Repetition accuracy [µm]	Feed force [N]	Guide characteristics				
						Forces and torques				
						Fy [N]	Fz [N]	Mx [Nm]	My [Nm]	Mz [Nm]
Electric slide EGSK						→ page 8				
	15	25 ... 100	0.33	±3	57	1185	1185	13	3.7	3.7
	20	25 ... 125	1.10	±3	133	2204	2204	28.7	9.2	9.2
	26	50 ... 200	0.83	±3	184	3528	3528	60	20.4	20.4
	33	100 ... 630	1.10	±3	239	3920	3920	79.5	26	26
	46	200 ... 840	1.48	±3	392	7809	7809	231	77.3	77.3
Electric slide EGSP						→ page 24				
	20	25 ... 125	0.6	±3	112	2929	2929	36.3	12.5	12.5
	26	50 ... 200	0.6	±3	212	5028	5028	81.5	31.6	31.6
	33	100 ... 630	2	±3	466	4559	4559	90.3	32.1	32.1
	46	200 ... 840	2	±3	460	8935	8935	258	94	94

Electric slides EGSK/EGSP

Key features

Complete system comprising electric slide, motor, motor controller and motor mounting kit
Electric slide with recirculating ball bearing guide



Motor

→ page 37



- 1 Servo motor EMME-AS, EMMS-AS
- 2 Stepper motor EMMS-ST



Note

A range of specially matched complete solutions is available for the electric slides EGSK, EGSP and the motors.

Motor controller

Technical data → Internet: motor controller



- 1 Servo motor controller CMMP-AS
- 2 Stepper motor controller CMMS-ST

Motor mounting kit

→ page 37

Axial kit



Kit comprising:

- Motor flange
- Coupling
- Screws

Electric slides EGSK/EGSP

Peripherals overview

FESTO

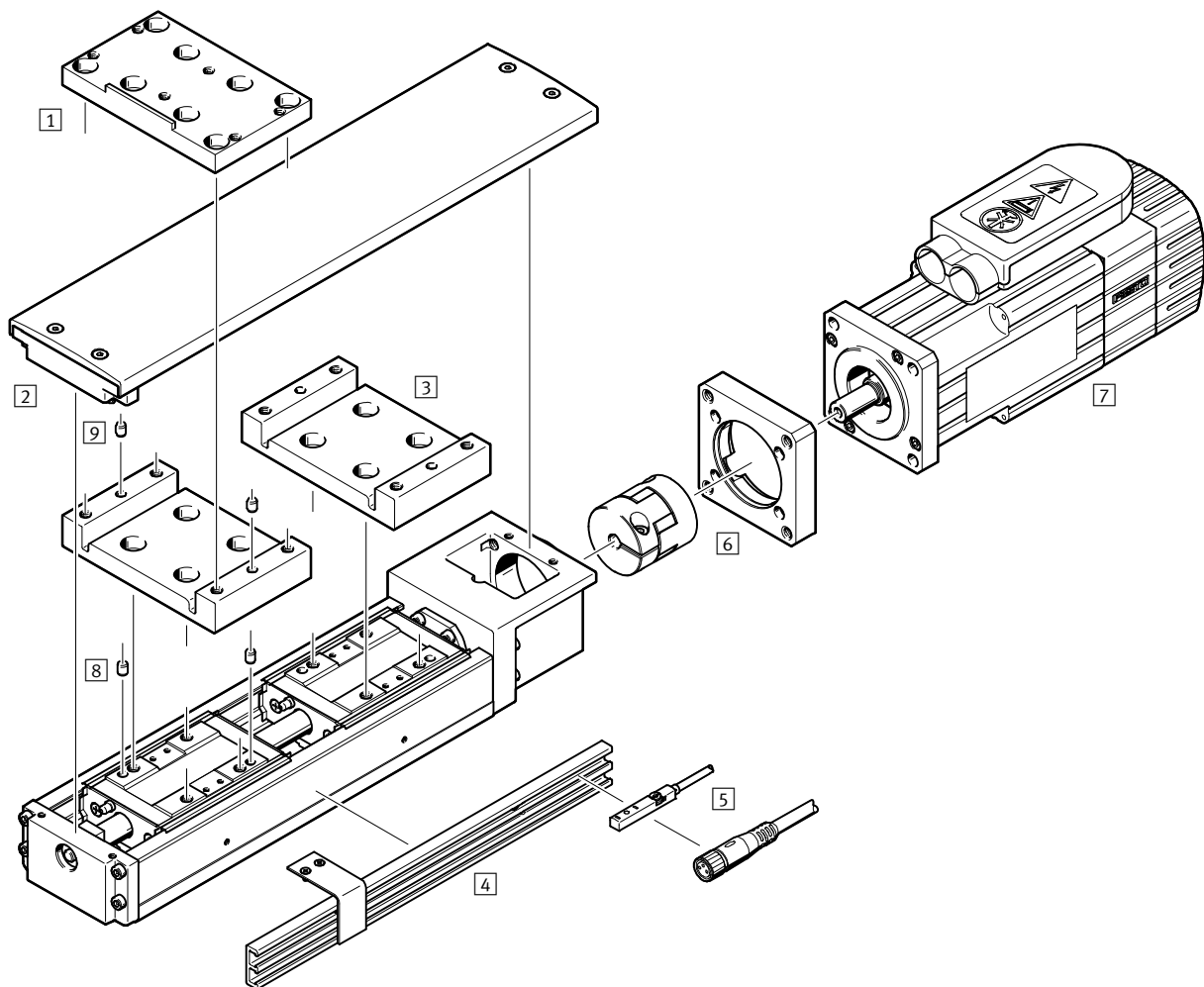

Accessories			
	Type	Brief description	→ Page/Internet
1	Cross connecting kit EHAM-S1	For mounting an assembly axis EGSK/EGSP at right angles on the slide of a basic axis EGSK/EGSP. The assembly axis is one size smaller than the respective basic axis.	40
2	Covering kit EASC-S1	For covering the axis profile that is open at the top. The kit includes a slide adapter EASA-S1.	42
3	Slide adapter EASA-S1	Required to mount the effective load in combination with the covering kit for axis variants with additional slide.	41
4	Sensor strip EAPR-S1-S	<ul style="list-style-type: none"> For mounting the inductive proximity sensor SIES-8M on the electric slide. Switching lugs are included in the scope of delivery. 	44
5	Proximity sensor SIES-8M	Inductive proximity sensor, for T-slot.	45
6	Axial kit EAMM-A	For axial motor mounting (comprising: coupling and motor flange).	37
7	Motor EMME, EMMS	Motors specially matched to the axis, with or without brake.	37
8	Centring pin ZBS	For centring loads and attachments on the slide.	45
9	Centring pin ZBS	For centring loads and attachments on the slide adapter.	45

Electric slides EGSK

Type codes

		EGSK	-	20	-	125	-	6P	-	H	-		-	Z
Type														
EGSK	Electric slide													
Size														
Stroke [mm]														
Spindle pitch														
Accuracy														
-	Standard													
H	High accuracy													
P	Precision design													
Slide design														
-	Standard slide													
S	Slide, short													
Additional slide														
-	No additional slide													
Z	Additional slide													



Electric slides EGSK

Technical data

FESTO

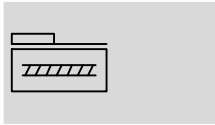
Function



-  Size
15 ... 46
-  Stroke length
25 ... 840 mm



General technical data													
Size		15 ²⁾		20		26		33		46			
Spindle pitch		1	2	1	6	2	6	6	10	10	20		
		Code ¹⁾											
Constructional design		Electromechanical linear axis with recirculating ball bearing spindle											
Guide		Recirculating ball bearing guide											
Installation position		Any											
Type of mounting for effective load		Female thread											
		Centring sleeve				Locating pin							
Working stroke ³⁾	-	[mm]		25 ... 100		25 ... 125		50 ... 200		100 ... 600		200 ... 800	
	S	[mm]		-		-		-		130 ... 630		240 ... 840	
Max. feed force	-/H ⁴⁾	[N]		36	19	69	72	116	116	150	148	264	192
F _{x,max}	P ⁵⁾	[N]		57	31	110	133	184	184	239	183	392	343
Max. driving torque	-/H ⁴⁾	[Ncm]		0.6	0.6	1.1	6.9	3.7	11	14	24	42	61
M _{Driving,max}	P ⁵⁾	[Ncm]		0.9	1.0	1.8	13	5.9	18	23	29	62	109
No-load torque	-/H	[Ncm]		0.4	0.4	0.5	0.5	1.5	1.5	7	7	10	10
M _{No-load}	P	[Ncm]		0.8	0.8	1.2	1.2	4.0	4.0	15	15	17	17
Max. rotational speed ⁶⁾		[1/min]		9600	9900	11400	7900	8400	5900	4700	4700	3100	3100
Max. speed ⁶⁾	-/H	[m/s]		0.16	0.33	0.19	0.79	0.28	0.59	0.47	0.79	0.52	1.05
	P	[m/s]		0.16	0.33	0.19	1.10	0.28	0.83	0.66	1.10	0.74	1.48
Max. acceleration		[m/s ²]		10		10		10		20		20	
Homing		Inductive proximity sensor SIES-8M											

- 1) Variant code → page 8
- 2) Size 15 only comes in the accuracy classes H and P
- 3) Maximum travel distance → page 17
In combination with an additional slide, the working stroke is reduced by the length of the additional slide and the distance between the two slides
- 4) Loads are based on a service life specification of 5 x 10⁸ rotations
- 5) Loads are based on a service life specification of 1.25 x 10⁸ rotations
- 6) Reduced speeds with sizes 33 and 46 with long strokes → page 11

Operating and environmental conditions		
Ambient temperature	[°C]	0 ... +40
Relative air humidity	[%]	0 ... 95 (non-condensing)

Weight [kg]											
Size		15		20		26		33		46	
		Code ¹⁾									
Basic weight with 0 mm stroke ²⁾	-			0.16	0.38	0.78		1.38		5.17	
	S			-	-	-		1.28		4.77	
Additional weight per 100 mm stroke	-			0.12	0.27	0.42		0.63		1.27	
Moving load	-			0.04	0.07	0.15		0.31		0.91	
	S			-	-	-		0.17		0.57	
Additional slide Z	-			0.04	0.07	0.15		0.31		0.91	
	S			-	-	-		0.17		0.57	

- 1) Variant code → page 8
- 2) Including slide, without additional slide

Electric slides EGSK

Technical data

FESTO

Accuracy data [µm]			15		20		26		33		46	
Size	Stroke	Code ¹⁾										
Repetition accuracy ²⁾		–	–	–	±10	±10	±10	±10	±10	±10	±10	±10
		H	±4	±5	±5	±5	±5	±5	±5	±5	±5	±5
		P	±3	±3	±3	±3	±3	±3	±3	±3	±3	±3
Operating parallelism	25 ... 340	H	20	25	25	25	25	25	25	25	25	35
	400 ... 540	H	–	–	–	–	–	–	–	–	–	35
	600 ... 640	H	–	–	–	–	–	–	–	–	–	40
	800 ... 840	H	–	–	–	–	–	–	–	–	–	50
	25 ... 340	P	10	10	10	10	10	10	10	10	10	15
	400 ... 540	P	–	–	–	–	–	–	–	–	–	15
	600 ... 640	P	–	–	–	–	–	–	–	–	–	20
Max. reversing play		–	–	–	20	20	20	20	20	20	20	20
		H	10	10	10	10	10	10	10	10	10	20
		P	2	3	3	3	3	3	3	3	3	3

1) Variant code → page 8

2) The repetition accuracy that can be achieved with a motor/axis system is also influenced by the angle resolution of the motor and the chosen control parameters. The specified repetition accuracy cannot, therefore, be achieved with all motors.

Materials

Sectional view

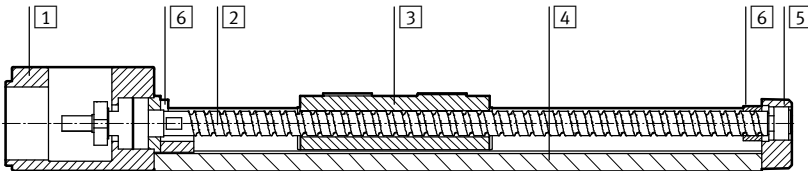

Electric slide

1	Drive cover	Die-cast aluminium, coated
2	Spindle	Steel
3	Slide	Steel
4	Profile	High-alloy steel
5	End cap	Die-cast aluminium, coated
6	Buffer	Ethylene vinyl acetate copolymer
Note on materials		RoHS-compliant
		Contains PWIS (paint-wetting impairment substances)

Mass moment of inertia

Size		15		20		26		33		46	
Spindle pitch		1	2	1	6	2	6	6	10	10	20
	Code ¹⁾										
J ₀	[kg mm ²]	0.030	0.033	0.087	0.144	0.357	0.481	1.15	1.66	8.47	15.4
	S [kg mm ²]	–	–	–	–	–	–	0.795	1.07	6.04	10.4
J _S per 100 mm stroke	[kg mm ² /100 mm]	0.048		0.100		0.316		0.771		3.902	
J _L per kg effective load	[kg mm ² /kg]	0.03	0.10	0.03	0.91	0.10	0.91	0.91	2.53	2.53	10.13
J _W per additional slide	[kg mm ²]	0.001	0.004	0.002	0.058	0.016	0.14	0.28	0.79	2.31	9.22
	S [kg mm ²]	–	–	–	–	–	–	0.16	0.43	1.44	5.78

1) Variant code → page 8

The mass moment of inertia J_A of the entire axis is calculated as follows:

$$J_A = J_0 + J_W + J_S \times \text{working stroke} + J_L \times m_{\text{Effective load}}$$

Electric slides EGSK

Technical data

Speed v, rotational speed n as a function of working stroke l

EGSK-33-...-6P

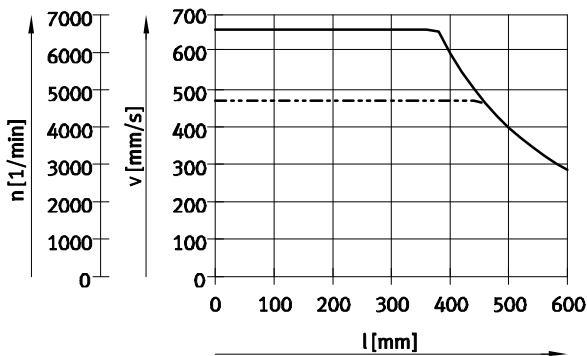

— EGSK-33-...-6P-P
 - - - EGSK-33-...-6P, EGSK-33-...-6P-H

EGSK-33-...-10P

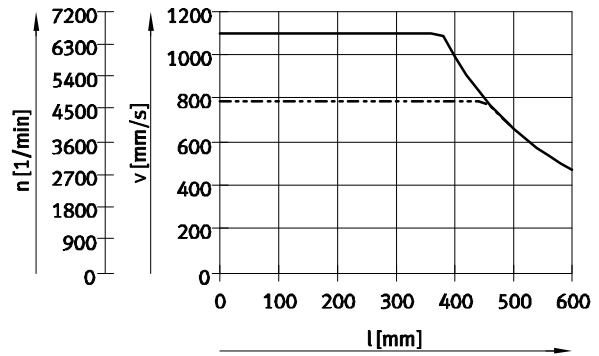

— EGSK-33-...-10P-P
 - - - EGSK-33-...-10P, EGSK-33-...-10P-H

EGSK-46-...-10P

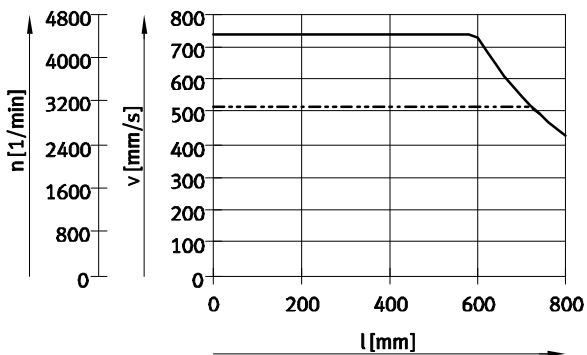

— EGSK-46-...-10P-P
 - - - EGSK-46-...-10P, EGSK-46-...-10P-H

EGSK-46-...-20P

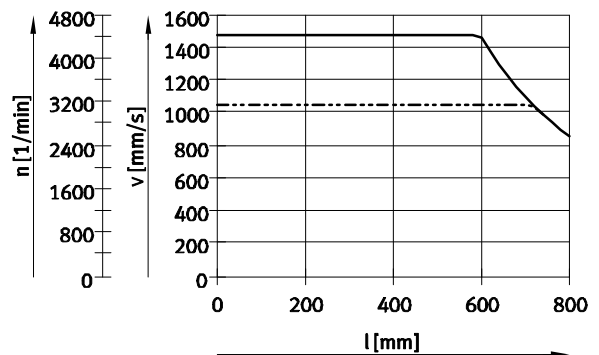

— EGSK-46-...-20P-P
 - - - EGSK-46-...-20P, EGSK-46-...-20P-H

2nd moment of area

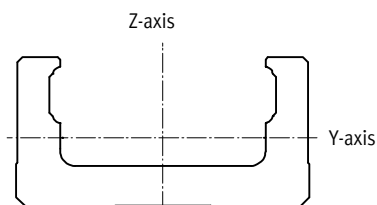

Size		15	20	26	33	46
I_y	[mm ⁴]	908	6100	17000	62000	240000
I_z	[mm ⁴]	14200	62000	150000	380000	1500000

Electric slides EGSK

Technical data



Characteristic load values

The indicated forces and torques refer to the centre axis of the spindle.

The coordinate zero point is the point where the centre of the guide and the longitudinal centre of the slide intersect.

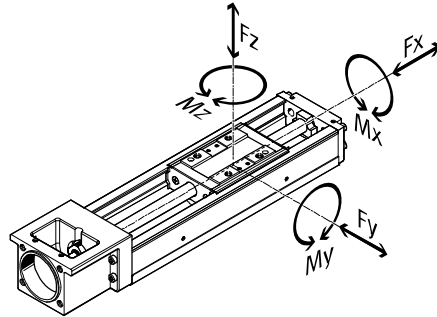

Note
PositioningDrives
sizing software
www.festo.com

Permissible dynamic forces and torques¹⁾

Size			15 ³⁾		20		26		33		46		
Spindle pitch			1	2	1	6	2	6	6	10	10	20	
	Code ²⁾												
F _y max., F _z max.	-/H ⁴⁾	-	[N]	747	593	1389	764	2223	1541	2469	2083	4919	3904
	P ⁵⁾	-	[N]	1185	941	2204	1213	3528	2446	3920	3306	7809	6198
	-/H ⁴⁾	S	[N]	-	-	-	-	-	-	1043	880	2514	1995
	P ⁵⁾	S	[N]	-	-	-	-	-	-	1656	1396	3990	3167
M _x max.	-/H ⁴⁾	-	[Nm]	8.2	6.5	18.1	9.9	37.8	26.2	50.1	42.2	145	115
	P ⁵⁾	-	[Nm]	13	10.3	28.7	15.8	60	41.6	79.5	67.1	231	183
	-/H ⁴⁾	S	[Nm]	-	-	-	-	-	-	21.2	17.8	74.4	59
	P ⁵⁾	S	[Nm]	-	-	-	-	-	-	33.6	28.3	118	93.7
M _y max., M _z max.	-/H ⁴⁾	-	[Nm]	2.3	1.9	5.8	3.2	12.9	8.9	16.4	13.8	48.7	38.7
	P ⁵⁾	-	[Nm]	3.7	2.9	9.2	5.1	20.4	14.1	26	21.9	77.3	61.4
	-/H ⁴⁾	S	[Nm]	-	-	-	-	-	-	3.8	3.2	13.6	10.8
	P ⁵⁾	S	[Nm]	-	-	-	-	-	-	6	5	21.6	17.1

- 1) Calculated with a speed-dependent load factor f_w of 1.2
- 2) Variant code → page 8
- 3) Size 15 only comes in the accuracy classes H and P
- 4) Loads are based on a service life specification of 5×10^8 rotations and a load factor f_w of 1.2
- 5) Loads are based on a service life specification of 1.25×10^8 rotations and a load factor f_w of 1.2

Basic load ratings

Size			15 ²⁾		20		26		33		46	
Spindle pitch			1	2	1	6	2	6	6	10	10	20
	Code ¹⁾											
Ball screw												
Static C ₀ ball screw	-/H	[N]	660	410	1170	1450	4020	3510	4900	2840	6760	7150
	P	[N]	660	410	1170	1600	4020	3900	2740	1570	3720	5290
Dynamic C _{dyn} ball screw	-/H ³⁾	[N]	340	230	660	860	2350	1950	2840	1760	3140	3040
	P ³⁾	[N]	340	230	660	1060	2350	2390	2250	1370	2940	3430
Fixed bearing												
Static C ₀ bearing		[N]	290		1240		1760		2590		3240	
Dynamic C _{dyn} bearing ³⁾		[N]	590		1000		1380		1790		6660	

- 1) Variant code → page 8
- 2) Size 15 only comes in the accuracy classes H and P
- 3) Dynamic basic load ratings are based on a basic service life of 10^6 rotations

Electric slides EGSK

Technical data

Basic load ratings												
Size			15 ²⁾		20		26		33		46	
Spindle pitch			1	2	1	6	2	6	6	10	10	20
Code ¹⁾												
Linear guide												
Static C _{0,guide}	-	[N]	3450	6300	12150	20200	45500					
	S	[N]	-	-	-	10000	22700					
Dynamic C _{dyn,guide} ³⁾	-	[N]	1532	2849	5746	9207	21747					
	S	[N]	-	-	-	3889	11112					
Torque equivalence factors												
k _x	-	[1/m]	90.9	76.9	58.8	49.3	33.8					
	S	[1/m]	-	-	-	49.3	33.8					
k _y , k _z	-	[1/m]	319.9	238.7	172.9	151	101					
	S	[1/m]	-	-	-	277.1	185					

- 1) Variant code → page 8
- 2) Size 15 only comes in the accuracy classes H and P
- 3) Dynamic basic load ratings are based on a basic service life of 100 km

Speed-dependent load factor f_w

- f_w = 1.0 ... 1.2 (v ≤ 0.25 m/s)
- f_w = 1.2 ... 1.5 (0.25 m/s ≤ v ≤ 1.0 m/s)
- f_w = 1.5 ... 2.0 (1.0 m/s ≤ v ≤ 2.0 m/s)
- f_w = 2.0 ... 3.5 (v ≥ 2.0 m/s)

Calculation of the maximum feed force F_x

$$F_{x,max} = \frac{1}{f_w} \times \frac{\text{Min}[C_{dyn,KGT}; C_{dyn,bearing}]}{\sqrt[3]{\frac{l_{ref,rot}}{10^6}}}$$

Calculation of the maximum forces F_{y/z} and torques M_{x/y/z}

$$F_{y/z,max} = \frac{1}{f_w} \times \frac{C_{dyn,guide}}{\sqrt[3]{\frac{l_{ref,km}}{100km}}}$$

$$M_{x/y/z,max} = \frac{1}{k_{x/y/z}} \times \frac{1}{f_w} \times \frac{C_{dyn,guide}}{\sqrt[3]{\frac{l_{ref,km}}{100km}}}$$

Electric slides EGSK

Technical data

FESTO

Calculation of the service life											
Size	15		20		26		33		46		
Spindle pitch P	1	2	1	6	2	6	6	10	10	20	
	Code ¹⁾										
Reference service life	-/H	5 x 10 ⁸									
in rotations, L _{ref,rot}	P	1.25 x 10 ⁸									
Reference service life	-/H [km]	500	1000	500	3000	1000	3000	3000	5000	5000	10000
in kilometres, L _{ref,km}	P [km]	125	250	125	750	250	750	750	1250	1250	2500

1) Variant code → page 8

1 Representation of the loads

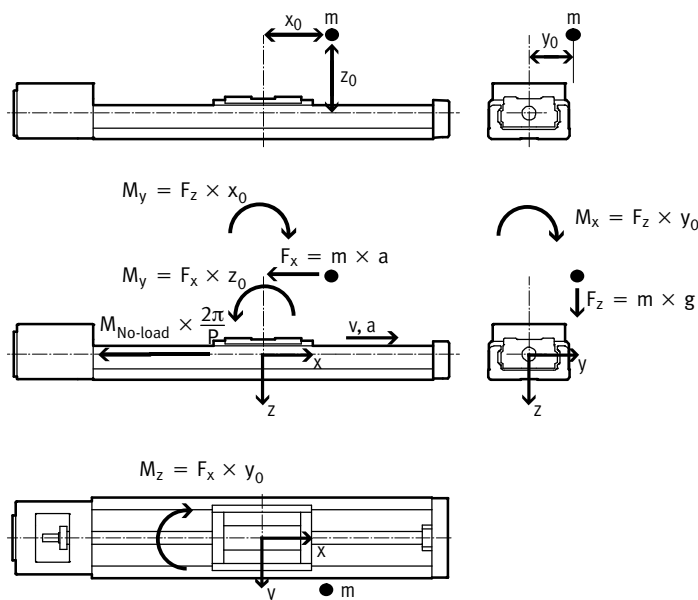

2 Determination of the loads over the travel cycle

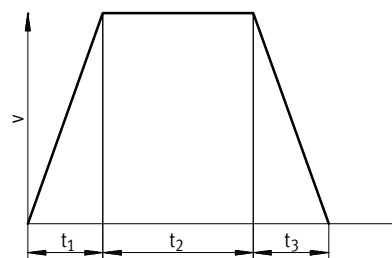

$$q_1 = \frac{t_1}{t_{tot}} \quad q_2 = \frac{t_2}{t_{tot}} \quad q_3 = \frac{t_3}{t_{tot}}$$

$$t_{tot} = t_1 + t_2 + t_3$$

v	Speed
t ₁	Acceleration time
t ₂	Constant travel time
t ₃	Deceleration time
q _{1/2/3}	Relative time of the cycle phases
t _{tot}	Cycle time

Ball screw

For t₁: $F_{x1} = - (m \times a) - (M_{No-load} \times \frac{2\pi}{P})$

For t₂: $F_{x2} = - (M_{No-load} \times \frac{2\pi}{P})$

For t₃: $F_{x3} = m \times a - (M_{No-load} \times \frac{2\pi}{P})$

$$F_{x,dyn} = \sqrt[3]{q_1 \times |F_{x1}|^3 + q_2 \times |F_{x2}|^3 + q_3 \times |F_{x3}|^3}$$

F _{x1/2/3}	Calculated force load per cycle phase
F _{x,dyn}	Calculated average force load
m	Effective load (centre of gravity)
a	Acceleration
M _{No-load}	No-load torque → page 9
P	Spindle pitch → page 9
q _{1/2/3}	Relative time of the cycle phases

2 Determination of the loads over the travel cycle		
Linear guide		
<p>For t₁: a →, v →</p> $F_{y1} = 0$ $F_{z1} = m \times g$ $M_{x1} = F_z \times y_0 = m \times g \times y_0$ $M_{y1} = -F_z \times x_0 + F_x \times z_0 = -m \times g \times x_0 + m \times a \times z_0$ $M_{z1} = F_x \times y_0 = m \times a \times y_0$	$F_{y1/2/3}$ $F_{z1/2/3}$ $M_{x1/2/3}$ $M_{y1/2/3}$ $M_{z1/2/3}$ $F_{y/z,dyn}$ $M_{x/y/z,dyn}$ m g a x_0, y_0, z_0	<p>Calculated force load per cycle phase</p> <p>Calculated torque load per cycle phase</p> <p>Calculated average force load</p> <p>Calculated average torque load</p> <p>Effective load (centre of gravity)</p> <p>Gravitational acceleration</p> <p>Acceleration</p> <p>Distances between the centre of gravity of the effective load and the slide centre point</p> <p>Relative time of the cycle phases</p>
<p>For t₂: a = 0, v →</p> $F_{y2} = 0$ $F_{z2} = m \times g$ $M_{x2} = F_z \times y_0 = m \times g \times y_0$ $M_{y2} = -F_z \times x_0 = -m \times g \times x_0$ $M_{z2} = 0$		
<p>For t₃: a ←, v →</p> $F_{y3} = 0$ $F_{z3} = m \times g$ $M_{x3} = F_z \times y_0 = m \times g \times y_0$ $M_{y3} = -F_z \times x_0 - F_x \times z_0 = -m \times g \times x_0 - m \times a \times z_0$ $M_{z3} = -F_x \times y_0 = -m \times a \times y_0$	$q_{1/2/3}$	
$F_{y,dyn} = \sqrt[3]{q_1 \times F_{y1} ^3 + q_2 \times F_{y2} ^3 + q_3 \times F_{y3} ^3}$ $F_{z,dyn} = \sqrt[3]{q_1 \times F_{z1} ^3 + q_2 \times F_{z2} ^3 + q_3 \times F_{z3} ^3}$ $M_{x,dyn} = \sqrt[3]{q_1 \times M_{x1} ^3 + q_2 \times M_{x2} ^3 + q_3 \times M_{x3} ^3}$ $M_{y,dyn} = \sqrt[3]{q_1 \times M_{y1} ^3 + q_2 \times M_{y2} ^3 + q_3 \times M_{y3} ^3}$ $M_{z,dyn} = \sqrt[3]{q_1 \times M_{z1} ^3 + q_2 \times M_{z2} ^3 + q_3 \times M_{z3} ^3}$		
3 Total load		
Ball screw		
$\frac{ F_{x,dyn} }{F_{x,max}} \leq f_v$	$F_{x,dyn}$ $F_{x,max}$ f_v	<p>Calculated average force load</p> <p>Max. permissible force load → page 9</p> <p>Load comparison factor → page 16</p>
Linear guide		
$\frac{ F_{y,dyn} }{F_{y,max}} + \frac{ F_{z,dyn} }{F_{z,max}} + \frac{ M_{x,dyn} }{M_{x,max}} + \frac{ M_{y,dyn} }{M_{y,max}} + \frac{ M_{z,dyn} }{M_{z,max}} \leq f_v$	$F_{y/z,dyn}$ $F_{y/z,max}$ $M_{x/y/z,dyn}$ $M_{x/y/z,max}$ f_v	<p>Calculated average force load</p> <p>Max. permissible force load → page 12</p> <p>Calculated average torque load</p> <p>Max. permissible torque load → page 12</p> <p>Load comparison factor → page 16</p>

Electric slides EGSK

Technical data

4 Determination of the load comparison factor f_v

$$f_v = \frac{1}{\sqrt[3]{q}} \quad \text{with} \quad q = \frac{L_{\text{calc,km}}}{L_{\text{ref,km}}} = \frac{L_{\text{calc,rot}}}{L_{\text{ref,rot}}}$$

for $q = 1$:

Calculated service life (here desired service life) $L_{\text{calc,km}} = 1 \times$ reference service life $L_{\text{ref,km}}$ gives $f_v = 1$

for $q \neq 1$:

Calculated service life (here desired service life) $L_{\text{calc,km}} = q \times$ reference service life $L_{\text{ref,km}}$ read off (→ graph) or calculate f_v

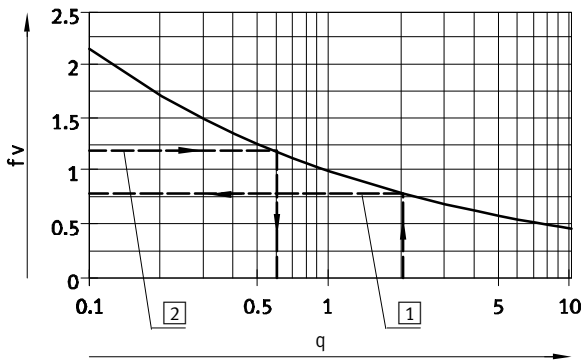

- 1 → Example 1
- 2 → Example 2

f_v	Load comparison factor
q	Quotient of desired service life divided by reference service life
$L_{\text{calc, km}}$	Calculated service life in km
$L_{\text{ref, km}}$	Reference service life in km → page 14
$L_{\text{calc, rot}}$	Calculated service life in rotations
$L_{\text{ref, rot}}$	Reference service life in rotations → page 14

5 Calculation examples

Example 1:

EGSK-26-...-2P-H-...

$L_{\text{ref,km}} = 1000 \text{ km}$

$L_{\text{calc,km}} = 2000 \text{ km}$

$$q = \frac{2000\text{km}}{1000\text{km}} = 2.0$$

$$f_v = \frac{1}{\sqrt[3]{q}} = 0.79$$

Result:

A desired service life of 200% of the reference service life means that the permissible total load must be 21% lower.

Example 2:

If the total load calculation gives a load comparison factor f_v of 1.2, the mathematical service life is only approx. 60% ($x = 0.6$ → graph) of the reference service life.

$$q = \frac{1}{f_v^3} = 0.58$$

6 Static sizing

Ball screw

$$F_{x,\text{stat}} = \text{Max}[F_{x1}, F_{x2}, F_{x3}] \leq \frac{C_{0,\text{KGT}}}{f_s}$$

$F_{x,\text{stat}}$	Maximum value of the calculated force load per cycle phase	$C_{0,\text{KGT}}$	Static basic load rating of ball screw → page 12
$F_{x1/2/3}$	Calculated force load per cycle phase	f_s	Safety factor against static overload $f_s = 1.0 \dots 3.0$

Linear guide

$$F_{y,\text{stat}} = \text{Max}[F_{y1}, F_{y2}, F_{y3}] \leq \frac{C_{0,\text{guide}}}{f_s}$$

$$F_{z,\text{stat}} = \text{Max}[F_{z1}, F_{z2}, F_{z3}] \leq \frac{C_{0,\text{guide}}}{f_s}$$

$$M_{x,\text{stat}} = \text{Max}[M_{x1}, M_{x2}, M_{x3}] \leq \frac{1}{k_x} \times \frac{C_{0,\text{guide}}}{f_s}$$

$$M_{y,\text{stat}} = \text{Max}[M_{y1}, M_{y2}, M_{y3}] \leq \frac{1}{k_y} \times \frac{C_{0,\text{guide}}}{f_s}$$

$$M_{z,\text{stat}} = \text{Max}[M_{z1}, M_{z2}, M_{z3}] \leq \frac{1}{k_z} \times \frac{C_{0,\text{guide}}}{f_s}$$

$F_{y/z,\text{stat}}$	Maximum value of the calculated force load per cycle phase	$M_{x1/2/3}, M_{y1/2/3}, M_{z1/2/3}$	Calculated torque load per cycle phase
$M_{x/y/z,\text{stat}}$	Maximum value of the calculated torque load per cycle phase	$C_{0,\text{guide}}$	
$F_{y1/2/3}, F_{z1/2/3}$	Calculated force load per cycle phase	$k_{x/y/z}$	Torque equivalence factors → page 13
		f_s	Safety factor against static overload $f_s = 1.0 \dots 3.0$

Electric slides EGSK

Technical data

FESTO

Dimensions

Download CAD data → www.festo.com

EGSK-15

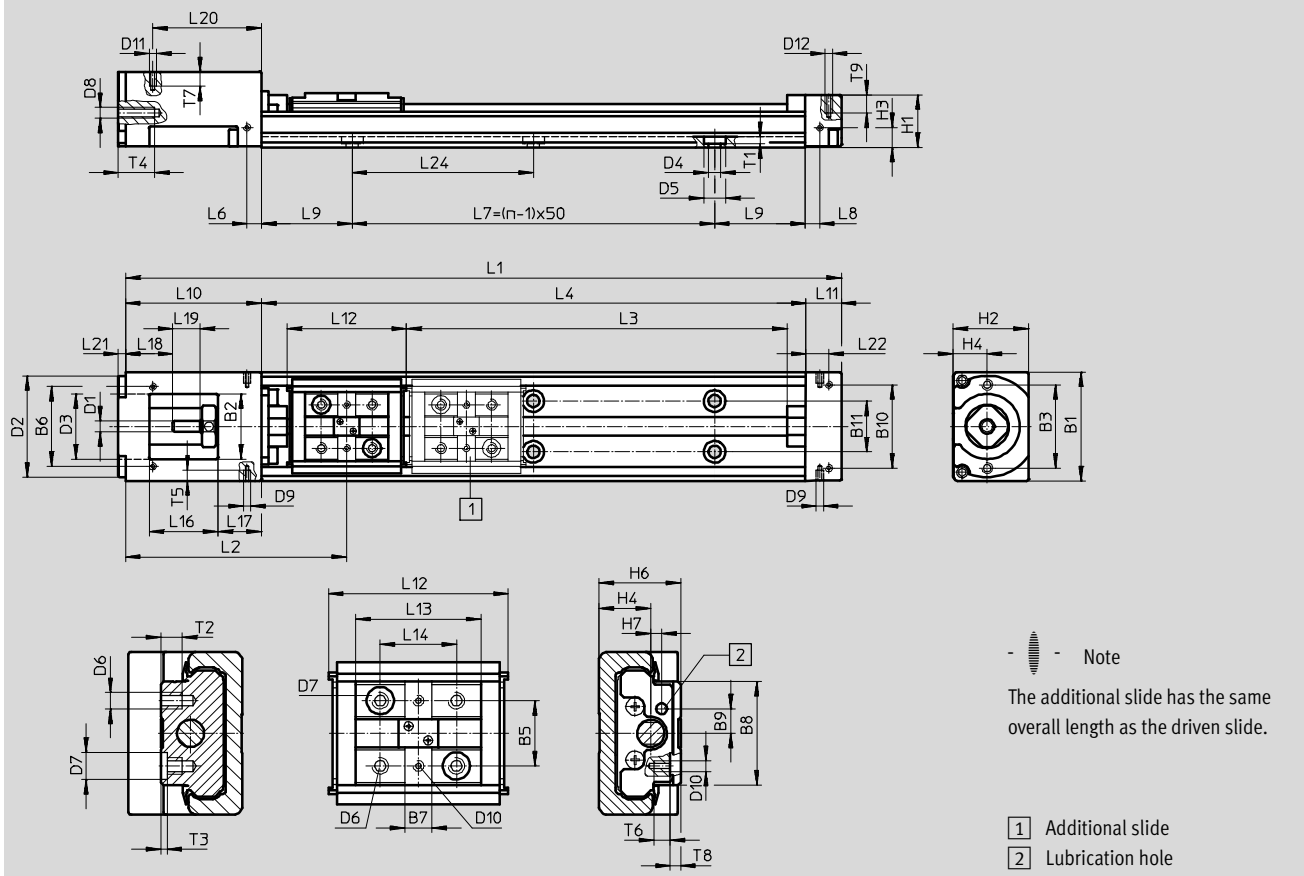

Size	Stroke	L1	L3 +4	L4	L7	L9	n
15	25	122.5	30	75	50	12.5	2
	50	147.5	55	100	50	25	2
	75	172.5	80	125	100	12.5	3
	100	197.5	105	150	100	25	3

Size	B1	B2	B3	B5	B6	B7	B8	B9	B11	B10	D1	D2	D3	D4	D5	D6	D7	D8
15	30	18	±0.1	±0.02	±0.1	5	19	4.5	14	±0.1	h6	g7	18	3.4	6	M3	5	M3

Size	D9	D10	D11	D12	H1	H2	H3	H4	H6	H7	L2	L6	L8	L10	L11	L12	L13	L14
15	M2	M2	M2	M2	14.5	20.9	5.5	9.5	15	2	60.3	4	4	37.5	10	33	23	14

Size	L16	L17	L18	L19	L20	L21	L22	L24	T1	T2	T3	T4	T5	T6	T7	T8	T9
15	19	12	13	7.5	±0.1	2	±0.1	50	2	4	+0.1	10	3	3	4	1.9	5

Electric slides EGSK

Technical data



Dimensions

Download CAD data → www.festo.com

EGSK-20/26

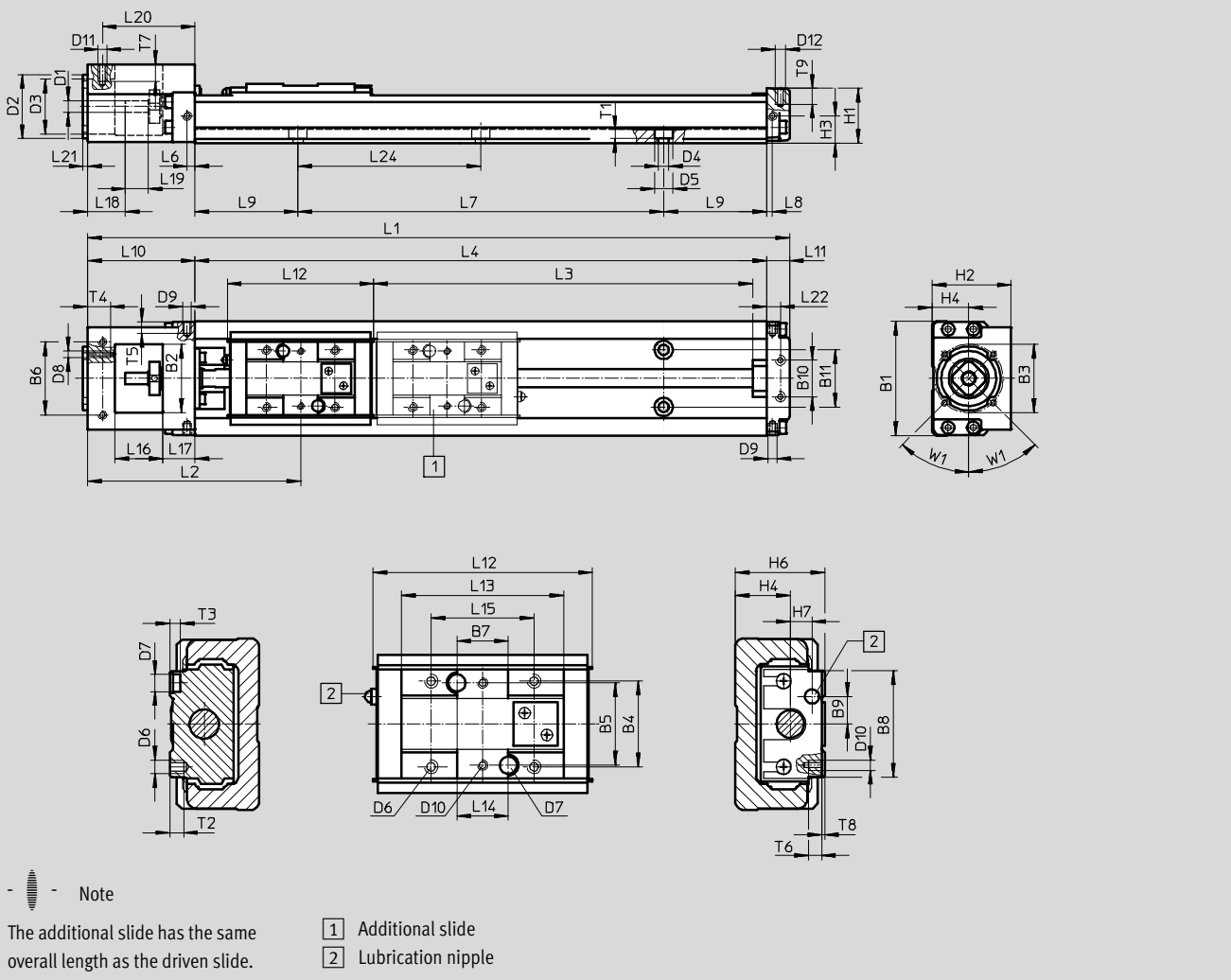

Size	Stroke	L1	L3 +4	L4	L7= (n-1)x60	L9	n
20	25	152	40	100	60	20	2
	75	202	90	150	120	15	3
	125	252	140	200	120	40	3

Size	Stroke	L1	L3 +4	L4	L7= (n-1)x80	L9	n
26	50	207	67	150	80	35	2
	100	257	117	200	160	20	3
	150	307	167	250	160	45	3
	200	357	217	300	240	30	4

Electric slides EGSK

Technical data

Size	B1	B2	B3 ∅	B4	B5 ±0.02	B6 ±0.1	B7	B8	B9	B10 ±0.1	B11	D1 ∅ h7	D2 ∅ g7	D3 ∅
20	40	22	30	18	18	29	10	23	5	18	18	4	28	22
26	50	30	30	25	24	32	15	31	8	16	25	5	28	24

Size	D4 ∅	D5 ∅	D6	D7 ∅ H7	D8	D9	D10	D11	D12	H1	H2	H3	H4	H6
20	3.4	6.5	M3	2	M3	M2.6	M2	M2.5	M2.5	19	28	10	13	20
26	4.5	8	M4	5	M3	M2.6	M3	M2.5	M3	24	34.5	12	16	26

Size	H7	L2	L6	L8	L10	L11	L12	L13	L14 ¹⁾ ±0.02	L15	L16	L17	L18	L19
20	3.4	72.5	3.5	2.5	42	10	46	33.2	10	20	18	12	16	8
26	6	91	3.5	2.5	47	10	64	47.4	15	30	21	14	16.5	10

Size	L20 ±0.1	L21	L22 ±0.1	L24	T1	T2	T3	T4	T5	T6	T7	T8	T9	W1
20	34.5	2	6.5	60	3	4.5	3	10	4	5	5	0.9	5	45°
26	40.5	2	6	80	4	6.5	3	10	4	6	5	0.9	6	45°

1) Distance between the locating holes

Electric slides EGSK

Technical data

FESTO

Dimensions

Download CAD data → www.festo.com

EGSK-33/46

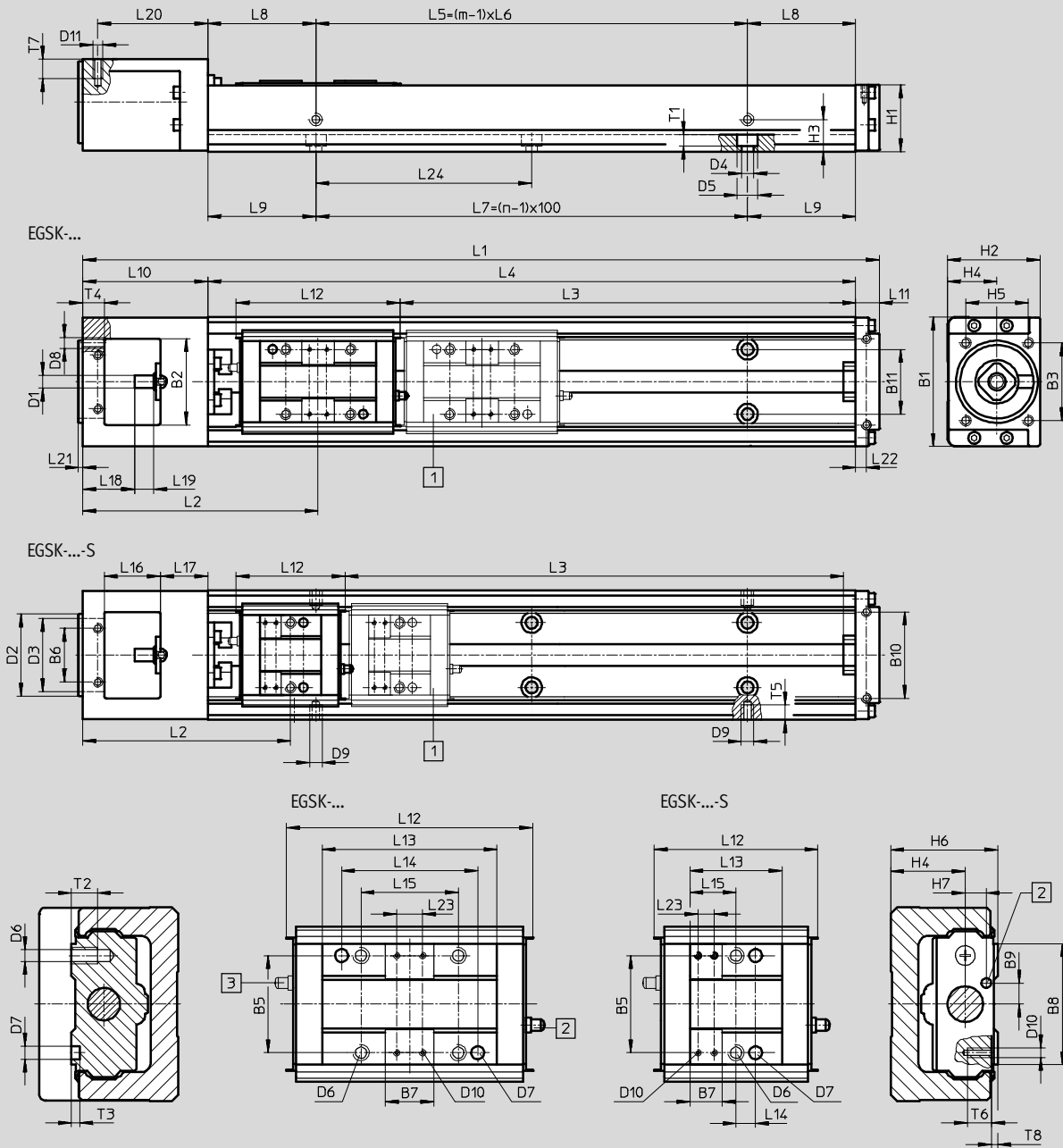

Note

The additional slide has the same overall length as the driven slide.

- 1 Additional slide
- 2 Lubrication nipple

- 3 The lubrication nipple is in the direction of the drive cover on the version with additional slide (EGSK...-Z)

Electric slides EGSK

Technical data

Size	Stroke	L1	L3 +4		L4	L5	L6	L7	L8	m	n
				S							
33	100	269	110	135	200	100	100	100	50	2	2
	200	369	210	235	300	200	200	200	50	2	3
	300	469	310	335	400	200	200	300	100	2	4
	400	569	410	435	500	400	200	400	50	3	5
	500	669	510	535	600	400	200	500	100	3	6
	600	769	610	635	700	600	200	600	50	4	7

Size	Stroke	L1	L3 +4		L4	L5	L6	L7	L8	m	n
				S							
46	200	425.5	206	244	340	200	200	200	70	2	3
	300	525.5	306	344	440	400	200	300	20	3	4
	400	625.5	406	444	540	400	200	400	70	3	5
	500	725.5	506	544	640	600	200	500	20	4	6
	600	825.5	606	644	740	600	200	600	70	4	7
	800	1025.5	806	844	940	800	200	800	70	5	9

Size	B1	B2	B3 ±0.1	B5 ±0.04	B6 ±0.1	B7	B8	B9	B10 ±0.1	B11	D1 ∅ h7	D2 ∅ g7	D3 ∅	D4 ∅	D5 ∅
33	60	40	36	30	25	15	37.4	6.5	40	30	6	38	34	5.5	9.5
46	86	48	36	46	42	15	54.4	10	58	46	8	38	34	6.6	11

Size	D6	D7 ∅ H7	D8	D9	D10	D11	H1	H2	H3	H4	H5 ±0.1	H6	H7	L2	
															S
33	M5	4	M5	M2.6	M2	M3	31	43	15	23	29	33	6.5	105	92.3
46	M6	5	M5	M2.6	M2	M4	43.5	60	28	32	29	46	9	142.5	123.8

Size	L9	L10	L11	L12		L13		L14		L15		L16	L17	L18	L19
					S		S	±0.04	±0.1		S				
33	50	58	11	76	50.5	54	28.5	42	6	30	14.25	26	22	24	9
46	70	72.5	13	110	72.5	81	43.5	28	11	46	21.75	33.5	25	21.5	18

Size	L20 ±0.1	L21	L22 ±0.1	L23		L24	T1	T2	T3	T4	T5	T6	T7	T8
					S									
33	51	2	5	8	5	100	5.4	8	2.5	10	4	5	6	1
46	65.5	2	3.5	8	8	100	6.5	12	2.5	10	4	5	8	1

Electric slides EGSK

Technical data

Ordering data – Electric slides with standard slide					
Size	Stroke [mm]	Part No.	Type	Part No.	Type
		Spindle pitch 1 mm		Spindle pitch 6 mm	
20	25	562758	EGSK-20-25-1P	562761	EGSK-20-25-6P
	75	562759	EGSK-20-75-1P	562762	EGSK-20-75-6P
	125	562760	EGSK-20-125-1P	562763	EGSK-20-125-6P

Size	Stroke [mm]	Part No.	Type	Part No.	Type
		Spindle pitch 2 mm		Spindle pitch 6 mm	
26	50	562764	EGSK-26-50-2P	562768	EGSK-26-50-6P
	100	562765	EGSK-26-100-2P	562769	EGSK-26-100-6P
	150	562766	EGSK-26-150-2P	562770	EGSK-26-150-6P
	200	562767	EGSK-26-200-2P	562771	EGSK-26-200-6P

Size	Stroke [mm]	Part No.	Type	Part No.	Type
		Spindle pitch 6 mm		Spindle pitch 10 mm	
33	100	562772	EGSK-33-100-6P	562778	EGSK-33-100-10P
	200	562773	EGSK-33-200-6P	562779	EGSK-33-200-10P
	300	562774	EGSK-33-300-6P	562780	EGSK-33-300-10P
	400	562775	EGSK-33-400-6P	562781	EGSK-33-400-10P
	500	562776	EGSK-33-500-6P	562782	EGSK-33-500-10P
	600	562777	EGSK-33-600-6P	562783	EGSK-33-600-10P

Size	Stroke [mm]	Part No.	Type	Part No.	Type
		Spindle pitch 10 mm		Spindle pitch 20 mm	
46	200	562784	EGSK-46-200-10P	562790	EGSK-46-200-20P
	300	562785	EGSK-46-300-10P	562791	EGSK-46-300-20P
	400	562786	EGSK-46-400-10P	562792	EGSK-46-400-20P
	500	562787	EGSK-46-500-10P	562793	EGSK-46-500-20P
	600	562788	EGSK-46-600-10P	562794	EGSK-46-600-20P
	800	562789	EGSK-46-800-10P	562795	EGSK-46-800-20P

Electric slides EGSK

Ordering data – Modular products



Ordering table											
Size	15	20	26	33	46	Condi- tions	Code	Enter code			
M Module No.	562749	562750	562751	562752	562753						
Drive function	Electric slide drive						EGSK	EGSK			
Size	15	20	26	33	46		-...	-...			
Standard stroke for standard slide [mm]	25	-		-			-25	-...			
	50	-	50	-			-50	-...			
	75	-		-			-75	-...			
	100	-	100	-			-100	-...			
	-	125	-		-			-125	-...		
	-	-		150	-			-150	-...		
	-	-		200	-			-200	-...		
	-	-			300	-			-300	-...	
	-	-			400	-			-400	-...	
	-	-			500	-			-500	-...	
	-	-			600	-			-600	-...	
	-	-				800	-			-800	-...
	Standard stroke for slide, short [mm]	-			130	-			-130	-...	
-			230	-			-230	-...			
-				240	-			-240	-...		
-				330	-			-330	-...		
-				340	-			-340	-...		
-				430	-			-430	-...		
-				440	-			-440	-...		
-				530	-			-530	-...		
-				540	-			-540	-...		
-				630	-			-630	-...		
-				640	-			-640	-...		
Spindle pitch [mm]	1		-		-			-1P	-...		
	2	-	2	-			-2P	-...			
	-		6	-			-6P	-...			
	-			10	-			-10P	-...		
	-				20	-			-20P	-...	
O Accuracy	-		Standard accuracy				-	-			
	Greater accuracy						-H	-			
	Precision accuracy					1	-P	-			
Slide design	Standard slide						-	-			
	-			Slide, short			-S	-			
Additional slide	No additional slide						-	-			
	Additional slide (additional slide Z in combination with slide design S also results in a short slide)					2	-Z	-			

- 1 P** With size 33 not in combination with stroke for standard slide 600 and stroke for slide, short 630
With size 46 not in combination with stroke for standard slide 800 and stroke for slide, short 840
- 2 Z** With size 15 not in combination with stroke for standard slide 25 and stroke for standard slide 50
With size 20 not in combination with stroke for standard slide 25
With size 26 not in combination with stroke for standard slide 50
With size 33 not in combination with stroke for standard slide 100

Transfer order code

Electric slides EGSP

Type codes

		EGSP	-	26	-	150	-	2P	-	H	-		-	Z
Type														
EGSP	Electric slide													
Size														
Stroke [mm]														
Spindle pitch														
Accuracy														
-	Standard													
H	High accuracy													
P	Precision design													
Slide design														
-	Standard slide													
S	Slide, short													
Additional slide														
-	No additional slide													
Z	Additional slide													



Electric slides EGSP

Technical data

FESTO

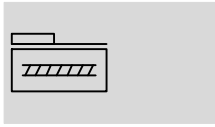
Function



-  Size
20 ... 46
-  Stroke length
25 ... 840 mm



General technical data										
Size		20		26		33			46	
Spindle pitch		1	6	2	6	6	10	20	10	20
	Code ¹⁾									
Constructional design		Electromechanical linear axis with recirculating ball bearing spindle								
Guide		Recirculating ball bearing guide								
Installation position		Any								
Type of mounting for effective load		Female thread Locating pin								
Working stroke ²⁾	- [mm]	25 ... 125		50 ... 200		100 ... 600			200 ... 800	
	S [mm]	-		-		130 ... 630			240 ... 840	
Max. feed force	-/H ³⁾ [N]	69	72	168	164	370	227	165	365	267
F _{x,max}	P ⁴⁾ [N]	87	112	212	212	466	286	208	460	337
Max. driving torque	-/H ³⁾ [Ncm]	1.1	6.9	5.3	16	35	36	53	58	85
M _{Driving,max}	P ⁴⁾ [Ncm]	1.4	11	6.7	20	45	46	66	73	107
No-load torque	-/H [Ncm]	0.5	0.5	1.5	1.5	7	7	7	10	10
M _{No-load}	P [Ncm]	1.2	1.2	4.0	4.0	15	15	15	17	17
Max. rotational speed ⁵⁾	[1/min]	6000	6000	6000	6000	6000	6000	6000	6000	6000
Max. speed ⁵⁾	-/H [m/s]	0.1	0.6	0.2	0.6	0.6	1	2	1	2
	P [m/s]	0.1	0.6	0.2	0.6	0.6	1	2	1	2
Max. acceleration	[m/s ²]	10		10		20			20	
Homing		Inductive proximity sensor SIES-8M								

- 1) Variant code → page 24
- 2) Maximum travel distance → page 33
In combination with an additional slide, the working stroke is reduced by the length of the additional slide and the distance between the two slides
- 3) Loads are based on a service life specification of 5×10^8 rotations
- 4) Loads are based on a service life specification of 2.5×10^8 rotations
- 5) Reduced speeds with sizes 33 and 46 with long strokes → page 27

Operating and environmental conditions		
Ambient temperature	[°C]	0 ... +40
Relative air humidity	[%]	0 ... 95 (non-condensing)

Weight [kg]									
Size		20		26		33		46	
	Code ¹⁾								
Basic weight with 0 mm stroke ²⁾	-	0.38		0.78		1.38		3.60	
	S	-		-		1.30		3.30	
Additional weight per 100 mm stroke	-	0.27		0.42		0.72		1.40	
Moving load	-	0.07		0.15		0.31		0.91	
	S	-		-		0.17		0.57	
Additional slide Z	-	0.07		0.15		0.31		0.91	
	S	-		-		0.17		0.57	

- 1) Variant code → page 24
- 2) Including slide, without additional slide

Electric slides EGSP

Technical data

FESTO

Accuracy data [µm]			20	26	33	46
Size	Stroke	Code ¹⁾				
Repetition accuracy ²⁾		–	±10	±10	±10	±10
		H	±5	±5	±5	±5
		P	±3	±3	±3	±3
Running parallelism	25 ... 340	H	25	25	25	35
	400 ... 540	H	–	–	35	35
	600 ... 640	H	–	–	40	40
	800 ... 840	H	–	–	–	50
	25 ... 340	P	10	10	10	15
	400 ... 540	P	–	–	15	15
	600 ... 640	P	–	–	20	20
Max. reversing play		–	20	20	20	20
		H	10	10	20	20
		P	3	3	3	3

1) Variant code → page 24

2) The repetition accuracy that can be achieved with a motor/axis system is also influenced by the angle resolution of the motor and the chosen control parameters. The specified repetition accuracy cannot, therefore, be achieved with all motors.

Materials

Sectional view

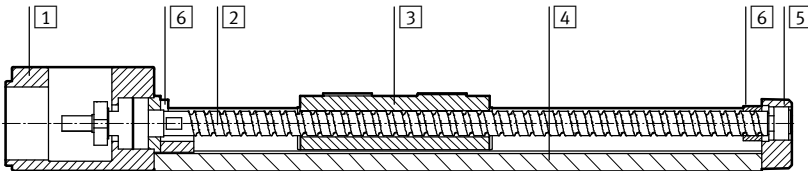

Electric slide		
1	Drive cover	Die-cast aluminium, coated
2	Spindle	Steel
3	Slide	Steel
4	Profile	High-alloy steel
5	End cap	Die-cast aluminium, coated
6	Buffer	Ethylene vinyl acetate copolymer
Note on materials		RoHS-compliant Contains PWIS (paint-wetting impairment substances)

Mass moment of inertia										
Size		20	26	33	46					
Spindle pitch		1	6	2	6	6	10	20	10	20
	Code ¹⁾									
J ₀	[kg mm ²]	0.087	0.144	0.357	0.481	2.73	3.23	5.59	8.55	15.46
	S [kg mm ²]	–	–	–	–	1.94	2.22	–	6.13	10.46
J _S per 100 mm stroke	[kg mm ² /100 mm]	0.100		0.316		2.201			3.902	
J _L per kg effective load	[kg mm ² /kg]	0.03	0.91	0.10	0.91	0.91	2.53	10.13	2.53	10.13
J _W per additional slide	[kg mm ²]	0.002	0.058	0.016	0.14	0.28	0.79	3.14	2.31	9.22
	S [kg mm ²]	–	–	–	–	0.16	0.43	–	1.44	5.78

1) Variant code → page 24

The mass moment of inertia J_A of the entire axis is calculated as follows:

$$J_A = J_0 + J_W + J_S \times \text{working stroke} + J_L \times m_{\text{effective load}}$$

Electric slides EGSP

Technical data

Speed v, rotational speed n as a function of working stroke l

EGSP-33-...-6P

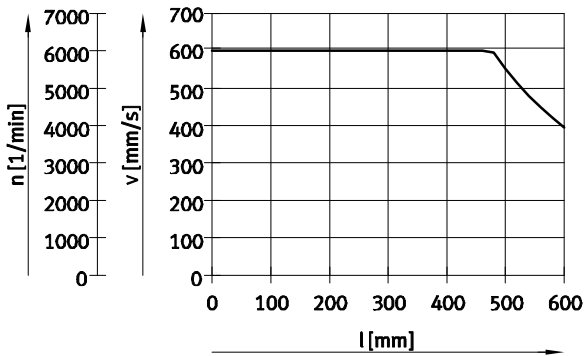

EGSP-33-...-10P

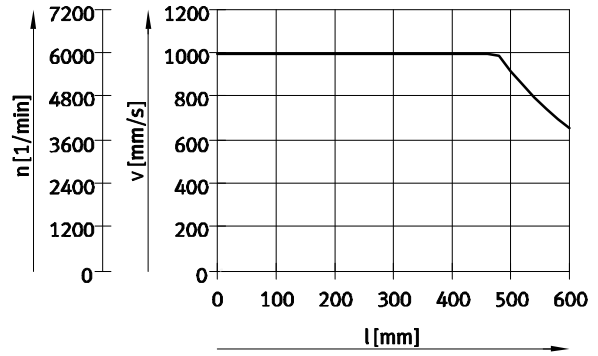

EGSP-33-...-20P

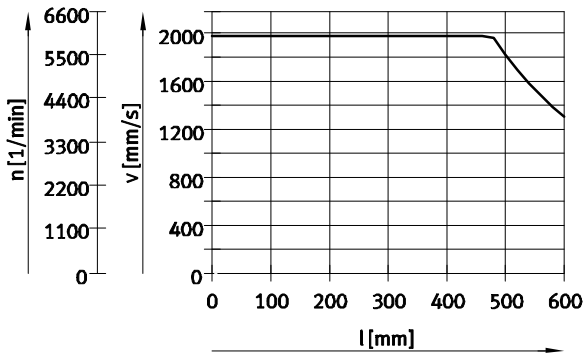

EGSP-46-...-10P

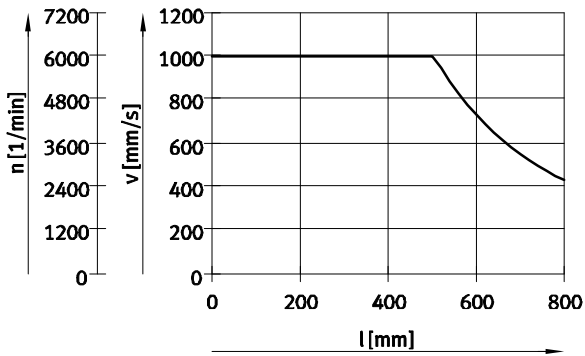

EGSP-46-...-20P

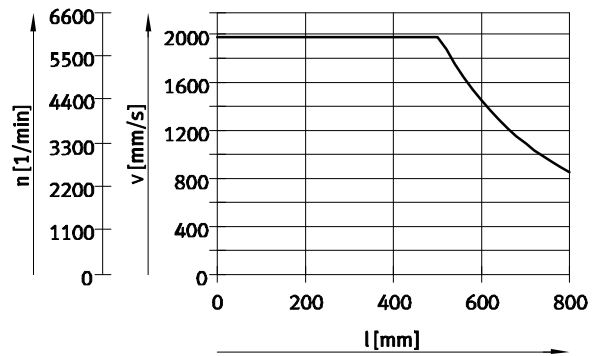

2nd moment of area

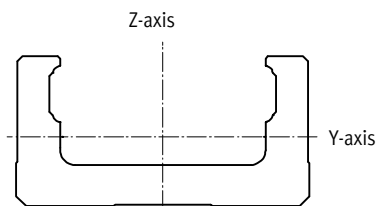

Size		20	26	33	46
ly	[mm ⁴]	6000	16600	53500	205000
lz	[mm ⁴]	61400	148000	352000	1450000

Electric slides EGSP

Technical data

Characteristic load values

The indicated forces and torques refer to the centre axis of the spindle.

The coordinate zero point is the point where the centre of the guide and the longitudinal centre of the slide intersect.

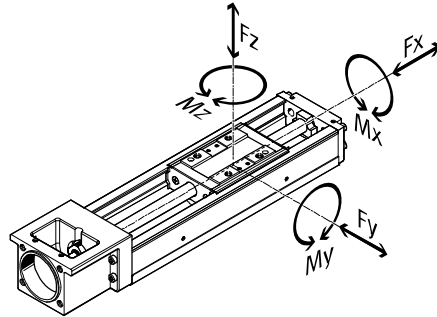

Note
PositioningDrives
sizing software
www.festo.com

Permissible dynamic forces and torques¹⁾

Size			20		26		33			46	
Spindle pitch			1	6	2	6	6	10	20	10	20
	Code ²⁾										
F _y max., F _z max.	-/H ³⁾	- [N]	2325	1279	3991	2767	3619	3052	2422	7092	5629
	P ⁴⁾	- [N]	2929	1612	5028	3486	4559	3845	3052	8935	7092
	-/H ³⁾	S [N]	-	-	-	-	2405	2029	-	5099	4047
	P ⁴⁾	S [N]	-	-	-	-	3031	2556	-	6424	5099
M _x max.	-/H ³⁾	- [Nm]	28.8	15.9	64.7	44.8	71.7	60.4	48.0	205	163
	P ⁴⁾	- [Nm]	36.3	20.0	81.5	56.5	90.3	76.1	60.4	258	205
	-/H ³⁾	S [Nm]	-	-	-	-	47.6	40.2	-	147	117
	P ⁴⁾	S [Nm]	-	-	-	-	60.0	50.6	-	186	147
M _y max., M _z max.	-/H ³⁾	- [Nm]	9.9	5.5	25.1	17.4	25.5	21.5	17.1	74.6	59.2
	P ⁴⁾	- [Nm]	12.5	6.9	31.6	21.9	32.1	27.1	21.5	94.0	74.6
	-/H ³⁾	S [Nm]	-	-	-	-	10.1	8.5	-	34.9	27.7
	P ⁴⁾	S [Nm]	-	-	-	-	12.7	10.7	-	44.0	34.9

- 1) Calculated with a speed-dependent load factor f_w of 1.2
- 2) Variant code → page 24
- 3) Loads are based on a service life specification of 5×10^8 rotations and a load factor f_w of 1.2
- 4) Loads are based on a service life specification of 2.5×10^8 rotations and a load factor f_w of 1.2

Basic load ratings

Size			20		26		33			46	
Spindle pitch			1	6	2	6	6	10	20	10	20
	Code ¹⁾										
Ball screw											
Static $C_{0\text{ball screw}}$	-/H	[N]	1170	1450	4020	3510	6290	3780	3770	6990	7040
	P	[N]	1170	1600	4020	3900	6290	3780	3770	6990	7040
Dynamic $c_{\text{dyn}\text{ball screw}}$	-/H ²⁾	[N]	660	860	2350	1950	4400	2700	2620	4350	4240
	P ²⁾	[N]	660	1060	2350	2390	4400	2700	2620	4350	4240
Fixed bearing											
Static $C_{0\text{bearing}}$		[N]	735		1230		2700			3330	
Dynamic $c_{\text{dyn}\text{bearing}}$ ²⁾		[N]	1150		2000		6250			6700	

- 1) Variant code → page 24
- 2) Dynamic basic load ratings are based on a basic service life of 10^6 rotations

Electric slides EGSP

Technical data

FESTO

Basic load ratings											
Size			20		26		33			46	
Spindle pitch			1	6	2	6	6	10	20	10	20
Code ¹⁾											
Linear guide											
Static $C_{0,guide}$	-	[N]	8030		16500		20400			45900	
	S	[N]	-		-		11500			-	
Dynamic $C_{dyn,guide}$ ²⁾	-	[N]	4770		10318		13493			31351	
	S	[N]	-		-		8969			-	
Torque equivalence factors											
k_x	-	[1/m]	80.7		61.7		50.5			34.6	
	S	[1/m]	-		-		50.5			-	
k_y, k_z	-	[1/m]	234.4		159.1		142			95.1	
	S	[1/m]	-		-		239.1			-	

1) Variant code → page 24

2) Dynamic basic load ratings are based on a basic service life of 100 km

Speed-dependent load factor f_w

$f_w = 1.0 \dots 1.2$ ($v \leq 0.25$ m/s)

$f_w = 1.2 \dots 1.5$ (0.25 m/s $\leq v \leq 1.0$ m/s)

$f_w = 1.5 \dots 2.0$ (1.0 m/s $\leq v \leq 2.0$ m/s)

$f_w = 2.0 \dots 3.5$ ($v \geq 2.0$ m/s)

Calculation of the maximum feed force F_x

$$F_{x,max} = \frac{1}{f_w} \times \frac{\text{Min}[C_{dyn,KGT}; C_{dyn,bearing}]}{\sqrt[3]{\frac{L_{ref,rot}}{10^6}}}$$

Calculation of the maximum forces $F_{y/z}$ and torques $M_{x/y/z}$

$$F_{y/z,max} = \frac{1}{f_w} \times \frac{C_{dyn,guide}}{\sqrt[3]{\frac{L_{ref,km}}{100km}}}$$

$$M_{x/y/z,max} = \frac{1}{k_{x/y/z}} \times \frac{1}{f_w} \times \frac{C_{dyn,guide}}{\sqrt[3]{\frac{L_{ref,km}}{100km}}}$$

Electric slides EGSP

Technical data



Calculation of the service life										
Size	20			26		33			46	
Spindle pitch P	1	6		2	6	6	10	20	10	20
	Code ¹⁾									
Reference service life	-/H	5 x 10 ⁸								
in rotations, L _{ref,rot}	P	2.5 x 10 ⁸								
Reference service life	-/H [km]	500	3000	1000	3000	3000	5000	10000	5000	10000
in kilometres, L _{ref,km}	P [km]	250	1500	500	1500	1500	2500	5000	2500	5000

1) Variant code → page 24

1 Representation of the loads

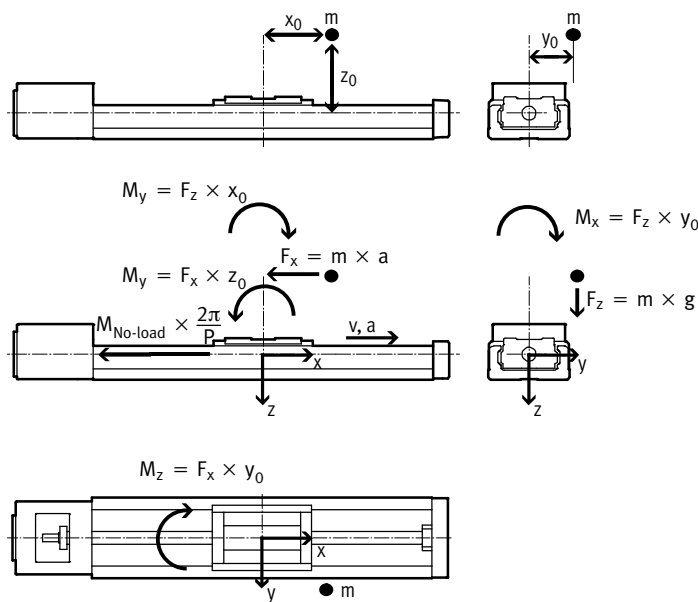

2 Determination of the loads over the travel cycle

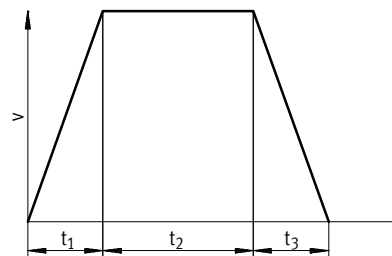

$$q_1 = \frac{t_1}{t_{tot}} \quad q_2 = \frac{t_2}{t_{tot}} \quad q_3 = \frac{t_3}{t_{tot}}$$

$$t_{tot} = t_1 + t_2 + t_3$$

v	Speed
t ₁	Acceleration time
t ₂	Constant travel time
t ₃	Deceleration time
q _{1/2/3}	Relative time of the cycle phases
t _{tot}	Cycle time

Ball screw

For t₁: $F_{x1} = - (m \times a) - (M_{No-load} \times \frac{2\pi}{P})$

For t₂: $F_{x2} = - (M_{No-load} \times \frac{2\pi}{P})$

For t₃: $F_{x3} = m \times a - (M_{No-load} \times \frac{2\pi}{P})$

F _{x1/2/3}	Calculated force load per cycle phase
F _{x,dyn}	Calculated average force load
m	Effective load (centre of gravity)
a	Acceleration
M _{No-load}	No-load torque → page 25
P	Spindle pitch → page 25
q _{1/2/3}	Relative time of the cycle phases

$$F_{x,dyn} = \sqrt[3]{q_1 \times |F_{x1}|^3 + q_2 \times |F_{x2}|^3 + q_3 \times |F_{x3}|^3}$$

2 Determination of the loads over the travel cycle
Linear guide

<p>For t₁: a →, v →</p> <p>$F_{y1} = 0$</p> <p>$F_{z1} = m \times g$</p> <p>$M_{x1} = F_z \times y_0 = m \times g \times y_0$</p> <p>$M_{y1} = -F_z \times x_0 + F_x \times z_0 = -m \times g \times x_0 + m \times a \times z_0$</p> <p>$M_{z1} = F_x \times y_0 = m \times a \times y_0$</p> <p>For t₂: a = 0, v →</p> <p>$F_{y2} = 0$</p> <p>$F_{z2} = m \times g$</p> <p>$M_{x2} = F_z \times y_0 = m \times g \times y_0$</p> <p>$M_{y2} = -F_z \times x_0 = -m \times g \times x_0$</p> <p>$M_{z2} = 0$</p> <p>For t₃: a ←, v →</p> <p>$F_{y3} = 0$</p> <p>$F_{z3} = m \times g$</p> <p>$M_{x3} = F_z \times y_0 = m \times g \times y_0$</p> <p>$M_{y3} = -F_z \times x_0 - F_x \times z_0 = -m \times g \times x_0 - m \times a \times z_0$</p> <p>$M_{z3} = -F_x \times y_0 = -m \times a \times y_0$</p>	<p>$F_{y1/2/3}$, $F_{z1/2/3}$</p> <p>$M_{x1/2/3}$, $M_{y1/2/3}$, $M_{z1/2/3}$</p> <p>$F_{y/z,dyn}$</p> <p>$M_{x/y/z,dyn}$</p> <p>m</p> <p>g</p> <p>a</p> <p>x_0, y_0, z_0</p> <p>$q_{1/2/3}$</p>	<p>Calculated force load per cycle phase</p> <p>Calculated torque load per cycle phase</p> <p>Calculated average force load</p> <p>Calculated average torque load</p> <p>Effective load (centre of gravity)</p> <p>Gravitational acceleration</p> <p>Acceleration</p> <p>Distances between the centre of gravity of the effective load and the slide centre point</p> <p>Relative time of the cycle phases</p>
---	--	--

$$F_{y,dyn} = \sqrt[3]{q_1 \times |F_{y1}|^3 + q_2 \times |F_{y2}|^3 + q_3 \times |F_{y3}|^3}$$

$$F_{z,dyn} = \sqrt[3]{q_1 \times |F_{z1}|^3 + q_2 \times |F_{z2}|^3 + q_3 \times |F_{z3}|^3}$$

$$M_{x,dyn} = \sqrt[3]{q_1 \times |M_{x1}|^3 + q_2 \times |M_{x2}|^3 + q_3 \times |M_{x3}|^3}$$

$$M_{y,dyn} = \sqrt[3]{q_1 \times |M_{y1}|^3 + q_2 \times |M_{y2}|^3 + q_3 \times |M_{y3}|^3}$$

$$M_{z,dyn} = \sqrt[3]{q_1 \times |M_{z1}|^3 + q_2 \times |M_{z2}|^3 + q_3 \times |M_{z3}|^3}$$

3 Total load
Ball screw

<p>$\frac{ F_{x,dyn} }{F_{x,max}} \leq f_v$</p>	<p>$F_{x,dyn}$</p> <p>$F_{x,max}$</p> <p>f_v</p>	<p>Calculated average force load</p> <p>Max. permissible force load → page 25</p> <p>Load comparison factor → page 32</p>
--	---	---

Linear guide

<p>$\frac{ F_{y,dyn} }{F_{y,max}} + \frac{ F_{z,dyn} }{F_{z,max}} + \frac{ M_{x,dyn} }{M_{x,max}} + \frac{ M_{y,dyn} }{M_{y,max}} + \frac{ M_{z,dyn} }{M_{z,max}} \leq f_v$</p>	<p>$F_{y/z,dyn}$</p> <p>$F_{y/z,max}$</p> <p>$M_{x/y/z,dyn}$</p> <p>$M_{x/y/z,max}$</p> <p>f_v</p>	<p>Calculated average force load</p> <p>Max. permissible force load → page 28</p> <p>Calculated average torque load</p> <p>Max. permissible torque load → page 28</p> <p>Load comparison factor → page 32</p>
--	---	---

Electric slides EGSP

Technical data

4 Determination of the load comparison factor f_v

$$f_v = \frac{1}{\sqrt[3]{q}} \quad \text{with} \quad q = \frac{L_{\text{calc,km}}}{L_{\text{ref,km}}} = \frac{L_{\text{calc,rot}}}{L_{\text{ref,rot}}}$$

for $q = 1$:

Calculated service life (here desired service life) $L_{\text{calc,km}} = 1 \times$ reference service life $L_{\text{ref,km}}$ gives $f_v = 1$

for $q \neq 1$:

Calculated service life (here desired service life) $L_{\text{calc,km}} = q \times$ reference service life $L_{\text{ref,km}}$ read off (→ graph) or calculate f_v

f_v	Load comparison factor
q	Quotient of desired service life divided by reference service life
$L_{\text{calc, km}}$	Calculated service life in km
$L_{\text{ref, km}}$	Reference service life in km → page 30
$L_{\text{calc, rot}}$	Calculated service life in rotations
$L_{\text{ref, rot}}$	Reference service life in rotations → page 30

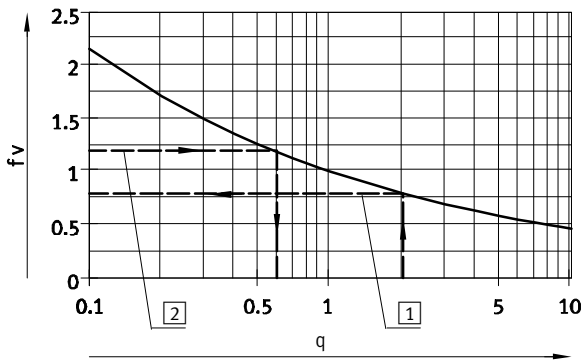

- 1 → Example 1
- 2 → Example 2

5 Calculation examples

Example 1:

EGSP-26-...-2P-H-...

$L_{\text{ref,km}} = 1000 \text{ km}$

$L_{\text{calc,km}} = 2000 \text{ km}$

$$q = \frac{2000\text{km}}{1000\text{km}} = 2.0$$

$$f_v = \frac{1}{\sqrt[3]{q}} = 0.79$$

Result:

A desired service life of 200% of the reference service life means that the permissible total load must be 21% lower.

Example 2:

If the total load calculation gives a load comparison factor f_v of 1.2, the mathematical service life is only approx. 60% ($x = 0.6$ → graph) of the reference service life.

$$q = \frac{1}{f_v^3} = 0.58$$

6 Static sizing

Ball screw

$$F_{x,\text{stat}} = \text{Max}[F_{x1}, F_{x2}, F_{x3}] \leq \frac{C_{0,\text{KGT}}}{f_s}$$

$F_{x,\text{stat}}$	Maximum value of the calculated force load per cycle phase	$C_{0,\text{KGT}}$	Static basic load rating of ball screw → page 28
$F_{x1/2/3}$	Calculated force load per cycle phase	f_s	Safety factor against static overload $f_s = 1.0 \dots 3.0$

Linear guide

$$F_{y,\text{stat}} = \text{Max}[F_{y1}, F_{y2}, F_{y3}] \leq \frac{C_{0,\text{guide}}}{f_s}$$

$$F_{z,\text{stat}} = \text{Max}[F_{z1}, F_{z2}, F_{z3}] \leq \frac{C_{0,\text{guide}}}{f_s}$$

$$M_{x,\text{stat}} = \text{Max}[M_{x1}, M_{x2}, M_{x3}] \leq \frac{1}{k_x} \times \frac{C_{0,\text{guide}}}{f_s}$$

$$M_{y,\text{stat}} = \text{Max}[M_{y1}, M_{y2}, M_{y3}] \leq \frac{1}{k_y} \times \frac{C_{0,\text{guide}}}{f_s}$$

$$M_{z,\text{stat}} = \text{Max}[M_{z1}, M_{z2}, M_{z3}] \leq \frac{1}{k_z} \times \frac{C_{0,\text{guide}}}{f_s}$$

$F_{y/z,\text{stat}}$	Maximum value of the calculated force load per cycle phase	$M_{x1/2/3}, M_{y1/2/3}, M_{z1/2/3}$	Calculated torque load per cycle phase
$M_{x/y/z,\text{stat}}$	Maximum value of the calculated torque load per cycle phase	$C_{0,\text{guide}}$	
$F_{y1/2/3}, F_{z1/2/3}$	Calculated force load per cycle phase	$k_{x/y/z}$	Torque equivalence factors → page 29
f_s	Safety factor against static overload	$f_s = 1.0 \dots 3.0$	Safety factor against static overload

Electric slides EGSP

Technical data



Dimensions

Download CAD data → www.festo.com

EGSP-20/26

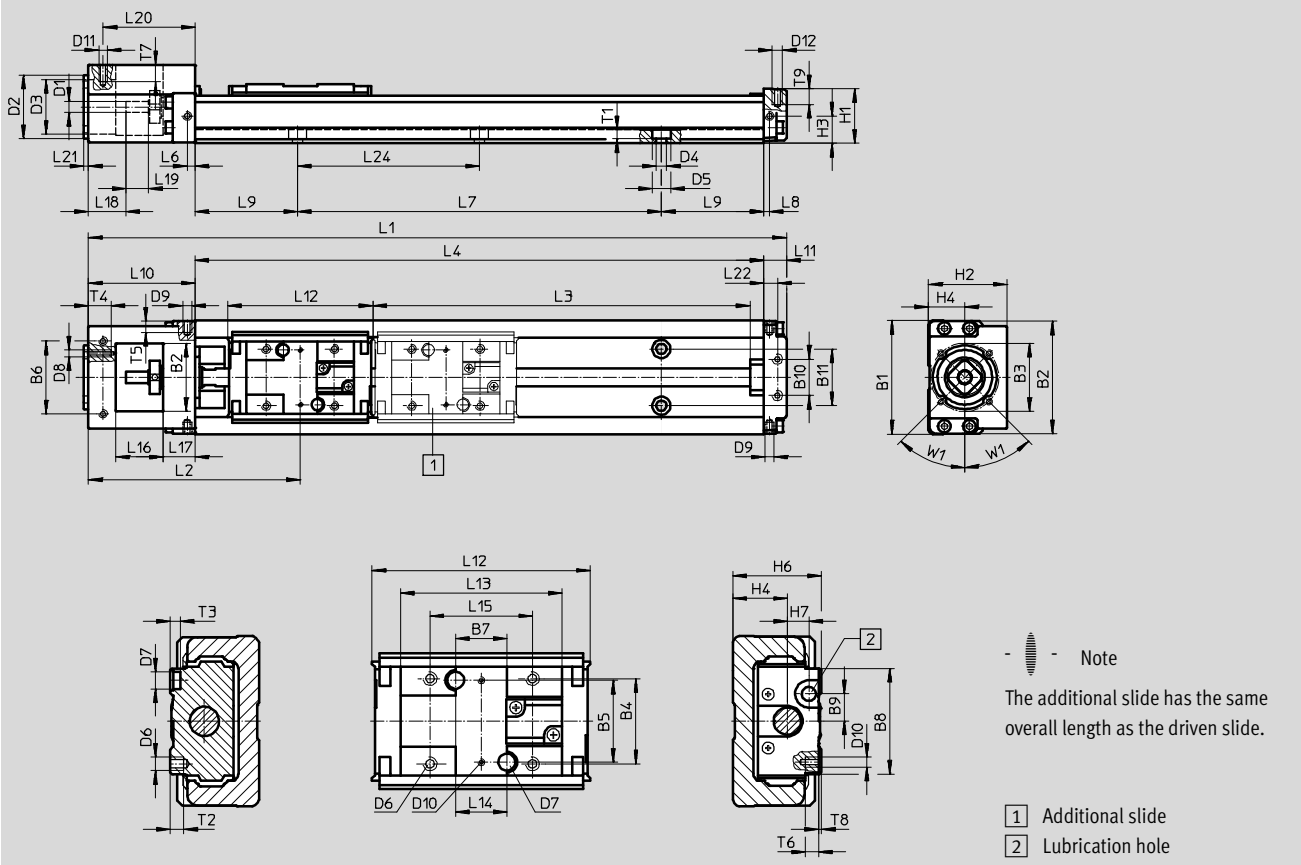

Size	Stroke	L1	L3 +4	L4	L7= (n-1)x60	L9	n	Size	Stroke	L1	L3 +4	L4	L7= (n-1)x80	L9	n
20	25	152	39	100	60	20	2	26	50	207	67	150	80	35	2
	75	202	89	150	120	15	3		100	257	117	200	160	20	3
	125	252	139	200	120	40	3		150	307	167	250	160	45	3
									200	357	217	300	240	30	4

Size	B1	B2	B3 ∅	B4	B5 ±0.02	B6 ±0.1	B7	B8	B9	B10 ±0.1	B11	D1 ∅	D2 ∅	D3 ∅	D4 ∅	D5 ∅	D6	D7 ∅	D8
20	40	22	30	18	18	29	10	23	5.5	18	18	4	28	22	3.4	6.5	M3	2	M3
26	50	30	30	25	24	32	15	31	8	16	25	5	28	24	4.5	8	M4	5	M3

Size	D9	D10	D11	D12	H1	H2	H3	H4	H6	H7	L2	L6	L8	L10	L11	L12	L13	L14 ¹⁾
																		±0.02
20	M2.6	M1.6	M2.5	M2.5	19	28	10	13	20	4	72.8	3.5	2.5	42	10	46	33.2	10
26	M2.6	M2	M2.5	M3	24	34.5	12	16	26	6.3	91.3	3.5	2.5	47	10	64	47.4	15

Size	L15	L16	L17	L18	L19	L20 ±0.1	L21 ±0.1	L22	L24	T1	T2	T3	T4	T5	T6	T7	T8	T9	W1
20	20	18	12	16	8	34.5	2	6.5	60	3	3	3	10	4	2.4	5	0.9	5	45°
26	30	21	14	16.5	10	40.5	2	6	80	4	4	3	10	4	3	5	0.9	6	45°

1) Distance between the locating holes

Electric slides EGSP

Technical data



Dimensions

Download CAD data → www.festo.com

EGSP-33/46

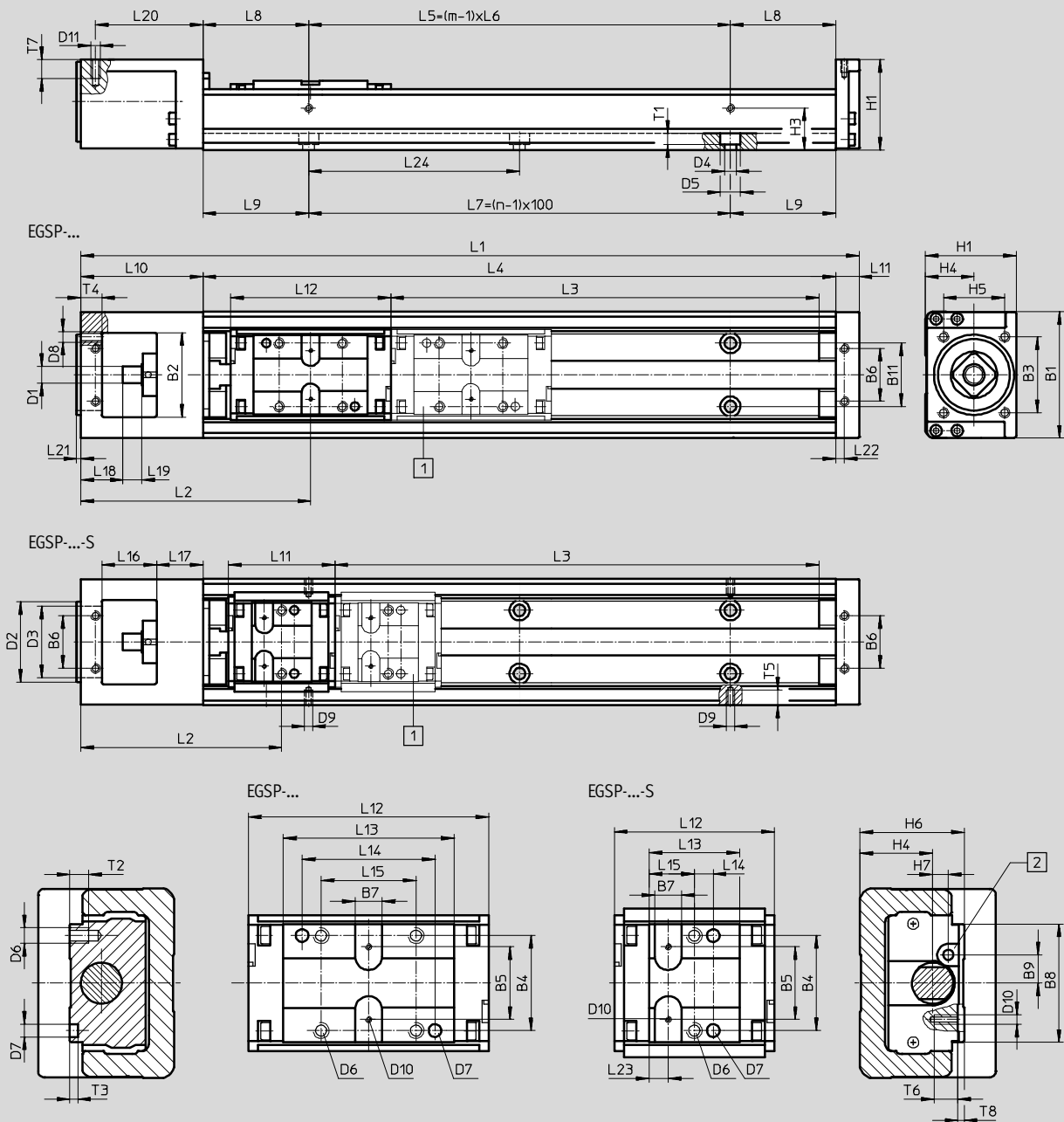

Note

The additional slide has the same overall length as the driven slide.

- 1 Additional slide
- 2 Lubrication hole

Electric slides EGSP

Technical data

FESTO

Size	Stroke	L1	L3 +4		L4	L5	L6	L7	L8	m	n
				S							
33	100	269	103	130	200	100	100	100	50	2	2
	200	369	203	230	300	200	200	200	50	2	3
	300	469	303	330	400	200	200	300	100	2	4
	400	569	403	430	500	400	200	400	50	3	5
	500	669	503	530	600	400	200	500	100	3	6
	600	769	603	630	700	600	200	600	50	4	7

Size	Stroke	L1	L3 +4		L4	L5	L6	L7	L8	m	n
				S							
46	200	425.5	206	240	340	200	200	200	70	2	3
	300	525.5	306	340	440	400	200	300	20	3	4
	400	625.5	406	440	540	400	200	400	70	3	5
	500	725.5	506	540	640	600	200	500	20	4	6
	600	825.5	606	640	740	600	200	600	70	4	7
	800	1025.5	806	840	940	800	200	800	70	5	9

Size	B1	B2	B3 ±0.1	B4	B5 ±0.04	B6 ±0.1	B7	B8	B9	B10	B11	D1 ∅ h7	D2 ∅ g7	D3 ∅	D4 ∅
33	60	40	36	30	30	25	8.5	37.4	8.9	23	30	8	38	34	5.5
46	86	48	36	46	46	42	10	54.4	10	46	46	10	38	34	6.6

Size	D5 ∅	D6	D7 ∅ H7	D8	D9	D10	D11	H1	H3	H4	H5 ±0.1	H6	H7	L2	
															S
33	9.5	M5	4	M5	M2.6	M2	M3	43	20	23	29	33	5	107	94.3
46	11	M6	5	M5	M2.6	M2	M4	60	29	32	29	46	8	140	123.5

Size	L9	L10	L11	L12		L13		L14		L15		L16	L17	L18	L19
					S		S	±0.04	±0.1		S				
33	50	58	11	76	50.5	54	28.5	42	6	30	14.25	26	22	20	9
46	70	72.5	13	110	77	81	48	28	11	46	24	33.5	25	19.5	18

Size	L20 ±0.1	L21	L22 ±0.1	L24	T1	T2	T3	T4	T5	T6	T7	T8
33	51	2	4	100	5.4	6	2.5	10	3.5	5	6	2
46	65.5	2	6	100	6.5	9	2.5	10	4	5	8	2

Electric slides EGSP

Ordering data – Modular products



Ordering table							
Size	20	26	33	46	Condi- tions	Code	Enter code
M Module No.	562754	562755	562756	562757			
Drive function	Electric slide drive, with caged balls					EGSP	EGSP
Size	20	26	33	46		-...	-...
Standard stroke for standard slide [mm]	25	-	-	-		-25	-...
	-	50	-	-		-50	-...
	75	-	-	-		-75	-...
	-	100	-	-		-100	-...
	125	-	-	-		-125	-...
	-	150	-	-		-150	-...
	-	200	-	-		-200	-...
	-	-	300	-		-300	-...
	-	-	400	-		-400	-...
	-	-	500	-		-500	-...
-	-	600	-		-600	-...	
-	-	-	800		-800	-...	
Standard stroke for slide, short [mm]	-	-	130	-		-130	-...
	-	-	230	-		-230	-...
	-	-	-	240		-240	-...
	-	-	330	-		-330	-...
	-	-	-	340		-340	-...
	-	-	430	-		-430	-...
	-	-	-	440		-440	-...
	-	-	530	-		-530	-...
	-	-	-	540		-540	-...
	-	-	630	-		-630	-...
-	-	-	640		-640	-...	
-	-	-	840		-840	-...	
Spindle pitch [mm]	1	-	-	-		-1P	-...
	-	2	-	-		-2P	-...
	6	-	-	-		-6P	-...
	-	-	10	-		-10P	-...
	20	-	20	-		-20P	-...
O Accuracy	Standard accuracy						
	Greater accuracy						-H
	Precision accuracy					1	-P
Slide design	Standard slide						-
	-			Slide, short		2	-S
Additional slide	No additional slide						-
	Additional slide (additional slide Z in combination with slide design S also results in a short slide)					3	-Z



- 1** P With size 46 not in combination with stroke for standard slide 800 and stroke for slide, short 840
- 2** S With size 33 not in combination with spindle pitch 20
- 3** Z With size 20 not in combination with stroke for standard slide 25
With size 26 not in combination with stroke for standard slide 50
With size 33 not in combination with stroke for standard slide 100

Transfer order code

EGSP - - - - - - -

Electric slides EGSK/EGSP

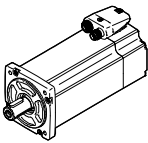
Accessories

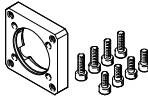
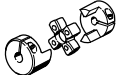
Permissible axis/motor combinations with axial kit – Without gear unit			Technical data → Internet: eamm-a
Motor	Axial kit	Axial kit consisting of:	
		Motor flange	Coupling
			
Type	Part No. Type	Part No. Type	Part No. Type
EGSK-15			
With servo motor			
EMME-AS-40-...	1982886 EAMM-A-P3-28D-40P	1982014 EAMF-A-28D-40P	2310368 EAMC-16-20-3-8
With stepper motor			
EMMS-ST-28-...	1703478 EAMM-A-P3-28D-28A	1087613 EAMF-A-28D-28A	562672 EAMC-16-20-3-5
EGSK-20/EGSP-20			
With servo motor			
EMME-AS-40-...	1983071 EAMM-A-P4-28B-40P	1976704 EAMF-A-28B-40P	562675 EAMC-16-20-4-8
EMMS-AS-40-...	562637 EAMM-A-P4-28B-40A	552163 EAMF-A-28B-40A	562673 EAMC-16-20-4-6
With stepper motor			
EMMS-ST-28-...	1731466 EAMM-A-P4-28B-28A	1704476 EAMF-A-28B-28A	562674 EAMC-16-20-4-5
EMMS-ST-42-...	562636 EAMM-A-P4-28B-42A	552164 EAMF-A-28B-42A	562674 EAMC-16-20-4-5
EGSK-26/EGSP-26			
With servo motor			
EMME-AS-40-...	1983122 EAMM-A-P5-28B-40P	1976704 EAMF-A-28B-40P	562677 EAMC-16-20-5-8
EMMS-AS-40-...	562641 EAMM-A-P5-28B-40A	552163 EAMF-A-28B-40A	543419 EAMC-16-20-5-6
With stepper motor			
EMMS-ST-28-...	1731474 EAMM-A-P5-28B-28A	1704476 EAMF-A-28B-28A	562676 EAMC-16-20-5-5
EMMS-ST-42-...	562640 EAMM-A-P5-28B-42A	552164 EAMF-A-28B-42A	562676 EAMC-16-20-5-5
EGSK-33			
With servo motor			
EMME-AS-40-...	1983450 EAMM-A-P6-38A-40P	1984478 EAMF-A-38A-40P	533708 EAMC-30-32-6-8
EMMS-AS-40-...	562646 EAMM-A-P6-38A-40A	562667 EAMF-A-38A-40A	558312 EAMC-30-32-6-6
EMMS-AS-55-...	562647 EAMM-A-P6-38A-55A	558176 EAMF-A-38A-55A	551003 EAMC-30-32-6-9
EMME-AS-60-...	2264375 EAMM-A-P6-38A-60P	1987412 EAMF-A-38A-60P	1233256 EAMC-30-32-6-14
With stepper motor			
EMMS-ST-42-...	562644 EAMM-A-P6-38A-42A	562668 EAMF-A-38A-42A	561333 EAMC-30-32-5-6
EMMS-ST-57-...	562645 EAMM-A-P6-38A-57A	560692 EAMF-A-38A-57A	551002 EAMC-30-32-6-6.35
With integrated driver			
EMCA-EC-67-...	2297641 EAMM-A-P6-38A-67A	1490100 EAMF-A-38A-67A	551003 EAMC-30-32-6-9

Electric slides EGSK/EGSP

Accessories

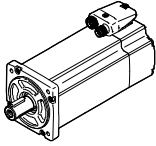
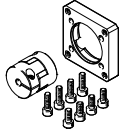
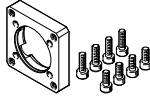
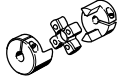

FESTO

Permissible axis/motor combinations with axial kit – Without gear unit				Technical data → Internet: eamm-a
Motor	Axial kit	Axial kit consisting of:		
		Motor flange	Coupling	
				
Type	Part No. Type	Part No. Type	Part No. Type	
EGSK-46/EGSP-33				
With servo motor				
EMME-AS-40-...	1986292 EAMM-A-P8-38A-40P	1984478 EAMF-A-38A-40P	543422 EAMC-30-32-8-8	
EMMS-AS-40-...	562652 EAMM-A-P8-38A-40A	562667 EAMF-A-38A-40A	533708 EAMC-30-32-6-8	
EMMS-AS-55-...	562653 EAMM-A-P8-38A-55A	558176 EAMF-A-38A-55A	543423 EAMC-30-32-8-9	
EMME-AS-60-...	1987308 EAMM-A-P8-38A-60P	1987412 EAMF-A-38A-60P	562682 EAMC-30-32-8-14	
EMMS-AS-70-...	564996 EAMM-A-P8-38A-70A	558018 EAMF-A-38A-70A	551004 EAMC-30-32-8-11	
With stepper motor				
EMMS-ST-42-...	562650 EAMM-A-P8-38A-42A	562668 EAMF-A-38A-42A	562678 EAMC-30-32-5-8	
EMMS-ST-57-...	562651 EAMM-A-P8-38A-57A	560692 EAMF-A-38A-57A	543421 EAMC-30-32-6.35-8	
EMMS-ST-87-...	564998 EAMM-A-P8-38A-87A	560693 EAMF-A-38A-87A	551004 EAMC-30-32-8-11	
With integrated driver				
EMCA-EC-67-...	2297643 EAMM-A-P8-38A-67A	1490100 EAMF-A-38A-67A	543423 EAMC-30-32-8-9	
EGSP-46				
With servo motor				
EMMS-AS-55-...	562659 EAMM-A-P10-38A-55A	558176 EAMF-A-38A-55A	562680 EAMC-30-32-9-10	
EMME-AS-60-...	2036017 EAMM-A-P10-38A-60P	1987412 EAMF-A-38A-60P	562683 EAMC-30-32-10-14	
EMMS-AS-70-...	564997 EAMM-A-P10-38A-70A	558018 EAMF-A-38A-70A	565008 EAMC-30-32-10-11	
With stepper motor				
EMMS-ST-57-...	562658 EAMM-A-P10-38A-57A	560692 EAMF-A-38A-57A	562679 EAMC-30-32-6.35-10	
EMMS-ST-87-...	564999 EAMM-A-P10-38A-87A	560693 EAMF-A-38A-87A	565008 EAMC-30-32-10-11	
With integrated driver				
EMCA-EC-67-...	2297644 EAMM-A-P10-38A-67A	1490100 EAMF-A-38A-67A	562680 EAMC-30-32-9-10	

Electric slides EGSK/EGSP

Accessories

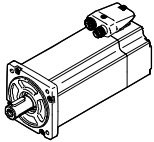
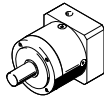
FESTO

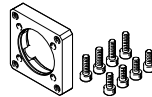
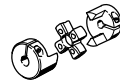
Permissible axis/motor combinations with axial kit – Without gear unit				Technical data → Internet: eamm-a	
Motor	Gear unit	Axial kit	Axial kit consisting of:		
			Motor flange	Coupling	
					
Type		Part-No. Type	Part-No. Type	Part-No. Type	
EGSK-33					
With servo motor					
EMME-AS-40-...	EMGA-40-P-G...-EAS-40	2297645 EAMM-A-P6-38A-40G	1460097 EAMF-A-38A-40G	562681 EAMC-30-32-6-10	
EMMS-AS-40-...	EMGA-40-P-G...-SAS-40	2297645 EAMM-A-P6-38A-40G	1460097 EAMF-A-38A-40G	562681 EAMC-30-32-6-10	
With stepper motor					
EMMS-ST-42-...	EMGA-40-P-G...-SST-42	2297645 EAMM-A-P6-38A-40G	1460097 EAMF-A-38A-40G	562681 EAMC-30-32-6-10	
With integrated drive					
EMCA-EC-67-...	EMGC-40-...	2297645 EAMM-A-P6-38A-40G	1460097 EAMF-A-38A-40G	562681 EAMC-30-32-6-10	
EGSK-46/EGSP-33					
With servo motor					
EMME-AS-40-...	EMGA-40-P-G...-EAS-40	2297646 EAMM-A-P8-38A-40G	1460097 EAMF-A-38A-40G	558029 EAMC-30-32-8-10	
EMMS-AS-40-...	EMGA-40-P-G...-SAS-40	2297646 EAMM-A-P8-38A-40G	1460097 EAMF-A-38A-40G	558029 EAMC-30-32-8-10	
With stepper motor					
EMMS-ST-42-...	EMGA-40-P-G...-SST-42	2297646 EAMM-A-P8-38A-40G	1460097 EAMF-A-38A-40G	558029 EAMC-30-32-8-10	
With integrated drive					
EMCA-EC-67-...	EMGC-40-...	2297646 EAMM-A-P8-38A-40G	1460097 EAMF-A-38A-40G	558029 EAMC-30-32-8-10	
EGSP-46					
With servo motor					
EMME-AS-40-...	EMGA-40-P-G...-EAS-40	2297648 EAMM-A-P10-38A-40G	1460097 EAMF-A-38A-40G	2310372 EAMC-30-32-10-10	
EMMS-AS-40-...	EMGA-40-P-G...-SAS-40	2297648 EAMM-A-P10-38A-40G	1460097 EAMF-A-38A-40G	2310372 EAMC-30-32-10-10	
With stepper motor					
EMMS-ST-42-...	EMGA-40-P-G...-SST-42	2297648 EAMM-A-P10-38A-40G	1460097 EAMF-A-38A-40G	2310372 EAMC-30-32-10-10	
With integrated drive					
EMCA-EC-67-...	EMGC-40-...	2297648 EAMM-A-P10-38A-40G	1460097 EAMF-A-38A-40G	2310372 EAMC-30-32-10-10	

Electric slides EGSK/EGSP

Accessories



Cross connecting kit EHAM

Materials:

Adapter plate: Anodised aluminium

Screws, locating pins: Steel

Conforms to RoHS

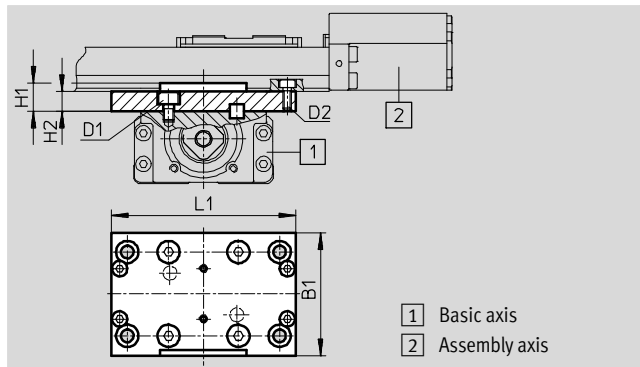

Dimensions and ordering data		B1	D1	D2	H1	H2	L1	Weight [g]	Part No.	Type
For size										
Basic axis	Assembly axis	±0.2					±0.2			
1	2									
20	15	33.2	M3	M3	7	5	56	27	563747	EHAM-S1-20-15
26	20	44	M4	M3	10	7	66	59	563748	EHAM-S1-26-20
33	26	54	M5	M4	12	9	86	124	563749	EHAM-S1-33-26
46	33	65	M6	M5	15	10	112	216	563750	EHAM-S1-46-33

Electric slides EGSK/EGSP

Accessories

Slide adapter EASA

Materials:

Adapter plate: Anodised aluminium

Screws, locating pins: Steel

Conforms to RoHS

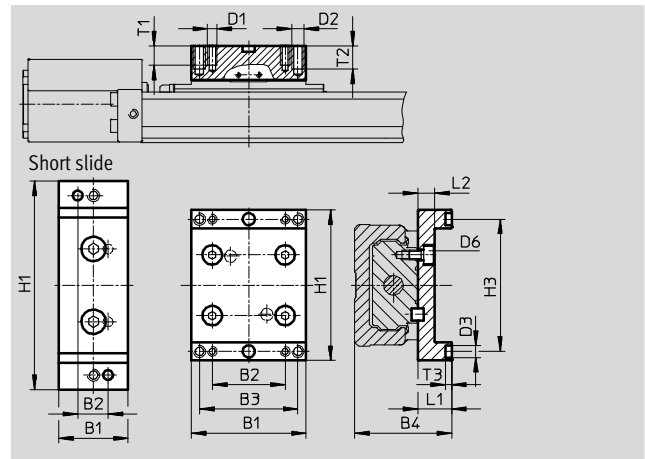

Dimensions and ordering data										
For size	B1	B2	B3	B4	D1	D2	D3	D6	H1	H3
	±0.2						∅ H7		±0.2	+0.04
With standard slide										
15	23	14	–	25	M3	–	4	M3	44	38
20	33.2	23	–	32	M3	–	2	M3	52	44.5
26	47.4	30	–	40	M4	–	5	M4	62	54.5
33	54	40	–	48	M5	–	4	M5	86	74
46	81	30	48	68	M5	M6	5	M6	112	100
With short slide										
33	28.5	12.5	–	48	M5	–	4	M5	86	74
46	48	22	–	68	M6	–	5	M6	112	100

For size	L1	L2	T1	T2	T3	Weight [g]	Part No.	Type
	+0.05				+0.1			
With standard slide								
15	10	5.4	6	–	2.5	20	562742	EASA-S1-15
20	12	6	6	–	2.5	38	562743	EASA-S1-20
26	14	7	8	–	2.5	74	562744	EASA-S1-26
33	15	9	15	–	2.6	130	562745	EASA-S1-33
46	22	10	10	12	2.6	310	562746	EASA-S1-46
With short slide								
33	15	9	15	–	2.6	70	562747	EASA-S1-33-S
46	22	10	12	–	2.6	180	562748	EASA-S1-46-S

Electric slides EGSK/EGSP

Accessories



Cover kit EASC
for standard slide

Materials:
Cover profile, adapter plate, adapter:
Anodised aluminium
Screws, locating pins: Steel
Conforms to RoHS

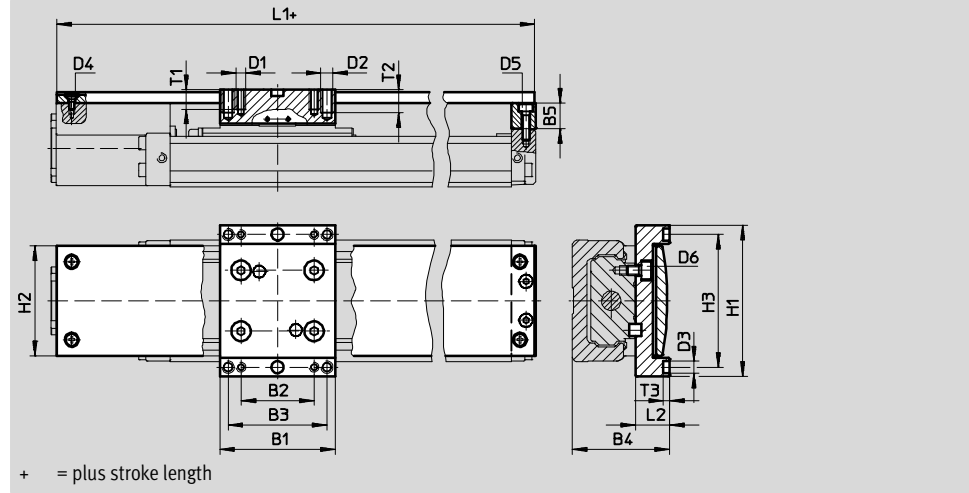

Dimensions										
For size	B1	B2	B3	B4	B5	D1	D2	D3 ∅ H7	D4	D5
	±0.2									
15	23	14	-	25	6.5	M3	-	4	M2	M2
20	33.2	23		32	9	M3		2	M2.5	M2.5
26	47.4	30		40	10.5	M4		5	M2.5	M3
33	54	40		48	7	M5		4	M3	M3
46	81	30	48	68	10	M5	M6	5	M4	M4

For size	D6	H1	H2	H3	L1	L2	T1	T2	T3
		±0.2	±0.2	±0.04	-0.3				+0.1
15	M3	44	30	38	96.7	10	6	-	2.5
20	M3	52	35.6	44.5	126.2	12	6		2.5
26	M4	62	45	54.5	156.2	14	8		2.5
33	M5	86	62.5	74	168.2	15	15		2.6
46	M6	112	82.4	100	224.7	22	10	12	2.6

Ordering data										
For size	Stroke [mm]	Weight [g]	Part No.	Type	For size	Stroke [mm]	Weight [g]	Part No.	Type	
15	25	51	562707	EASC-S1-15-25	33	100	327	562718	EASC-S1-33-100	
	50	57	562708	EASC-S1-15-50		200	391	562719	EASC-S1-33-200	
	75	62	562709	EASC-S1-15-75		300	454	562720	EASC-S1-33-300	
	100	67	562710	EASC-S1-15-100		400	518	562721	EASC-S1-33-400	
20	25	92	562711	EASC-S1-20-25		500	581	562722	EASC-S1-33-500	
	75	107	562712	EASC-S1-20-75		600	645	562723	EASC-S1-33-600	
	125	121	562713	EASC-S1-20-125		46	200	850	562724	EASC-S1-46-200
26	50	187	562714	EASC-S1-26-50			300	965	562725	EASC-S1-46-300
	100	211	562715	EASC-S1-26-100			400	1080	562726	EASC-S1-46-400
	150	234	562716	EASC-S1-26-150			500	1200	562727	EASC-S1-46-500
	200	258	562717	EASC-S1-26-200	600		1310	562728	EASC-S1-46-600	
					800		1540	562729	EASC-S1-46-800	

Electric slides EGSK/EGSP

Accessories

Cover kit EASC
for short slide

Materials:
Cover profile, adapter plate, adapter:
Anodised aluminium
Screws, locating pins: Steel
Conforms to RoHS

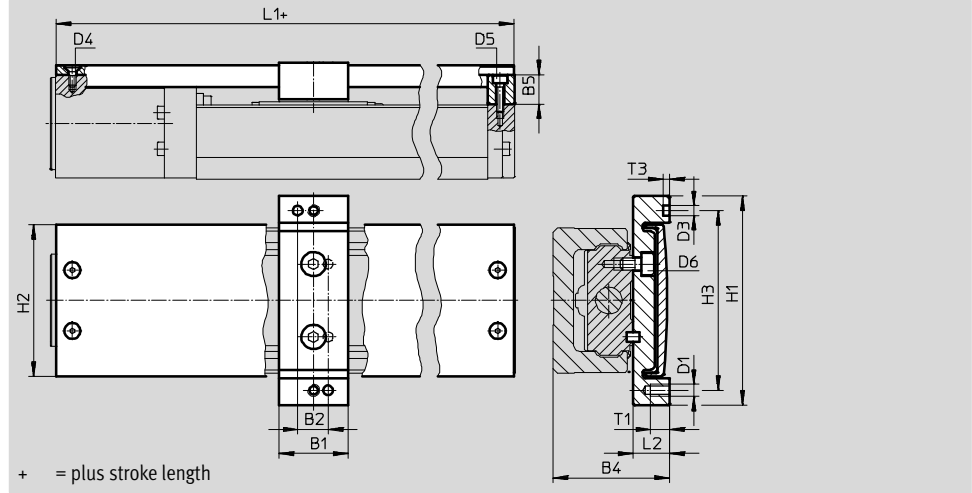

Dimensions								
For size	B1	B2	B4	B5	D1	D3	D4	D5
	±0.2	±0.04				∅ H7		
33	28.5	12.5	48	7	M5	4	M3	M3
46	48	22	68	10	M6	5	M4	M4

For size	D6	H1	H2	H3	L1	L2	T1	T3
		±0.2	±0.2	±0.04	-0.3			+0.1
33	M5	86	62.5	74	138.2	15	15	2.6
46	M6	112	82.4	100	184.7	22	12	2.6

Ordering data				
For size	Stroke [mm]	Weight [g]	Part No.	Type
33	130	263	562730	EASC-S1-33-130-S
	230	328	562731	EASC-S1-33-230-S
	330	391	562732	EASC-S1-33-330-S
	430	454	562733	EASC-S1-33-430-S
	530	518	562734	EASC-S1-33-530-S
	630	581	562735	EASC-S1-33-630-S
46	240	724	562736	EASC-S1-46-240-S
	340	840	562737	EASC-S1-46-340-S
	440	955	562738	EASC-S1-46-440-S
	540	1070	562739	EASC-S1-46-540-S
	640	1190	562740	EASC-S1-46-640-S
	840	1420	562741	EASC-S1-46-840-S

Electric slides EGSK/EGSP

Accessories

FESTO

Sensor rail EAPR

Materials:

Sensor bracket: Anodised aluminium

Switch lug, screws: Galvanised steel

Conforms to RoHS

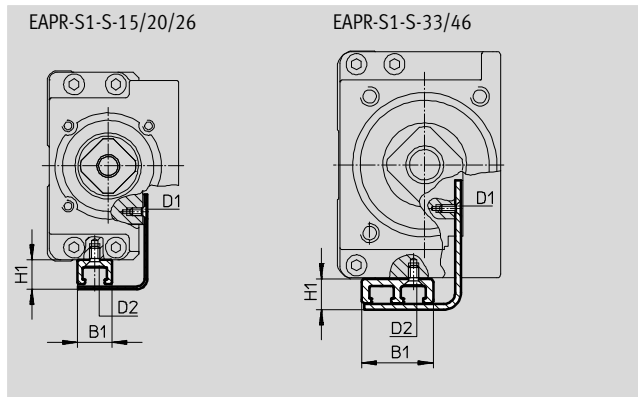

Dimensions						
For size	B1	H1		D1		D2
For type		EGSK	EGSP	EGSK	EGSP	
With standard slide						
15	9	8.5	–	M2	–	M2.5
20		7.75	7.75		M1.6	
26				M2		
33	19	7.75	8.5	M2	M2	M2.5
46						
With short slide						
33	19	7.5	8.5	M2	M2	M2.5
46		8.5				

Ordering data					
For size	Stroke	Weight	Part No.	Type	
For type	[mm]	[g]			
With standard slide					
15	25	10	562611	EAPR-S1-S-15-25	
	50	12	562612	EAPR-S1-S-15-50	
	75	14	562613	EAPR-S1-S-15-75	
	100	16	562614	EAPR-S1-S-15-100	
20	25	14	562615	EAPR-S1-S-20-25	
	75	18	562616	EAPR-S1-S-20-75	
	125	22	562617	EAPR-S1-S-20-125	
26	50	24	562618	EAPR-S1-S-26-50	
	100	28	562619	EAPR-S1-S-26-100	
	150	32	562620	EAPR-S1-S-26-150	
	200	37	562621	EAPR-S1-S-26-200	
With standard slide or short slide					
33	100/130-S	51	562622	EAPR-S1-S-33-100/130-S	
	200/230-S	69	562623	EAPR-S1-S-33-200/230-S	
	300/330-S	88	562624	EAPR-S1-S-33-300/330-S	
	400/430-S	106	562625	EAPR-S1-S-33-400/430-S	
	500/530-S	125	562626	EAPR-S1-S-33-500/530-S	
	600/630-S	144	562627	EAPR-S1-S-33-600/630-S	
46	200/240-S	78	562628	EAPR-S1-S-46-200/240-S	
	300/340-S	97	562629	EAPR-S1-S-46-300/340-S	
	400/440-S	115	562630	EAPR-S1-S-46-400/440-S	
	500/540-S	134	562631	EAPR-S1-S-46-500/540-S	
	600/640-S	153	562632	EAPR-S1-S-46-600/640-S	
	800/840-S	190	562633	EAPR-S1-S-46-800/840-S	

Electric slides EGSK/EGSP



Accessories

FESTO

Ordering data – Centring pins, centring sleeves					
	For size	Comment	Part No.	Type	PU ¹⁾
	15	For slide	189652	ZBH-5	10
	20		525273	ZBS-2	
	26, 46		150928	ZBS-5	
	33		562959	ZBS-4	
	15, 33	For slide adapter	562959	ZBS-4	
	20		525273	ZBS-2	
	26, 46		150928	ZBS-5	

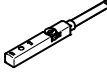
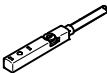
1) Packaging unit

Ordering data – Proximity sensors for T-slot, inductive					Technical data → Internet: sies	
	Type of mounting	Switching output	Electrical connection	Cable length [m]	Part No.	Type
N/O contact						
	Insertable in the slot from above, flush with the sensor rail	PNP	Cable, 3-wire	7.5	551386	SIES-8M-PS-24V-K-7,5-OE
			Plug M8x1, 3-pin	0.3	551387	SIES-8M-PS-24V-K-0,3-M8D
		NPN	Cable, 3-wire	7.5	551396	SIES-8M-NS-24V-K-7,5-OE
			Plug M8x1, 3-pin	0.3	551397	SIES-8M-NS-24V-K-0,3-M8D
N/C contact						
	Insertable in the slot from above, flush with the sensor rail	PNP	Cable, 3-wire	7.5	551391	SIES-8M-PO-24V-K-7,5-OE
			Plug M8x1, 3-pin	0.3	551392	SIES-8M-PO-24V-K-0,3-M8D
		NPN	Cable, 3-wire	7.5	551401	SIES-8M-NO-24V-K-7,5-OE
			Plug M8x1, 3-pin	0.3	551402	SIES-8M-NO-24V-K-0,3-M8D

Ordering data – Connecting cables				Technical data → Internet: nebu	
	Electrical connection, left	Electrical connection, right	Cable length [m]	Part No.	Type
	Straight socket, M8x1, 3-pin	Cable, open end, 3-wire	2.5	541333	NEBU-M8G3-K-2.5-LE3
			5	541334	NEBU-M8G3-K-5-LE3
	Angled socket, M8x1, 3-pin	Cable, open end, 3-wire	2.5	541338	NEBU-M8W3-K-2.5-LE3
			5	541341	NEBU-M8W3-K-5-LE3