

Cantilever systems

FESTO

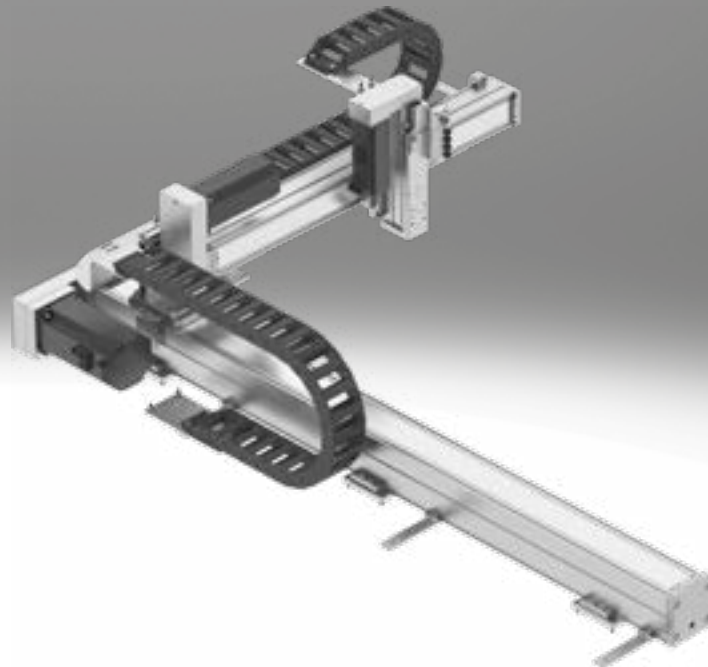

Characteristics

At a glance

The cantilever system facilitates movement in 3D space. The cantilever system is composed of several axis modules depending on the requirements. All of these are tried-and-tested components from Festo.

- Can be used universally for handling light to medium-weight workpieces or payloads
- Optimal installation space to working space ratio
- Working space with minimal interfering contours – freely accessible from three sides

- Pneumatic and electric components are freely combinable
- As an electrical solution it is freely positionable/any intermediate positions

Range of applications:

- For any movements in 3D space
- Ideal for line assembly processes
- Cost-effective handling unit in a compact format for small parts handling and simple tasks (YXCR-B)

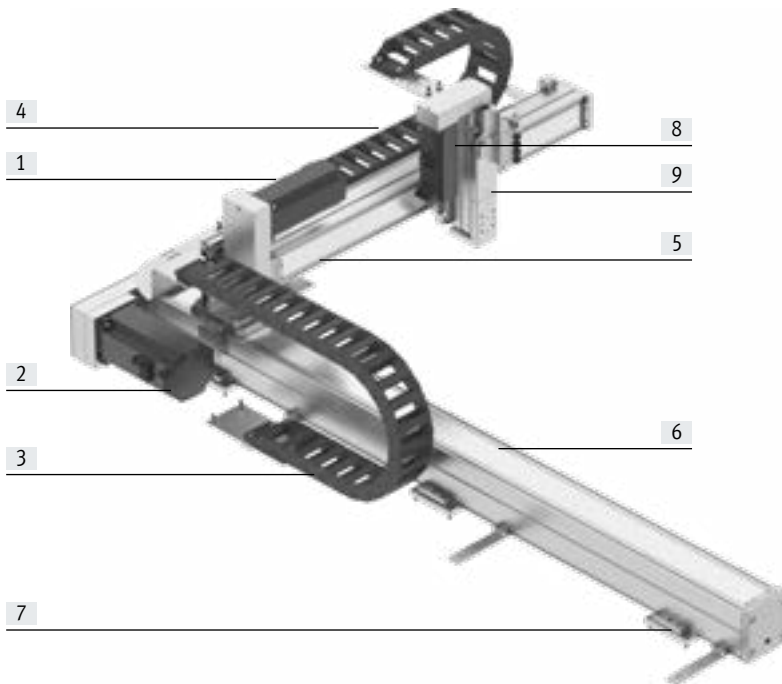

- [1] Servo motor for the Y-module
- [2] Servo motor for the X-module
- [3] Energy chain for the X-module
- [4] Energy chain for the Y-module
- [5] Y-axis
- [6] X-axis
- [7] Profile mounting/adjusting kit
- [8] Servo motor for the Z-module
- [9] Z-axis

Description of the modules

X-module

Design:

The X-module EHM-AS comprises a linear axis which is powered by a servo or stepper motor.

Adapters are mounted on the slide of the X-axis to connect the Y-module.

The position of the motor and energy chain can be selected using the configurator.

The following components are located on the motor side:

- Energy chain (optional)
- Multi-pin plug distributor for proximity switch (if a sensor package has been selected)

Sample image:

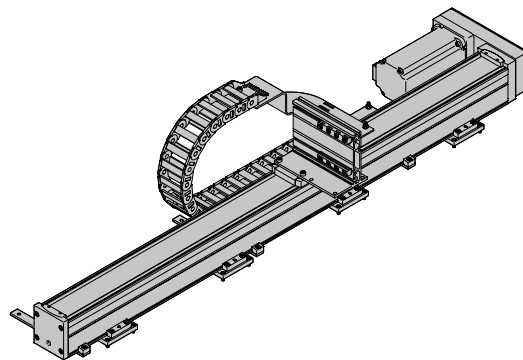

Characteristics

Description of the modules

Y-module

Design:

The Y-module EHYM comprises a linear axis which is powered by a servo or stepper motor.

Adapters are mounted on the slide of the Y-axis to connect the Z-module.

The position of the motor and energy chain is dependent on the position of the motor on the X-module.

The following components are located on the motor side:

- Energy chain (optional)
- Multi-pin plug distributor for proximity switch (if a sensor package has been selected)

Sample image:

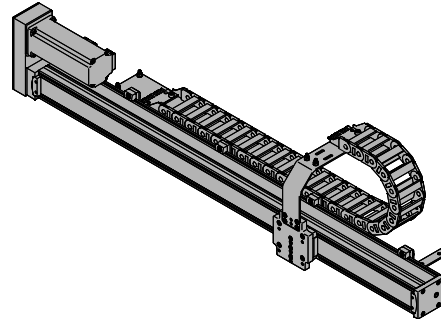

Z-module

Design:

The Z-module EHZM comprises an electric drive, the DHMZ comprises a pneumatic drive. Based on the configuration, an energy chain is optionally installed as a cable guide depending on the axis type and stroke.

The Z-module can be selected using the configurator, depending on the application.

Sample image:

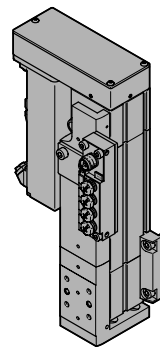

Characteristics

Dispatch options

Fully assembled:

The cantilever system is fully assembled. All cables and tubing are installed and connected. The system is already set up on delivery, but must be adapted to the particular mounting surface during installation.

Note flatness → table below.

Partially assembled:

The cantilever system is delivered partially assembled. This means that all three axis modules (X-/Y-/Z-axis) are assembled, each with the optional motors. The partially assembled system must be completed by the customer. Help can be found in the assembly instructions provided.

Optional accessories (→ page 9) are enclosed.

Note flatness → table below.

System overview ¹⁾		
Size	YXCA-1-B	YXCA-2-B
Max. working stroke	X: 800 mm Y: 300 mm Z: 150 mm	X: 1000 mm Y: 400 mm Z: 200 mm
Max. payload	Dependent on the selected dynamic response	
Required flatness of the mounting surface	≤ 0.1 mm/m	
Mounting position	Horizontal	

1) Drive package depends on the configuration selected.

Characteristics

Configurator: Handling Guide Online (HGO)

Selecting a handling system

Planning complex handling systems takes a lot of time. You can use the configurator "Handling Guide Online" (HGO) to design a customised handling system for your application in just a few steps.

You can choose from the following systems:

- Single-axis system
- 2D linear gantry
- 2D planar surface gantry
- 3D gantry
- 3D cantilever system

Advantages:

- Automatic selection of all relevant components
- Automatic design and calculation of the workload
- Quote created automatically
- CAD model available immediately
- Configuration-specific parameters for servo drives available immediately
- Complete Eplan project can be ordered according to the individual configuration
- Fully automated processing
- You can order fully or partially assembled systems through the Online Shop
- Lots of possible options

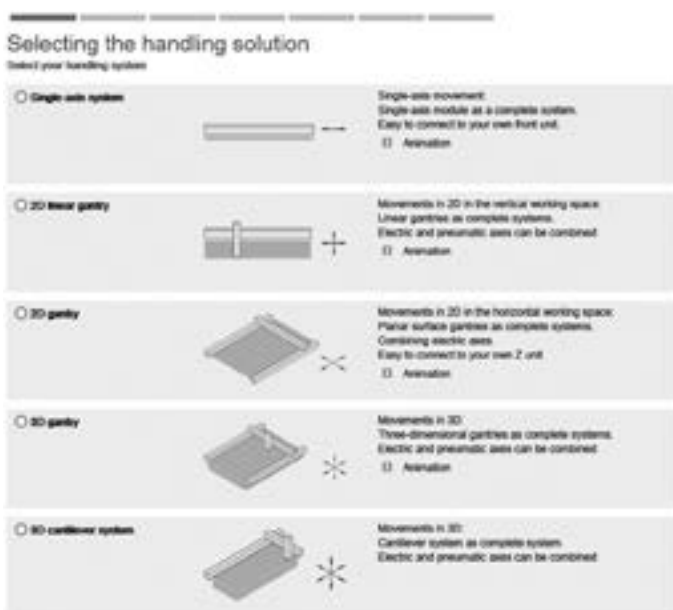

Entering the application data

- Payload
- Drive system of the axis
- Distance from the centre of the load
- Working stroke
- Reference cycle

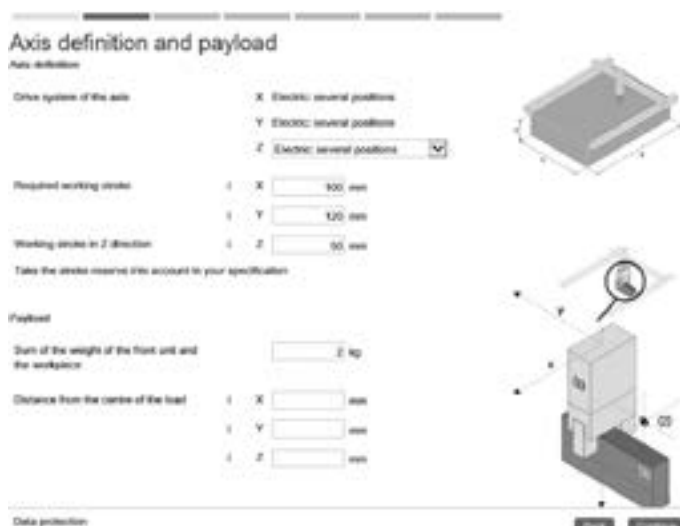

Characteristics

Configurator: Handling Guide Online (HGO)

Result of calculation

You will be offered a selection of systems calculated based on the application data you entered.

The following are available immediately:

- CAD model
- Datasheet of the selected system
- Price information

Result of calculation

Select the appropriate system and continue with the configuration:

No.	System name	System workload (l)	Dispensing accuracy (mm)	Your price
<input checked="" type="checkbox"/>	1 YXCR.1	31 %	0.15 mm	
<input type="checkbox"/>	2 YXCR.2	48 %	0.15 mm	
<input type="checkbox"/>	5 YXCR.2	52 %	0.15 mm	
<input type="checkbox"/>	7 YXCR.2	32 %	0.15 mm	
<input type="checkbox"/>	26 YXCR.2	48 %	0.7 mm	

Requires additional motion controller for interpolation (e.g. CPX-E-CEC-M1 ...)

3D gallery YXCR 1: #1

	X module: toothed belt axis	Y module: toothed belt axis	Z module: Electric nut drive
Drive module	ECC-50	ECC-50	ECC-35
Kinematics type	Serial kinematics	Serial kinematics	Serial kinematics
Stroke	200 mm	200 mm	50 mm
Dispensing accuracy (mm)	0.05 mm	0.05 mm	0.02 mm
Drive unit	S1	S1	Without
Type of motor	Servo motor (EMME-A)	Servo motor (EMME-A)	Servo motor (EMME-A)
Motor position	Right	Right	Top

Data protection

[Back](#) [Continue](#)

System overview

You will be given an overview of the complete system.

You will also have the following options:

- Show price
- Send request
- Add to basket

Your handling solution

Your selected system overview:

Exemplary representation



[Load CAD File](#)

Your system ID: **C1374165**

Your next steps:

- [Show price](#)
- [Send request](#)
- [Add to basket](#)

Your order | Your system | Your options

Feature	Value
Handling type	2D gantry
Payload	2 kg
Drive system of the X-axis	Electric serval position
Drive system of the Y-axis	Electric serval position

Data protection [Back](#)

Characteristics

Standard components within the handling system

The handling system comprises a number of tried-and-tested standard components from Festo. Different components are used depending on the configuration. The single axes installed will be displayed in the configurator HGO on the "Result of calculation" page.

Drives/axes

X-axis

Spindle axis ELGC-BS



- Electric
- Optimal installation space to working space ratio
- Protected against external influences by internal guide
- Various spindle pitches

Y-axis

Spindle axis ELGC-BS



- Electric
- Optimal installation space to working space ratio
- Protected against external influences by internal guide
- Various spindle pitches

Z-axis

Mini slide EGSC



- Electric
- Compact design
- High load capacity
- Precision guide and ball screw drive
- Easy adjustment of end positions

Mini slide DGST



- Pneumatic
- Precise and resilient roller bearing guide
- Slide and yoke plate as a single component
- High dynamic response

Possible axis combinations ¹⁾			
Size	X-module	Y-module	Z-module
YXCA-1-B	<ul style="list-style-type: none"> • Spindle axis ELGC-60-BS 	<ul style="list-style-type: none"> • Spindle axis ELGC-45-BS 	<ul style="list-style-type: none"> • Mini slide pneumatic: DGST-8/12 electric: EGSC-32
YXCA-2-B	<ul style="list-style-type: none"> • Spindle axis ELGC-80-BS 	<ul style="list-style-type: none"> • Spindle axis ELGC-60-BS 	<ul style="list-style-type: none"> • Mini slide pneumatic: DGST-12/16 electric: EGSC-45

1) Drive package depends on the configuration selected.

Characteristics

Standard components within the handling system

The handling system comprises a number of tried-and-tested standard components from Festo. Different components are used depending on the configuration. You can alter the scope and design of the drive package in the configurator HGO on the "System configuration" page.

Motors and controllers

Servo motors EMMB-AS



- Dynamic, brushless, permanently excited servo motor
- Digital absolute displacement encoder in single-turn or multi-turn version
- With optional brake

Stepper motors EMMS-ST



- Two-phase hybrid technology
- Step angle 1.8°
- With optional brake

Servo drive CMMT-AS, for servo motor



- Universal servo drive
- For synchronous servo motors
- Integrated EMC filters
- Integrated brake chopper
- Integrated braking resistor
- Position controller
- Speed controller
- Force controller
- Range of control functions

Options:

- Safety function: safe torque off (STO)/category 4, Performance Level e
- Safe stop 1 (SS1)
- Safe brake control (SBC) up to SIL3/category 3, Performance Level e

- Bus protocols
 - EtherCAT
 - PROFINET RT/IRT
 - EtherNet/IP
 - Modbus TCP

Servo drive CMMT-ST, for stepper motor



- Servo drive for operating stepper motors and brushless direct current motors
- Options for point-to-point and interpolating motion and for precise positioning
- Primary voltage from 24 ... 48 V DC
- Position controller
- Speed controller
- Force controller
- Range of control functions

Options:

- Safety function: safe torque off (STO)/category 3, Performance Level e
- Safe stop 1 time controlled (SS1-t)

- Bus protocols
 - EtherCAT
 - PROFINET RT/IRT
 - EtherNet/IP
 - Modbus TCP

Ordering data – Accessories

Module/motor combinations

We recommend that the three-dimensional gantry is operated with the proposed motors from Festo. These precisely match the mechanical system. When using third-party motors, it is essential that the technical limits are observed.

Module	Motor	
	Servo motor	Stepper motor
X-module		
EHMX-ELGC-60-BS	EMMB-AS-80-07	EMMS-ST-57-M
EHMX-ELGC-80-BS	EMMB-AS-80-07	EMMS-ST-87-M
Y-module		
EHMY-RP-ELGC-45-BS	EMMB-AS-40-01	EMMS-ST-42-S
EHMY-RP-ELGC-60-BS	EMMB-AS-60-04	EMMS-ST-57M
Z-module		
EHMZ-EGSC-32	EMMB-AS-40-01	EMMS-ST-42-S
EHMZ-EGSC-45	EMMB-AS-40-01	EMMS-ST-42-S

Ordering data – Accessories

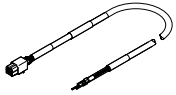
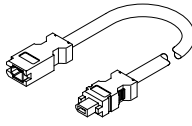
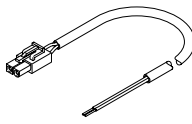
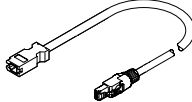
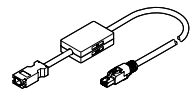
Ordering data		Cable length [m]	Part no.	Type
For servo motor EMMB-AS				
Motor cable				
 <ul style="list-style-type: none"> For EMMB-AS-40/60/80 with CMMT-AS 	2.5	5219197	NEBM-H6G4-E-2.5-Q13N-LE4	
	5	5219198	NEBM-H6G4-E-5-Q13N-LE4	
	7.5	5219199	NEBM-H6G4-E-7.5-Q13N-LE4	
	10	5219200	NEBM-H6G4-E-10-Q13N-LE4	
	15	8097203	NEBM-H6G4-E-15-Q13N-LE4	
Encoder cable				
 <ul style="list-style-type: none"> For EMMB-AS-40/60/80 with CMMT-AS 	2.5	5219213	NEBM-REG6-E-2.5-Q14N-REG6	
	5	5219214	NEBM-REG6-E-5-Q14N-REG6	
	7.5	5219215	NEBM-REG6-E-7.5-Q14N-REG6	
	10	5219216	NEBM-REG6-E-10-Q14N-REG6	
	15	8097200	NEBM-REG6-E-15-Q14N-REG6	
Connecting cable for brake				
 <ul style="list-style-type: none"> For EMMB-AS-40/60/80 with CMMT-AS 	2.5	5219205	NEBM-H7G2-E-2.5-Q14N-LE2	
	5	5219206	NEBM-H7G2-E-5-Q14N-LE2	
	7.5	5219207	NEBM-H7G2-E-7.5-Q14N-LE2	
	10	5219208	NEBM-H7G2-E-10-Q14N-LE2	
	15	8097206	NEBM-H7G2-E-15-Q14N-LE2	
Adapter for encoder cable (absolutely essential)				
 <ul style="list-style-type: none"> For EMMB-AS-40/60/80 with CMMT-AS 	For single-turn version with CMMT-AS			
	0.5	8097197	NEFM-REG6-K-0.5-R3G8	
 <ul style="list-style-type: none"> For EMMB-AS-40/60/80 with CMMT-AS 	For multi-turn version with CMMT-AS¹⁾			
	0.5	8097195	NEFM-REG6-K-0.5-B-R3G8	
	For multi-turn version with CMMB-AS¹⁾			
0.5	8097196	NEFM-REG6-K-0.5-B-REG6		

1) The required battery is not included in the scope of delivery

Ordering data – Accessories

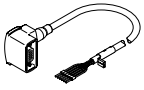
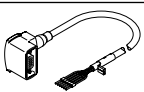
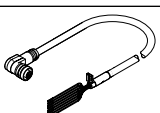
Designation	Description	Cable length [m]	Part no.	Type
For stepper motor EMMS-ST				
Motor cable¹⁾				
	<ul style="list-style-type: none"> For stepper motor EMMS-ST-42/57 with CMMT-ST Angled plug 	2.5	1450737	NEBM-S1W9-E-2.5-Q5-LE6
		5	1450738	NEBM-S1W9-E-5-Q5-LE6
		7	1450739	NEBM-S1W9-E-7-Q5-LE6
		10	1450740	NEBM-S1W9-E-10-Q5-LE6
		15	610856	NEBM-S1W9-E-15-Q5-LE6
	<ul style="list-style-type: none"> For stepper motor EMMS-ST-87 with CMMT-ST Angled plug 	2.5	1450944	NEBM-S1W15-E-2.5-Q7-LE6
		5.0	1450945	NEBM-S1W15-E-5-Q7-LE6
		7.0	1450946	NEBM-S1W15-E-7-Q7-LE6
		10	1450947	NEBM-S1W15-E-10-Q7-LE6
		15	610857	NEBM-S1W15-E-15-Q7-LE6
Encoder cable¹⁾				
	<ul style="list-style-type: none"> For stepper motor EMMS-ST-42/57/87 with CMMT-ST Angled plug 	2.5	1451675	NEBM-M12W8-E-2.5-LE8
		5	1451676	NEBM-M12W8-E-5-LE8
		7	1451677	NEBM-M12W8-E-7-LE8
		10	1451678	NEBM-M12W8-E-10-LE8
		15	610858	NEBM-M12W8-E-15-LE8

1) Cables especially suitable for the motor controller and motor.
Degree of protection to IP65 (in assembled state)

Possible cable and tube lengths

- Cables and tubing are selected so that the length specified when ordering will be the minimum connection length from the energy chain output.
- Cables and tubing are only available in fixed lengths as stated in the table below. This can mean that the cable plugs of the different cables do not end at the same point.

Length	1 m	2 m	5 m	7 m	10 m
Motor cable	–	■	■	■	■
Encoder cable	–	■	■	■	■
Multi-pin plug connecting cable	–	■	■	■	■
Tubing (for DHMZ only)	■	■	■	–	–



Ordering data – Accessories

Standard components within the handling system

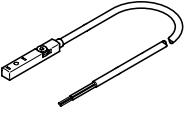
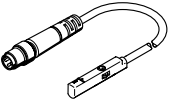
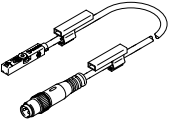
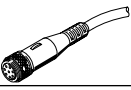
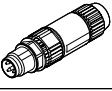
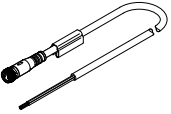
The handling system comprises a number of tried-and-tested standard components from Festo. Different components are used depending on the configuration. You can alter the scope and design of the accessories in the configurator HGO on the "System configuration" page.

Designation	Description	Cable length	Part no.	Type	
Proximity switch (inductive) for sensing the position of the slide on the X-/Y-/Z-axis					
	Cable with open end				
	<ul style="list-style-type: none"> For spindle axis ELGC-BS For mini slide EGSC For DC voltage Included if the "Festo sensor package" is selected: <ul style="list-style-type: none"> For ELGC: 2 pieces For EGSC: 1 piece 	PNP, N/C contact	7.5 m	551391	SIES-8M-PO-24V-K-7.5-OE
		PNP, N/O contact	7.5 m	551386	SIES-8M-PS-24V-K-7.5-OE
		NPN, N/C contact	7.5 m	551401	SIES-8M-NO-24V-K-7.5-OE
		NPN, N/O contact	7.5 m	551396	SIES-8M-NS-24V-K-7.5-OE
Proximity switches (magneto-resistive) for sensing the position of the slide on the Z-axis					
	<ul style="list-style-type: none"> For mini slide DGST-8/-12 For DC voltage Included if the "Festo sensor package" is selected: <ul style="list-style-type: none"> 2 pieces 	PNP, N/O contact	2.5 m	551375	SMT-10M-PS-24V-E-0.3-L-M8D
		NPN, N/O contact	2.5 m	551379	SMT-10M-NS-24V-E-0.3-L-M8D
	<ul style="list-style-type: none"> For mini slide DGST-16/-20 For DC voltage Included if the "Festo sensor package" is selected: <ul style="list-style-type: none"> 2 pieces 	PNP, N/O contact	2.5 m	574334	SMT-8M-A-PS-24V-E-0.3-M8D
		NPN, N/O contact	2.5 m	574339	SMT-8M-A-NS-24V-E-0.3-M8D
Plug socket with cable					
	<ul style="list-style-type: none"> Connection between multi-pin plug distributor NEDU and control cabinet 	5 m	525618	SIM-M12-8GD-5-PU	
		10 m	570008	SIM-M12-8GD-10-PU	
Plug					
	<ul style="list-style-type: none"> For connection to the multi-pin plug distributor NEDU / distributor NEDY 	–	562024	NECU-S-M8G3-HX	
Connecting cable					
	<ul style="list-style-type: none"> Connection between distributor NEDY and control cabinet 	2.5	541342	NEBU-M8G4-K-2.5-LE4	
		5	541343	NEBU-M8G4-K-5-LE4	
		7.5	610854	NEBU-M8G4-K-7.5-LE4	
		10	589560	NEBU-M8G4-K-10-LE4	
		15	610855	NEBU-M8G4-K-15-LE4	

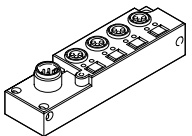
Ordering data – Accessories

Designation	Description	Cable length	Part no.	Type
Multi-pin plug distributor				
	<ul style="list-style-type: none"> With the help of the multi-pin plug distributor, electrical signals such as for end-position sensing can be transferred collectively – 4 individual connections 	–	574586	NEDU-L4R1-M8G3L-M12G8
	<ul style="list-style-type: none"> With the help of the distributor, electrical signals such as for end-position sensing can be transferred collectively – 2 individual connections 	–	8005312	NEDY-L2R1-V1-M8G3-N-M8G4

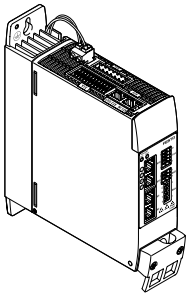
Designation	Description
Motor controller/servo drive	
	The accessories for the relevant motor controllers/servo drives can be found at: <ul style="list-style-type: none"> www.festo.com/catalogue/cmmt

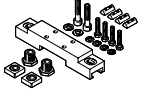
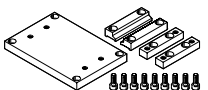
Designation	Description	Part no.	Type
Adjusting kit			
	<ul style="list-style-type: none"> Used to mount the handling system on the supporting surface Can be used to easily compensate for any unevenness in the supporting surface 	EHMx-...-ELGC-60-BS	8142650 EADC-E15-60-E22
		EHMx-...-ELGC-80-BS	8142651 EADC-E15-80-E22
Profile mounting			
	<ul style="list-style-type: none"> Used to mount the handling system on the supporting surface It is not height-adjustable 	EHMx-...-ELGC-60-BS	8142652 EAHM-E15-60-E22
		EHMx-...-ELGC-80-BS	8142653 EAHM-E15-80-E22

Programming aid

Festo Automation Suite

Parameterisation and programming software for electronic devices from Festo

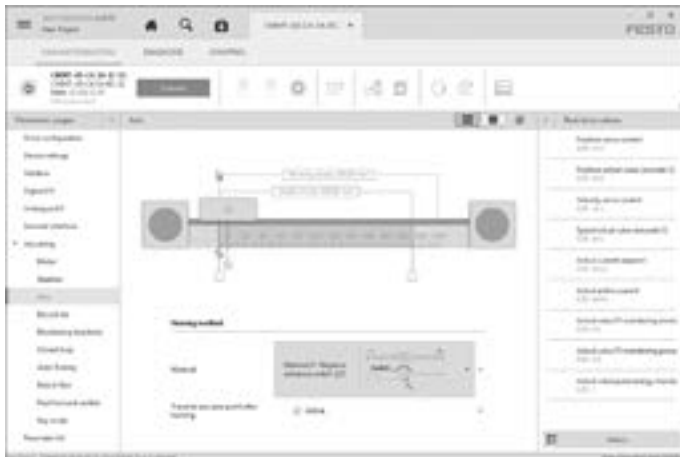

- Parameterisation, programming and commissioning in a clear and user-friendly interface
- Optimum support for complex processes thanks to guided wizards (e.g. for commissioning, drive configuration, etc.)
- Fast access to the required documents and additional information
- Easy integration of electric drives in the controller programming