

Proportional-pressure regulators VPPM

FESTO

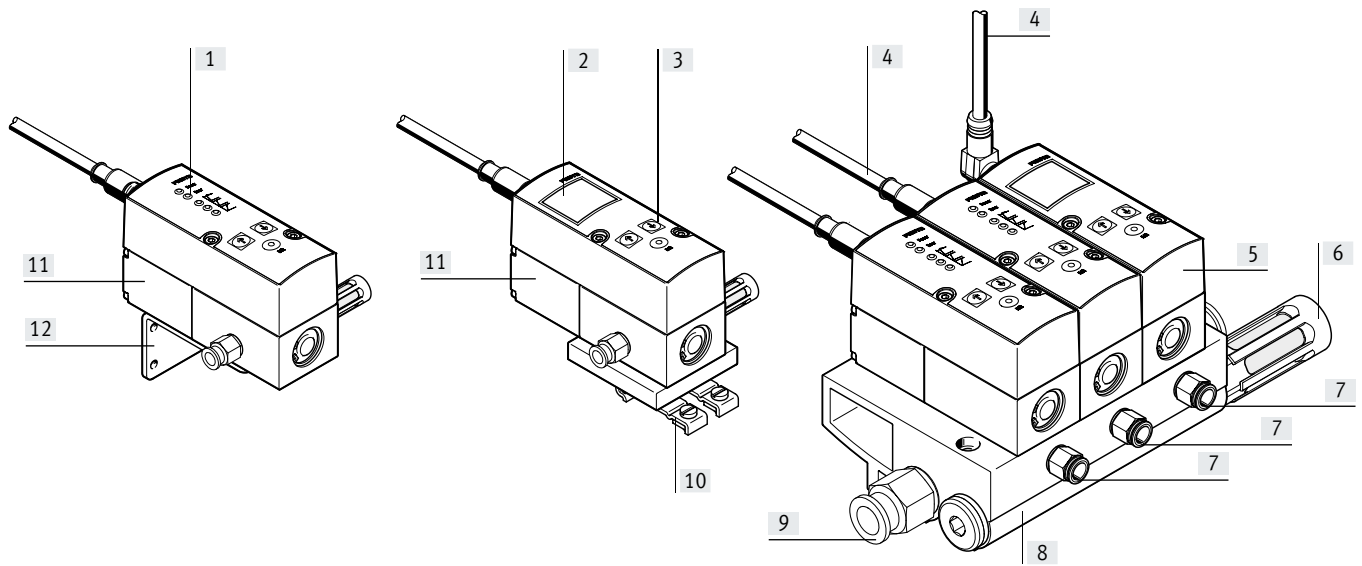

Key features – Overview



- | | | | |
|----------------------------|--------------------------|--|--|
| [1] LED displays | [5] Sub-base valve | [9] Compressed air supply at both ends | [11] Individual valve |
| [2] Display window | [6] Exhaust at both ends | [10] H-rail mounting | [12] Angle bracket can be rotated 180° during mounting |
| [3] Control elements | [7] Working ports | | |
| [4] Plug socket with cable | [8] Manifold block | | |

Innovative

- Multi-sensor control (cascade control)
- Diagnostics
- Choice of regulation characteristic
- Temperature compensated
- High dynamic response
- High repetition accuracy
- Processing of modular products
- IO-Link, for direct connection to a higher-level IO-Link/I-Port master

Flexible

- Individual valves (in-line valve)
- Sub-base valves (battery/sub-base valve)
- Various user interfaces
 - LED displays
 - LCD display
 - Adjustment/selection buttons
- Choice of valves with different pressure ranges
- Pressure range can be modified on the valve
- Choice of different setpoint specifications
 - Current input
 - Voltage input

Operational safety

- Integrated pressure sensor with separate output
- Wire break monitoring
- Pressure maintained if controller fails

Easy to install

- Manifold block (manifold)
- H-rail mounting
- Individually via mounting bracket
- QS fittings

Key features – Overview

Overview, VPPM IO-Link

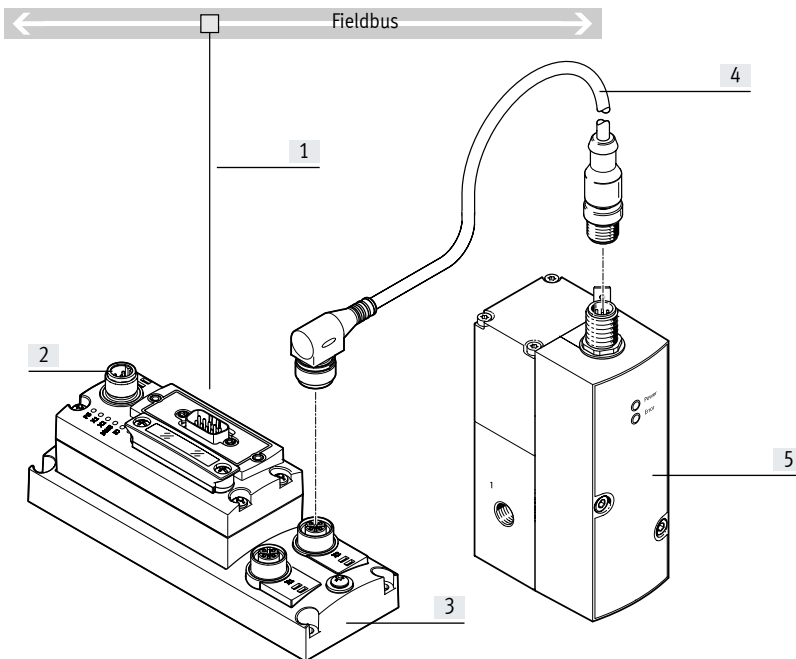

- [1] Diagnostics via fieldbus
- [2] Bus node
- [3] Electrical connection block CAPC
- [4] Connecting cable NEBU
- [5] Proportional-pressure regulator VPPM with IO-Link

Key features – VPPM on valve terminal

Overview, VPPM on the valve terminal MPA-S

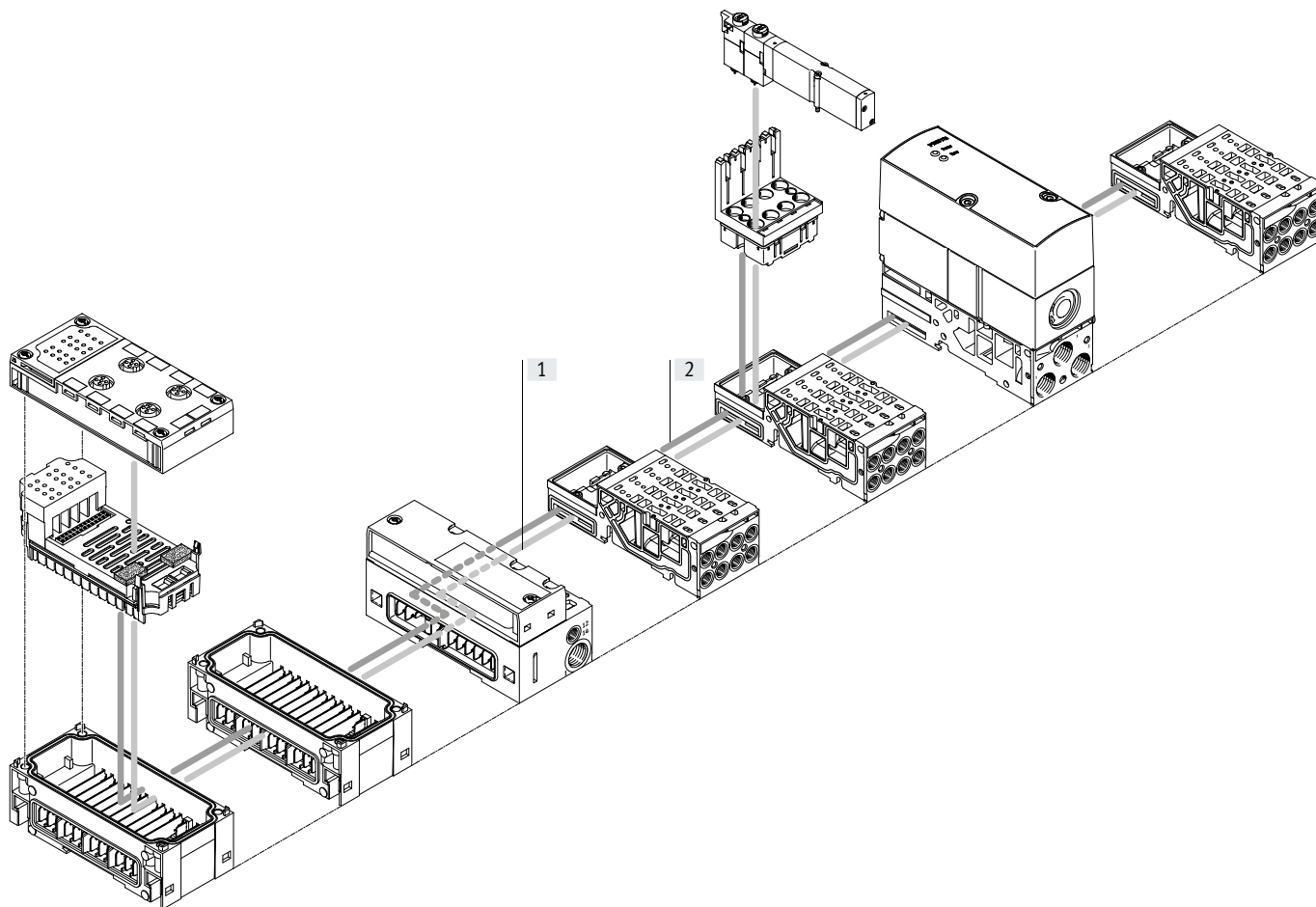

[1] 24 V

[2] Serial data

Innovative

- Multi-sensor control
- Diagnostics via the bus
- Choice of regulation characteristic
- High dynamic response
- 2 accuracy levels

Flexible

- For all common protocols
- As an individual pressure regulator
- As a pressure zone regulator
- Choice of 3 valves with different pressure ranges
- 3 pressure ranges (presets) can be set via the bus
- Internal or external compressed air supply possible

Operational safety

- Long service life
- LED display for the operating status
- Pressure maintained in case of supply voltage failure
- Fast troubleshooting with LEDs on the valves and diagnostics via fieldbus
- Ease of servicing with replaceable valves

Easy to install

- Easy replacement of the valves
- Tested units
- Easy extension of the valve terminal

Note

More information on the VPPM valves for MPA-S
→ mpas

Key features – Control loop

Layout of a control loop

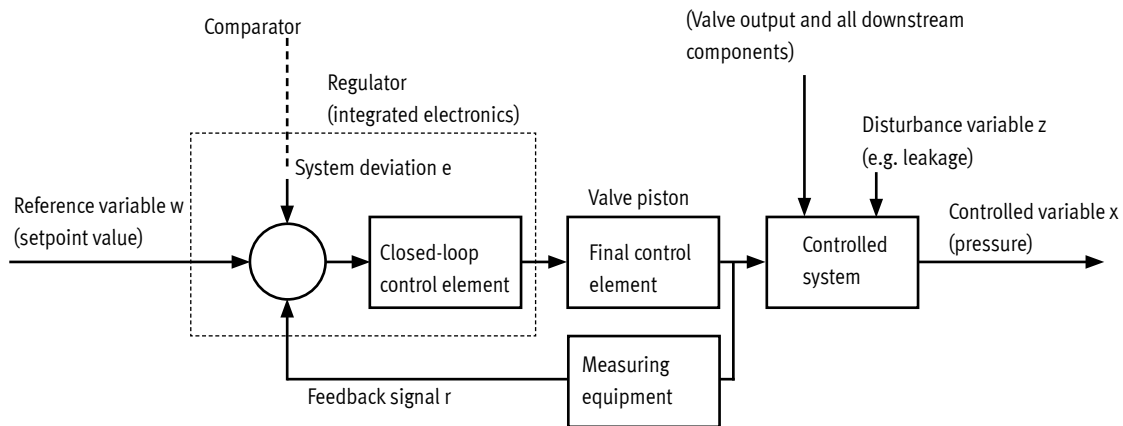

Design

The figure shows a closed loop control. The reference variable w (setpoint value, e.g. 5 V or 8 mA) initially acts on a comparator. The measuring equipment sends the controlled variable x value (actual value, e.g. 3 bar) to the comparator as a feedback signal r . The closed-loop control element detects the system deviation e and actuates the final control element. The output of the final control element acts on the

controlled system. The closed-loop control element thus attempts to compensate for the difference between the reference variable w and the controlled variable x by using the final control element.

Method of operation

This process runs continuously so changes in the reference variable are always detected. However, a system deviation will also occur if the reference variable is constant and the controlled variable changes. This happens when the flow through the valve changes in response to a switching operation, a cylinder movement or a load change. The disturbance variable z will also cause a system deviation. An

example of this is when the pressure drops in the air supply. The disturbance variable z acts on the controlled variable x in an unforeseen way. In all cases, the closed-loop controller attempts to correct the controlled variable x to the reference variable w .

Multi-sensor control (cascade control) of the VPPM

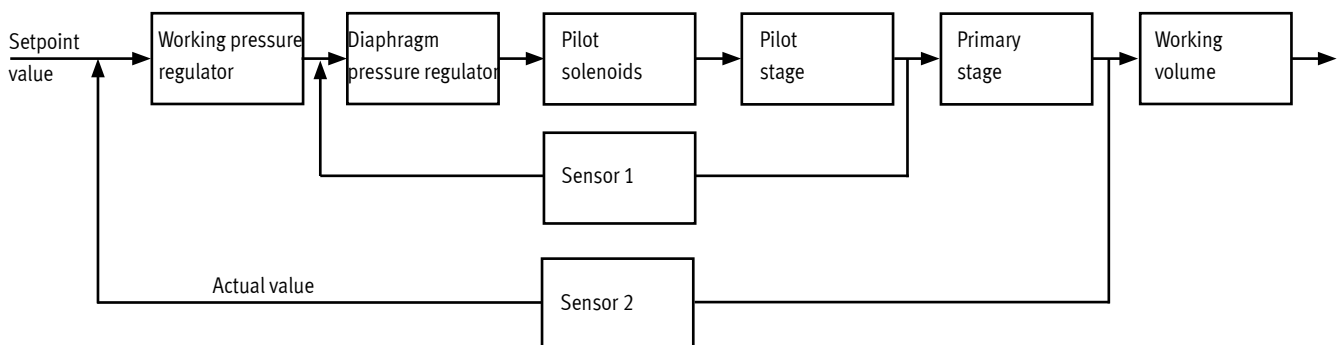

Cascade controller

Unlike conventional direct-acting controls, in multi-sensor controls multiple control loops are nested inside one other. The overall controlled system is divided into smaller sub-sections that

are easier to control for the specific task.

Control precision

Control accuracy and dynamic response are greatly improved with the multi-sensor control principle in comparison with a single-acting regulator.

Key features – Control loop

Terms related to the proportional-pressure regulator

Hysteresis

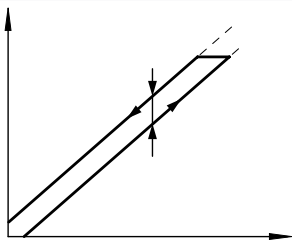

There is always a linear relationship within a certain tolerance between the setpoint value entered and the pressure output. Nevertheless, it makes a difference whether the setpoint value is entered as rising or falling. The difference between the maximum deviations is referred to as hysteresis.

Response sensitivity

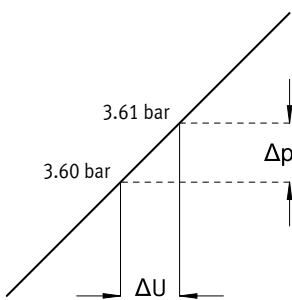

The response sensitivity of the device determines how sensitively one can change, i.e. adjust, a pressure. The smallest setpoint value difference that results in a change in the output pressure is referred to as the response sensitivity. In this case, 0.01 bar.

Zero point offset

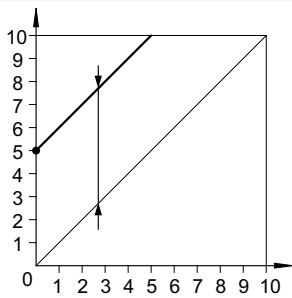

If, for example, a VPPM cannot be exhausted for safety reasons, the minimum pressure can be increased from the zero point. The smallest setpoint value is then assigned an output pressure of 5 bar, for example, and the largest setpoint value an output pressure of 10 bar. Zero point suppression is automatically switched off if the zero point offset is used.

Zero point suppression

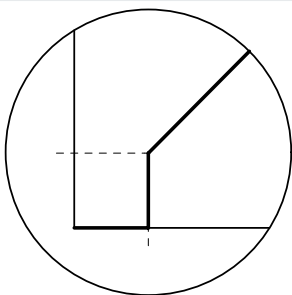

In real-world applications, it is possible for there to be a residual voltage or residual current at the setpoint input of the VPPM via the setpoint generator. Zero point suppression is used so the valve is reliably exhausted at a setpoint value of zero.

Linearity error

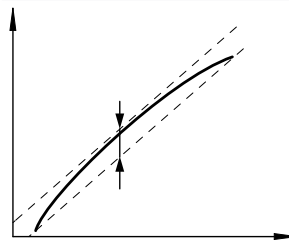

A perfectly linear progression of the control characteristic of the output pressure is theoretical. The maximum percentage deviation from this theoretical control characteristic is referred to as the linearity error. The percentage value refers to the maximum output pressure. (full scale)

Repetition accuracy (reproducibility)

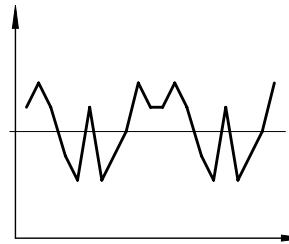

The repetition accuracy is the margin within which the fluid output variables are scattered when the same electrical input signal coming from the same direction is repeatedly adjusted. The repetition accuracy is expressed as a percentage of the maximum fluid output signal.

Pressure range adaptation

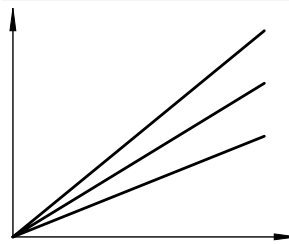

In the delivery status, 100% setpoint value corresponds to 100% of the fluid output signal. Pressure range adaptation or adjustment enables the fluid output variable to be matched to the setpoint value.

Key features – Flow rate

Flow rate q_{n1} of 1 → 2 as a function of excess output pressure p_2

VPPM-6L/F...-0L2H... (2 bar)

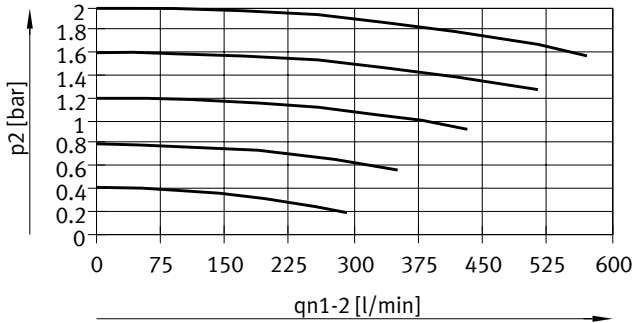

VPPM-6L/F...-0L6H... (6 bar)

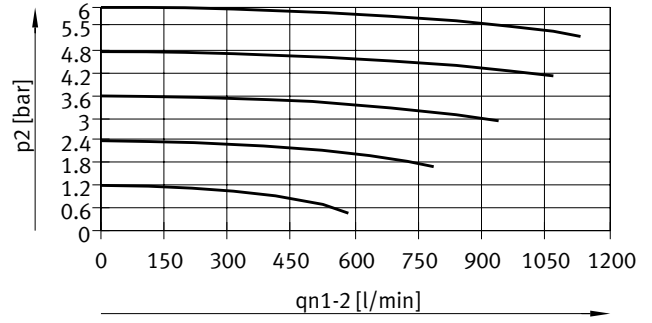

VPPM-6L/F...-0L10H... (10 bar)

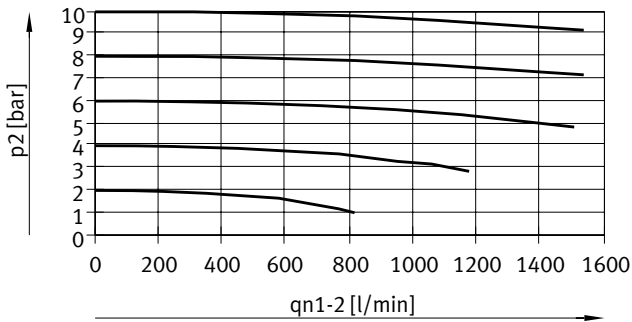

Flow rate q_{n2} of 2 → 3 as a function of excess output pressure p_2

VPPM-6L/F...-0L2H... (2 bar)

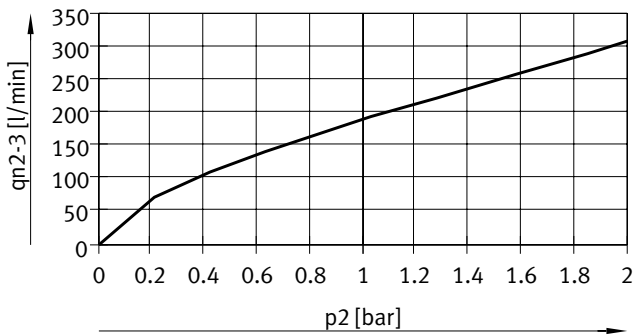

VPPM-6L/F...-0L6H... (6 bar)

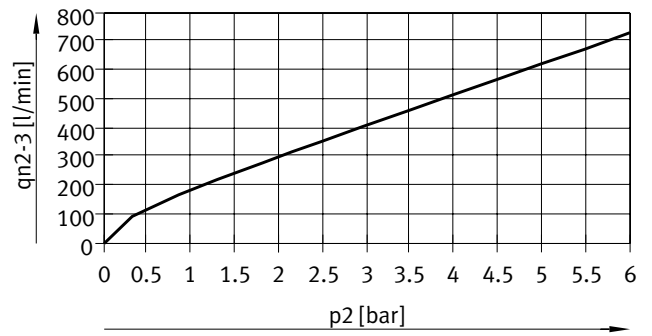

VPPM-6L/F...-0L10H... (10 bar)



Key features – Flow rate

Flow rate q_n of 1 → 2 as a function of excess output pressure p_2

VPPM-8L...-0L2H-...

(2 bar)

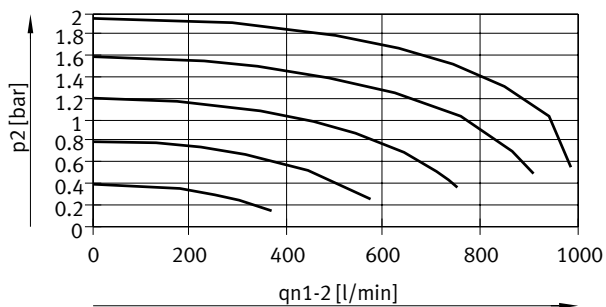

VPPM-8L...-0L6H-...

(6 bar)

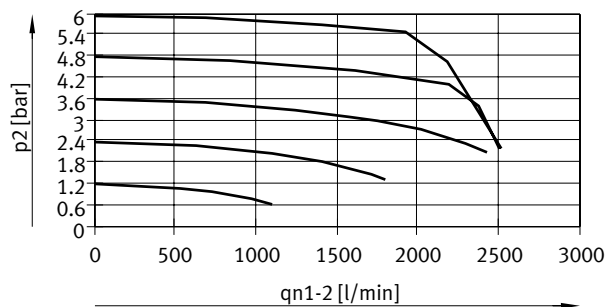

VPPM-8L...-0L10H-...

(10 bar)

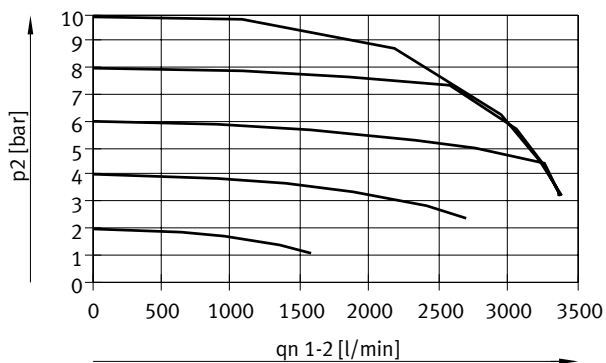

Flow rate q_n of 2 → 3 as a function of excess output pressure p_2

VPPM-8L...-0L2H-...

(2 bar)

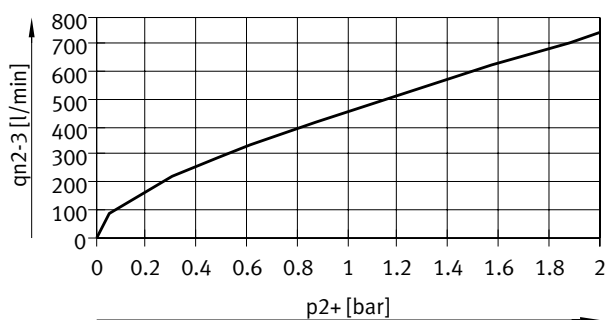

VPPM-8L...-0L6H-...

(6 bar)

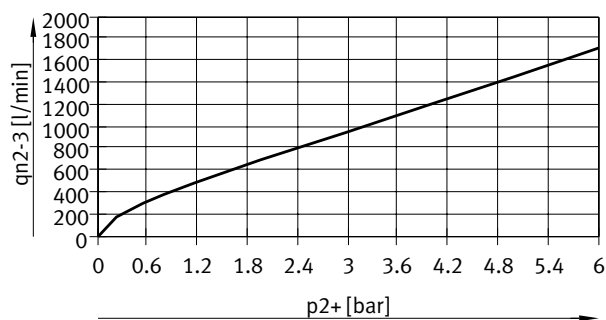

VPPM-8L...-0L10H-...

(10 bar)

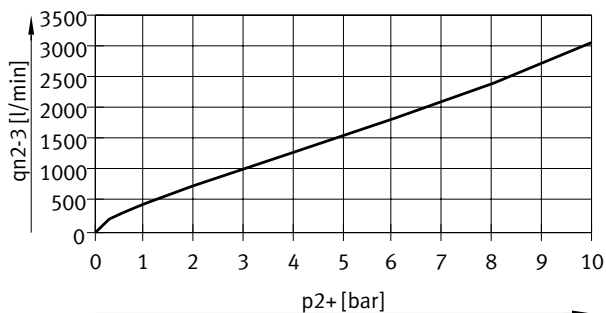

Key features – Flow rate

Flow rate $q_{n1 \rightarrow 2}$ as a function of excess output pressure p_2

VPPM-8F/8TA-...-0L2H-... (2 bar)

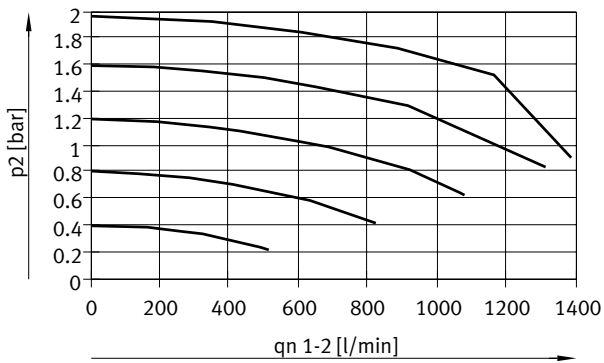

VPPM-8F/8TA-...-0L6H-... (6 bar)

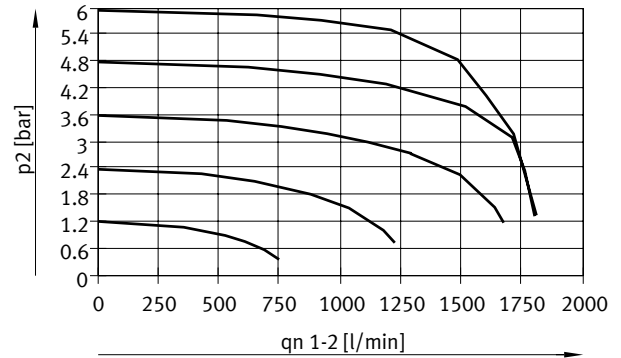

VPPM-8F/8TA-...-0L10H-... (10 bar)

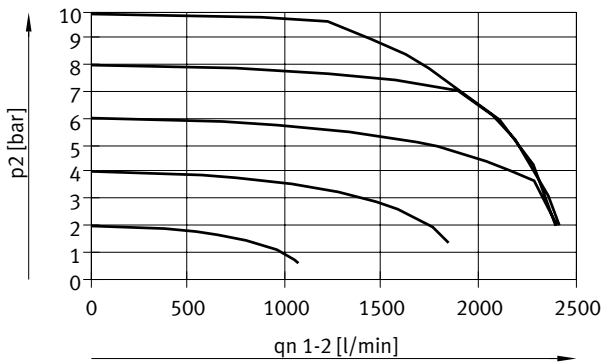

Flow rate $q_{n2 \rightarrow 3}$ as a function of excess output pressure p_2

VPPM-8F/8TA-...-0L2H-... (2 bar)

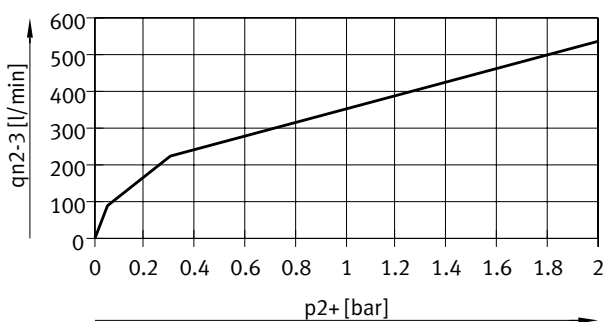

VPPM-8F/8TA-...-0L6H-... (6 bar)

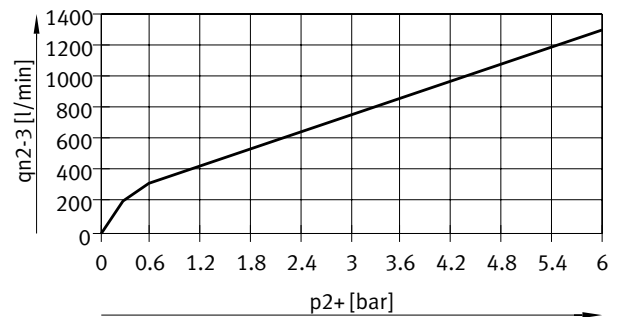

VPPM-8F/8TA-...-0L10H-... (10 bar)



Key features – Flow rate

Flow rate q_{n1} of 1 → 2 as a function of excess output pressure p_2

VPPM-12L...-0L2H-...

(4 bar)

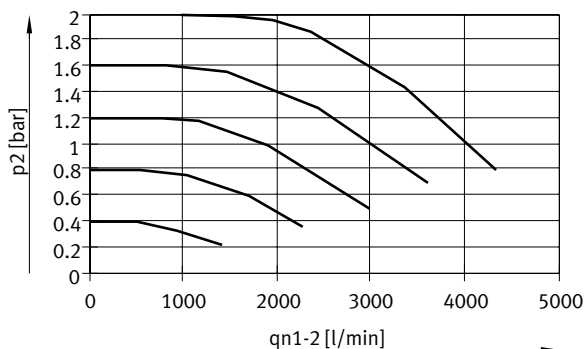

VPPM-12L...-0L6H-...

(8 bar)

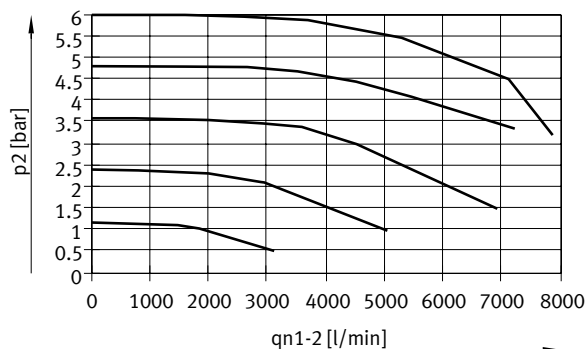

VPPM-12L...-0L10H-...

(11 bar)

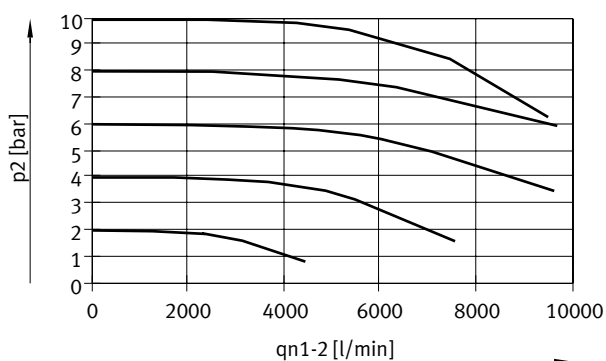

Flow rate q_{n2} of 2 → 3 as a function of excess output pressure p_2

VPPM-12L...-0L2H-...

(4 bar)

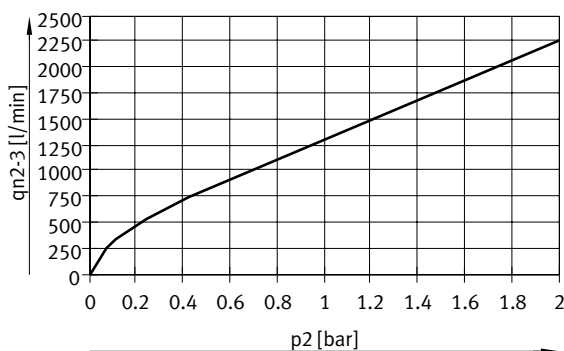

VPPM-12L...-0L6H-...

(8 bar)

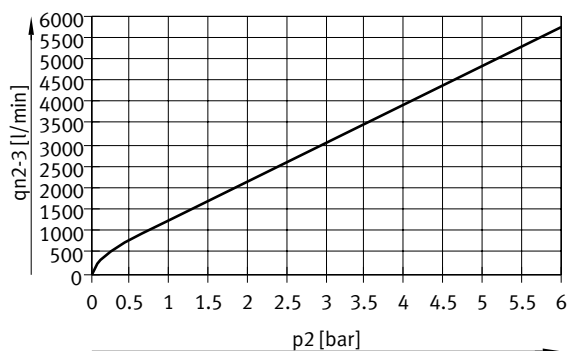

VPPM-12L...-0L10H-...

(11 bar)

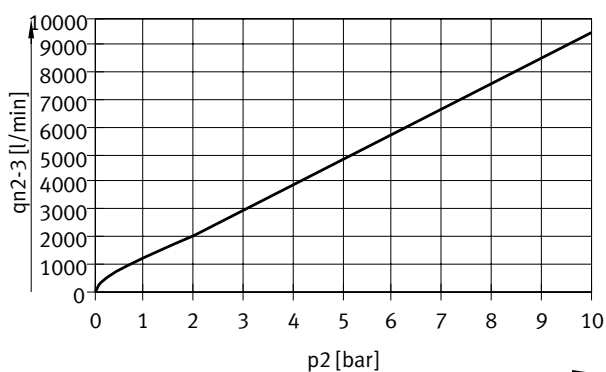

Product range overview

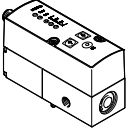
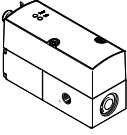
Function	Version	Design	Pneumatic port 1, 2, 3	Nominal width pressurisation/exhaust [mm]	Pressure regulation range		Setpoint value input			→ Page/ Internet
					[MPa]	[bar]	Voltage type	Current type	Digital	
Pressure regulators	Operator unit with LED (standard)									
		Piloted diaphragm valve	G1/8	6/4.5	0.002 ... 0.2 0.006 ... 0.6 0.01 ... 1	0.02 ... 2 0.06 ... 6 0.1 ... 10	■	■	–	18
			Sub-base	6/4.5	0.002 ... 0.2 0.006 ... 0.6 0.01 ... 1	0.02 ... 2 0.06 ... 6 0.1 ... 10	■	■	–	
				8/7	0.002 ... 0.2 0.006 ... 0.6 0.01 ... 1	0.02 ... 2 0.06 ... 6 0.1 ... 10	■	■	–	
			G1/4	8/7	0.002 ... 0.2 0.006 ... 0.6 0.01 ... 1	0.02 ... 2 0.06 ... 6 0.1 ... 10	■	■	–	
			G1/2	1 2/12	0.002 ... 0.2 0.006 ... 0.6 0.01 ... 1	0.02 ... 2 0.06 ... 6 0.1 ... 10	■	■	–	
	Operator unit with LED, for IO-Link									
		Piloted diaphragm valve	G1/8	6/4.5	0.002 ... 0.2 0.006 ... 0.6 0.01 ... 1	0.02 ... 2 0.06 ... 6 0.1 ... 10	–	–	■	26
			Sub-base	6/4.5	0.002 ... 0.2 0.006 ... 0.6 0.01 ... 1	0.02 ... 2 0.06 ... 6 0.1 ... 10	–	–	■	
				8/7	0.002 ... 0.2 0.006 ... 0.6 0.01 ... 1	0.02 ... 2 0.06 ... 6 0.1 ... 10	–	–	■	
			G1/4	8/7	0.002 ... 0.2 0.006 ... 0.6 0.01 ... 1	0.02 ... 2 0.06 ... 6 0.1 ... 10	–	–	■	
			G1/2	1 2/12	0.002 ... 0.2 0.006 ... 0.6 0.01 ... 1	0.02 ... 2 0.06 ... 6 0.1 ... 10	–	–	■	

Product range overview

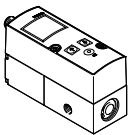
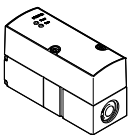
Function	Version	Design	Pneumatic port 1, 2, 3	Nominal width pressurisation/exhaust [mm]	Pressure regulation range [MPa] [bar]		Setpoint value input			→ Page/ Internet
							Voltage type 0 ... 10 V	Current type 4 ... 20 mA	Digital -	
Pressure regulators	Operator unit with LCD, pressure unit variable									
		Piloted diaphragm valve	G1/8	6/4.5	0.002 ... 0.2 0.006 ... 0.6 0.01 ... 1	0.02 ... 2 0.06 ... 6 0.1 ... 10	■	■	-	18
			Sub-base	6/4.5	0.002 ... 0.2 0.006 ... 0.6 0.01 ... 1	0.02 ... 2 0.06 ... 6 0.1 ... 10	■	■	-	
				8/7	0.002 ... 0.2 0.006 ... 0.6 0.01 ... 1	0.02 ... 2 0.06 ... 6 0.1 ... 10	■	■	-	
			G1/4	8/7	0.002 ... 0.2 0.006 ... 0.6 0.01 ... 1	0.02 ... 2 0.06 ... 6 0.1 ... 10	■	■	-	
			G1/2	1 2/12	0.002 ... 0.2 0.006 ... 0.6 0.01 ... 1	0.02 ... 2 0.06 ... 6 0.1 ... 10	■	■	-	
	Operator unit with LED, for valve terminal MPA-S									
		Piloted diaphragm valve	Sub-base MPA	6/4.5, 8/7	0.002 ... 0.2 0.006 ... 0.6 0.01 ... 1	0.02 ... 2 0.06 ... 6 0.1 ... 10	-	-	■	mpas

Peripherals overview

Individual valve VPPM-6L ... , VPPM-8L ...

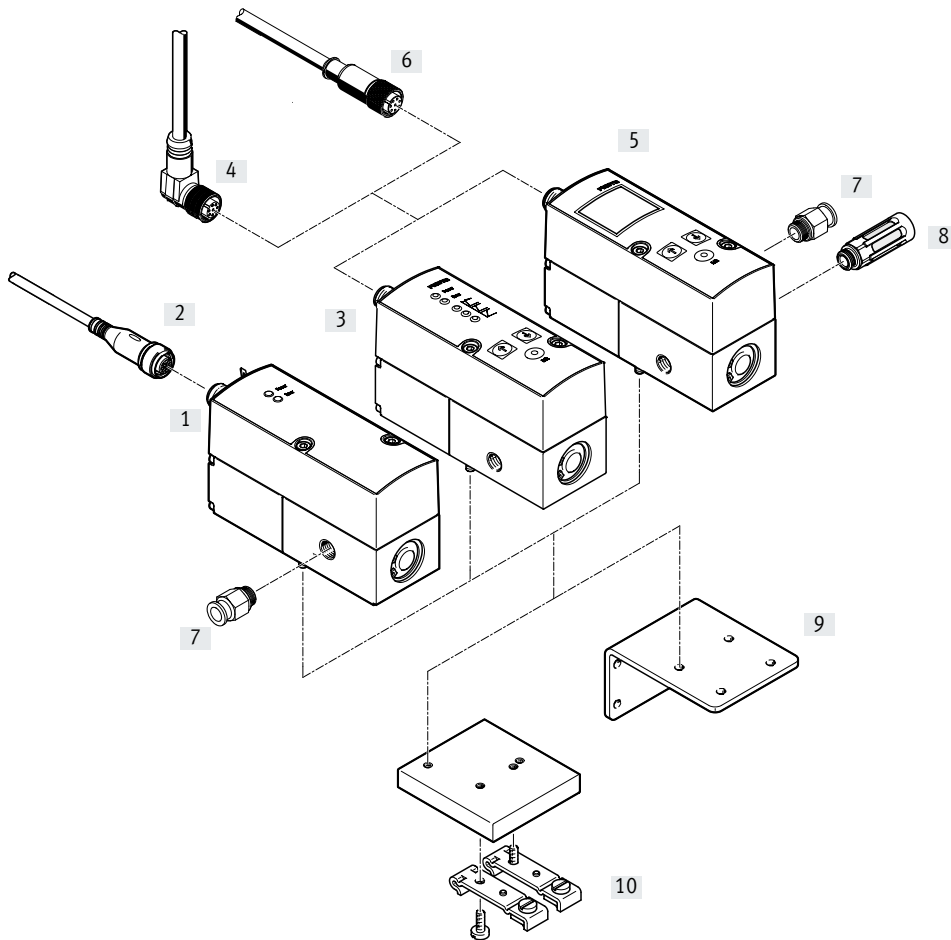

Accessories		Description	→ Page/Internet
[1]	Proportional-pressure regulator VPPM	Operator unit with LED, IO-Link	26
[2]	Connecting cable NEBU-M12G5...	–	41
[3]	Proportional-pressure regulator VPPM	Operator unit with LED	40
[4]	Plug socket with cable, angled NEBU-M12W8-...	–	40
[5]	Proportional-pressure regulator VPPM	Operator unit with LCD	18
[6]	Straight plug socket with cable SIM-M12-8GD-...	–	18
[7]	Push-in fitting QS	For connecting tubing with standard O.D.	qs
[8]	Silencer	For fitting in exhaust ports	u
[9]	Bracket VAME-P1-A	For mounting the valve	37
[10]	H-rail mounting VAME-P1-T	For mounting on an H-rail	38

Peripherals overview

Individual valve VPPM-12L ...

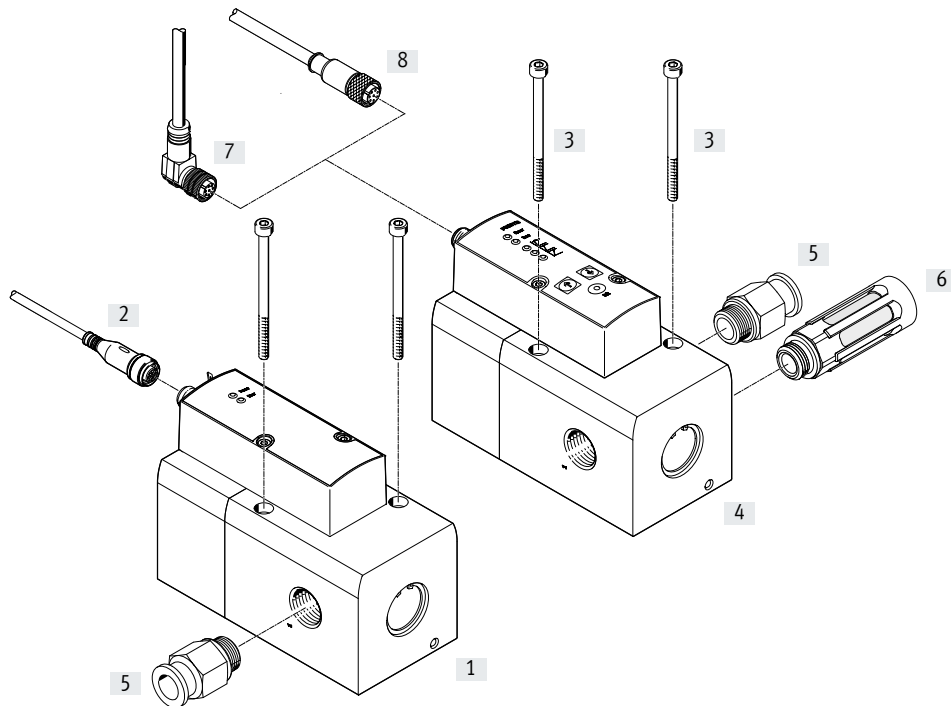

Accessories		Description	→ Page/Internet
[1]	Proportional-pressure regulator VPPM	Operator unit with LED, IO-Link	26
[2]	Connecting cable NEBU-M12G5-...	-	41
[3]	Retaining screws	-	-
[4]	Proportional-pressure regulator VPPM	Operator unit with LED or LCD	18
[5]	Push-in fitting QS	For connecting tubing with standard O.D.	qs
[6]	Silencer	For fitting in exhaust ports	u
[7]	Angled plug socket with cable NEBU-M12W8-...	-	40
[8]	Straight plug socket with cable SIM-M12-8GD-...	-	40

Peripherals overview

Valve manifold assembly with VPPM-6F ... , VPPM-8F ...

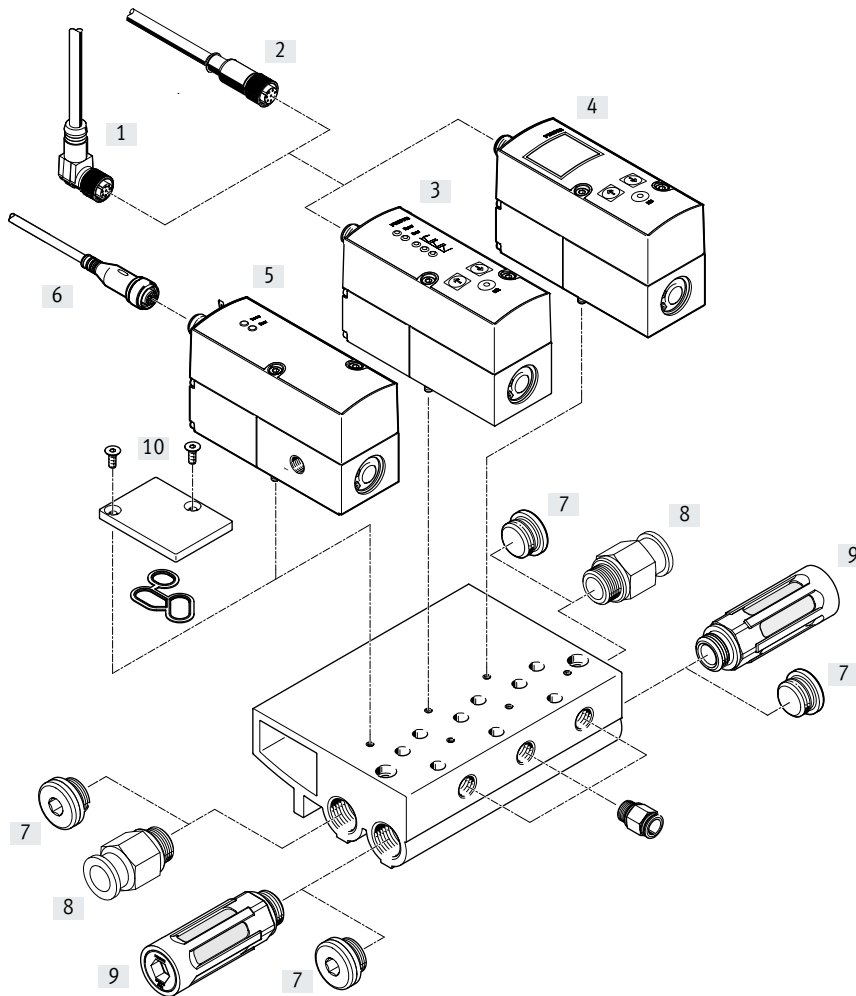

Accessories		Description	→ Page/Internet
[1]	Angled plug socket with cable NEBU-M12W8-...	-	40
[2]	Straight plug socket with cable SIM-M12-8GD-...	-	40
[3]	Proportional-pressure regulator VPPM	Operator unit with LED	18
[4]	Proportional-pressure regulator VPPM	Operator unit with LCD	18
[5]	Proportional-pressure regulator VPPM	Operator unit with LED, IO-Link	26
[6]	Connecting cable NEBU-M12G5-...	-	41
[7]	Blanking plug B	-	b
[8]	Push-in fitting QS	For connecting tubing with standard O.D.	qs
[9]	Silencer	For fitting in exhaust ports	u
[10]	Cover plate VABB-P1	For vacant position; seal and countersunk screws included in the scope of delivery	36
	Manifold block VABM	-	35

System overview

VPPM-6TA ... , VPPM-8TA ... for valve terminal MPA-S

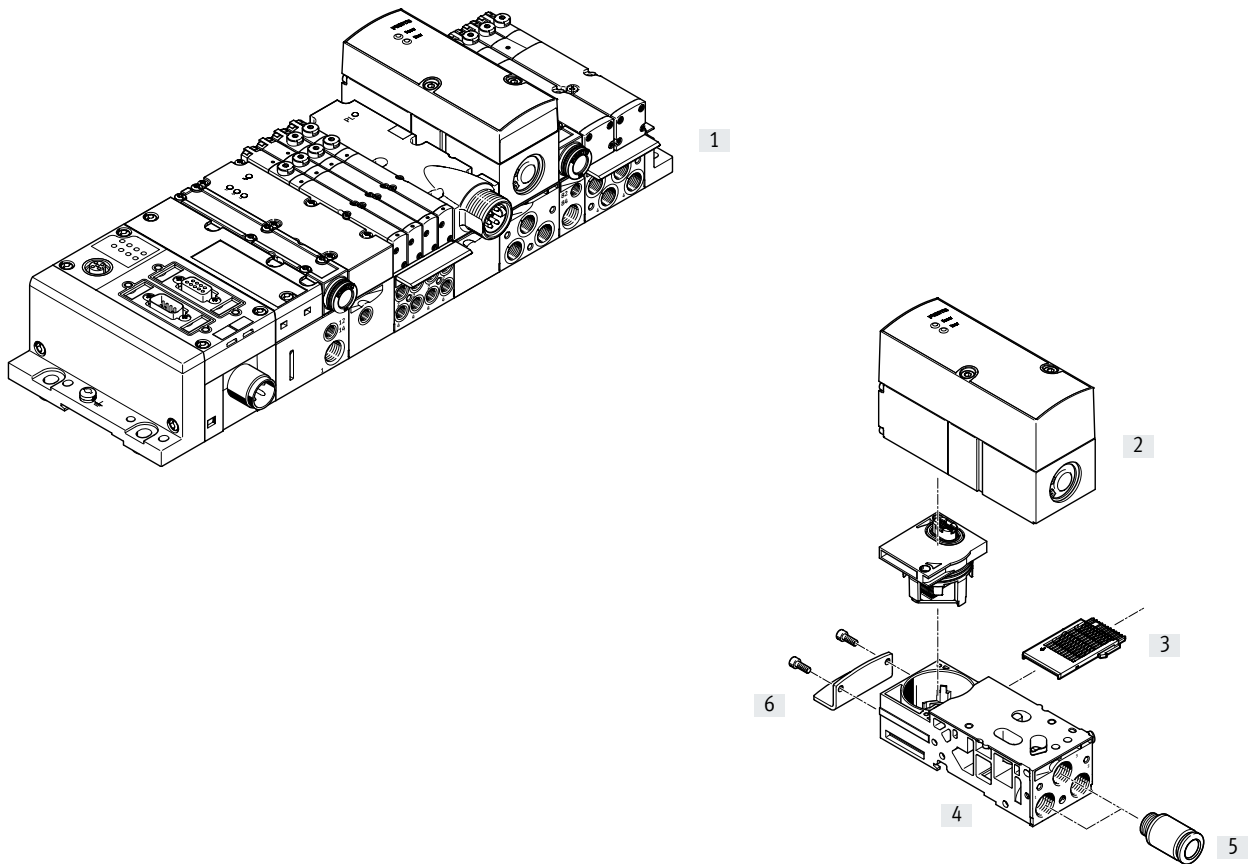



Accessories		Description	→ Page/Internet
[1]	Valve terminal MPA-S	With fieldbus interface and VPPM	mpas
[2]	Proportional-pressure regulator VPPM	For valve terminal MPA-S	mpas
[3]	Electrical linking module VMPA1-FB-EV-AB	For sub-base of the proportional-pressure regulator	mpas
[4]	Sub-base VMPA-FB-AP-P1	Without electrical linking module or electrical module	mpas
[5]	Push-in fitting QS	-	qs
[6]	Mounting VMPA-BG	-	mpas

Type codes

001	Series	
VPPM	Proportional pressure regulator, modular	
002	Nominal width [mm]	
6	6	
8	8	
12	12	
003	Directional control valve type	
L	In-line valve	
F	Flanged valve	
T	Flanged valve for valve terminal	
004	Mounting method	
	Standard	
A	Valve terminal MPA	
005	Dynamic response	
L	Low	
006	Valve function	
1	3/2-way valve, normally closed	
007	Pneumatic connection	
G18	G1/8	
G14	G1/4	
G12	G1/2	
F	Flange/sub-base	
008	Lower pressure value of control range	
0L	0 bar	

009	Upper pressure value of control range	
2H	2 bar	
6H	6 bar	
10H	10 bar	
010	Alternative lower pressure regulation range	
...L	0 ... 9 bar	
011	Alternative upper pressure regulation range	
...H	0.2 ... 10 bar	
012	Setpoint input for individual valves	
	For valve terminals/servo-pneumatics	
V1	0 ... 10 V	
LK	IO-Link®	
A4	4 ... 20 mA	
013	Switching input/output	
	None	
N	NPN	
P	PNP	
014	Overall accuracy	
	2%	
S1	1%	
015	Operator unit/interface	
	None	
C1	With LCD, variable pressure unit	

Datasheet – VPPM with analogue interface

-  Flow rate
380 ... 7000 l/min
-  Voltage
21.6 ... 26.4 V DC
-  Pressure regulation range
0.002 ... 1 MPa
0.02 ... 10 bar

- Variants
- Setpoint input as analogue voltage signal 0 ... 10 V
 - Setpoint input as analogue current signal 4 ... 20 mA
 - LED version
 - With LCD display (... C1)
 - Switching output NPN (N) or PNP (P)



General technical data			VPPM-6	VPPM-8	VPPM-12	Sub-base	
Type							
Pneumatic port			G1/8	G1/4	G1/2	Via sub-base	
Valve function			3-way proportional-pressure regulator				
Design			Piloted diaphragm regulator				
Sealing principle			Soft				
Actuation type			Electrical				
Type of control			Piloted				
Reset method			Mechanical spring				
Type of mounting			Via through-hole, via accessories				
Mounting position			Any				
Nominal width	Pressurisation	[mm]	6	8	12	6	8
	Exhaust port	[mm]	4.5	7	12	4.5	7
Standard nominal flow rate		[l/min]	→ Graphs				
Product weight		[g]	400	560	2050	400	560

Electrical data			VPPM-6	VPPM-8	VPPM-12
Type					
Electrical connection			Plug, round design, 8-pin, M12		
Operating voltage range		[V DC]	24 ± 10% = 21.6 ... 26.4		
Residual ripple		[%]	10		
Duty cycle		[%]	100		
Max. electrical power consumption		[W]	7	7	12
Setpoint input signal	Voltage	[V DC]	0 ... 10		
	Current	[mA]	4 ... 20		
Short circuit current rating			For all electrical connections		
Reverse polarity protection			For all electrical connections		
Degree of protection			IP65		

 **Note**
Output pressure will be unregulated if the power supply cable is interrupted.

Datasheet – VPPM with analogue interface

Operating and environmental conditions				
Pressure regulation range	[MPa]	0.002 ... 0.2	0.006 ... 0.6	0.01 ... 1
	[bar]	0.02 ... 2	0.06 ... 6	0.1 ... 10
Operating medium	Compressed air to ISO 8573-1:2010 [7:4:4] Inert gases			
Note on the operating/pilot medium	Lubricated operation not possible			
Input pressure 1 ¹⁾	[MPa]	0 ... 0.4	0 ... 0.8	0 ... 1.1
	[bar]	0 ... 4	0 ... 8	0 ... 11
Max. pressure hysteresis	[mbar]	10	30	50
Hysteresis	[%]	0.5 FS		
Linearity	[%]	1 FS		
Linearity error FS (full scale)	[%]	2		
Reproducibility	[%]	0.5 FS		
Overall accuracy	[%]	1.25 FS		
Repetition accuracy FS (full scale)	[%]	0.5		
Temperature coefficient	[%/K]	0.04		
Ambient temperature, operator unit LED (standard)	[°C]	0 ... 60		
Ambient temperature, operator unit with LCD	[°C]	0 ... 50		
Temperature of medium	[°C]	10 ... 50		
Note on materials	RoHS-compliant			
PWIS conformity	VDMA24364-B1/B2-L			
Corrosion resistance class	[CRC]	2 ²⁾		
CE marking (see declaration of conformity)	To EU EMC Directive (see declaration of conformity) ³⁾			
	To EU RoHS Directive ³⁾			
UKCA marking (see declaration of conformity)	To UK instructions for EMC ³⁾			
	To UK RoHS instructions ³⁾			
Certification	RCM			
	c UL us listed (OL)			
Certificate-issuing authority	UL E322346			

1) Input pressure 1 should always be 1 bar greater than the maximum regulated output pressure.

2) Corrosion resistance class CRC 2 to Festo standard FN 940070

Moderate corrosion stress. Indoor applications in which condensation can occur. External visible parts with primarily decorative surface requirements which are in direct contact with a normal industrial environment.

3) For information about the area of use, see the EC declaration of conformity at: www.festo.com/catalogue/... → Support/Downloads.

If the devices are subject to usage restrictions in residential, commercial or light-industrial environments, further measures for the reduction of the emitted interference may be necessary.

Datasheet – VPPM with analogue interface

Materials

Sectional view VPPM-6 ..., VPPM-8 ...

Sectional view VPPM-12 ...

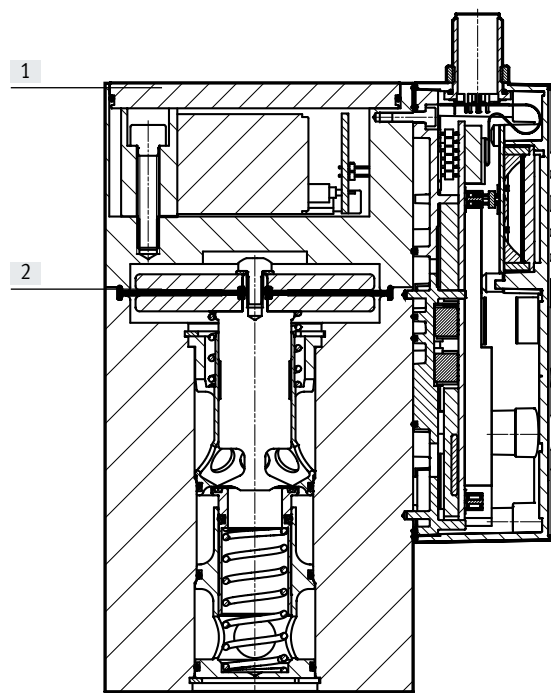
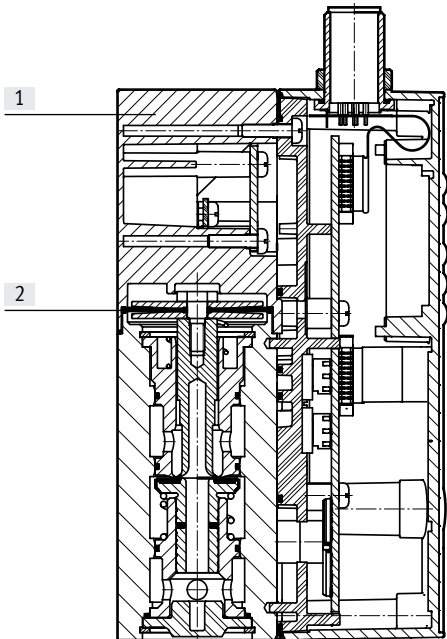

[1]	Housing	Wrought aluminium alloy
[2]	Diaphragm	Nitrile rubber

Datasheet – VPPM with analogue interface

Pin allocation M12, electrical connection

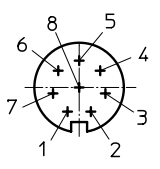
	Pin	Function
	1	Digital input D1
	2	+24 V DC supply voltage
	3	Analogue input W-
	4	Analogue input W+
	5	Digital input D2
	6	Analogue output X
	7	0 V DC or GND
	8	Digital output D3

Version

Circuit symbol

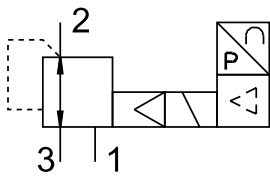

- Piloted diaphragm valve
- Pressure regulation range:
0.002 ... 0.2, 0.006 ... 0.6,
0.01 ... 1 MPa
- Signal setpoint value input:
0 ... 10 V DC, 4 ... 20 mA

Datasheet – VPPM with analogue interface

Dimensions

VPPM-6F, sub-base valve

Download CAD data → www.festo.com
with LCD

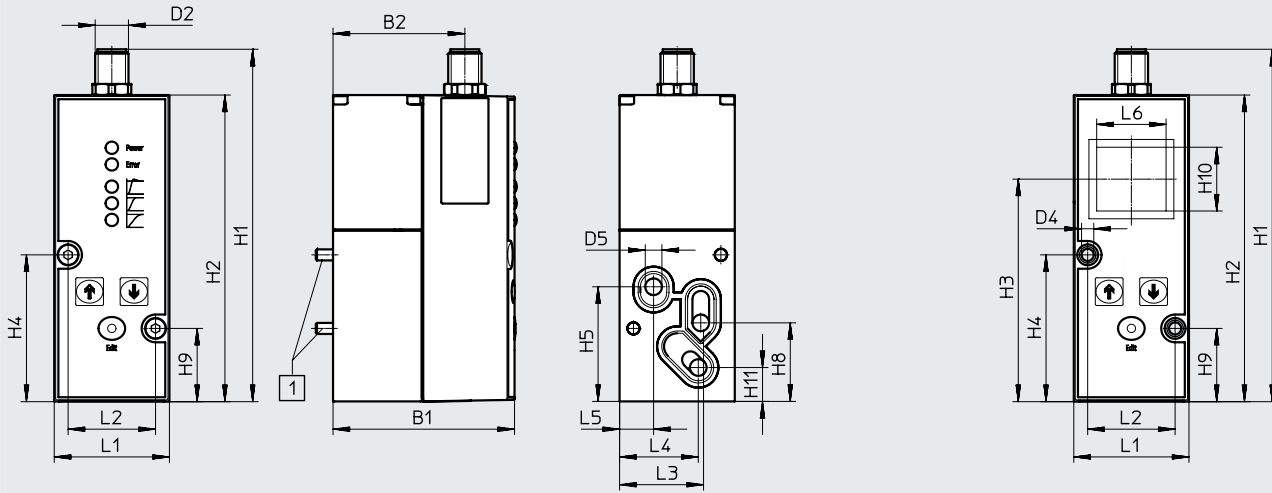

[1] Socket head screw M4x65

Type	B1	B2	D2 ∅	D4 ∅	D5 ∅	H1	H2	H3	H4	H5	H8	H9	H10	H11
VPPM-6F	65.4	47.5	M12x1	4.4	6	126.9	110.4	80.1	52.8	41.3	28.3	26.3	23	12.2

Type	L1	L2	L3	L4	L5	L6
VPPM-6F	41.5	31.5	30.3	28.4	12.3	25

Dimensions

VPPM-6L, pneumatic port G1/8

Download CAD data → www.festo.com
with LCD

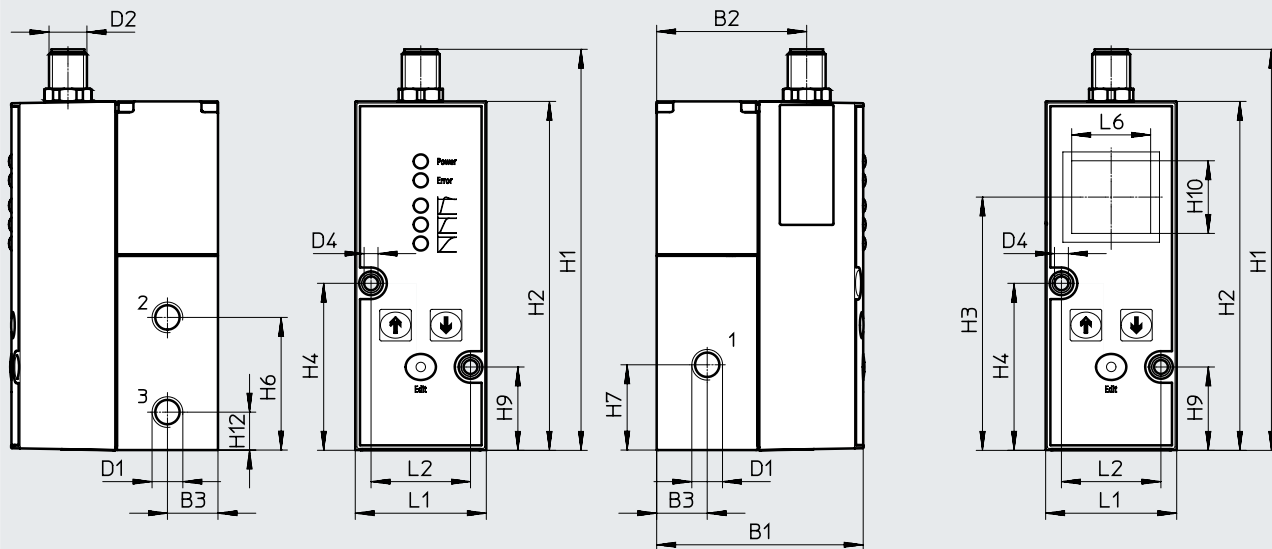

Type	B1	B2	B3	D1 ∅	D2 ∅	D4 ∅	H1	H2	H3	H4	H6	H7	H9	H10	H12
VPPM-6L	65.5	47.5	16	G1/8	M12x1	4.4	126.9	110.4	80.1	52.8	42	27	26.3	23	12

Type	L1	L2	L6
VPPM-6L	41.5	31.5	25

Datasheet – VPPM with analogue interface

Dimensions

VPPM-8F, sub-base valve

Download CAD data → www.festo.com
with LCD

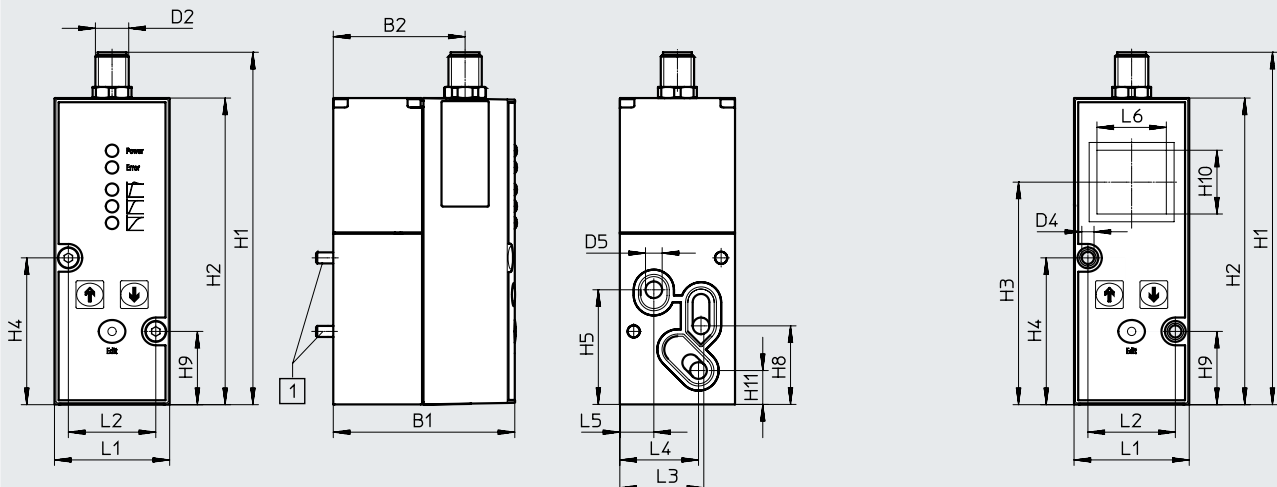

[1] Socket head screw M4x77

Type	B1	B2	D2	D5 ∅	H1	H2	H3	H4	H5	H8	H9	H10	H11
VPPM-8F	77.4	59.5	M12x1	8	126.9	110.4	80	52.8	41.3	28.3	26.3	23	12.2

Type	L1	L2	L3	L4	L5	L6
VPPM-8F	41.5	31.5	29.3	28.4	12.3	25

Dimensions

VPPM-8L, pneumatic port G1/4

Download CAD data → www.festo.com
with LCD

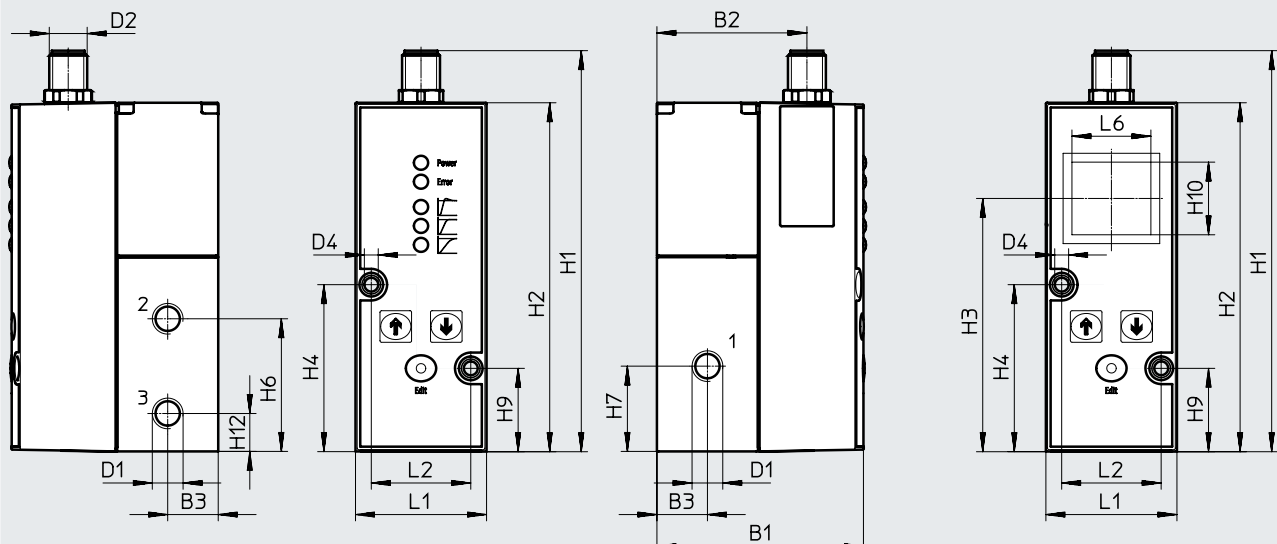

Type	B1	B2	B3	D1	D2	H1	H2	H3	H4	H6	H7	H9	H10	H12
VPPM-8L	77.4	59.5	22	G1/4	M12x1	126.9	110.4	80	52.8	42	27	26.3	23	12

Type	L1	L2	L6
VPPM-8L	47	31.5	25

Datasheet – VPPM with analogue interface

Dimensions

Download CAD data → www.festo.com

VPPM-6TA, sub-base valve

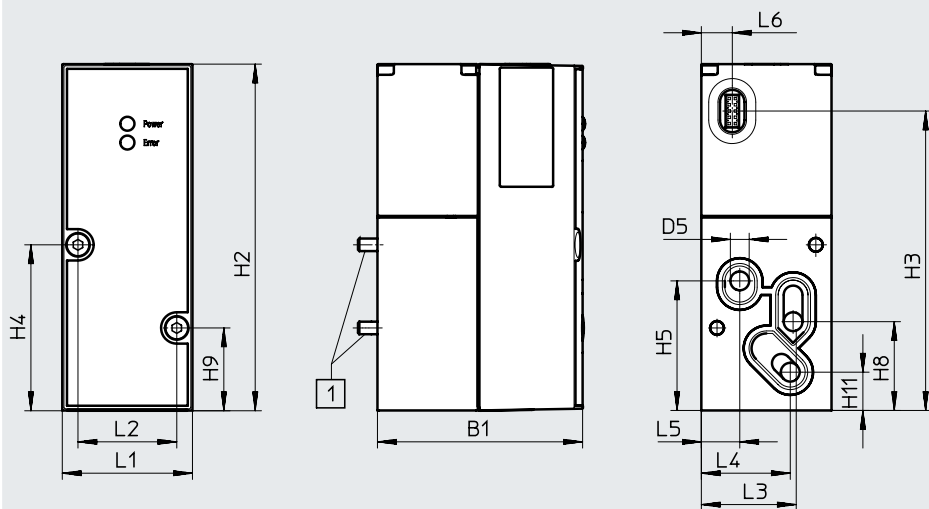

[1] Socket head screw M4x55

Type	B1	D5 ∅	H2	H3	H4	H5	H8	H9	H11
VPPM-6TA	55.1	6	110.4	95.5	52.8	41.3	28.3	26.3	12.2

Type	L1	L2	L3	L4	L5	L6
VPPM-6TA	41.5	31.5	30.3	28.4	12.3	9.9

Dimensions

Download CAD data → www.festo.com

VPPM-8TA, sub-base valve with LCD

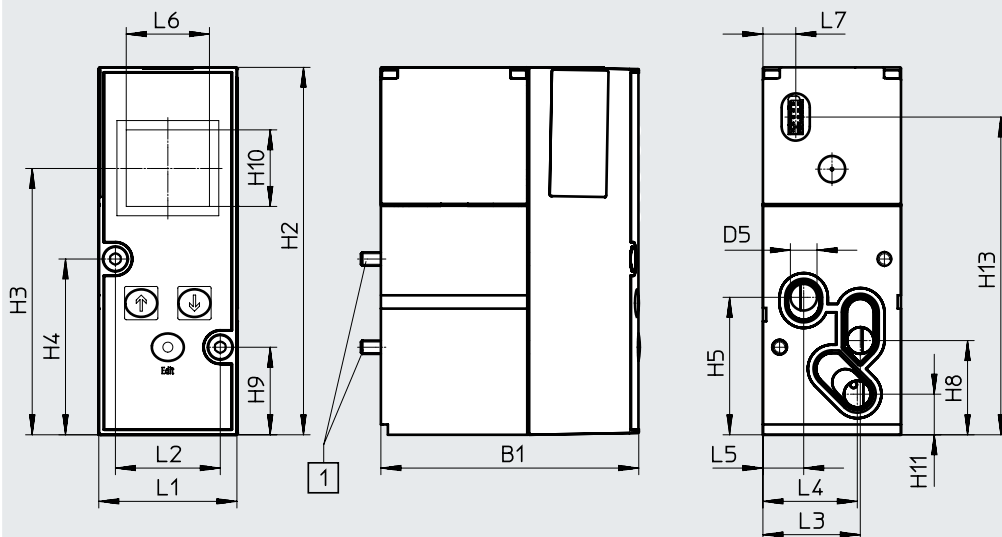

[1] Socket head screw M4x77

Type	B1	D5 ∅	H2	H3	H4	H5	H8	H9	H10	H11	H13
VPPM-8TA	77.4	8	110.4	80	52.8	41.3	28.3	26.3	23	12.2	95.5

Type	L1	L2	L3	L4	L5	L6	L7
VPPM-8TA	41.5	31.5	29.3	28.4	12.3	25	9.9

Datasheet – VPPM with analogue interface

Dimensions

VPPM-12L, pneumatic port G1/2

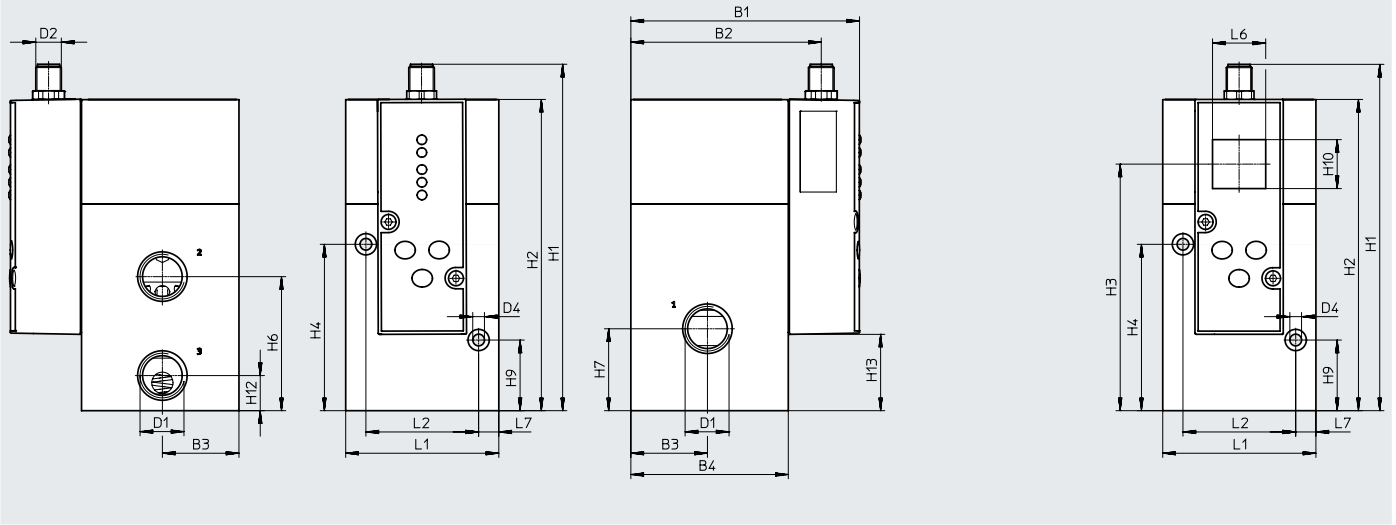

Download CAD data → www.festo.com
with LCD



Type	B1	B2	B3	B4	D1	D2	D4 ∅	H1	H2	H3	H4	H6	H7	H9	H10	H12	H13
VPPM-12L	107.4	89.5	36	74	G1/2	M12x1	5.5	162.8	146.3	116	78.2	63	38.5	33.2	23	16.5	35.9

Type	L1	L2	L6	L7
VPPM-12L	72	53	25	9.5

Datasheet – VPPM with IO-Link interface

-  Flow rate
380 ... 7000 l/min
 -  Voltage
18 ... 30 V DC
 -  Pressure regulation range
0.002 ... 1 MPa
0.02 ... 10 bar
- Digital setpoint and actual value transfer
 - For connection to an I/O-Link/I-Port master
 - LED version
 - Comparator output (digital)



General technical data			VPPM-6	VPPM-8	VPPM-12	Sub-base	
Pneumatic port			G1/8	G1/4	G1/2	Via sub-base	
Valve function			3-way proportional-pressure regulator				
Design			Piloted diaphragm regulator				
Display type			LED				
Sealing principle			Soft				
Actuation type			Electrical				
Type of control			Piloted				
Reset method			Mechanical spring				
Type of mounting			Via through-hole, via accessories				
Mounting position			Any				
Nominal width	Pressurisation	[mm]	6	8	12	6	8
	Exhaust port	[mm]	4.5	7	12	4.5	7
Standard nominal flow rate		[l/min]	→ Graphs				
Product weight		[g]	400	560	2050	400	560
IO-Link	Protocol		IO-Link, I-Port				
	Protocol version		Device V1.1				
	Port type		A				
	Process data width OUT	[byte]	2				
	Process data width IN	[byte]	2				
Communication mode	COM1	[kBaud]	4.8				
	COM2	[kBaud]	38.4				
	COM3	[kBaud]	230.4				
IO-Link	Minimum cycle time		[ms]	0.5			
Information on materials		Housing	Wrought aluminium alloy				

Electrical data			VPPM-6	VPPM-8	VPPM-12
Type			M12 plug connector, 5-pin		
Operating voltage range		[V DC]	18 ... 30		
Max. current consumption		[mA]	300	300	500
Max. electrical power consumption		[W]	7		
Short circuit current rating			For all electrical connections		
Reverse polarity protection			For all electrical connections		
Residual ripple		[%]	10		
Duty cycle		[%]	100		
Degree of protection			IP65		

-  **Note**
Output pressure will be unregulated if the power supply cable is interrupted.

Datasheet – VPPM with IO-Link interface

Operating and environmental conditions				
Pressure regulation range	[MPa]	0.002 ... 0.2	0.006 ... 0.6	0.01 ... 1
	[bar]	0.02 ... 2	0.06 ... 6	0.1 ... 10
Operating medium	Compressed air to ISO 8573-1:2010 [7:4:4] Inert gases			
Note on the operating/pilot medium	Lubricated operation not possible			
Input pressure 1 ¹⁾	[MPa]	0 ... 0.4	0 ... 0.8	0 ... 1.1
	[bar]	0 ... 4	0 ... 8	0 ... 11
Max. pressure hysteresis	[mbar]	10	30	50
Hysteresis	[%]	0.5 FS		
Linearity	[%]	1 FS		
Linearity error FS (full scale)	[%]	1		
Reproducibility	[%]	0.5 FS		
Overall accuracy	[%]	1.25 FS		
Repetition accuracy FS (full scale)	[%]	0.5		
Temperature coefficient	[%/K]	0.04		
Ambient temperature	[°C]	0 ... 60		
Temperature of medium	[°C]	10 ... 50		
Note on materials	RoHS-compliant			
PWIS conformity	VDMA24364-B1/B2-L			
Corrosion resistance class	[CRC]	2 ²⁾		
CE marking (see declaration of conformity)	To EU EMC Directive (see declaration of conformity) ³⁾			
	To EU RoHS Directive ³⁾			
UKCA marking (see declaration of conformity)	To UK instructions for EMC ³⁾			
	To UK RoHS instructions ³⁾			
Certification	RCM			
	c UL us listed (OL)			
Certificate-issuing authority	UL E322346			

1) Input pressure 1 should always be 1 bar greater than the maximum regulated output pressure.

2) Corrosion resistance class CRC 2 to Festo standard FN 940070

Moderate corrosion stress. Indoor applications in which condensation can occur. External visible parts with primarily decorative surface requirements which are in direct contact with a normal industrial environment.

3) For information about the area of use, see the EC declaration of conformity at: www.festo.com/catalogue/... → Support/Downloads.

If the devices are subject to usage restrictions in residential, commercial or light-industrial environments, further measures for the reduction of the emitted interference may be necessary.

Pin allocation of IO-Link interface

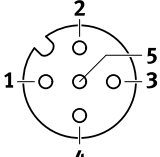
	Pin	Allocation	Function
	1	24 V DC ($U_{EL/SEN}$)	Operating voltage supply (PS)
	2	n.c.	Not connected
	3	0 V DC ($U_{EL/SEN}$)	Operating voltage supply (PS)
	4	C/Q I-Port	Data communication
	5	n.c.	Not connected
	–	FE	Functional earth

Version

Circuit symbol

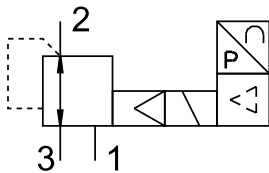

- Piloted diaphragm valve
- Pressure regulation range:
0.002 ... 0.2, 0.006 ... 0.6,
0.01 ... 1 MPa
- Signal setpoint value input:
0 ... 10 V DC, 4 ... 20 mA

Datasheet – VPPM with IO-Link interface

Dimensions

Download CAD data → www.festo.com

VPPM-6F, sub-base valve

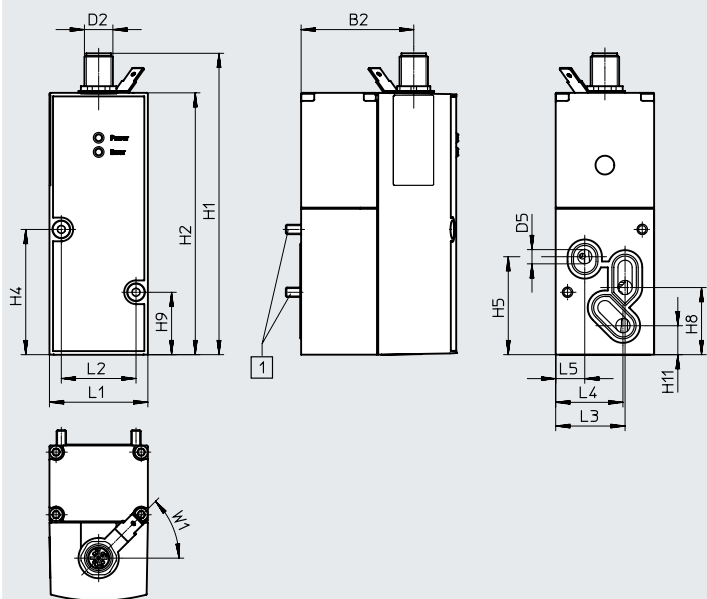

[1] Socket head screw M4x65

Type	B1	B2	D2 ∅	D5 ∅	H1	H2	H4	H5	H8	H9	H11
VPPM-6F	65.5	47.5	M12x1	6	126.9	110.4	52.8	41.3	28.3	26.3	12.2

Type	L1	L2	L3	L4	L5	W1 ± 5°
VPPM-6L	41.5	31.5	30.3	28.4	12.3	45°

Dimensions

Download CAD data → www.festo.com

VPPM-6L, pneumatic port G1/8

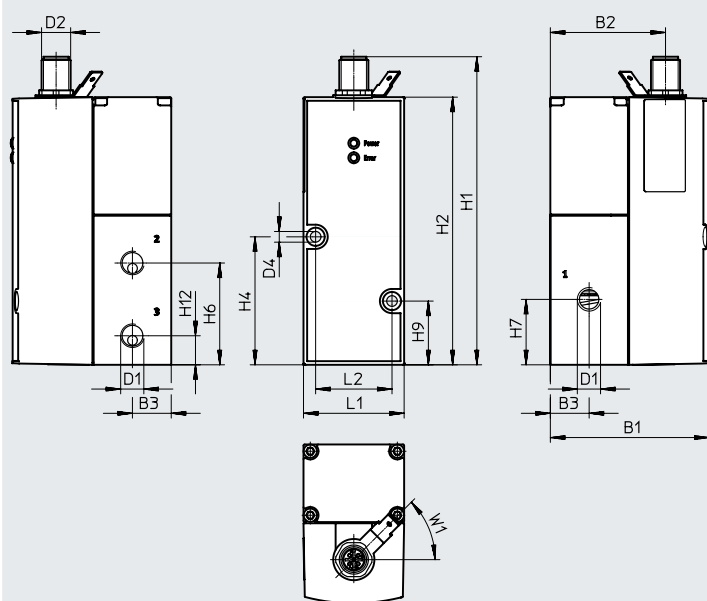

Type	B1	B2	B3	D1 ∅	D2 ∅	D4 ∅	H1	H2	H4	H6	H7	H9	H12
VPPM-6L	65.5	47.5	16	G1/8	M12x1	4.4	126.9	110.4	52.8	42	27	26.3	12

Type	L1	L2	W1 ± 5°
VPPM-6L	41.5	31.5	45°

Datasheet – VPPM with IO-Link interface

Dimensions

Download CAD data → www.festo.com

VPPM-8F, sub-base valve

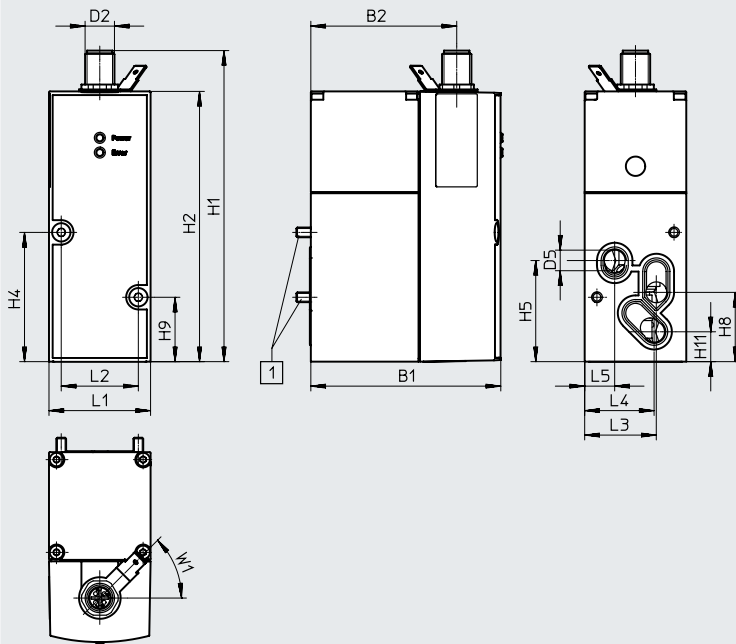

[1] Socket head screw M4x77

Type	B1	B2	D2	D5 ø	H1	H2	H4	H5	H8	H9	H11
VPPM-8L	77.4	59.5	M12x1	8	126.9	110.4	52.8	41.3	28.3	26.3	12.2

Type	L1	L2	L3	L4	L5	W1 ± 5°
VPPM-8L	41.5	31.5	29.3	28.4	12.3	45°

Dimensions

Download CAD data → www.festo.com

VPPM-8L, pneumatic port G1/4

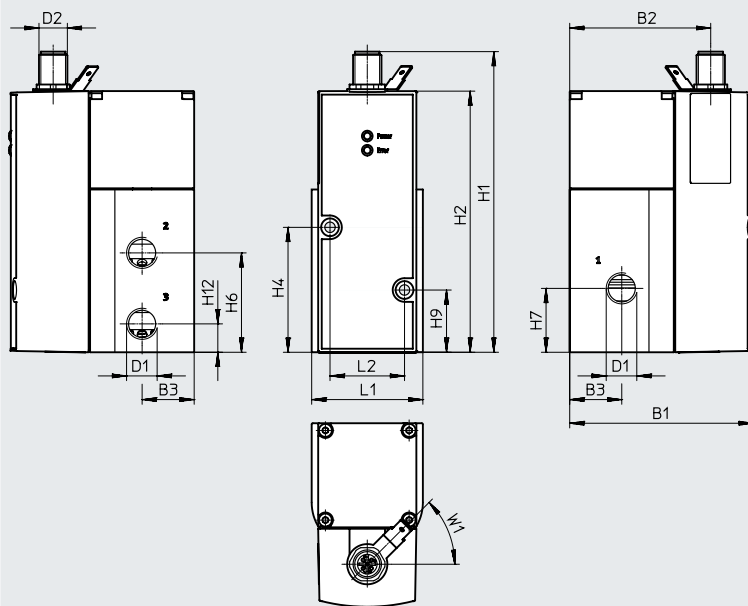

Type	B1	B2	B3	D1	D2	H1	H2	H4	H6	H7	H9	H12
VPPM-8L	77.4	59.5	22	G1/4	M12x1	126.9	110.4	52.8	42	27	26.3	12

Type	L1	L2	W1 ± 5°
VPPM-8L	47	31.5	45°

Datasheet – VPPM with IO-Link interface

Dimensions

Download CAD data → www.festo.com

VPPM-12L, pneumatic port G1/2

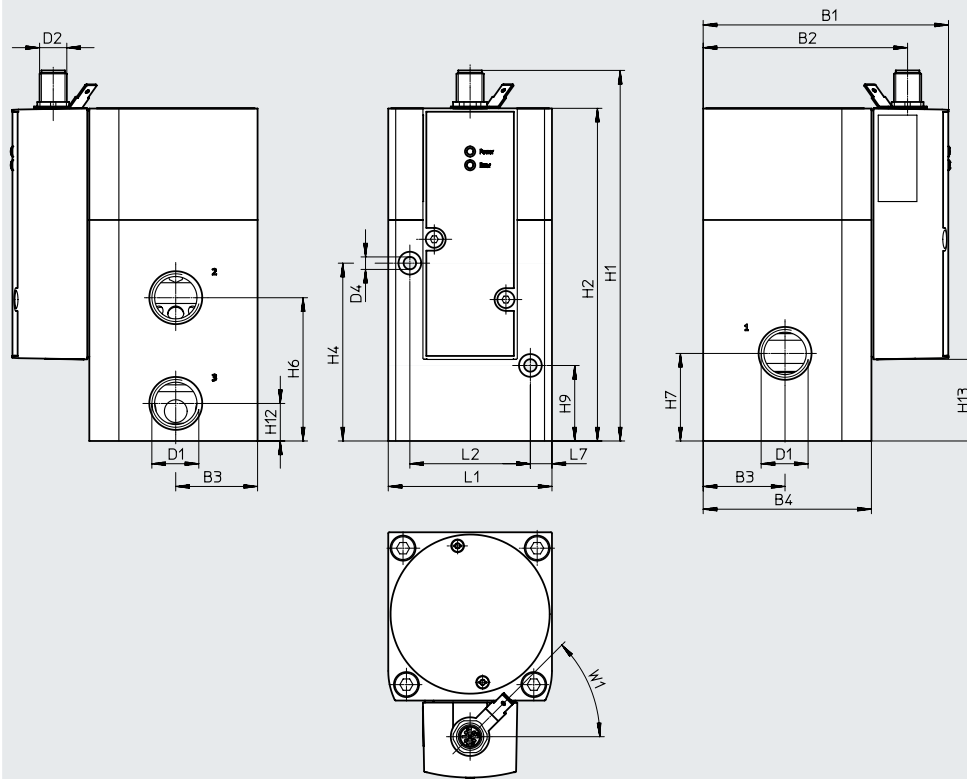

Type	B1	B2	B3	B4	D1	D2	D4 ø	H1	H2	H4	H6	H7	H9	H12	H13
VPPM-12L	107.4	89.5	36	74	G1/2	M12x1	4.4	162.8	146.3	78.2	63	38.5	33.2	16.5	35.9

Type	L1	L2	L7	W1 ±5°
VPPM-12L	72	53	9.5	45°

Datasheet

Ordering data		Pneumatic port		Pressure regulation range		Part no.	Type	
VPPM with analogue interface		1, 2, 3		[MPa]	[bar]			
Voltage type 0 ... 10 V								
Overall accuracy 2%	G1/8	0.002 ... 0.2	0.02 ... 2	542233	VPPM-6L-L-1-G18-0L2H-V1N			
		0.006 ... 0.6	0.06 ... 6	542234	VPPM-6L-L-1-G18-0L6H-V1N			
				554043	VPPM-6L-L-1-G18-0L6H-V1P			
				558337	VPPM-6L-L-1-G18-0L6H-V1P-C1			
	558346	VPPM-6L-L-1-G18-0L6H-V1N-C1						
		G1/8	0.01 ... 1	0.1 ... 10	575125	VPPM-6L-L-1-G18-0L10H-V1P-C1		
					542235	VPPM-6L-L-1-G18-0L10H-V1N		
	554044				VPPM-6L-L-1-G18-0L10H-V1P			
	Sub-base	0.002 ... 0.2	0.02 ... 2	542245	VPPM-6F-L-1-F-0L2H-V1N			
				542246	VPPM-6F-L-1-F-0L6H-V1N			
		0.006 ... 0.6	0.06 ... 6	558339	VPPM-6F-L-1-F-0L6H-V1P-C1			
				558347	VPPM-6F-L-1-F-0L6H-V1N-C1			
	571285	VPPM-8F-L-1-F-0L6H-V1P						
		0.01 ... 1	0.1 ... 10	542247	VPPM-6F-L-1-F-0L10H-V1N			
	G1/4	0.006 ... 0.6	0.06 ... 6	571296	VPPM-8L-L-1-G14-0L6H-V1P			
	Overall accuracy 1%	G1/8	0.002 ... 0.2	0.02 ... 2	542227	VPPM-6L-L-1-G18-0L2H-V1N-S1		
					542228	VPPM-6L-L-1-G18-0L6H-V1N-S1		
			0.006 ... 0.6	0.06 ... 6	554039	VPPM-6L-L-1-G18-0L6H-V1P-S1		
571448					VPPM-6L-L-1-G18-0L6H-V1N-S1C1			
575121					VPPM-6L-L-1-G18-0L6H-V1P-S1C1			
542229					VPPM-6L-L-1-G18-0L10H-V1N-S1			
0.01 ... 1			0.1 ... 10	554040	VPPM-6L-L-1-G18-0L10H-V1P-S1			
				558335	VPPM-6L-L-1-G18-0L10H-V1P-S1C1			
				558345	VPPM-6L-L-1-G18-0L10H-V1N-S1C1			
				Sub-base	0.002 ... 0.2	0.02 ... 2	542239	VPPM-6F-L-1-F-0L2H-V1N-S1
542240		VPPM-6F-L-1-F-0L6H-V1N-S1						
0.006 ... 0.6		0.06 ... 6	571286		VPPM-8F-L-1-F-0L6H-V1P-S1			
			571287	VPPM-8F-L-1-F-0L6H-V1P-S1C1				
0.01 ... 1		0.1 ... 10	542241	VPPM-6F-L-1-F-0L10H-V1N-S1				
			G1/4	0.01 ... 1	0.1 ... 10	571291	VPPM-8L-L-1-G14-0L10H-V1N-S1	
571292		VPPM-8L-L-1-G14-0L10H-V1P-S1						
571293		VPPM-8L-L-1-G14-0L10H-V1P-S1C1						
0.006 ... 0.6		0.06 ... 6		571294	VPPM-8L-L-1-G14-0L6H-V1N-S1			
				571295	VPPM-8L-L-1-G14-0L6H-V1N-S1C1			
				571297	VPPM-8L-L-1-G14-0L6H-V1P-S1			
				571298	VPPM-8L-L-1-G14-0L6H-V1P-S1C1			
G1/2		0.01 ... 1		0.1 ... 10	575235	VPPM-12L-L-1-G12-0L10H-V1N-S1		
			575236		VPPM-12L-L-1-G12-0L10H-V1P-S1			
			575237		VPPM-12L-L-1-G12-0L10H-V1P-S1C1			
		0.006 ... 0.6	0.06 ... 6	575238	VPPM-12L-L-1-G12-0L6H-V1N-S1			
				575239	VPPM-12L-L-1-G12-0L6H-V1N-S1C1			
				575240	VPPM-12L-L-1-G12-0L6H-V1P-S1			
575241		VPPM-12L-L-1-G12-0L6H-V1P-S1C1						

Datasheet

Ordering data								
VPPM with analogue interface	Pneumatic port 1, 2, 3	Pressure regulation range		Part no.	Type			
		[MPa]	[bar]					
Current type 4 ... 20 mA								
Overall accuracy 2%	G1/8	0.002 ... 0.2	0.02 ... 2	542236	VPPM-6L-L-1-G18-0L2H-A4N			
				0.006 ... 0.6	0.06 ... 6	542237	VPPM-6L-L-1-G18-0L6H-A4N	
						554045	VPPM-6L-L-1-G18-0L6H-A4P	
		0.01 ... 1	0.1 ... 10	542238	VPPM-6L-L-1-G18-0L10H-A4N			
				554046	VPPM-6L-L-1-G18-0L10H-A4P			
		Sub-base	0.002 ... 0.2	0.02 ... 2	542248	VPPM-6F-L-1-F-0L2H-A4N		
	542249				VPPM-6F-L-1-F-0L6H-A4N			
	0.006 ... 0.6		0.06 ... 6	558340	VPPM-6F-L-1-F-0L6H-A4P-C1			
				571282	VPPM-8F-L-1-F-0L6H-A4P			
	0.01 ... 1	0.1 ... 10	542250	VPPM-6F-L-1-F-0L10H-A4N				
			571299	VPPM-8L-L-1-G14-0L6H-A4P				
	Overall accuracy 1%	G1/8	0.002 ... 0.2	0.02 ... 2	542230	VPPM-6L-L-1-G18-0L2H-A4N-S1		
					0.006 ... 0.6	0.06 ... 6	542231	VPPM-6L-L-1-G18-0L6H-A4N-S1
							554041	VPPM-6L-L-1-G18-0L6H-A4P-S1
0.01 ... 1			0.1 ... 10	575128	VPPM-6L-L-1-G18-0L6H-A4P-S1C1			
				542232	VPPM-6L-L-1-G18-0L10H-A4N-S1			
0.006 ... 0.6			0.06 ... 6	554042	VPPM-6L-L-1-G18-0L10H-A4P-S1			
				558336	VPPM-6L-L-1-G18-0L10H-A4P-S1C1			
				542242	VPPM-6F-L-1-F-0L2H-A4N-S1			
Sub-base			0.002 ... 0.2	0.02 ... 2	542243	VPPM-6F-L-1-F-0L6H-A4N-S1		
					571283	VPPM-8F-L-1-F-0L6H-A4P-S1		
			0.006 ... 0.6	0.06 ... 6	571284	VPPM-8F-L-1-F-0L6H-A4P-S1C1		
					542244	VPPM-6F-L-1-F-0L10H-A4N-S1		
0.01 ... 1		0.1 ... 10	571288	VPPM-8L-L-1-G14-0L10H-A4N-S1				
			571289	VPPM-8L-L-1-G14-0L10H-A4P-S1				
G1/4		0.006 ... 0.6	0.06 ... 6	571290	VPPM-8L-L-1-G14-0L10H-A4P-S1C1			
				571302	VPPM-8L-L-1-G14-0L6H-A4N-S1			
				571303	VPPM-8L-L-1-G14-0L6H-A4N-S1C1			
		0.01 ... 1	0.1 ... 10	571300	VPPM-8L-L-1-G14-0L6H-A4P-S1			
				571301	VPPM-8L-L-1-G14-0L6H-A4P-S1C1			
		G1/2	0.01 ... 1	0.1 ... 10	575232	VPPM-12L-L-1-G12-0L10H-A4N-S1		
575233					VPPM-12L-L-1-G12-0L10H-A4P-S1			
575234					VPPM-12L-L-1-G12-0L10H-A4P-S1C1			
0.006 ... 0.6			0.06 ... 6	575242	VPPM-12L-L-1-G12-0L6H-A4P-S1			
				575243	VPPM-12L-L-1-G12-0L6H-A4P-S1C1			
				575244	VPPM-12L-L-1-G12-0L6H-A4N-S1			
575245		VPPM-12L-L-1-G12-0L6H-A4N-S1C1						
For valve terminal								
Overall accuracy 2%		Via valve terminal	0.002 ... 0.2	0.02 ... 2	542220	VPPM-6TA-L-1-F-0L2H		
					0.006 ... 0.6	0.06 ... 6	572410	VPPM-8TA-L-1-F-0L2H-C1
							542221	VPPM-6TA-L-1-F-0L6H
	0.002 ... 0.2		0.02 ... 10	572411	VPPM-8TA-L-1-F-0L6H-C1			
				542222	VPPM-6TA-L-1-F-0L10H			
	572412		VPPM-8TA-L-1-F-0L10H-C1					
Overall accuracy 1%	Via valve terminal	0.002 ... 0.2	0.02 ... 2	542217	VPPM-6TA-L-1-F-0L2H-S1			
				572407	VPPM-8TA-L-1-F-0L2H-S1C1			
		0.006 ... 0.6	0.06 ... 6	542218	VPPM-6TA-L-1-F-0L6H-S1			
				572408	VPPM-8TA-L-1-F-0L6H-S1C1			
		0.002 ... 0.2	0.02 ... 10	542219	VPPM-6TA-L-1-F-0L10H-S1			
				572409	VPPM-8TA-L-1-F-0L10H-S1C1			

Datasheet

Ordering data VPPM with IO-Link interface	Pneumatic port 1, 2, 3	Pressure regulation range		Part no.	Type
		[MPa]	[bar]		
Overall accuracy 1%	G1/8	0.002 ... 0.2	0.02 ... 2	8024258	VPPM-6L-L-1-G18-0L2H-LK-S1
		0.006 ... 0.6	0.06 ... 6	8024259	VPPM-6L-L-1-G18-0L6H-LK-S1
		0.01 ... 1	0.1 ... 10	8024260	VPPM-6L-L-1-G18-0L10H-LK-S1
	Sub-base	0.002 ... 0.2	0.02 ... 2	8031107	VPPM-6F-L-1-F-0L2H-LK-S1
		0.006 ... 0.6	0.06 ... 6	8031108	VPPM-6F-L-1-F-0L6H-LK-S1
		0.01 ... 1	0.1 ... 10	8031109	VPPM-6F-L-1-F-0L10H-LK-S1
	G1/4	0.002 ... 0.2	0.02 ... 2	8024261	VPPM-8L-L-1-G14-0L2H-LK-S1
		0.006 ... 0.6	0.06 ... 6	8024262	VPPM-8L-L-1-G14-0L6H-LK-S1
		0.01 ... 1	0.1 ... 10	8024263	VPPM-8L-L-1-G14-0L10H-LK-S1
	Sub-base	0.002 ... 0.2	0.02 ... 2	8031110	VPPM-8F-L-1-F-0L2H-LK-S1
		0.006 ... 0.6	0.06 ... 6	8031111	VPPM-8F-L-1-F-0L6H-LK-S1
		0.01 ... 1	0.1 ... 10	8031112	VPPM-8F-L-1-F-0L10H-LK-S1
	G1/2	0.002 ... 0.2	0.02 ... 2	8024264	VPPM-12L-L-1-G12-0L2H-LK-S1
		0.006 ... 0.6	0.06 ... 6	8024265	VPPM-12L-L-1-G12-0L6H-LK-S1
		0.01 ... 1	0.1 ... 10	8024266	VPPM-12L-L-1-G12-0L10H-LK-S1

Ordering data – Modular product system

Ordering table		Conditions	Code	Enter code
Size	6			
Module no.	543432			
Design	Modular pressure regulator		VPPM	VPPM
Nominal width	6		-6	
	8		-8	
	12	[1]	-12	
Valve type	In-line	[2]	L	
	Flanged valve	[3]	F	
	Flanged valve for valve terminal	[4]	T	
Dynamic response	Low dynamic response (pilot-actuated, soft-sealing)		-L	-L
Valve operating mode	3/2-way valve, normally closed		-1	-1
Connection type	G thread G1/8		-G18	
	G thread G1/4		-G14	
	G thread G1/2		-G12	
	Flange/sub-base		-F	
Pressure regulation range	0 ... 2 bar		-OL2H	
	0 ... 6 bar		-OL6H	
	0 ... 10 bar		-OL10H	
Alternative lower pressure regulation range	0.1 ... 10 bar	[5]	...L	
Alternative upper pressure regulation range	0.1 ... 10 bar	[5]	...H	
Setpoint specification	Voltage (standard 0 ... 10 V)		-V1	
	IO-Link		-LK	
	Current (standard 4 ... 20 mA)		-A4	
Switching output	PNP - switching		P	
	NPN - switching		N	
Overall accuracy	1%		-S1	
Operator unit	with LCD, pressure unit, variable		C1	

- 1) 12 Only with valve type L (in-line)
- 2) L Only with connection type G18, G14, G12 (G thread G1/8, G1/4, G1/2)
- 3) F Only with connection type F (flange/sub-base)
- 4) T Only with connection type F (flange/sub-base)
- 5) ...L Not with pressure regulation range (OL2H, OL6H, OL10H).
Must always be less than alternative upper pressure regulation range H
- 5) ...H Not with pressure regulation range (OL2H, OL6H, OL10H).
Must always be greater than alternative upper pressure regulation range L

Accessories

Manifold block
VABM-P1

Material:
Wrought aluminium alloy

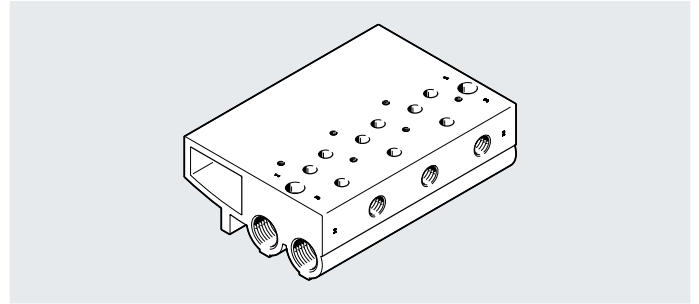

Dimensions

Download CAD data → www.festo.com

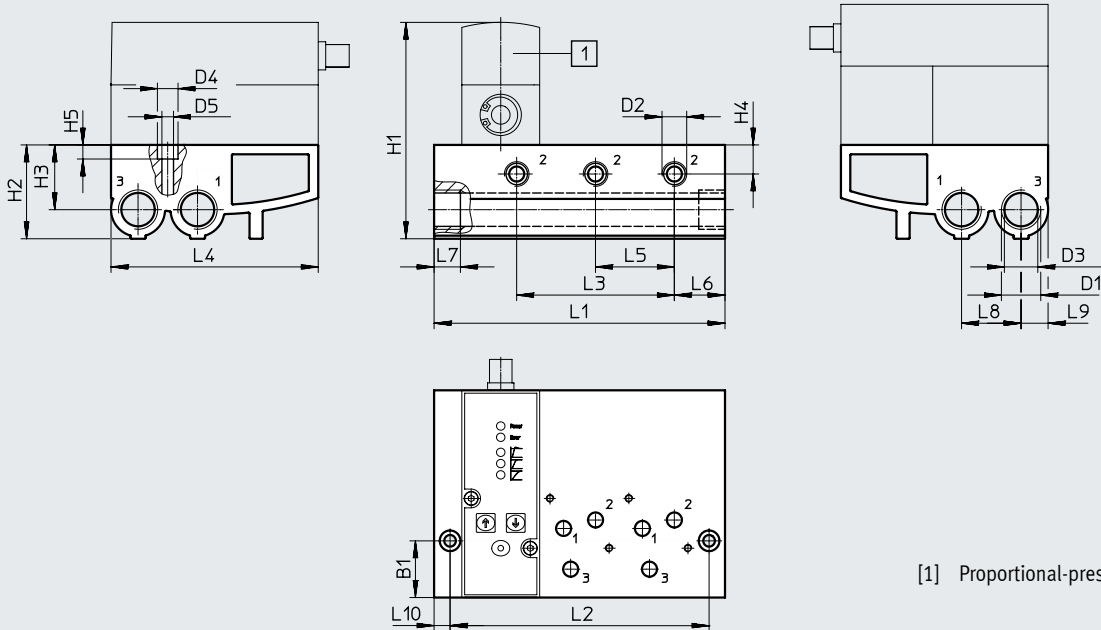

[1] Proportional-pressure regulator VPPM

Type	B1	D1	D2	D3 ∅	D4 ∅	D5 ∅	H1	H2	H3	H4	H5
VABM-P1-SF-G14-2-P3	30.2	G1/2	G1/4	17.8	11	6.2	~116	50	34.5	15.5	7.5
VABM-P1-SF-G14-3-P3											
VABM-P1-SF-G14-4-P3											

Type	L1	L2	L3	L4	L5	L6	L7	L8	L9	L10
VABM-P1-SF-G14-2-P3	113	96	42	110.4	42	27	14	31.7	14.4	8.5
VABM-P1-SF-G14-3-P3	155	138	84							
VABM-P1-SF-G14-4-P3	197	180	126							

Dimensions and ordering data

Valve positions	L1	L2	L3	Weight [g]	CRC ¹⁾	Part no.	Type
2	113	96	42	900	2	542252	VABM-P1-SF-G14-2-P3
3	155	138	84	1230	2	542253	VABM-P1-SF-G14-3-P3
4	197	180	126	1565	2	542254	VABM-P1-SF-G14-4-P3

1) Corrosion resistance class CRC 2 to Festo standard FN 940070

Moderate corrosion stress. Indoor applications in which condensation can occur. External visible parts with primarily decorative surface requirements which are in direct contact with a normal industrial environment.

 Note

In combination with manifold block VABM-P1- ... flanged valves VPPM-6F- ... and VPPM-8F- ... are to be used.

Accessories

Cover plate
VABB-P1

Material:
Wrought aluminium alloy, NBR, steel

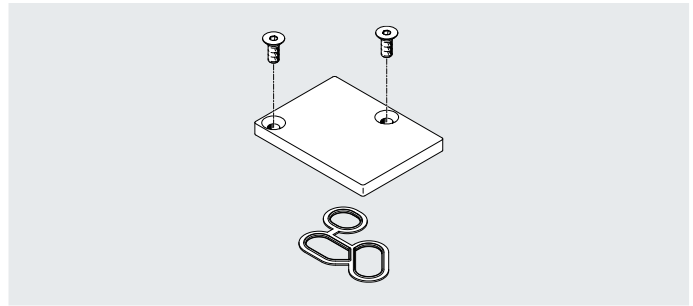

Dimensions

Download CAD data → www.festo.com

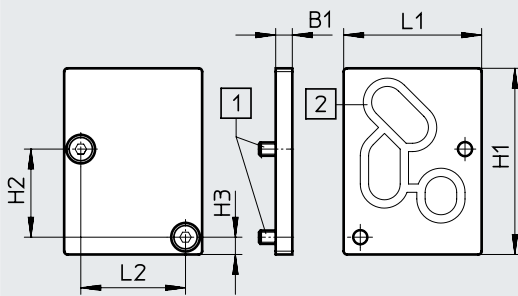

[1] Countersunk screw M4x10

[2] Seal VMPA- ...

Type	B1	H1	H2	H3	L1	L2
VABB-P1	5	56	26.5	5.2	41.5	31.5

Ordering data

Weight [g]	CRC	Part no.	Type
35	1 ¹⁾	558350	VABB-P1

1) Corrosion resistance class CRC 1 to Festo standard FN 940070

Low corrosion stress. Dry indoor application or transport and storage protection. Also applies to parts behind covers, in the non-visible interior area, and parts which are covered in the application (e.g. drive trunnions).

Accessories

Bracket
VAME-P1-A

Material:
Wrought aluminium alloy, steel

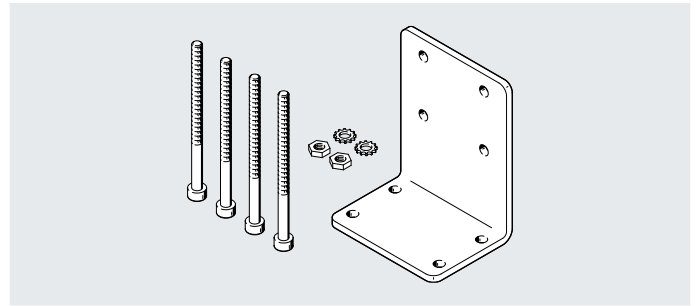

Dimensions

Download CAD data → www.festo.com

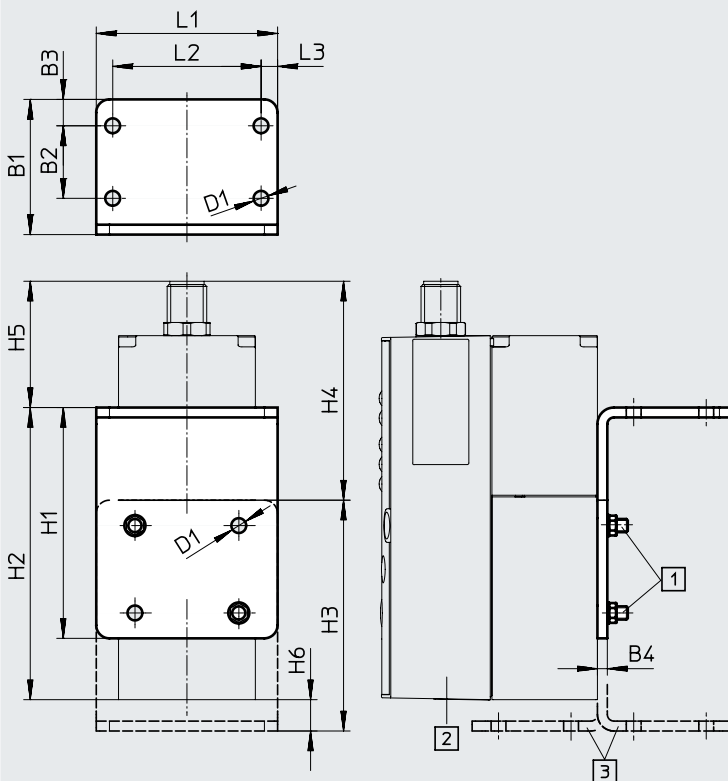

[1] Socket head screw M4

[2] Proportional-pressure regulator
VPPM

[3] Bracket can be rotated if
required

Type	B1	B2	B3	B4	D1 ∅	H1	H2	H3	H4	H5	H6	L1	L2	L3
VAME-P1-A	41	22	8	3	4.5	70	88.6	70	66.4	38.3	9.5	55	45	5

Ordering data

Weight [g]	CRC	Part no.	Type
71	1 ¹⁾	542251	VAME-P1-A

1) Corrosion resistance class CRC 1 to Festo standard FN 940070

Low corrosion stress. Dry indoor application or transport and storage protection. Also applies to parts behind covers, in the non-visible interior area, and parts which are covered in the application (e.g. drive trunnions).

Note

In combination with bracket VAME-P1-A in-line valves VPPM-6L- ... and VPPM-8L- ... are to be used.

Accessories

H-rail mounting
VAME-P1-T

Material:
Wrought aluminium alloy, steel

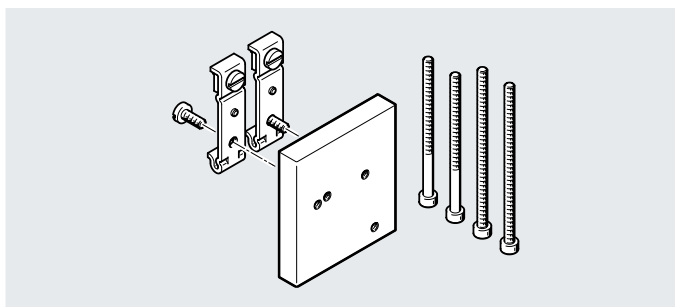

Dimensions

Download CAD data → www.festo.com

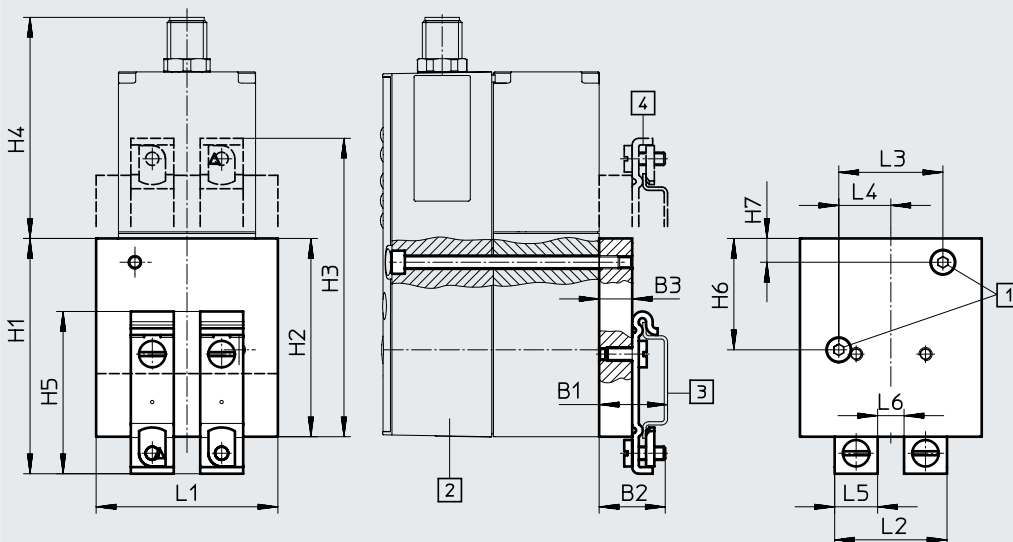

[1] Socket head screw M4

[2] Proportional-pressure regulator VPPM

[3] H-rail NRH

[4] H-rail mounting can be rotated 180° if required

Type	B1	B2	B3	H1	H2	H3	H4	H5	H6	H7	L1	L2	L3	L4	L5	L6
VAME-P1-T	20.7	20	10	71.2	60	90.3	66.9	49.1	33.7	7.2	55	34	31.5	15.75	13	8

Ordering data

Weight [g]	CRC	Part no.	Type
150	1 ¹⁾	542255	VAME-P1-T

1) Corrosion resistance class CRC 1 to Festo standard FN 940070

Low corrosion stress. Dry indoor application or transport and storage protection. Also applies to parts behind covers, in the non-visible interior area, and parts which are covered in the application (e.g. drive trunnions).

Note

In combination with H-rail VAME-P1-T in-line valves VPPM-6L- ... and VPPM-8L- ... are to be used.

Accessories

Connecting cable NEBV-M12G8-KD-3-M12G4

For connecting the proportional-pressure regulator VPPM to the analogue input and output modules of the CPX terminal.

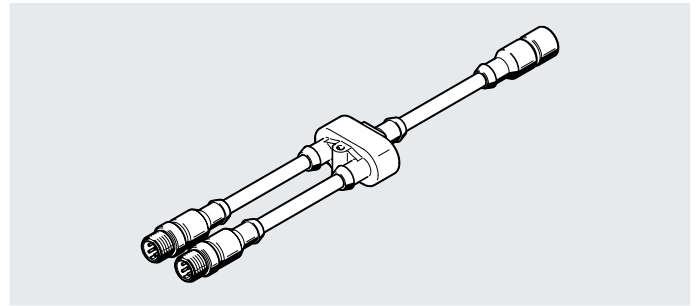

Dimensions and pin allocation

Download CAD data → www.festo.com

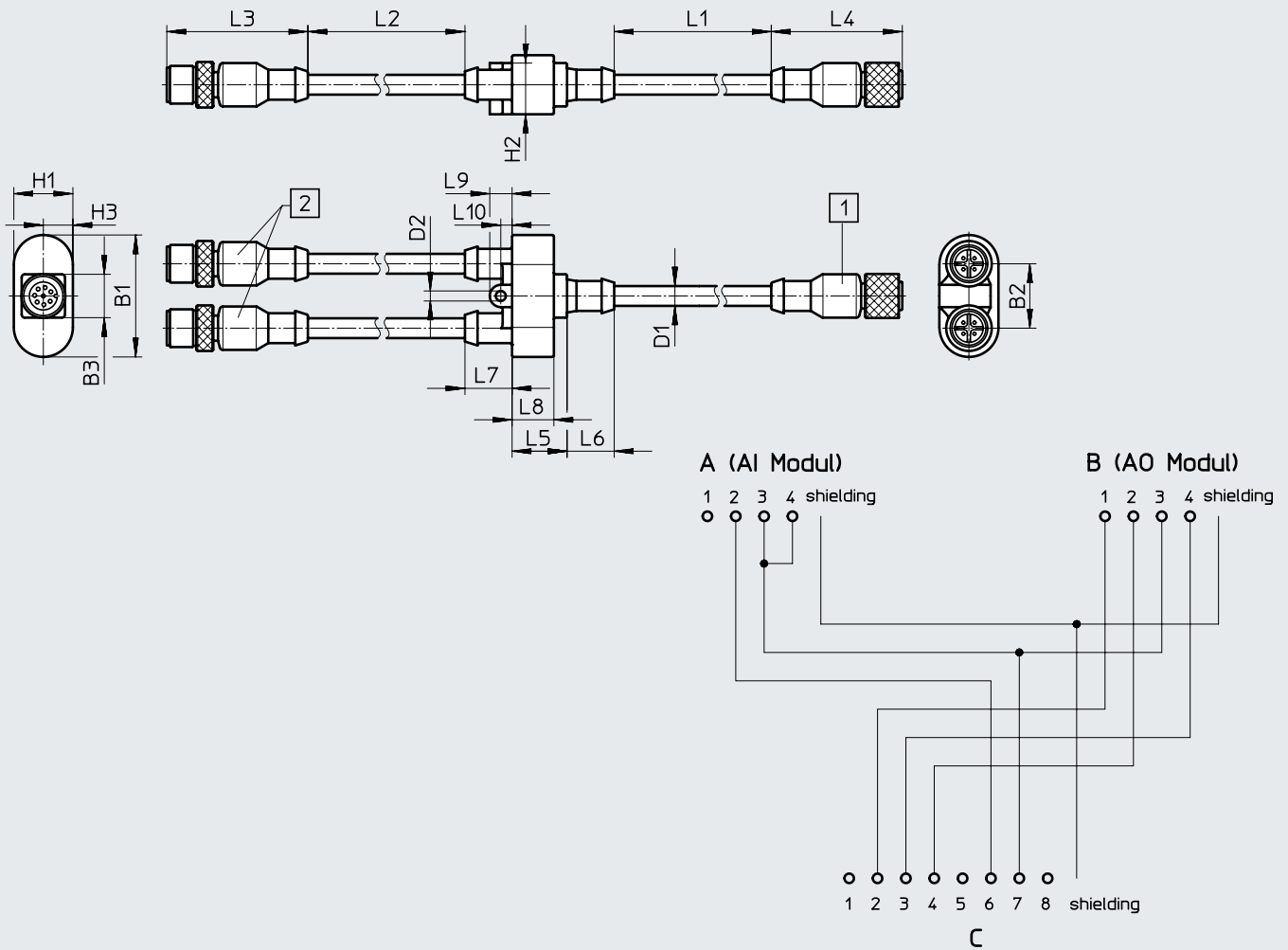

[1] Straight socket, 8-pin, to VPPM

[2] Straight plug, 4-pin, to CPX modules

Type	B1	B2	B3	D1 ∅	D2 ∅	H1	H2	H3	L1	L2	L3	L4	L5	L6	L7	L8	L9	L10
NEBV-M12G8-...	38.8	20.5	13.8	6.3	3.2	18.8	16.3	9.4	2500	500	44.9	41.7	17.5	15	15	13.3	7.1	3.6

Accessories

Connecting cable
NEBV-M12G8-K-5-M12G4

For connecting the proportional-pressure regulator VPPM to the analogue output modules of the CPX terminal.

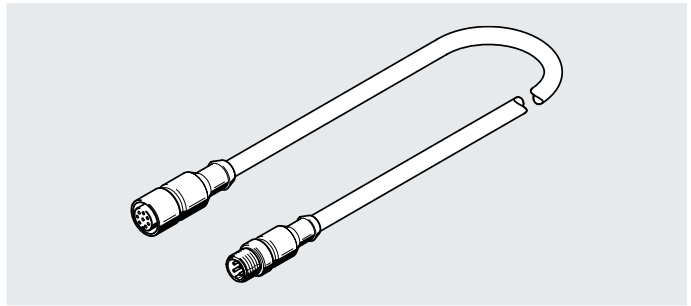

Dimensions and pin allocation

Download CAD data → www.festo.com

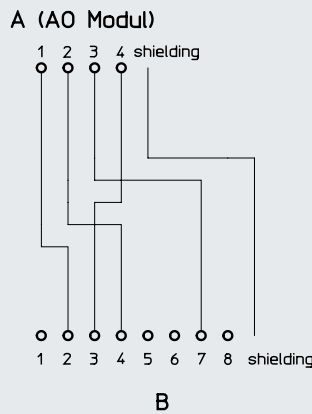
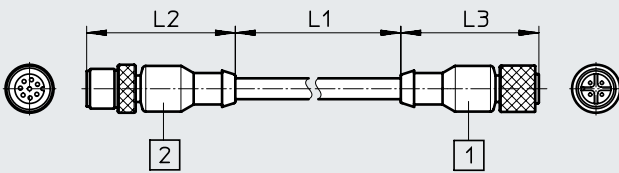

[1] Straight plug,
M12 4-pin on CPX module

[2] Straight socket,
M12 8-pin on VPPM

Type	L1	L2	L3
NEBV-M12G8-K-2-M12G4	2000	44.9	41.7
NEBV-M12G8-K-5-M12G4	5000	44.9	41.7

Ordering data		Part no.	Type
Connecting cable		Datasheets → Internet: connecting cable	
	Straight socket, 8-pin, M12	2 m	525616 SIM-M12-8GD-2-PU
		5 m	525618 SIM-M12-8GD-5-PU
		10 m	570008 SIM-M12-8GD-10-PU
	Angled socket, 8-pin, M12	2 m	542256 NEBU-M12W8-K-2-N-LE8
		5 m	542257 NEBU-M12W8-K-5-N-LE8
		10 m	570007 NEBU-M12W8-K-10-N-LE8
	One straight socket, 8-pin, and one straight plug, 4-pin	2 m	553575 NEBV-M12G8-K-2-M12G4
		5 m	553576 NEBV-M12G8-K-5-M12G4
	One straight socket, 8-pin, and two straight plugs, 4-pin	547888	NEBV-M12G8-KD-3-M12G4
Setpoint module		Datasheets → Internet: mpz	
	Setpoint module for generating 6 + 1 analogue voltage signals	546224	MPZ-1-24DC-SGH-6-SW5

Accessories

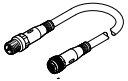
Ordering data IO-Link		Description	Part no.	Type
Connecting cable				Datasheets → Internet: connecting cable
	Straight socket, M12x1, 5-pin, degree of protection IP65, IP68, IP69K	5 m	574321	NEBU-M12G5-E-5-Q8N-M12G5
		7.5 m	574322	NEBU-M12G5-E-7.5-Q8N-M12G5
		10 m	574323	NEBU-M12G5-E-10-Q8N-M12G5