

- Precise and rigid guide
- Highly flexible
- Adjustable end-position cushioning

Mini slides SLT/SLS/SLF

Key features

General information

- Double-acting drives
- Precise and rigid guide
- Versatile air connections
- Sensors can be integrated
- Highly flexible thanks to versatile, direct assembly and connection options on:
 - Drive body
 - Slide
 - Yoke plate

Mini slides SLT



- Powerful
- Compact design through air connections at rear
- Two adjustable end-position cushioning systems:
 - Flexible cushioning elements
 - Hydraulic shock absorbers
- Extremely compact drive thanks to cushioning systems integrated in the profile section
- Versatile combination options include:
 - Drives
 - Grippers
- System product for handling and assembly technology

Mini slides SLS



- Slim design
- Integrated end-position cushioning:
 - Flexible cushioning elements

Mini slides SLF



- Flat
- Adjustable end-position cushioning
 - Flexible cushioning elements
- Versatile combination options on:
 - Drives
- System product for handling and assembly technology

Mini slides SLT/SLS/SLF

System example

System product for handling and assembly technology

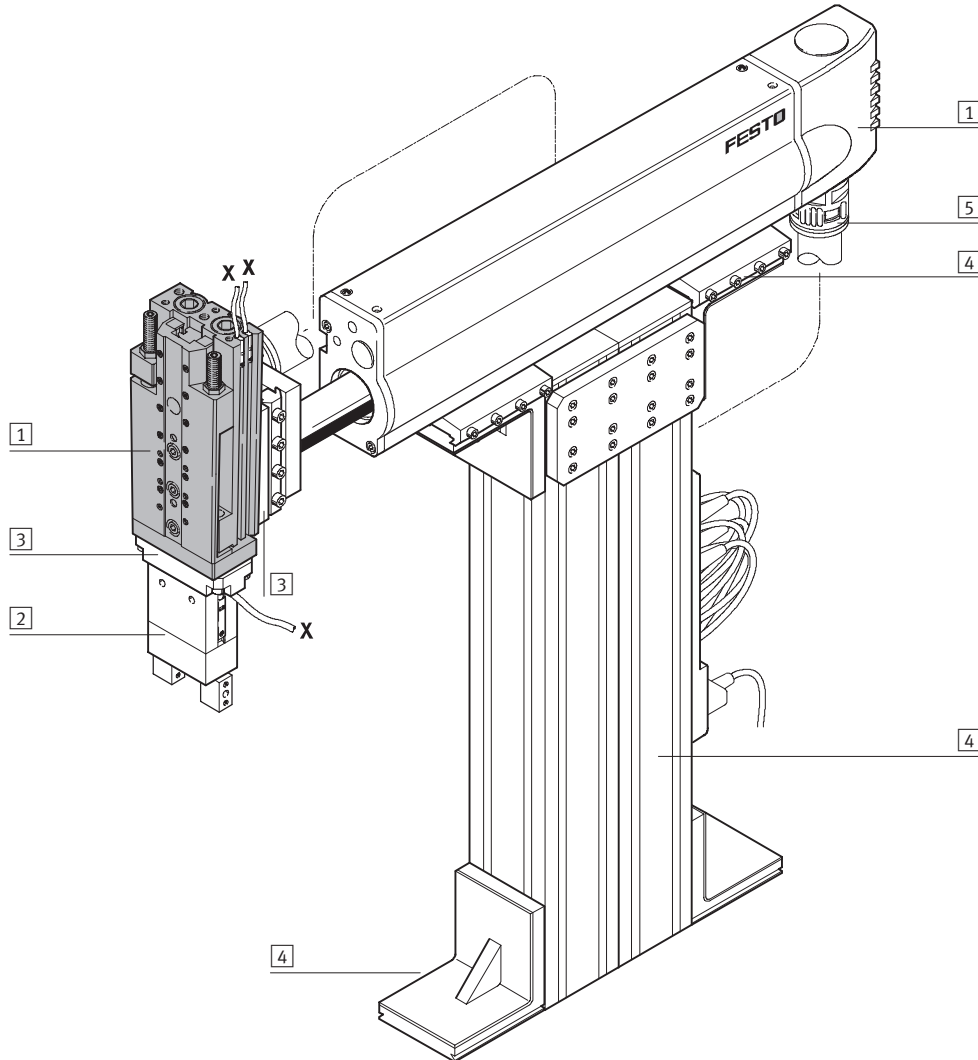

System elements and accessories		
	Brief description	→ Page
1	Drives	Diverse possible combinations in handling and assembly technology Volume 1
2	Grippers	Wide range of variation options within handling and assembly technology Volume 1
3	Adapters	For drive/drive and drive/gripper combinations Volume 5
4	Basic components	Profiles and profile connections as well as profile/drive connections Volume 5
5	Installation components	For achieving a clear-cut, safe layout of electrical cables and tubing Volume 5
-	Axes	Diverse possible combinations in handling and assembly technology Volume 5
-	Motors	Servo and stepper motors, with or without gearing Volume 5

Mini slides SLT/SLS/SLF

Key features



Drive

Mini slides SLT/SLS/SLF are driven with double-acting cylinders.

SLT: with two pistons

SLS/SLF: with one piston

Guide

The slide moves on a pre-loaded, backlash-free precision ball bearing cage guide of high rigidity with high torque and load absorption.

SLT-/SLS-/SLF-6/-10/-16

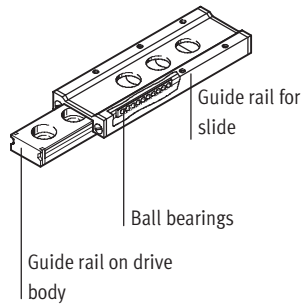

SLT-20/-25

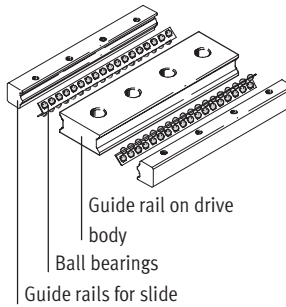

The powerful mini slide

SLT

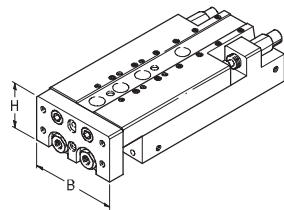

Piston Ø	Width (W)	x	Height (H)
2x 6 mm	35	x	20 mm
2x 10 mm	50	x	30 mm
2x 16 mm	66	x	40 mm
2x 20 mm	85	x	49 mm
2x 25 mm	104	x	60 mm

The super slim mini slide

SLS

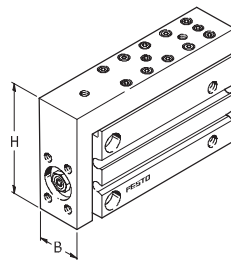

Piston Ø	Width (W)	x	Height (H)
6 mm	16	x	39 mm
10 mm	20	x	45 mm
16 mm	24	x	51 mm

The extremely flat mini slide

SLF

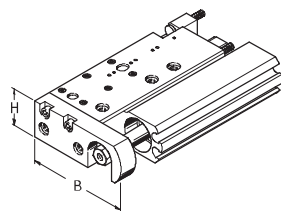

Piston Ø	Width (W)	x	Height (H)
6 mm	46	x	11 mm
10 mm	48	x	15 mm
16 mm	62	x	21 mm

Mini slides SLT/SLS/SLF

Key features

Versatile

through

- Attachment
- Mounting
- Air connection
- End-position cushioning
- Sensors

1 Attachment:
The drive can be directly attached via through or threaded holes (with appropriate screws and centring sleeves ZBH).

2 Mounting surface:
Direct attachment of devices and loads is made possible with threaded holes in the slide and the yoke plate (using appropriate screws and centring sleeves ZBS/ZBH) (e.g. SLT: semi-rotary drives and grippers).

3 Versatile air connections

4 Adjustable end-position cushioning systems:
 1) SLT-...-P-A/SLF-...-P-A with flexible cushioning elements in the end positions
 2) SLT-...-P-A with stop PF-...-SLT allows precise, metallic positioning in the end positions
 3) SLT-...-A-CC-B with hydraulic shock absorbers YSRT on rear cover for optimum end-position adjustment

5 Sensors can be integrated
Sensor slots for one or more proximity sensors SME/SMT-10. For space-saving, reliable sensing of piston positions. Proximity sensors can be freely moved and clamped in their slots.

SLT

SLT-...-CC-B

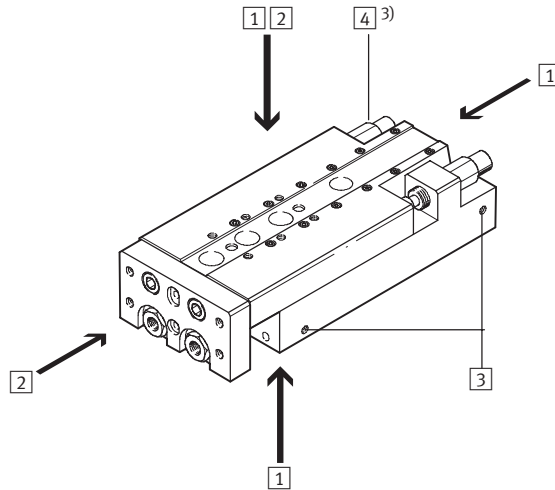

SLT-...-P-A

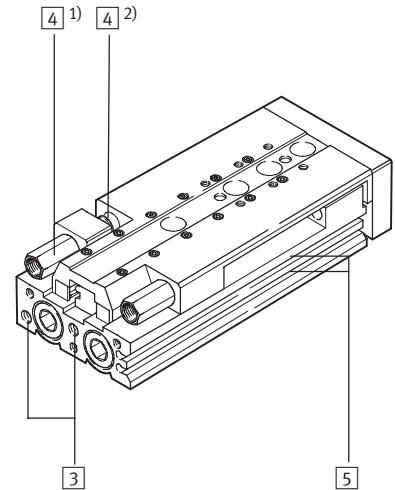

SLS

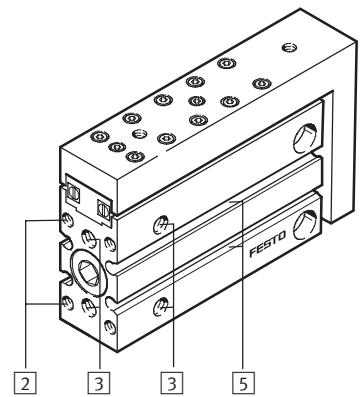
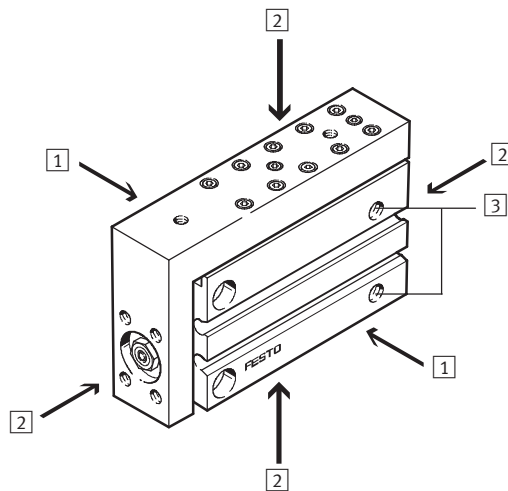

SLF

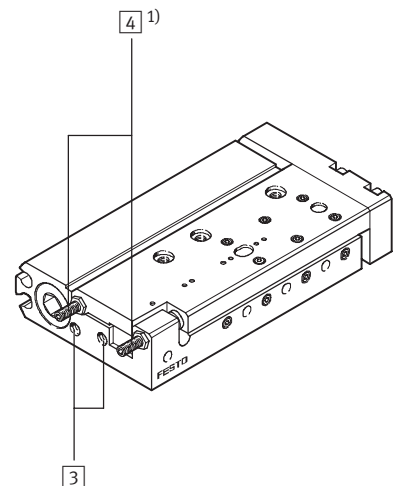
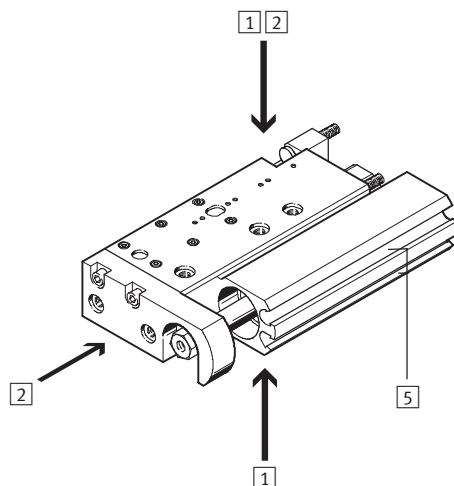

Mini slides SLT/SLS/SLF

Product range overview



Drives with linear guides
Slides

6.1

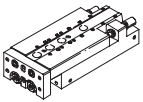
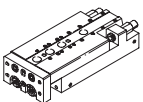
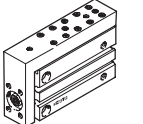
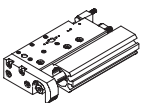
Function	Design	Piston \varnothing [mm]	Stroke [mm]	Cushioning		Position sensing	→ Page
				flexible cushioning elements	hydraulic shock absorbers		
Double-acting	Powerful, SLT-...-P-A						
		6, 10, 16, 20, 25	10, 20, 30, 40, 50, 80, 100, 125, 150, 200	■	-	■	1 / 6.1-8
	Powerful, SLT-...-A-CC-B						
		10, 16, 20, 25	30, 40, 50, 80, 100, 125, 150, 200	-	■	■	1 / 6.1-8
	Slim, SLS-...-P-A						
	6, 10, 16	5, 10, 15, 20, 25, 30	■	-	■	1 / 6.1-21	
Flat, SLF-...-P-A							
	6, 10, 16	10, 20, 30, 40, 50, 80	■	-	■	1 / 6.1-29	

Mini slides SLT

Key features





Comparison between pneumatic mini slide SLT and electric mini slide SLTE

	Pneumatic: SLT	Electric: SLTE																								
Advantages	<ul style="list-style-type: none"> • High feed force • High speed • Fast positioning time • Compact length 	<ul style="list-style-type: none"> • Gentle starting and stopping • Constant and precise speed (2 ... 200 mm/s) • Flexible positioning without mechanical devices • Programmable drive profile 																								
Guide	<ul style="list-style-type: none"> • Preloaded, backlash-free, precise and rigid ball bearing cage guide • High torque and load absorption <p>Guide rail for slide Ball bearings Guide rail on drive body</p>																									
Dimensions	<ul style="list-style-type: none"> • Identical width and height dimensions <table border="1"> <thead> <tr> <th>Type</th> <th>Width (B)</th> <th>x</th> <th>Height (H)</th> </tr> </thead> <tbody> <tr> <td>SLT(E)-10</td> <td>50</td> <td>x</td> <td>30 mm</td> </tr> <tr> <td>SLT(E)-16</td> <td>66</td> <td>x</td> <td>40 mm</td> </tr> </tbody> </table>		Type	Width (B)	x	Height (H)	SLT(E)-10	50	x	30 mm	SLT(E)-16	66	x	40 mm												
Type	Width (B)	x	Height (H)																							
SLT(E)-10	50	x	30 mm																							
SLT(E)-16	66	x	40 mm																							
Interfaces	<ul style="list-style-type: none"> • Identical mounting and attachment options <p>1 Mounting surfaces: Direct mounting using threaded holes and through-holes</p> <p>2 Attachment surfaces: Direct mounting of loads and devices (e.g. SLT: semi-rotary drives and grippers) by means of threaded holes in slide and yoke plate</p>																									
Technical data	<table border="1"> <thead> <tr> <th></th> <th>[mm]</th> <th>6 ... 25</th> <th>10, 16</th> </tr> </thead> <tbody> <tr> <td>Piston Ø</td> <td></td> <td></td> <td></td> </tr> <tr> <td>Stroke</td> <td></td> <td>10 ... 200</td> <td>50 ... 150</td> </tr> <tr> <td>Max. speed</td> <td>[m/s]</td> <td>0.8</td> <td>0.2</td> </tr> <tr> <td>Repetition accuracy at end positions</td> <td>[mm]</td> <td>±0.02</td> <td>±0.1</td> </tr> <tr> <td>Intermediate positions</td> <td></td> <td>None</td> <td>Any</td> </tr> </tbody> </table>			[mm]	6 ... 25	10, 16	Piston Ø				Stroke		10 ... 200	50 ... 150	Max. speed	[m/s]	0.8	0.2	Repetition accuracy at end positions	[mm]	±0.02	±0.1	Intermediate positions		None	Any
	[mm]	6 ... 25	10, 16																							
Piston Ø																										
Stroke		10 ... 200	50 ... 150																							
Max. speed	[m/s]	0.8	0.2																							
Repetition accuracy at end positions	[mm]	±0.02	±0.1																							
Intermediate positions		None	Any																							

Mini slides SLT

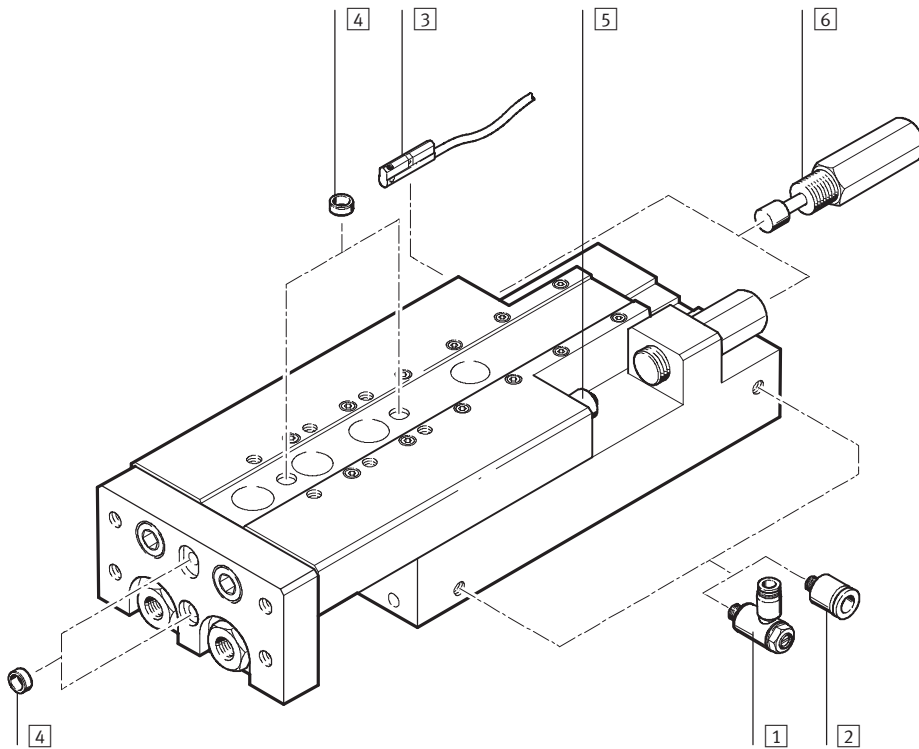

Peripherals overview



 Note
End stops must not be removed.

Accessories		
	Brief description	→ Page
1	One-way flow control valve GRLA	1 / 6.1-38
2	Push-in fitting QS	Volume 3
3	Proximity sensor SME/SMT-10	1 / 6.1-39
4	Centring pin/sleeve ZBS/ZBH	1 / 6.1-38
5	Cushioning with stop PF	1 / 6.1-38
6	Cushioning with shock absorber YSRT	1 / 6.1-38
7	Cushioning P	1 / 6.1-20

Cushioning variants

-  SLT-...-P-A
with cushioning P
-  SLT-...-P-A
with cushioning PF
(stop can be retrofitted)
-  SLT-...-CC-B
with cushioning YSRT

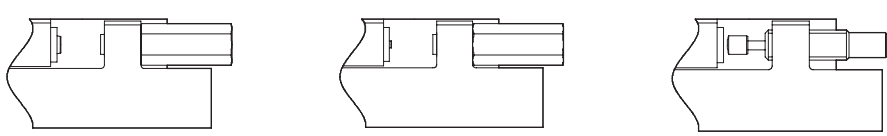

Mini slides SLT

Type codes

		SLT	-	16	-	80	-	P	-	A
Type										
Double-acting										
SLT	Mini-slide									
Piston Ø [mm]										
Stroke [mm]										
Cushioning										
P	Flexible cushioning, non-adjustable									
Position sensing										
A	For proximity sensing									

		SLT	-	16	-	80	-	A	-	CC	-	B
Type												
Double-acting												
SLT	Mini-slide											
Piston Ø [mm]												
Stroke [mm]												
Position sensing												
A	For proximity sensing											
Cushioning												
CC	Linear, self-adjusting shock absorber											
Version												
B	B series											

Mini slides SLT

Technical data



Function

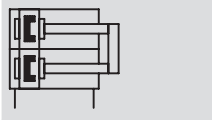

www.festo.com/en/Spare_parts_service

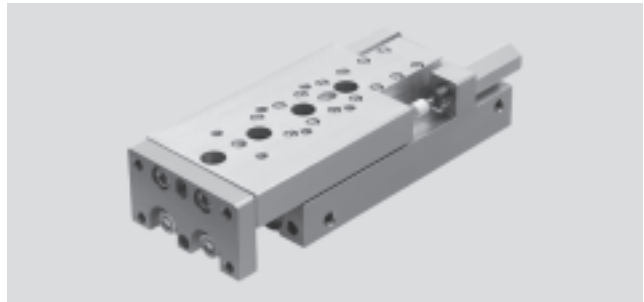

- \varnothing - Diameter
6 ... 25 mm
- | - Stroke length
10 ... 200 mm

General technical data			6	10	16	20	25
Piston \varnothing			6	10	16	20	25
Pneumatic connection			M5			G1/8	
Design	Kinematic yolk system						
Guide	Parallel piston rods, ball bearing guide						
Cushioning	Cushioning P	Non-adjustable at either end					
	Shock absorber	-			Self-adjusting at both ends		
Position sensing	For proximity sensing						
Type of mounting	Via through-holes						
	Via female thread						
Mounting position	Any						
Adjustable end-position range	Per end stop	[mm]	7	4	12		
	Per shock absorber	[mm]	-	4	5	12	
Cushioning length with shock absorbers	[mm]	-	5		8	12	
Max. advancing speed	[m/s]	0.5 ¹⁾	0.8				
Max. retracting speed	[m/s]	0.5 ¹⁾	0.8				
Repetition accuracy	Stop PF	[mm]	0.02				
	Shock absorber	[mm]	-	0.02			

1) Must be throttled externally

Operating and environmental conditions			6	10	16	20	25
Piston \varnothing			6	10	16	20	25
Operating medium	Dried compressed air, lubricated or unlubricated						
Operating pressure	[bar]	1.5 ... 10	1 ... 10				
Ambient temperature ¹⁾	[°C]	-20 ... +60					
Corrosion resistance class CRC ²⁾	1						

1) Note operating range of proximity sensors

2) Corrosion resistance class 1 according to Festo standard 940 070

Components requiring low corrosion resistance. Transport and storage protection. Parts that do not have primarily decorative surface requirements, e.g. in internal areas that are not visible or behind covers

Forces [N] and impact energy [Nm]			6	10	16	20	25
Piston \varnothing			6	10	16	20	25
Theoretical force at 6 bar, advancing			34	94	242	376	590
Theoretical force at 6 bar, retracting			25	79	218	317	495
Max. impact energy at the end positions ¹⁾	Stop PF ²⁾		0.0005	0.007	0.015	0.030	0.060
	Cushioning P ²⁾		0.016	0.1	0.3	0.4	0.5
	Shock absorber CC ²⁾		-	1	2	3	10

1) Loads moved by the slides must be taken into consideration for the calculation of end-position cushioning energy

2) Note also the graphs illustrating piston speed as a function of working load → 1 / 6.1-11

Mini slides SLT

Technical data

Weights [g]												
Piston Ø		6		10		16		20		25		
Stroke		1	2	1	2	1	2	1	2	1	2	
1	Product weight	10	177	39	365	134	635	265	1192	530	1905	880
2	Moving load	20	194	45	365	134	630	265	1182	530	1890	880
		30	210	56	398	153	665	286	1173	530	1900	880
		40	235	61	421	165	725	330	1260	580	2047	970
		50	270	76	480	195	815	390	1396	635	2197	1043
		80	-	-	631	270	1075	550	1820	780	2762	1272
		100	-	-	-	-	1280	640	2138	910	3182	1460
		125	-	-	-	-	1540	735	2535	1007	3714	1695
		150	-	-	-	-	1665	830	2933	1104	4243	1950
		200	-	-	-	-	-	-	3728	1201	5300	2393

Materials

Sectional view

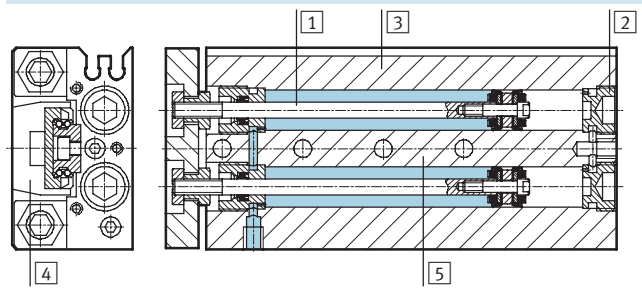

Mini slide		
1	Piston rod	High-alloy steel
2	Cap	Wrought aluminium alloy, anodised
3	Housing	Wrought aluminium alloy, anodised
4	Slide	Wrought aluminium alloy, anodised
5	Guide	Tempered steel
-	Seals	Hydrogenated nitrile rubber
Note on materials		Free of copper, PTFE and silicone

Piston speed v as a function of working load m

The piston speed as a function of working load may not be exceeded as the kinetic impact or residual energy in the end positions can result in damage to the drive. For the mini slide SLT with shock absorbers, the speed should not be less than 0.1 m/s, as otherwise the service life of the shock absorber will be reduced.

SLT-6/-10/-16-...-P-A

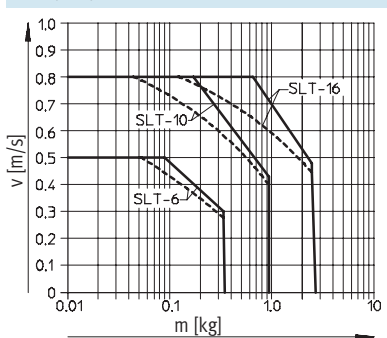

SLT-20-...-P-A

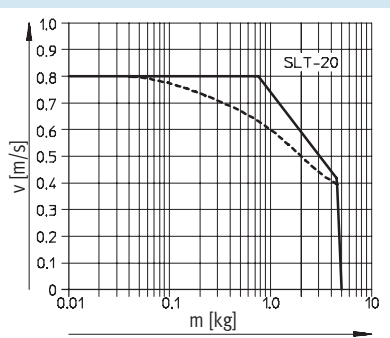

SLT-25-...-P-A

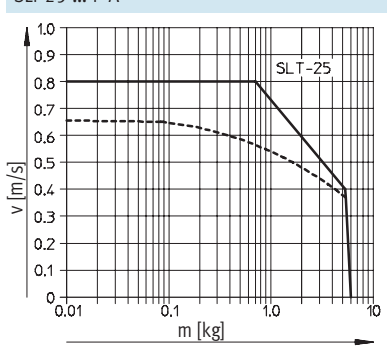

SLT-10/-16/-20/-25-...-A-CC-B

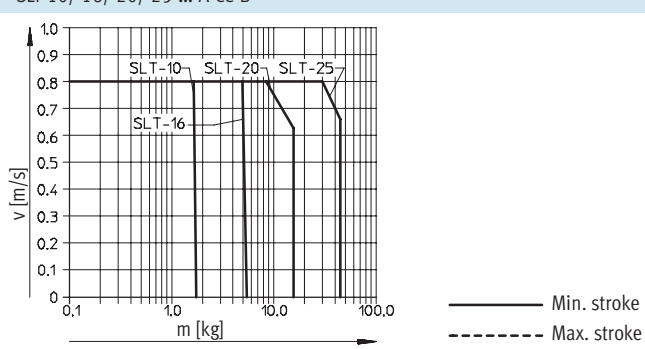

Mini slides SLT

Technical data



Dynamic characteristic load values

Torques are indicated with reference to the centre of the guide. They must not be exceeded during dynamic operation. Special attention must be paid to the cushioning phase.

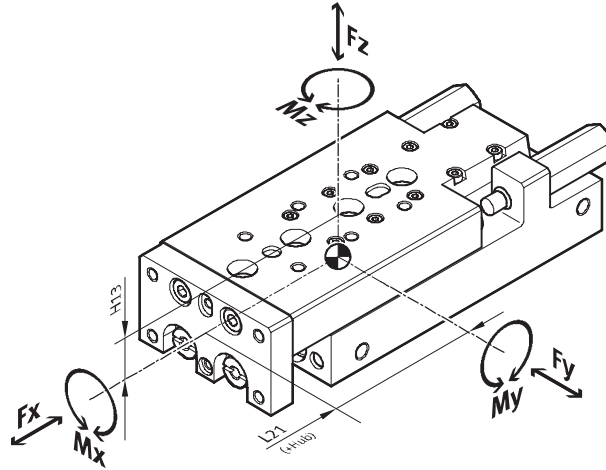

If the drive is simultaneously subjected to several of the indicated forces and torques, the following equation must be satisfied in addition to the indicated maximum loads.

$$\frac{|F_{y1}|}{F_{y\max.}} + \frac{|F_{z1}|}{F_{z\max.}} + \frac{|M_{x1}|}{M_{x\max.}} + \frac{|M_{y1}|}{M_{y\max.}} + \frac{|M_{z1}|}{M_{z\max.}} \leq 1$$

Position of guide centre

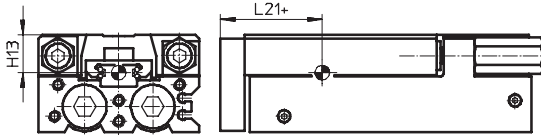

+ plus stroke length

Calculation example

Given:

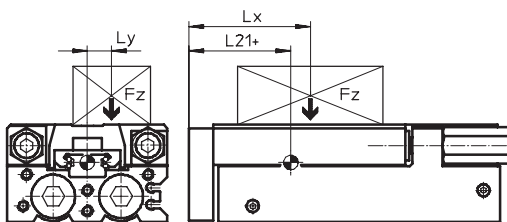

Mini slide	= SLT-10
Stroke length	= 80 mm
Lever arm L_x	= 50 mm
Lever arm L_y	= 30 mm
Mass F_z	= 0.8 kg
Acceleration a	= 0 m/s ²

To be found:

F_y, F_z, M_x, M_y, M_z
and
verification of function with combined load

Solution:

$L_{21} = 41$ mm from table

$F_y = 0$ N

$F_z = m \times g$
 $= 0.8 \text{ kg} \times 9.81 \text{ m/s}^2 = 7.848$ N

$M_x = m \times g \times L_y$
 $= 0.8 \text{ kg} \times 9.81 \text{ m/s}^2 \times 30 \text{ mm} = 0.236$ Nm

$M_y = m \times g \times [(L_{21} + \text{stroke}) - L_x]$
 $= 0.8 \text{ kg} \times 9.81 \text{ m/s}^2 [(41 \text{ mm} + 80 \text{ mm}) - 50 \text{ mm}] = 0.557$ Nm

$M_z = 0$ Nm

Combined load:

$$\frac{|F_{y1}|}{F_{y\max.}} + \frac{|F_{z1}|}{F_{z\max.}} + \frac{|M_{x1}|}{M_{x\max.}} + \frac{|M_{y1}|}{M_{y\max.}} + \frac{|M_{z1}|}{M_{z\max.}}$$

$$= 0 + \frac{7.848\text{N}}{410\text{N}} + \frac{0.2366\text{Nm}}{4.3\text{Nm}} + \frac{0.557\text{Nm}}{1.5\text{Nm}} + 0 = 0.445 \leq 1$$

Mini slides SLT

Technical data

FESTO

Permissible forces and torques						Geometric characteristics	
Piston \varnothing	Stroke	F _y max [N]	F _z max [N]	M _x max, M _y max [Nm]	M _z max [Nm]	H13 [mm]	L21 [mm]
6							
	10	200	200	1.1	0.7	7	21.5
	20	160	160	1.1	0.7		21.5
	30	140	140	0.7	0.5		21.5
	40	150	150	0.9	0.5		25
	50	190	190	1.4	0.5		30.5
10							
	10	470	470	2.1	1.6	13	24.5
	20	370	370	1.7	1.4		24.5
	30	390	390	2.5	1.4		28.5
	40	350	350	2.2	1.3		28.5
	50	390	390	3.1	1.4		33.5
	80	410	410	4.3	1.5		41
16							
	10	820	820	6.1	4.2	16	33
	20	650	650	4.7	3.4		33
	30	530	530	4.2	3.0		31.5
	40	490	490	3.8	2.7		31.5
	50	510	510	4.6	2.8		35
	80	520	520	6.0	2.8		41.5
	100	600	600	9.1	3.2		51.5
	125	960	960	12.6	3.5		66.5
	150	660	660	12.6	3.5		66.5
20							
	10	1,600	1,600	16	18	16.5	38.5
	20	1,270	1,270	13	14		38.5
	30	1,110	1,110	11	12		38.5
	40	930	930	10	11		38.5
	50	1,080	1,080	9	10		41
	80	1,030	1,030	14	11		48.5
	100	1,160	1,160	18	11		58
	125	1,380	1,380	37	17		71
	150	1,300	1,300	47	17		79
	200	1,170	1,170	64	17		92.5
	25						
	10	1,840	1,840	19	21	23.5	45.5
	20	1,460	1,460	16	16		45.5
	30	1,280	1,280	14	14		45.5
	40	1,310	1,310	13	12		45.5
	50	1,080	1,080	12	11		45.5
	80	1,030	1,030	14	11		50.5
	100	1,160	1,160	18	11		60
	125	1,380	1,380	37	17		72.5
	150	1,300	1,300	47	17		80.5
	200	1,170	1,170	64	17		94.5

Mini slides SLT

Technical data



Drives with linear guides
Slides

6.1

Dimensions

Download CAD data → www.festo.com/en/engineering

∅ 6

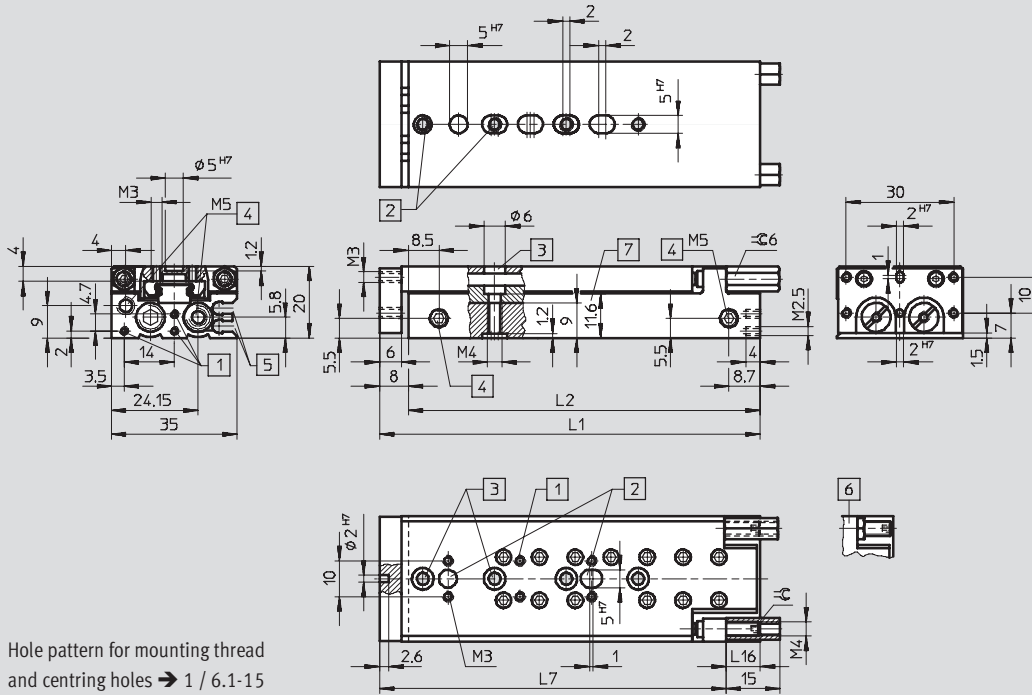

Hole pattern for mounting thread and centring holes → 1 / 6.1-15

- 1) Mounting thread
- 2) Centring holes (centring sleeves included in scope of delivery)
- 3) Through-holes for mounting the drive
- 4) Supply ports
- 5) Sensor slots for proximity sensor SME/SMT-10
- 6) Slim lock nuts are supplied loose
- 7) Through-hole length for mounting screws

∅	Stroke	L1	L2	L7	L16	≠C
[mm]	[mm]				1)	1)
6	10	48	40	38	14	2
	20	58	50	48		
	30	68	60	58		
	40	85	77	75		
	50	106	98	96		

1) With flexible cushioning

Mini slides SLT

Technical data

Hole pattern for mounting thread and centring holes

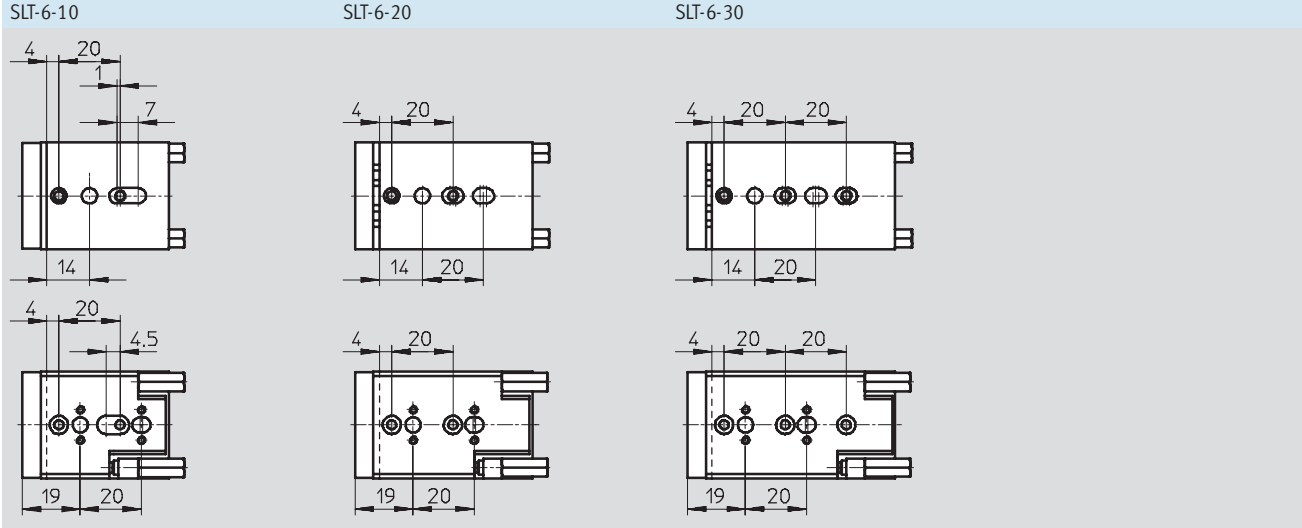

SLT-6-40	SLT-6-50
----------	----------

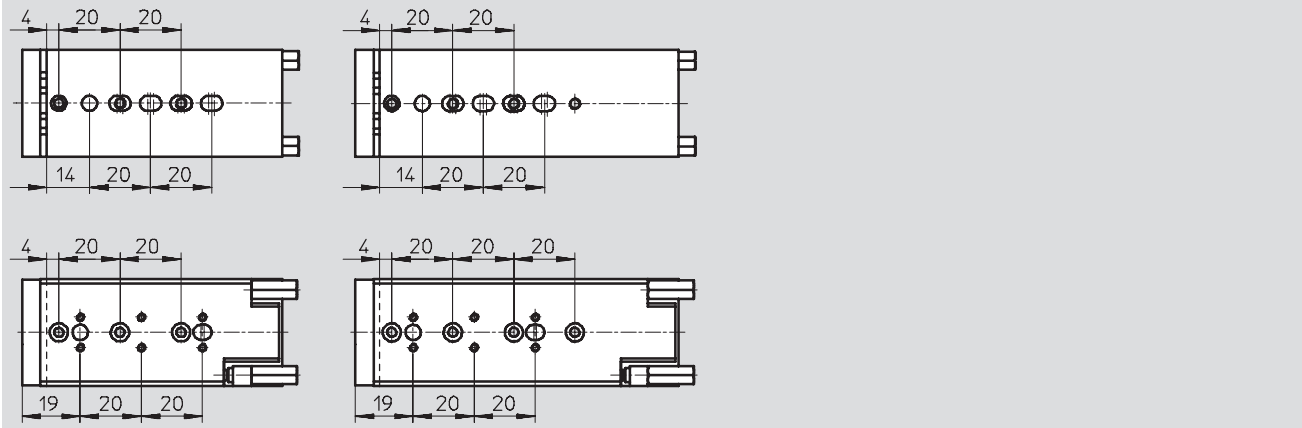

Mini slides SLT

Technical data



Dimensions

Download CAD data → www.festo.com/en/engineering

∅ 10-...-25

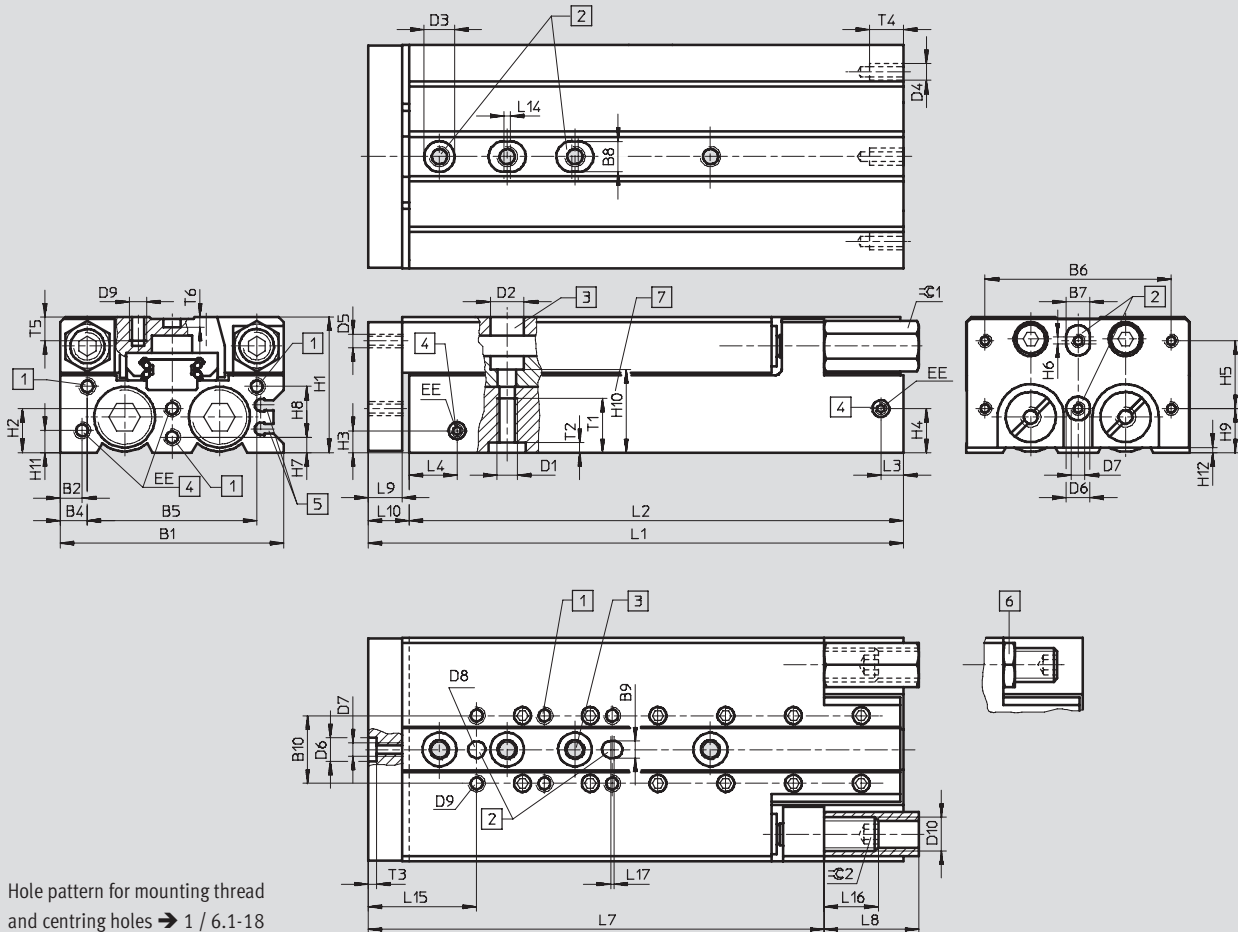

Hole pattern for mounting thread and centring holes → 1 / 6.1-18

- 1 Mounting thread
- 2 Centring holes (centring sleeves included in scope of delivery)
- 3 Through-holes for mounting the drive
- 4 Supply ports
- 5 Sensor slots for proximity sensor SME/SMT-10
- 6 Slim lock nuts are supplied loose
- 7 Through-hole length for mounting screws

∅	B1	B2	B4	B5	B6	B7	B8	B9	B10	D1	D2	D3	D4	D5	D6	D7
[mm]						H7	H7	H7			∅	∅ H7			∅ H7	
10	50	5.5	10	30	40	5	7	5	20	M5	8	7	M3	M4	5	M3
16	66	6.5	8	50	55	7	9			M6	10	9	M5	M5	7	M4
20	85	7	15	55	70	9	12	9	40	M8	11	12			9	M5
25	104	8	12	80	80	12		12					M6	M6	12	M6

∅	D8	D9	D10	EE	H1	H2	H3	H4	H5	H6	H7	H8	H9	H10	H11	H12
[mm]	∅ H7															
10	5	M4	M8x1	M5	30	9.4	5.5	11	20	2	4	10	5	15.15	5.5	1.5
16	5	M5	M10x1		40	13	6.5	13			4.5	15	13	20	6.5	1.5
20	9		M12x1	G1/8	49	19.5	9	19.7			6	19	16	30.5	9	2.5
25	12	M6	M16x1	G1/8	60	21	10	21	40		5	25	10	34.5	10	1.5

Mini slides SLT

Technical data



∅	Stroke	L1	L2	L3	L4	L7	L8	L9	L10	L14	L15		
[mm]	[mm]									min.			
10	10	72	62	7	11.7	62.5	15	8	10	2	25		
	20	72											
	30	82	72										
	40	92	82			25							
	50	112	102										
	80	162	152										
16	10	80	68	6.7	14.2	63.5	22	10	12	2	32		
	20												
	30	87	75			70.5							
	40	97	85			80.5	28						
	50	112	100			90.5							
	80	158	146			134.5							
	100	199	187	176.5									
	125	257	245	8.2	16.6	233.5							
	150	282	270			258.5							
	20	10	97	85	11.5	15.2	74					28	10
20													
30													
40		107	95	84			37						
50		122	110	92									
80		167	155	135									
100		203	191	171									
125		262	250	10.3	17.5	208	59						
150		302	290			249							
200		377	365			323							
25	10	108	94	10.7	18.7	88.5	25	12	14	2	30		
	20												
	30												
	40	118	104			92.5	34						
	50	131	117			102.5							
	80	177	163			132.5	51						
	100	210	196	159.5	57								
	125	264	250	10	21.5	212.5							
	150	304	290			252.5							
	200	379	365			328.5							

∅	L16		L17	T1	T2	T3	T4	T5	T6	≈ 1	≈ 2	
	1)	2)									1)	2)
[mm]			min.									
10	21.7	8	1	12	1.5	1.3	7	8	1.2	10	2.5	4
16	23.5	16		16	2.1	1.6	10	7		13	3	5
20	34	17.5		20	2.6	2.1		10	2.1	15	4	6
25	49.5	18				2.6	12	11	2.6	19	5	8

- 1) With hydraulic shock absorbers
- 2) With flexible cushioning

Mini slides SLT

Technical data



Drives with linear guides
Slides

6.1

Hole pattern for mounting thread and centring holes

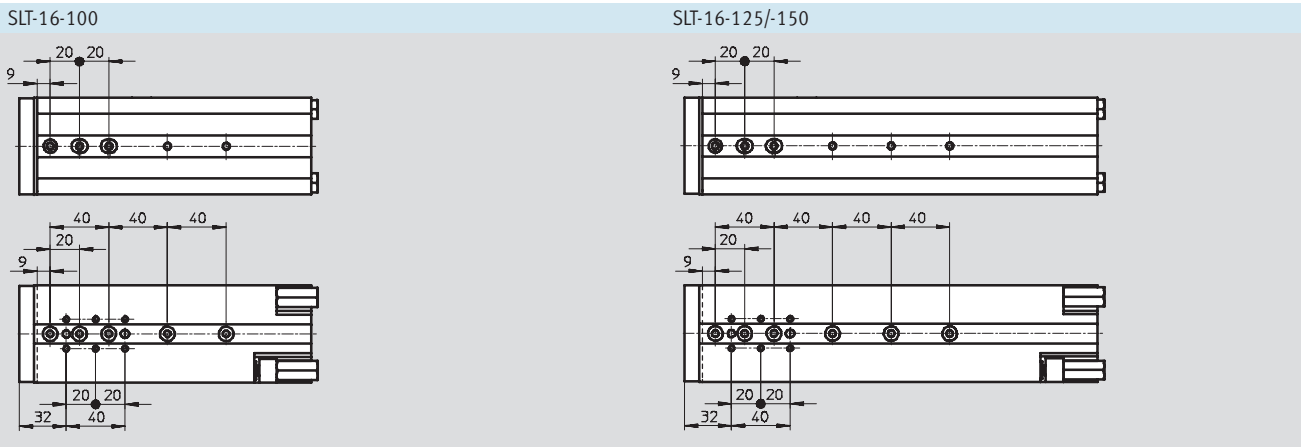
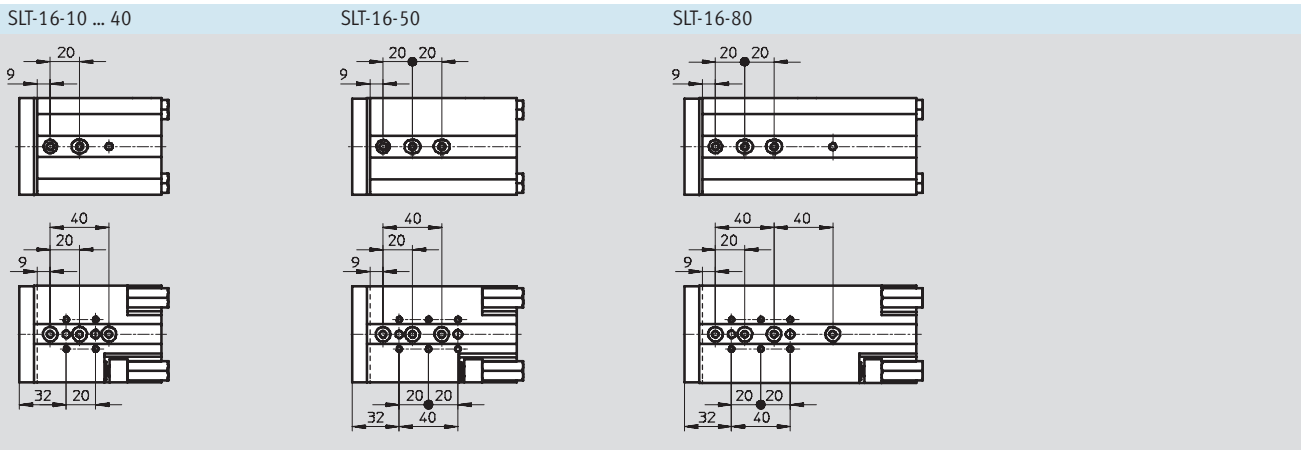
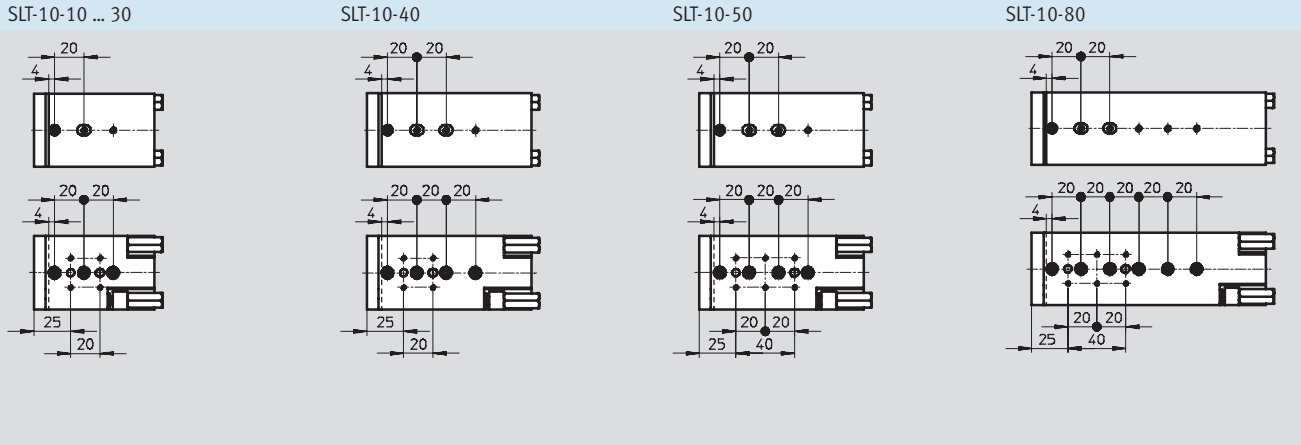

Mini slides SLT

Technical data



Hole pattern for mounting thread and centring holes

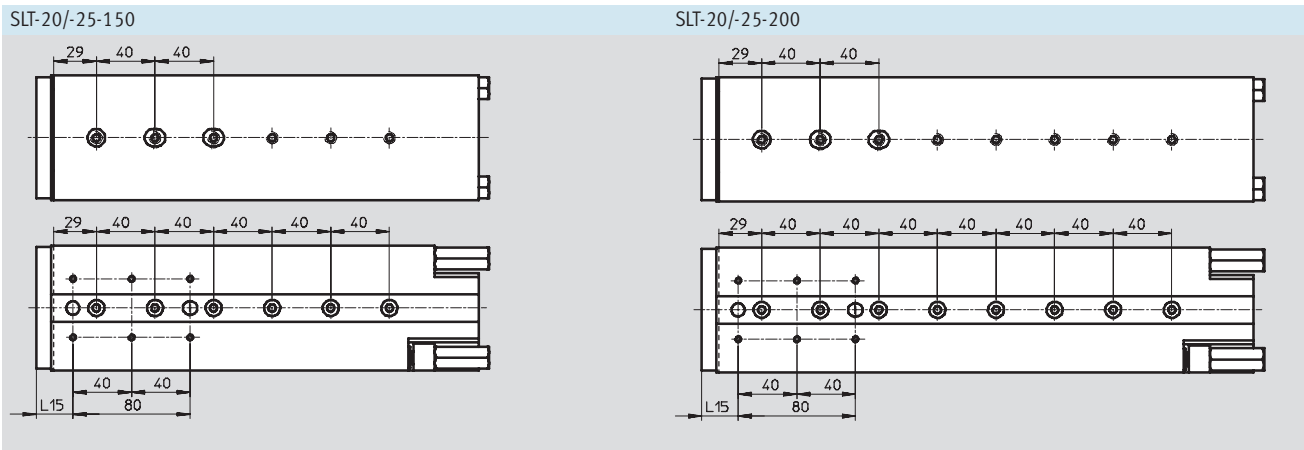
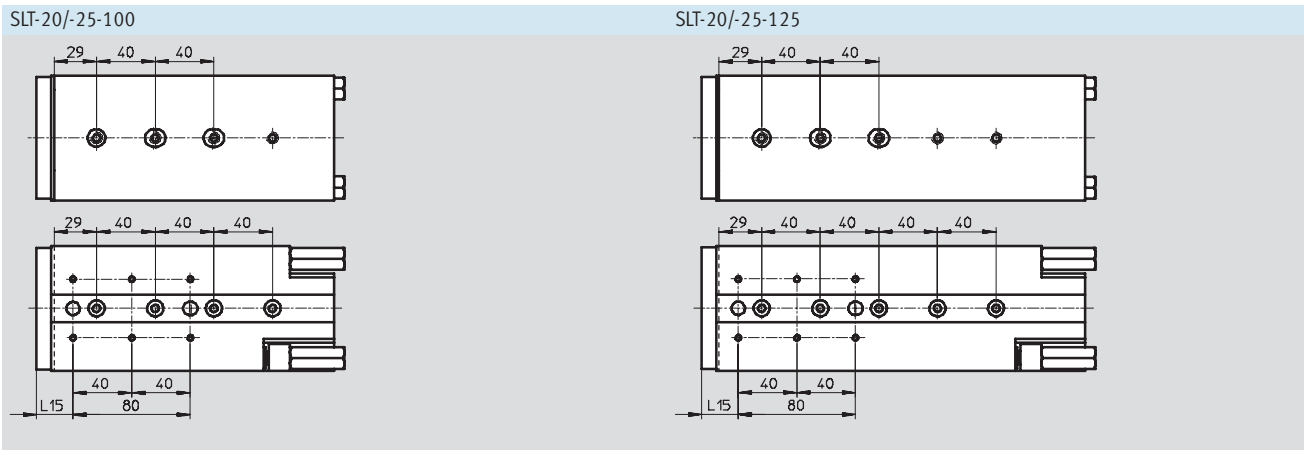
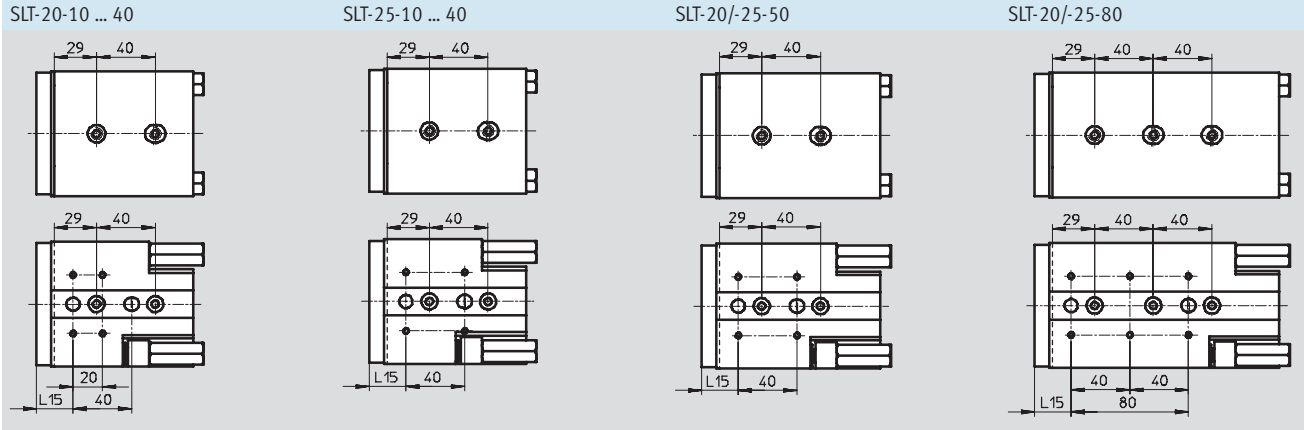

Mini slides SLT

Technical data

FESTO

Drives with linear guides
Slides

6.1

Ordering data					
∅ [mm]	Stroke [mm]	SLT-...-P-A		SLT-...-A-CC-B	
		Part No.	Type	Part No.	Type
6					
	10	170 549	SLT-6-10-P-A	-	
	20	170 550	SLT-6-20-P-A	-	
	30	170 551	SLT-6-30-P-A	-	
	40	170 552	SLT-6-40-P-A	-	
	50	170 553	SLT-6-50-P-A	-	
10					
	10	170 554	SLT-10-10-P-A	-	
	20	170 555	SLT-10-20-P-A	-	
	30	170 556	SLT-10-30-P-A	197 891	SLT-10-30-A-CC-B
	40	170 557	SLT-10-40-P-A	197 892	SLT-10-40-A-CC-B
	50	170 558	SLT-10-50-P-A	197 893	SLT-10-50-A-CC-B
	80	170 559	SLT-10-80-P-A	197 894	SLT-10-80-A-CC-B
16					
	10	170 560	SLT-16-10-P-A	-	
	20	170 561	SLT-16-20-P-A	-	
	30	170 562	SLT-16-30-P-A	197 895	SLT-16-30-A-CC-B
	40	170 563	SLT-16-40-P-A	197 896	SLT-16-40-A-CC-B
	50	170 564	SLT-16-50-P-A	197 897	SLT-16-50-A-CC-B
	80	170 565	SLT-16-80-P-A	197 898	SLT-16-80-A-CC-B
	100	170 566	SLT-16-100-P-A	197 899	SLT-16-100-A-CC-B
	125	188 412	SLT-16-125-P-A	197 900	SLT-16-125-A-CC-B
	150	188 413	SLT-16-150-P-A	197 901	SLT-16-150-A-CC-B
20					
	10	170 567	SLT-20-10-P-A	-	
	20	170 568	SLT-20-20-P-A	-	
	30	170 569	SLT-20-30-P-A	197 902	SLT-20-30-A-CC-B
	40	170 570	SLT-20-40-P-A	197 903	SLT-20-40-A-CC-B
	50	170 571	SLT-20-50-P-A	197 904	SLT-20-50-A-CC-B
	80	170 572	SLT-20-80-P-A	197 905	SLT-20-80-A-CC-B
	100	170 573	SLT-20-100-P-A	197 906	SLT-20-100-A-CC-B
	125	188 416	SLT-20-125-P-A	197 907	SLT-20-125-A-CC-B
	150	188 417	SLT-20-150-P-A	197 908	SLT-20-150-A-CC-B
	200	188 418	SLT-20-200-P-A	197 909	SLT-20-200-A-CC-B
25					
	10	170 574	SLT-25-10-P-A	-	
	20	170 575	SLT-25-20-P-A	-	
	30	170 576	SLT-25-30-P-A	197910	SLT-25-30-A-CC-B
	40	170 577	SLT-25-40-P-A	197911	SLT-25-40-A-CC-B
	50	170 578	SLT-25-50-P-A	197912	SLT-25-50-A-CC-B
	80	170 579	SLT-25-80-P-A	197913	SLT-25-80-A-CC-B
	100	170 580	SLT-25-100-P-A	197914	SLT-25-100-A-CC-B
	125	188 422	SLT-25-125-P-A	197915	SLT-25-125-A-CC-B
	150	188 423	SLT-25-150-P-A	197916	SLT-25-150-A-CC-B
	200	188 424	SLT-25-200-P-A	197917	SLT-25-200-A-CC-B

Mini slides SLS

Peripherals overview and type codes

Peripherals overview

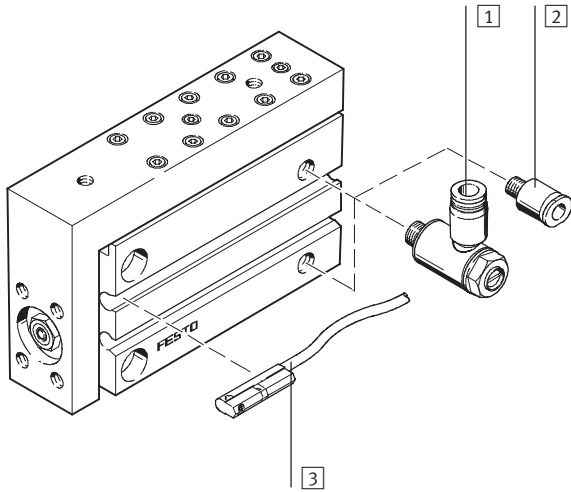

Accessories		
	Brief description	→ Page
1	One-way flow control valve GRLA	For speed regulation 1 / 6.1-38
2	Push-in fitting QS	For connecting compressed air tubing with standard external diameters Volume 3
3	Proximity sensor SME/SMT-10	Sensor slots for one or more proximity sensors 1 / 6.1-39

Type codes

		SLS	-	16	-	10	-	P	-	A
Type										
Double-acting										
SLS	Mini slide									
Piston Ø [mm]										
Stroke [mm]										
Cushioning										
P	Flexible cushioning, non-adjustable									
Position sensing										
A	For proximity sensing									

Mini slides SLS

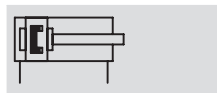

Technical data

Function



www.festo.com/en/Spare_parts_service



-  Diameter
6 ... 16 mm
-  Stroke length
5 ... 30 mm

General technical data				
Piston Ø		6	10	16
Pneumatic connection		M5		
Design		Kinematic yoke system		
Guide		Via ball bearings		
Cushioning		Non-adjustable at either end		
Position sensing		For proximity sensing		
Type of mounting		Via through-holes		
		Via female thread		
Assembly position		Any		
Max. advancing speed	[m/s]	0.5 ¹⁾	0.8	
Max. retracting speed	[m/s]	0.5 ¹⁾	0.8	

1) Must be throttled externally

Operating and environmental conditions				
Piston Ø		6	10	16
Operating medium		Dried compressed air, lubricated or unlubricated		
Operating pressure	[bar]	1.5 ... 10	1 ... 10	
Ambient temperature ¹⁾	[°C]	-20 ... +60		
Corrosion resistance class CRC ²⁾		1		

- 1) Note operating range of proximity sensors
- 2) Corrosion resistance class 1 according to Festo standard 940 070
Components requiring low corrosion resistance. Transport and storage protection. Parts that do not have primarily decorative surface requirements, e.g. in internal areas that are not visible or behind covers

Forces [N] and impact energy [Nm]				
Piston Ø		6	10	16
Theoretical force at 6 bar, advancing		17	47	121
Theoretical force at 6 bar, retracting		13	39	104
Max. impact energy at the end positions ¹⁾	Cushioning p ²⁾	0.008	0.05	0.15

- 1) Loads moved by the slides must be taken into consideration for the calculation of end-position cushioning energy
- 2) Note also the graph illustrating piston speed as a function of working load → 1 / 6.1-24

Mini slides SLS

Technical data

Weights [g]				
Piston Ø	Stroke	6	10	16
Product weight	5	69	103	195
	10	75	112	195
	15	86	126	228
	20	92	136	228
	25	103	154	259
	30	109	163	272
Moving load	5	37	49	97
	10	40	51	98
	15	48	59	111
	20	49	60	113
	25	56	69	125
	30		70	130

Materials

Sectional view

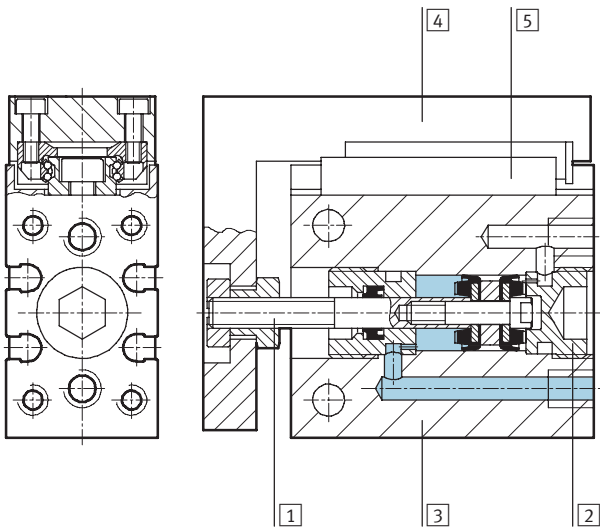

Mini slide		
1	Piston rod	High-alloy steel
2	Cap	Wrought aluminium alloy, anodised
3	Housing	Wrought aluminium alloy, anodised
4	Slide	Wrought aluminium alloy, anodised
5	Guide	Tempered steel
-	Seals	Thermoplastic rubber, hydrogenated nitrile rubber, nitrile rubber
	Note on materials	Free of copper, PTFE and silicone

Mini slides SLS

Technical data



Piston speed v as a function of working load m

SLS-6/-10/-16...-P-A

The piston speed as a function of working load illustrated in this graph may not be exceeded as the kinetic impact or residual energy in the end positions can result in damage to the drive.

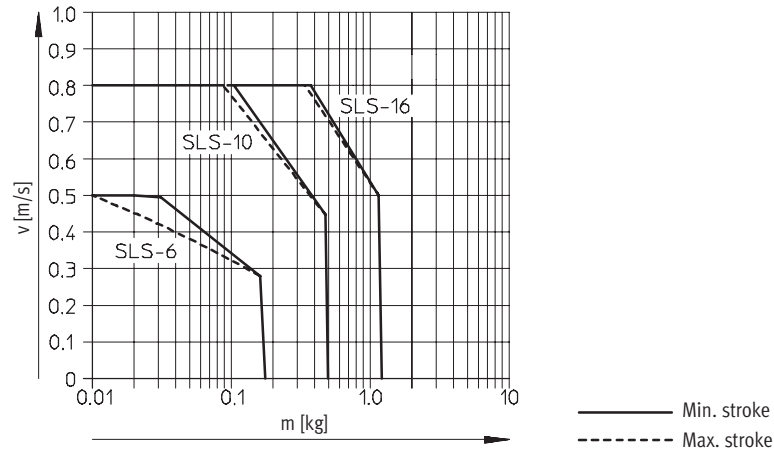

Dynamic characteristic load values

Torques are indicated with reference to the centre of the guide.

They must not be exceeded during dynamic operation. Special attention must be paid to the cushioning phase.

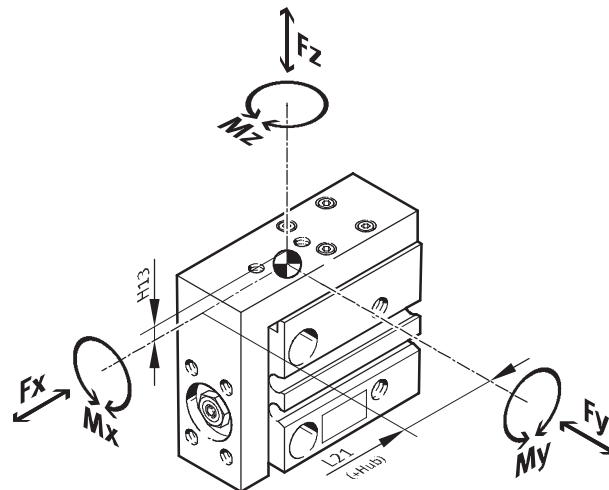

If the drive is simultaneously subjected to several of the indicated forces and torques, the following equation must be satisfied in addition to the indicated maximum loads.

$$\frac{|F_y|}{F_{y_{max}}} + \frac{|F_z|}{F_{z_{max}}} + \frac{|M_x|}{M_{x_{max}}} + \frac{|M_y|}{M_{y_{max}}} + \frac{|M_z|}{M_{z_{max}}} \leq 1$$

Position of guide centre

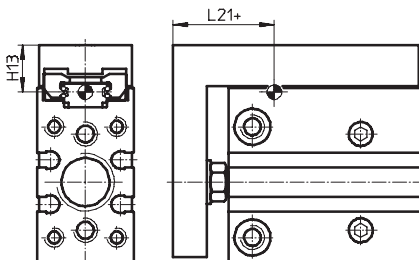

+ plus stroke length

Mini slides SLS

Technical data



Permissible forces and torques						Geometric characteristics	
Piston \varnothing	Stroke	$F_{y_{max}}$ [N]	$F_{z_{max}}$ [N]	$M_{x_{max}}, M_{y_{max}}$ [Nm]	$M_{z_{max}}$ [Nm]	H13 [mm]	L21 [mm]
6							
	5	220	220	0.6	0.5	8.5	20.5
	10	170	170	0.6	0.5		20.5
	15	180	180	0.9	0.6		23
	20	160	160	0.9	0.6		23
	25	150	150	0.9	0.6		23
	30	140	140	0.9	0.6		23
10							
	5	220	220	0.6	0.5	10	27.5
	10	170	170	0.6	0.5		27.5
	15	170	170	1.1	0.7		36
	20	150	150	1.1	0.7		36
	25	140	140	1.1	0.7		36
	30	130	130	1.1	0.7		36
16							
	5	590	590	2.1	1.6	11	30.5
	10	470	470	2.1	1.6		30.5
	15	410	410	1.7	1.3		30.5
	20	370	370	1.7	1.3		30.5
	25	410	410	2.5	1.4		34
	30	390	390	2.5	1.4		34

Calculation example

Given:

To be found:

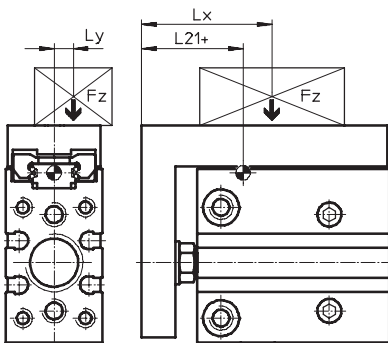

Mini slide = SLS-10
 Stroke length = 20 mm
 Lever arm L_x = 5 mm
 Lever arm L_y = 20 mm
 Mass F_z = 0.495 kg
 Acceleration a = 0 m/s²

F_y, F_z, M_x, M_y, M_z
 and
 verification of function with combined load

Solution:

$L_{21} = 36$ mm from table

$$F_y = 0 \text{ N}$$

$$F_z = m \times g = 0.495 \text{ kg} \times 9.81 \text{ m/s}^2 = 4.856 \text{ N}$$

$$M_x = m \times g \times L_y = 0.495 \text{ kg} \times 9.81 \text{ m/s}^2 \times 20 \text{ mm} = 0.097 \text{ Nm}$$

$$M_y = m \times g \times [(L_{21} + \text{stroke}) - L_x] = 0.495 \text{ kg} \times 9.81 \text{ m/s}^2 [(36 \text{ mm} + 20 \text{ mm}) - 5 \text{ mm}] = 0.248 \text{ Nm}$$

$$M_z = 0 \text{ Nm}$$

Combined load:

$$\frac{|F_y|}{F_{y_{max}}} + \frac{|F_z|}{F_{z_{max}}} + \frac{|M_x|}{M_{x_{max}}} + \frac{|M_y|}{M_{y_{max}}} + \frac{|M_z|}{M_{z_{max}}} = 0 + \frac{4.856 \text{ N}}{150 \text{ N}} + \frac{0.097 \text{ Nm}}{1.1 \text{ Nm}} + \frac{0.248 \text{ Nm}}{1.1 \text{ Nm}} + 0 = 0.345 \leq 1$$

Mini slides SLS

Technical data



Drives with linear guides
Slides

6.1

Dimensions

Download CAD data → www.festo.com/en/engineering

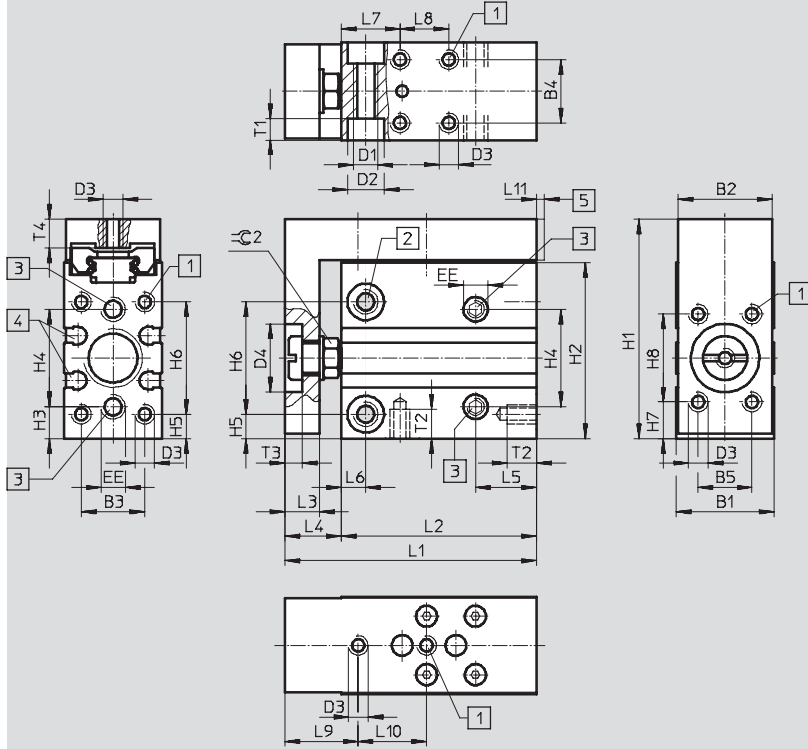

- 1 Mounting thread
- 2 Through and threaded holes for mounting the drive
- 3 Supply ports
- 4 Sensor slots for proximity sensor SME/SMT-10
- 5 Possible protrusion of the slide in relation to the edge of the housing

∅	Stroke	B1	B2	B3	B4	B5	D1	D2	D3	D4	EE	H1
[mm]	[mm]							∅		∅ H11		
6	5	16	15.3	10.5	10	9	M4	6	M3	12	M5	39
	10											
	15											
	20											
	25											
30												
10	5	20	19.3	13	13	11	M5	7.5	M4	14	M5	45
	10											
	15											
	20											
	25											
30												
16	5	24	23.3	17	17	16	M5	7.5	M4	19.5	M5	51
	10											
	15											
	20											
	25											
30												

Mini slides SLS

Technical data



∅	Stroke	H2	H3	H4	H5	H6	H7	H8	L1	L2	L3	L4	L5		
[mm]	[mm]														
6	5	31	6	17	5	19	7	15	46	37.5	6	8.5	10		
	10								51	42.5					
	15								56	47.5					
	20								61	52.5					
	25								66	57.5					
	30								71	62.5					
10	5	36	6.5	20	5	23	7.5	18	51.5	40	7	11.5	12.5		
	10								56.5	45					
	15								61.5	50					
	20								66.5	55					
	25								73.5	62					
	30								78.5	67					
16	5	41	6.5	25	5.5	27	6	26	66	52	10	14	12.5		
	10								76	62					
	15														
	20														
	25													86	72
	30													91	77

∅	Stroke	L6	L7	L8	L9	L10	L11	T1	T2	T3	T4	±C 2
[mm]	[mm]											
6	5	4	10	10	13	20	-	3.3	4.8	3	5	7
	10			15		40						
	15			20								
	20			25								
	25			30								
	30			35								
10	5	5	12	10	15	14	Max. 0.75	4.4	6	3.5	6	8
	10			14		45						
	15			18								
	20			24								
	25			32								
	30			35								
16	5	5	12	20	18	24	Max. 0.75	4.4	6	5	6	13
	10			20		55						
	15			30								
	20			40								
	25			45								
	30			45								

Mini slides SLS

Technical data

FESTO

Drives with linear guides
Slides

6.1

Ordering data			
∅ [mm]	Stroke [mm]	Part No.	Type
6			
	5	170 485	SLS-6-5-P-A
	10	170 486	SLS-6-10-P-A
	15	170 487	SLS-6-15-P-A
	20	170 488	SLS-6-20-P-A
	25	170 489	SLS-6-25-P-A
	30	170 490	SLS-6-30-P-A
10			
	5	170 491	SLS-10-5-P-A
	10	170 492	SLS-10-10-P-A
	15	170 493	SLS-10-15-P-A
	20	170 494	SLS-10-20-P-A
	25	170 495	SLS-10-25-P-A
	30	170 496	SLS-10-30-P-A
16			
	5	170 497	SLS-16-5-P-A
	10	170 498	SLS-16-10-P-A
	15	170 499	SLS-16-15-P-A
	20	170 500	SLS-16-20-P-A
	25	170 501	SLS-16-25-P-A
	30	170 502	SLS-16-30-P-A

Mini slides SLF

Peripherals overview and type codes

Peripherals overview

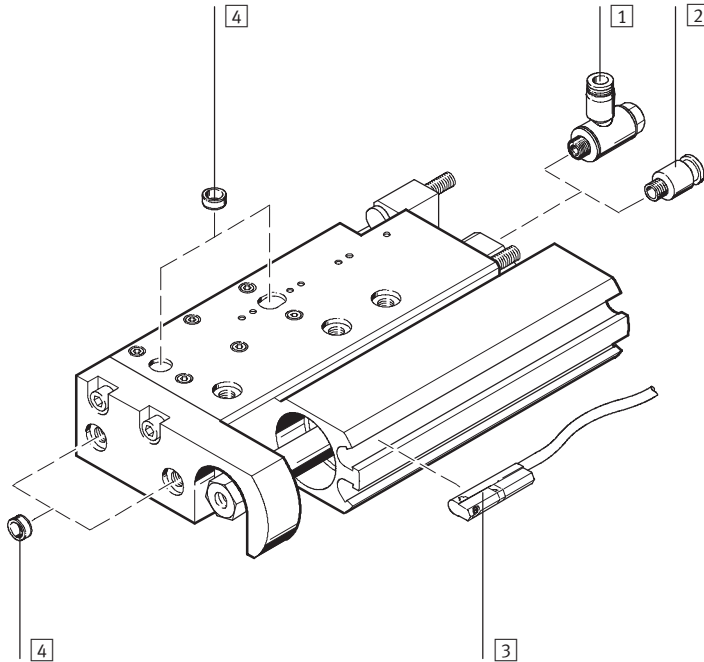

 Note
End stops must not be removed.

Accessories		Brief description	→ Page
1	One-way flow control valve GRLA	For speed regulation	1 / 6.1-38
2	Push-in fitting QS	For connecting compressed air tubing with standard external diameters	Volume 3
3	Proximity sensor SME/SMT-10	Sensor slots for one or more proximity sensors	1 / 6.1-39
4	Centring pin/sleeve ZBS/ZBH	For centring loads and attachments	1 / 6.1-38

Type codes

	SLF	-	16	-	20	-	P	-	A
Type									
Double-acting									
SLF	Mini slide								
Piston Ø [mm]									
Stroke [mm]									
Cushioning									
P	Flexible cushioning, non-adjustable								
Position sensing									
A	For proximity sensor								

Mini slides SLF

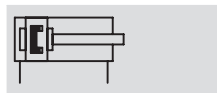

Technical data

Function

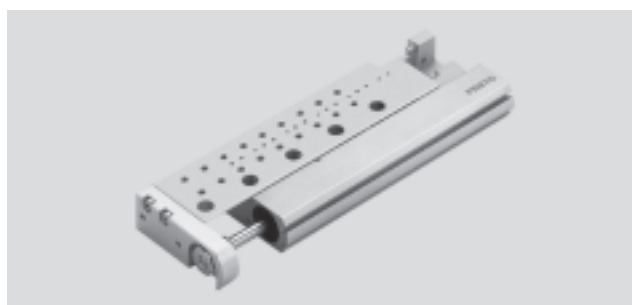

www.festo.com/en/Spare_parts_service



-  Diameter
6 ... 16 mm
-  Stroke length
10 ... 80 mm

General technical data				
Piston Ø		6	10	16
Pneumatic connection	M5			
Design	Kinematic yoke system			
Guide	Via ball bearings			
Cushioning	Non-adjustable at either end			
Position sensing	For proximity sensing			
Type of mounting	Via through-holes Via female thread			
Assembly position	Any			
Adjustable end-position range	Per end stop	[mm]	5	
Max. advancing speed	[m/s]	0.5 ¹⁾	0.8	
Max. retracting speed	[m/s]	0.5 ¹⁾	0.8	

1) Must be throttled externally

Operating and environmental conditions				
Piston Ø		6	10	16
Operating medium	Dried compressed air, lubricated or unlubricated			
Operating pressure	[bar]	1.5 ... 10	1 ... 10	
Ambient temperature ¹⁾	[°C]	-20 ... +60		
Corrosion resistance class CRC ²⁾	1			

1) Note operating range of proximity sensors

2) Corrosion resistance class 1 according to Festo standard 940 070

Components requiring low corrosion resistance. Transport and storage protection. Parts that do not have primarily decorative surface requirements, e.g. in internal areas that are not visible or behind covers

Forces [N] and impact energy [Nm]				
Piston Ø		6	10	16
Theoretical force at 6 bar, advancing		17	47	121
Theoretical force at 6 bar, retracting		13	40	104
Max. impact energy at the end positions ¹⁾	Cushioning p ²⁾	0.016	0.05	0.1

1) Loads moved by the slides must be taken into consideration for the calculation of end-position cushioning energy

2) Note also the graph illustrating piston speed as a function of working load → 1 / 6.1-32

Mini slides SLF

Technical data

Weights [g]				
Piston Ø		6	10	16
Product weight	10	68	90	214
	20	84	110	243
	30	100	130	274
	40	–	147	303
	50	–	183	361
	80	–	–	485
Moving load	10	44	38	94
	20	53	43	106
	30	62	49	119
	40	–	55	128
	50	–	66	145
	80	–	–	189

Materials

Sectional view

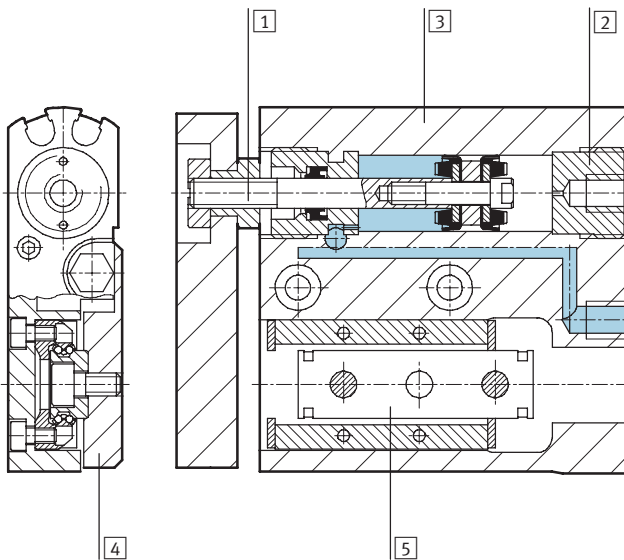

Mini slide		
1	Piston rod	High-alloy steel
2	Cap	Wrought aluminium alloy, anodised
3	Housing	Wrought aluminium alloy, anodised
4	Slide	Wrought aluminium alloy, anodised
5	Guide	Tempered steel
–	Seals	Thermoplastic rubber, hydrogenated nitrile rubber, nitrile rubber
	Note on materials	Free of copper, PTFE and silicone

Mini slides SLF

Technical data



Piston speed v as a function of working load m

SLF-6/-10/-16-...-P-A

The piston speed as a function of working load illustrated in this graph may not be exceeded as the kinetic impact or residual energy in the end positions can result in damage to the drive.

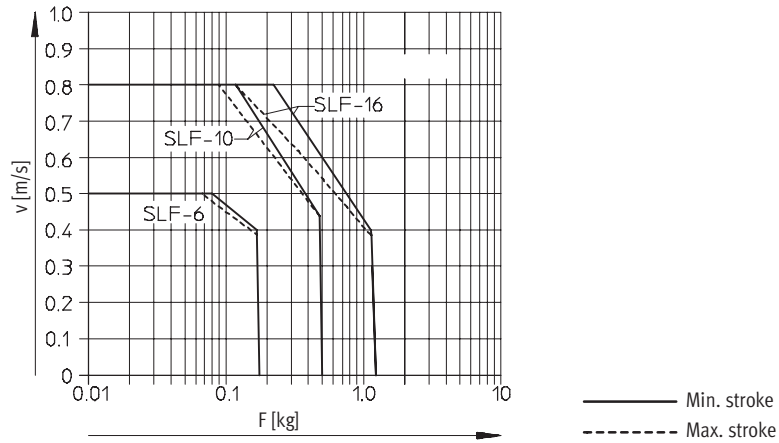

Characteristic load values

Torques are indicated with reference to the centre of the guide. They must not be exceeded during dynamic operation. Special attention must be paid to the cushioning phase.

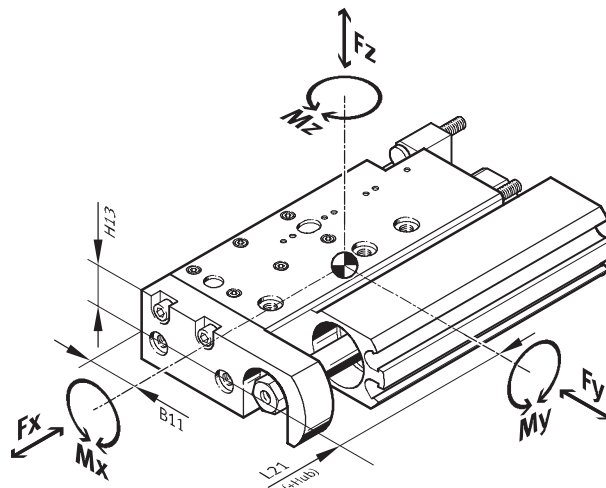

If the drive is simultaneously subjected to several of the indicated forces and torques, the following equation must be satisfied in addition to the indicated maximum loads.

$$\frac{|F_{y1}|}{F_{y_{max}}} + \frac{|F_{z1}|}{F_{z_{max}}} + \frac{|M_{x1}|}{M_{x_{max}}} + \frac{|M_{y1}|}{M_{y_{max}}} + \frac{|M_{z1}|}{M_{z_{max}}} \leq 1$$

Position of guide centre

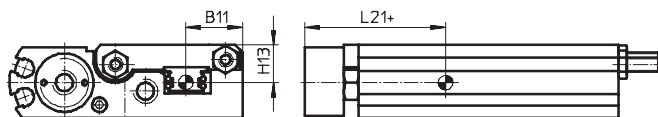

+ plus stroke length

Mini slides SLF

Technical data



Permissible forces and torques						Geometric characteristics		
Piston \varnothing	Stroke	$F_{y_{max}}$ [N]	$F_{z_{max}}$ [N]	$M_{x_{max}}, M_{y_{max}}$ [Nm]	$M_{z_{max}}$ [Nm]	B11 [mm]	H13 [mm]	L21 [mm]
6								
	10	170	170	0.6	0.5	14	7	22
	20	150	150	1.1	0.7			21
	30	130	130	1.1	0.7			21
10								
	10	170	170	0.6	0.5	11.5	8	23
	20	150	150	1.1	0.7			25
	30	130	130	1.1	0.7			25
	40	150	150	0.9	0.5			29
	50	190	190	1.4	0.5			34.5
16								
	10	470	470	2.1	1.6	14	11.5	27.5
	20	370	370	1.7	1.3			27.5
	30	390	390	2.5	1.4			31.5
	40	350	350	2.2	1.3			31.5
	50	390	390	3.1	1.4			36
	80	410	410	4.3	1.5			43.5

Calculation example

Given:

To be found:

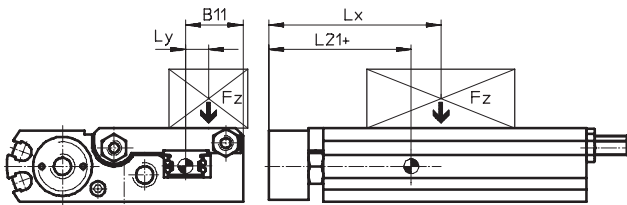

Mini slide = SLF-10
 Stroke length = 20 mm
 Lever arm L_x = 5 mm
 Lever arm L_y = 20 mm
 Mass F_z = 0.495 kg
 Acceleration a = 0 m/s²

F_y, F_z, M_x, M_y, M_z
 and
 verification of function with combined load

Solution:

$L_{21} = 25 \text{ mm}$ from table

$F_y = 0 \text{ N}$

$F_z = m \times g$
 $= 0.495 \text{ kg} \times 9.81 \text{ m/s}^2 = 4.856 \text{ N}$

$M_x = m \times g \times L_y$
 $= 0.495 \text{ kg} \times 9.81 \text{ m/s}^2 \times 20 \text{ mm} = 0.097 \text{ Nm}$

$M_y = m \times g \times [(L_{21} + \text{stroke}) - L_x]$
 $= 0.495 \text{ kg} \times 9.81 \text{ m/s}^2 [(25 \text{ mm} + 20 \text{ mm}) - 5 \text{ mm}] = 0.194 \text{ Nm}$

$M_z = 0 \text{ Nm}$

Combined load:

$$\frac{|F_y|}{F_{y_{max}}} + \frac{|F_z|}{F_{z_{max}}} + \frac{|M_x|}{M_{x_{max}}} + \frac{|M_y|}{M_{y_{max}}} + \frac{|M_z|}{M_{z_{max}}}$$

$$= 0 + \frac{4.856 \text{ N}}{150 \text{ N}} + \frac{0.097 \text{ Nm}}{1.1 \text{ Nm}} + \frac{0.194 \text{ Nm}}{1.1 \text{ Nm}} + 0 = 0.297 \leq 1$$

Mini slides SLF

Technical data



Drives with linear guides
Slides

6.1

Dimensions

Download CAD data → www.festo.com/en/engineering

∅ 6

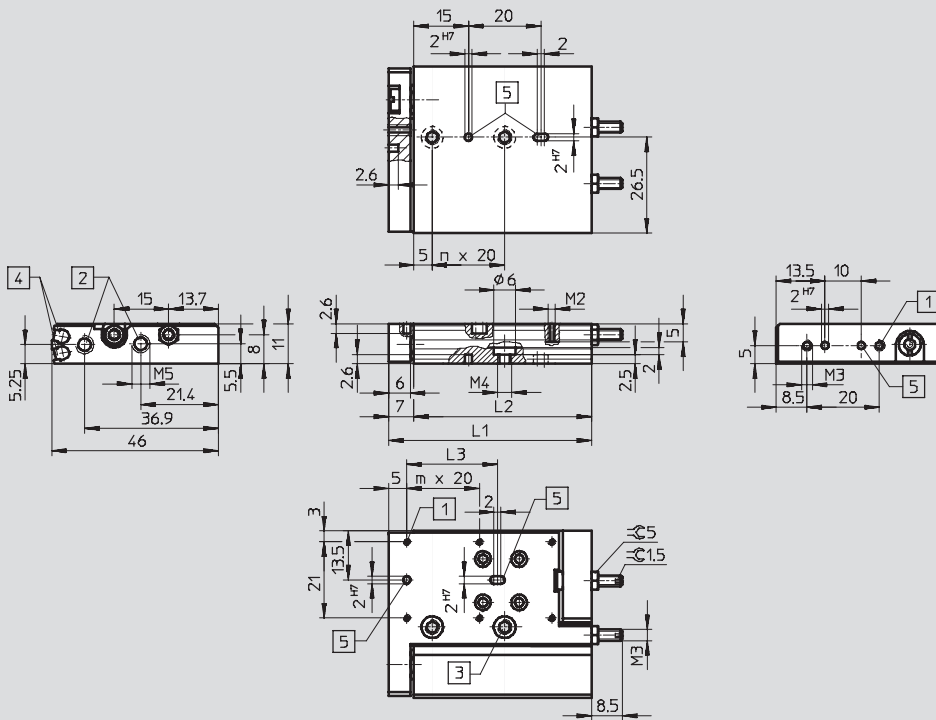

- 1 Mounting thread
- 2 Supply ports
- 3 Through-holes for mounting the drive
- 4 Sensor slots for proximity sensor SME/SMT-10
- 5 Centring holes (centring sleeves included in scope of delivery)

∅	Stroke	L1	L2	L3	m	n
[mm]	[mm]					
6	10	56	49	20	2	1
	20	66	59			2
	30	76	69	40	3	2

Mini slides SLF

Technical data

Dimensions Download CAD data → www.festo.com/en/engineering

∅ 10

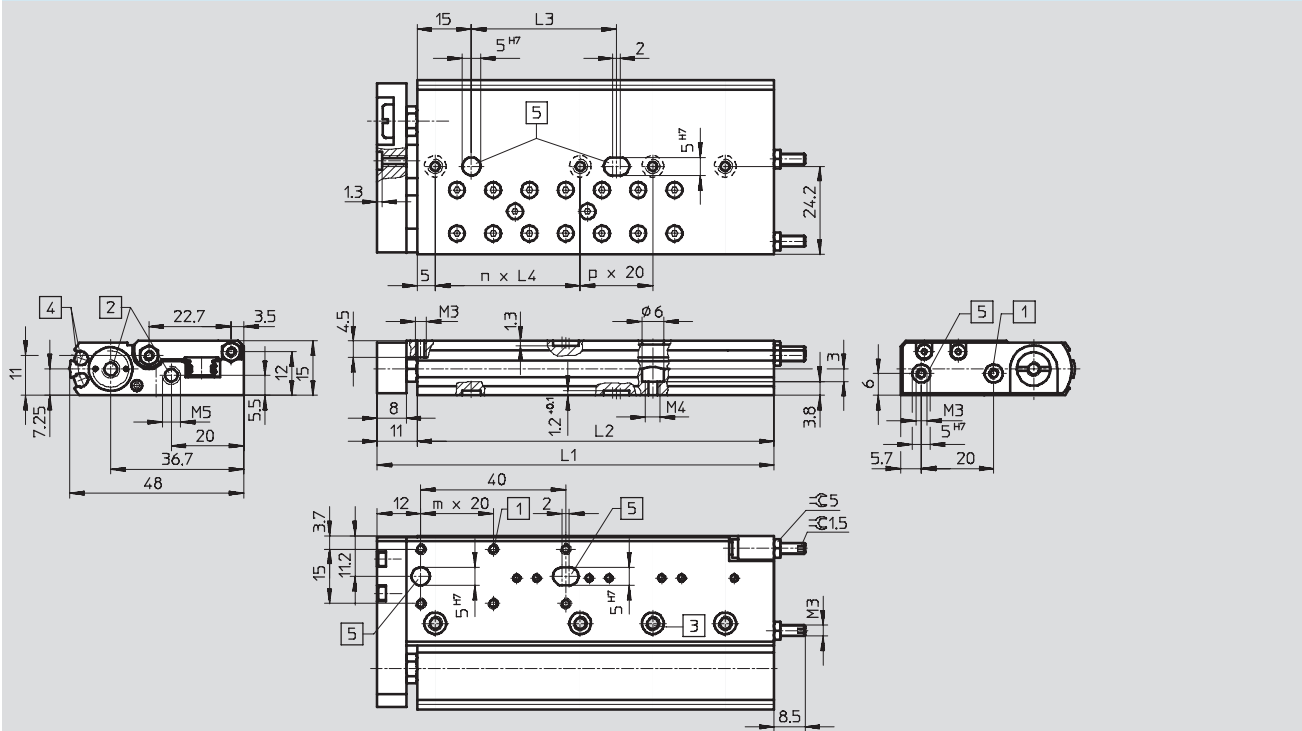

- 1 Mounting thread
- 2 Supply ports
- 3 Through-holes for mounting the drive
- 4 Sensor slots for proximity sensor SME/SMT-10
- 5 Centring holes (centring sleeves included in scope of delivery)

∅	Stroke	L1	L2	L3	L4	m	n	p
[mm]	[mm]							
10	10	59.5	48.5	20	20	1	1	-
	20	69.5	58.5				2	
	30	79.5	68.5			2	3	
	40	89.5	78.5	1				
	50	109.5	98.5	40	40	2		

Mini slides SLF

Technical data



Drives with linear guides
Slides
6.1

Dimensions Download CAD data → www.festo.com/en/engineering

∅ 16

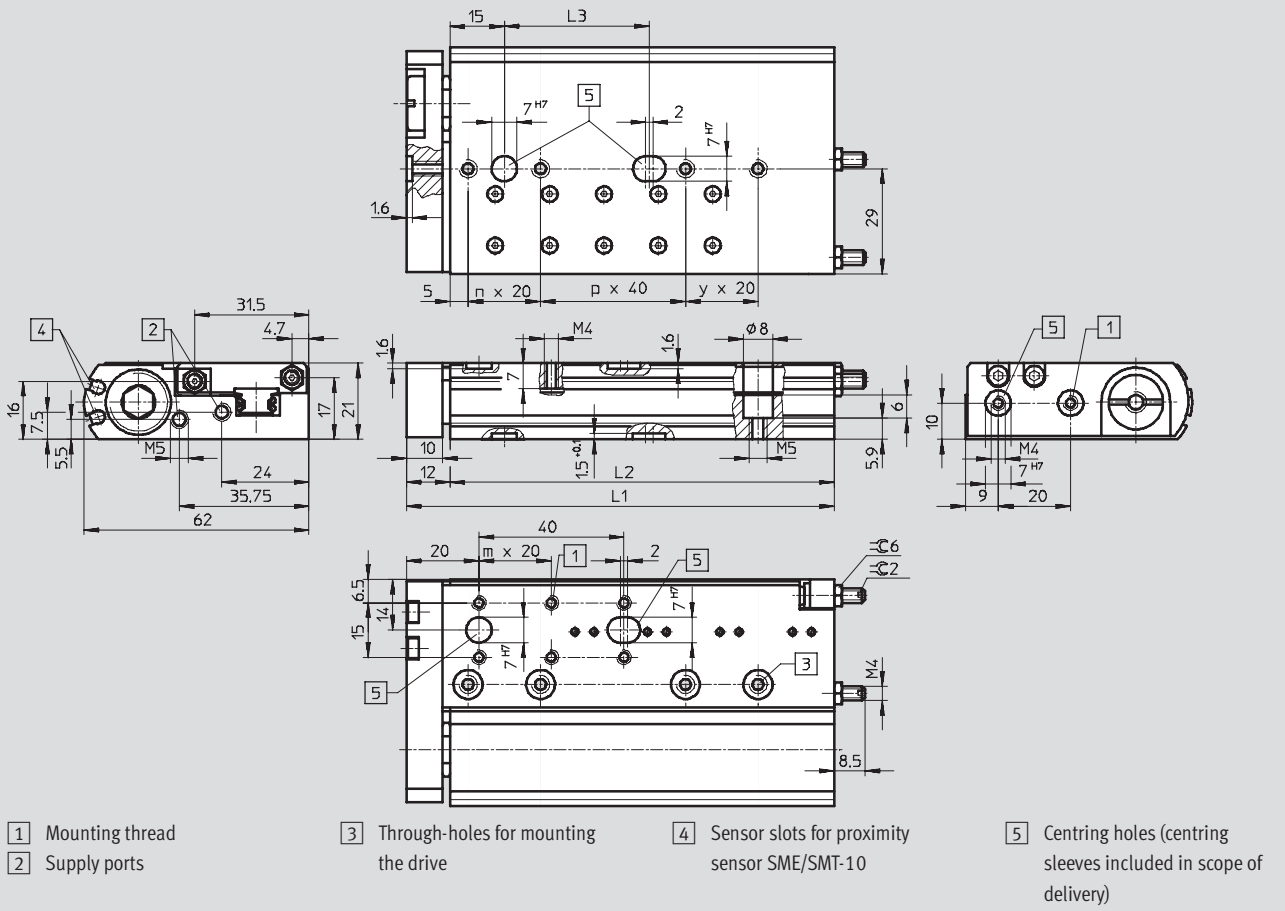

∅	Stroke	L1	L2	L3	m	n	p	y
[mm]	[mm]							
16	10	68	56	20	1	1	-	-
	20	78	66			2		
	30	88	76		3			
	40	98	86	40	2	1	1	
	50	118	106			1	2	
	80	160	148					

Mini slides SLF

Technical data

FESTO

Ordering data			
∅ [mm]	Stroke [mm]	Part No.	Type
6			
	10	170 503	SLF-6-10-P-A
	20	170 504	SLF-6-20-P-A
	30	170 505	SLF-6-30-P-A
10			
	10	170 506	SLF-10-10-P-A
	20	170 507	SLF-10-20-P-A
	30	170 508	SLF-10-30-P-A
	40	170 509	SLF-10-40-P-A
	50	170 510	SLF-10-50-P-A
16			
	10	170 511	SLF-16-10-P-A
	20	170 512	SLF-16-20-P-A
	30	170 513	SLF-16-30-P-A
	40	170 514	SLF-16-40-P-A
	50	170 515	SLF-16-50-P-A
	80	170 516	SLF-16-80-P-A

Mini slides SLT/SLS/SLF

Accessories



Ordering data											
Ordering data											
		6		10		16		20		25	
		Part No.	Type	Part No.	Type	Part No.	Type	Part No.	Type	Part No.	Type
Centring pins/sleeves for SLT ¹⁾										Technical data → 1 / 10.1-18	
	Housing	189 652	ZBH-5	186 717	ZBH-7	150 927	ZBH-9	189 653	ZBH-12	189 653	ZBH-12
	Slide	189 652	ZBH-5	189 652	ZBH-5	189 652	ZBH-5	150 927	ZBH-9	189 653	ZBH-12
	Yoke	525 273	ZBS-02	189 652	ZBH-5	186 717	ZBH-7	150 927	ZBH-9	189 653	ZBH-12
Centring pins/sleeves for SLF ¹⁾										Technical data → 1 / 10.1-18	
	Housing	525 273	ZBS-02	189 652	ZBH-5	186 717	ZBH-7	–	–	–	–
	Slide										
	Yoke										
Shock absorber for SLT-...-A-CC-B										Technical data → 1 / 9.0-2	
	–	–	–	649 653	YSRT-5-5-C	649 654	YSRT-7-5-C	649 655	YSRT-8-8-C	649 656	YSRT-12-12-C
Stop, metallic for SLT-...-P-A ²⁾											
	–	539 278	PF-06-SLT	539 279	PF-10-SLT	539 280	PF-16-SLT	539 281	PF-20-SLT	539 282	PF-25-SLT



- 1) Scope of delivery: 10 per pack
- 2) Scope of delivery: 2 per pack



Ordering data – One-way flow control valves					Technical data → Volume 2	
	Connection		Material	Part No.	Type	
	Thread	For tubing O.D.				
	M5	3	Metal design	193 137	GRLA-M5-QS-3-D	
		4		193 138	GRLA-M5-QS-4-D	
	G1/8	4		193 143	GRLA-1/8-QS-4-D	
		6		193 144	GRLA-1/8-QS-6-D	



Mini slides SLT/SLS/SLF

Accessories

FESTO

Ordering data – Proximity switches for C-slot, magneto-resistive					Technical data → www.festo.com/catalogue/sm	
	Type of mounting	Switch output	Electrical connection, connection direction	Cable length [m]	Part No.	Type
N/O contact						
	Insertable in the slot from above, flush with cylinder profile	PNP	Cable, 3-wire, in-line	2,5	525 915	SMT-10F-PS-24V-K2,5L-OE
			Plug M8x1, 3-pin, in-line	0,3	525 916	SMT-10F-PS-24V-K0,3L-M8D
			Plug M8x1, 3-pin, lateral	0,3	526 675	SMT-10F-PS-24V-K0,3Q-M8D
	Insertable in the slot lengthwise	PNP	Plug M8x1, 3-pin, in-line	0,3	173 220	SMT-10-PS-SL-LED-24
			Cable, 3-wire, in-line	2,5	173 218	SMT-10-PS-KL-LED-24

Ordering data – Proximity switches for C-slot, magnetic reed					Technical data → www.festo.com/catalogue/sm	
	Type of mounting	Switch output	Electrical connection, connection direction	Cable length [m]	Part No.	Type
N/O contact						
	Insertable in the slot from above, flush with cylinder profile	Contacting	Plug M8x1, 3-pin, in-line	0,3	525 914	SME-10F-DS-24V-K0,3L-M8D
			Cable, 3-wire, in-line	2,5	525 913	SME-10F-DS-24V-K2,5L-OE
			Cable, 2-wire, in-line	2,5	526 672	SME-10F-ZS-24V-K2,5L-OE
	Insertable in the slot lengthwise	Contacting	Plug M8x1, 3-pin, in-line	0,3	173 212	SME-10-SL-LED-24
			Cable, 3-wire, in-line	2,5	173 210	SME-10-KL-LED-24

Ordering data – Connecting cables				Technical data → www.festo.com/catalogue/nebu	
	Electrical connection, left	Electrical connection, right	Cable length [m]	Part No.	Type
	Straight socket, M8x1, 3-pin	Cable, open end, 3-wire	2,5	541 333	NEBU-M8G3-K-2.5-LE3
			5	541 334	NEBU-M8G3-K-5-LE3
	Angled socket, M8x1, 3-pin	Cable, open end, 3-wire	2,5	541 338	NEBU-M8W3-K-2.5-LE3
			5	541 341	NEBU-M8W3-K-5-LE3

