

Electric cylinder units EPCS-BS

FESTO

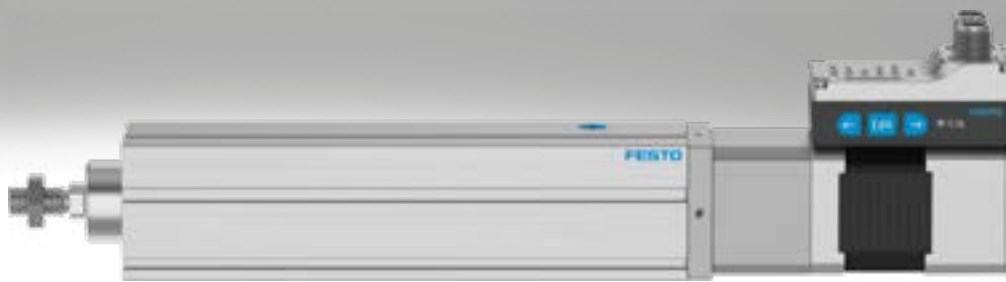

This product is also available as a modular mechanical system
Electric cylinder EPCC

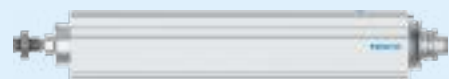

Key features

At a glance

Plug and work with the Simplified Motion Series



The simplicity of pneumatics is now combined for the first time with the advantages of electric automation thanks to the Simplified Motion Series.

These integrated drives are the perfect solution for all users who are looking for an electric alternative for very simple movement and positioning tasks between two mechanical end positions, but don't want the commissioning process for traditional electric drive systems that can often be quite complex.

Integrated

The integrated electronics in the drive are at the heart of the Simplified Motion Series.

Easy

For commissioning, simply set all relevant parameters directly on the drive:

- Speed and force
- Reference end position and cushioning
- Manual operation

Standardised

Electrical connection via M12 plug design

- Power (4-pin): power supply for the motor
- Logic (8-pin): control signal, sensor signal and power for the integrated electronics

Connected

Use of extended functions possible via IO-Link®:

- Remote configuration of motion parameters
- Copy and backup function for transferring parameters
- Read function for extended process parameters
- Freely definable intermediate position
- Firmware update



There is no need for any software since operation is simply based on the "plug and work" principle. Digital I/O (DIO) and IO-Link® are always automatically included – a product with two types of control as standard.

The functions of the Simplified Motion Series

Basic profile for movement between two end positions: with speed control

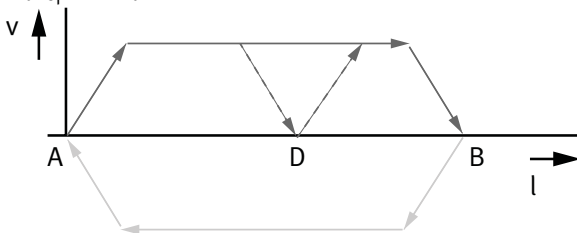

- These drives are designed for simple movements between two end positions.
- Proximity switches are required in order to implement any intermediate positions.
- With the intermediate position that can be freely configured via IO-Link®, movements can be stopped at any point between the end positions, without the need for proximity switches or external stops

Extended motion profile for simplified press-fitting and clamping functions: with speed and force control

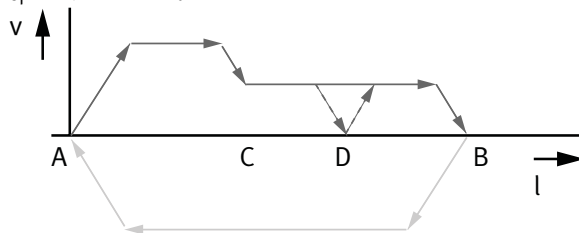

Key features

At a glance

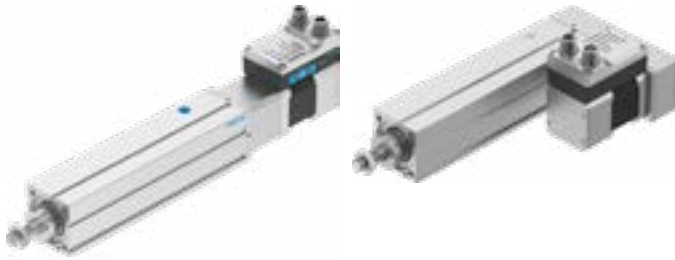

- Without external servo drive: all the necessary electronic components are combined in the integrated drive
- Two control options integrated as standard: digital I/O and IO-Link®
- Complete solution for simple movements between mechanical end positions
- Simplified commissioning: all parameters can be manually set directly on the drive
- No special expertise required for commissioning
- End-position feedback similar to that of a conventional proximity switch is integrated as standard
- Very high-quality ball screw with low internal friction
- Ideal for precise and fast movement in sorting, distribution or clamping applications

The products in the Simplified Motion Series

Electric cylinder unit
EPCE

Electric cylinder unit
EPCS

Electric cylinder unit with parallel
motor mounting
EPCS



Mini slide unit
EGSS-BS-KF



Mini slide unit with parallel motor
mounting
EGSS-BS-KF



Spindle axis unit
ELGS-BS-KF

Spindle axis unit with parallel motor
mounting
ELGS-BS-KF



Toothed belt axis unit
ELGS-TB-KF



Toothed belt axis unit
ELGE



Rotary drive unit
ERMS



Modular and flexible with motor, motor mounting kit and servo drive

This product is also available as a modular mechanical system as electric cylinder EPCC-BS:



When it comes down to flexibility and adaptability, the compact dimensions and different combinations are ideal for making optimal use of the installation space.

- Compact: optimum ratio of installation space to working space
- Unique: "one-size-down" mounting system
- Modular: individual combinations with motor, motor mounting kit and servo drive
- Flexible: wide range of mounting options for optimum machine integration

Key features

Combination matrix between axis ELGC-TB/ELGS-TB, ELGC-BS/ELGS-BS, mini slide EGSC-BS/EGSS-BS, electric cylinder EPCC-BS/EPCS-BS and guide axis ELFC
 Mounting options with profile mounting and with angle kit

	Size	Assembly axis ELGC-BS/-TB; ELFC; EGSC-BS; EPCC-BS; ELGS-BS/-TB; EGSS-BS, EPCS-BS			
		25	32	45	60
Base axis	32	■	–	–	–
ELGC-BS/-TB; ELFC;	45	–	■	–	–
ELGS-BS/-TB	60	–	–	■	–
	80	–	–	–	■

With profile mounting EAHF-L2-...-P-D...

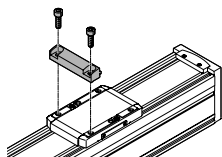

- Mounting option: base axis with one-size-down assembly axis

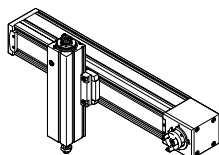
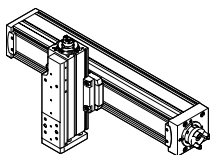

With angle kit EHAA-D-L2-...-AP

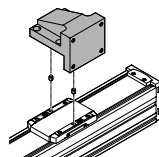

- Mounting option: base axis rotated through 90° with one-size-down assembly axis

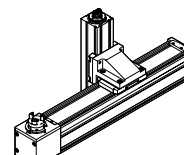
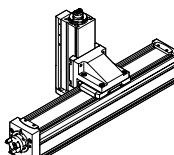

Key features

Combination matrix between axis ELGC/ELGS-TB, ELGC/ELGS-BS, mini slides EGSC/EGSS-BS, electric cylinder EPCC/EPCS-BS and guide axis ELFC

Mounting options with adapter kit or direct fastening

	Size	Assembly axis ELGC-BS/-TB; ELFC; EGSC-BS; EPCC-BS; ELGS-BS/-TB; EGSS-BS, EPCS-BS				
		25	32	45	60	80
Base axis	32		■	-	-	-
ELGC-BS/-TB; ELFC; ELGS-BS/-TB	45	-		■	-	-
	60	-	-		■	-
	80	-	-	-		■

	Size	Assembly axis EGSC-BS; EGSS-BS			
		25	32	45	60
Base axis	25	■	-	-	-
EGSC-BS; EGSS-BS	32	-	■	-	-
	45	-	-	■	-
	60	-	-	-	■

With adapter kit EHAA-D-L2

- Mounting option: base axis with the same size assembly axis
- Mounting option: base axis with height compensation for one-size-down assembly axis
- When motors are mounted using parallel kits, this may lead to interfering contours. In this case, the adapter plate is required for height compensation

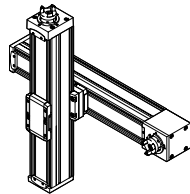
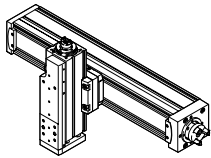
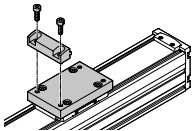

With direct mounting

- Mounting option: base axis with the same size assembly axis

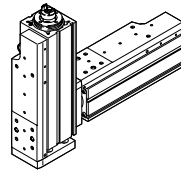

Key features

Typical handling systems

The axes ELGC can be combined into very space-saving handling systems that are suitable for assembly systems, test and inspection systems, small parts handling, the electronics industry and desktop applications where compact dimensions are essential. Combining the very compact linear axes ELGC, mini slides EGSC and electric cylinder EPCC offers an optimum ratio of installation space to working space. These feature a common system approach and platform architecture and the connections are largely adapterless.

Cantilever system

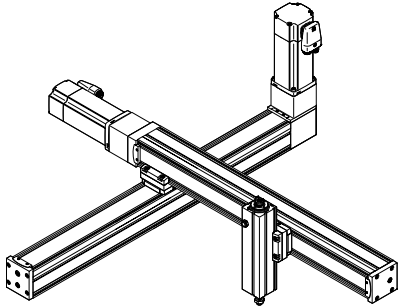

Planar surface gantry

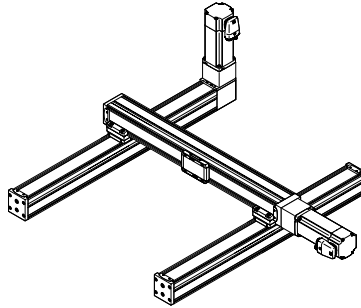

3-dimensional gantry

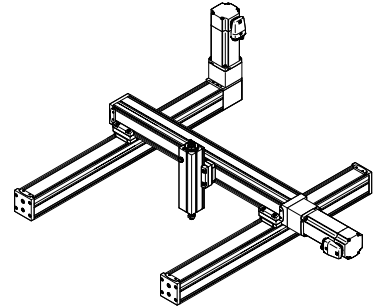

Type codes

001	Series		006	Position sensing	
EPCS	Electric cylinder		A	For proximity sensor	
002	Drive system		007	Motor type	
BS	Ball screw drive		ST	Stepper motor ST	
003	Size		008	Controller	
32	32		M	Integrated	
45	45		009	Control panel	
60	60		H1	Integrated	
004	Stroke		010	Bus protocol/activation	
25	25		PLK	PNP and IO-Link®	
50	50		NLK	NPN and IO-Link®	
75	75		011	End-position sensing	
100	100		AA	With integrated end-position sensing	
125	125		012	Cable outlet direction	
150	150			Standard	
175	175		D	Underneath	
200	200		L	Left	
250	250		R	Right	
300	300		013	Electrical accessories	
350	350			None	
400	400		L1	Adapter for operation as IO-Link® device	
500	500		014	Operating instructions	
005	Spindle pitch			With operating instructions	
3P	3 mm		DN	Without operating instructions	
5P	5 mm				
8P	8 mm				
10P	10 mm				
12P	12 mm				

Peripherals overview

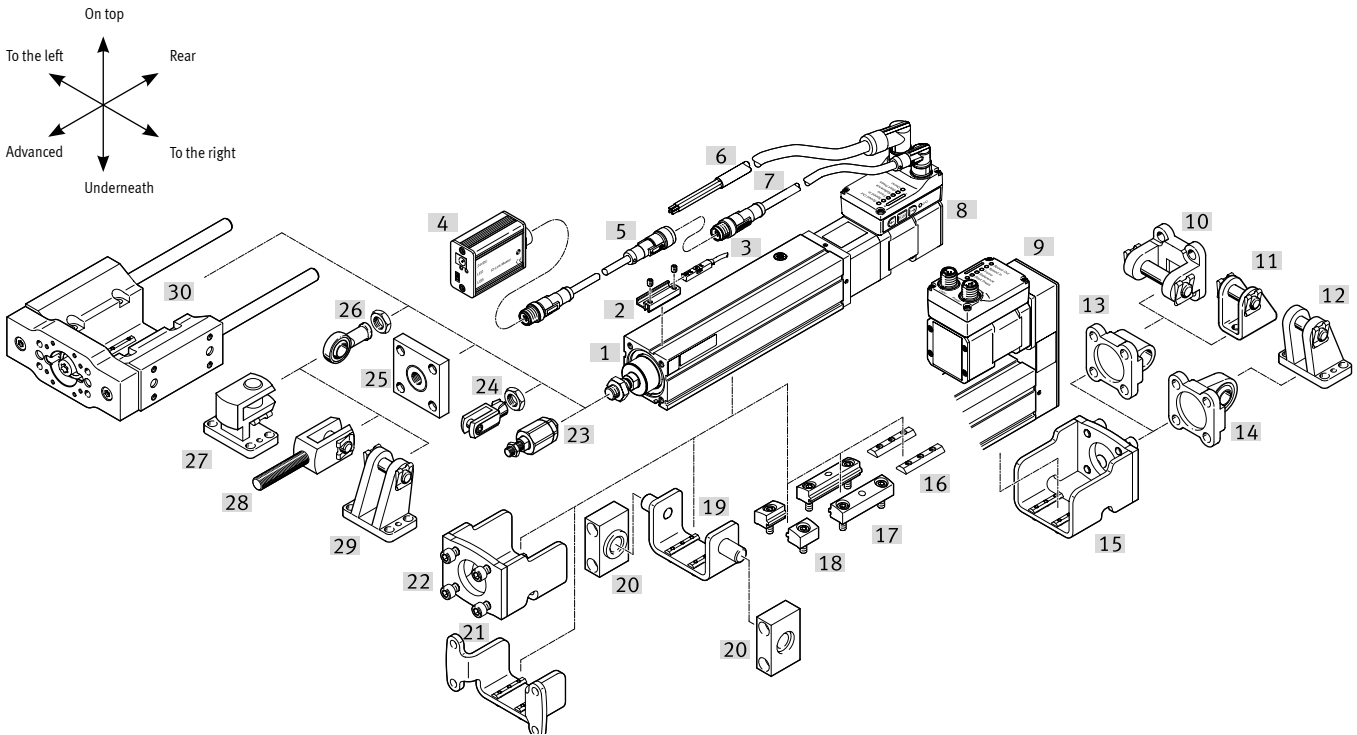

Cable outlet direction

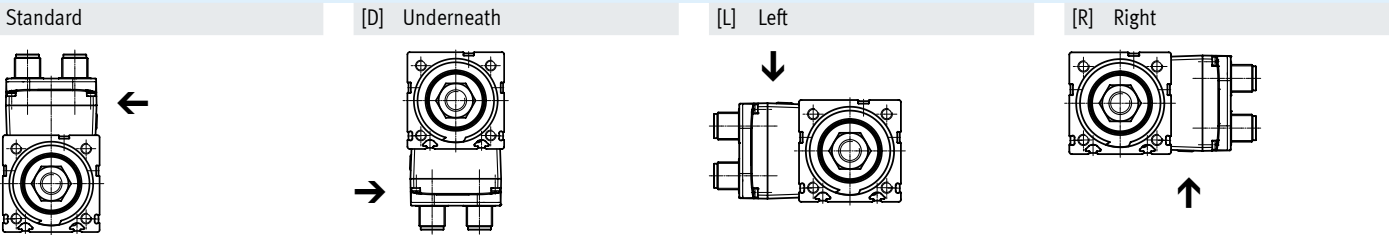

Motor attachment variants

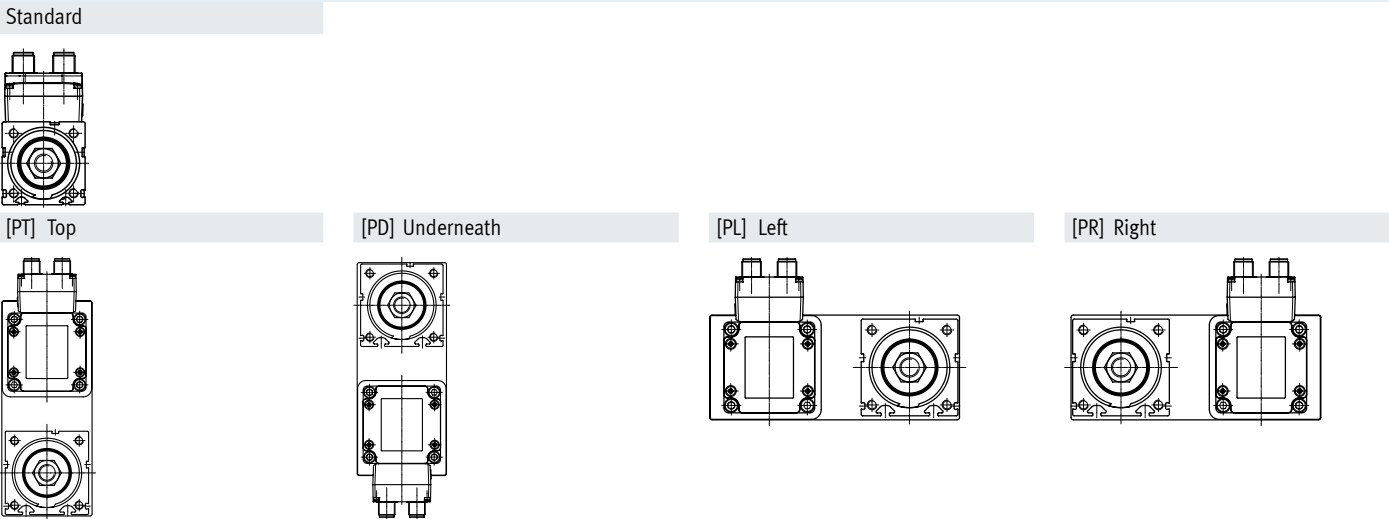

Control elements

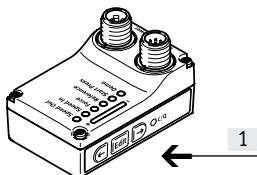

[1] Pushbutton actuators for parameterisation and control



Peripherals overview

Accessories		
Type/order code	Description	→ Page/Internet
[1] Electric cylinder unit EPCS-BS	Electric drive	8
[2] Sensor bracket ¹⁾ EAPM-L2	For mounting the proximity switches on the axis. The proximity switches can only be mounted using the sensor bracket	40
[3] Proximity switch ¹⁾ SMT-8M	Magnetic proximity switches, for T-slot	40
[4] IO-Link master USB CDSU-1	For straightforward use of the electric cylinder unit with IO-Link®	41
[5] Adapter NEFC-M12G8	<ul style="list-style-type: none"> • Connection between the motor and the IO-Link master • Only recommended for use with IO-Link® port class A master 	41
[6] Supply cable NEBL-T12	For connecting load and logic supply	41
[7] Connecting cable NEBC-M12	For connection to a controller	41
[8] Axial kit	For axial motor mounting (included in the scope of delivery)	8
[9] Parallel kit	For parallel motor mounting (included in the scope of delivery)	8
[10] Swivel flange SNCB	With parallel motor mounting, for spherical bearing	37
[11] Clevis foot LBN	With parallel motor mounting, for spherical bearing	38
[12] Clevis foot LBG/LBG-...-R3	With parallel motor mounting, for spherical bearing	38
[13] Swivel flange SNCL	With parallel motor mounting	36
[14] Swivel flange SNCS/CRSNCS/SNCS-...-R3	With parallel motor mounting	35
[15] Adapter kit EAHA-P2	<ul style="list-style-type: none"> • For mounting the swivel flange and trunnion flange on the front • Can only be mounted on the rear in conjunction with parallel kit EAMM-U 	33
[16] Slot nut ABAN	For mounting the electric cylinder	38
[17] Profile mounting EAHF-L2-P	<ul style="list-style-type: none"> • For mounting the axis on the side of the profile • The profile mounting can be attached to the mounting surface using the drilled hole in the centre 	31
[18] Profile mounting EAHF-L2-P-S	For mounting the axis on the side of the profile	30
[19] Trunnion support LNZG	For cylinders with trunnion flange mounting	34
[20] Swivel mounting EAHS-P2	Position freely selectable along the cylinder length	34
[21] Flange mounting EAHH-P2	<ul style="list-style-type: none"> • For mounting the electric cylinder via the profile • Position freely selectable along the cylinder length 	32
[22] Adapter kit EAHA-P2	<ul style="list-style-type: none"> • For mounting the swivel flange and trunnion flange on the front • Can only be mounted on the rear in conjunction with parallel kit EAMM-U 	33
[23] Self-aligning rod coupler FK/CRFK	To compensate for radial and angular deviations	38
[24] Rod clevis SG/CRSG	Permits a swivelling movement of the cylinder in one plane	38
[25] Coupling piece KSG	To compensate for radial deviations	38
[26] Rod eye SGS/CRSGS	With spherical bearing	38
[27] Right angle clevis foot LQG	For rod eye SGS	38
[28] Rod clevis SGA	For swivel mounting of the cylinder	38
[29] Clevis foot LBG/LBG-...-R3	With parallel motor mounting, for spherical bearing	38
[30] Guide unit EAGF	For protecting electric cylinders against rotation at high torque loads	39

1) Proximity switches are optional and only required in order to sense any intermediate positions.

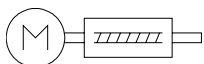
Datasheet



-  - Size
32 ... 60
-  - Stroke length
25 ... 500 mm

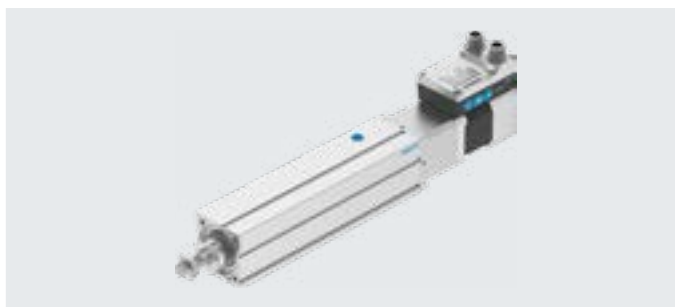

General technical data		32		45		60	
Size							
Design		Electric cylinder with ball screw					
Motor type		Stepper motor					
Protection against rotation/guide		With plain-bearing guide					
Mounting position		Any					
Piston rod thread		M8		M10x1.25		M12x1.25	
Piston rod end		Male thread					
Working stroke	[mm]	25, 50, 75, 100, 125, 150, 175, 200		25, 50, 75, 100, 125, 150, 175, 200, 250, 300		25, 50, 75, 100, 125, 150, 175, 200, 250, 300, 350, 400, 500	
Stroke reserve	[mm]	0					
Max. angle of rotation of the piston rod	[°]	≤ ±1					
Additional functions		Built-in end-position sensing					
		User interface					
Display		LED					
Homing		Positive fixed stop block					
		Negative fixed stop block					
Type of mounting		Via female thread					
		Via accessories					
Max. cable length							
Inputs/outputs	[m]	15					
IO-Link® operation	[m]	20					

Mechanical data		32		45		60	
Size							
Spindle design		3P	8P	3P	10P	5P	12P
Spindle pitch	[mm/rev]	3	8	3	10	5	12
Spindle diameter	[mm]	8	8	10	10	12	12
Max. payload							
Horizontal	[kg]	24	24	60	40	120	56
Vertical	[kg]	12	9	23	13	46	18
Max. feed force F_x	[N]	150	150	450	250	900	375
Max. radial force ¹⁾	[N]	75	75	180	180	230	230
Repetition accuracy	[mm]	±0.02					
Reversing backlash ²⁾	[mm]	≤ 0.1					
Position sensing		Via proximity switch					
		Via IO-Link®					
With axial motor mounting							
Max. speed ³⁾	[m/s]	0.079	0.21	0.074	0.23	0.09	0.22
Speed "Speed Press" ⁴⁾	[m/s]	0.01					
Max. acceleration ⁴⁾	[m/s ²]	1.5	5	1.5	5	1.5	5
With parallel motor mounting							
Max. speed ³⁾	[m/s]	0.75	0.2	0.07	0.22	0.09	0.21
Speed "Speed Press" ⁴⁾	[m/s]	0.01					
Max. acceleration ⁴⁾	[m/s ²]	0.5	1.5	0.5	1.5	0.5	1.5

- 1) At the drive shaft
- 2) When new
- 3) Adjustable in increments of 10%
- 4) Unchangeable parameter

Datasheet

Electrical data			
Size		32	45 60
Motor			
Nominal voltage DC	[V]	24 (±15%)	
Nominal current	[A]	3	3 5.3
Max. current consumption (load)	[A]	3	3 5.3
Max. current consumption (logic)	[mA]	300	
Encoder			
Rotor position sensor		Absolute encoder, single turn	
Rotor position sensor measuring principle		Magnetic	
Rotor position sensor resolution	[Bit]	16	
Interfaces			
Size		32	45 60
Parameterisation interface			
IO-Link®		Yes	
User interface		Yes	
Digital inputs			
Number		2	
Switching logic		PNP	
		NPN	
Characteristics		Not galvanically isolated	
		Configurable	
Specification		Based on IEC 61131-2, type 1	
Operating range	[V]	24	
Digital outputs			
Number		2	
Switching logic		PNP	
		NPN	
Rotor position sensor		Absolute encoder, single turn	
Characteristics		Not galvanically isolated	
		Configurable	
Max. current	[mA]	100	

Datasheet

Technical data – IO-Link®				
Size		32	45	60
SIO mode support		Yes		
Communication mode		COM3 (230.4 kBd)		
Connection technology		Plug		
Port class		A		
Number of ports		1		
Process data length OUT	[byte]	2		
Process data content OUT	[bit]	1 (Move in)		
	[bit]	1 (Move out)		
	[bit]	1 (Move Intermediate)		
	[bit]	1 (Quit Error)		
Process data length IN	[byte]	2		
Process data content IN	[bit]	1 (State Device)		
	[bit]	1 (State Move)		
	[bit]	1 (State in)		
	[bit]	1 (State out)		
	[bit]	1 (State Intermediate)		
Service data content IN	[bit]	32 (Force)		
	[bit]	32 (Position)		
	[bit]	32 (Speed)		
Minimum cycle time	[ms]	1		
Data memory required	[kilobyte]	0.5		
Protocol version		Device V 1.1		

Operating and environmental conditions				
Size		32	45	60
Insulation class		B		
Ambient temperature	[°C]	0 ... +50		
Storage temperature	[°C]	-20 ... +60		
Note on ambient temperature		Above an ambient temperature of 30°C, the power must be reduced by 2% per K		
Temperature monitoring		Switch-off in the event of over-temperature		
		Integrated precise CMOS temperature sensor with analogue output		
Relative humidity	[%]	0 ... 90 (non-condensing)		
Protection class		III		
Degree of protection		IP40		
Duty cycle	[%]	100		
CE marking		To EU EMC Directive for EMCS-ST → festo.com/sp		
		To EU RoHS Directive		
UKCA marking (see declaration of conformity)		To UK EMC regulations		
KC marking		KC EMC		
Certification		RCM		
Vibration resistant		Transport application test with severity level 1 to FN 942017-4 and EN 61800-2 and EN 61800-5-1		
Shock resistance		Shock test with severity level 1 to FN 942017-5 and EN 61800-2		
Maintenance interval		Lifetime lubrication		

Weight				
Size		32	45	60
With axial motor mounting				
Basic weight with 0 mm stroke	[g]	818	1185	2294
Additional weight per 10 mm stroke	[g]	24	41	69
Moving mass with 0 mm stroke	[g]	98	179	305
Additional moving mass per 10 mm stroke	[g]	3.3	4.9	6.5
With parallel motor mounting				
Basic weight with 0 mm stroke	[g]	982	1308	2558
Additional weight per 10 mm stroke	[g]	24	41	69
Moving mass with 0 mm stroke	[g]	98	179	305
Additional moving mass per 10 mm stroke	[g]	3.3	4.9	6.5

Datasheet

Materials

Sectional view

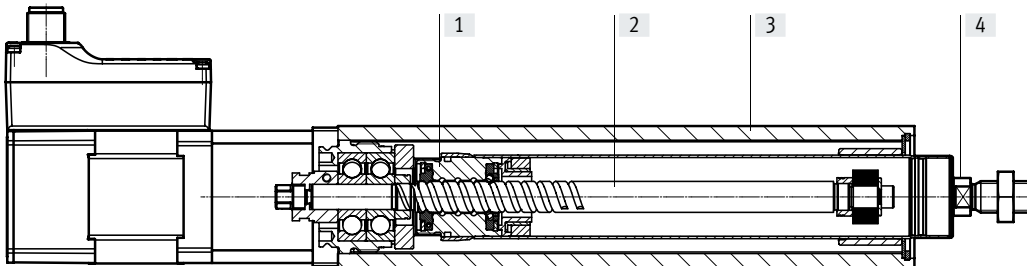

Electric cylinder

[1]	Spindle nut	Steel
[2]	Spindle	Roller bearing steel
[3]	Housing	Smooth-anodised wrought aluminium alloy
[4]	Piston rod	High-alloy stainless steel
Note on materials		RoHS-compliant
LABS (PWIS) conformity		VDMA24364 zone III

Pin allocation

Power supply

Plug

M12x1, 4-pin, T-coded to EN 61076-2-111

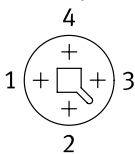

Pin	Function
1	Power voltage supply (24 V DC)
2	Reference potential, power voltage supply (GND)
3	Reserved, do not connect
4	Functional earth (FE)

Logic interface

Plug

M12x1, 8-pin, A-coded to EN 61076-2-101

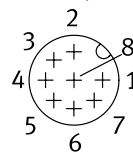

When used with digital I/O

Pin	Function
1	Logic voltage supply (24 V DC)
2	Digital output 1 (State "In")
3	Digital output 2 (State "Out")
4	Reference potential, logic voltage supply (GND)
5	Digital input 1 (Move "In")
6	Digital input 2 (Move "Out")
7	Reserved, do not connect
8	Reference potential, logic voltage supply (GND)

When used with IO-Link®

Pin	Function
1	L+ IO-Link® power supply (24 V DC)
2	Reserved, do not connect
3	C/Q communication with the IO-Link master
4	L – Reference potential, IO-Link® power supply (0 V)
5	Reserved, do not connect
6	Reserved, do not connect
7	Reserved, do not connect
8	L – Reference potential, IO-Link® power supply (0 V)

Datasheet

Maximum permissible loads on the piston rod

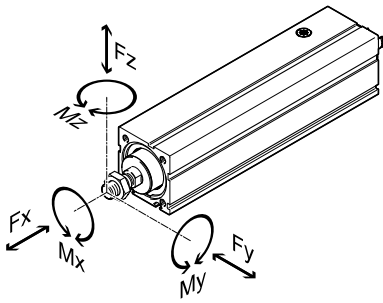

If there are two or more forces and torques simultaneously acting on the piston rod, the following equations must be satisfied:

- $F_1/M_1 = \text{dynamic value}$
- $F_2/M_2 = \text{maximum value}$

$$f_v = \frac{|F_{y1}|}{F_{y2}} + \frac{|F_{z1}|}{F_{z2}} + \frac{|M_{y1}|}{M_{y2}} + \frac{|M_{z1}|}{M_{z2}} \leq 1$$

$$|Fx| \leq Fx_{max}$$

$$|Mx| \leq Mx_{max}$$

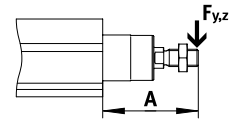

Maximum permissible lateral forces $F_{y_{max}}$ and $F_{z_{max}}$ on the piston rod as a function of projection A

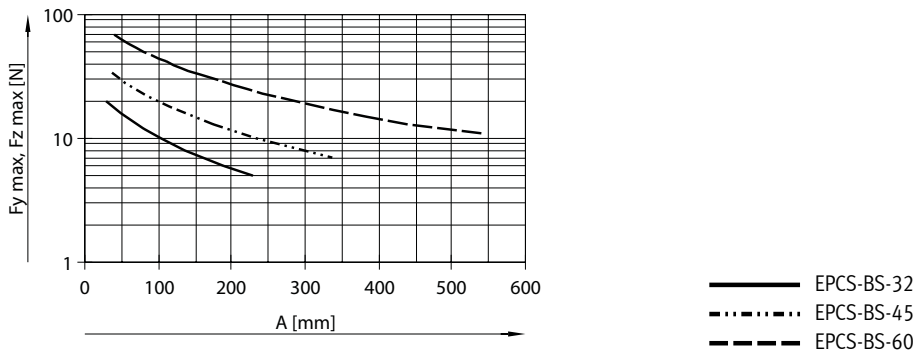

Size	32		45		60	
	3P	8P	3P	10P	5P	12P
$F_{x_{max}}$ (static) [N]	150	150	450	450	1000	1000
$M_{x_{max}}$ [Nm]	0					
$M_{y_{max}}, M_{z_{max}}$ [Nm]	1.5		2.9		6.4	

Note
 Engineering software
 Electric Motion Sizing
 → www.festo.com/x/electric-motion-sizing

Datasheet

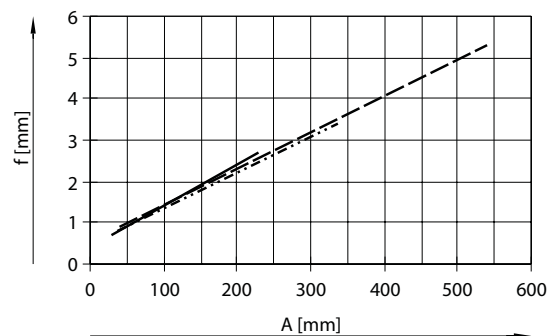
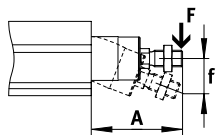
Piston rod deflection f_2 as a function of projection A and lateral force F

- EPCS-BS-32 ($F_2 = 3.5 \text{ N}$)
- ⋯ EPCS-BS-45 ($F_2 = 4.0 \text{ N}$)
- - - EPCS-BS-60 ($F_2 = 8.0 \text{ N}$)

$$f_1 = \frac{F_1}{F_2} \cdot f_2$$

f_1 = Piston rod deflection caused by lateral force [mm]

F_1 = Lateral force [N]

F_2 = Standardised lateral force [N] (constant force from graph)

f_2 = Piston rod deflection caused by lateral force [N]
(reading from graph)

Example: Electric cylinder EPCS-32-50-8P with a lateral force of 7 N
 $F_1 = 7 \text{ N}$ and $F_{\text{standard}} = 3.5 \text{ N}$

Value read from graph for EPCS-32 and projection = 50 mm

$f_2 = 1 \text{ mm}$

Calculation of deflection caused by lateral force:

$$f_1 = \frac{F_1}{F_2} \cdot f_2 = \frac{7 \text{ N}}{3.5 \text{ N}} \cdot 1 \text{ mm} = 2 \text{ mm}$$

Datasheet

Calculating the mean feed force F_{xm} with the electric cylinder EPCS

The peak feed force value must not exceed the maximum feed force within a movement cycle. The peak value is generally achieved in vertical operation during the acceleration phase of the upwards stroke. If the maximum feed force is exceeded, this can increase wear and thus shorten the service life of the ball screw. The maximum speed must likewise not be exceeded:

$$F_x \leq F_{xmax}$$

and

$$V_x \leq V_{xmax}$$

Calculating the mean feed force F_{xm} (to DIN 69051-4)

During operation, the continuous feed force may be briefly exceeded up to the maximum feed force. The continuous feed force must, however, be adhered to when averaged over a movement cycle:

$$F_{xm} \leq F_{xcontinuous}$$

$$F_{xm} = \sqrt[3]{\sum F_x^3 \cdot \frac{v_x}{v_{xm}} \cdot \frac{q}{100}} =$$

$$F_{xm} = \sqrt[3]{F_{x1}^3 \cdot \frac{v_{x1}}{v_{xm}} \cdot \frac{q_1}{100} + F_{x2}^3 \cdot \frac{v_{x2}}{v_{xm}} \cdot \frac{q_2}{100} + F_{x3}^3 \cdot \frac{v_{x3}}{v_{xm}} \cdot \frac{q_3}{100} + \dots}$$

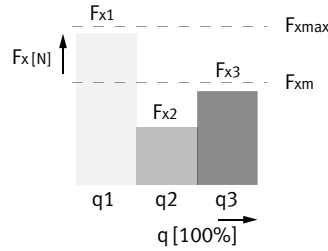

Mean feed speed (to DIN 69051-4)

$$v_{xm} = \sum v_x \cdot \frac{q}{100} = v_{x1} \cdot \frac{q_1}{100} + v_{x2} \cdot \frac{q_2}{100} + v_{x3} \cdot \frac{q_3}{100} + \dots$$

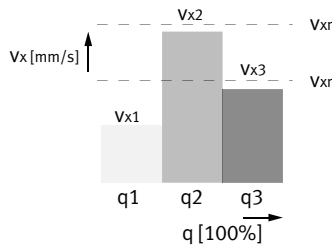

- F_x Feed force
- F_{xm} Mean feed force
- F_{xmax} Max. feed force
- $F_{xcontinuous}$ Continuous feed force
- q Time
- v_x Feed speed
- v_{xm} Mean feed speed
- v_{xmax} Max. Feed speed

Datasheet

Mean feed force F_{xm} as a function of running performance L, with an operating coefficient f_B of 1.0 at room temperature

Size 32

Size 45

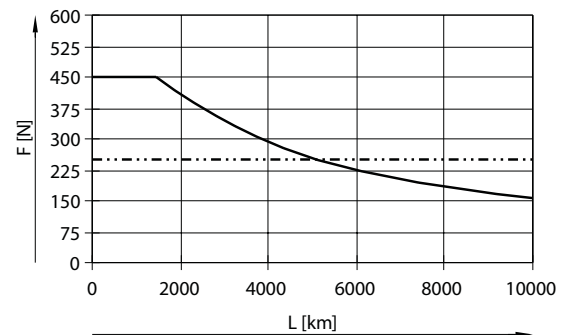
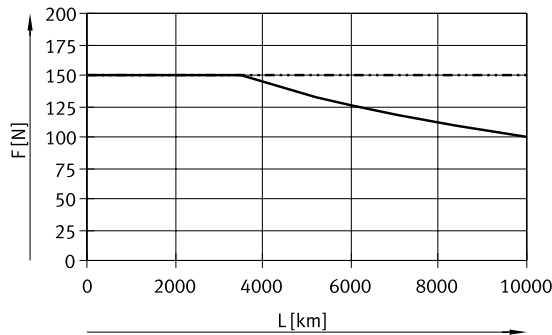

— EPCS-BS-32-3P
- - - - - EPCS-BS-32-8P

— EPCS-BS-45-3P
- - - - - EPCS-BS-45-10P

Size 60

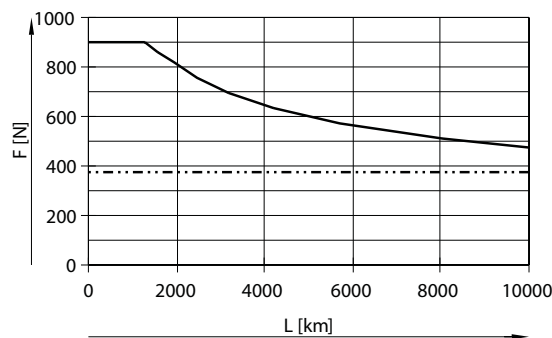

— EPCS-BS-60-5P
- - - - - EPCS-BS-60-12P

$$L_1 = \frac{L}{f_B^3}$$

L_1 Actual service life
L Target service life
(→ graphs)
 f_B Operating coefficient

Service life taking into account the operating coefficient

Load ¹⁾	Operating coefficient f_B	Sample application
None	1.0 ... 1.2	Measuring machine
Light	1.2 ... 1.4	Handling, robot technology
Medium	1.4 ... 1.6	Press-in operations
High	1.6 ... 2.0	Construction, agriculture

1) This refers to stress caused by impact, temperature, contamination, shock and vibrations that affect the cylinder or piston rod.

Note

The specifications for running performance are based on experimentally determined and theoretically calculated data (at room temperature). The running performance that can be achieved in practice can deviate considerably from the specified curves under different parameters.

Datasheet

Sizing example

Application data:

- Payload: 25 kg
- Mounting position: horizontal
- Motor mounting position: axial
- Stroke: 150 mm
- Max. permissible positioning time: 2 s (one direction)

Step 1: Selecting the smallest possible size from the table → page 10

Mechanical data

Size		32		45		60	
Spindle design		3P	8P	3P	10P	5P	12P
Max. payload							
Horizontal	[kg]	24	24	60	40	120	56
Vertical	[kg]	12	9	23	13	46	18

→ Smallest possible size: EPCS-BS-45-10P

Step 2: Selecting the max. speed level v for payload m

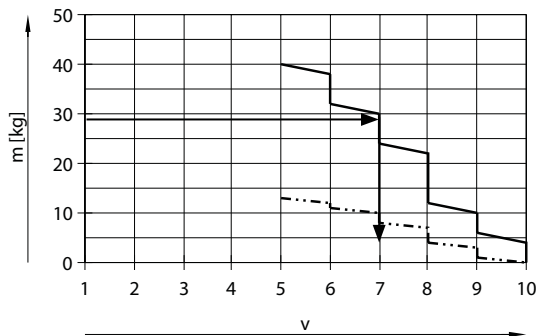

— Horizontal
- - - Vertical

→ Max. speed level for the payload: level 7

Step 3: Reading off the min. positioning time t for stroke l

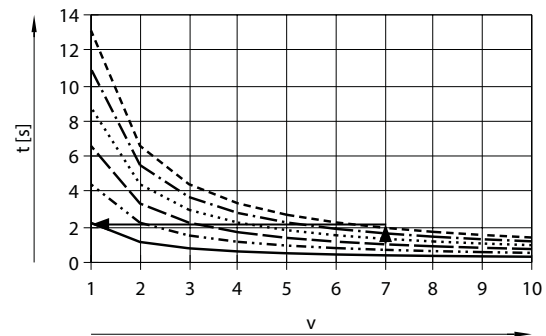

— l = 50 mm
..... l = 100 mm
- - - l = 150 mm
- · - · l = 200 mm
- - - l = 250 mm
- - - l = 300 mm

→ Min. positioning time for 150 mm at level 7: 1 s

Result

The application can be implemented using EPCS-BS-45-150-10P. A minimum positioning time (one direction) of 1 s is achieved. Longer positioning times can be selected at any time using a lower speed level.

Datasheet

Mass m as a function of speed level v

With axial kit

EPCS-BS-32-3P

EPCS-BS-32-8P

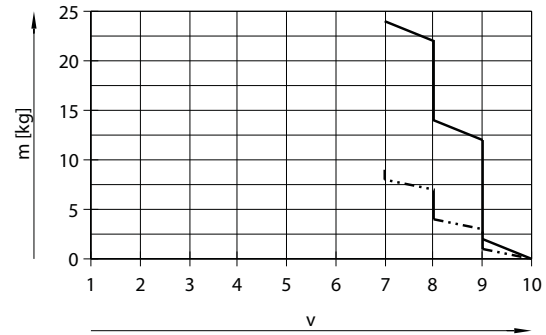
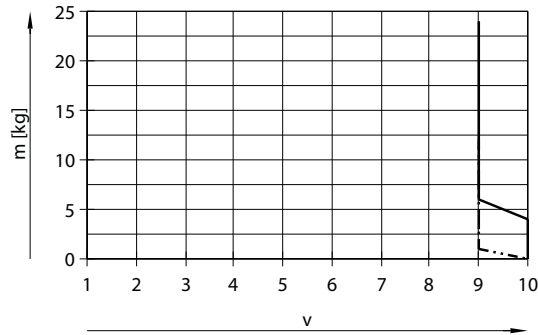

— Horizontal
- - - - Vertical

EPCS-BS-45-3P

EPCS-BS-45-10P

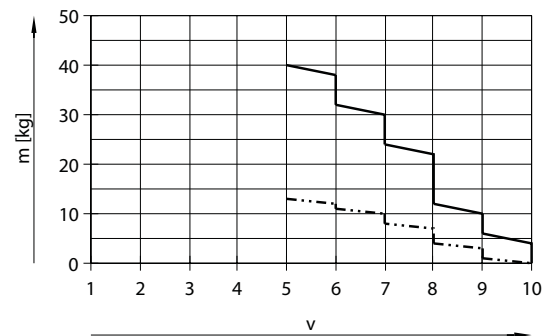
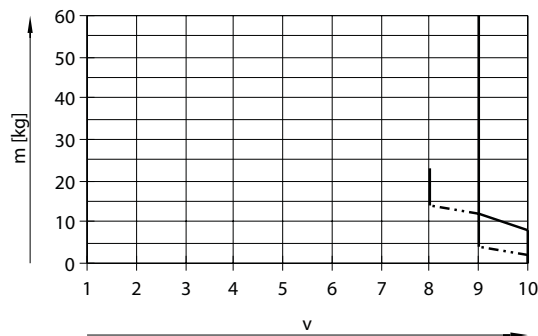

— Horizontal
- - - - Vertical

EPCS-BS-60-5P

EPCS-BS-60-12P

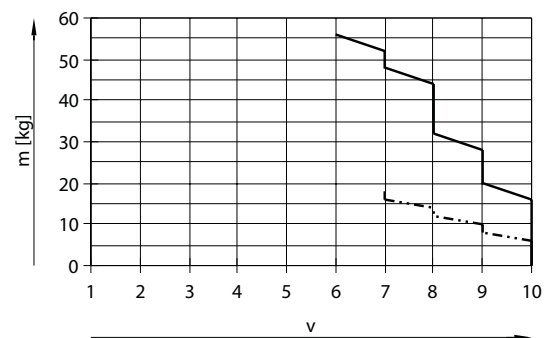
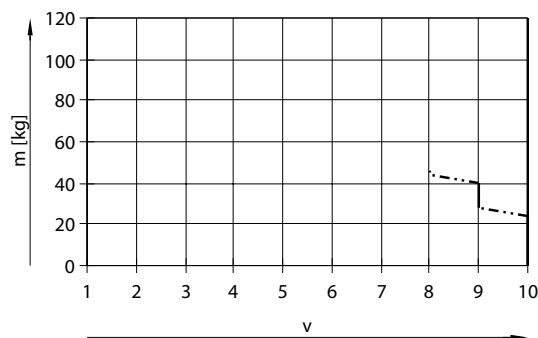

— Horizontal
- - - - Vertical

- - - - Note
The lines represent the maximum values. The lower speed levels can be set at any time.

Datasheet

Positioning time t as a function of speed level v and stroke l

With axial kit

EPCS-BS-32-3P

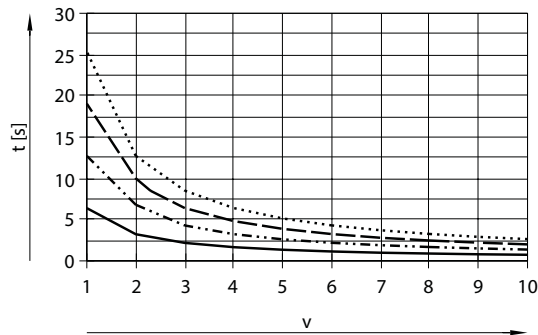

- $l = 50$ mm
- $l = 100$ mm
- - - $l = 150$ mm
- · - · $l = 200$ mm

EPCS-BS-32-8P

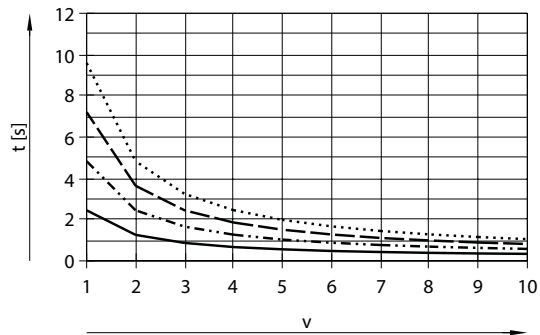

- $l = 50$ mm
- $l = 100$ mm
- - - $l = 150$ mm
- · - · $l = 200$ mm

EPCS-BS-45-3P

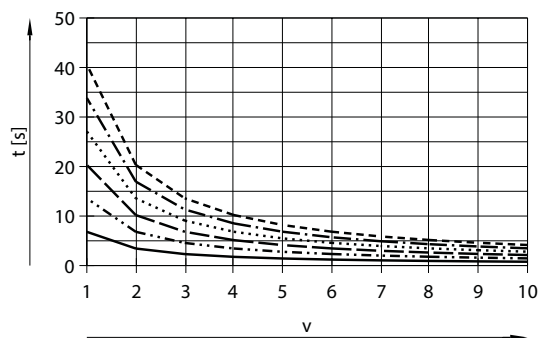

- $l = 50$ mm
- $l = 100$ mm
- - - $l = 150$ mm
- · - · $l = 200$ mm
- - - - $l = 250$ mm
- - - - $l = 300$ mm

EPCS-BS-45-10P

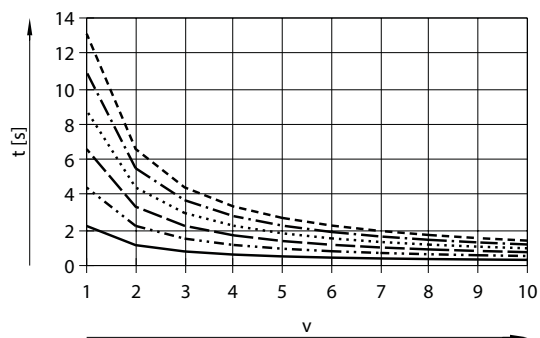

- $l = 50$ mm
- $l = 100$ mm
- - - $l = 150$ mm
- · - · $l = 200$ mm
- - - - $l = 250$ mm
- - - - $l = 300$ mm

Datasheet

Positioning time t as a function of speed level v and stroke l

With axial kit

EPCS-BS-60-5P

EPCS-BS-60-12P

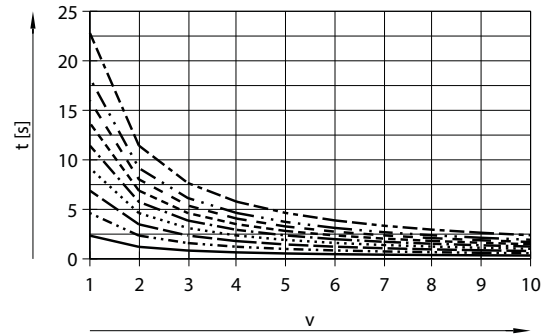
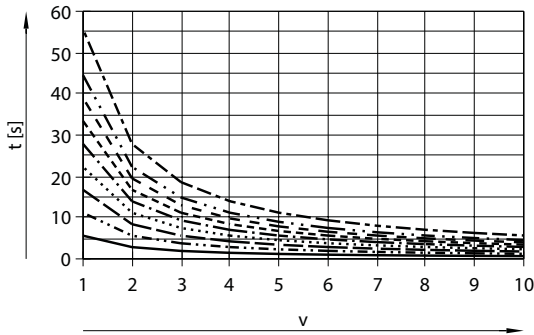

- $l = 50$ mm
- · - · - $l = 100$ mm
- - - $l = 150$ mm
- · · · · $l = 200$ mm
- · - · - $l = 250$ mm
- - - $l = 300$ mm
- - - $l = 350$ mm
- · - · - $l = 400$ mm
- · - · - $l = 500$ mm

- $l = 50$ mm
- · - · - $l = 100$ mm
- - - $l = 150$ mm
- · · · · $l = 200$ mm
- · - · - $l = 250$ mm
- - - $l = 300$ mm
- - - $l = 350$ mm
- · - · - $l = 400$ mm
- · - · - $l = 500$ mm

Datasheet

Mass m as a function of speed level v

With parallel kit

EPCS-BS-32-3P

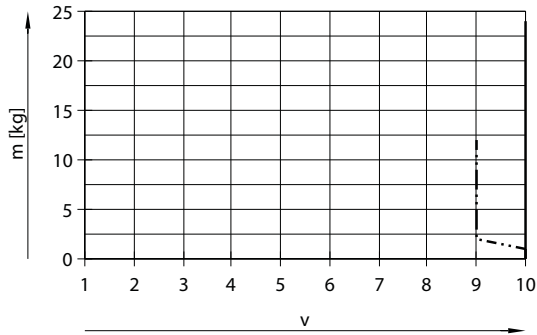

EPCS-BS-32-8P

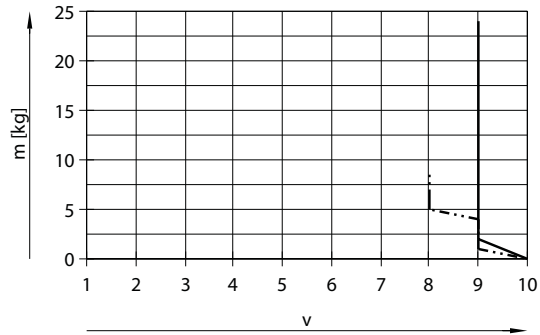

— Horizontal
- · · · · Vertical

EPCS-BS-45-3P

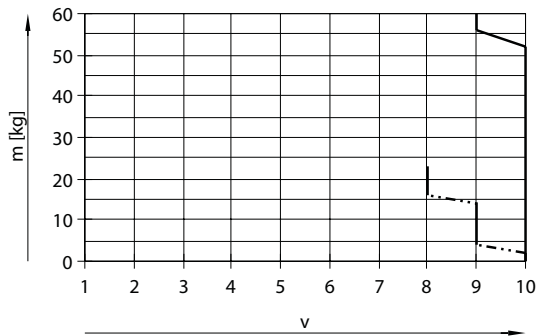

EPCS-BS-45-10P

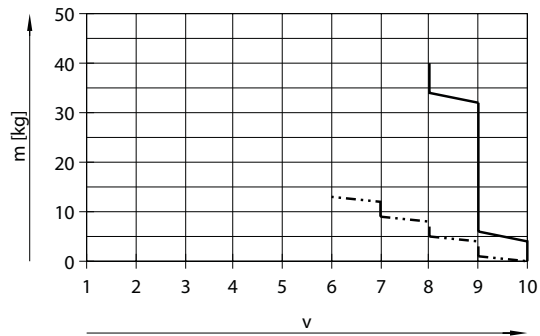

— Horizontal
- · · · · Vertical

EPCS-BS-60-5P

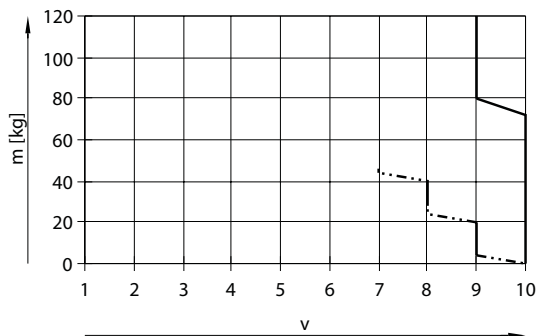

EPCS-BS-60-12P

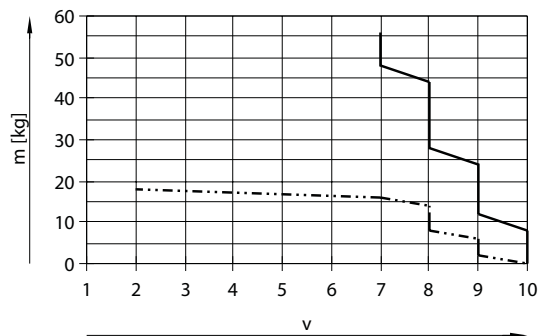

— Horizontal
- · · · · Vertical

-  - Note
The lines represent the maximum values. The lower speed levels can be set at any time.

Datasheet

Positioning time t as a function of speed level v and stroke l

With parallel kit

EPCS-BS-32-3P

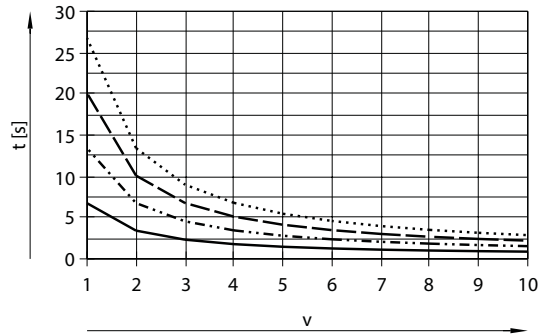

- $l = 50$ mm
- $l = 100$ mm
- - - $l = 150$ mm
- · - · $l = 200$ mm

EPCS-BS-32-8P

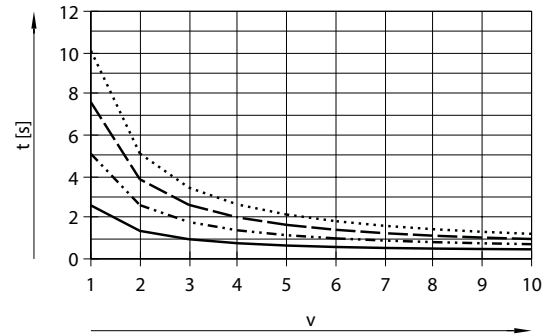

- $l = 50$ mm
- $l = 100$ mm
- - - $l = 150$ mm
- · - · $l = 200$ mm

EPCS-BS-45-3P

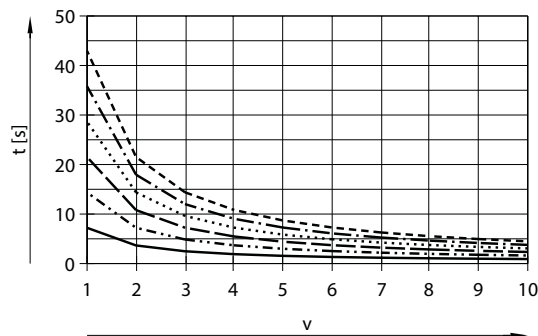

- $l = 50$ mm
- $l = 100$ mm
- - - $l = 150$ mm
- · - · $l = 200$ mm
- - - - $l = 250$ mm
- - - - $l = 300$ mm

EPCS-BS-45-10P

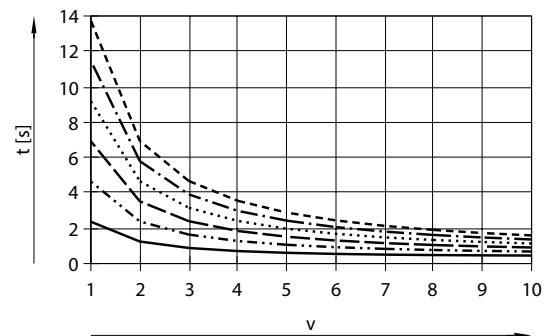

- $l = 50$ mm
- $l = 100$ mm
- - - $l = 150$ mm
- · - · $l = 200$ mm
- - - - $l = 250$ mm
- - - - $l = 300$ mm

Datasheet

Positioning time t as a function of speed level v and stroke l

With parallel kit

EPCS-BS-60-5P

EPCS-BS-60-12P

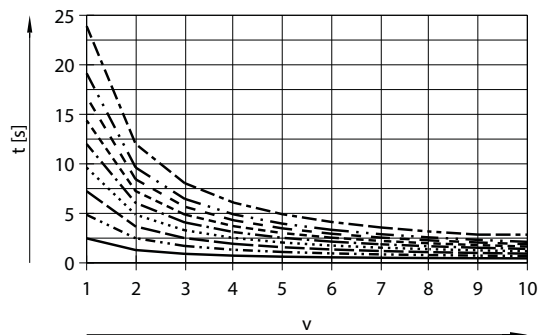
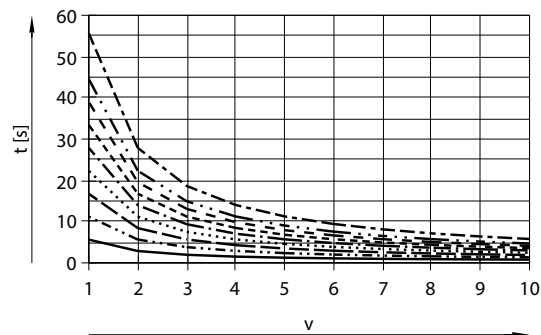

- $l = 50$ mm
- · - · - $l = 100$ mm
- - - $l = 150$ mm
- · · · · $l = 200$ mm
- · - · - $l = 250$ mm
- - - $l = 300$ mm
- - - $l = 350$ mm
- · - · - $l = 400$ mm
- · - · - $l = 500$ mm

- $l = 50$ mm
- · - · - $l = 100$ mm
- - - $l = 150$ mm
- · · · · $l = 200$ mm
- · - · - $l = 250$ mm
- - - $l = 300$ mm
- - - $l = 350$ mm
- · - · - $l = 400$ mm
- · - · - $l = 500$ mm

Feed force F as a function of force level F_1

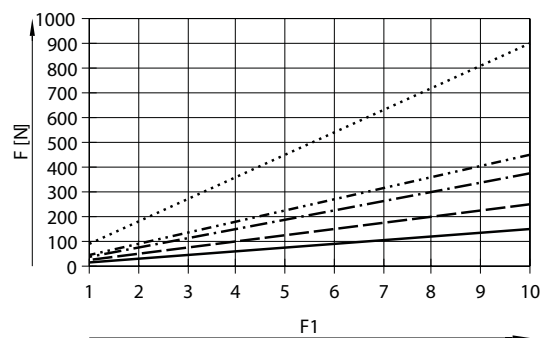

- EPCS-BS-32-3P/-8P
- · - · - EPCS-BS-45-3P
- - - EPCS-BS-45-10P
- · · · · EPCS-BS-60-5P
- · - · - EPCS-BS-60-12P

Datasheet

Dimensions – With axial motor

Download CAD data → www.festo.com

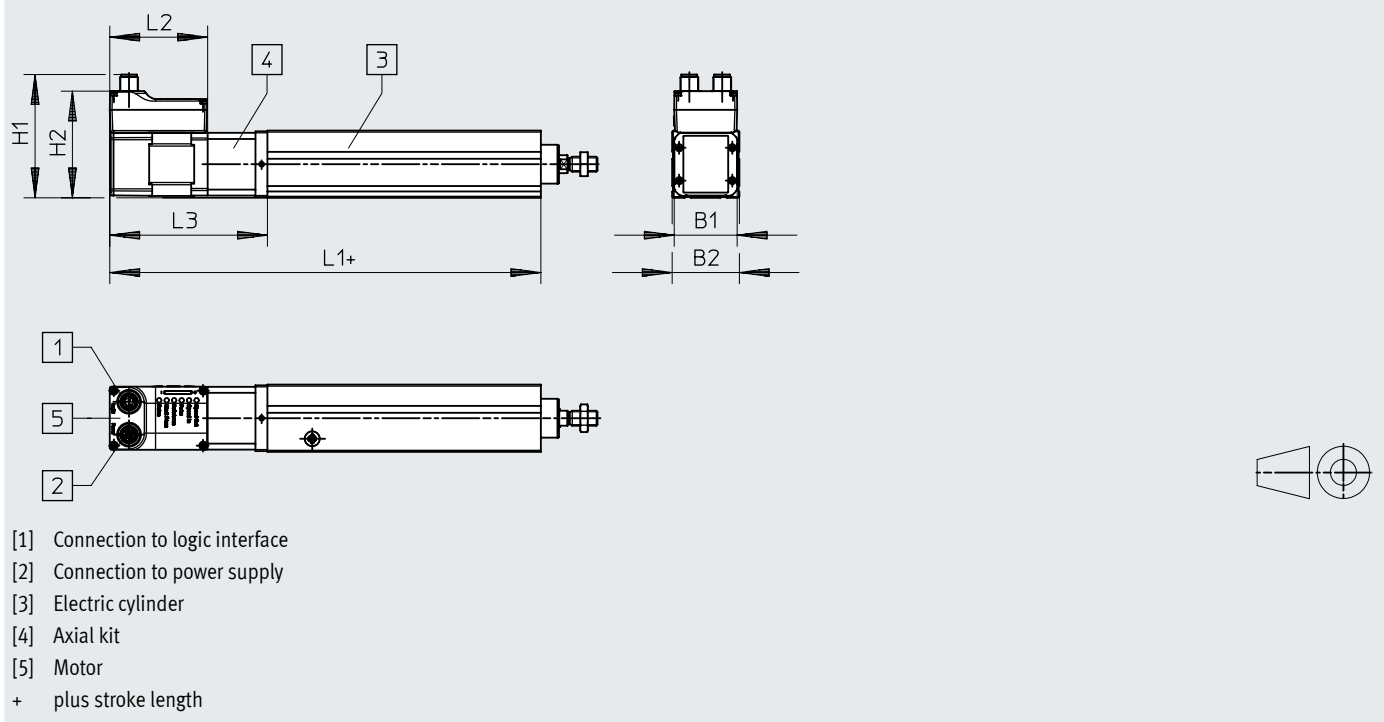

Size	B1	B2	H1	H2	L1	L2	L3
32	42.3	32	81.1	69.9	175.5	65.5	105.5
45	42.3	45	82.6	71.4	188.5	65.5	105.5
60	56.6	60	97.3	86.1	216.5	73.5	116.5

Datasheet

Dimensions – With parallel motor

Download CAD data → www.festo.com

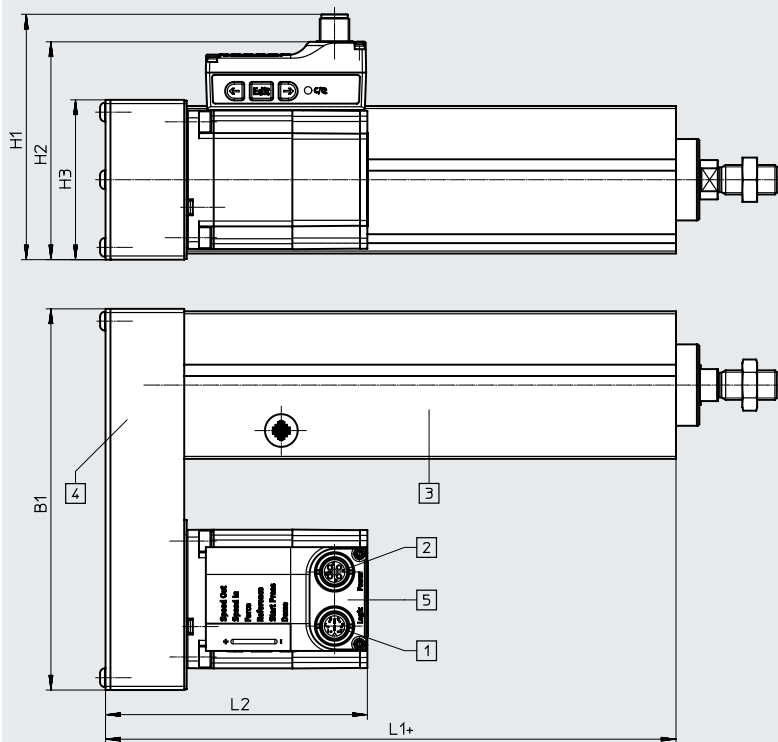

- [1] Connection to logic interface
- [2] Connection to power supply
- [3] Electric cylinder
- [4] Parallel kit
- [5] Motor
- + plus stroke length

Dimensions for other motor mounting variants → CAD data.

Size	B1	H1	H2	H3	L1	L2
32	111	83	72	45	94	90.7
45	111	83	72	45	107	90.7
60	155	100	90	65	132	107.7

Datasheet

Dimensions – Mechanical system

Download CAD data → www.festo.com

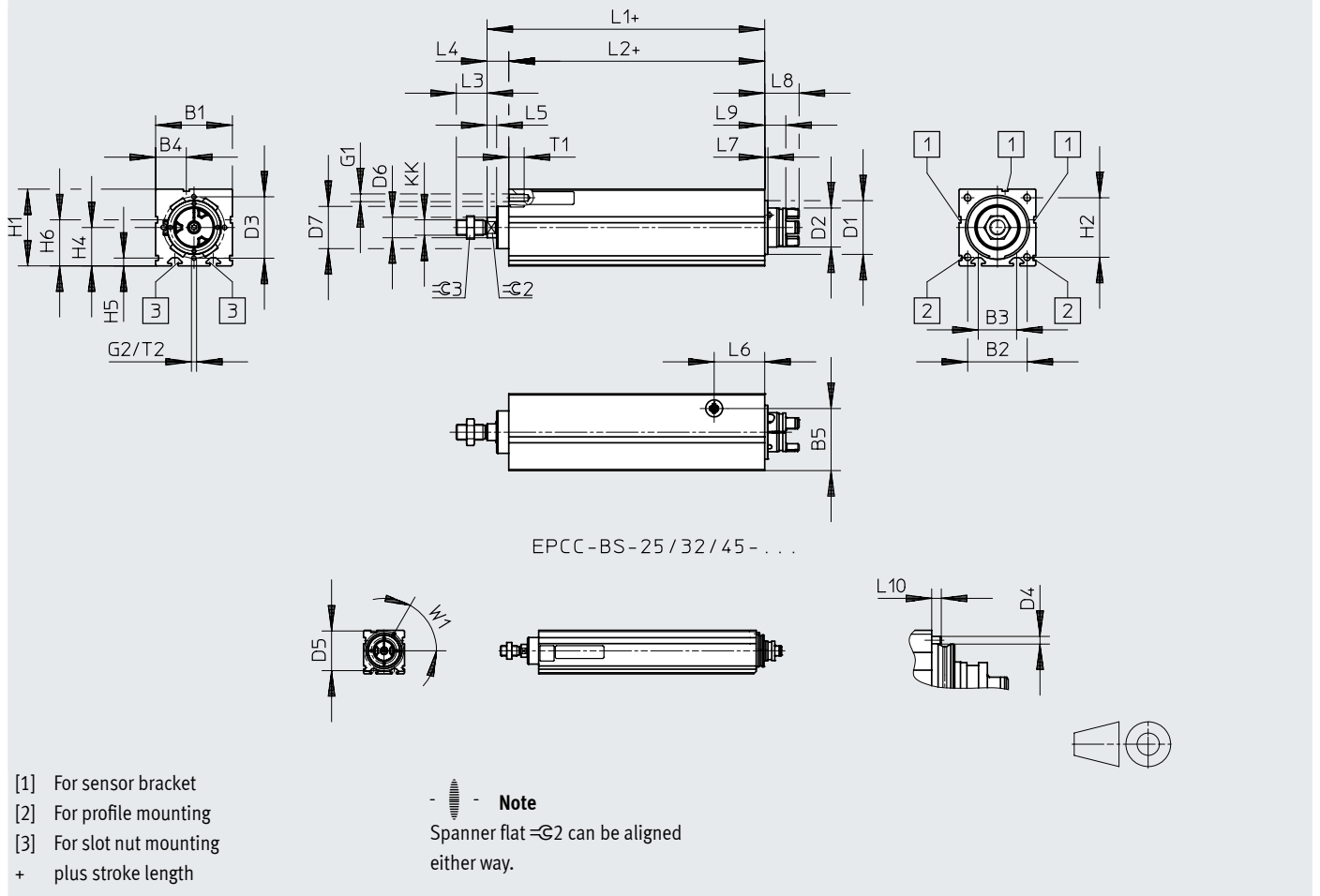

Size	B1	B2	B3	B4	B5	D1	D2	D3	D4
	± 0.15					\emptyset	\emptyset	\emptyset	\emptyset
32	32	24	16	8.1	25.5	25	15.5	-	2
45	45	32.5	24	16.5	35	32	16.3	-	3
60	60	46.5	30	24	48.5	42	31.4	48	-

Size	D5	D6	D7	G1	G2	H1	H2	H4	H5
	\emptyset	\emptyset	\emptyset			± 0.15			
32	31	10	21.3	M4	-	34	24	-	4.9
45	41	12	26.5	M5	-	45	32.5	-	6.1
60	-	16	33.6	M6	M4	60	46.5	30	6.1

Size	H6	KK	L1	L2	L3	L4	L5	L6	L7
	$+0.15$								
32	26	M8	82.9	70	16	12.9	5.2	24.2	6
45	28.5	M10x1.25	99.9	83	20	16.9	5.7	30.5	6
60	36	M12x1.25	116	100	24	16	7.5	39.5	2.5

Size	L8	L9	L10	T1	T2	W1	± 0.02	± 0.03
32	19.9	14.5	2.5	8	-	60°	9	13
45	19.9	14.5	3	10	-	60°	10	16
60	26.9	16.5	-	12	10	-	13	18

Datasheet

Ordering data

EPCS-BS-32

Stroke [mm]	Part no.	Type
Spindle pitch 3 mm/rev		
50	8118267	EPCS-BS-32-50-3P-A-ST-M-H1-PLK-AA
100	8118268	EPCS-BS-32-100-3P-A-ST-M-H1-PLK-AA
150	8118269	EPCS-BS-32-150-3P-A-ST-M-H1-PLK-AA
200	8118270	EPCS-BS-32-200-3P-A-ST-M-H1-PLK-AA

Stroke [mm]	Part no.	Type
Spindle pitch 8 mm/rev		
50	8118271	EPCS-BS-32-50-8P-A-ST-M-H1-PLK-AA
100	8118272	EPCS-BS-32-100-8P-A-ST-M-H1-PLK-AA
150	8118273	EPCS-BS-32-150-8P-A-ST-M-H1-PLK-AA
200	8118274	EPCS-BS-32-200-8P-A-ST-M-H1-PLK-AA

EPCS-BS-45

Stroke [mm]	Part no.	Type
Spindle pitch 3 mm/rev		
50	8118275	EPCS-BS-45-50-3P-A-ST-M-H1-PLK-AA
100	8118276	EPCS-BS-45-100-3P-A-ST-M-H1-PLK-AA
150	8118277	EPCS-BS-45-150-3P-A-ST-M-H1-PLK-AA
200	8118278	EPCS-BS-45-200-3P-A-ST-M-H1-PLK-AA
250	8118279	EPCS-BS-45-250-3P-A-ST-M-H1-PLK-AA
300	8118280	EPCS-BS-45-300-3P-A-ST-M-H1-PLK-AA

Stroke [mm]	Part no.	Type
Spindle pitch 10 mm/rev		
50	8118281	EPCS-BS-45-50-10P-A-ST-M-H1-PLK-AA
100	8118282	EPCS-BS-45-100-10P-A-ST-M-H1-PLK-AA
150	8118283	EPCS-BS-45-150-10P-A-ST-M-H1-PLK-AA
200	8118284	EPCS-BS-45-200-10P-A-ST-M-H1-PLK-AA
250	8118285	EPCS-BS-45-250-10P-A-ST-M-H1-PLK-AA
300	8118286	EPCS-BS-45-300-10P-A-ST-M-H1-PLK-AA

EPCS-BS-60

Stroke [mm]	Part no.	Type
Spindle pitch 5 mm/rev		
50	8118287	EPCS-BS-60-50-5P-A-ST-M-H1-PLK-AA
100	8118288	EPCS-BS-60-100-5P-A-ST-M-H1-PLK-AA
150	8118289	EPCS-BS-60-150-5P-A-ST-M-H1-PLK-AA
200	8118290	EPCS-BS-60-200-5P-A-ST-M-H1-PLK-AA
250	8118291	EPCS-BS-60-250-5P-A-ST-M-H1-PLK-AA
300	8118292	EPCS-BS-60-300-5P-A-ST-M-H1-PLK-AA
350	8118293	EPCS-BS-60-350-5P-A-ST-M-H1-PLK-AA
400	8118294	EPCS-BS-60-400-5P-A-ST-M-H1-PLK-AA
500	8118295	EPCS-BS-60-500-5P-A-ST-M-H1-PLK-AA

Stroke [mm]	Part no.	Type
Spindle pitch 12 mm/rev		
50	8118296	EPCS-BS-60-50-12P-A-ST-M-H1-PLK-AA
100	8118297	EPCS-BS-60-100-12P-A-ST-M-H1-PLK-AA
150	8118298	EPCS-BS-60-150-12P-A-ST-M-H1-PLK-AA
200	8118299	EPCS-BS-60-200-12P-A-ST-M-H1-PLK-AA
250	8118300	EPCS-BS-60-250-12P-A-ST-M-H1-PLK-AA
300	8118301	EPCS-BS-60-300-12P-A-ST-M-H1-PLK-AA
350	8118302	EPCS-BS-60-350-12P-A-ST-M-H1-PLK-AA
400	8118303	EPCS-BS-60-400-12P-A-ST-M-H1-PLK-AA
500	8118304	EPCS-BS-60-500-12P-A-ST-M-H1-PLK-AA

Ordering data – Modular product system

Ordering table						
Size	32	45	60	Conditions	Code	Enter code
Module no.	8118264	8118265	8118266			
Series	EPCS				EPCS	EPCS
Drive system	Ball screw				-BS	-BS
Size	32	45	60		-...	
Stroke [mm]	25, 50, 75, 100, 125, 150, 175, 200	25, 50, 75, 100, 125, 150, 175, 200, 250, 300	25, 50, 75, 100, 125, 150, 200, 250, 300, 350, 400, 500		-...	
Spindle pitch [mm]	3	3	-		-...P	
	-	-	5			
	8	-	-			
	-	10	-			
	-	-	12			
Position sensing	Via proximity switch				-A	-A
Motor type	Stepper motor ST				-ST	-ST
Controller	Built in				-M	-M
Operator panel	Built in				-H1	-H1
Bus protocol/activation	NPN and IO-Link®				-NLK	
	PNP and IO-Link®				-PLK	
End-position detection	With integrated end-position sensing				-AA	-AA
Cable outlet direction	Standard			[1]		
	To the left			[2]	-L	
	Underneath			[3]	-D	
	To the right			[4]	-R	
Motor attachment position	Axial (standard)					
	Parallel, left			[5]	-PL	
	Parallel, right			[6]	-PR	
	Parallel, underneath			[7]	-PD	
	Parallel, top			[8]	-PT	
Electrical accessories	None					
	Adapter for operation as IO device				+L1	
Operating instructions	With operating instructions					
	Without operating instructions				DN	

- [1] Not with motor mounting position PD
 [2] Not with motor mounting position PR
 [3] Not with motor mounting position PT
 [4] Not with motor mounting position PL
 [5] Not in combination with cable outlet direction R
 [6] Not in combination with cable outlet direction L
 [7] Not in combination with cable outlet direction standard
 [8] Not in combination with cable outlet direction D

Accessories

Profile mounting EAHF-L2-...-P-S

Material:

Anodised wrought aluminium alloy

RoHS-compliant

- For mounting the cylinder on the side of the profile

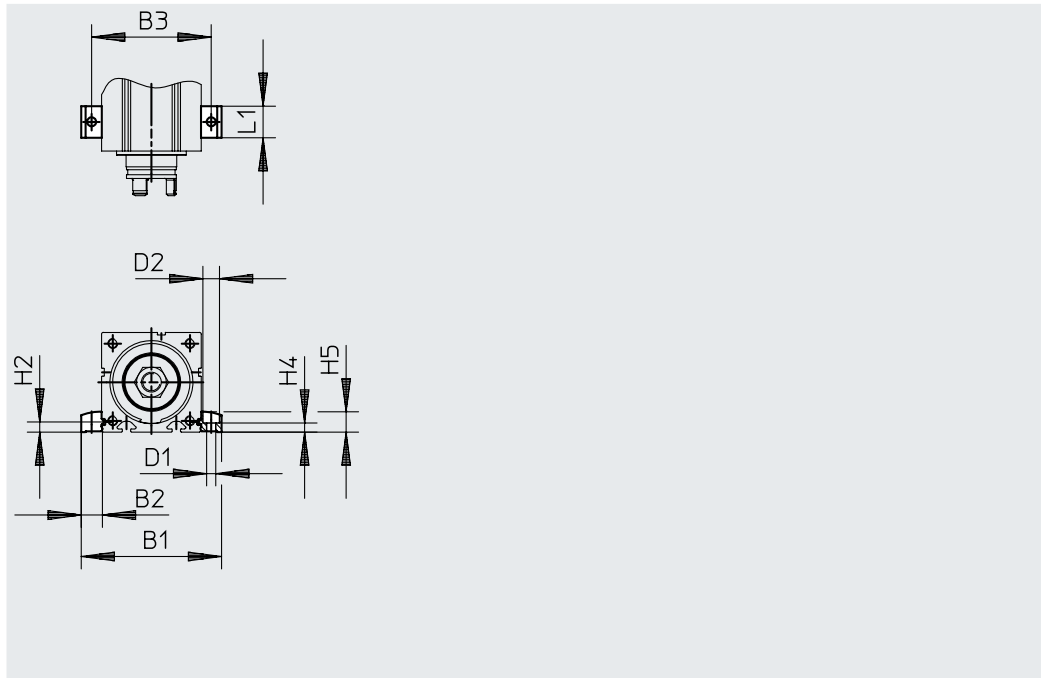
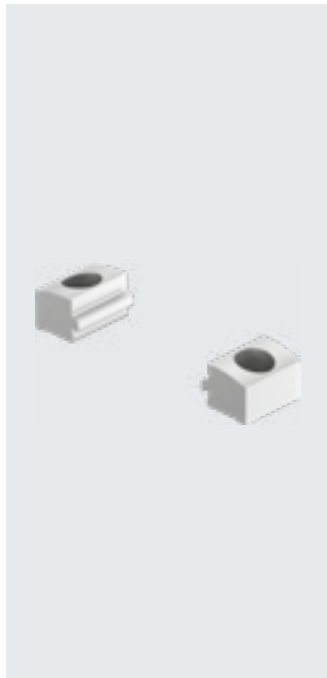

Dimensions and ordering data

For size	B1	B2	B3	D1 ∅ H13	D2 ∅ H13	H2
32	51.4	9.7	42	4.5	8	4.9
45	70.6	12.8	58	5.5	10	6.1
60	85.6	12.8	73	5.5	10	6.1

For size	H4 ±0.1	H5	L1	Weight [g]	Part no.	Type
32	4.2	9	19	4	5183153	EAHF-L2-25-P-S
45	5.5	12.2	19	6	5184133	EAHF-L2-45-P-S
60	5.5	12.2	19	6	5184133	EAHF-L2-45-P-S

Accessories

Profile mounting EAHF-L2-...-P

Material:

Anodised wrought aluminium alloy

RoHS-compliant

- For mounting the cylinder on the side of the profile.

The profile mounting can be attached to the mounting surface using the drilled hole in the centre

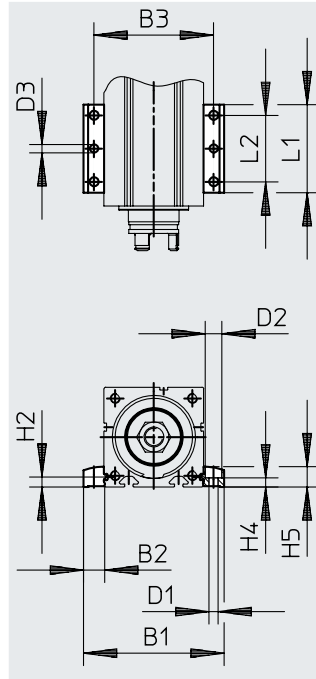

Dimensions and ordering data

For size	B1	B2	B3	D1 ∅ H13	D2 ∅ H13	D3 ∅	H2
32	51.4	9.7	42	4.5	8	4	4.9
45	70.6	12.8	58	5.5	10	5	6.1
60	85.6	12.8	73	5.5	10	5	6.1

For size	H4 ±0.1	H5	L1	L2	Weight [g]	Part no.	Type
32	4.2	9	53	40	19	4835684	EAHF-L2-25-P
45	5.5	12.2	53	40	35	4835728	EAHF-L2-45-P
60	5.5	12.2	53	40	35	4835728	EAHF-L2-45-P

Accessories

Flange mounting EAHH

Material:
Galvanised steel
RoHS-compliant

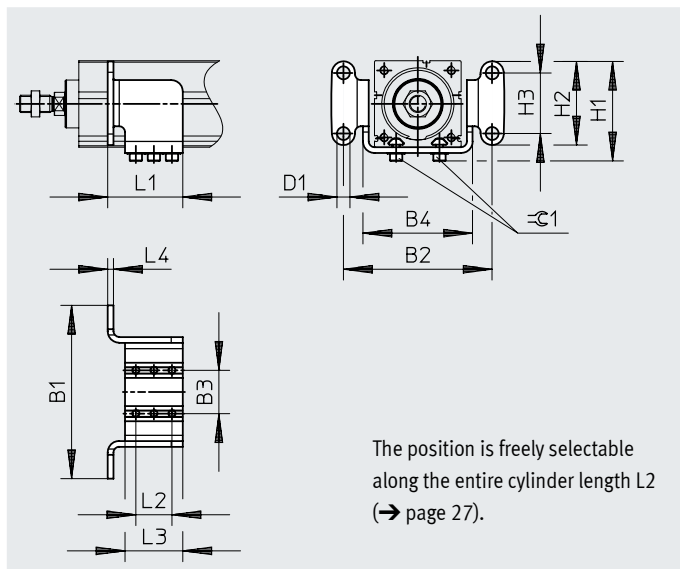
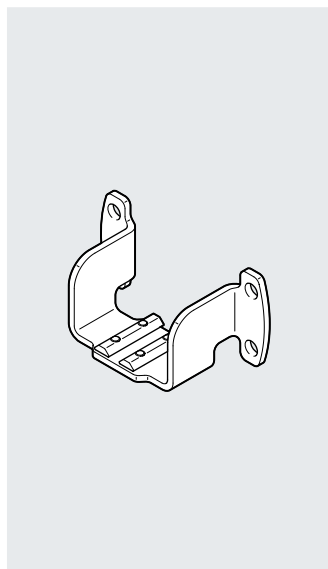

Dimensions and ordering data

For size	B1	B2	B3 ±0.1	B4	D1 ∅	H1	H2	H3	L1
32	70	58	16	42	5.5	39	31	20	38
45	100	85	24	61	6.6	54.5	48	35	42
60	120	103	30	76	9	69	58	42	52

For size	L2	L3	L4	≅G1	CRC ¹⁾	Weight [g]	Part no.	Type
32	20	30	2.5	2.5	1	80	5126157	EAHH-P2-32
45	20	30	4	2.5	1	185	5126669	EAHH-P2-45
60	25	40	4	4	1	320	5127005	EAHH-P2-60

1) Corrosion resistance class CRC 1 to Festo standard FN 940070

Low corrosion stress. Dry internal application or transport and storage protection. Also applies to parts behind covers, in the non-visible interior area, or parts that are covered in the application (e.g. drive trunnions).

Accessories

Adapter kit EAHA

Material:
Galvanised steel

RoHS-compliant

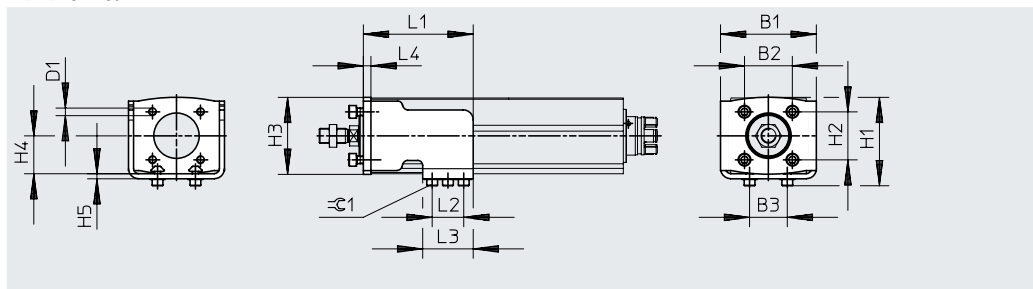
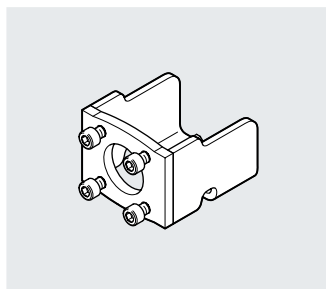

Dimensions and ordering data

For size	B1	B2	B3	D1	H1	H2	H3	H4	H5
		±0.2	±0.1			±0.2			
32	53	22	16	M5	42	22	37	18	2.5
45	61	32.5	24	M6	54	32.5	49	22.5	4
60	76	38	30	M6	69.5	38	61	30	4

For size	L1	L2	L3	L4	≅G1	CRC ¹⁾	Weight [g]	Part no.	Type
32	64	20	30	4	2.5	1	165	5173020	EAHA-P2-32
45	68	20	30	6	2.5	1	340	5172353	EAHA-P2-45
60	87	25	40	6	4	1	560	5173082	EAHA-P2-60

1) Corrosion resistance class CRC 1 to Festo standard FN 940070

Low corrosion stress. Dry internal application or transport and storage protection. Also applies to parts behind covers, in the non-visible interior area, or parts that are covered in the application (e.g. drive trunnions).

Accessories

Swivel mounting EAHS

Material:
Galvanised steel
RoHS-compliant

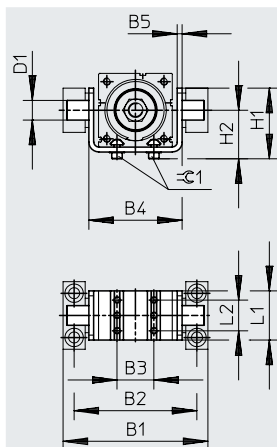
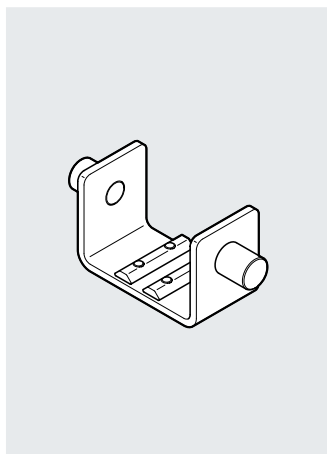

The position is freely selectable along the entire cylinder length L2 (→ page 27).

Dimensions and ordering data

For size	B1	B2	B3 ±0.1	B4	B5	D1 ∅ e9	H1
32	68	57	16	42	2.5	8	32
45	98	83	24	62	4	12	44.5
60	118	100	30	76	4	16	57

For size	H2	L1	L2	=G1	CRC ¹⁾	Weight [g]	Part no.	Type
32	23.5	30	20	2.5	1	75	5125041	EAHS-P2-32
45	29.5	30	20	2.5	1	165	5125167	EAHS-P2-45
60	39	40	25	4	1	305	5125281	EAHS-P2-60

1) Corrosion resistance class CRC 1 to Festo standard FN 940070

Low corrosion stress. Dry internal application or transport and storage protection. Also applies to parts behind covers, in the non-visible interior area, or parts that are covered in the application (e.g. drive trunnions).

Trunnion support LNZG

Material:
Trunnion support: Anodised aluminium
Plain bearing: Plastic
Free of copper and PTFE
RoHS-compliant

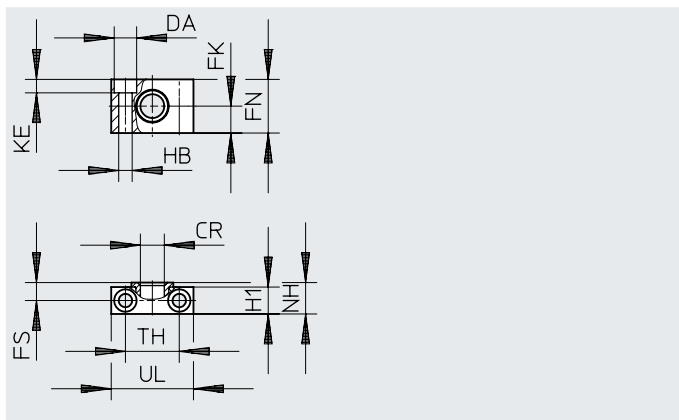

Dimensions and ordering data

For size	CR ∅ D11	DA ∅ H13	FK ∅ ±0.1	FN	FS	H1	HB ∅ H13	KE	NH	TH ±0.2	UL	CRC ¹⁾	Weight [g]	Part no.	Type
32	8	8	10	20	7.5	11	4.5	4.6	13	20	30	2	26	1434912	LNZG-16
45	12	11	15	30	10.5	15	6.6	6.8	18	32	46	2	83	32959	LNZG-32
60	16	15	18	36	12	18	9	9	21	36	55	2	129	32960	LNZG-4 0/50

1) Corrosion resistance class CRC 2 to Festo standard FN 940070

Moderate corrosion stress. Indoor applications in which condensation can occur. External visible parts with primarily decorative surface requirements that are in direct contact with a normal industrial environment.

Accessories

Swivel flange SNCS

Material:

Die-cast aluminium

Free of copper and PTFE

RoHS-compliant

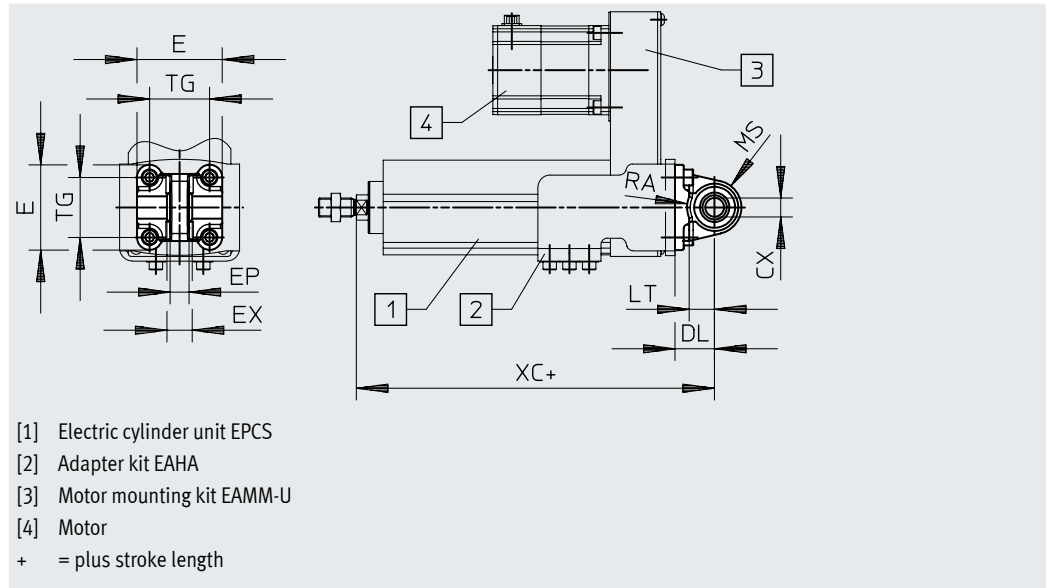

Dimensions and ordering data

For size	CX	DL	E	L	EP	EX	LT
		±0.2			±0.2		
45	10 ^{+0.13}	22	45 ^{+0.2/-0.5}	3	10.5	14	13
60	12 ^{+0.15}	25	54 ^{-0.5}	3	12	16	16

For size	MS	RA	TG	XC	CRC ¹⁾	Weight	Part no.	Type
						[g]		
45	15	14.5	32.5	154.9	1	86	174397	SNCS-32
60	17	17.5	38	182	1	122	174398	SNCS-40

1) Corrosion resistance class CRC 1 to Festo standard FN 940070

Low corrosion stress. Dry internal application or transport and storage protection. Also applies to parts behind covers, in the non-visible interior area, or parts that are covered in the application (e.g. drive trunnions).

Accessories

Swivel flange SNCL

Material:
Wrought aluminium alloy

Free of copper and PTFE
RoHS-compliant

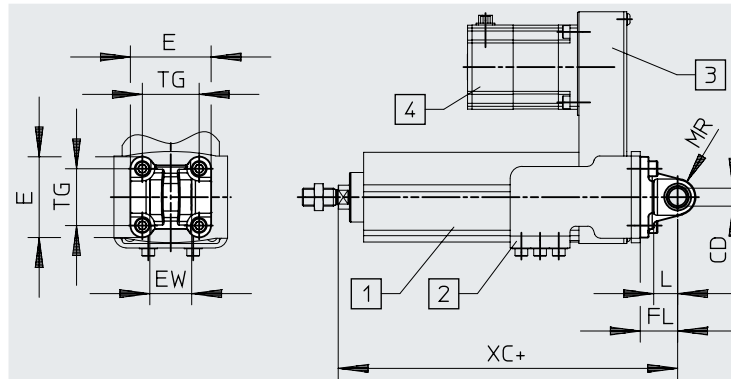
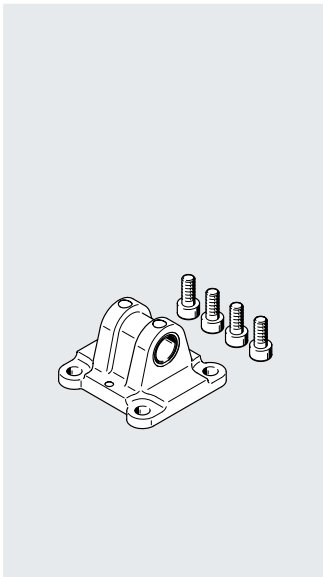

- [1] Electric cylinder unit EPCS
- [2] Adapter kit EAHA
- [3] Motor mounting kit EAMM-U
- [4] Motor
- + = plus stroke length

Dimensions and ordering data

For size	CD ∅ H10	E	EW h12	FL ±0.2	L	LT
25	6	27.5 _{-0.6}	12 _{h12}	16	3	10
32	8	34.5 _{-0.6}	16 _{h12}	20	3	14
45	10	45 _{+0.2/-0.5}	26 _{-0.2/-0.6}	22	3	13
60	12	54 _{-0.5}	28 _{-0.2/-0.6}	25	3	16

For size	MR	TG	XC	CRC ¹⁾	Weight [g]	Part no.	Type
25	6	18	115.7	2	21	537791	SNCL-16
32	8	22	133.9	2	38	537792	SNCL-20
45	10	32.5	154.9	1	71	174404	SNCL-32
60	12	38	182	1	95	174405	SNCL-40

1) Corrosion resistance class CRC 1 to Festo standard FN 940070

Low corrosion stress. Dry internal application or transport and storage protection. Also applies to parts behind covers, in the non-visible interior area, or parts that are covered in the application (e.g. drive trunnions).

Corrosion resistance class CRC 2 to Festo standard FN 940070

Moderate corrosion stress. Indoor applications in which condensation can occur. External visible parts with primarily decorative surface requirements that are in direct contact with a normal industrial environment.

Accessories

Swivel flange SNCB

Material:

Die-cast aluminium

Free of copper and PTFE

RoHS-compliant

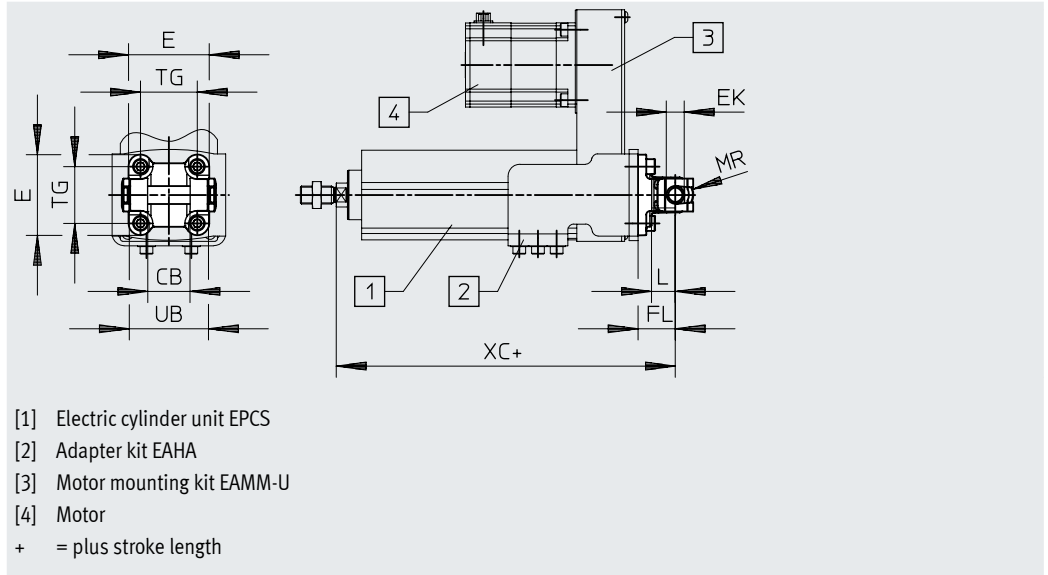
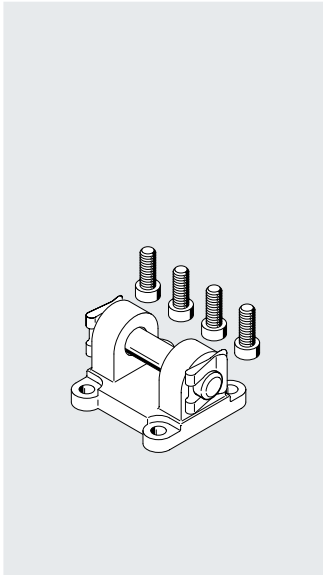

- [1] Electric cylinder unit EPCS
- [2] Adapter kit EAHA
- [3] Motor mounting kit EAMM-U
- [4] Motor
- + = plus stroke length

Dimensions and ordering data

For size	CB	E	EK ∅	FL	L	LT	MR
	H14		H10/e8	±0.2			-0.5
45	26	45+0.2/-0.5	10	22	3	13	8.5
60	28	54-0.5	12	25	3	16	12

For size	TG	UB	XC	CRC ¹⁾	Weight [g]	Part no.	Type
		h14					
45	32.5	45	154.9	1	103	174390	SNCB-32
60	38	52	182	1	155	174391	SNCB-40

1) Corrosion resistance class CRC 1 to Festo standard FN 940070

Low corrosion stress. Dry internal application or transport and storage protection. Also applies to parts behind covers, in the non-visible interior area, or parts that are covered in the application (e.g. drive trunnions).

Accessories

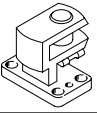
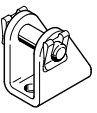

Ordering data – Mounting components

Designation	For size	Part no.	Type
Right angle clevis foot LQG			
	45	31768	LQG-32
	60	31769	LQG-40
Clevis foot LBN			
	32	6059	LBN-2 0/25

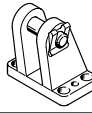

Datasheets → Internet: clevis foot

Designation	For size	Part no.	Type
Clevis foot LBG			
	45	31761	LBG-32
	60	31762	LBG-40

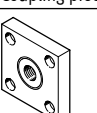
Ordering data – Piston rod attachments

Designation	For size	Part no.	Type
Rod eye SGS			
	32	9255	SGS-M8
	45	9261	SGS-M10x1.25
	60	9262	SGS-M12x1.25
Self-aligning rod coupler FK			
	32	2062	FK-M8
	45	6140	FK-M10x1.25
	60	6141	FK-M12x1.25
Coupling piece KSG			
	45	32963	KSG-M10x1.25
	60	32964	KSG-M12x1.25

Datasheets → Internet: piston rod attachment

Designation	For size	Part no.	Type
Rod clevis SG			
	32	3111	SG-M8
	45	6144	SG-M10x1.25
	60	6145	SG-M12x1.25
Rod clevis SGA			
	45	32954	SGA-M10x1.25
	60	10767	SGA-M12x1.25

Ordering data – Push-in fitting for sealing air connection

	For size	Part no.	Type	PU ¹⁾
	32	133003	QSM-M5-3-I-R	10
		133004	QSM-M5-4-I-R	
	45	186266	QSM-G1/8-4-I	
		186267	QSM-G1/8-6-I	
	60	186108	QS-G1/4-6-I	
		186110	QS-G1/4-8-I	

1) Packaging unit

Ordering data – Slot nut

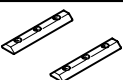
	For size	Description	Part no.	Type	PU ¹⁾
	32, 45	For mounting the electric cylinder unit	8169987	ABAN-3-3M3-30-M-P2	2
	60		8169988	ABAN-5-3M5-40-M-P2	

1) Packaging unit

Accessories

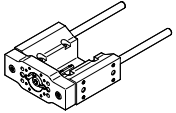
Ordering data – Guide units		Datasheets → Internet: eagf	
Stroke [mm]	Part no.	Type	
	For size 32		
	50	8158032	EAGF-P2-KF-32-50
	100	8158029	EAGF-P2-KF-32-100
	150	8158027	EAGF-P2-KF-32-150
	200	8158028	EAGF-P2-KF-32-200
	25, 75, 125, 175	8158030	EAGF-P2-KF-32-
	For size 45		
	50	8158131	EAGF-P2-KF-45-50
	100	8158123	EAGF-P2-KF-45-100
	150	8158125	EAGF-P2-KF-45-150
	200	8158127	EAGF-P2-KF-45-200
	300	8158130	EAGF-P2-KF-45-300
	25, 75, 125, 175, 250	8158133	EAGF-P2-KF-45-
	For size 60		
	100	8158138	EAGF-P2-KF-60-100
	150	8158140	EAGF-P2-KF-60-150
200	8158142	EAGF-P2-KF-60-200	
300	8158031	EAGF-P2-KF-60-300	
25, 50, 75, 125, 175, 250, 350, 400, 500	8158150	EAGF-P2-KF-60-	

Accessories

Sensor bracket EAPM-L2

Material:
Anodised wrought aluminium alloy
RoHS-compliant

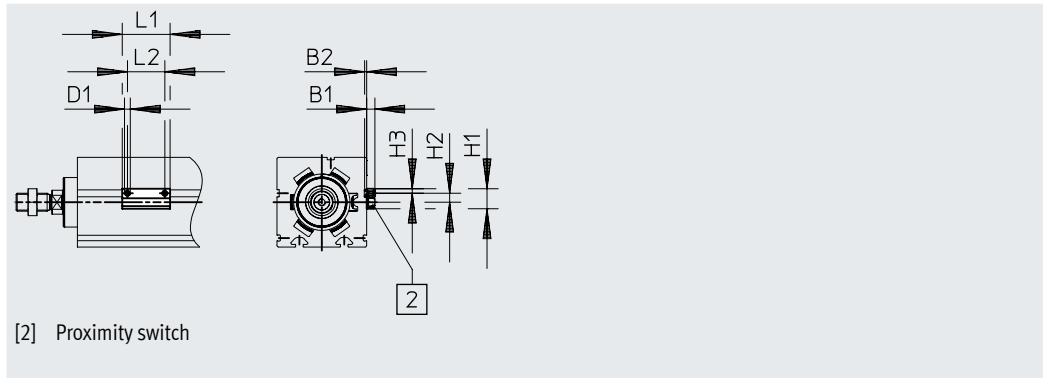

Dimensions and ordering data						
For size	B1	B2	D1	H1	H2	
32, 45, 60	5.5	1.3	M4	13.4	6	

For size	H3	L1	L2	Weight [g]	Part no.	Type
32, 45, 60	3	32	25	4	4759852	EAPM-L2-SH

Ordering data – Proximity switch for T-slot, magneto-resistive							Datasheets → Internet: smt
	Type of mounting	Switching output	Electrical connection	Cable length [m]	Part no.	Type	
N/O							
	Inserted in the slot from above, flush with the cylinder profile, short design	PNP	Cable, 3-core	2.5	574335	SMT-8M-A-PS-24V-E-2.5-OE	
			Plug M8x1, 3-pin	0.3	574334	SMT-8M-A-PS-24V-E-0.3-M8D	
		NPN	Cable, 3-core	2.5	574338	SMT-8M-A-NS-24V-E-2.5-OE	
			Plug M8x1, 3-pin	0.3	574339	SMT-8M-A-NS-24V-E-0.3-M8D	
N/C							
	Inserted in the slot from above, flush with the cylinder profile, short design	PNP	Cable, 3-core	7.5	574340	SMT-8M-A-PO-24V-E-7.5-OE	
				2.5	8138000	SMT-8M-A-NO-24V-E-2.5-OE	
		NPN		7.5	8138001	SMT-8M-A-NO-24V-E-7.5-OE	

Ordering data – Connecting cables							Datasheets → Internet: nebu
	Electrical connection, left	Electrical connection, right	Cable length [m]	Part no.	Type		
	Straight socket, M8x1, 3-pin	Cable, open end, 3-core	2.5	541333	NEBU-M8G3-K-2.5-LE3		
			5	541334	NEBU-M8G3-K-5-LE3		
	Angled socket, M8x1, 3-pin	Cable, open end, 3-core	2.5	541338	NEBU-M8W3-K-2.5-LE3		
			5	541341	NEBU-M8W3-K-5-LE3		

Accessories

Ordering data – IO-Link master USB					Datasheets → Internet: cdsu
	Description	Cable length [m]	Part no.	Type	
	<ul style="list-style-type: none"> For using the unit with IO-Link® An external power supply plug is also required (not included in the scope of delivery) 	0.3	8091509	CDSU-1	

Ordering data – Adapter					Datasheets → Internet: nefc
	Electrical connection, left	Electrical connection, right	Cable length [m]	Part no.	Type
	Straight socket, M12x1, 8-pin	<ul style="list-style-type: none"> Straight plug M12x1, 5-pin Only recommended for use with IO-Link® port class A master 	0.3	8080777	NEFC-M12G8-0.3-M12G5-LK

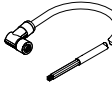
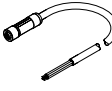
Ordering data – Supply cables					Datasheets → Internet: nebl
	Electrical connection, left	Electrical connection, right	Cable length [m]	Part no.	Type
	Angled socket, M12x1, 4-pin	Cable, open end, 4-core	2	8080778	NEBL-T12W4-E-2-N-LE4
			5	8080779	NEBL-T12W4-E-5-N-LE4
			10	8080780	NEBL-T12W4-E-10-N-LE4
			15	8080781	NEBL-T12W4-E-15-N-LE4
	Straight socket, M12x1, 4-pin	Cable, open end, 4-core	2	8080790	NEBL-T12G4-E-2-N-LE4
			5	8080791	NEBL-T12G4-E-5-N-LE4
			10	8080792	NEBL-T12G4-E-10-N-LE4
			15	8080793	NEBL-T12G4-E-15-N-LE4

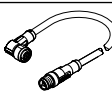
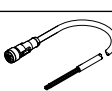
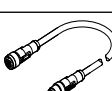
Ordering data – Connecting cables					Datasheets → Internet: nebc
	Electrical connection, left	Electrical connection, right	Cable length [m]	Part no.	Type
	Angled socket, M12x1, 8-pin	Cable, open end, 8-core	2	8094476	NEBC-M12W8-E-2-N-B-LE8
			5	8094478	NEBC-M12W8-E-5-N-B-LE8
			10	8094481	NEBC-M12W8-E-10-N-B-LE8
			15	8094479	NEBC-M12W8-E-15-N-B-LE8
	Straight socket, M12x1, 8-pin	Straight plug, M12x1, 8-pin	2	8080786	NEBC-M12W8-E-2-N-M12G8
			5	8080787	NEBC-M12W8-E-5-N-M12G8
			10	8080788	NEBC-M12W8-E-10-N-M12G8
			15	8080789	NEBC-M12W8-E-15-N-M12G8
	Straight socket, M12x1, 8-pin	Cable, open end, 8-core	2	8094480	NEBC-M12G8-E-2-N-B-LE8
			5	8094477	NEBC-M12G8-E-5-N-B-LE8
			10	8094482	NEBC-M12G8-E-10-N-B-LE8
			15	8094475	NEBC-M12G8-E-15-N-B-LE8
	Straight socket, M12x1, 8-pin	Straight plug, M12x1, 8-pin	2	8080782	NEBC-M12G8-E-2-N-M12G8
			5	8080783	NEBC-M12G8-E-5-N-M12G8
			10	8080784	NEBC-M12G8-E-10-N-M12G8
			15	8080785	NEBC-M12G8-E-15-N-M12G8

 **Note**
The cables are positioned at a 45° angle to the axis.

