

Electric cylinders EPCC, with spindle drive

FESTO

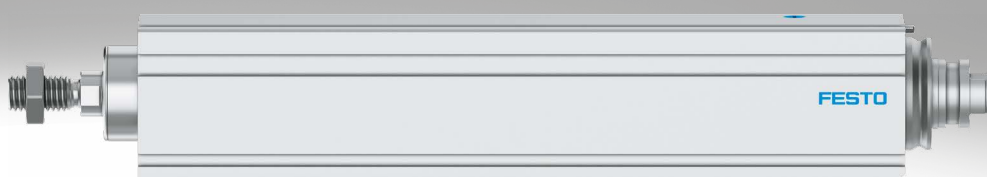

Key features

At a glance

General

The electric cylinder EPCC is a mechanical linear drive with piston rod. The drive component consists of an electrically actuated spindle that converts the rotary motion of the motor into linear motion of the piston rod.

Suitable for simple applications in factory automation that in the past were mostly carried out using pneumatic solutions.

Characteristics

- With ball screw
- Degree of protection IP40
- External or internal thread on the piston rod
- Compact dimensions
- Extensive mounting accessories for various installation situations
- Dirt wiper: the piston rod is equipped with a single standard wiper that removes lightly adhering particles

Complete system consisting of electric cylinder, motor and motor mounting kit

Electric cylinder

→ Page 3



Motor

→ Page 18



Motor mounting kit

→ Page 18

Axial kit

Parallel kit

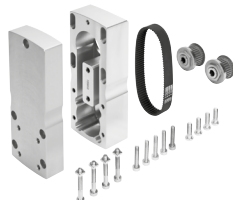
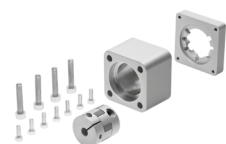

Complete kits are available for both parallel and axial motor mounting.

Servo drive/motor controller



Type codes

001	Series
EPCC	Electric cylinder

002	Drive system
BS	Ball screw drive

003	Size
25	25
32	32
45	45
60	60

004	Stroke [mm]
25	25
50	50
75	75
100	100
125	125
150	150
175	175
200	200
250	250
300	300
350	350
400	400
500	500

005	Spindle pitch
2P	2 mm
3P	3 mm
5P	5 mm
6P	6 mm
8P	8 mm
10P	10 mm
12P	12 mm

006	Piston rod thread type
	Male thread
F	Female thread

007	Scraper variant
	None
A7	Wiper

008	Piston rod extension
	None
...E	1 ... 100 mm

009	Position sensing
A	For proximity sensor

010	Guide unit
	None
KF	Recirculating ball bearing with two guide rods

Peripherals overview

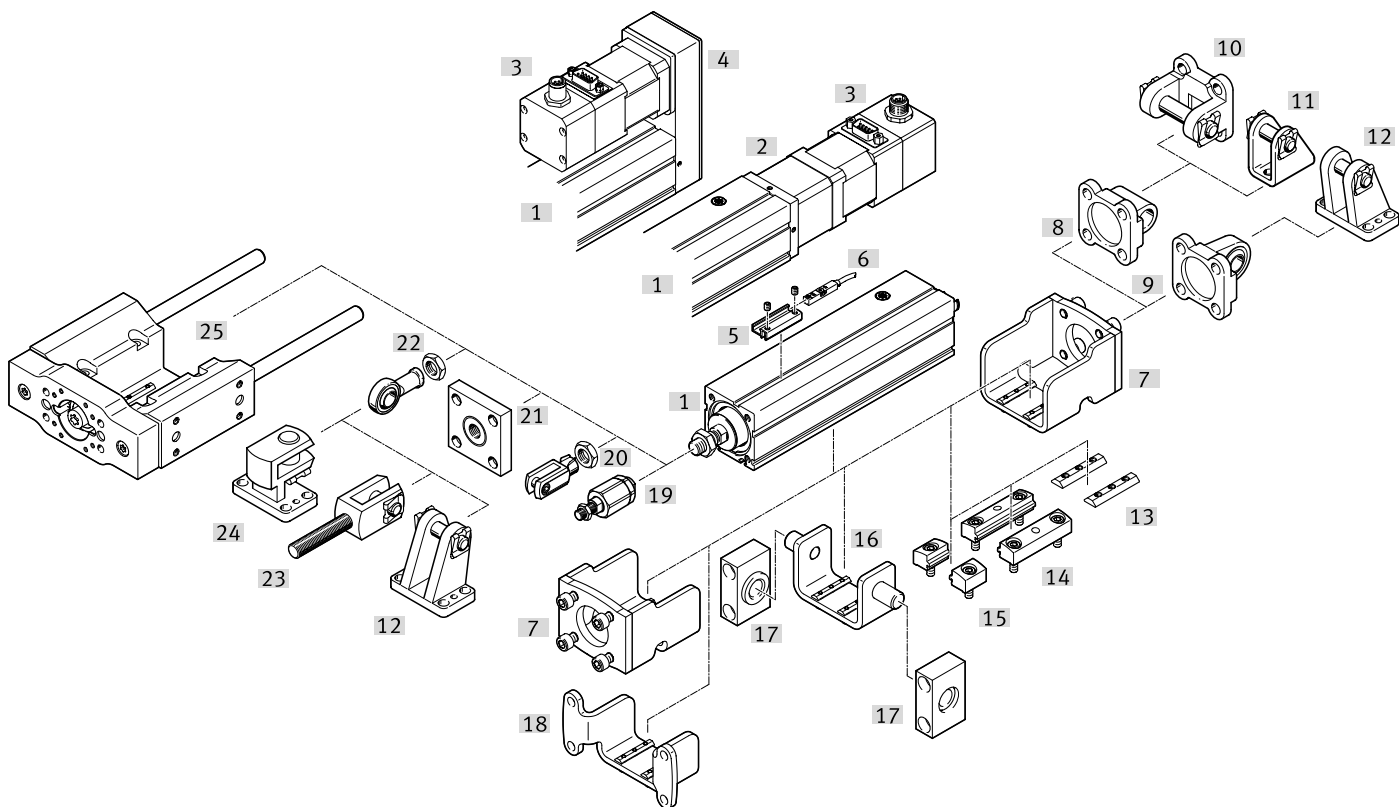

Sealing air connection

Air is exchanged between the interior of the cylinder and the environment via a sealing air connection. This prevents negative pressure or overpressure from building up inside the cylinder.

Additional functions of the connection:



- Application of slight negative pressure prevents the emission of particles
- Application of slight overpressure prevents the ingress of particles

Peripherals overview

Mounting attachments and accessories		Description	For size				→ Page/ Internet
			25	32	45	60	
[1]	Electric cylinder EPCC	Electric drive	■	■	■	■	6
[2]	Axial kit EAMM-A	For axial motor mounting	■	■	■	■	18
[3]	Motor EMMT-AS; EMME-AS; ...	Motors specially adapted to the electric cylinder	■	■	■	■	18
[4]	Parallel kit EAMM-U	For parallel motor mounting	■	■	■	■	19
[5]	Sensor bracket EAPM-L2	For mounting the proximity sensors on the electric cylinder. The proximity switches can only be mounted using the sensor bracket	■	■	■	■	30
[6]	Proximity switch SMT-8M	Magnetic proximity switches, for T-slot	■	■	■	■	30
[7]	Adapter kit EAHA-P2	<ul style="list-style-type: none"> For mounting the swivel flange and trunnion flange on the front Can only be mounted on the rear in conjunction with parallel kit EAMM-U 	■	■	■	■	23
[8]	Swivel flange SNCL	With parallel motor mounting	■	■	■	■	26
[9]	Swivel flange SNCS/CRSNCS/SNCS-...-R3	With parallel motor mounting	-	-	■	■	25
[10]	Swivel flange SNCB	With parallel motor mounting, for spherical bearing	-	-	■	■	27
[11]	Clevis foot LBN	With parallel motor mounting, for spherical bearing	■	■	-	-	28
[12]	Clevis foot LBG/LBG-...-R3	With parallel motor mounting, for spherical bearing	-	-	■	■	28
[13]	Slot nut ABAN	For mounting the electric cylinder	■	■	■	■	28
[14]	Profile mounting EAHF-L2-P	<ul style="list-style-type: none"> For mounting the electric cylinder laterally on the profile The profile mounting can be attached to the mounting surface using the drilled hole in the centre 	■	■	■	■	21
[15]	Profile mounting EAHF-L2-P-S	For mounting the electric cylinder laterally on the profile	■	■	■	■	20
[16]	Swivel mounting EAHS-P2	Position freely selectable along the cylinder length	■	■	■	■	24
[17]	Trunnion support LNZG	For cylinders with trunnion flange mounting	■	■	■	■	24
[18]	Flange mounting EAHH-P2	<ul style="list-style-type: none"> For mounting the electric cylinder via the profile Position freely selectable along the cylinder length 	■	■	■	■	22
[19]	Self-aligning rod coupler FK/CRFK	To compensate for radial and angular deviations	■	■	■	■	28
[20]	Rod clevis SG/CRSG	Permits a swivelling motion of the electric cylinder in one plane	■	■	■	■	28
[21]	Coupling piece KSG	To compensate for radial deviations	-	-	■	■	28
[22]	Rod eye SGS/CRSGS	With spherical bearing	■	■	■	■	28
[23]	Rod clevis SGA	For swivel mounting of the cylinder	-	-	■	■	28
[24]	Right angle clevis foot LQG	For rod eye SGS	-	-	■	■	28
[25]	Guide unit EAGF	For protecting electric cylinders against rotation at high torque loads	-	■	■	■	29

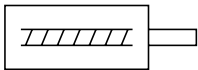
Datasheet



-  Size
25 ... 60
-  Stroke length
25 ... 500 mm



General technical data

Size	25	32	45	60
Design	Electric cylinder with ball screw			
Piston rod thread				
Male thread	M6	M8	M10x1.25	M12x1.25
Female thread	M4	M6	M8	M10
Working stroke [mm]	25 ... 200	25 ... 200	25 ... 300	25 ... 500
Stroke reserve [mm]	0			
Protection against rotation/guide	With plain-bearing guide			
Max. angle of rotation of the piston rod [°]	≤ ±1			
Position sensing	Via proximity switch			
Type of mounting	-		Via female thread	
	Via accessories			
Mounting position	Any			

Mechanical data

Size	25		32		45		60	
Spindle design	2P	6P	3P	8P	3P	10P	5P	12P
Spindle pitch [mm/rev]	2	6	3	8	3	10	5	12
Spindle diameter [mm]	6	6	8	8	10	10	12	12
Max. payload								
Horizontal [kg]	12	12	24	24	60	60	120	120
Vertical [kg]	6	6	12	12	30	30	60	60
Max. feed force F_x [N]	75	75	150	150	450	450	1000	1000
Max. radial force ¹⁾ [N]	30	30	75	75	180	180	230	230
Max. driving torque [Nm]	0.05	0.1	0.15	0.3	0.4	0.9	1.2	2.4
No-load driving torque ²⁾ [Nm]	0.02	0.055	0.065	0.095	0.08	0.16	0.235	0.325
Max. speed ³⁾ [m/s]	0.133	0.4	0.188	0.5	0.18	0.6	0.25	0.6
Max. acceleration [m/s ²]	5	15	5	15	5	15	5	15
Max. rotational speed [rpm]	4000	4000	3750	3750	3600	3600	3000	3000
Reversing backlash ⁴⁾ [mm]	≤ 0.1							
Repetition accuracy [mm]	±0.02							

- 1) At the drive shaft
- 2) Corresponds to the required driving torque without load, at a spindle speed of 200 rpm.
- 3) The speed is stroke-dependent → Page 9
- 4) When new.

Operating and environmental conditions

Ambient temperature ¹⁾ [°C]	0 ... +60
Storage temperature [°C]	-20 ... +60
Relative humidity [%]	0 ... 95 (non-condensing)
Degree of protection to IEC 60529	IP40
Duty cycle [%]	100
Maintenance interval	Lifetime lubrication

- 1) Note operating range of proximity switches

Datasheet

Weight [g]				
Size	25	32	45	60
Basic weight with 0 mm stroke				
EPCC-...	132	225	555	1114
EPCC-...-KF	-	838	1592	2728
Additional weight per 10 mm stroke				
EPCC-...	13	24	41	69
EPCC-...-KF	-	32	53	87
Moving mass with 0 mm stroke				
EPCC-...	53	98	179	305
EPCC-...-KF	-	268	521	888
Moving mass per 10 mm stroke				
EPCC-...	2.6	3.3	4.9	6.5
EPCC-...-KF	-	11.2	17.2	24.3

Mass moments of inertia									
Size	25		32		45		60		
	2P	6P	3P	8P	3P	10P	5P	12P	
J_0 with 0 mm stroke	[kg mm ²]	0.09	0.14	0.42	0.55	1.09	1.53	6.82	7.79
j_S per metre stroke	[kg mm ² /m]	0.56	0.95	2.56	3.11	5.03	7.11	11.95	15.19
j_L per kg payload	[kg mm ² /kg]	0.1	0.91	0.23	1.62	0.23	2.53	0.63	3.65

The mass moment of inertia J_A of the electric cylinder is calculated as follows:

$$J_A = J_0 + j_S \times \text{working stroke [m]} + j_L \times m_{\text{moving payload [kg]}}$$

Homing

Homing can be carried out in two ways:

- Against a fixed stop
- Using a reference switch

The following values must be observed:

Size	25	32	45	60
Max. impact energy [J]	0.0012	0.0036	0.012	0.024
Max. homing speed [m/s]	0.01			

Materials

Sectional view

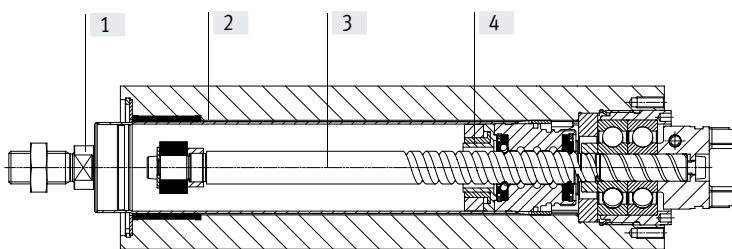

Electric cylinder	
[1] Piston rod	High-alloy stainless steel
[2] Housing	Smooth-anodised wrought aluminium alloy
[3] Spindle	Roller bearing steel
[4] Spindle nut	Steel
Note on materials	RoHS-compliant
LABS (PWIS) conformity	VDMA24364 zone III

Datasheet

Maximum permissible loads on the piston rod

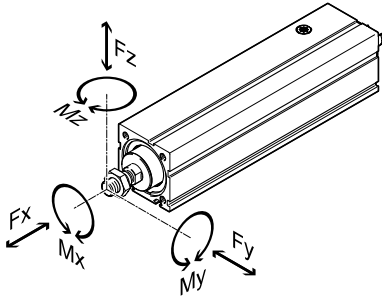

If there are two or more forces and torques simultaneously acting on the piston rod, the following equations must be satisfied:

$$F_1/M_1 = \text{dynamic value}$$

$$F_2/M_2 = \text{maximum value}$$

$$f_v = \frac{|F_{y1}|}{F_{y2}} + \frac{|F_{z1}|}{F_{z2}} + \frac{|M_{y1}|}{M_{y2}} + \frac{|M_{z1}|}{M_{z2}} \leq 1$$

$$|Fx| \leq Fx_{max}$$

$$|Mx| \leq Mx_{max}$$

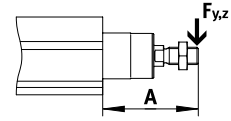

Maximum permissible lateral forces $F_{y_{max}}$ and $F_{z_{max}}$ on the piston rod as a function of projection A

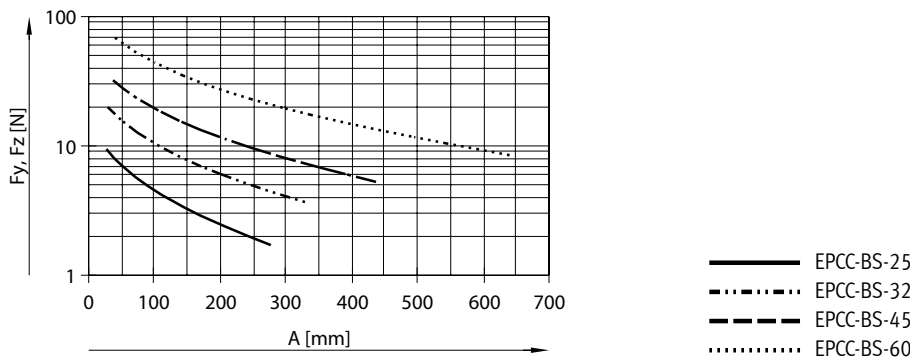

Size	25		32		45		60	
Spindle design	2P	6P	3P	8P	3P	10P	5P	12P
$F_{x_{max}}$ (static) [N]	75	75	150	150	450	450	1000	1000
$M_{x_{max}}$ [Nm]	0							
$M_{y_{max}}, M_{z_{max}}$ [Nm]	0.6		1.5		2.9		6.4	

Note
 Engineering software
 Electric Motion Sizing
 → www.festo.com/x/electric-motion-sizing

Datasheet

Piston rod deflection f_2 as a function of projection A and lateral force F

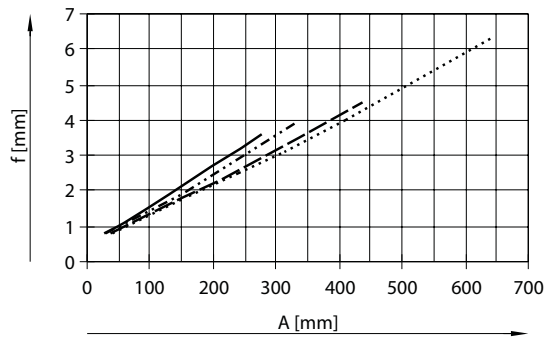
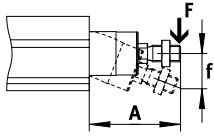

- EPCC-BS-25 ($F_2 = 1.5 \text{ N}$)
- ⋯ EPCC-BS-32 ($F_2 = 3.5 \text{ N}$)
- - - EPCC-BS-45 ($F_2 = 4.0 \text{ N}$)
- · - · EPCC-BS-60 ($F_2 = 8.0 \text{ N}$)

$$f_1 = \frac{F_1}{F_2} \cdot f_2$$

- f_1 = Piston rod deflection caused by lateral force [mm]
- F_1 = Lateral force [N]
- F_2 = Standardised lateral force [N] (constant force from graph)
- f_2 = Piston rod deflection caused by lateral force [N] (reading from graph)

Example: Electric cylinder EPCC-25-50-6P with a lateral force of 3 N
 $F_1 = 3 \text{ N}$ and $F_{\text{standard}} = 1.5 \text{ N}$

Value read from graph for EPCC-25 and projection = 50 mm
 $f_2 = 1 \text{ mm}$

Calculation of deflection caused by lateral force:

$$f_1 = \frac{F_1}{F_2} \cdot f_2 = \frac{3 \text{ N}}{1.5 \text{ N}} \cdot 1 \text{ mm} = 2 \text{ mm}$$

Feed speed v as a function of stroke length l

EPCC-BS-25-...

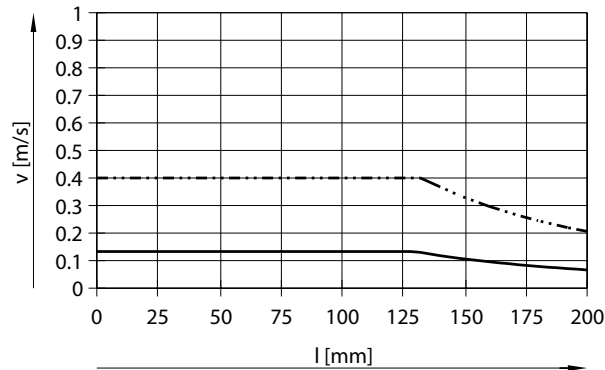

- EPCC-BS-25-2P
- ⋯ EPCC-BS-25-6P

EPCC-BS-32-...

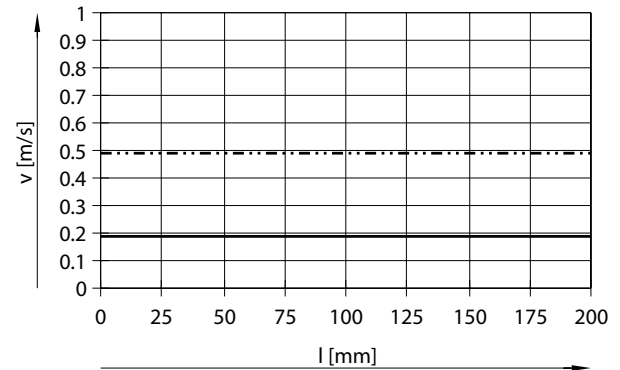

- EPCC-BS-32-3P
- ⋯ EPCC-BS-32-8P

EPCC-BS-45-...

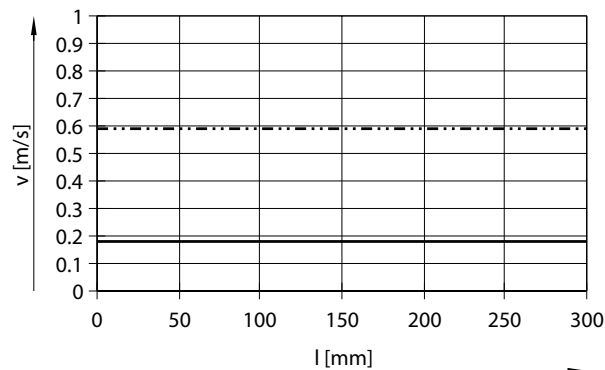

- EPCC-BS-45-3P
- ⋯ EPCC-BS-45-10P

EPCC-BS-60-...

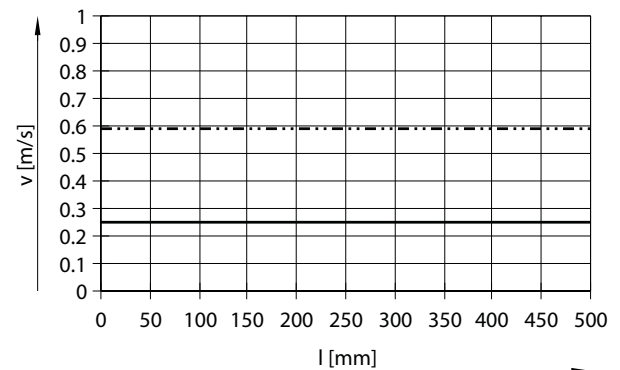

- EPCC-BS-60-5P
- ⋯ EPCC-BS-60-12P

Datasheet

Calculating the mean feed force F_{xm} with the electric cylinder EPCC

The peak feed force value must not exceed the maximum feed force within a movement cycle. The peak value is generally achieved in vertical operation during the acceleration phase of the upwards stroke. If the maximum feed force is exceeded, this can increase wear and thus shorten the service life of the ball screw. The maximum speed must also not be exceeded:

$$F_x \leq F_{x\max}$$

and

$$V_x \leq V_{x\max}$$

Calculating the mean feed force F_{xm} (to DIN 69051-4)

During operation, the continuous feed force may be briefly exceeded up to the maximum feed force. The continuous feed force must, however, be adhered to when averaged over a movement cycle:

$$F_{xm} \leq F_{x\text{continuous}}$$

$$F_{xm} = \sqrt[3]{\sum F_x^3 \cdot \frac{v_x}{v_{xm}} \cdot \frac{q}{100}} =$$

$$F_{xm} = \sqrt[3]{F_{x1}^3 \cdot \frac{v_{x1}}{v_{xm}} \cdot \frac{q_1}{100} + F_{x2}^3 \cdot \frac{v_{x2}}{v_{xm}} \cdot \frac{q_2}{100} + F_{x3}^3 \cdot \frac{v_{x3}}{v_{xm}} \cdot \frac{q_3}{100} + \dots}$$

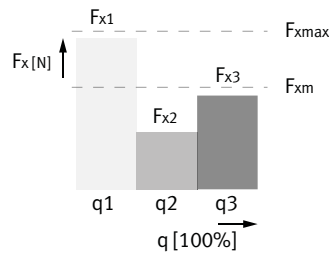

Mean feed speed (to DIN 69051-4)

$$v_{xm} = \sum v_x \cdot \frac{q}{100} = v_{x1} \cdot \frac{q_1}{100} + v_{x2} \cdot \frac{q_2}{100} + v_{x3} \cdot \frac{q_3}{100} + \dots$$

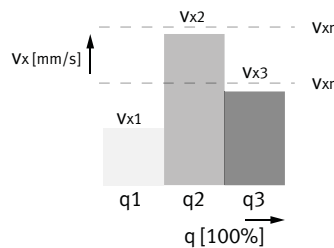

F_x	Feed force
F_{xm}	Mean feed force
$F_{x\max}$	Max. feed force
$F_{x\text{continuous}}$	Continuous feed force
q	Time
v_x	Feed speed
v_{xm}	Mean feed speed
$v_{x\max}$	Max. Feed speed

Datasheet

Mean feed force F_{xm} as a function of running performance L, with an operating coefficient f_B of 1.0 at room temperature

EPCC-BS-25-...

EPCC-BS-32-...

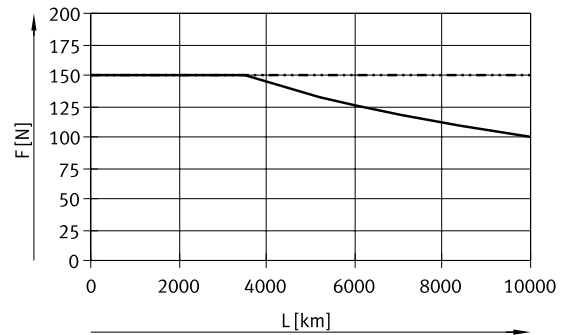
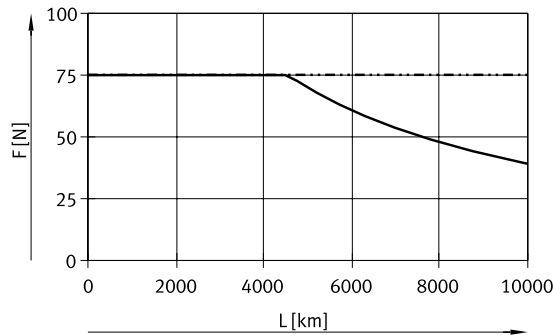

— EPCC-BS-25-2P
- · - · - EPCC-BS-25-6P

— EPCC-BS-32-3P
- · - · - EPCC-BS-32-8P

EPCC-BS-45-...

EPCC-BS-60-...

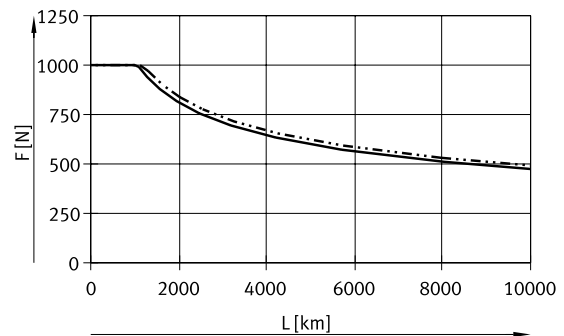
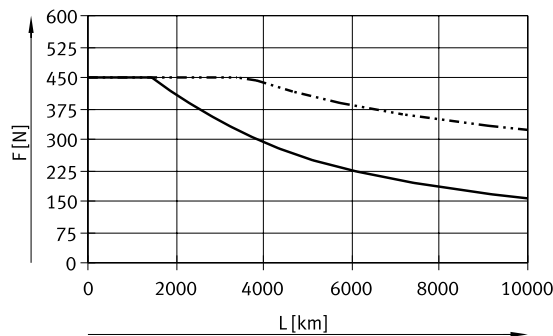

— EPCC-BS-45-3P
- · - · - EPCC-BS-45-10P

— EPCC-BS-60-5P
- · - · - EPCC-BS-60-12P

$$L_1 = \frac{L}{f_B^3}$$

L_1 Actual service life
L Target service life
(→ graphs)
 f_B Operating coefficient

Service life taking into account the operating coefficient

Load ¹⁾	Operating coefficient f_B	Sample application
None	1.0 ... 1.2	Measuring machine
Light	1.2 ... 1.4	Handling, robot technology
Medium	1.4 ... 1.6	Press-in operations
High	1.6 ... 2.0	Construction, agriculture

1) This refers to loads caused by impact, temperature, contamination, shock and vibrations that affect the cylinder or piston rod.

Note

The specifications for running performance are based on experimentally determined and theoretically calculated data (at room temperature). The running performance that can be achieved in practice can deviate considerably from the specified curves under different parameters.

Datasheet

Friction torque M_v as a function of feed speed v

EPCC-BS-25

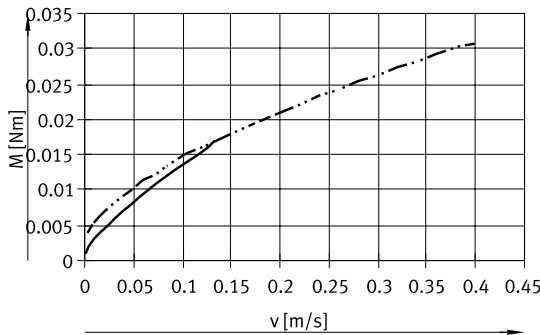

EPCC-BS-32

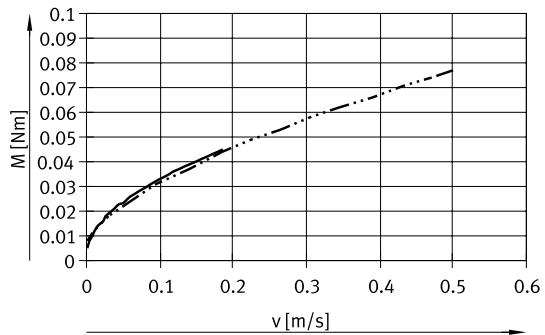

- EPCC-BS-25-2P
- - - EPCC-BS-25-6P

- EPCC-BS-32-3P
- - - EPCC-BS-32-8P

EPCC-BS-45

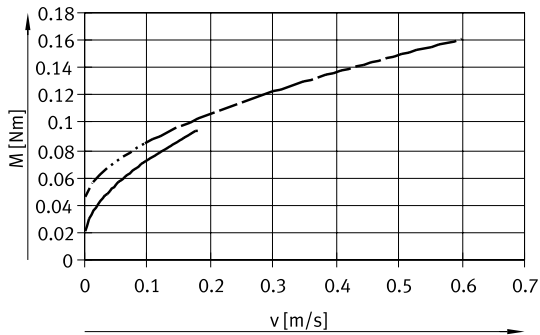

- EPCC-BS-45-3P
- - - EPCC-BS-45-10P

EPCC-BS-60

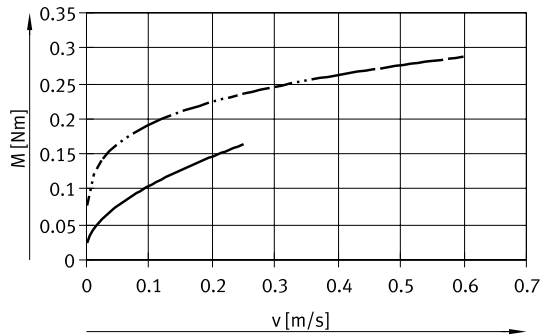

- EPCC-BS-60-5P
- - - EPCC-BS-60-12P

Friction losses and driving torque

Friction losses

The friction losses comprise the no-load driving torque and the speed-dependent friction losses.

$$M_{\text{friction}} = M_{\text{no-load}} + M_v$$

M_{friction} = Friction torque

$M_{\text{no-load}}$ = No-load driving torque

M_v = Friction torque as a function of feed speed

Driving torque

The driving torque required for the cylinder comprises the friction torque and the effective torque.

$$M_{\text{drive}} = M_{\text{friction}} + M_{\text{effective}}$$

M_{drive} = Required driving torque

M_{friction} = Friction torque

$M_{\text{effective}}$ = Effective torque

No-load driving torque¹⁾

Size	25		32		45		60	
Spindle pitch [mm/rev]	2	6	3	8	3	10	5	12
No-load driving torque $M_{\text{no-load}}$ [Nm]	0.02	0.055	0.065	0.095	0.08	0.16	0.235	0.325

1) Corresponds to the required driving torque without load, at a spindle rotational speed of 200 rpm.

Datasheet

Effective torque $M_{\text{effective}}$ as a function of feed force F

EPCC-BS-25-...

EPCC-BS-32-...

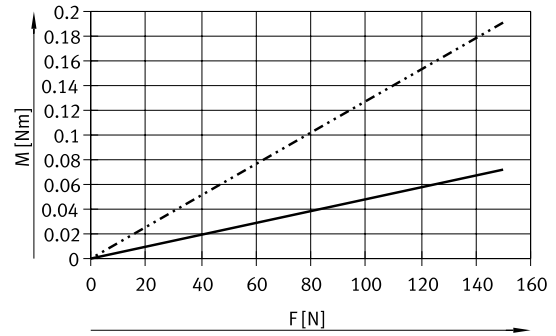
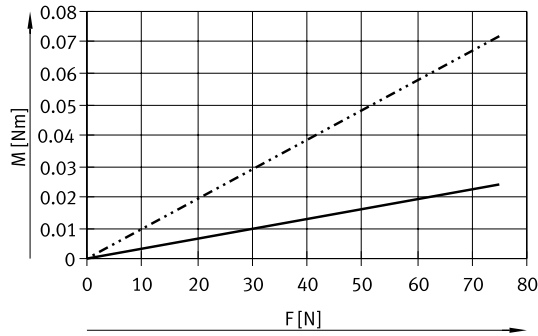

— EPCC-BS-25-2P
 - - - EPCC-BS-25-6P

— EPCC-BS-32-3P
 - - - EPCC-BS-32-8P

EPCC-BS-45-...

EPCC-BS-60-...

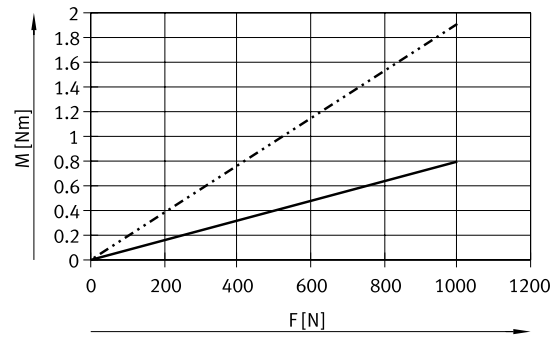
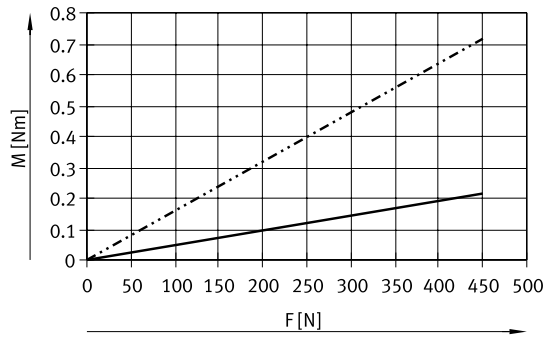

— EPCC-BS-45-3P
 - - - EPCC-BS-45-10P

— EPCC-BS-60-5P
 - - - EPCC-BS-60-12P

Datasheet

Dimensions

Download CAD data → www.festo.com

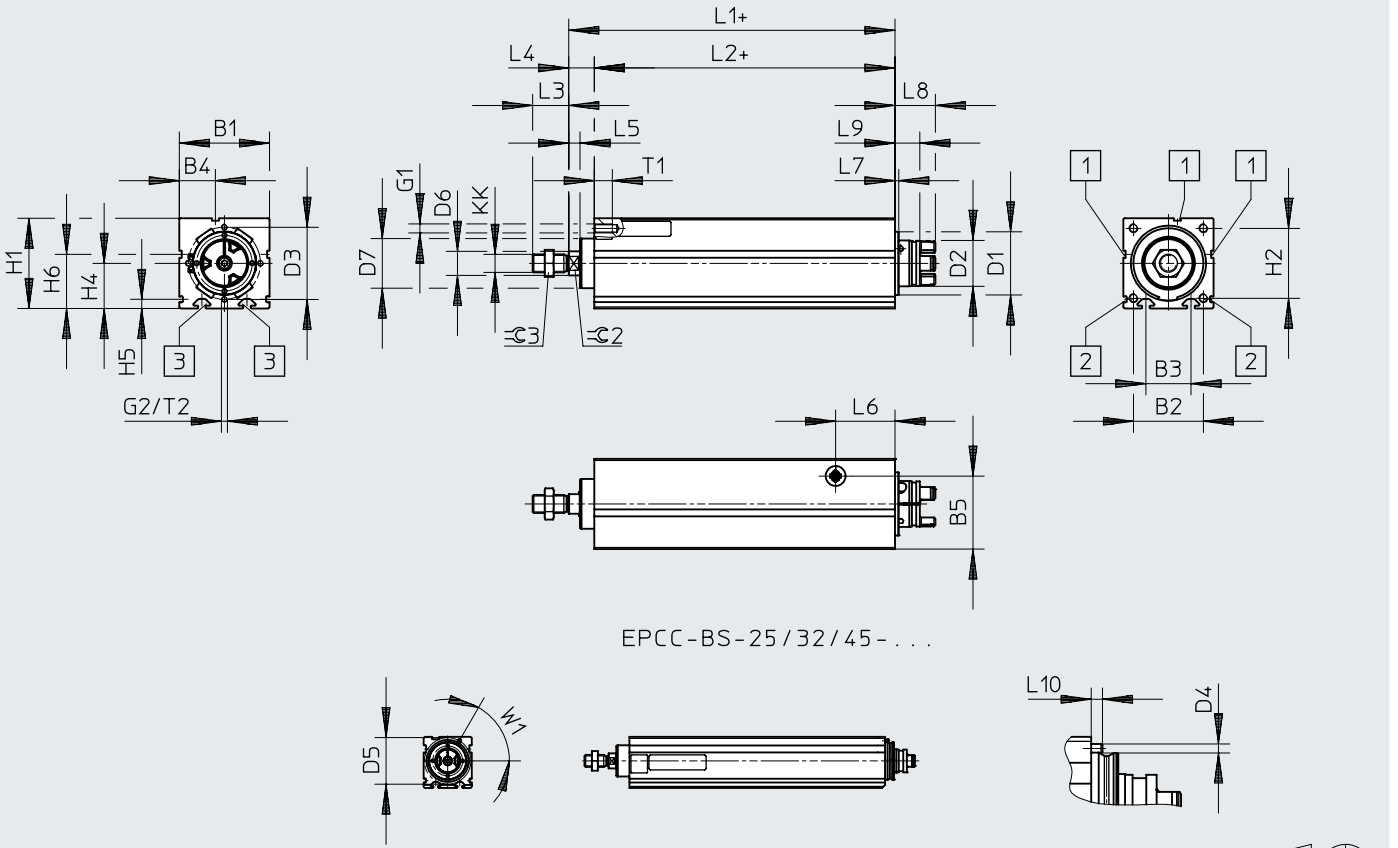

EPCC-BS-25/32/45-...

- [1] For sensor bracket
- [2] For profile mounting
- [3] For slot nut mounting

Note
Spanner flat $\approx \text{G}2$ can be aligned either way.

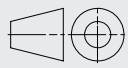

Size	B1 ±0.15	B2	B3	B4	B5	D1 ∅	D2 ¹⁾ ∅	D3 ∅	D4 ∅	D5 ∅	D6 ∅	D7 ∅
25	25	-	14	5.8	20	20.5	10.8	-	2	25	8	17.3
32	32	24	16	8.1	25.5	25	15.5	-	2	31	10	21.3
45	45	32.5	24	16.5	35	32	16.3	-	3	41	12	26.5
60	60	46.5	30	24	48.5	42	31.4	48	-	-	16	33.6

Size	G1	G2	H1 ±0.15	H2	H4	H5	H6 +0.15	KK	L1	L2	L3
25	-	-	27	-	-	4.9	22.5	M6	74.5	60	12
32	M4	-	34	24	-	4.9	26	M8	82.9	70	16
45	M5	-	45	32.5	-	6.1	28.5	M10x1.25	99.9	83	20
60	M6	M4	60	46.5	30	6.1	36	M12x1.25	116	100	24

Size	L4	L5	L6	L7	L8	L9	L10	T1	T2	W1	≈G2	≈G3
25	14.5	4.7	19.2	5	15	10.5	2.5	-	-	60°	7	10
32	12.9	5.2	24.2	6	19.9	14.5	2.5	8	-	60°	9	13
45	16.9	5.7	30.5	6	19.9	14.5	3	10	-	60°	10	16
60	16	7.5	39.5	2.5	26.9	16.5	-	12	10	-	13	18

1) Coupling diameter or interference diameter of locking screw

Datasheet

Dimensions

Download CAD data → www.festo.com

Variants

...E – Extended piston rod

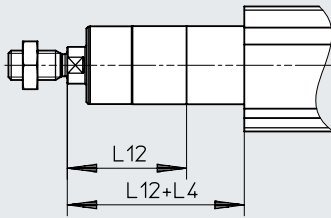

F – Female thread

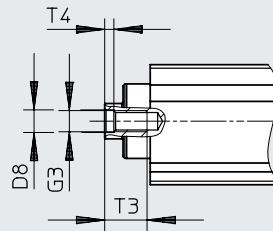

Size	L4	L12 max.	D8 ∅	G3	T3	T4
25	14.5	50	4.3	M4	10	1.5
32	12.9	100	6.4	M6	12	2.6
45	16.9	100	8.4	M8	14	3.3
60	16	100	10.5	M10	16	4.7

Datasheet

Ordering data EPCC-BS-25					
Stroke [mm]	Part no.	Type	Stroke [mm]	Part no.	Type
Spindle pitch 2 mm/rev			Spindle pitch 6 mm/rev		
25	5428805	EPCC-BS-25-25-2P-A	25	5428813	EPCC-BS-25-25-6P-A
50	5428806	EPCC-BS-25-50-2P-A	50	5428814	EPCC-BS-25-50-6P-A
75	5428807	EPCC-BS-25-75-2P-A	75	5428815	EPCC-BS-25-75-6P-A
100	5428808	EPCC-BS-25-100-2P-A	100	5428816	EPCC-BS-25-100-6P-A
125	5428809	EPCC-BS-25-125-2P-A	125	5428817	EPCC-BS-25-125-6P-A
150	5428810	EPCC-BS-25-150-2P-A	150	5428818	EPCC-BS-25-150-6P-A
175	5428811	EPCC-BS-25-175-2P-A	175	5428819	EPCC-BS-25-175-6P-A
200	5428812	EPCC-BS-25-200-2P-A	200	5428820	EPCC-BS-25-200-6P-A

EPCC-BS-32					
Stroke [mm]	Part no.	Type	Stroke [mm]	Part no.	Type
Spindle pitch 3 mm/rev			Spindle pitch 8 mm/rev		
25	5428833	EPCC-BS-32-25-3P-A	25	5428841	EPCC-BS-32-25-8P-A
50	5428834	EPCC-BS-32-50-3P-A	50	5428842	EPCC-BS-32-50-8P-A
75	5428835	EPCC-BS-32-75-3P-A	75	5428843	EPCC-BS-32-75-8P-A
100	5428836	EPCC-BS-32-100-3P-A	100	5428844	EPCC-BS-32-100-8P-A
125	5428837	EPCC-BS-32-125-3P-A	125	5428845	EPCC-BS-32-125-8P-A
150	5428838	EPCC-BS-32-150-3P-A	150	5428846	EPCC-BS-32-150-8P-A
175	5428839	EPCC-BS-32-175-3P-A	175	5428847	EPCC-BS-32-175-8P-A
200	5428840	EPCC-BS-32-200-3P-A	200	5428848	EPCC-BS-32-200-8P-A

EPCC-BS-45					
Stroke [mm]	Part no.	Type	Stroke [mm]	Part no.	Type
Spindle pitch 3 mm/rev			Spindle pitch 10 mm/rev		
25	5428858	EPCC-BS-45-25-3P-A	25	5428868	EPCC-BS-45-25-10P-A
50	5428859	EPCC-BS-45-50-3P-A	50	5428869	EPCC-BS-45-50-10P-A
75	5428860	EPCC-BS-45-75-3P-A	75	5428870	EPCC-BS-45-75-10P-A
100	5428861	EPCC-BS-45-100-3P-A	100	5428871	EPCC-BS-45-100-10P-A
125	5428862	EPCC-BS-45-125-3P-A	125	5428872	EPCC-BS-45-125-10P-A
150	5428863	EPCC-BS-45-150-3P-A	150	5428873	EPCC-BS-45-150-10P-A
175	5428864	EPCC-BS-45-175-3P-A	175	5428874	EPCC-BS-45-175-10P-A
200	5428865	EPCC-BS-45-200-3P-A	200	5428875	EPCC-BS-45-200-10P-A
250	5428866	EPCC-BS-45-250-3P-A	250	5428876	EPCC-BS-45-250-10P-A
300	5428867	EPCC-BS-45-300-3P-A	300	5428877	EPCC-BS-45-300-10P-A

EPCC-BS-60					
Stroke [mm]	Part no.	Type	Stroke [mm]	Part no.	Type
Spindle pitch 5 mm/rev			Spindle pitch 12 mm/rev		
25	5428888	EPCC-BS-60-25-5P-A	25	5428901	EPCC-BS-60-25-12P-A
50	5428889	EPCC-BS-60-50-5P-A	50	5428902	EPCC-BS-60-50-12P-A
75	5428890	EPCC-BS-60-75-5P-A	75	5428903	EPCC-BS-60-75-12P-A
100	5428891	EPCC-BS-60-100-5P-A	100	5428904	EPCC-BS-60-100-12P-A
125	5428892	EPCC-BS-60-125-5P-A	125	5428905	EPCC-BS-60-125-12P-A
150	5428893	EPCC-BS-60-150-5P-A	150	5428906	EPCC-BS-60-150-12P-A
175	5428894	EPCC-BS-60-175-5P-A	175	5428907	EPCC-BS-60-175-12P-A
200	5428895	EPCC-BS-60-200-5P-A	200	5428908	EPCC-BS-60-200-12P-A
250	5428896	EPCC-BS-60-250-5P-A	250	5428909	EPCC-BS-60-250-12P-A
300	5428897	EPCC-BS-60-300-5P-A	300	5428910	EPCC-BS-60-300-12P-A
350	5428898	EPCC-BS-60-350-5P-A	350	5428911	EPCC-BS-60-350-12P-A
400	5428899	EPCC-BS-60-400-5P-A	400	5428912	EPCC-BS-60-400-12P-A
500	5428900	EPCC-BS-60-500-5P-A	500	5428913	EPCC-BS-60-500-12P-A

Ordering data – Modular product system

Ordering table								
Size	25	32	45	60	Conditions	Code	Enter code	
Module no.	5428821	5428849	5428878	5428914				
Function	Electric cylinder					EPCC	EPCC	
Drive system	Ball screw					-BS	-BS	
Size	25	32	45	60		...		
Stroke [mm]	25					...		
	50							
	75							
	100							
	125							
	150							
	175							
	200							
	-	-		250				
	-	-		300				
	-	-			350			
	-	-			400			
	-	-			500			
Spindle pitch [mm]	2	-	-	-		...P		
	-	3	3	-				
	-	-	-	5				
	6	-	-	-				
	-	8	-	-				
	-	-	10	-				
	-	-	-	12				
Piston rod thread type	Male thread							
	Female thread					-F		
Wiper variant	None							
	Dirt wiper					-A7		
Piston rod extension [mm]	None							
	1 ... 50	1 ... 100	1 ... 100	1 ... 100		...E		
Position sensing	Via proximity switch					-A	-A	
Guide unit	None							
	-	Recirculating ball bearing guide with two guide rods			[1]	-KF		

[1] **KF** Not with piston rod extension ...E

Accessories

Note

Depending on the combination of motor and drive, it may not be possible to reach the maximum feed force of the drive.

When using parallel kits, the no-load driving torque of the particular kit must be taken into consideration.

Permissible axis/motor combinations with axial kit

Datasheets → Internet: eamm-a

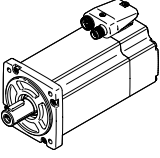
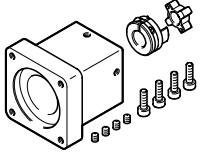
Motor/gear unit ¹⁾	Axial kit	
	 <ul style="list-style-type: none"> • Kits for third-party motors → Internet: eamm-a 	
Type	Part no.	Type
EPCC-25		
With stepper motor		
EMMS-ST-28-...	4505258	EAMM-A-V20-28A
EPCC-32		
With servo motor		
EMME-AS-40-...	4491059	EAMM-A-V25-40P
With stepper motor		
EMMS-ST-42-...	4582608	EAMM-A-V25-42A
EPCC-45		
With servo motor		
EMME-AS-40-...	4595742	EAMM-A-V32-40P
EMMT-AS-60-..., EMME-AS-60-...	4608750	EAMM-A-V32-60P
With stepper motor		
EMMS-ST-42-...	4281142	EAMM-A-V32-42A
EMMS-ST-57-...	4597016	EAMM-A-V32-57A
EPCC-60		
With servo motor		
EMMT-AS-60-..., EMME-AS-60-...	4133487	EAMM-A-T42-60P
EMMT-AS-80-..., EMME-AS-80-...	4623788	EAMM-A-T42-80P
With stepper motor		
EMMS-ST-57-...	4327034	EAMM-A-T42-57A
EMMS-ST-87-...	4610008	EAMM-A-T42-87A

1) The input torque must not exceed the maximum permissible transferable torque of the axial kit.

Accessories

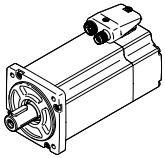
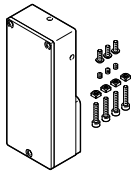
Permissible axis/motor combinations with parallel kit		Datasheets → Internet: eamm-u
Motor/gear unit ¹⁾	Parallel kit	
		<ul style="list-style-type: none"> The kit can be mounted in all directions Kits for third-party motors → Internet: eamm-u For the EPCC with guide unit, the parallel kit cannot be mounted in the area of the guide rods
Type	Part no.	Type
EPCC-25		
With stepper motor		
EMMS-ST-28-...	4767125	EAMM-U-30-V20-28A-44
EPCC-32		
With servo motor		
EMME-AS-40-...	4782056	EAMM-U-45-V25-40P-63
With stepper motor		
EMMS-ST-42-...	4825645	EAMM-U-45-V25-42A-63
EPCC-45		
With servo motor		
EMME-AS-40-...	4718297	EAMM-U-45-V32-40P-63
With stepper motor		
EMMS-ST-42-...	4280674	EAMM-U-45-V32-42A-63
EPCC-60		
With servo motor		
EMMT-AS-60-..., EMME-AS-60-...	4784301	EAMM-U-65-T42-60P-87
With stepper motor		
EMMS-ST-57-...	4331535	EAMM-U-65-T42-57A-87

1) The input torque must not exceed the max. permissible transferable torque of the parallel kit.

Accessories

Profile mounting EAHF-L2-...-P-S

Material:

Anodised wrought aluminium alloy

RoHS-compliant

- For mounting the slide on the side of the profile

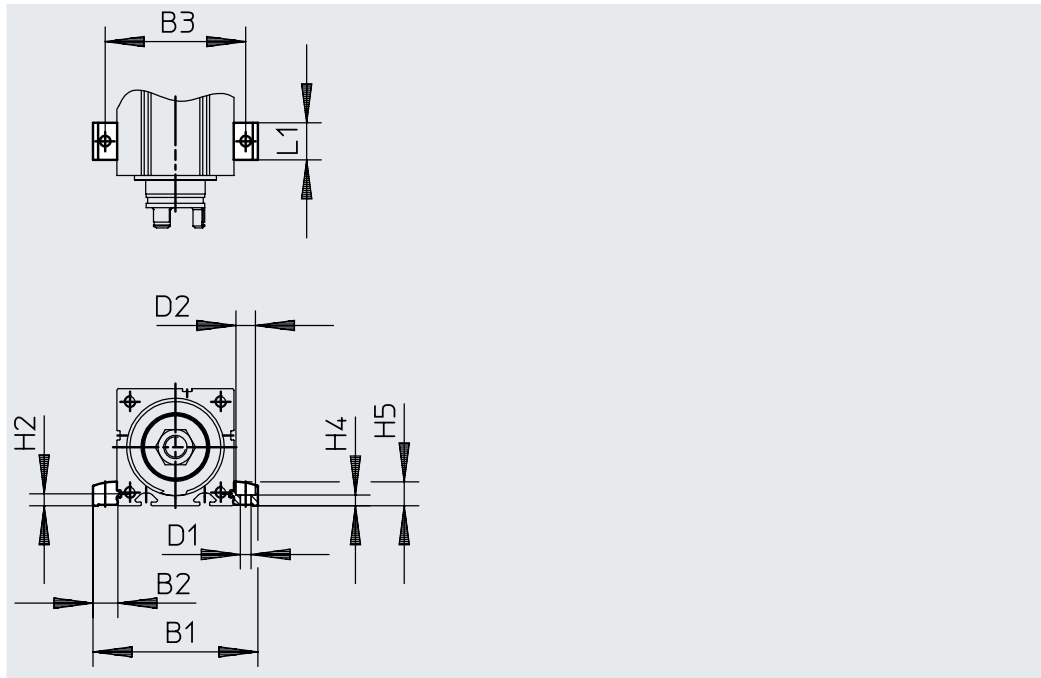
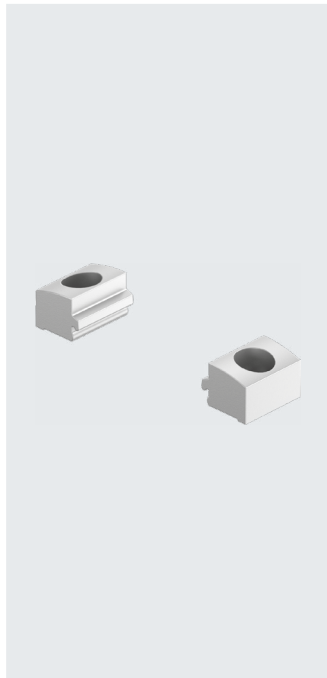

Dimensions and ordering data

For size	B1	B2	B3	D1 ∅ H13	D2 ∅ H13	H2
25	44.4	9.7	35	4.5	8	4.9
32	51.4	9.7	42	4.5	8	4.9
45	70.6	12.8	58	5.5	10	6.1
60	85.6	12.8	73	5.5	10	6.1

For size	H4 ±0.1	H5	L1	Weight [g]	Part no.	Type
25	4.2	9	19	4	5183153	EAHF-L2-25-P-S
32	4.2	9	19	4	5183153	EAHF-L2-25-P-S
45	5.5	12.2	19	6	5184133	EAHF-L2-45-P-S
60	5.5	12.2	19	6	5184133	EAHF-L2-45-P-S

Accessories

Profile mounting EAHF-L2-...-P

Material:

Anodised wrought aluminium alloy

RoHS-compliant

- For mounting the slide on the side of the profile.

The profile mounting can be attached to the mounting surface using the drilled hole in the centre

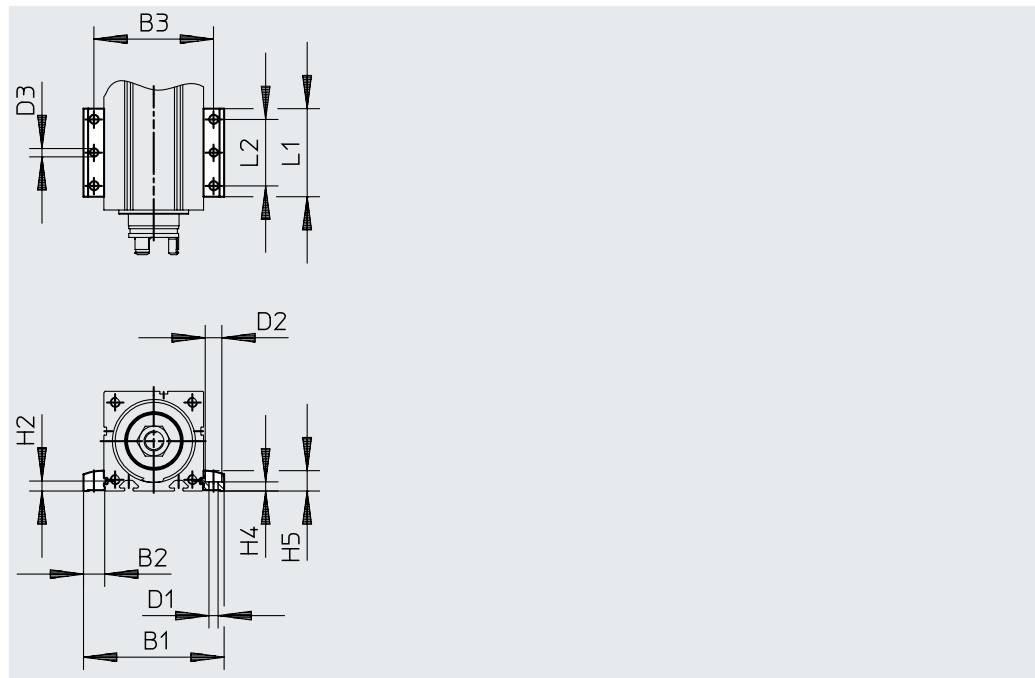

Dimensions and ordering data

For size	B1	B2	B3	D1 ∅ H13	D2 ∅ H13	D3 ∅	H2
25	44.4	9.7	35	4.5	8	4	4.9
32	51.4	9.7	42	4.5	8	4	4.9
45	70.6	12.8	58	5.5	10	5	6.1
60	85.6	12.8	73	5.5	10	5	6.1

For size	H4 ±0.1	H5	L1	L2	Weight [g]	Part no.	Type
25	4.2	9	53	40	19	4835684	EAHF-L2-25-P
32	4.2	9	53	40	19	4835684	EAHF-L2-25-P
45	5.5	12.2	53	40	35	4835728	EAHF-L2-45-P
60	5.5	12.2	53	40	35	4835728	EAHF-L2-45-P

Accessories

Flange mounting EAHH

Material:
Galvanised steel
RoHS-compliant

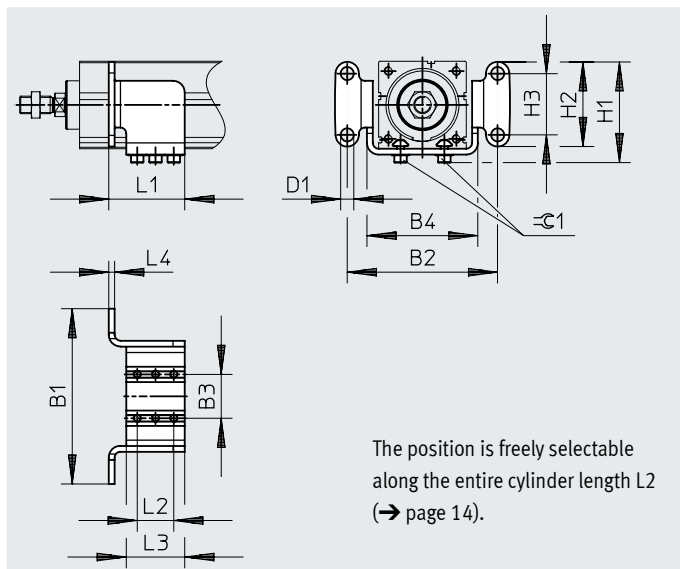
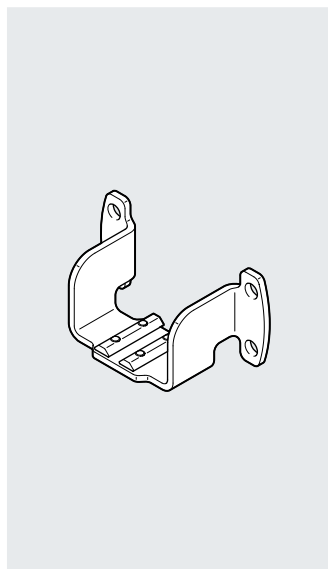

Dimensions and ordering data

For size	B1	B2	B3 ±0.1	B4	D1 ∅	H1	H2	H3	L1
25	61	50	14	35	4.5	32.5	25	15	38
32	70	58	16	42	5.5	39	31	20	38
45	100	85	24	61	6.6	54.5	48	35	42
60	120	103	30	76	9	69	58	42	52

For size	L2	L3	L4	∅C1	CRC ¹⁾	Weight [g]	Part no.	Type
25	20	30	2.5	2.5	1	65	5127286	EAHH-P2-25
32	20	30	2.5	2.5	1	80	5126157	EAHH-P2-32
45	20	30	4	2.5	1	185	5126669	EAHH-P2-45
60	25	40	4	4	1	320	5127005	EAHH-P2-60

1) Corrosion resistance class CRC 1 to Festo standard FN 940070

Low corrosion stress. Dry internal application or transport and storage protection. Also applies to parts behind covers, in the non-visible interior area, or parts that are covered in the application (e.g. drive trunnions).

Accessories

Adapter kit EAHA

Material:
Galvanised steel

RoHS-compliant

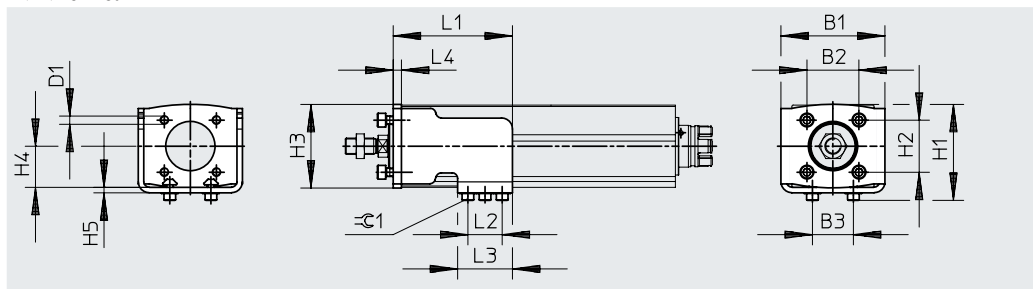
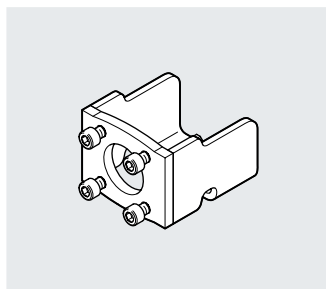

Dimensions and ordering data

For size	B1	B2	B3	D1	H1	H2	H3	H4	H5
		±0.2	±0.1			±0.2			
25	37	18	14	M4	35	18	30	14.5	2.5
32	53	22	16	M5	42	22	37	18	2.5
45	61	32.5	24	M6	54	32.5	49	22.5	4
60	76	38	30	M6	69.5	38	61	30	4

For size	L1	L2	L3	L4	≅G1	CRC ¹⁾	Weight [g]	Part no.	Type
25	58	20	30	4	2.5	1	110	5172843	EAHA-P2-25
32	64	20	30	4	2.5	1	165	5173020	EAHA-P2-32
45	68	20	30	6	2.5	1	340	5172353	EAHA-P2-45
60	87	25	40	6	4	1	560	5173082	EAHA-P2-60

1) Corrosion resistance class CRC 1 to Festo standard FN 940070

Low corrosion stress. Dry internal application or transport and storage protection. Also applies to parts behind covers, in the non-visible interior area, or parts that are covered in the application (e.g. drive trunnions).

Accessories

Swivel mounting EAHS

Material:
Galvanised steel
RoHS-compliant

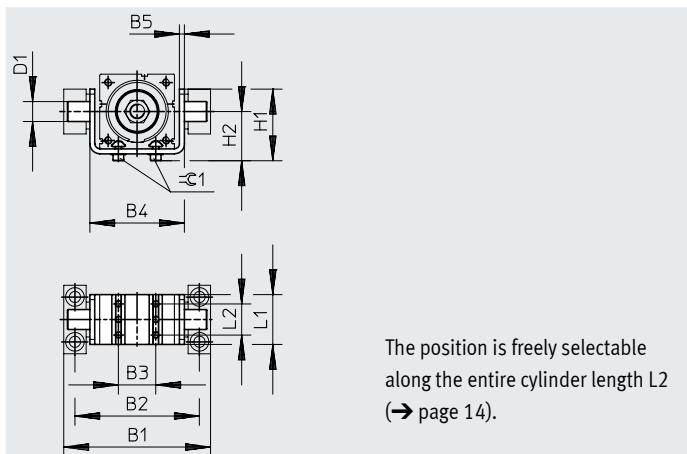
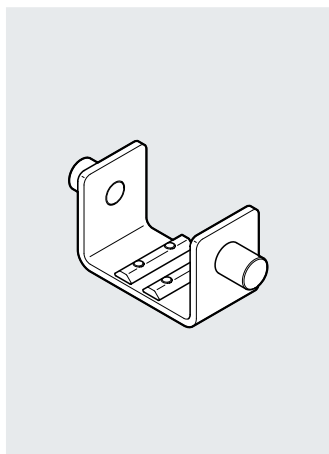

The position is freely selectable along the entire cylinder length L2 (→ page 14).

Dimensions and ordering data

For size	B1	B2	B3 ±0.1	B4	B5	D1 ∅ e9	H1
25	61	50	14	35	2.5	8	30
32	68	57	16	42	2.5	8	32
45	98	83	24	62	4	12	44.5
60	118	100	30	76	4	16	57

For size	H2	L1	L2	∅C1	CRC ¹⁾	Weight [g]	Part no.	Type
25	20	30	20	2.5	1	70	5125383	EAHS-P2-25
32	23.5	30	20	2.5	1	75	5125041	EAHS-P2-32
45	29.5	30	20	2.5	1	165	5125167	EAHS-P2-45
60	39	40	25	4	1	305	5125281	EAHS-P2-60

1) Corrosion resistance class CRC 1 to Festo standard FN 940070
Low corrosion stress. Dry internal application or transport and storage protection. Also applies to parts behind covers, in the non-visible interior area, or parts that are covered in the application (e.g. drive trunnions).

Trunnion support LNZG

Material:
Trunnion support: Anodised aluminium
Plain bearing: Plastic
Free of copper and PTFE
RoHS-compliant

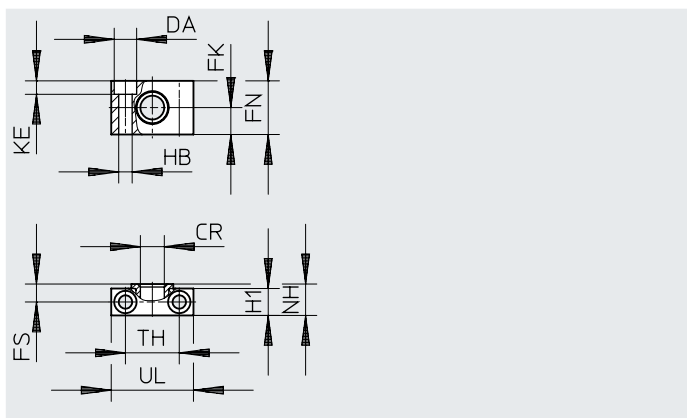

Dimensions and ordering data

For size	CR ∅ D11	DA ∅ H13	FK ∅ ±0.1	FN	FS	H1	HB ∅ H13	KE	NH	TH ±0.2	UL	CRC ¹⁾	Weight [g]	Part no.	Type
25, 32	8	8	10	20	7.5	11	4.5	4.6	13	20	30	2	26	1434912	LNZG-16
45	12	11	15	30	10.5	15	6.6	6.8	18	32	46	2	83	32959	LNZG-32
60	16	15	18	36	12	18	9	9	21	36	55	2	129	32960	LNZG-4 0/50

1) Corrosion resistance class CRC 2 to Festo standard FN 940070
Moderate corrosion stress. Indoor applications in which condensation can occur. External visible parts with primarily decorative surface requirements that are in direct contact with a normal industrial environment.

Accessories

Swivel flange SNCS

Material:
Die-cast aluminium

Free of copper and PTFE
RoHS-compliant

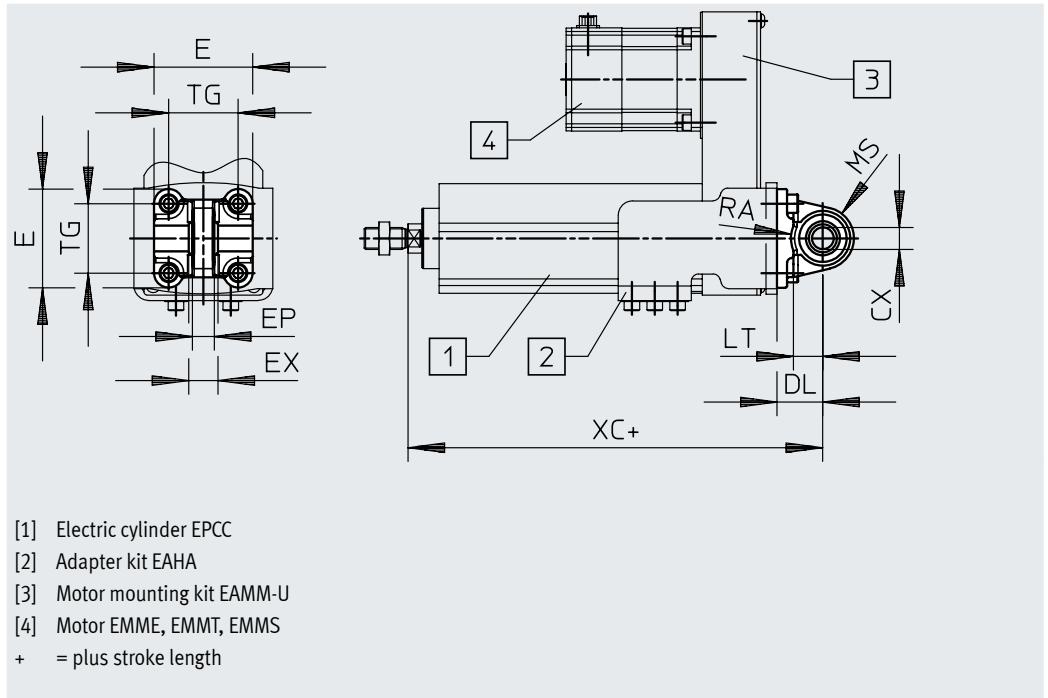
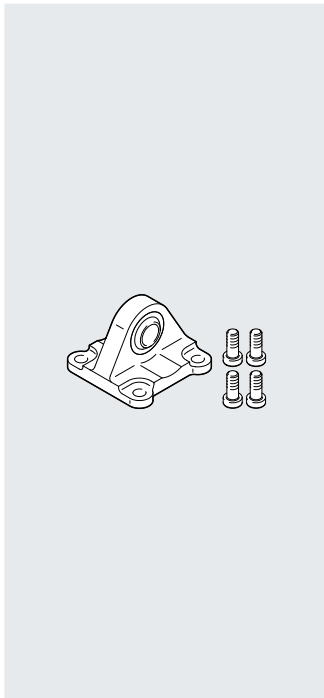

- [1] Electric cylinder EPCC
- [2] Adapter kit EAHA
- [3] Motor mounting kit EAMM-U
- [4] Motor EMME, EMMT, EMMS
- + = plus stroke length

Dimensions and ordering data

For size	CX	DL	E	L	EP	EX	LT
		±0.2			±0.2		
45	10 ^{+0.13}	22	45 ^{+0.2/-0.5}	3	10.5	14	13
60	12 ^{+0.15}	25	54 ^{-0.5}	3	12	16	16

For size	MS	RA	TG	XC	CRC ¹⁾	Weight	Part no.	Type
						[g]		
45	15	14.5	32.5	154.9	1	86	174397	SNCS-32
60	17	17.5	38	182	1	122	174398	SNCS-40

1) Corrosion resistance class CRC 1 to Festo standard FN 940070

Low corrosion stress. Dry internal application or transport and storage protection. Also applies to parts behind covers, in the non-visible interior area, or parts that are covered in the application (e.g. drive trunnions).

Accessories

Swivel flange SNCL

Material:
Wrought aluminium alloy

Free of copper and PTFE
RoHS-compliant

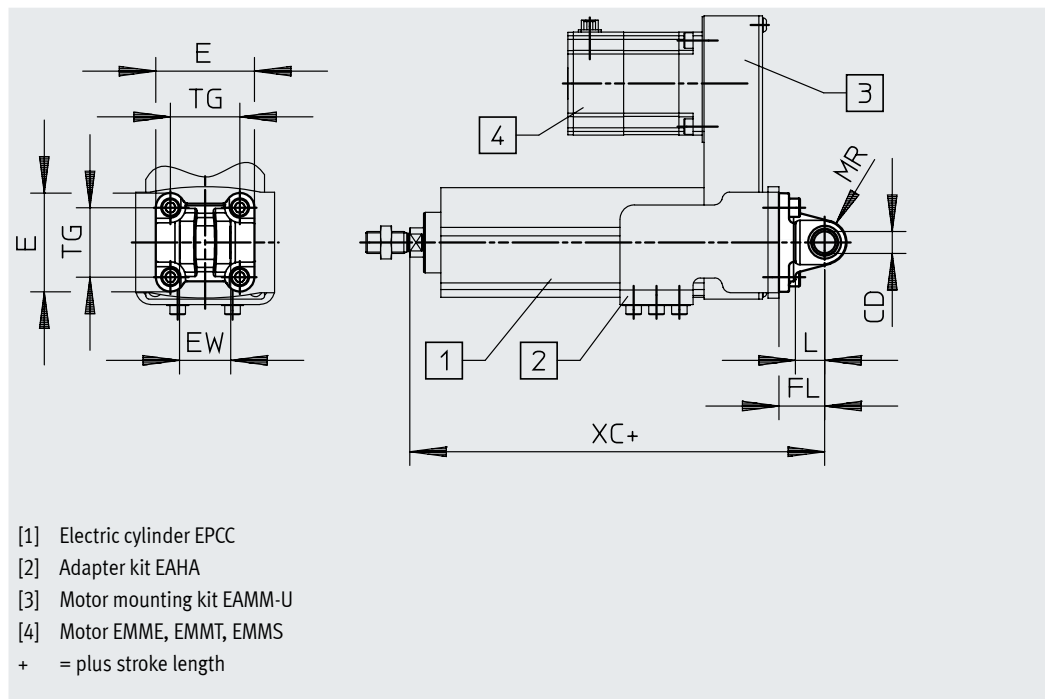
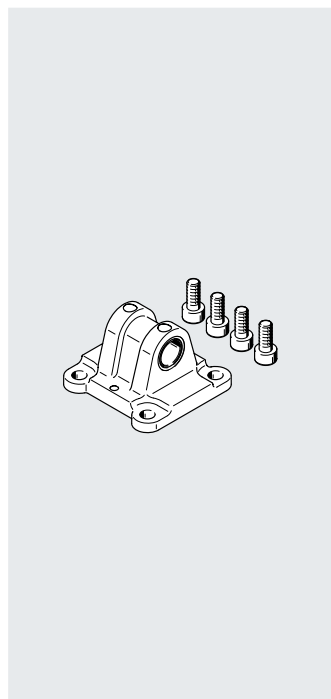

Dimensions and ordering data

For size	CD ∅ H10	E	EW h12	FL ±0.2	L	LT
25	6	27.5 _{-0.6}	12 _{h12}	16	3	10
32	8	34.5 _{-0.6}	16 _{h12}	20	3	14
45	10	45 _{+0.2/-0.5}	26 _{-0.2/-0.6}	22	3	13
60	12	54 _{-0.5}	28 _{-0.2/-0.6}	25	3	16

For size	MR	TG	XC	CRC ¹⁾	Weight [g]	Part no.	Type
25	6	18	115.7	2	21	537791	SNCL-16
32	8	22	133.9	2	38	537792	SNCL-20
45	10	32.5	154.9	1	71	174404	SNCL-32
60	12	38	182	1	95	174405	SNCL-40

1) Corrosion resistance class CRC 1 to Festo standard FN 940070
Low corrosion stress. Dry internal application or transport and storage protection. Also applies to parts behind covers, in the non-visible interior area, or parts that are covered in the application (e.g. drive trunnions).

Corrosion resistance class CRC 2 to Festo standard FN 940070
Moderate corrosion stress. Indoor applications in which condensation can occur. External visible parts with primarily decorative surface requirements that are in direct contact with a normal industrial environment.

Accessories

Swivel flange SNCB

Material:
Die-cast aluminium

Free of copper and PTFE
RoHS-compliant

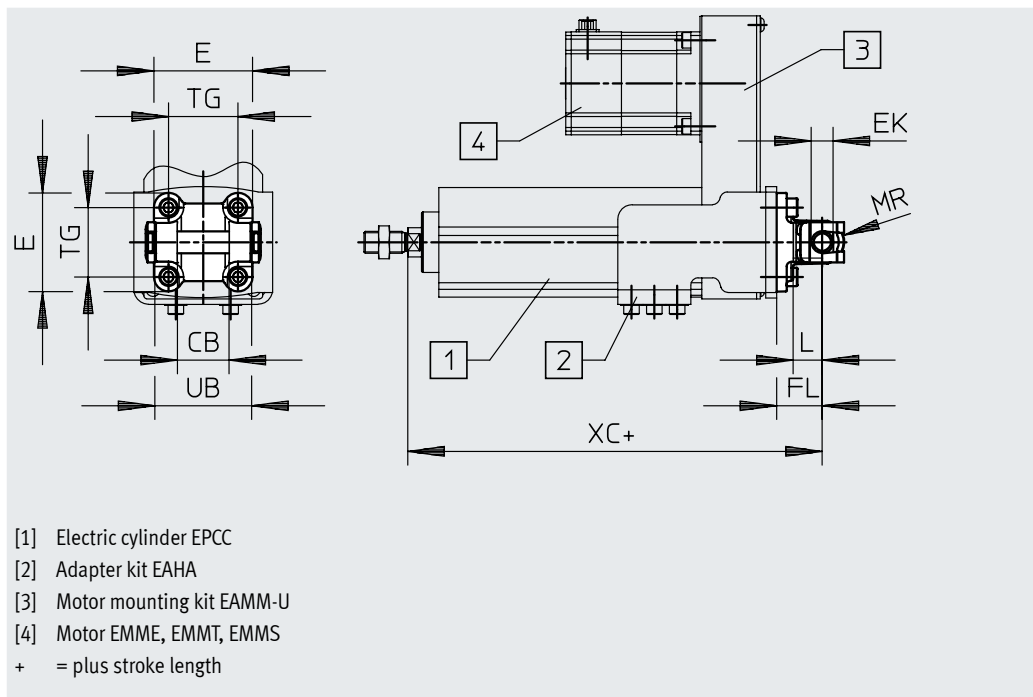
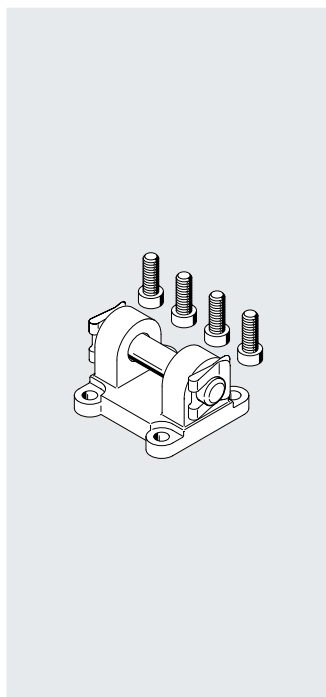

- [1] Electric cylinder EPCC
- [2] Adapter kit EAHA
- [3] Motor mounting kit EAMM-U
- [4] Motor EMME, EMMT, EMMS
- + = plus stroke length

Dimensions and ordering data

For size	CB	E	EK ∅ H10/e8	FL ±0.2	L	LT	MR -0.5
45	26	45 ^{+0.2/-0.5}	10	22	3	13	8.5
60	28	54 ^{-0.5}	12	25	3	16	12

For size	TG	UB h14	XC	CRC ¹⁾	Weight [g]	Part no.	Type
45	32.5	45	154.9	1	103	174390	SNCB-32
60	38	52	182	1	155	174391	SNCB-40

1) Corrosion resistance class CRC 1 to Festo standard FN 940070
Low corrosion stress. Dry internal application or transport and storage protection. Also applies to parts behind covers, in the non-visible interior area, or parts that are covered in the application (e.g. drive trunnions).

Accessories

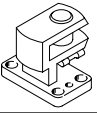
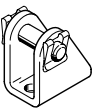

Ordering data – Mounting components

Designation	For size	Part no.	Type
Right angle clevis foot LQG			
	45	31768	LQG-32
	60	31769	LQG-40
Clevis foot LBN			
	25	6058	LBN-1 2/16
	32	6059	LBN-2 0/25

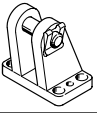

Datasheets → Internet: clevis foot

Designation	For size	Part no.	Type
Clevis foot LBG			
	45	31761	LBG-32
	60	31762	LBG-40

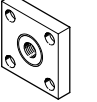
Ordering data – Piston rod attachments

Designation	For size	Part no.	Type
Rod eye SGS			
	25	9254	SGS-M6
	32	9255	SGS-M8
	45	9261	SGS-M10x1.25
	60	9262	SGS-M12x1.25
Self-aligning rod coupler FK			
	25	2061	FK-M6
	32	2062	FK-M8
	45	6140	FK-M10x1.25
	60	6141	FK-M12x1.25
Coupling piece KSG			
	45	32963	KSG-M10x1.25
	60	32964	KSG-M12x1.25

Datasheets → Internet: piston rod attachment

Designation	For size	Part no.	Type
Rod clevis SG			
	25	3110	SG-M6
	32	3111	SG-M8
	45	6144	SG-M10x1.25
	60	6145	SG-M12x1.25
Rod clevis SGA			
	45	32954	SGA-M10x1.25
	60	10767	SGA-M12x1.25

Ordering data – Push-in fitting for sealing air connection

	For size	Part no.	Type	PU ¹⁾
	25	133003	QSM-M5-3-I-R	10
		133004	QSM-M5-4-I-R	
	32	133003	QSM-M5-3-I-R	
		133004	QSM-M5-4-I-R	
	45	186266	QSM-G1/8-4-I	
		186267	QSM-G1/8-6-I	
	60	186108	QS-G1/4-6-I	
		186110	QS-G1/4-8-I	

1) Packaging unit

Ordering data – Slot nut

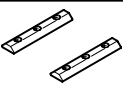
	For size	Description	Part no.	Type	PU ¹⁾
	25, 32, 45	For mounting the electric cylinder	8169987	ABAN-3-3M3-30-M-P2	2
	60		8169988	ABAN-5-3M5-40-M-P2	

1) Packaging unit

Accessories

Ordering data – Guide units

Datasheets → Internet: eagf

Stroke [mm]	Part no.	Type
For size 32		
50	8158032	EAGF-P2-KF-32-50
100	8158029	EAGF-P2-KF-32-100
150	8158027	EAGF-P2-KF-32-150
200	8158028	EAGF-P2-KF-32-200
25, 75, 125, 175	8158030	EAGF-P2-KF-32-
For size 45		
50	8158131	EAGF-P2-KF-45-50
100	8158123	EAGF-P2-KF-45-100
150	8158125	EAGF-P2-KF-45-150
200	8158127	EAGF-P2-KF-45-200
300	8158130	EAGF-P2-KF-45-300
25, 75, 125, 175, 250	8158133	EAGF-P2-KF-45-
For size 60		
100	8158138	EAGF-P2-KF-60-100
150	8158140	EAGF-P2-KF-60-150
200	8158142	EAGF-P2-KF-60-200
300	8158031	EAGF-P2-KF-60-300
25, 50, 75, 125, 175, 250, 350, 400, 500	8158150	EAGF-P2-KF-60-

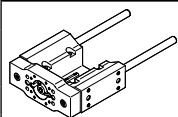

Accessories

Sensor bracket EAPM-L2

Material:
Anodised wrought aluminium alloy
RoHS-compliant

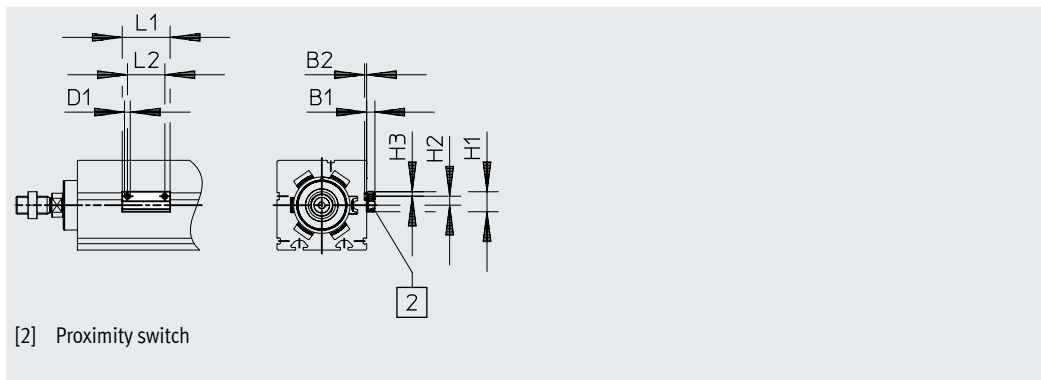
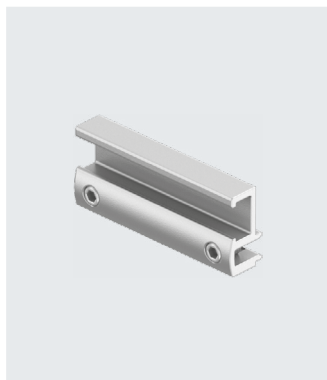

Dimensions and ordering data						
For size	B1	B2	D1	H1	H2	
25, 32, 45, 60	5.5	1.3	M4	13.4	6	
For size	H3	L1	L2	Weight [g]	Part no.	Type
25, 32, 45, 60	3	32	25	4	4759852	EAPM-L2-SH

Ordering data – Proximity switch for T-slot, magneto-resistive							Datasheets → Internet: smt
	Type of mounting	Switching output	Electrical connection	Cable length [m]	Part no.	Type	
N/O							
	Inserted in the slot from above, flush with the cylinder profile, short design	PNP	Cable, 3-core	2.5	574335	SMT-8M-A-PS-24V-E-2.5-OE	
			Plug M8x1, 3-pin	0.3	574334	SMT-8M-A-PS-24V-E-0.3-M8D	
		NPN	Cable, 3-core	2.5	574338	SMT-8M-A-NS-24V-E-2.5-OE	
			Plug M8x1, 3-pin	0.3	574339	SMT-8M-A-NS-24V-E-0.3-M8D	
N/C							
	Inserted in the slot from above, flush with the cylinder profile, short design	PNP	Cable, 3-core	7.5	574340	SMT-8M-A-PO-24V-E-7.5-OE	
				2.5	8138000	SMT-8M-A-NO-24V-E-2.5-OE	
		NPN		7.5	8138001	SMT-8M-A-NO-24V-E-7.5-OE	

Ordering data – Connecting cables							Datasheets → Internet: nebu
	Electrical connection, left	Electrical connection, right	Cable length [m]	Part no.	Type		
	Straight socket, M8x1, 3-pin	Cable, open end, 3-core	2.5	541333	NEBU-M8G3-K-2.5-LE3		
			5	541334	NEBU-M8G3-K-5-LE3		
	Angled socket, M8x1, 3-pin	Cable, open end, 3-core	2.5	541338	NEBU-M8W3-K-2.5-LE3		
			5	541341	NEBU-M8W3-K-5-LE3		