

Spindle axis units ELGS-BS-KF

FESTO



This product is also available as a modular mechanical system
Spindle axis ELGC-BS-KF



Key features

At a glance

Plug and work with the Simplified Motion Series



The simplicity of pneumatics is now combined for the first time with the advantages of electric automation thanks to the Simplified Motion Series. These integrated drives are the perfect solution for all users who are looking for an electric alternative for very simple movement and positioning tasks between two mechanical end positions, but don't want the commissioning process for traditional electric drive systems that can often be quite complex.



There is no need for any software since operation is simply based on the "plug and work" principle. Digital I/O (DIO) and IO-Link are always automatically included – a product with two types of control as standard.

Integrated

The integrated electronics in the drive are at the heart of the Simplified Motion Series.

Easy

For commissioning, simply set all relevant parameters directly on the drive:

- Speed and force
- Reference end position and cushioning
- Manual operation

Standardised

Electrical connection via M12 plug design

- Power (4-pin): power supply for the motor
- Logic (8-pin): control signal, sensor signal and power for the integrated electronics

Connected

Use of extended functions possible via IO-Link:

- Remote configuration of motion parameters
- Copy and backup function for transferring parameters
- Read function for extended process parameters
- Freely definable intermediate position
- Firmware update

The functions of the Simplified Motion Series

Basic profile for movement between two end positions: with speed control

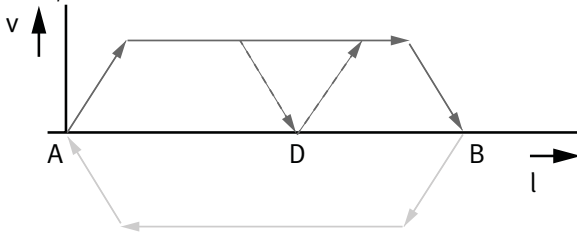

Extended motion profile for simplified press-fitting and clamping functions: with speed and force control

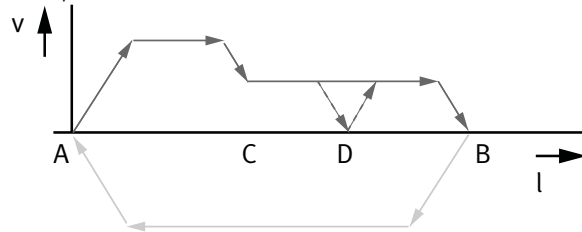

- These drives are designed for simple movements between two end positions.
- Proximity switches are required in order to implement any intermediate positions.
- With the intermediate position that can be freely configured via IO-Link, movements can be stopped at a freely defined point between the end positions, without the need for proximity switches or external stops

Key features

At a glance



- Without external servo drive: all the necessary electronic components are combined in the integrated drive
- Two control options integrated as standard: digital I/O and IO-Link
- Complete solution for simple movements between mechanical end positions
- Protected against external influences by internal guide
- Simplified commissioning: all parameters can be manually set directly on the drive
- No special expertise required for commissioning
- End-position feedback similar to that of a conventional proximity switch is integrated as standard
- Clean Look design: easy to clean and less prone to contamination

The products in the Simplified Motion Series

Electric cylinder unit
EPCE



Mini slide unit
EGSS-BS-KF

Electric cylinder unit
EPCS



Mini slide unit with parallel motor mounting
EGSS-BS-KF

Electric cylinder unit with parallel motor mounting
EPCS



Spindle axis unit
ELGS-BS-KF

Spindle axis unit with parallel motor mounting
ELGS-BS-KF



Toothed belt axis unit
ELGS-TB-KF



Toothed belt axis unit
ELGE



Rotary drive unit
ERMS



Modular and flexible with motor, motor mounting kit and servo drive

This product is also available as a modular mechanical system as spindle axis ELGC-BS-KF:



When compact dimensions and optimised installation space are important, e.g. for assembly systems, test and inspection systems, small parts handling, the electronics industry and desktop applications. Either as an individual axis or as a handling system.

- Compact: optimum ratio of installation space to working space
- Unique: "one-size-down" mounting system
- Modular: individual combinations with motor, motor mounting kit and servo drive
- Flexible: wide range of mounting options for optimum machine integration

Key features

Combination matrix between axis ELGC-TB/ELGS-TB, ELGC-BS/ELGS-BS, mini slide EGSC-BS/EGSS-BS, electric cylinder EPCC-BS/EPCS-BS and guide axis ELFC
 Mounting options with profile mounting and with angle kit

	Size	Assembly axis ELGC-BS/-TB; ELFC; EGSC-BS; EPCC-BS; ELGS-BS/-TB; EGSS-BS; EPCS-BS			
		25	32	45	60
Base axis	32	■	-	-	-
ELGC-BS/-TB; ELFC;	45	-	■	-	-
ELGS-BS/-TB	60	-	-	■	-
	80	-	-	-	■

With profile mounting EAHF-L2-....P-D...

With angle kit EHAA-D-L2-....AP

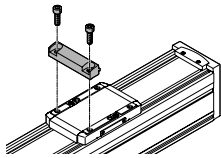

- Mounting option: base axis with one-size-down assembly axis

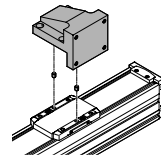

- Mounting option: base axis rotated through 90° with one-size-down assembly axis

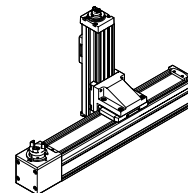
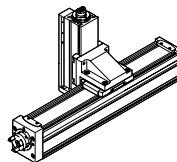
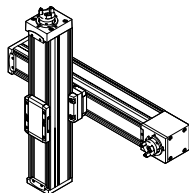
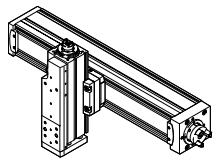

Key features

Combination matrix between axis ELGC/ELGS-TB, ELGC/ELGS-BS, mini slide EGSC/EGSS-BS, electric cylinder EPCC/EPCS-BS and guide axis ELFC

Mounting options with adapter kit or direct fastening

	Size	Assembly axis ELGC-BS/-TB; ELFC; EGSC-BS; EPCC-BS; ELGS-BS/-TB; EGSS-BS, EPCS-BS				
		25	32	45	60	80
Base axis	32		■	-	-	-
ELGC-BS/-TB; ELFC; ELGS-BS/-TB	45	-		■	-	-
	60	-	-		■	-
	80	-	-	-		■

	Size	Assembly axis EGSC-BS; EGSS-BS			
		25	32	45	60
Base axis	25		■	-	-
EGSC-BS; EGSS-BS	32	-		■	-
	45	-	-		■
	60	-	-	-	

With adapter kit EHAA-D-L2

- Mounting option: base axis with the same size assembly axis
- Mounting option: base axis with height compensation for one-size-down assembly axis
- When motors are mounted using parallel kits, this may lead to interfering contours. In this case, the adapter plate is required for height compensation

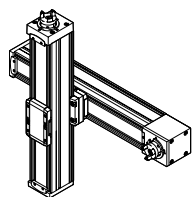
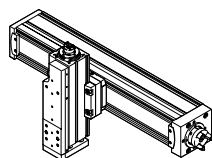
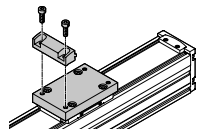

With direct mounting

- Mounting option: base axis with the same size assembly axis

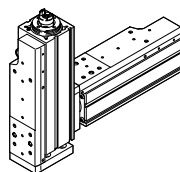

Key features

Typical handling systems

For applications where compact dimensions are essential, the axes ELGC can be combined into very space-saving handling systems that are suitable for assembly systems, test and inspection systems, small parts handling, the electronics industry and desktop applications. Combining the very compact linear axes ELGC, mini slide EGSC and electric cylinder EPCC offers an optimum ratio of installation space to working space. These feature a common system approach and platform architecture and the connections are largely adapterless.

Cantilever system

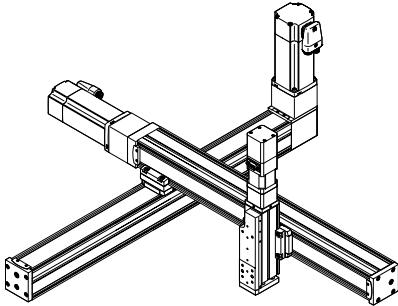

Planar surface gantry

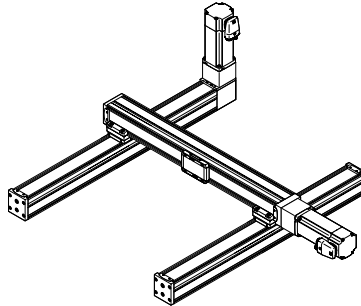

Three dimensional gantry

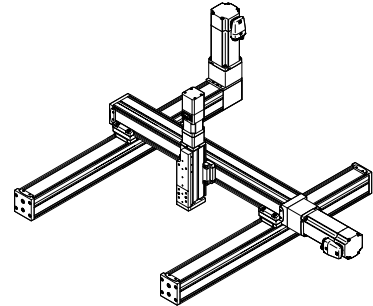

Type codes

001	Series	
ELGS	Gantry axis	

002	Drive system	
BS	Ball screw drive	

003	Guide	
KF	Recirculating ball bearing guide	

004	Size	
32	32	
45	45	
60	60	

005	Stroke [mm]	
100	100	
200	200	
300	300	
400	400	
500	500	
600	600	
800	800	

006	Spindle pitch	
	Standard	
8P	8 mm	
10P	10 mm	
12P	12 mm	

007	Motor type	
ST	Stepper motor ST	

008	Controller	
M	Integrated	

009	Control panel	
H1	Integrated	

010	Bus protocol/activation	
PLK	PNP and IO-Link®	
NLK	NPN and IO-Link®	

011	End-position sensing	
AA	With integrated end-position sensing	

012	Cable outlet direction	
	Standard	
D	Underneath	
F	Front	
B	Rear	

013	Motor attachment position	
	Standard	
PB	Parallel, rear	
PF	Parallel, front	
PD	Parallel, bottom	

014	Electrical accessories	
	None	
L1	Adapter for operation as IO-Link® device	

015	Operating instructions	
	With operating instructions	
DN	Without operating instructions	

Peripherals overview

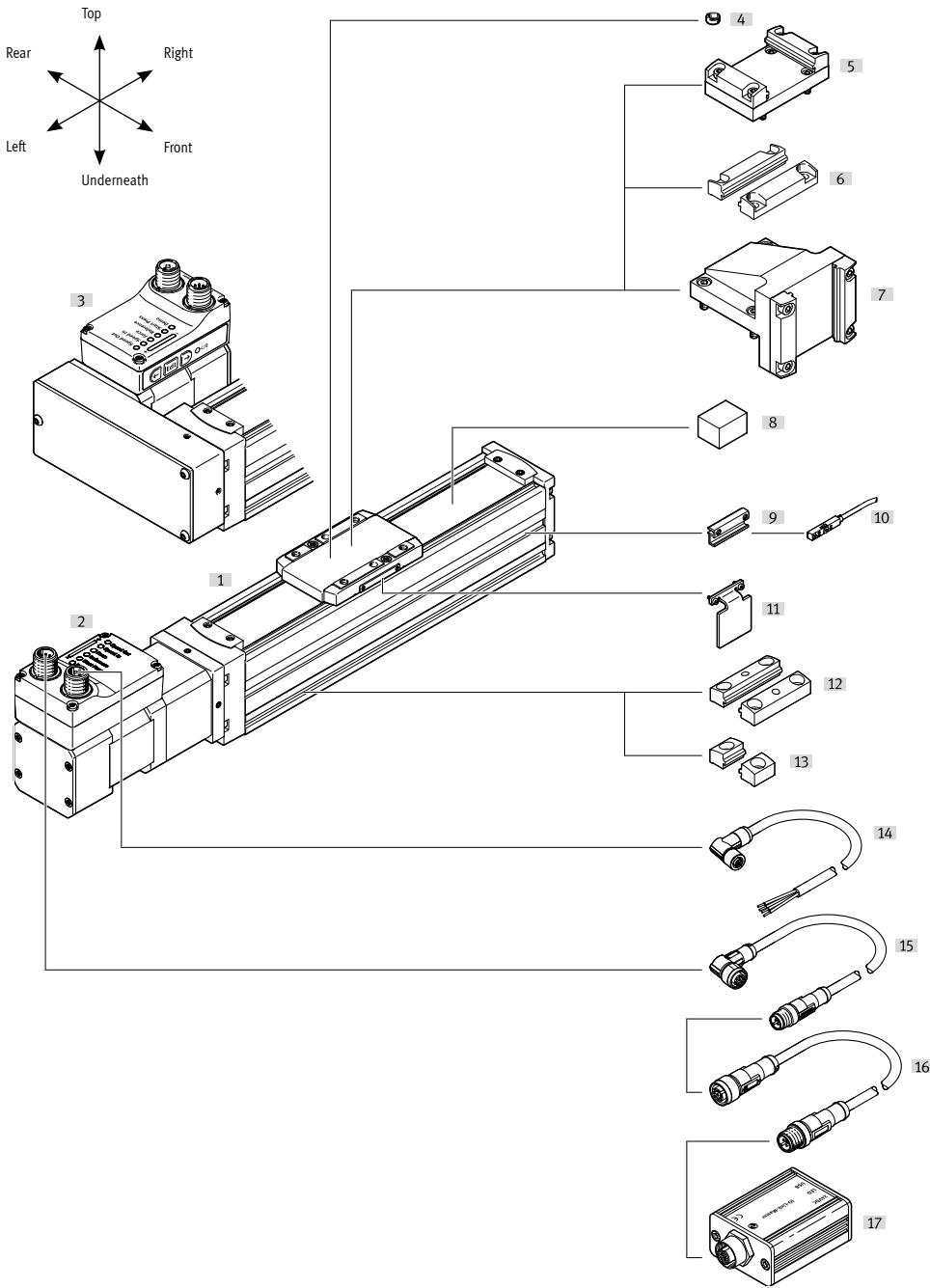

Accessories			
Type/order code	Description		→ Page/Internet
[1] Spindle axis unit ELGS-BS	Electric drive		8
[2] Axial kit	For axial motor mounting (included in the scope of delivery)		9
[3] Parallel kit	For parallel motor mounting (included in the scope of delivery)		9
[4] Centring pin/sleeve ZBS, ZBH	For centring loads and attachments on the slide		36
[5] Adapter kit EHAA-D-L2	<ul style="list-style-type: none"> For axis/axis mounting with adapter plate Mounting option: base axis with the same size or one-size-down assembly axis When motors are mounted using parallel kits, this may lead to interfering contours. In this case, the adapter plate is required for height compensation (download CAD data → www.festo.com) 		33
[6] Profile mounting EAHF-L2-...-P-D	<ul style="list-style-type: none"> For axis/axis mounting without adapter plate Mounting option: base axis with one-size-down assembly axis 		32

Peripherals overview

Accessories			
Type/order code	Description		→ Page/Internet
[7] Angle kit EHAA-D-L2-...-AP	<ul style="list-style-type: none"> For mounting one-size-down vertical axes (assembly axes) on base axes with mounting position "slide at top" 		34
[8] Clamping element EADT-S-L5-32	<ul style="list-style-type: none"> Tool for retensioning the cover strip 		36
[9] Sensor bracket ¹⁾ EAPM-L2-SH	For mounting the proximity switches on the axis. The proximity switches can only be mounted using the sensor bracket		35
[10] Proximity switches ¹⁾ SIES-8M	Inductive proximity switches, for T-slot		36
Proximity switches ¹⁾ SMT-8M	Magnetic proximity switches, for T-slot		36
[11] Switch lug ¹⁾ EAPM-...-SLS	For sensing the slide position in conjunction with inductive proximity switches SIES-8M		35
[12] Profile mounting EAHF-L2-...-P	For mounting the axis on the side of the profile. The profile mounting can be attached to the mounting surface using the drill hole in the centre		31
[13] Profile mounting EAHF-L2-...-	For mounting the axis on the side of the profile		30
[14] Supply cable NEBL-T12	For connecting load and logic supply		37
[15] Connecting cable NEBC-M12	For connection to a controller		37
[16] Adapter NEFC-M12G8	<ul style="list-style-type: none"> Connection between the motor and the IO-Link master Only recommended for use with IO-Link port class A master 		37
[17] IO-Link master USB CDSU-1	For straightforward use of the mini slide unit via IO-Link		37

1) Proximity switches are optional and only required in order to sense any intermediate positions.

Control elements

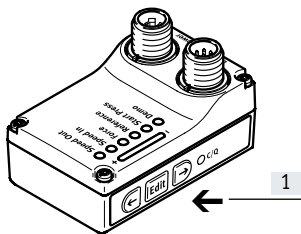

[1] Pushbutton actuators for parameterisation and control

Cable outlet direction

Standard

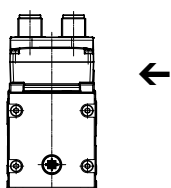

[D] Underneath

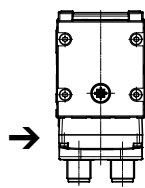

[B] Rear

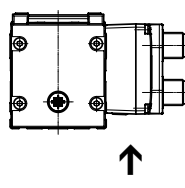

[F] Front

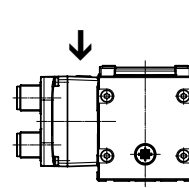

Motor attachment variants

Standard

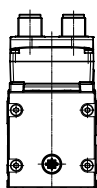

[PD] Underneath

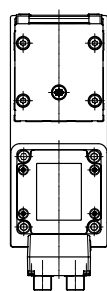

[PB] Rear

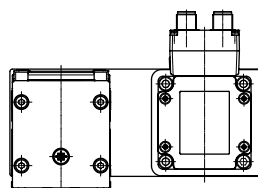

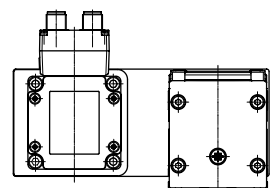

[PF] Front

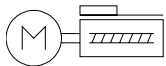

Datasheet

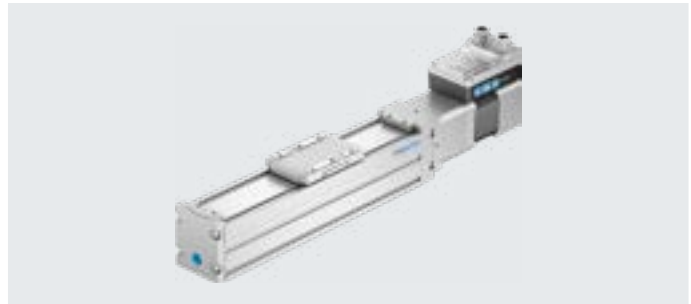

-  - Size
32 ... 60
-  - Stroke length
100 ... 800 mm

**General technical data**

Size	32	45	60
Design	Electromechanical axis with ball screw and integrated drive		
Motor type	Stepper motor		
Guide	Recirculating ball bearing guide		
Mounting position	Any		
Working stroke [mm]	100, 200, 300, 400, 500, 600, 800	100, 200, 300, 400, 500, 600, 800	100, 200, 300, 400, 500, 600, 800
Stroke reserve [mm]	0		
Additional functions	Built-in end-position sensing		
	User interface		
Display	LED		
Homing	Positive fixed stop block		
	Negative fixed stop block		
Type of mounting	With female thread		
	With accessories		
	With centring pin, centring sleeve		
Max. cable length			
Inputs/outputs [m]	15		
IO-Link operation [m]	20		

Mechanical data

Size	32	45	60
Max. payload			
Horizontal [kg]	2	10	20
Vertical [kg]	2	5	13
Max. feed force F_x [N]	40	100	200
Repetition accuracy [mm]	±0.015	±0.015	±0.01
Reversing backlash [mm]	≤ 0.15		
Position sensing	Via proximity switch		
	Via IO-Link		
With axial motor mounting			
Max. speed ¹⁾ [m/s]	0.18	0.25	0.25
Speed "Speed Press" ²⁾ [m/s]	0.01		
Max. acceleration ²⁾ [m/s ²]	5		
With parallel motor mounting			
Max. speed ¹⁾ [m/s]	0.18	0.235	0.215
Speed "Speed Press" ²⁾ [m/s]	0.01		
Max. acceleration ²⁾ [m/s ²]	3		

1) Rotational speed and speed are stroke-dependent.
Adjustable in increments of 10%

2) Unchangeable parameter

Spindle

Size	32	45	60
Diameter [mm]	8	10	12
Pitch [mm/rev]	8	10	12

Datasheet

Electrical data			
Size		32	45 60
Motor			
Nominal voltage DC	[V]	24 (±15%)	
Nominal current	[A]	3	3 5.3
Max. current consumption (load)	[A]	3	3 5.3
Max. current consumption (logic)	[mA]	300	
Encoder			
Rotor position sensor		Absolute encoder, single turn	
Rotor position sensor measuring principle		Magnetic	
Rotor position encoder resolution	[bit]	16	
Interfaces			
Size		32	45 60
Parameterisation interface			
IO-Link		Yes	
User interface		Yes	
Digital inputs			
Number		2	
Switching logic		PNP	
		NPN	
Characteristics		Not galvanically isolated	
		Configurable	
Specification		Based on IEC 61131-2, type 1	
Operating range	[V]	24	
Digital outputs			
Number		2	
Switching logic		PNP	
		NPN	
Rotor position sensor		Absolute encoder, single turn	
Characteristics		Not galvanically isolated	
		Configurable	
Max. current	[mA]	100	

Datasheet

Technical data – IO-Link				
Size		32	45	60
SIO mode support		Yes		
Communication mode		COM3 (230.4 kBd)		
Connection technology		Plug		
Port class		A		
No. of ports		1		
Process data width OUT	[byte]	2		
Process data content OUT	[bit]	1 (Move in)		
	[bit]	1 (Move out)		
	[bit]	1 (Move Intermediate)		
	[bit]	1 (Quit Error)		
Process data width IN	[byte]	2		
Process data content IN	[bit]	1 (State Device)		
	[bit]	1 (State Move)		
	[bit]	1 (State in)		
	[bit]	1 (State out)		
	[bit]	1 (State Intermediate)		
Service data content IN	[bit]	32 (Force)		
	[bit]	32 (Position)		
	[bit]	32 (Speed)		
Minimum cycle time	[ms]	1		
Data memory required	[kilobyte]	0.5		
Protocol version		Device V 1.1		

Operating and environmental conditions				
Size		32	45	60
Insulation class		B		
Ambient temperature	[°C]	0 ... +50		
Storage temperature	[°C]	-20 ... +60		
Note on ambient temperature		Above an ambient temperature of 30°C, the power must be reduced by 2% per K		
Temperature monitoring		Switch-off for excessive temperature		
		Integrated precise CMOS temperature sensor with analogue output		
Relative humidity	[%]	0 ... 90		
Protection class		III		
Degree of protection		IP40		
Duty cycle	[%]	100		
CE marking (see declaration of conformity)		To EU EMC Directive for EMCS-ST → festo.com/sp		
		To EU RoHS Directive		
UKCA marking (see declaration of conformity)		To UK instructions for EMC		
		To UK RoHS instructions		
KC mark		KC EMC		
Certification		RCM		
Vibration resistance		Transport application test with severity level 1 to FN 942017-4 and EN 61800-2 and EN 61800-5-1		
Shock resistance		Shock test with severity level 1 to FN 942017-5 and EN 61800-2		
Maintenance interval		Lifetime lubrication		

Weight				
Size		32	45	60
With axial motor mounting				
Basic weight at 0 mm stroke	[g]	889	1354	2862
Additional weight per 10 mm stroke	[g]	18	36	51
Moving mass with 0 mm stroke	[g]	83	220	525
With parallel motor mounting				
Basic weight at 0 mm stroke	[g]	1053	1477	3126
Additional weight per 10 mm stroke	[g]	18	36	51
Moving mass with 0 mm stroke	[g]	83	220	525

Datasheet

Materials

Sectional view

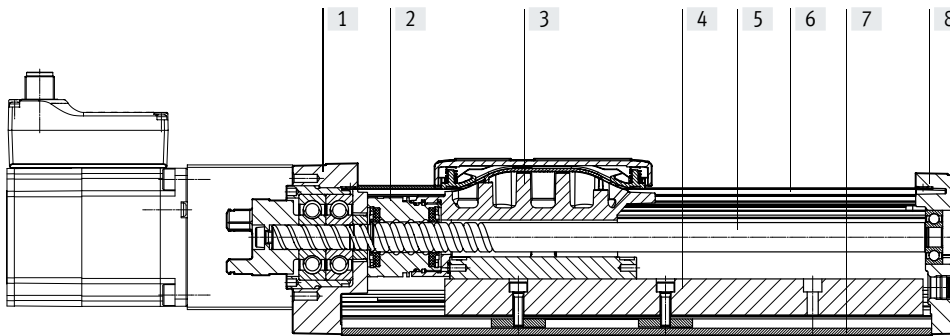

Axis		
[1]	Drive cover	Painted die-cast aluminium
[2]	Spindle nut	Steel
[3]	Slide	Die-cast aluminium
[4]	Guide	Steel
[5]	Spindle	Steel
[6]	Cover strip	High-alloy stainless steel
[7]	Profile	Anodised wrought aluminium alloy
[8]	End cap	Painted die-cast aluminium
	PWIS conformity	VDMA24364 zone III
	Note on materials	RoHS-compliant

Pin allocation

Power supply

Plug
M12x1, 4-pin, T-coded to EN 61076-2-111

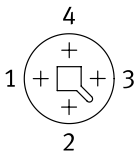

Pin	Function
1	Power voltage supply (24 V DC)
2	Reference potential, power voltage supply (GND)
3	Reserved, do not connect
4	Functional earth (FE)

Logic interface

Plug
M12x1, 8-pin, A-coded to EN 61076-2-101

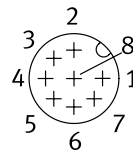

When used with digital I/O	
Pin	Function
1	Logic voltage supply (24 V DC)
2	Digital output 1 (State "In")
3	Digital output 2 (State "Out")
4	Reference potential, logic voltage supply (GND)
5	Digital input 1 (Move "In")
6	Digital input 2 (Move "Out")
7	Reserved, do not connect
8	Reference potential, logic voltage supply (GND)

When used with IO-Link	
Pin	Function
1	L+ IO-Link power supply (24 V DC)
2	Reserved, do not connect
3	C/Q communication with the IO-Link master
4	L – Reference potential, IO-Link power supply (0 V)
5	Reserved, do not connect
6	Reserved, do not connect
7	Reserved, do not connect
8	L – Reference potential, IO-Link power supply (0 V)

Datasheet

Load values

The indicated forces and torques refer to the centre of the guide. The point of application of force is the point where the centre of the guide and the longitudinal centre of the slide intersect. These values must not be exceeded during dynamic operation. Special attention must be paid to the deceleration phase.

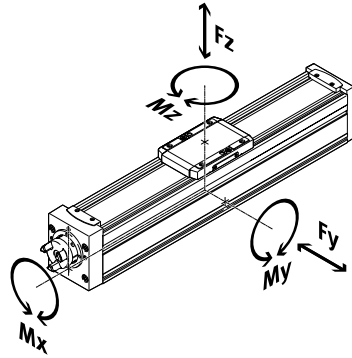

Distance from the slide surface to the centre of the guide

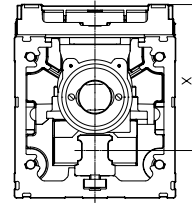

Max. permissible forces and torques on the slide (strength limits)				
Size		32	45	60
F _y _{max.}	[N]	150	300	600
F _z _{max.}	[N]	300	600	1800
M _x _{max.}	[Nm]	1.3	5.5	29.1
M _y _{max.}	[Nm]	1.1	4.7	31.8
M _z _{max.}	[Nm]	1.1	4.7	31.8

Distance from the slide surface to the centre of the guide				
Size		32	45	60
Dimension x	[mm]	31.4	42.8	54.6

Max. permissible forces and torques for the guide calculation, for a service life of 5000 km or 5x 10 ⁶ cycles				
Size		32	45	60
F _y _{max.}	[N]	356	880	3641
F _z _{max.}	[N]	356	880	3641
M _x _{max.}	[Nm]	1.3	5.5	29.1
M _y _{max.}	[Nm]	1.1	4.7	31.8
M _z _{max.}	[Nm]	1.1	4.7	31.8

Note
 For a guide system to have a service life of 5000 km, the load comparison factor must have a value of $f_v \leq 1$, based on the maximum permissible forces and torques for a service life of 5000 km. This formula can be used to calculate a guide value. The engineering software "Electric Motion Sizing" is available for more precise calculations → www.festo.com

If the axis is subjected to two or more of the indicated forces and torques simultaneously, the following equation must be satisfied in addition to the indicated maximum loads:

Calculating the load comparison factor:

$$f_v = \frac{|F_{y1}|}{F_{y2}} + \frac{|F_{z1}|}{F_{z2}} + \frac{|M_{x1}|}{M_{x2}} + \frac{|M_{y1}|}{M_{y2}} + \frac{|M_{z1}|}{M_{z2}} \leq 1$$

F₁/M₁ = dynamic value

F₂/M₂ = maximum value

Datasheet

Calculating the service life

The service life of the guide depends on the load. To be able to make a statement as to the service life of the guide, the graph below plots the load comparison factor f_v against the service life.

These values are only theoretical. You must consult your local Festo contact for a load comparison factor f_v greater than 1.

Load comparison factor f_v as a function of service life l

Example:

A user wants to move an x kg load. Using the formula (→ page 14) gives a value of 1.5 for the load comparison factor f_v . According to the graph, the guide would have a service life of approx. 1 500 km. Reducing the acceleration reduces the M_y and M_z values. A load comparison factor f_v of 1 now gives a service life of 5000 km.

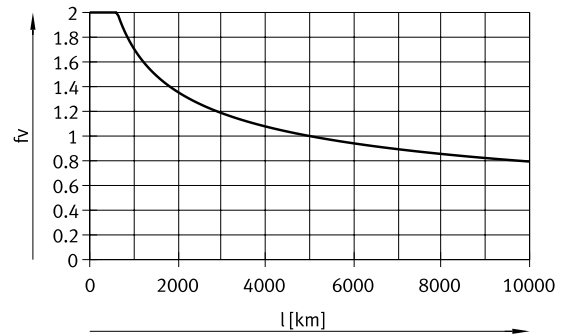

Comparison of the characteristic load values for 5000 km with dynamic forces and torques of recirculating ball bearing guides

The characteristic load values of the bearing guides are standardised to ISO and JIS using dynamic and static forces and torques. These forces and torques are based on an expected service life of the guide system of 100 km to ISO or 50 km to JIS.

As the characteristic load values are dependent on the service life, the maximum permissible forces and torques for a 5000 km service life cannot be compared with the dynamic forces and torques of bearing guides to ISO/JIS.

To make it easier to compare the guide capacity of linear axes ELGS with bearing guides, the table below lists the theoretically permissible forces and torques for a calculated service life of 100 km. This corresponds to the dynamic forces and torques to ISO.

These 100 km values have been calculated mathematically and are only to be used for comparing with dynamic forces and torques to ISO. The drives must not be loaded with these characteristic values as this could damage the axes.

Max. permissible forces and torques for a theoretical service life of 100 km (from a guide perspective only)

Size		32	45	60
$F_{y_{max}}$	[N]	1310	3240	13400
$F_{z_{max}}$	[N]	1310	3240	13400
$M_{x_{max}}$	[Nm]	5	20	107
$M_{y_{max}}$	[Nm]	4	17	117
$M_{z_{max}}$	[Nm]	4	17	117

Service life of the motor

The service life of the motor at nominal power is 20000 h.

Datasheet

Sizing example

Application data:

- Payload: 8 kg
- Mounting position: horizontal
- Motor mounting position: axial
- Stroke: 400 mm
- Max. permissible positioning time: 4 s (one direction)

Step 1: Selecting the possible size from the table → page 10

Mechanical data				
Size		32	45	60
Max. payload				
Horizontal	[kg]	2	10	20
Vertical	[kg]	2	5	13

→ Smallest possible size: ELGS-BS-KF-45

Step 2: Selecting the max. speed level v for payload m

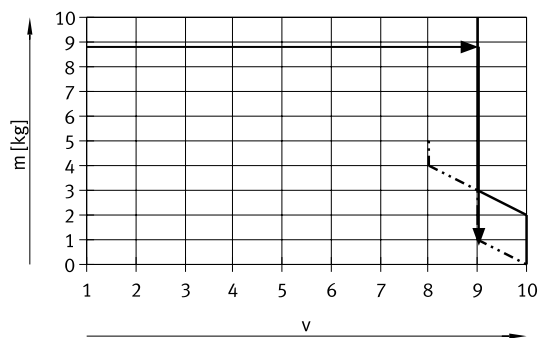

- Horizontal
- - - Vertical

→ Max. speed level for payload: level 9

Step 3: Reading off the min. positioning time t for stroke l

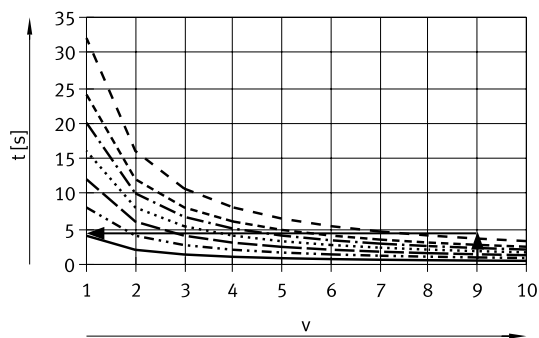

- l = 100 mm
- - - l = 200 mm
- - - l = 300 mm
- l = 400 mm
- · - · l = 500 mm
- - - l = 600 mm
- - - l = 800 mm

→ Min. positioning time for 400 mm at level 9: 2 s

Result

The application can be implemented using ELGS-BS-KF-45-400. A minimum positioning time (one direction) of 2 s is achieved. Longer positioning times can be selected at any time using a lower speed level.

Datasheet

Mass m as a function of speed level v

With axial kit

Size 32

Size 45

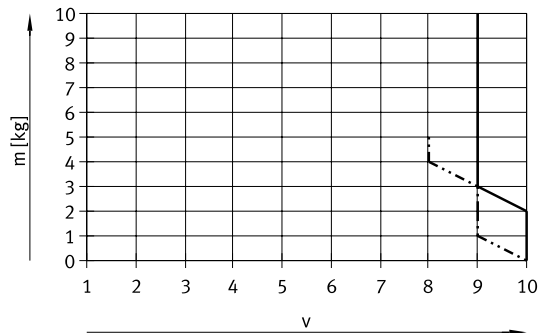
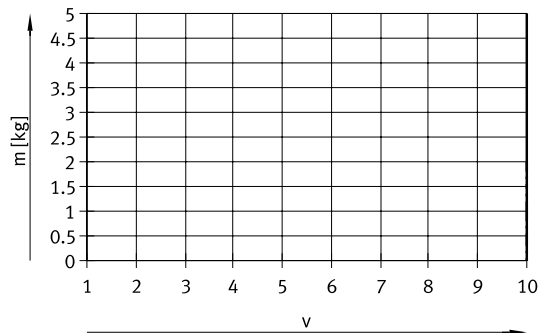

Size 60

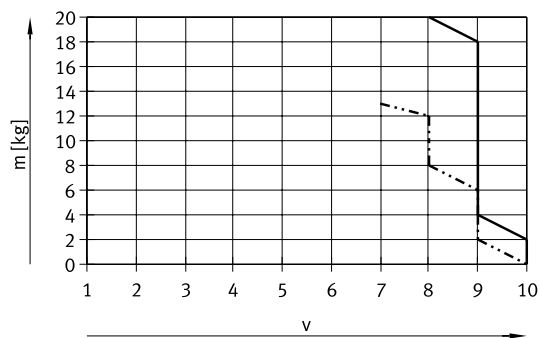

Note:

The lines represent the maximum values. The lower speed levels can be set at any time.

— Horizontal
 - - - - - Vertical

Datasheet

Positioning time t as a function of speed level v and stroke l

With axial kit

Size 32

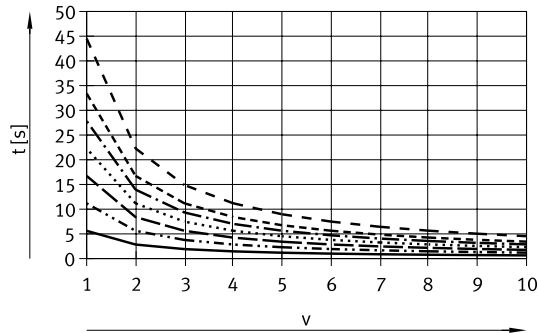

- $l = 100$ mm
- · - · - $l = 200$ mm
- - - $l = 300$ mm
- · · · · $l = 400$ mm
- · - · - $l = 500$ mm
- - - $l = 600$ mm
- - - $l = 800$ mm

Size 45

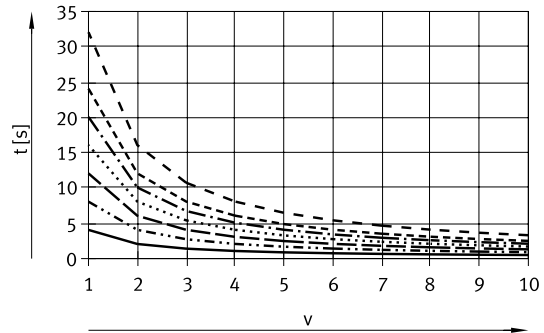

- $l = 100$ mm
- · - · - $l = 200$ mm
- - - $l = 300$ mm
- · · · · $l = 400$ mm
- · - · - $l = 500$ mm
- - - $l = 600$ mm
- - - $l = 800$ mm

Positioning time t as a function of speed level v and stroke l

Size 60

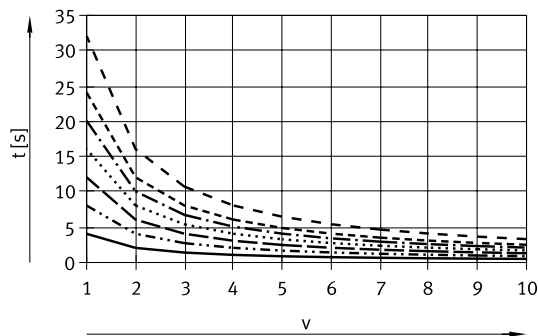

- $l = 100$ mm
- · - · - $l = 200$ mm
- - - $l = 300$ mm
- · · · · $l = 400$ mm
- · - · - $l = 500$ mm
- - - $l = 600$ mm
- - - $l = 800$ mm

Datasheet

Mass m as a function of speed level v

With parallel kit

Size 32

Size 45

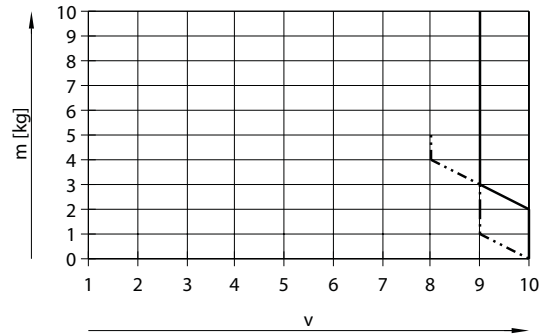
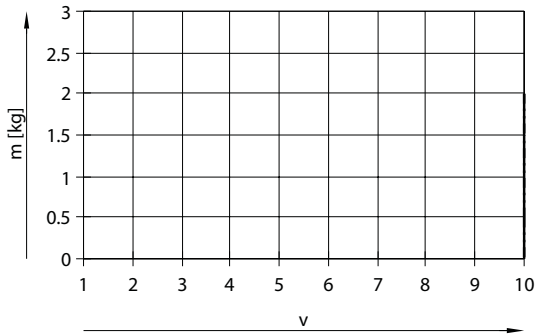

Size 60

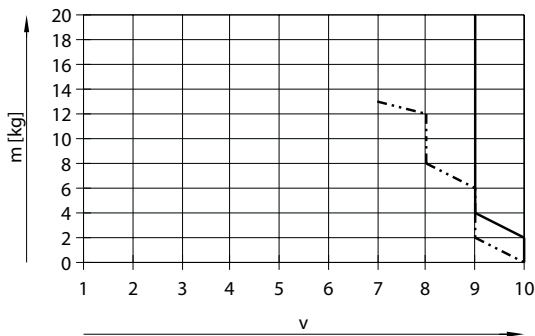

Note:

The lines represent the maximum values. The lower speed levels can be set at any time.

— Horizontal
 - - - - - Vertical

Datasheet

Positioning time t as a function of speed level v and stroke l

With parallel kit

Size 32

Size 45

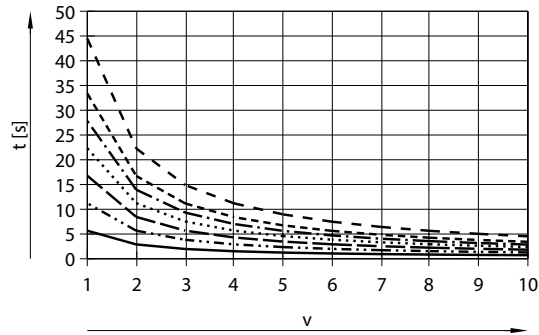

- $l = 100$ mm
- $l = 200$ mm
- - - $l = 300$ mm
- · - · $l = 400$ mm
- · - - $l = 500$ mm
- - - - $l = 600$ mm
- - - - $l = 800$ mm

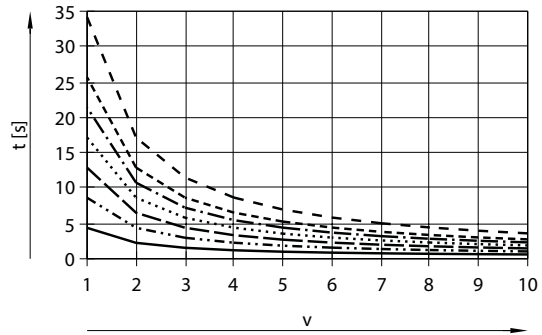

- $l = 100$ mm
- $l = 200$ mm
- - - $l = 300$ mm
- · - · $l = 400$ mm
- · - - $l = 500$ mm
- - - - $l = 600$ mm
- - - - $l = 800$ mm

Positioning time t as a function of speed level v and stroke l

Size 60

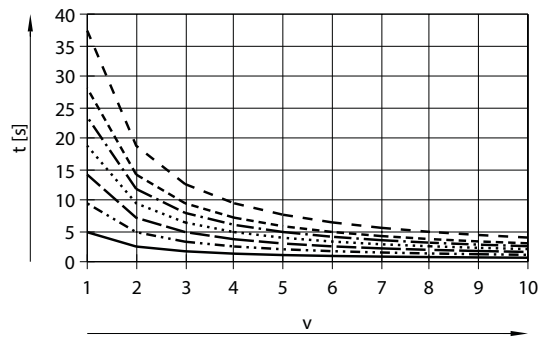

- $l = 100$ mm
- $l = 200$ mm
- - - $l = 300$ mm
- · - · $l = 400$ mm
- · - - $l = 500$ mm
- - - - $l = 600$ mm
- - - - $l = 800$ mm

Datasheet

Feed force F as a function of force level F1

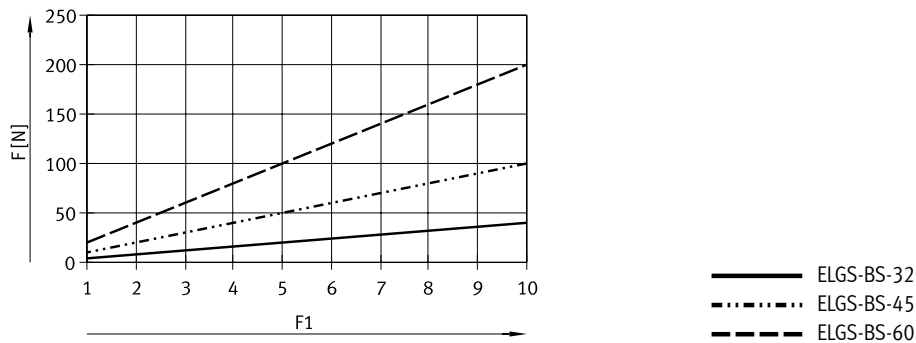

Feed force F as a function of service life l

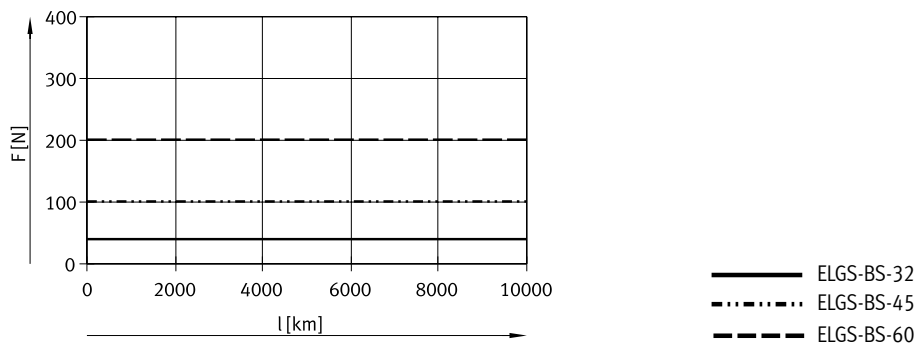

2nd moments of area

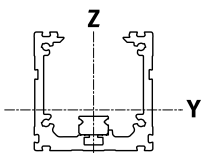

Size		32	45	60
ly	[mm ⁴]	38x10 ³	140x10 ³	441x10 ³
lz	[mm ⁴]	45x10 ³	170x10 ³	542x10 ³

Recommended deflection limits

Adherence to the following deflection limits is recommended so as not to impair the functionality of the axes. Greater deformation can result in increased friction, greater wear and reduced service life.

Size	Dynamic deflection (moving load)	Static deflection (stationary load)
32 ... 60	0.05% of the axis length, max. 0.5 mm	0.1% of the axis length

Datasheet

Dimensions – With axial motor mounting

Download CAD data → www.festo.com

Size 32/45/60

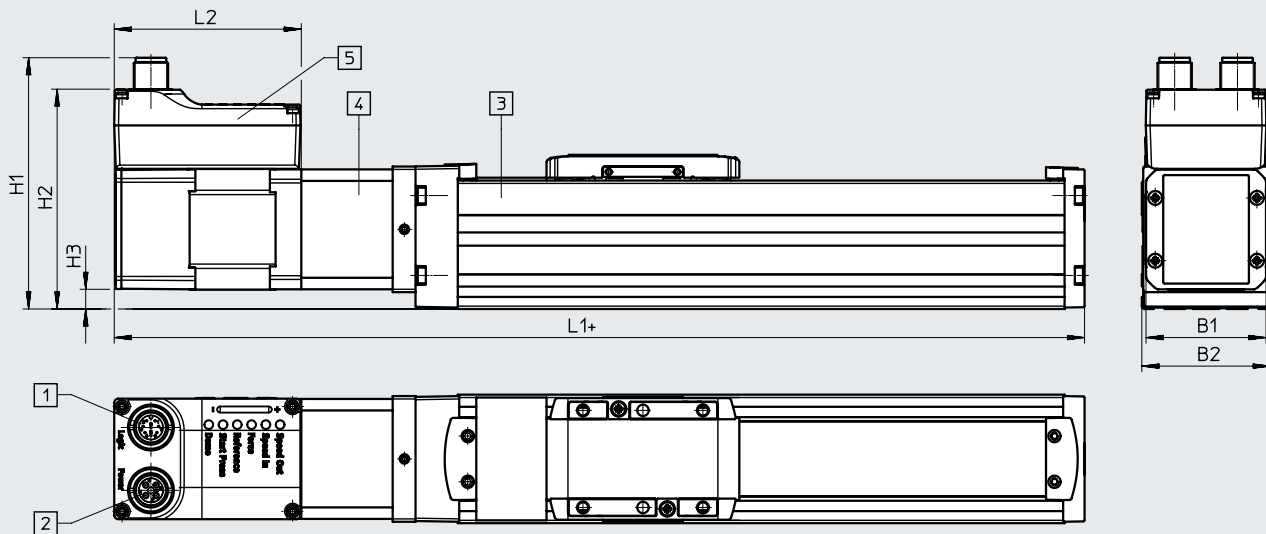

- [1] Connection to logic interface
- [2] Connection to power supply
- [3] Axis
- [4] Axial kit
- [5] Motor
- + = plus stroke length

Size	B1	B2	H1	H2	H3	L1	L2
32	42.3	32	81.2	70	1.2	209.5	65
45	42.3	45	88	76.8	6.8	239.3	65
60	56.6	60	107.3	96.1	10.5	287	73.5

Datasheet

Dimensions – With parallel motor mounting

Download CAD data → www.festo.com

Size 32/45/60

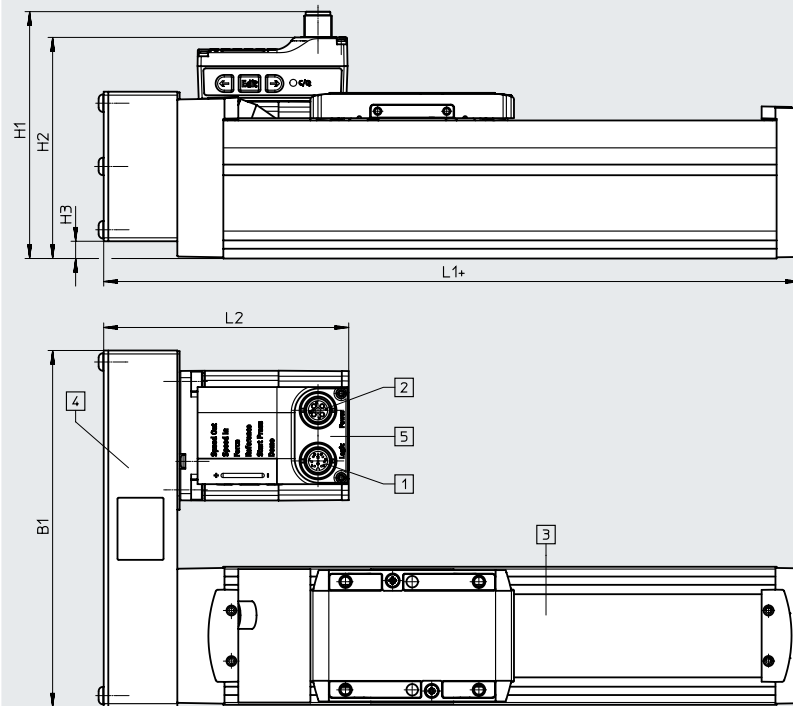

- [1] Connection to logic interface
- [2] Connection to power supply
- [3] Axis
- [4] Parallel kit
- [5] Motor
- + = plus stroke length

Dimensions for other motor mounting variants → CAD data.

Size	B1	H1	H2	H3	L1	L2
32	111	80	69	-2.5	128.5	93
45	111	88	76	5.4	158.3	93
60	155	107	96	7.5	202.5	106.5

Datasheet

Dimensions

Download CAD data → www.festo.com

↓ A → Page 26

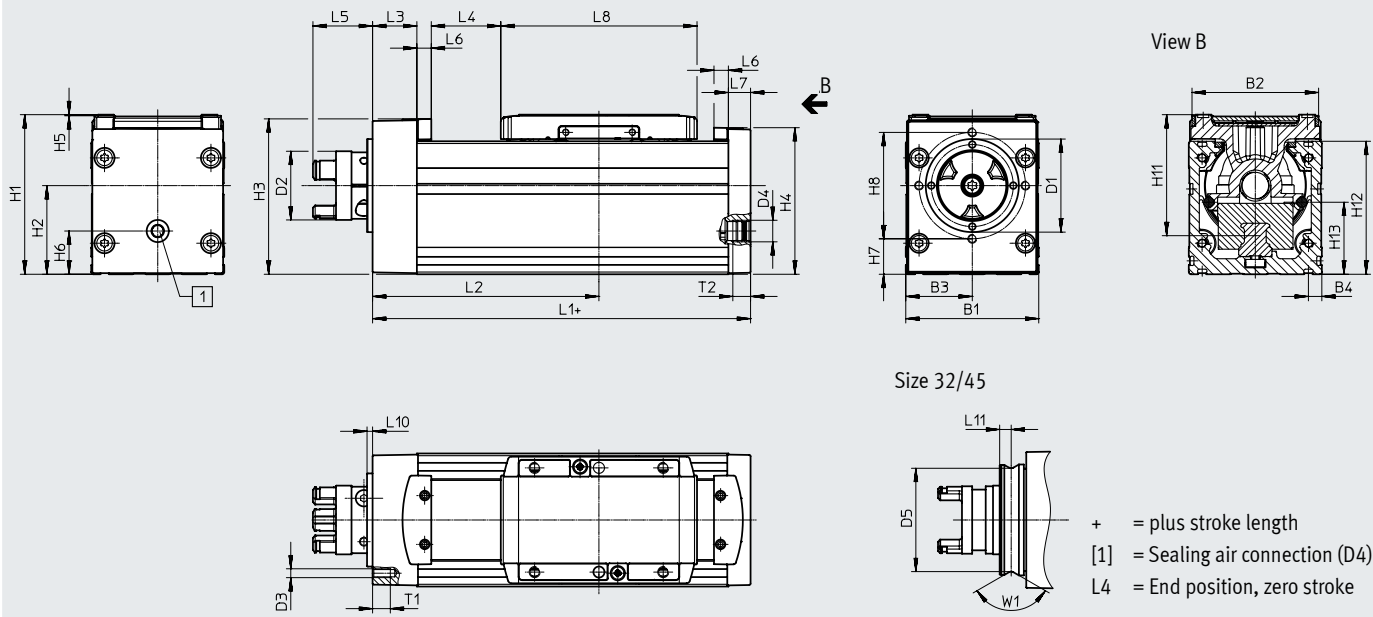

Size	B1	B2	B3	B4	D1 ∅	D2 ∅	D3	D4	D5 ∅	H1	H2
32	32	29.6	16	4.9	25	16.5	-	M5	23	38.5	20
45	45	42.6	22.5	6.1	32	16.5	-	G1/8	29.6	54	27.9
60	60	57.1	30	6.1	42	31	M4	G1/8	-	72	40

Size	H3	H4	H5	H6	H7	H8	H11	H12	H13	L1	L2 min.
32	36.3	35.6	0.3	8	-	-	31.4	32	13.7	104.5	57.9
45	50.8	49.6	0.5	12.5	-	-	42.8	45	18.5	134.3	79.7
60	70.1	66.1	0.5	19.5	16	48	54.6	60	32.5	170.5	102.1

Size	L3	L4	L5	L6	L7	L8	L10	L11	T1	T2	W1
32	10.5	13.4	19.9	4.5	5	59	6	2.6	-	5.5	120°
45	14.8	24.6	19.9	6.5	7	67.5	6	2.9	-	8	90°
60	20	31.4	26.9	6.5	10	88.5	2.5	-	8	8	-

Datasheet

Dimensions

Download CAD data → www.festo.com

Profile

Size 32

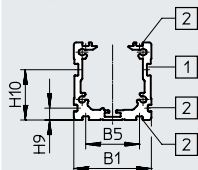

Size 45

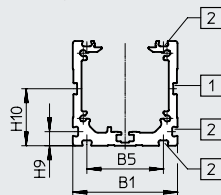

Size 60

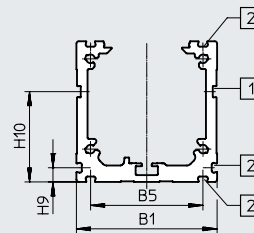

- [1] = Slot for sensor bracket
- [2] = Mounting slot

Size	B1	B5	H9	H10
32	32	22.2	4.9	20.8
45	45	32.9	6.1	24.5
60	60	47.9	6.1	38.5

Datasheet

Dimensions

Download CAD data → www.festo.com

Slide
Size 32

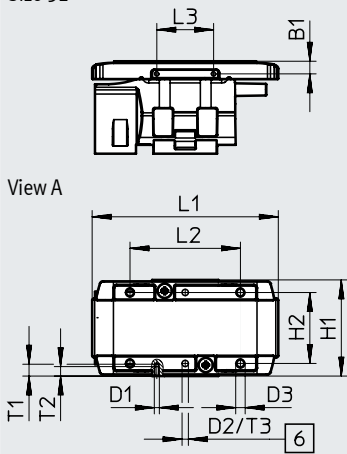

View A

Size 45

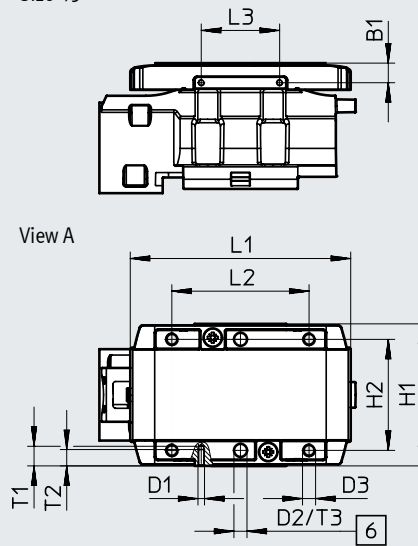

View A

[6] Drilled hole for centring pin ZBS

Size	B1	D1	D2 ∅ H8	D3	H1	H2 ±0.1 For D2 ±0.03
32	±0.1 4	M1.6	2	M3	±0.1 30.5	22.5
45	6	M2	4	M4	43.5	34

Size	L1	L2	L3	T1	T2	T3	T4 ¹⁾
		±0.1	±0.1			+0.1	
32	59	35	18	3.8	3	3.1	4 ... 5
45	67.5	42	24	6	5	3.1	6 ... 7.5

1) Recommended screw-in depth

Datasheet

Dimensions

Download CAD data → www.festo.com

Slide

Size 60

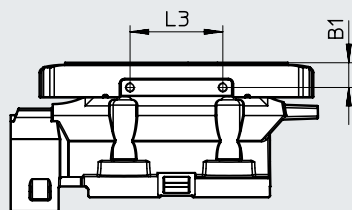

View A

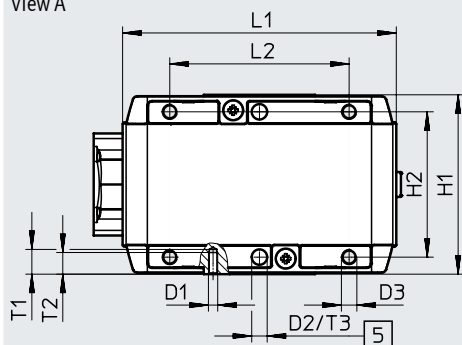

[5] Drilled hole for centring pin ZBH

Size	B1	D1	D2 ∅ H8	D3	H1	H2 ±0.1 For D2 ±0.03
60	±0.1 8	M3	5	M5	±0.1 58	47

Size	L1	L2	L3	T1	T2	T3	T4 ¹⁾
60	88.5	±0.1 58	±0.1 30	9	7	+0.1 1.3	8.5 ... 10

1) Recommended screw-in depth

Datasheet

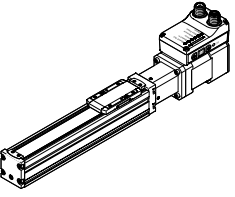
Ordering data	Size	Spindle pitch	Stroke	Part no.	Type
	32	8	100	8083424	ELGS-BS-KF-32-100-8P-ST-M-H1-PLK-AA
			200	8083425	ELGS-BS-KF-32-200-8P-ST-M-H1-PLK-AA
			300	8083426	ELGS-BS-KF-32-300-8P-ST-M-H1-PLK-AA
			400	8083427	ELGS-BS-KF-32-400-8P-ST-M-H1-PLK-AA
			500	8083428	ELGS-BS-KF-32-500-8P-ST-M-H1-PLK-AA
			600	8083429	ELGS-BS-KF-32-600-8P-ST-M-H1-PLK-AA
			800	8083430	ELGS-BS-KF-32-800-8P-ST-M-H1-PLK-AA
	45	10	100	8083470	ELGS-BS-KF-45-100-10P-ST-M-H1-PLK-AA
			200	8083471	ELGS-BS-KF-45-200-10P-ST-M-H1-PLK-AA
			300	8083472	ELGS-BS-KF-45-300-10P-ST-M-H1-PLK-AA
			400	8083473	ELGS-BS-KF-45-400-10P-ST-M-H1-PLK-AA
			500	8083474	ELGS-BS-KF-45-500-10P-ST-M-H1-PLK-AA
			600	8083475	ELGS-BS-KF-45-600-10P-ST-M-H1-PLK-AA
			800	8083476	ELGS-BS-KF-45-800-10P-ST-M-H1-PLK-AA
	60	12	100	8083383	ELGS-BS-KF-60-100-12P-ST-M-H1-PLK-AA
			200	8083384	ELGS-BS-KF-60-200-12P-ST-M-H1-PLK-AA
			300	8083385	ELGS-BS-KF-60-300-12P-ST-M-H1-PLK-AA
			400	8083386	ELGS-BS-KF-60-400-12P-ST-M-H1-PLK-AA
			500	8083387	ELGS-BS-KF-60-500-12P-ST-M-H1-PLK-AA
			600	8083388	ELGS-BS-KF-60-600-12P-ST-M-H1-PLK-AA
			800	8083389	ELGS-BS-KF-60-800-12P-ST-M-H1-PLK-AA

Ordering data – Modular product system

Ordering table						
Size	32	45	60	Conditions	Code	Enter code
Module no.	8083433	8083493	8083398			
Series	ELGS				ELGS	ELGS
Drive system	Ball screw				-BS	-BS
Guide	Recirculating ball bearing guide				-KF	-KF
Size	32	45	60		-...	
Stroke [mm]	100, 200, 300, 400, 500, 600, 800	100, 200, 300, 400, 500, 600, 800	100, 200, 300, 400, 500, 600, 800		-...	
Spindle pitch [mm]	8P	10P	12P		-...	
Motor type	Stepper motor ST				-ST	-ST
Controller	Integrated				-M	-M
Operator panel	Integrated				-H1	-H1
Bus protocol/control	NPN and IO-Link				-NLK	
	PNP and IO-Link				-PLK	
End-position sensing	With integrated end-position sensing				-AA	-AA
Cable outlet direction	Standard			[1]		
	Underneath			[2]	-D	
	Rear			[2]	-B	
	Front			[3]	-F	
Motor attachment position	Axial (standard)					
	Parallel, rear			[4]	-PB	
	Parallel, front			[5]	-PF	
	Parallel, underneath			[6]	-PD	
Electrical accessories	None					
	Adapter for operation as IO device				+L1	
Operating instructions	With operating instructions					
	Without operating instructions				DN	

[1] Not with motor mounting position PB; PD

[2] Not with motor mounting position PF

[3] Not with motor mounting position PB

[4] Not in combination with cable outlet direction standard or F

[5] Not in combination with cable outlet direction B; D

[6] Only in combination with cable outlet direction standard

Accessories

Profile mounting EAHF-L2-...-P-S

Material:

Anodised wrought aluminium alloy

RoHS-compliant

- For mounting the axis on the side of the profile

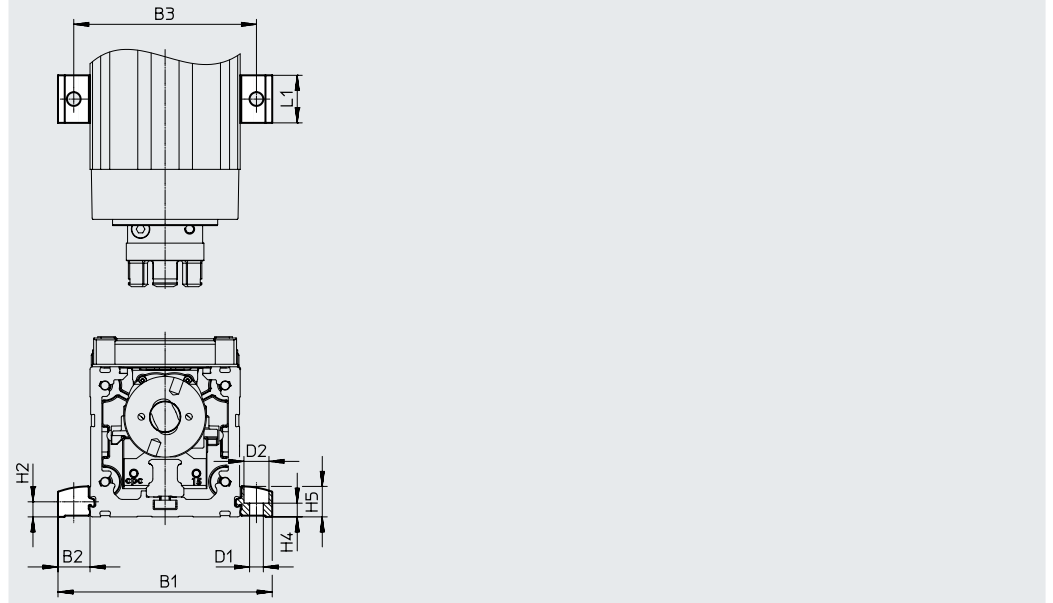
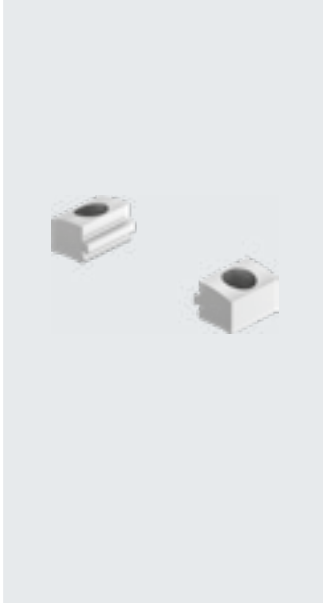

Dimensions and ordering data

For size	B1	B2	B3	D1 ∅ H13	D2 ∅ H13	H2
32	51.4	9.7	42	4.5	8	4.9
45	70.6	12.8	58	5.5	10	6.1
60	85.6	12.8	73	5.5	10	6.1

For size	H4 ±0.1	H5	L1	Weight [g]	Part no.	Type
32	4.2	9	19	4	5183153	EAHF-L2-25-P-S
45	5.5	12.2	19	6	5184133	EAHF-L2-45-P-S
60	5.5	12.2	19	6	5184133	EAHF-L2-45-P-S

Accessories

Profile mounting EAHF-L2-...-P

Material:

Anodised wrought aluminium alloy

RoHS-compliant

- For mounting the axis on the side of the profile.

The profile mounting can be attached to the mounting surface using the drilled hole in the centre.

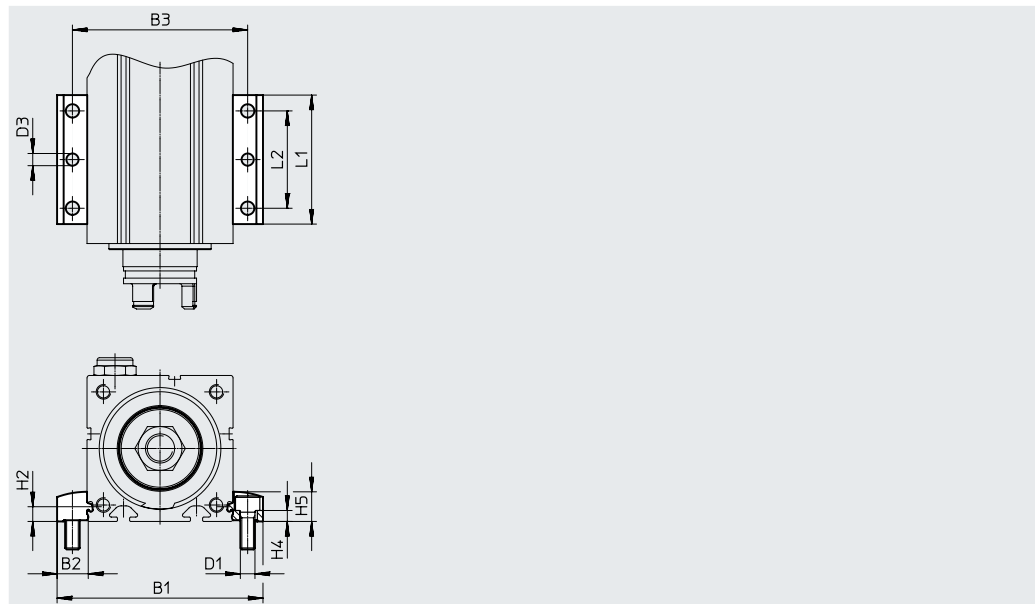

Dimensions and ordering data

For size	B1	B2	B3	D1 ∅ H13	D2 ∅ H13	D3 ∅	H2
32	51.4	9.7	42	4.5	8	4	4.9
45	70.6	12.8	58	5.5	10	5	6.1
60	85.6	12.8	73	5.5	10	5	6.1

For size	H4 ±0.1	H5	L1	L2	Weight [g]	Part no.	Type
32	4.2	9	53	40	19	4835684	EAHF-L2-25-P
45	5.5	12.2	53	40	35	4835728	EAHF-L2-45-P
60	5.5	12.2	53	40	35	4835728	EAHF-L2-45-P

Accessories

Profile mounting EAHF-L2-...-P-D...

Material:

Anodised wrought aluminium alloy

RoHS-compliant

- For axis/axis mounting without adapter plate
- Mounting option: base axis with one-size-down assembly axis (→ page 4)

Combination matrix

[1] Base axis ELGC-BS/-TB; ELFC	Size	[2] Assembly axis ELGC-BS/-TB; ELFC; EGSC-BS			
		25	32	45	60
	32	4759753	-	-	-
	45	-	4759748	-	-
	60	-	-	4759739	-

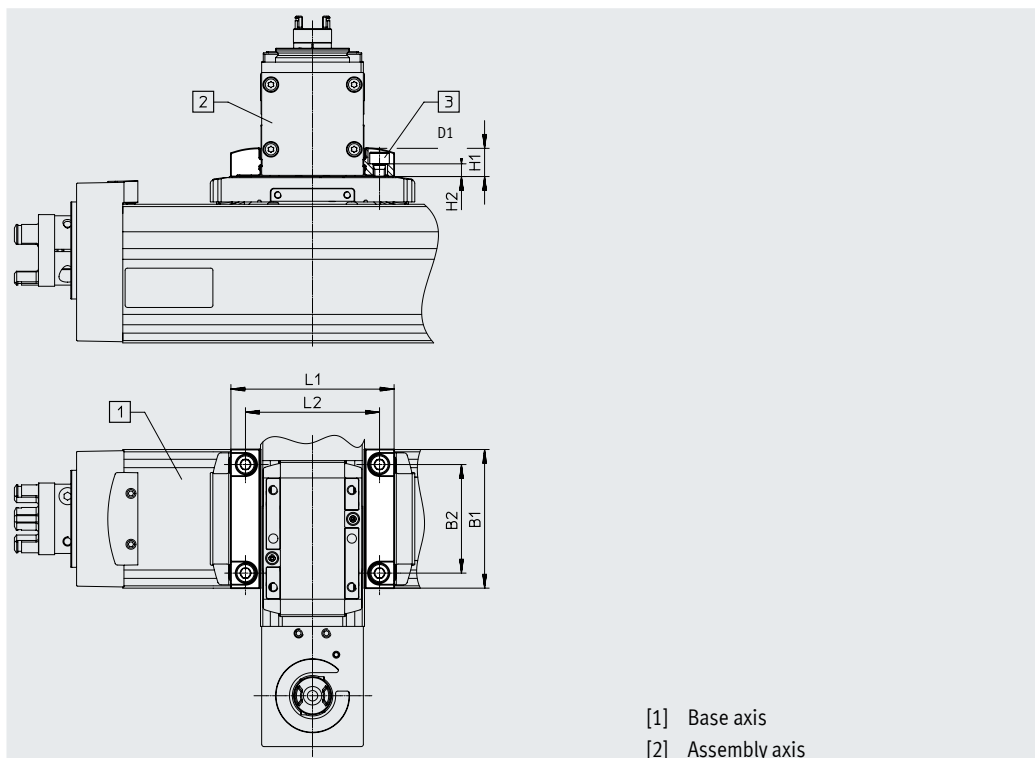

[1] Base axis
[2] Assembly axis

Dimensions and ordering data

For combination (size)	B1	B2	D1	H1
45/32	45	34	M4	9
60/45	60	47	M5	12.2

For combination (size)	H2 ±0.1	L1	L2	Weight [g]	Part no.	Type
45/32	3.7	51.4	42	24	4759748	EAHF-L2-25-P-D2
60/45	5.5	70.6	58	56	4759739	EAHF-L2-45-P-D3

Accessories

Adapter kit EHAA-D-L2

Material:

Anodised wrought aluminium alloy

RoHS-compliant

- For axis/axis mounting with adapter plate
- Mounting option: base axis with same size or one-size-down assembly axis (→ page 4)

Combination matrix		[2] Assembly axis ELGC-BS/-TB; ELFC; EGSC-BS				
	Size	25	32	45	60	80
[1] Base axis ELGC-BS/-TB; ELFC	32	8066713		-	-	-
	45	-	8066714		-	-
	60	-	-	8066715		-

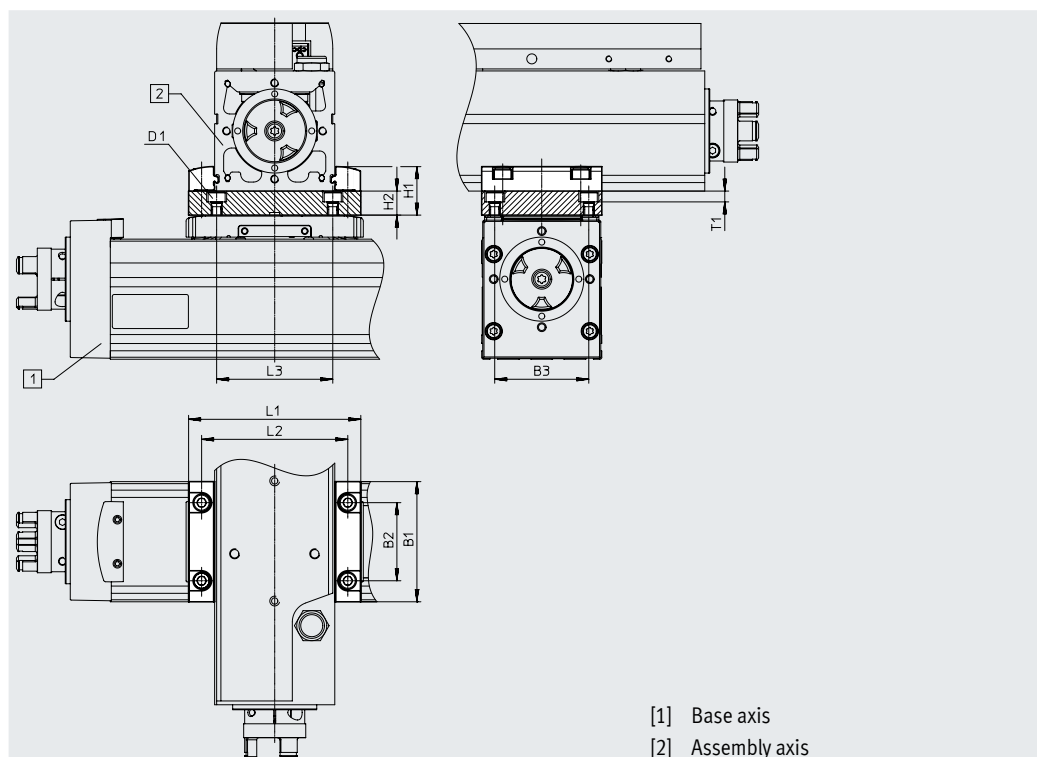

[1] Base axis
[2] Assembly axis

Dimensions and ordering data												
For combination (size)	B1	B3 ±0.05	D1	H1	H2	L1	L2	L3	T1	Weight [g]	Part no.	Type
45/32	45	34	M4	19	10	51.4	42	42	5.4	136	8066714	EHAA-D-L2-45-L2-45
60/45	60	47	M5	24.2	12	70.6	58	58	5.4	205	8066715	EHAA-D-L2-60-L2-60

For combination (size)	B1	B2	B3 ±0.05	D1	H1	H2	L1	L2	L3	T1	Weight [g]	Part no.	Type
45/45	45	32	34	M4	22.2	10	71	58	42	5.4	136	8066714	EHAA-D-L2-45-L2-45
60/60	60	39	47	M5	24.2	12	86	73	58	5.4	205	8066715	EHAA-D-L2-60-L2-60

Accessories

Angle kit EHAA-D-L2-...-AP

Material:

Anodised wrought aluminium alloy

RoHS-compliant

- For mounting one-size-down vertical axes (assembly axes) on base axes with mounting position "slide at top" (→ page 4)

Combination matrix

		[2] Assembly axis ELGC-BS/-TB; ELFC; EGSC-BS			
Size		25	32	45	60
[1] Base axis ELGC-BS/-TB; ELFC	32	8066717	-	-	-
	45	-	8066718	-	-
	60	-	-	8066719	-

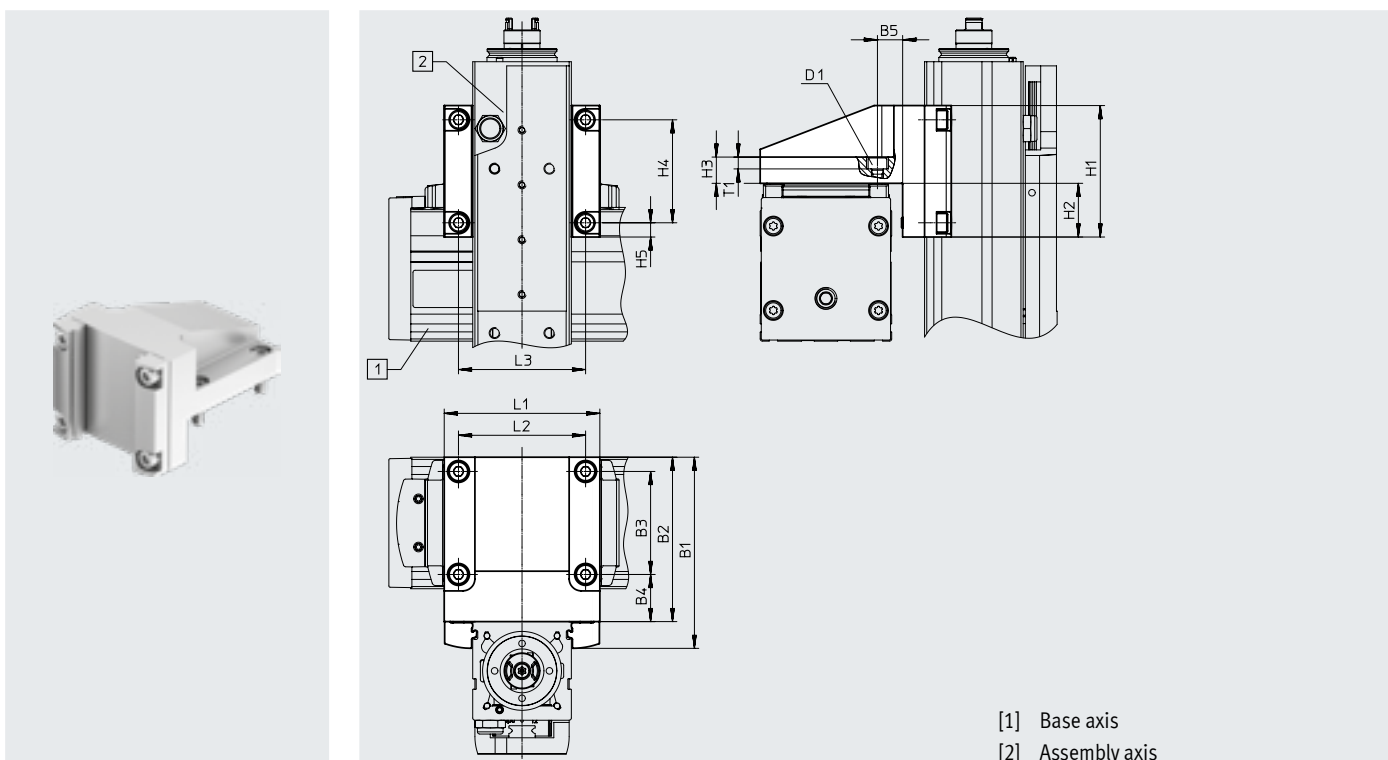

Dimensions and ordering data

For combination (size)	B1	B2	B3	B4	B5	D1	H1	H2	H3	H4
45/32	69	60	34	20.5	11.5	M4	45	17.5	10	34
60/45	87.2	75	47	21.5	11.5	M5	60	24.5	12	47

For combination (size)	H5	L1	L2	L3	T1	Weight [g]	Part no.	Type
45/32	5.5	52	42	42	5.4	222	8066718	EHAA-D-L2-45-L2-32-AP
60/45	6.5	71	58	58	5.4	433	8066719	EHAA-D-L2-60-L2-45-AP

Accessories

Switch lug EAPM-L2-SLS

For sensing using inductive proximity switches SIES-8M

Material:
Galvanised steel
RoHS-compliant

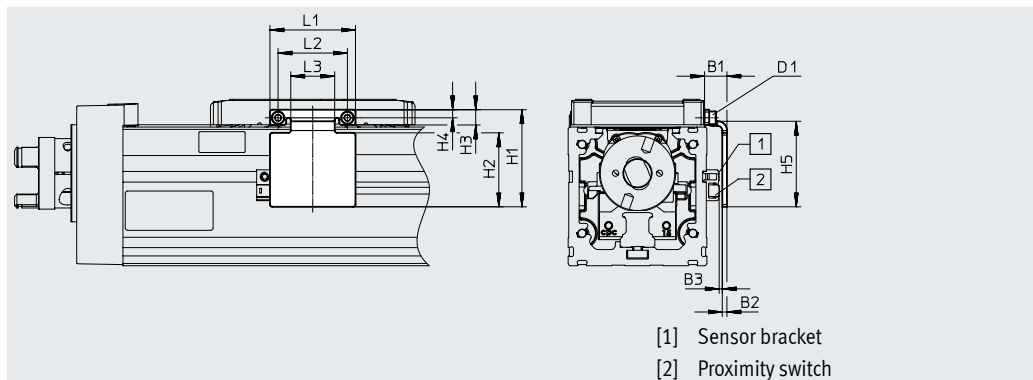
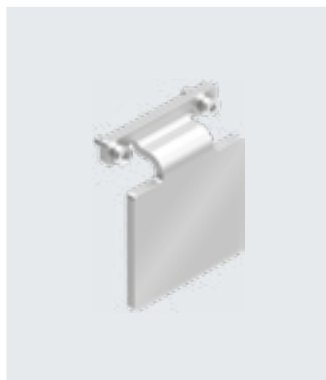

Dimensions and ordering data								
For size	B1	B2	B3	D1	H1 ±0.2	H2	H3	H4
32	9.2	2	1.0±0.31	M1.6	27	19	4.3	2.5
45	9.4	2	1.2±0.31	M2	37	28	5.5	3.3
60	9.7	2	1.3±0.31	M3	37	32	6.6	3.5

For size	H5 ±0.2	L1 ±0.2	L2 ±0.15	L3	Weight [g]	Part no.	Type
32	24	22	18	10	10	8067259	EAPM-L2-32-SLS
45	33	30	24	14	18	8067260	EAPM-L2-45-SLS
60	37	42	30	19	27	8067261	EAPM-L2-60-SLS

Sensor bracket EAPM-L2-SH

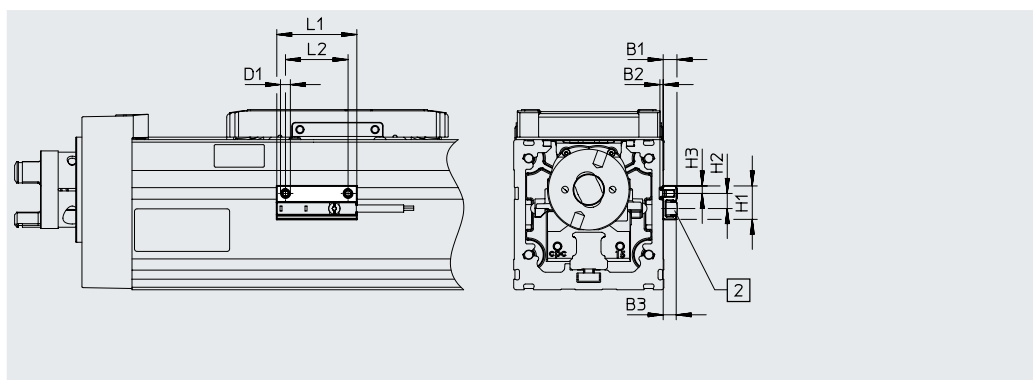

Material:
Anodised wrought aluminium alloy
RoHS-compliant



Dimensions and ordering data						
For size	B1	B2	D1	H1	H2	H3
32, 45, 60	5.5	1.3	M4	13.4	6	3

For size	H3	L1	L2	Weight [g]	Part no.	Type
32, 45, 60	3	32	25	4	4759852	EAPM-L2-SH



Accessories

Ordering data		For size	Description	Part no.	Type	PU ¹⁾
Centring pin ZBS/centring sleeve ZBH						
	32	For slide		525273	ZBS-2	10
	45			562959	ZBS-4	
	60			8146543	ZBH-5-B	
Clamping element EADT						
	32, 45	Tool for retensioning the cover strip		8065818	EADT-S-L5-32	1
	60			8058451	EADT-S-L5-70	
Push-in fitting						
	32	for sealing air connection		133003	QSM-M5-3-I-R	10
	45, 60			133004	QSM-M5-4-I-R	
				186266	QSM-G1/8-4-I	
				186267	QSM-G1/8-6-I	

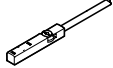
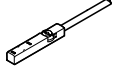
1) Packaging unit

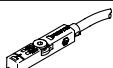
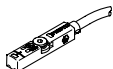
Ordering data – Proximity switches for T-slot, inductive		Switching output	Electrical connection	Cable length [m]	Part no.	Type	Datasheets → Internet: sies
N/O							
	Inserted in the slot from above, flush with the cylinder profile	PNP	Cable, 3-wire	7.5	551386	SIES-8M-PS-24V-K-7.5-OE	
			Plug M8x1, 3-pin	0.3	551387	SIES-8M-PS-24V-K-0.3-M8D	
		NPN	Cable, 3-wire	7.5	551396	SIES-8M-NS-24V-K-7.5-OE	
			Plug M8x1, 3-pin	0.3	551397	SIES-8M-NS-24V-K-0.3-M8D	
N/C							
	Inserted in the slot from above, flush with the cylinder profile	PNP	Cable, 3-wire	7.5	551391	SIES-8M-PO-24V-K-7.5-OE	
			Plug M8x1, 3-pin	0.3	551392	SIES-8M-PO-24V-K-0.3-M8D	
		NPN	Cable, 3-wire	7.5	551401	SIES-8M-NO-24V-K-7.5-OE	
			Plug M8x1, 3-pin	0.3	551402	SIES-8M-NO-24V-K-0.3-M8D	



Ordering data – Proximity switch for T-slot, magneto-resistive		Switching output	Electrical connection	Cable length [m]	Part no.	Type	Datasheets → Internet: smt
N/O							
	Inserted in the slot from above, flush with the cylinder profile, short design	PNP	Cable, 3-wire	2.5	574335	SMT-8M-A-PS-24V-E-2.5-OE	
			Plug M8x1, 3-pin	0.3	574334	SMT-8M-A-PS-24V-E-0.3-M8D	
N/C							
	Inserted in the slot from above, flush with the cylinder profile, short design	PNP	Cable, 3-wire	7.5	574340	SMT-8M-A-PO-24V-E-7.5-OE	

Ordering data – Connecting cables		Electrical connection, left	Electrical connection, right	Cable length [m]	Part no.	Type	Datasheets → Internet: nebu
	Straight socket, M8x1, 3-pin		Cable, open end, 3-wire	2.5	541333	NEBU-M8G3-K-2.5-LE3	
				5	541334	NEBU-M8G3-K-5-LE3	
	Angled socket, M8x1, 3-pin		Cable, open end, 3-wire	2.5	541338	NEBU-M8W3-K-2.5-LE3	
				5	541341	NEBU-M8W3-K-5-LE3	

 **Note**
Proximity switches are optional and only required in order to sense any intermediate positions.

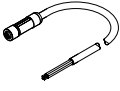
Accessories

Ordering data – Supply cables					Datasheets → Internet: nebl
	Electrical connection, left	Electrical connection, right	Cable length [m]	Part no.	Type
	Angled socket, M12x1, 4-pin	Cable, open end, 4-wire	2	8080778	NEBL-T12W4-E-2-N-LE4
			5	8080779	NEBL-T12W4-E-5-N-LE4
			10	8080780	NEBL-T12W4-E-10-N-LE4
			15	8080781	NEBL-T12W4-E-15-N-LE4
	Straight socket, M12x1, 4-pin	Cable, open end, 4-wire	2	8080790	NEBL-T12G4-E-2-N-LE4
			5	8080791	NEBL-T12G4-E-5-N-LE4
			10	8080792	NEBL-T12G4-E-10-N-LE4
			15	8080793	NEBL-T12G4-E-15-N-LE4

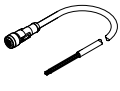
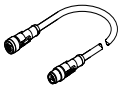
Ordering data – Connecting cables					Datasheets → Internet: nebc
	Electrical connection, left	Electrical connection, right	Cable length [m]	Part no.	Type
	Angled socket, M12x1, 8-pin	Cable, open end, 8-wire	2	8094476	NEBC-M12W8-E-2-N-B-LE8
			5	8094478	NEBC-M12W8-E-5-N-B-LE8
			10	8094481	NEBC-M12W8-E-10-N-B-LE8
			15	8094479	NEBC-M12W8-E-15-N-B-LE8
	Straight plug, M12x1, 8-pin	Cable, open end, 8-wire	2	8080786	NEBC-M12W8-E-2-N-M12G8
			5	8080787	NEBC-M12W8-E-5-N-M12G8
			10	8080788	NEBC-M12W8-E-10-N-M12G8
			15	8080789	NEBC-M12W8-E-15-N-M12G8
	Straight socket, M12x1, 8-pin	Cable, open end, 8-wire	2	8094480	NEBC-M12G8-E-2-N-B-LE8
			5	8094477	NEBC-M12G8-E-5-N-B-LE8
			10	8094482	NEBC-M12G8-E-10-N-B-LE8
			15	8094475	NEBC-M12G8-E-15-N-B-LE8
	Straight plug, M12x1, 8-pin	Cable, open end, 8-wire	2	8080782	NEBC-M12G8-E-2-N-M12G8
			5	8080783	NEBC-M12G8-E-5-N-M12G8
			10	8080784	NEBC-M12G8-E-10-N-M12G8
			15	8080785	NEBC-M12G8-E-15-N-M12G8

Note
The cables are positioned at a 45° angle to the axis.

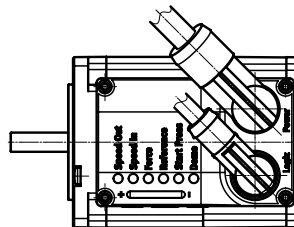

Ordering data – IO-Link master USB					Datasheets → Internet: cdsu
	Description	Cable length [m]	Part no.	Type	
	<ul style="list-style-type: none"> For using the unit with IO-Link An external power supply plug is also required (not included in the scope of delivery) 	0.3	8091509	CDSU-1	

Ordering data – Adapter					Datasheets → Internet: nefc
	Electrical connection, left	Electrical connection, right	Cable length [m]	Part no.	Type
	Straight socket, M12x1, 8-pin	<ul style="list-style-type: none"> Straight plug, M12x1, 5-pin Only recommended for use with IO-Link port class A master 	0.3	8080777	NEFC-M12G8-0.3-M12G5-LK