

Clip fix tool AGTC

FESTO



Clip fix tool AGTC

Key features

At a glance

Principle

The clip fix tool AGTC is a pneumatic mounting device for clips of different designs.

Pressing the clip fix tool with attached clip adapter¹⁾ and clip against the chosen mounting position (hole or pin) triggers a mounting pulse in the

clip fix tool. The clip is fixed via the mounting pulse. The operating pressure level set determines the strength of the mounting pulse. A specific clip adapter¹⁾ is required for mounting different clips.

Note

The clip fix tool must not be used:

- for fitting rivets, nails, screws or other similar parts
- in potentially explosive areas
- on construction sites

- in the production of foodstuffs, cosmetics or pharmaceuticals
- outdoors or in areas that are exposed to moisture
- on scaffolding or ladders

1) The clip adapter is not included in the scope of delivery.

Overview

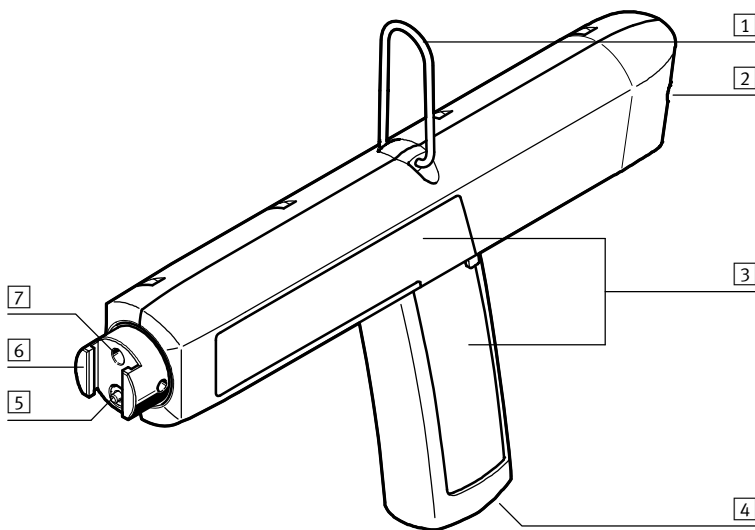

- 1 Clip on first mounting option
- 2 Second mounting option (for clip)
- 3 Gripping surfaces
- 4 Supply port G¹/₄
- 5 Pressure piece with locating pin for fixing the clip adapter
- 6 Interface for clip adapter
- 7 Hole for optional fixing of the clip adapter

Clip adapter

Matching clip adapters **1** for the clip must be manufactured by the operator.

The following specifications for the clip adapter must be observed:

- as light as possible (maximum 50 g)
- made of plastic (e.g. PA, PBT or POM; optionally glass fibre

reinforced)

- sufficient clamping force of the clip when attaching it to the clip adapter (does not fall out on its own accord)
- minimum possible play with respect to the interface. Dimensions of interface → 4

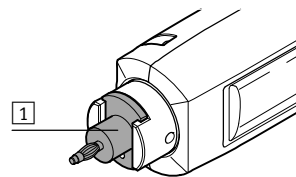

Handling

Connecting compressed air:

Using tubing, connect the clip fix tool to the supply port with a pressure regulator.

Then set the appropriate operating pressure at the pressure regulator for mounting the clip (maximum 6 bar).

Operation:

Press the clip fix tool with the attached clip against the mounting position at right angles to the mounting surface and actuate it. A mounting pulse is triggered and the clip is fixed.

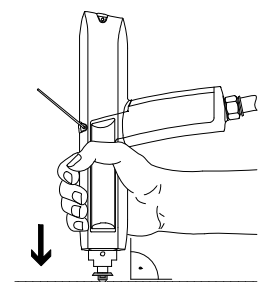
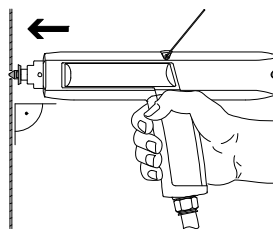

Clip fix tool AGTC

Technical data

FESTO

 - Operating pressure
2 ... 6 bar

 - Temperature range
5 ... 40 °C



General technical data	
Pneumatic port 1	G $\frac{1}{4}$ female thread
Tool holder	T-slot with pressure piece
Valve function	3/2-way valve, closed, monostable
Type of actuation	Mechanical
Max. tightening torque [Nm]	15
Product weight [g]	750

Operating and environmental conditions	
Operating pressure [bar]	2 ... 6
Operating medium	Compressed air to ISO 8573-1:2010 [7:4:4]
Note on operating/pilot medium	Lubricated operation not possible
Ambient temperature [°C]	5 ... 40
Temperature of medium [°C]	5 ... 40
Corrosion resistance class CRC ¹⁾	1
CE marking (see declaration of conformity)	To EC Machinery Directive

- 1) Corrosion resistance class CRC 1 to Festo standard FN 940070
Low corrosion stress. For dry indoor applications or transport and storage protection. Also applies to parts behind covers, in the non-visible interior area, and parts which are covered in the application (e.g. drive trunnions).

Materials	
Housing	Reinforced PA, TPE-S
Tool holder	High-alloy steel
Connecting thread	Anodised wrought aluminium alloy
Clip	Stainless spring steel
Note on materials	RoHS compliant

Mounting pulse (impact energy) E as a function of operating pressure p₁

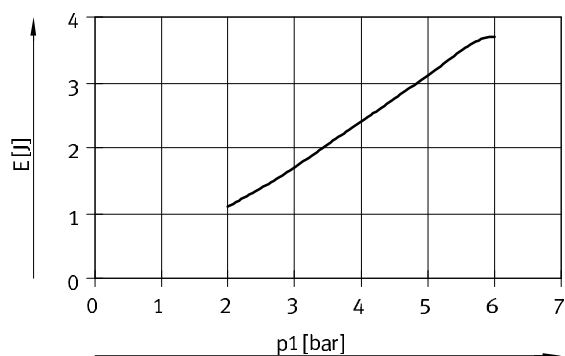

The resulting mounting pulse has a tolerance of $\pm 20\%$

Clip fix tool AGTC

Technical data

FESTO

Dimensions

Download CAD data → www.festo.com

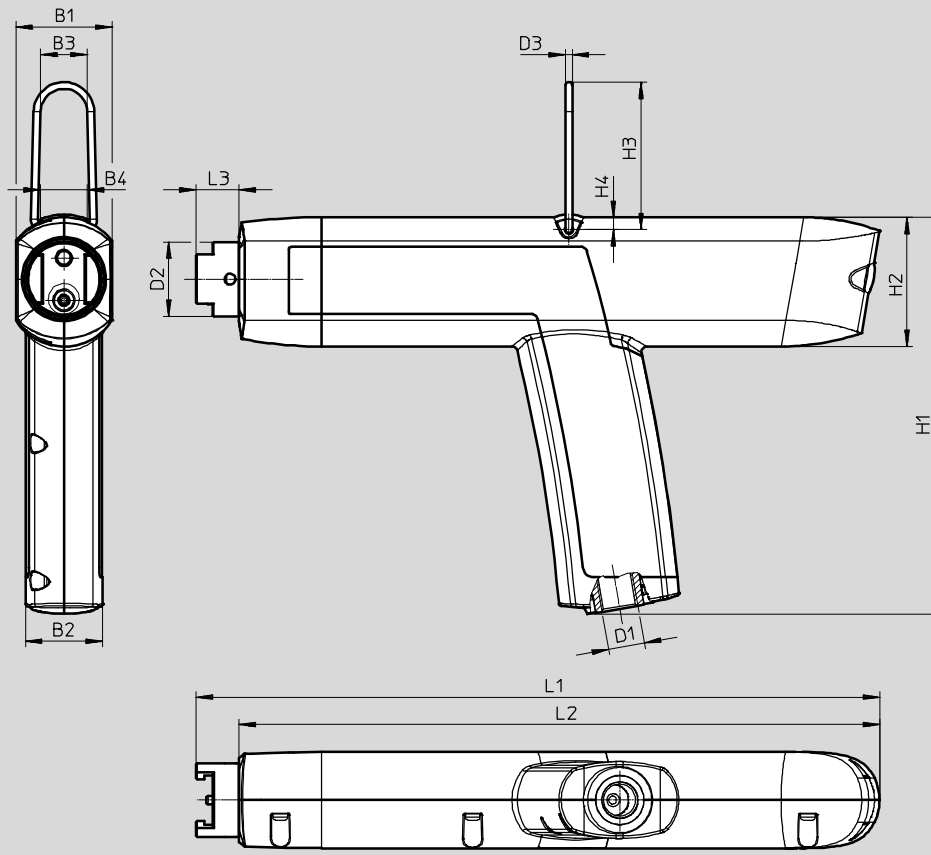

B1	B2	B3	B4	D1	D2 ∅ -0.2	D3 ∅	H1	H2	H3	H4	L1	L2	L3
35	28	17	17	G $\frac{1}{4}$	27	2.5	144.3	47	53.7	4.5	247.7	233.1	14.6

Dimensions – Interface for clip adapter

Download CAD data → www.festo.com

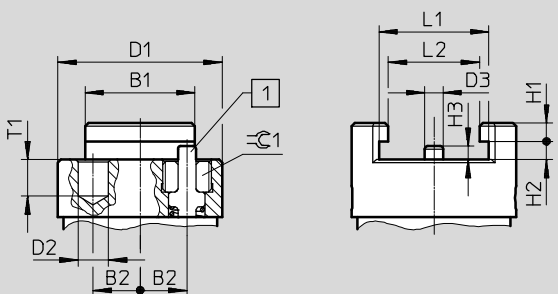

1 Spring-loaded pressure piece with locating pin

To fix the clip adapter in place, it needs a hole for receiving the locating pin (dimension D3). To mount the clip adapter, press it against the locating pin of the pressure piece. Then slide the clip adapter into the T-slot of the interface until the locating pin latches into the drill hole.

The interface also includes a drill hole with a diameter of 5 mm (dimension D2). An additional tool fixture (threaded pin) can be attached to this hole.

B1	B2	D1 ∅ -0.2	D2 ∅ H11	D3 ∅	H1	H2	H3	L1	L2	T1	⌀ 1
18	±0.05 7.7	27	5	3	3	3	2.2	18	15	6	3

Clip fix tool AGTC

Ordering data

Ordering data	
Scope of delivery	Part No. Type
Without accessories	2927782 AGTC-T-SG-1
In the systainer with accessories – Spiral plastic tubing PUN-10X1,5-SG-2,4-BL-1/4 (part no.: 533463) – Push-in fitting NPQH-D-G14-Q10-P10 (part no.: 578343) – Push-in L-fitting NPQH-L-G14-Q10-P10 (part no.: 578285) – Quick coupling plug KS4-1/4-l (part no.: 531678)	2927784 AGTC-T-SG-1+Z1

Ordering data – Accessories						
Spiral plastic tubing PUN-10X1,5-SG						
Number of windings	Working length [m]	Block length [m]	Weight [g]	Colour	Part No.	Type
21	2.4	0.889	180	Blue	533463	PUN-10X1,5-SG-2,4-BL-1/4
50	4.8	1.165	340		533464	PUN-10X1,5-SG-4,8-BL-1/4
66	6	1.317	430		533465	PUN-10X1,5-SG-6-BL-1/4

Festo - Your Partner in Automation



1 Festo Inc.
5300 Explorer Drive
Mississauga, ON L4W 5G4
Canada

Festo Customer Interaction Center
Tel: 1 877 463 3786
Fax: 1 877 393 3786
Email: customer.service.ca@festo.com



2 Festo Pneumatic
Av. Ceylán 3,
Col. Tequesquináhuac
54020 Tlalneptla,
Estado de México

Multinational Contact Center
01 800 337 8669
ventas.mexico@festo.com



3 Festo Corporation
1377 Motor Parkway
Suite 310
Islandia, NY 11749

Festo Customer Interaction Center
1 800 993 3786
1 800 963 3786
customer.service.us@festo.com



4 Regional Service Center
7777 Columbia Road
Mason, OH 45040

Connect with us



www.festo.com/socialmedia



www.festo.com

Subject to change