

Linear gantries EXCT

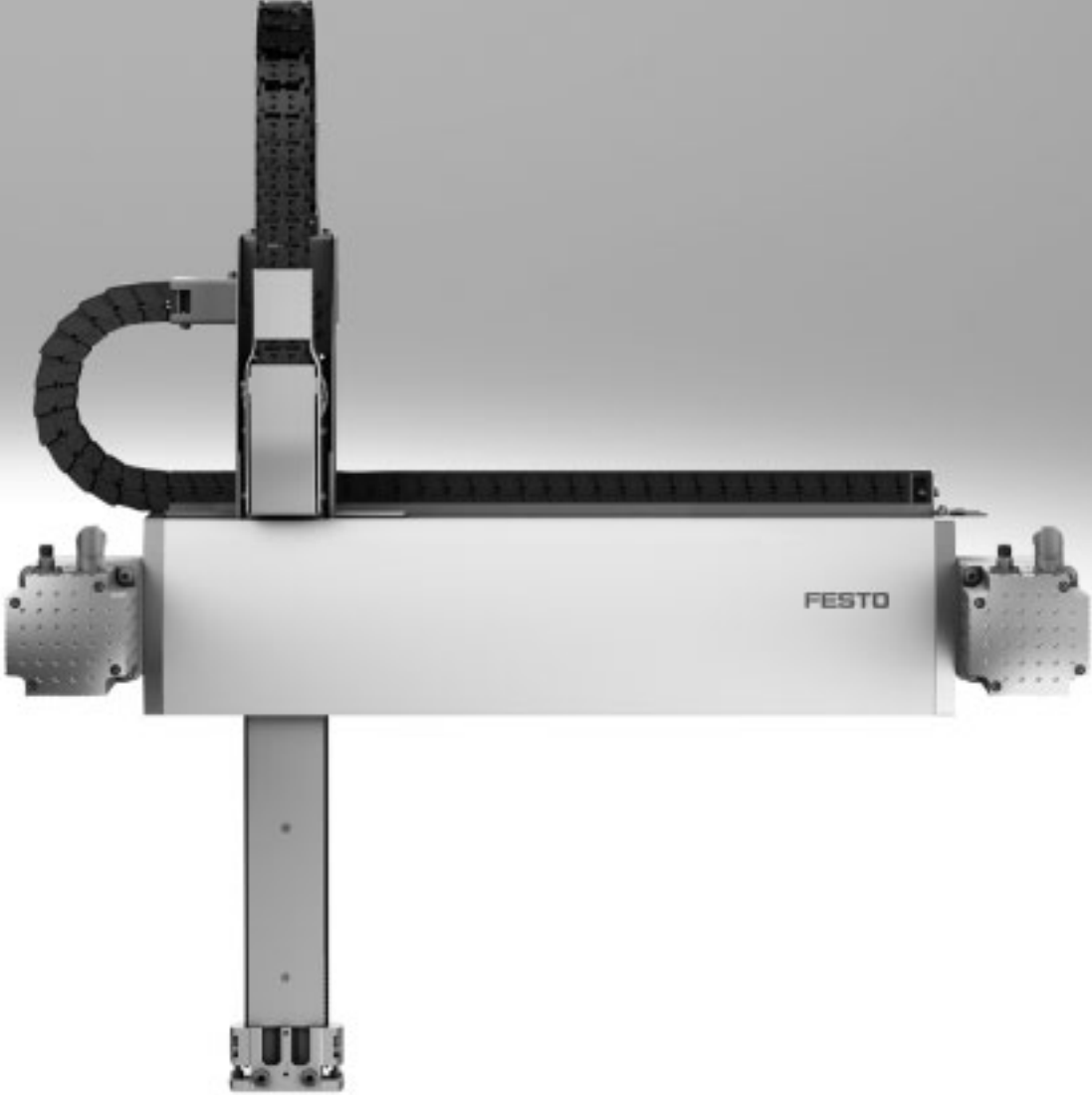

Linear gantries EXCT

Key features

At a glance

General

- Optimal dynamic response when compared with other Cartesian gantry systems
- The drive concept ensures low moving dead weight
- Flat system design
- Perfectly matched drive and controller package
- High acceleration in both axial directions
- Interface for many grippers from Festo

Application examples

- Fast repositioning of parts and modules in a large, rectangular working space, e.g.:
 - Sorting
 - Loading and unloading
 - Gluing and cutting

Operating principle

Two fixed servo motors drive a toothed belt arranged in a T-shape.

The toothed belt moves the slide of the Y-axis and the interface on the Z-axis in a 2-dimensional space.

A controller calculates the position of the interface. The controlled interaction of the motors results in the corresponding movement of the

interface.

The use of attachment components enables additional processes to be carried out.

		Motor 2	
		↺	↻
Motor 1	↺	→	↓
	↻	↗	↖
	↻	↑	←

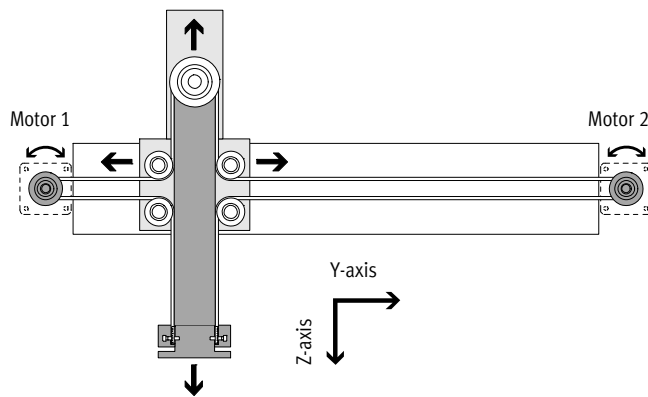

Type		EXCT-15	EXCT-30	EXCT-100
Guide		Recirculating ball bearing guide		
Stroke of the				
Y-axis	[mm]	100 ... 1000	100 ... 1500	100 ... 2000
Z-axis	[mm]	100, 200	250, 500	250, 500, 800
Nominal load for max. dynamic response ¹⁾	[kg]	1.5	3	10
Repetition accuracy	[mm]	±0.1		

1) Nominal load = tool load (attachment component + gripper, for example) + payload

Linear gantries EXCT

Key features

FESTO

Motor attachment variants

EXCT-...-VV – Motor 1 at front, motor 2 at front

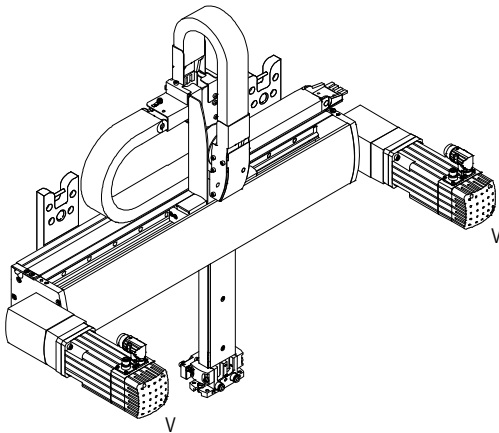

EXCT-...-VH – Motor 1 at front, motor 2 at rear

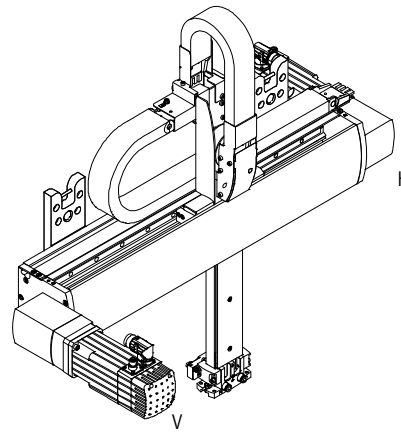

EXCT-...-HV – Motor 1 at rear, motor 2 at front

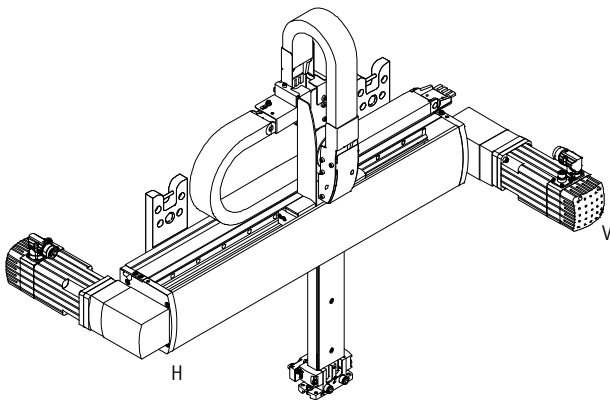

EXCT-...-HH – Motor 1 at rear, motor 2 at rear

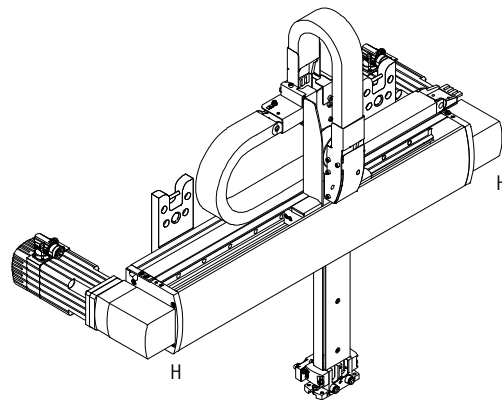

Mounting position

The linear gantry may only be mounted and operated with a vertical Z-axis. The interface for attachment components must be positioned at the bottom.

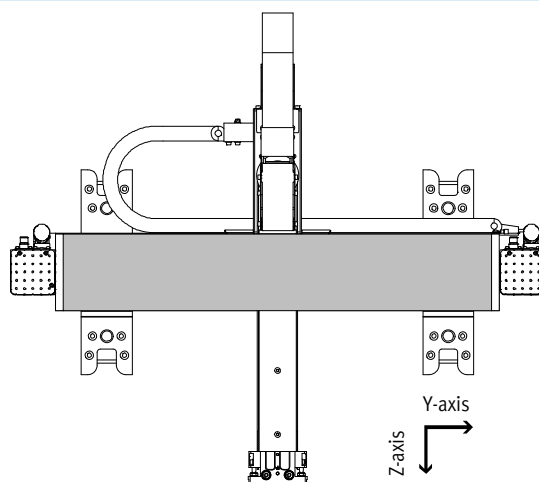

Linear gantries EXCT

Key features

FESTO

Mounting options

Using mounting kit EAHM-E17-K1-...

- For wall mounting
- No adjustment option after mounting

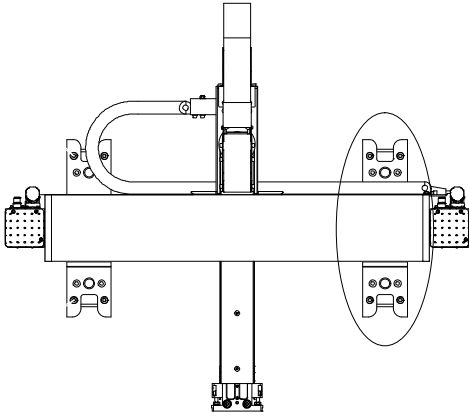

Using mounting kit EAHM-E17-K2-...

- For self-supported mounting
- Each side can be adjusted independently of each other

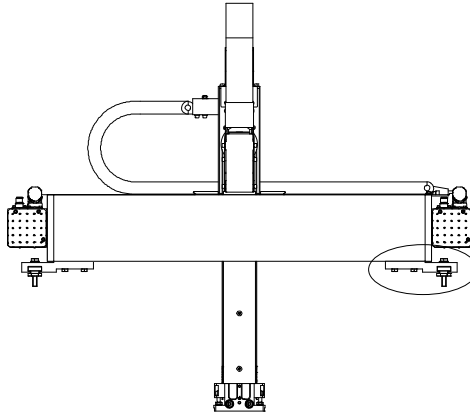

Mounting with slot nuts

- For mounting directly on the machine frame
- No adjustment option following mounting

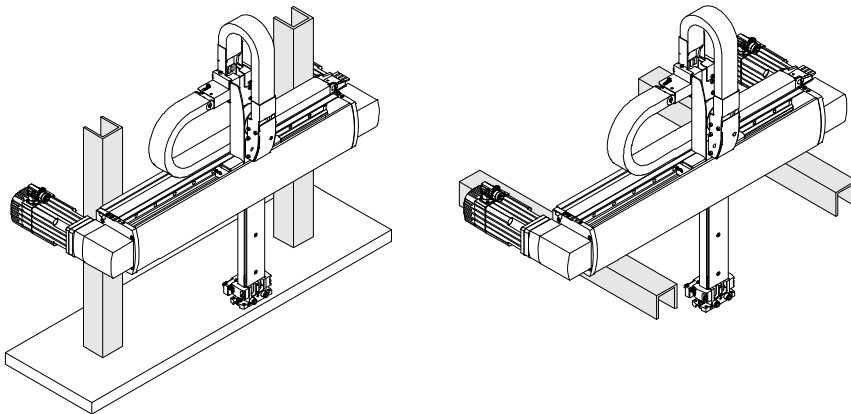

Attachment component for front unit

- A front unit (rotary drive) can be ordered via the modular product system or as an accessory; the front unit is mounted on the Z-axis by means of an adapter plate
- The front unit is available in two sizes (torque 0.75 Nm or 1.8 Nm)
- The front unit can optionally be selected with or without a rotary through-feed (for vacuum or excess pressure)
- When ordering via the modular product system, the front unit, connecting cables and compressed air tubing are installed and connected
- Requires motor controller CMMP-AS → page 34

Technical data → page 22

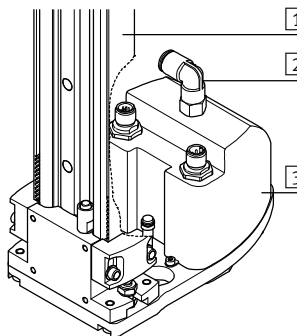

- 1 Linear gantry EXCT-...
- 2 Rotary through-feed
- 3 Rotary drive EXCT-...-T1 to T4

Linear gantries EXCT

Type codes

EXCT - 30 - 500 - 500 - KF - AB - VV - L - T2 - 5K - MP1 - DE

Type

EXCT	Linear gantry
------	---------------

Size

Stroke of the Y-axis [mm]

Stroke of the Z-axis [mm]

Guide

KF	Recirculating ball bearing guide
----	----------------------------------

Motor type

W	Without motor
AB	Servo motor with brake

Motor attachment position

HH	Motor 1 at rear, motor 2 at rear
HV	Motor 1 at rear, motor 2 at front
VH	Motor 1 at front, motor 1 at rear
VV	Motor 1 at front, motor 2 at front

Energy chain connection side

L	Left
R	Right

Attachment components (front unit)

T0	Without attachment components
T1	Rotary drive, size 8
T2	Rotary drive, size 8 with pneum. rotary through-feed
T3	Rotary drive, size 11
T4	Rotary drive, size 11 with pneum. rotary through-feed

Cable length [m]

-	None
5K	5 m
10K	10 m

Installation

-	None
MP1	Multi-pin plug distributor 4 x M8, with pneumatic cables

Document language

DE	German
EN	English
ES	Spanish
FR	French
IT	Italian
RU	Russian
ZH	Chinese

-  Note
Ordering data → page 26

Linear gantries EXCT

Peripherals overview

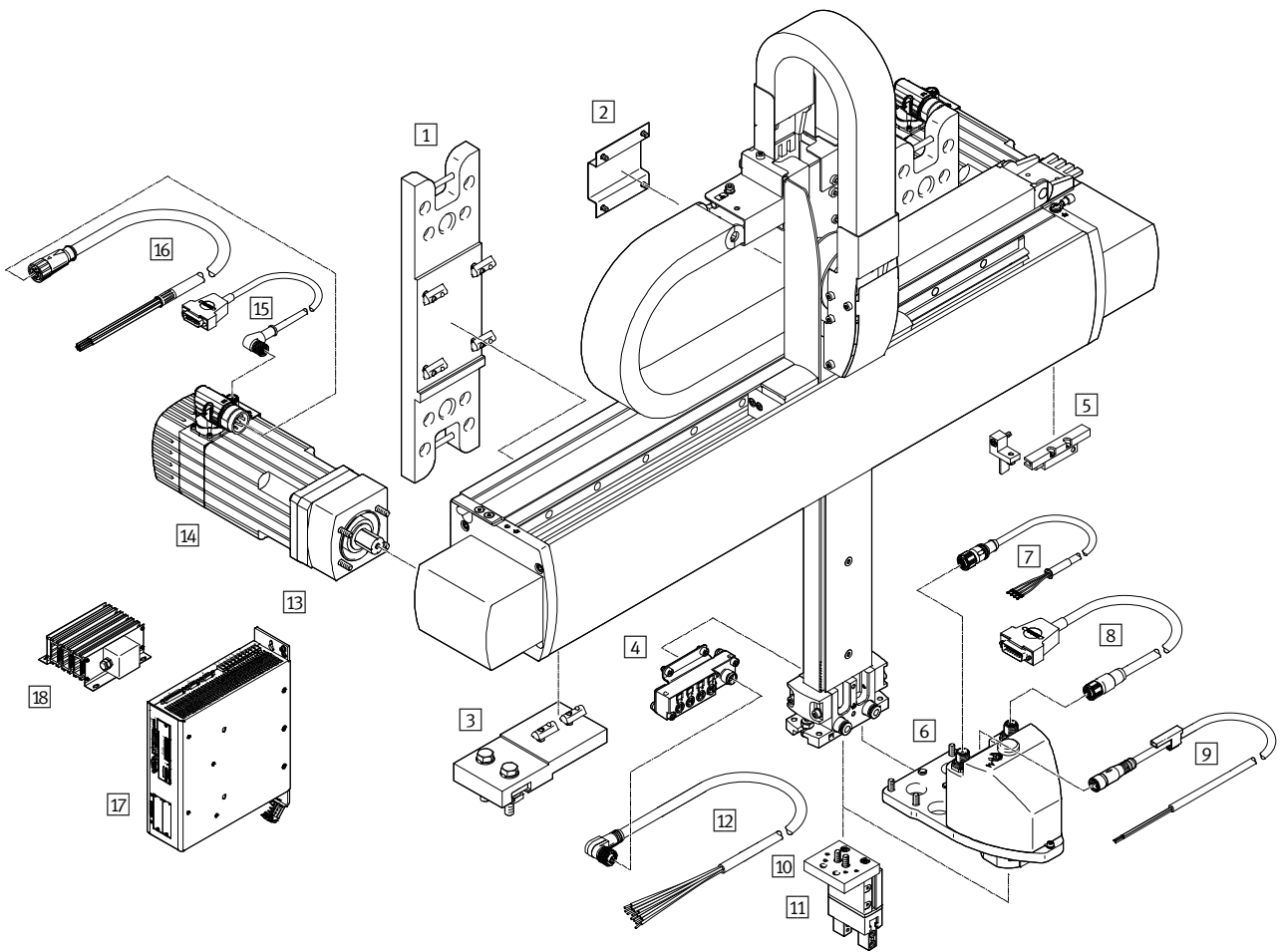

Linear gantries EXCT

Peripherals overview

Attachments and accessories		
Type	Description	→ Page/Internet
1 Mounting kit EAHM-E17-K1	<ul style="list-style-type: none"> For mounting on a wall Included in the scope of delivery of the linear gantry EXCT-... 	28
2 Adapter kit EAHM-E17-U	<ul style="list-style-type: none"> For mounting e.g. valves, vacuum generators etc. Mounting holes must be drilled by the customer Not included in the scope of delivery of the linear gantry 	32
3 Mounting kit EAHM-E17-K2	<ul style="list-style-type: none"> Height-adjustable mounting kit Not included in the scope of delivery of the linear gantry 	29
4 Multi-pin plug set EADH-E17-MP1	<ul style="list-style-type: none"> For connecting up to 4 inputs/outputs Included in the scope of delivery of the linear gantry EXCT-...-MP1 	31
5 Sensing kit EAPR-E17-S	<ul style="list-style-type: none"> For position sensing on the Y-axis Included in the scope of delivery: proximity sensor SIES-Q8B, sensor bracket, switch lug, mounting bracket and screws Not included in the scope of delivery of the linear gantry 	30
6 Front unit ERMH-...-E17	Choose from: <ul style="list-style-type: none"> Without front unit (rotary drive T0) With front unit (rotary drive T1 to T4). The connecting cables and compressed air tubing are delivered installed and connected 	33
7 Motor cable NEBM-M12G4	<ul style="list-style-type: none"> Connecting cable between motor for the front unit and motor controller Included in the scope of delivery of the linear gantry EXCT-...-T... 	34
8 Encoder cable NEBM-M12G12	<ul style="list-style-type: none"> Connecting cable between motor for the front unit and motor controller Included in the scope of delivery of the linear gantry EXCT-...-T... 	34
9 Connecting cable NEBU	<ul style="list-style-type: none"> Connecting cable between reference switch for the front unit and motor controller Included in the scope of delivery of the linear gantry EXCT-...-T... 	34
10 Adapter plate HMSV, DHAA	<ul style="list-style-type: none"> For connecting linear gantry and gripper 	35
11 Gripper	<ul style="list-style-type: none"> A wide range of grippers is available 	35
12 Plug socket with cable NEBU	<ul style="list-style-type: none"> Connecting cable between multi-pin plug distributor and controller Included in the scope of delivery of the linear gantry EXCT-...-MP1; delivered connected 	33
13 Coupling housing EAMK	<ul style="list-style-type: none"> For connecting third-party motors 	33
14 Servo motor EMMS-AS	Motor sizes specially matched to the axis	emms-as
15 Encoder cable NEBM-M12W8	<ul style="list-style-type: none"> Connecting cable between motor on the Y-axis and motor controller Included in the scope of delivery of the linear gantry EXCT-...-AB... 	34
16 Motor cable NEBM-M23G8	<ul style="list-style-type: none"> Connecting cable between motor on the Y-axis and motor controller Included in the scope of delivery of the linear gantry EXCT-...-AB... 	34
17 Motor controller CMMP-AS	<ul style="list-style-type: none"> For controlling the linear gantry 	27
18 Braking resistor CACR	<ul style="list-style-type: none"> Braking resistors are essential for operation 	33

Linear gantries EXCT

Technical data

FESTO

Size

15, 30, 100



General technical data				
Size		15	30	100
Design		Linear gantry		
Guide		Recirculating ball bearing guide		
Stroke of the				
Y-axis	[mm]	100 ... 1000	100 ... 1500	100 ... 2000
Z-axis	[mm]	100, 200	250, 500	250, 500, 800
Nominal load for max. dynamic response ¹⁾	[kg]	1.5	3	10
Max. process force in Z direction	[N]	100	300	500
Max. torque ²⁾	[Nm]	7.75	12.5	22.1
Max. idling torque ²⁾³⁾	[Nm]	0.51	1.28	2.56
Max. acceleration	[m/s ²]	50	50	30
Max. speed ⁴⁾	[m/s]	4.8	5	4
Repetition accuracy	[mm]	±0.1		
Mounting position		Vertical		
Type of mounting		With mounting kit and slot nuts		

- 1) Nominal load = tool load (attachment component + gripper, for example) + payload
- 2) These values must also be complied with during installation of third-party motors
- 3) At v=0.2 m/s and 45° travel.
- 4) These data apply only under ideal conditions.
For a precise configuration please consult a sales engineer from Festo.

Operating and environmental conditions				
Size		15	30	100
Degree of protection		IP40		
Operating pressure ¹⁾	[bar]	-0.95 ... +8		
Operating medium		Compressed air to 8573-1:2010 [7:4:4]		
Note on operating and pilot medium		Lubricated operation possible (in which case lubricated operation will always be required)		
Ambient temperature ²⁾	[°C]	+10 ... +40		
Storage temperature	[°C]	-10 ... +60		
Relative air humidity	[%]	0 ... 90 (non-condensing)		
Noise level	[dB(A)]	70	78	77
Duty cycle	[%]	100		
CE marking (see declaration of conformity)		To EU EMC Directive ³⁾		

- 1) Permissible operating pressure for connections P1 and P2
- 2) Note operating range of proximity sensors and motors
- 3) For information about the applicability of the component see the manufacturer's EC declaration of conformity at: www.festo.com/sp → Certificates.
If the component is subject to restrictions on usage in residential, office or commercial environments or small businesses, further measures to reduce the emitted interference may be necessary.

Linear gantries EXCT

Technical data

Materials

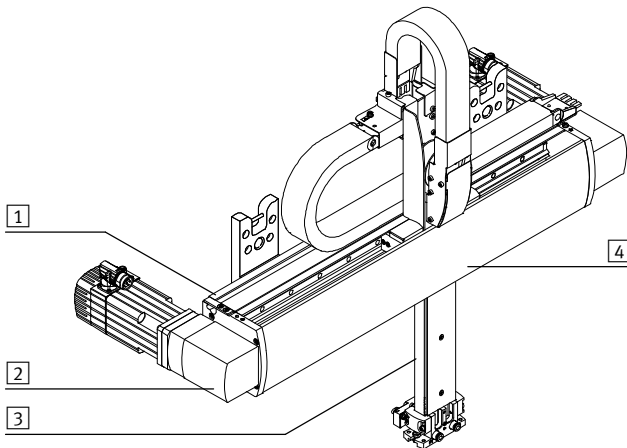

Size	15	30	100
1	Profile of the Y-axis	Anodised aluminium	
2	Drive housing	Anodised aluminium	
3	Profile of the Z-axis	Anodised aluminium	
4	Cover	Anodised aluminium	
–	Guide	High-alloy steel	
	Ball bearings	Steel	
	Toothed belt	PU with steel cord	
Note on materials		RoHS compliant	
		Contains paint-wetting impairment substances	

Weight [kg]			
Size	15	30	100
Product weight at 0 mm stroke (without nominal load, motors, axial kits, mounting kits)			
Y/Z-axis	12.1	25.38	31.65
Additional weight per 100 mm stroke			
Y-axis	0.95	1.48	1.86
Z-axis	0.32	0.37	0.39
Coupling housing	0.45	1.4	1.5
Motor including flange	2.95	7.35	9.55
Attachment component			
EXCT-...-T1	1.08	1.1	–
EXCT-...-T2	1.08	1.1	–
EXCT-...-T3	–	1.30	1.30
EXCT-...-T4	–	1.30	1.30
Multi-pin plug distributor	0.1	0.1	0.1

Linear gantries EXCT

Technical data



Max. acceleration a in Y direction as a function of nominal load m_L , Z-axis stroke l and position of Z-axis l_p

EXCT-15

Z-axis stroke $l = 100$ mm

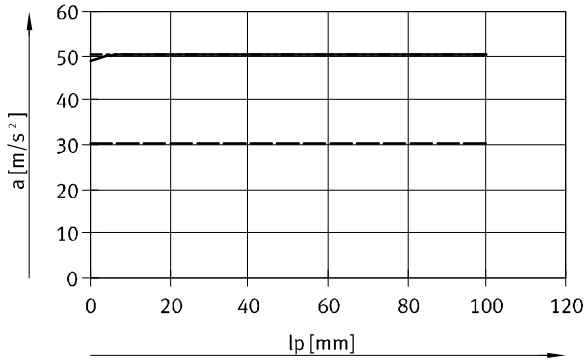

- Nominal load $m_L = 0$ kg
- - - Nominal load $m_L = 1.5$ kg
- · - Nominal load $m_L = 3$ kg

Z-axis stroke $l = 200$ mm

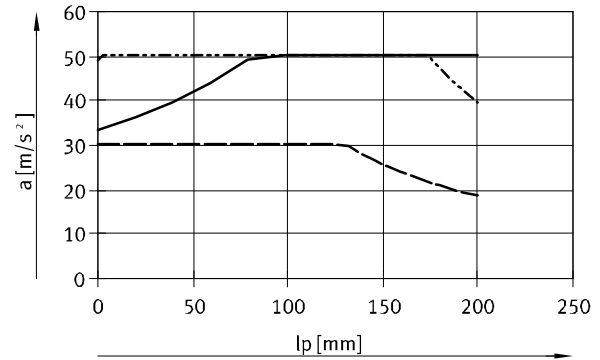

- Nominal load $m_L = 0$ kg
- - - Nominal load $m_L = 1.5$ kg
- · - Nominal load $m_L = 3$ kg

EXCT-30

Z-axis stroke $l = 250$ mm

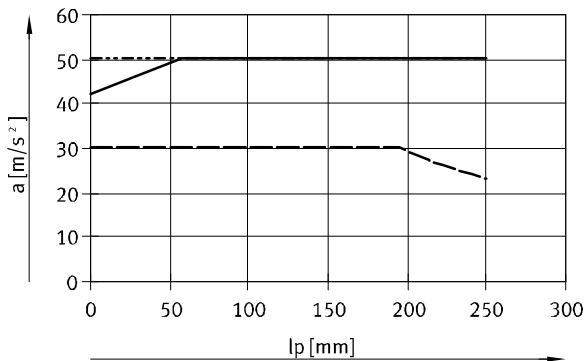

- Nominal load $m_L = 0$ kg
- - - Nominal load $m_L = 3$ kg
- · - Nominal load $m_L = 6$ kg

Z-axis stroke $l = 500$ mm

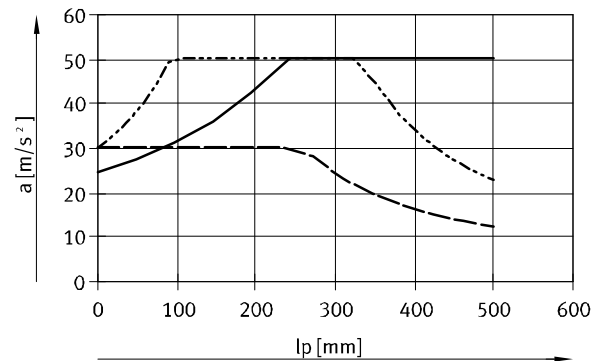

- Nominal load $m_L = 0$ kg
- - - Nominal load $m_L = 3$ kg
- · - Nominal load $m_L = 6$ kg

EXCT-100

Z-axis stroke $l = 250$ mm

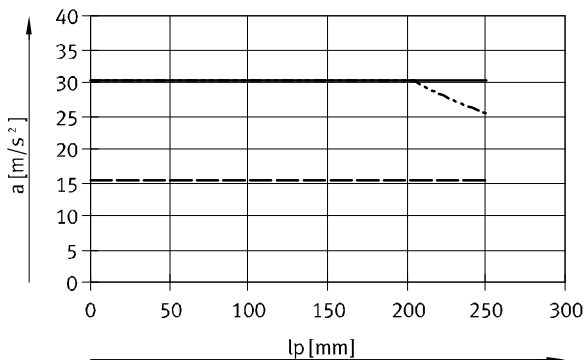

- Nominal load $m_L = 0$ kg
- - - Nominal load $m_L = 10$ kg
- · - Nominal load $m_L = 15$ kg

Z-axis stroke $l = 500$ mm

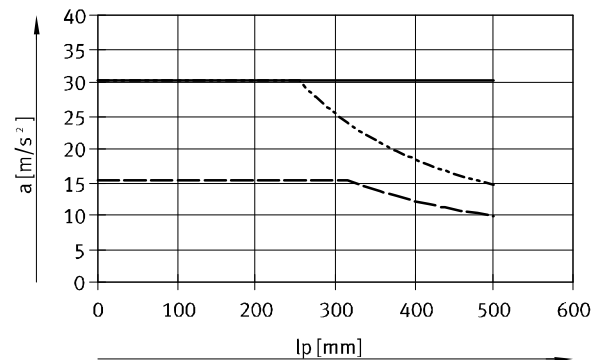

- Nominal load $m_L = 0$ kg
- - - Nominal load $m_L = 10$ kg
- · - Nominal load $m_L = 15$ kg

Linear gantries EXCT

Technical data

Max. acceleration a in Y direction as a function of nominal load m_L , Z-axis stroke l and position of Z-axis l_p

EXCT-100

Z-axis stroke $l = 800$ mm

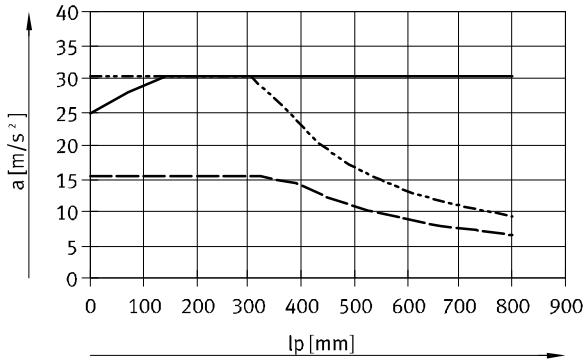

— Nominal load $m_L = 0$ kg
 - - - Nominal load $m_L = 10$ kg
 - · - Nominal load $m_L = 15$ kg

Torque M as a function of rotational speed n

Typical motor characteristic curve with nominal voltage and optimal motor controller. The torque may briefly exceed the nominal torque. The rms value of the torque for the respective positioning cycle must remain below the nominal torque.

EXCT-15

In conjunction with:
 EMMS-AS-70-M-LS-RMB and CMMP-AS-C5-3A

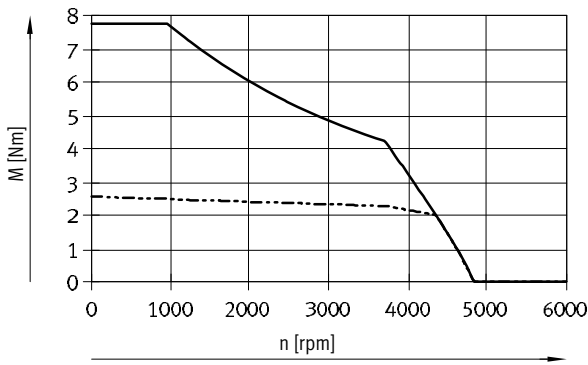

EXCT-30

In conjunction with:
 EMMS-AS-100-S-HS-RMB and CMMP-AS-C5-11A

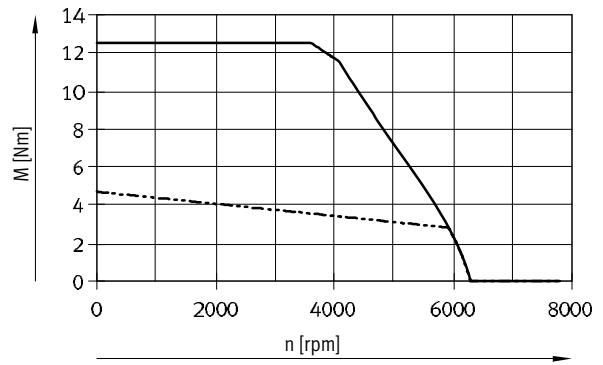

EXCT-100

In conjunction with:
 EMMS-AS-100-M-HS-RMB and CMMP-AS-C5-11A

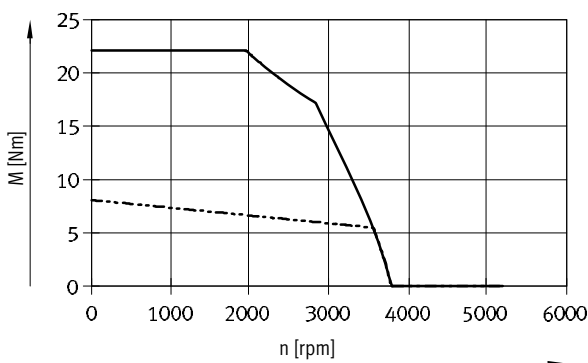

— Max. torque
 - - - Nominal torque

Linear gantries EXCT

Technical data

FESTO

Friction torque M as a function of speed v

EXCT-15

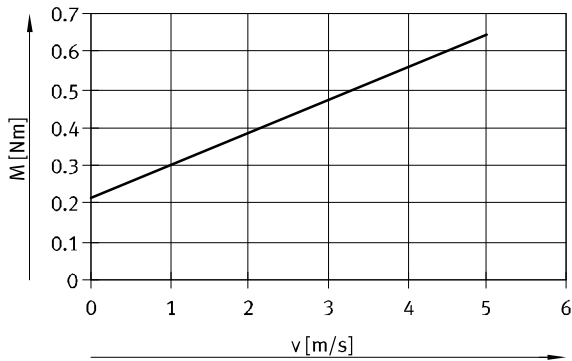

EXCT-30

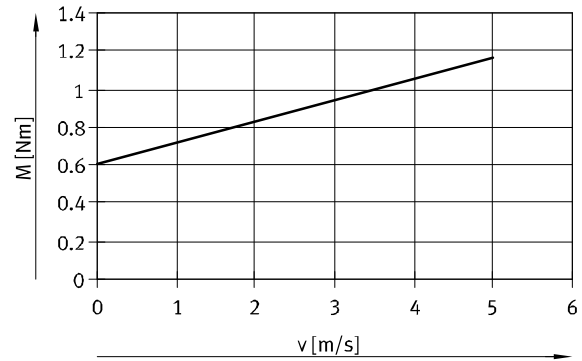

EXCT-100

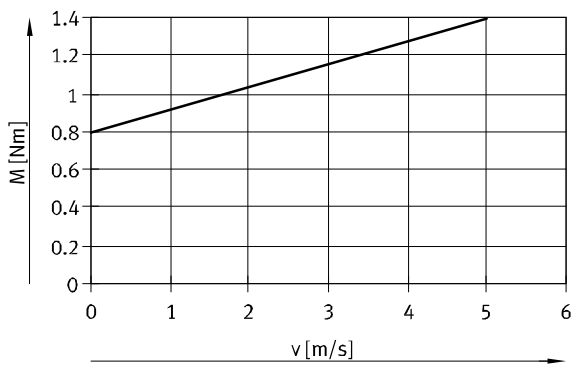

Linear gantries EXCT

Technical data

Characteristic load values

The system is subject to the greatest load in the case of 45° travel.

The following data apply in this case:

Formula for calculating the required torque M and the required nominal rotary speed n

For EXCT-15:

$$n_{45^\circ} = 942.8 \times v$$

and Z-axis stroke = 100 mm:

$$M_{45^\circ} = a \times (10.1 \times m_L + 9.87 \times J_m + 44.4) \times 10^{-3} + 0.07 \times (2.3 + m_L) + M_R$$

and Z-axis stroke = 200 mm:

$$M_{45^\circ} = a \times (10.1 \times m_L + 9.87 \times J_m + 47.5) \times 10^{-3} + 0.07 \times (2.6 + m_L) + M_R$$

For EXCT-30:

$$n_{45^\circ} = 848.5 \times v$$

and Z-axis stroke = 250 mm:

$$M_{45^\circ} = a \times (11.3 \times m_L + 8.89 \times J_m + 99.1) \times 10^{-3} + 0.08 \times (4.7 + m_L) + M_R$$

and Z-axis stroke = 500 mm:

$$M_{45^\circ} = a \times (11.3 \times m_L + 8.89 \times J_m + 108.1) \times 10^{-3} + 0.08 \times (5.5 + m_L) + M_R$$

For EXCT-100:

$$n_{45^\circ} = 678.8 \times v$$

and Z-axis stroke = 250 mm:

$$M_{45^\circ} = a \times (14.1 \times m_L + 7.11 \times J_m + 164.2) \times 10^{-3} + 0.098 \times (6 + m_L) + M_R$$

and Z-axis stroke = 500 mm:

$$M_{45^\circ} = a \times (14.1 \times m_L + 7.11 \times J_m + 178.3) \times 10^{-3} + 0.098 \times (7 + m_L) + M_R$$

and Z-axis stroke = 800 mm:

$$M_{45^\circ} = a \times (14.1 \times m_L + 7.11 \times J_m + 193.8) \times 10^{-3} + 0.098 \times (8.1 + m_L) + M_R$$

- a = acceleration [m/s²]
- v = speed [m/s]
- m_L = attachment component (Z-axis) [kg] with payload
- J_m = moment of inertia of motor [kgcm²]
→ table below
- M_R = friction torque [Nm]
→ page 12
- n_{45°} = nominal speed at 45° travel [rpm]

Allocation of linear gantry – servo motor – motor controller

Linear gantry	Servo motor	Moment of inertia of motor [kgcm ²]
EXCT-15	EMMS-AS-70-M-LS-RMB	0.680
EXCT-30	EMMS-AS-100-S-HS-RMB	3.085
EXCT-100	EMMS-AS-100-M-HS-RMB	5.285

Sample calculation

1. What is the max. load permitted by the mechanical system?

Given:

EXCT-15-500-200-KF-AB-VV-...

with attached motor

EMMS-AS-70-M-LS-RMB

$a_{\max.} = 20 \text{ m/s}^2$

$v_{\max.} = 2 \text{ m/s}$

Nominal load $m_L = 3 \text{ kg}$ (gripper + workpiece)

Position of Z-axis = 70 mm (at max. acceleration in Y-direction)

Calculation:

1. What is the max. acceleration permitted by the mechanical system?

Nominal load $m_L = 3 \text{ kg}$

Z-axis stroke = 200 mm

Position of Z-axis = 150 mm

From the graph:

$a = \text{ca. } 26 \text{ m/s}^2$

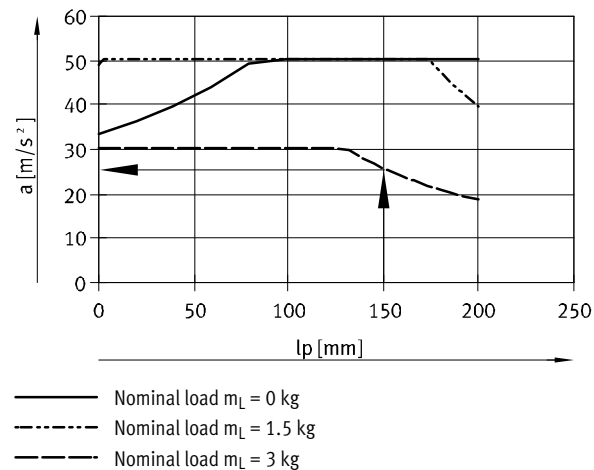

Result:

With a moving mass of 3 kg and a position of the Z-axis of 150 mm, the max. permissible acceleration in the Y-direction is 26 m/s^2 .

The required acceleration of 20 m/s^2 is thus permissible.

Linear gantries EXCT

Technical data

Sample calculation

2. Is the envisaged motor sufficient for this load?

Given:

$$a_{\max.} = 20 \text{ m/s}^2$$

$$v_{\max.} = 2 \text{ m/s}$$

Nominal load $m_L = 3 \text{ kg}$ (gripper + workpiece)

$$J_m = 0.680 \text{ kgcm}^2$$

$$M_{45^\circ} = a \times (10.1 \times m_L + 9.87 \times J_m + 39.2) \times 10^{-3} + 0.07 \times (2.14 + m_L) + M_R$$

$$n_{45^\circ} = 942.7 \times v$$

a = acceleration [m/s²]

v = speed [m/s]

m_L = attachment component (Z-axis) [kg]
with payload

J_m = moment of inertia of motor [kgcm²]

→ table below

M_R = friction torque [Nm]

→ page 12

n_{45° = nominal speed at 45° travel [rpm]

Determining M_{45° :

$$n_{45^\circ} = 942.7 \times 2 \text{ m/s} = 1885.4 \text{ 1/min}$$

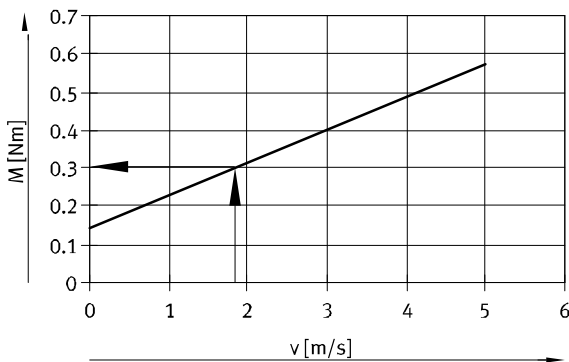

$$M_R = 0.3 \text{ Nm}$$

$$M_{45^\circ} = a \times (10.1 \times m_L + 9.87 \times J_m + 39.2) \times 10^{-3} + 0.07 \times (2.14 + m_L) + M_R$$

$$M_{45^\circ} = 20 \text{ m/s}^2 \times (10.1 \times 3 \text{ kg} + 9.87 \times 0.680 \text{ kgcm}^2 + 39.2) \times 10^{-3} + 0.07 \times (2.14 + 3 \text{ kg}) + 0.3 \text{ Nm} = 2.18 \text{ Nm}$$

Result:

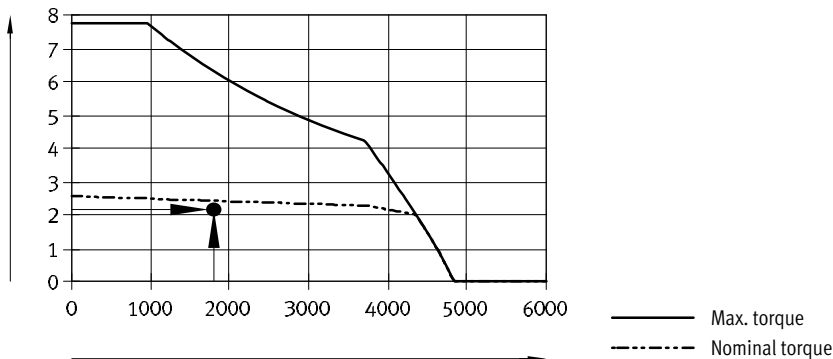

Result:

The value for the torque is just below the nominal torque.

This torque is only required in the acceleration phases.

The design is therefore fine.

Linear gantries EXCT

Technical data

FESTO

Maximum permissible support spacing

In order to limit deflection in the case of large stroke lengths, the axis may need to be supported. An additional mounting kit is therefore required for strokes greater than $L = 1500$ mm.

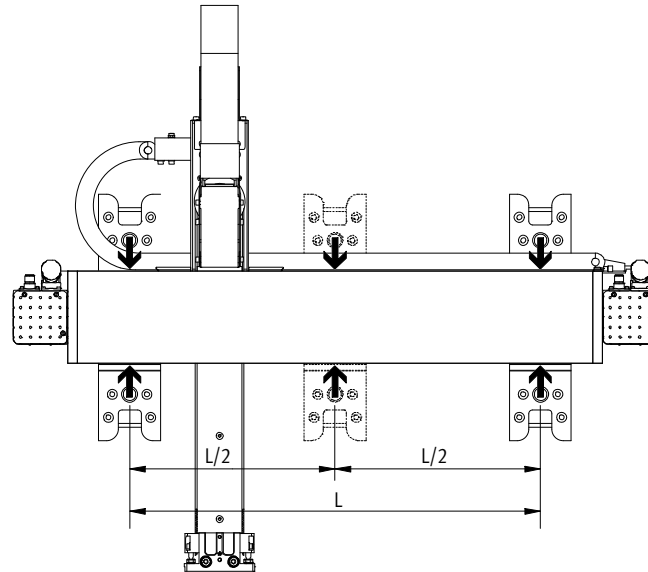

Recommended deflection limits

To avoid impairing the functionality of the gantry, we recommend that the following deflection limits are observed. Deformations greater than these may lead to increased friction, increased wear and reduced service life.

Size	15	30	100
Dynamic deflection (load is moving)	0.03% ¹⁾	0.03% ¹⁾	0.03% ¹⁾
	Max. 0.3 mm	Max. 0.45 mm	Max. 0.6 mm
Static deflection (stationary load)	0.05% ¹⁾	0.05% ¹⁾	0.05% ¹⁾

1) Of the length of the axis

Energy chain

- The cable routing from the cable outlet to the Z-axis uses energy chains [2]
 - When ordering the linear gantry it is possible to select whether the cable outlet to the control cabinet [1] should be to the left or the right
 - The cables are routed within the Z-axis [6] as far as the interface. At the interface, there are two permanent air connections [7].
 - 2 cable lengths (5 m or 10 m) can be selected via the modular product system → page 26. This specifies the length of the motor and encoder cables for the drive motors.
- The tubing and cables that project from the output of the energy chain at the Y-axis [5] are at least 10 m in length.

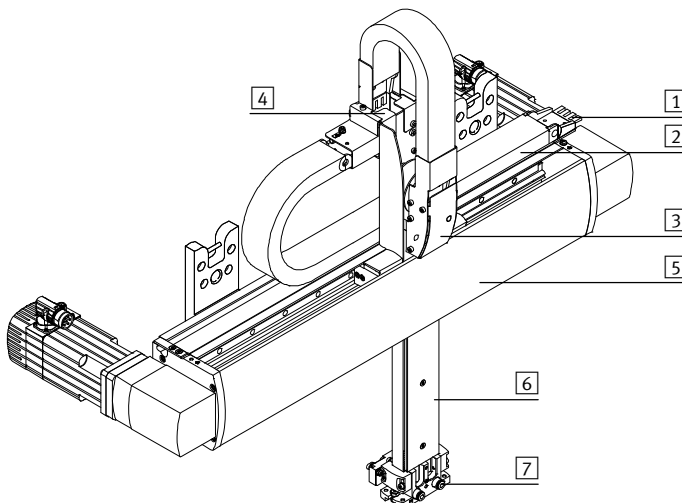

- 1 Cable outlet to the control cabinet
- 2 Energy chain
- 3 Transfer to the Z-axis
- 4 Transfer of the two energy chains
- 5 Y-axis
- 6 Z-axis
- 7 Interface with air connections

Linear gantries EXCT

Technical data

Pin allocations

Motors for the Y-axis

Motor (M23, pins)

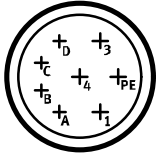

Encoder (M12, pins)

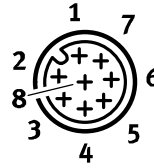

PIN	Function	Colour
1	U Phase U	BK (1)
PE	PE Protective earth	GNYE
3	W Phase W	BK (3)
4	V Phase V	BK (2)
A	M _{T+} Temperature sensor	WH
B	M _{T-} Temperature sensor	BN
C	BR+ Brake	GN
D	BR- Brake	YE

PIN	Function
1	-SENS
2	+SENS
3	DATA
4	DATA/
5	0 V
6	CLOCK/
7	CLOCK
8	UP

Allocation of linear gantry – servo motor – motor controller

Linear gantry	Servo motor	Motor controller
EXCT-15	EMMS-AS-70-M-LS-RMB	CMMP-AS-C5-3A
EXCT-30	EMMS-AS-100-S-HS-RMB	CMMP-AS-C5-11A-P3
EXCT-100	EMMS-AS-100-M-HS-RMB	CMMP-AS-C5-11A-P3

-  - Note

Third-party motors that have an overly high drive torque may damage the linear gantry. When selecting the motors, please observe the limits specified in the technical data.

During commissioning, the motor brake must be released for safety purposes. We recommend the teach pendant CDSA (➔ modular product system) for this purpose.

Linear gantries EXCT

Technical data

FESTO

Dimensions

Download CAD data → www.festo.com

Linear gantry

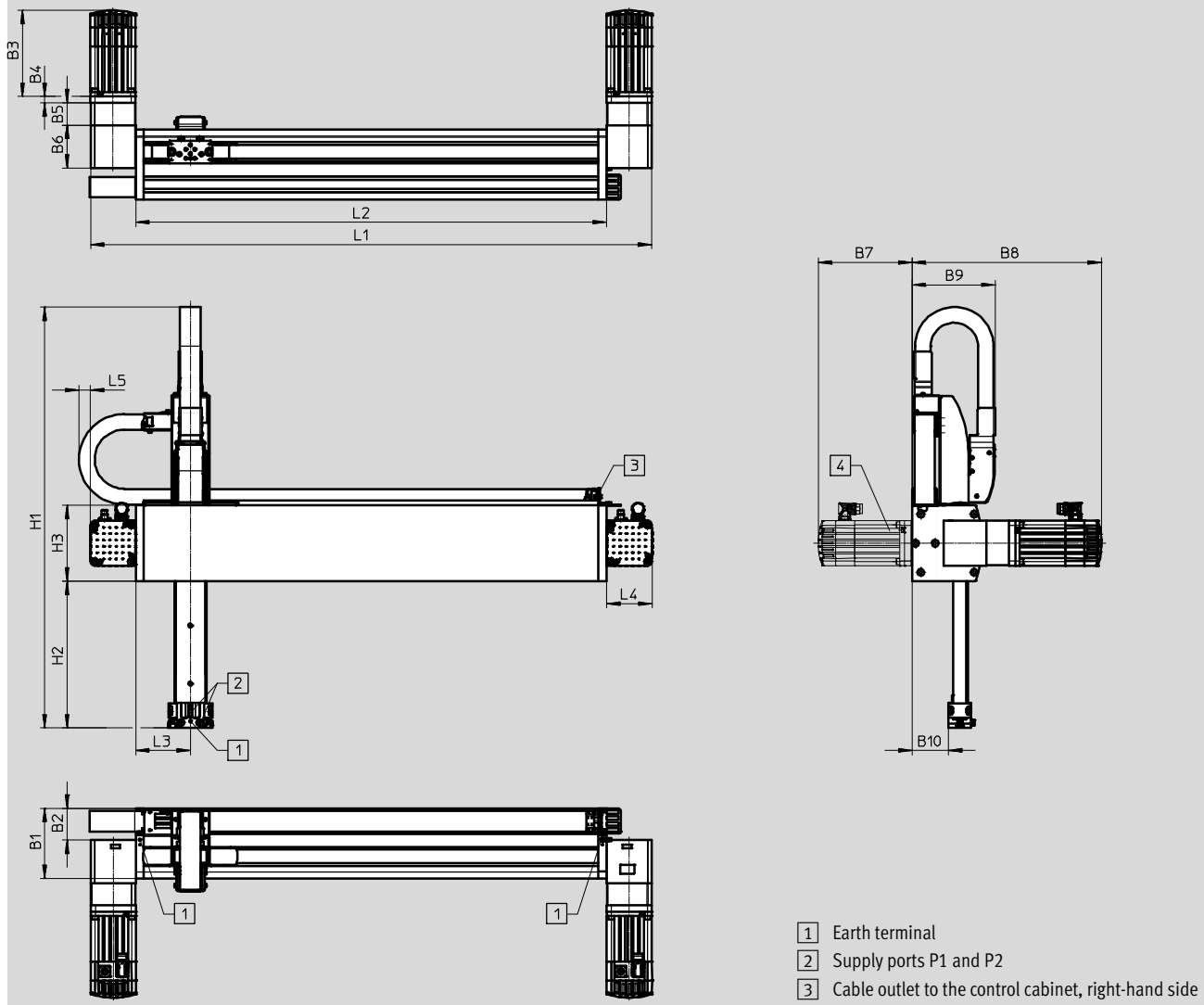

Linear gantries EXCT

Technical data



Size	B1	B2	B3	B4	B5	B6	B7	B8	B9	B10	H3	L4	L5
15	121	57.6	187.3	12.2	29.2	89	202	375	138.1	66	120	71	25
30	157	71	192.3	14.5	49.5	96	209	423	186	81.5	170	102	25
100	184	94	243.3	14.5	49	123	260	524	211	106.5	200	102	25

Stroke-dependent dimensions

Size	Y-axis stroke	L1	L2	L3
15	100 ... 1000	336+stroke	194+stroke	94+software end positions
30	100 ... 1500	456+stroke	252+stroke	122+software end positions
100	100 ... 2000	468+stroke	264+stroke	128+software end positions

Size	Z-axis stroke	H1	H2
15	100	636	170
	200	736	270
	Stroke	536+stroke	70+stroke
30	250	942	328
	500	1192	578
	Stroke	692+stroke	78+stroke
100	250	991	336
	500	1241	586
	800	1541	886
	Stroke	741+stroke	86+stroke

Note

Requirements for the evenness of the support surface and for the attachments → www.festo.com/sp
User documentation

Factoring in software end positions

When selecting the strokes for the Y- and Z-axis, the dimension L3 for the software end positions must be factored into the working stroke L2. This dimension is freely selectable. Adjustment pieces with L3 = 30 mm are included in the scope of delivery of the linear gantry.

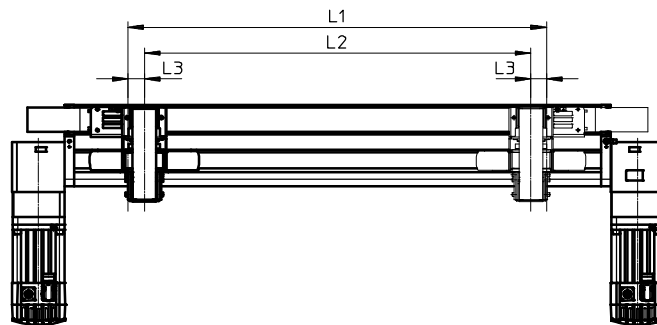

Stroke L1 = working stroke L2 + 2x software end position L3

Linear gantries EXCT

Technical data

FESTO

Dimensions

Download CAD data → www.festo.com

Interface of attachment component with air connections P1 and P2

EXCT-15/-30

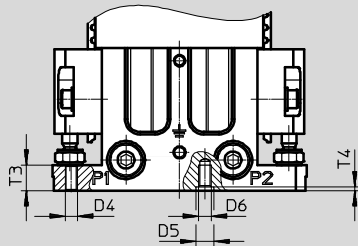
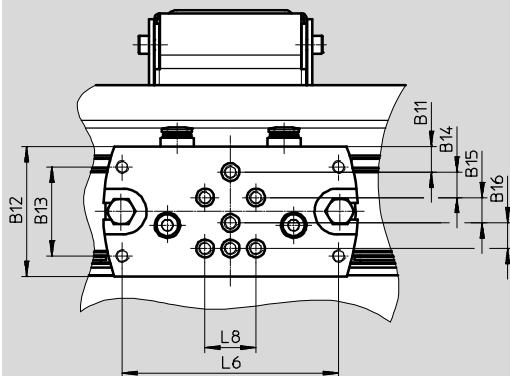

EXCT-100

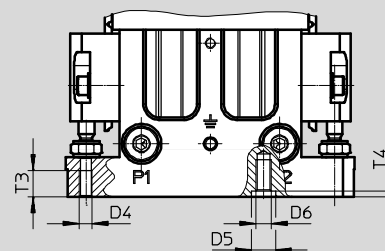
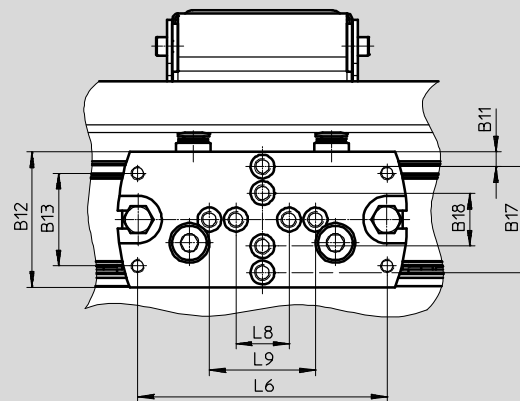

- Note

Tubing with outside diameter of 6 mm can be connected to ports P1 and P2.

For size	B11	B12	B13	B14	B15	B16	B17	B18
15	5	41	31	10	10	10	-	-
30	10	51	35	10	10	10	-	-
100	5.5	51	35	-	-	-	40	20

For size	D4	D5 ∅ H7	D6	L6	L8	L9	T3	T4 +0.1
15	M5	7	M5	76	20	-	10	1.6
30	M5	7	M5	85	20	-	10	1.6
100	M5	9	M6	94	20	40	15	2.1

Linear gantries EXCT

Technical data

Dimensions

Download CAD data → www.festo.com

Motor interface

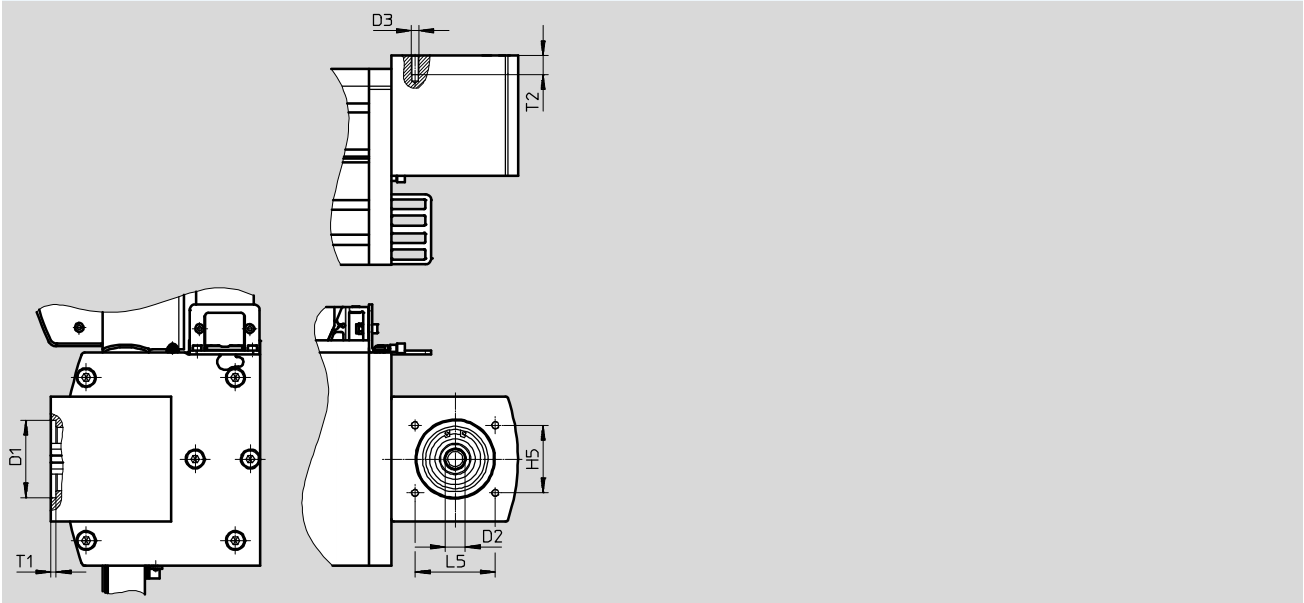

For size	D1 ∅ +0.05	D2 ∅ H7	D3	H5	L5	T1	T2
15	48	16	M5	35	46	4	15
30	62	16	M6	54	64	4	15
100	72	23	M6	54	64	4	15

Linear gantries EXCT

Technical data

FESTO

Technical data – Front unit

EXCT-...-T...

Can be ordered via:

Modular product system → page 26

Or accessories → page 33

Requires motor controller CMMP-AS

→ page 34

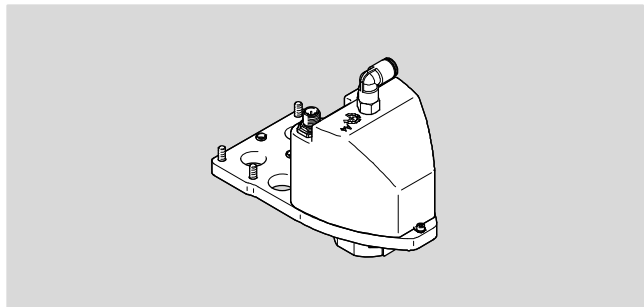

Technical data				
Type	EXCT-...-			
	T1	T2	T3	T4
Design	Electromechanical rotary drive			
	-	With rotary through-feed	-	With rotary through-feed
Motor type	Servo motor			
Size	8		11	
Rotation angle	Infinite			
Pneumatic connection	-	G1/8	-	G1/8
Nominal width [mm]	-	4	-	4
Standard flow rate [l/min]	-	350	-	350
Gear ratio	30:1			
Repetition accuracy [°]	±0.01			
Max. output speed [rpm]	200			
Nominal torque [Nm]	0.75		1.8	
Peak torque [Nm]	1.8		4.5	
Max. axial force [N]	200		300	
Max. pull-out torque, static [Nm]	15		40	

Electrical data				
Type	EXCT-...-			
	T1	T2	T3	T4
Nominal voltage [V AC]	230			
Nominal current [A]	0.31	0.31	0.74	0.74
Peak current [A]	0.61	0.61	1.5	1.5
Rated output [W]	9.2	9.2	22.1	22.1
Duty cycle [%]	100			
Measuring system ¹⁾	Encoder			

1) Homing required

Linear gantries EXCT

Technical data

Operating and environmental conditions					
Type		EXCT-...			
		T1	T2	T3	T4
Operating pressure	[bar]	-	-0.9 ... +8	-	-0.9 ... +8
Ambient temperature	[°C]	0 ... 40			
Storage temperature	[°C]	-10 ... +60			
Degree of protection		IP40			
Note on materials		RoHS compliant			

Front unit motor

Motor

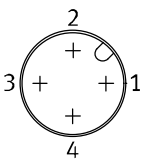

PIN	Function
1	Operating voltage U
2	Operating voltage V
3	Operating voltage W
4	Protective earth conductor PE

Encoder

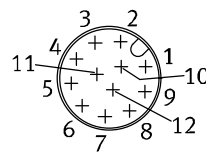

PIN	Function
1	Signal trace A
2	Signal trace A\
3	Signal trace B
4	Signal trace B\
5	Signal trace Z
6	Signal trace Z\
7	Signal trace U
8	Signal trace V
9	Signal trace W
10	GND encoder
11	Power supply 5V
12	Screening

Linear gantries EXCT

Technical data

FESTO

Dimensions

Download CAD data → www.festo.com

Front unit

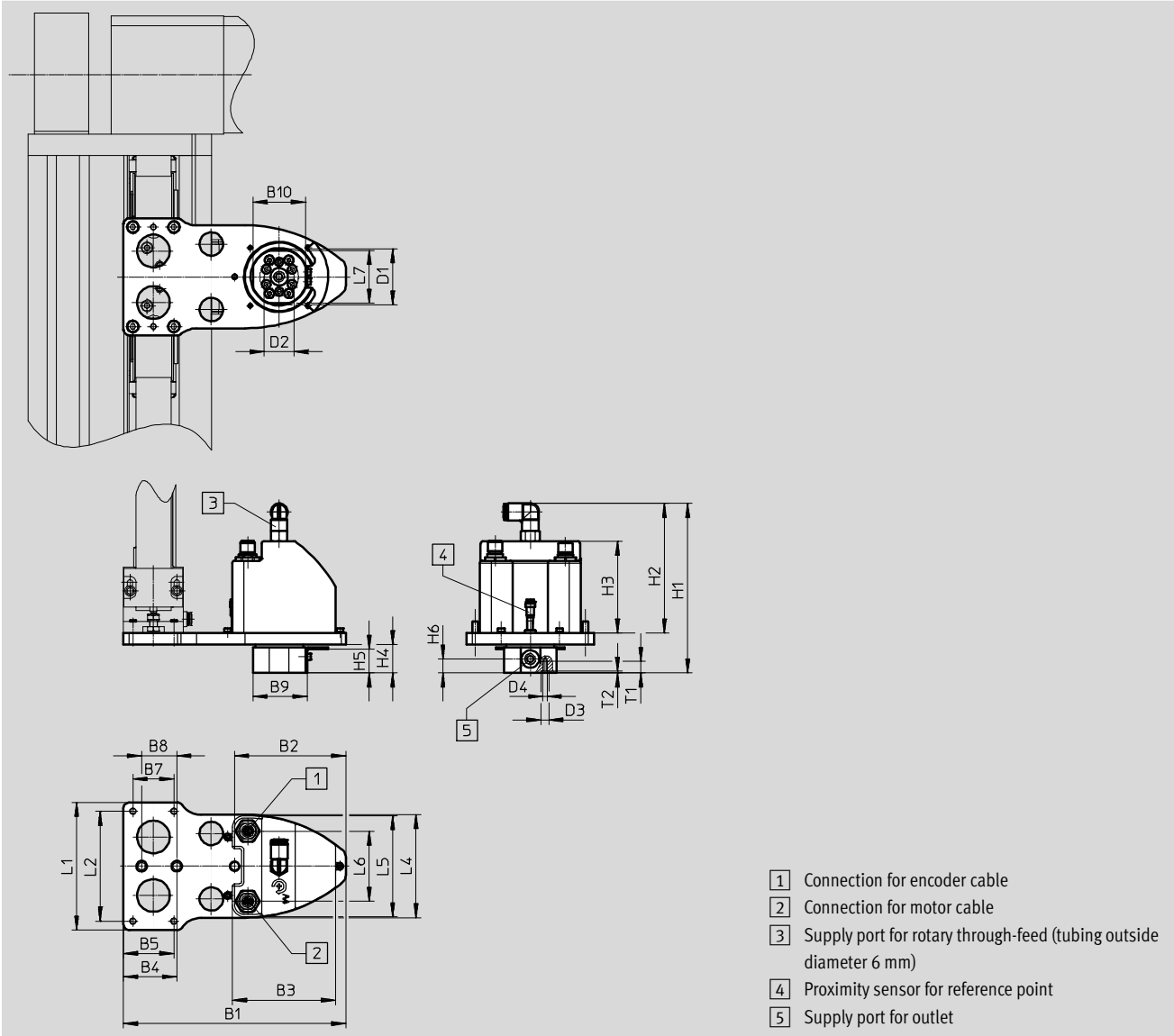

Linear gantries EXCT

Technical data

For linear gantry	Type	B1	B2	B3	B4	B5	B7	B8	B9	B10
EXCT-15-...-T1	ERMH-8-E17-15	170	95	88	36	36	31	30	46.5	45
EXCT-15-...-T2	ERMH-8-P-E17-15	170	95	88	36	36	31	30	46.5	45
EXCT-30-...-T1	ERMH-8-E17-30	190	95	88	41	43	35	30	46.5	45
EXCT-30-...-T2	ERMH-8-P-E17-30	190	95	88	41	43	35	30	46.5	45
EXCT-30-...-T3	ERMH-11-E17-30	190	95	88	41	43	35	30	46.5	45
EXCT-30-...-T4	ERMH-11-P-E17-30	190	95	88	41	43	35	30	46.5	45
EXCT-100-...-T3	ERMH-11-E17-100	190	95	88	45.5	43	35	30	46.5	45
EXCT-100-...-T4	ERMH-11-P-E17-100	190	95	88	45.5	43	35	30	46.5	45

For linear gantry	Type	D1 Ø	D2 Ø	D3 Ø H7	D4	H1	H2	H3	H4	H5	H6
EXCT-15-...-T1	ERMH-8-E17-15	48	25	7	M4	116.4	83.8	78.4	22.6	20.5	12
EXCT-15-...-T2	ERMH-8-P-E17-15	48	25	7	M4	141	106.7	78.4	22.6	20.5	12
EXCT-30-...-T1	ERMH-8-E17-30	48	25	7	M4	116.4	83.8	78.4	22.6	20.5	12
EXCT-30-...-T2	ERMH-8-P-E17-30	48	25	7	M4	141	106.7	78.4	22.6	20.5	12
EXCT-30-...-T3	ERMH-11-E17-30	48	25	7	M4	116.4	83.8	78.4	24.3	20.5	12
EXCT-30-...-T4	ERMH-11-P-E17-30	48	25	7	M4	141	106.7	78.4	24.3	20.5	12
EXCT-100-...-T3	ERMH-11-E17-100	48	25	7	M4	116.4	83.8	78.4	24.3	20.5	12
EXCT-100-...-T4	ERMH-11-P-E17-100	48	25	7	M4	141	106.7	78.4	24.3	20.5	12

For linear gantry	Type	L1	L2	L4	L5	L6	L7	T1	T2
EXCT-15-...-T1	ERMH-8-E17-15	92	76	88	86.3	60	45	10	1.6
EXCT-15-...-T2	ERMH-8-P-E17-15	92	76	88	86.3	60	45	10	1.6
EXCT-30-...-T1	ERMH-8-E17-30	100	85	88	86.3	60	45	10	1.6
EXCT-30-...-T2	ERMH-8-P-E17-30	100	85	88	86.3	60	45	10	1.6
EXCT-30-...-T3	ERMH-11-E17-30	100	85	88	86.3	60	45	10	1.6
EXCT-30-...-T4	ERMH-11-P-E17-30	100	85	88	86.3	60	45	10	1.6
EXCT-100-...-T3	ERMH-11-E17-100	109	94	88	86.3	60	45	10	1.6
EXCT-100-...-T4	ERMH-11-P-E17-100	109	94	88	86.3	60	45	10	1.6

Linear gantries EXCT

Ordering data – Modular product system



Ordering table						
Size	15	30	100	Condi- tions	Code	Entry code
M Module no.	8026575	8026576	8026577			
Product type	T series				EXCT	EXCT
Size	15	30	100		-...	
Y-axis stroke [mm]	100 ... 1000	100 ... 1500	100 ... 2000		-...	
Z-axis stroke [mm]	100, 200	250, 500	250, 500, 800		-...	
Guide	Recirculating ball bearing guide				-KF	-KF
Motor type	Without motor			1	-W	
	Servo motor with brake				-AB	
Motor attachment position	Motor 1 at rear, motor 2 at rear				-HH	
	Motor 1 at rear, motor 2 at front				-HV	
	Motor 1 at front, motor 2 at rear				-VH	
	Motor 1 at front, motor 2 at front				-VV	
Energy chain connection side	Left-hand				-L	
	Right-hand				-R	
Attachment components (front unit)	None				-T0	
	Rotary drive, size 8		-		-T1	
	Rotary drive, size 8 with pneum. rotary through-feed		-		-T2	
	-	Rotary drive, size 11			-T3	
	-	Rotary drive, size 11 with pneum. rotary through-feed			-T4	

1 W Not in combination with 5K, 10K, MP1

- M** Mandatory data
- O** Options

Transfer order code

Linear gantries EXCT

Ordering data – Modular product system

Ordering table						
Size	15	30	100	Condi- tions	Code	Entry code
[O] Line length	None					
	5 m				-5K	
	10 m				-10K	
	Installation					
[M] Document language	None					
	Multi-pin plug distributor 4 x M8, with pneumatic cables				-MP1	
[M] Document language	German				-DE	
	English				-EN	
	Spanish				-ES	
	French				-FR	
	Italian				-IT	
	Russian				-RU	
	Chinese				-ZH	

Combinations of attachment components for motor controller		
Linear gantry	Attachment components for Z-axis	Motor controller
EXCT-15-...	T0	2x CMMP-AS-C5-3A
	One attachment component (T1, T2)	2x CMMP-AS-C5-3A, 1x CMMP-AS-C2-3A
	Two attachment components (T1, T2 and electric gripper)	2x CMMP-AS-C5-3A, 2x CMMP-AS-C2-3A
EXCT-30-...	T0	2x CMMP-AS-C5-11A-P3
	One attachment component (T1, T2, T3, T4)	2x CMMP-AS-C5-11A-P3, 1x CMMP-AS-C2-3A
	Two attachment components (T1, T2, T3, T4 and electric gripper)	2x CMMP-AS-C5-11A-P3, 2x CMMP-AS-C2-3A
EXCT-100-...	T0	2x CMMP-AS-C5-11A-P3
	One attachment component (T3, T4)	2x CMMP-AS-C5-11A-P3, 1x CMMP-AS-C2-3A
	Two attachment components (T3, T4 and electric gripper)	2x CMMP-AS-C5-11A-P3, 2x CMMP-AS-C2-3A

 Note
The motor controller must be ordered separately as an accessory → page 34.
Control system on request.

- [M] Mandatory data
- [O] Options

Transfer order code

- - -

Linear gantries EXCT

Accessories



Mounting kit EAHM-E17-K1

For wall mounting

Materials:
Wrought aluminium alloy

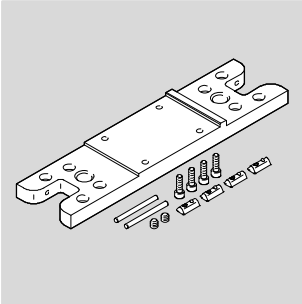

EXCT-15

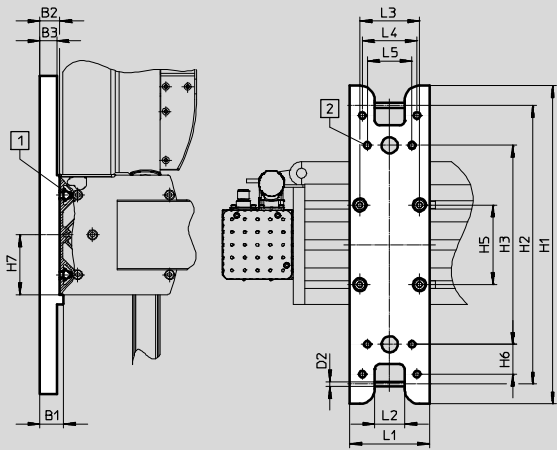

EXCT-30/-100

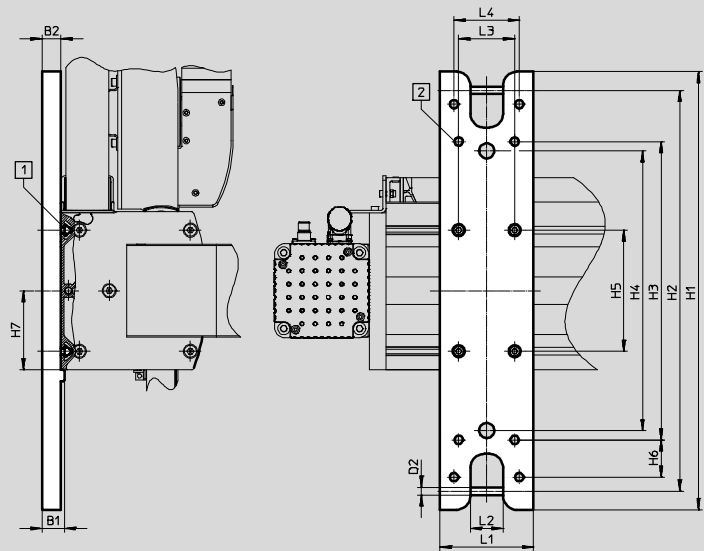

- 1 Screw ISO 4762 M6x20
- 2 EXCT-15 for screw ISO 4762 M6
EXCT-30/-100 for screw ISO 4762 M8

Dimensions and ordering data											
For size	B1	B2	B3	D2	H1	H2	H3	H4	H5	H6	H7
15	24	20	17	5	320	280	200	–	80	30	60
30	24	20	–	8	470	430	320	300	130	40	85
100	24	20	–	8	470	430	320	300	160	40	100

For size	L1	L2	L3	L4	L5	Weight [g]	Part No.	Type
15	80	30	60	55	45	1150	3995047	EAHM-E17-K1-15
30	100	35	60	70	–	2350	3823208	EAHM-E17-K1-30
100	100	35	60	70	–	2350	4055845	EAHM-E17-K1-100

Linear gantries EXCT

Accessories



Mounting kit EAHM-E17-K2

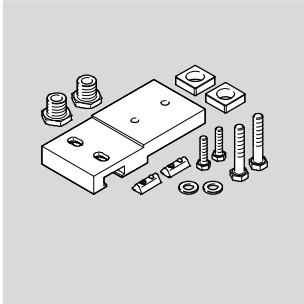

For mounting and aligning on a bearing surface.
The kit is height-adjustable

Materials:
Galvanised steel

EXCT-15

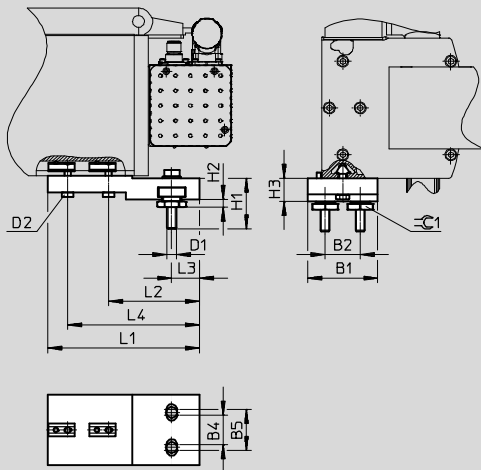

EXCT-30/-100

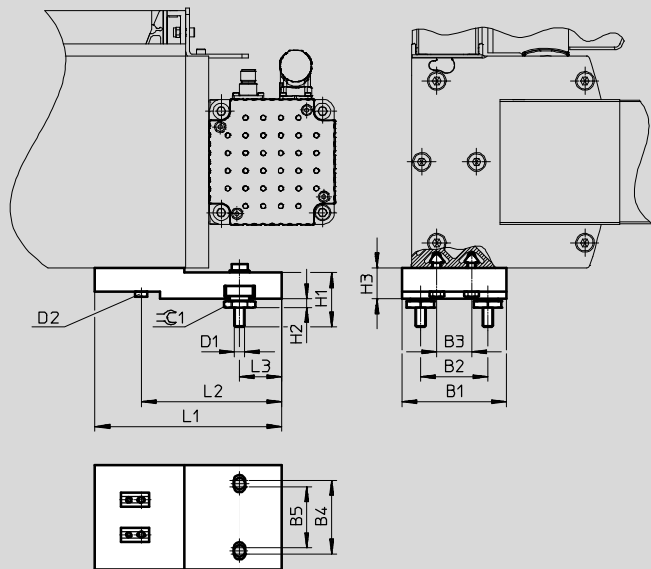

Dimensions and ordering data

For size	B1	B2	B3	B4	B5	D1	D2	H1	H2 +3	H3
15	60	30	–	25	35	M8	M6	43.4	6.8	20
30	84	54	28	49	59	M8	M6	43.4	6.8	25
100	110	70	50	65	75	M8	M6	43.4	6.8	25

For size	L1	L2	L3	L4	∅1	Weight [g]	Part No.	Type
15	130	78	24	113	22	1015	3838164	EAHM-E17-K2-15
30	150	113	34	–	22	2050	3838337	EAHM-E17-K2-30
100	170	133	29	–	22	3000	3838404	EAHM-E17-K2-100

Linear gantries EXCT

Accessories



Sensing kit EAPR-E17-S

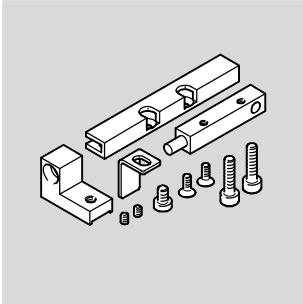

Included in the scope of delivery:
proximity sensor SIES-Q8B, sensor
bracket, switch lug, mounting bracket
and screws

Materials:
Switch lug: Steel
Sensor bracket: Wrought aluminium
alloy

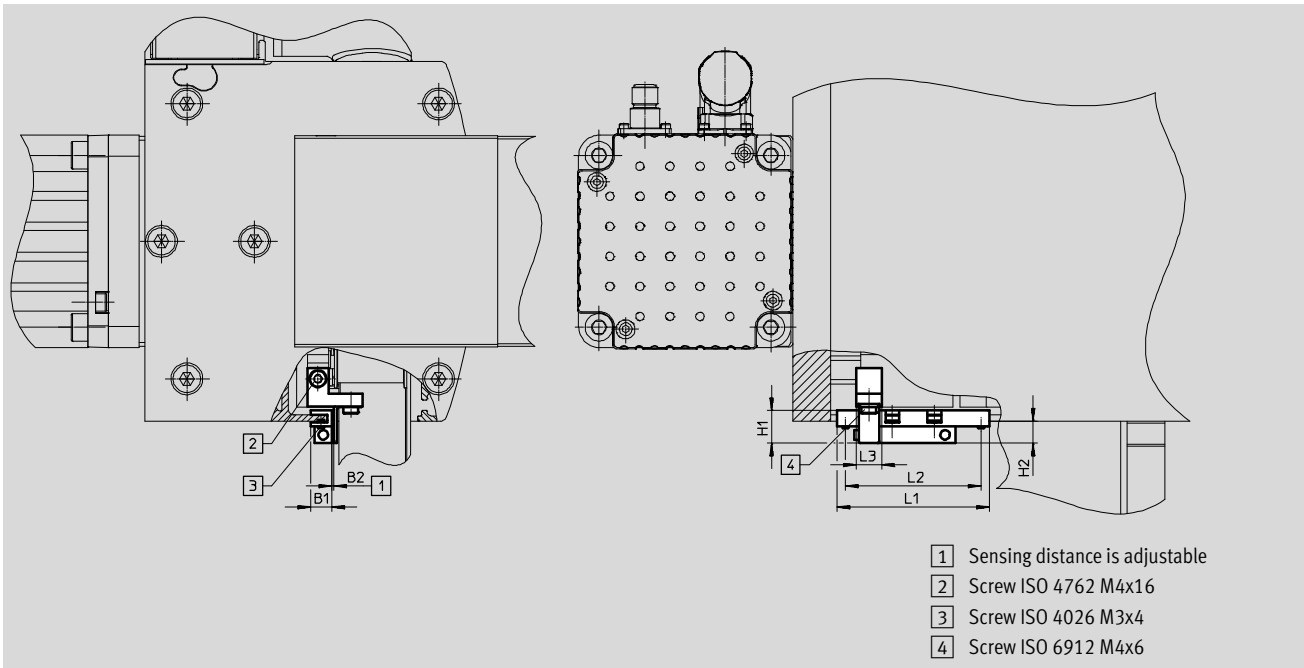

Dimensions and ordering data										
For size	B1	B2	H1	H2	L1	L2	L3	Weight [g]	Part No.	Type
15, 30, 100	10	1	15.5	10.5	72	64	12	30	2478427	EAPR-E17-S

Linear gantries EXCT

Accessories

Multi-pin plug set

EADH-E17

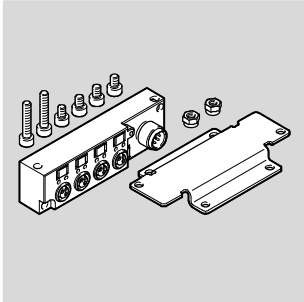

For connecting up to 4 inputs/outputs

Materials:

Housing: PBT reinforced

Bracket: aluminium

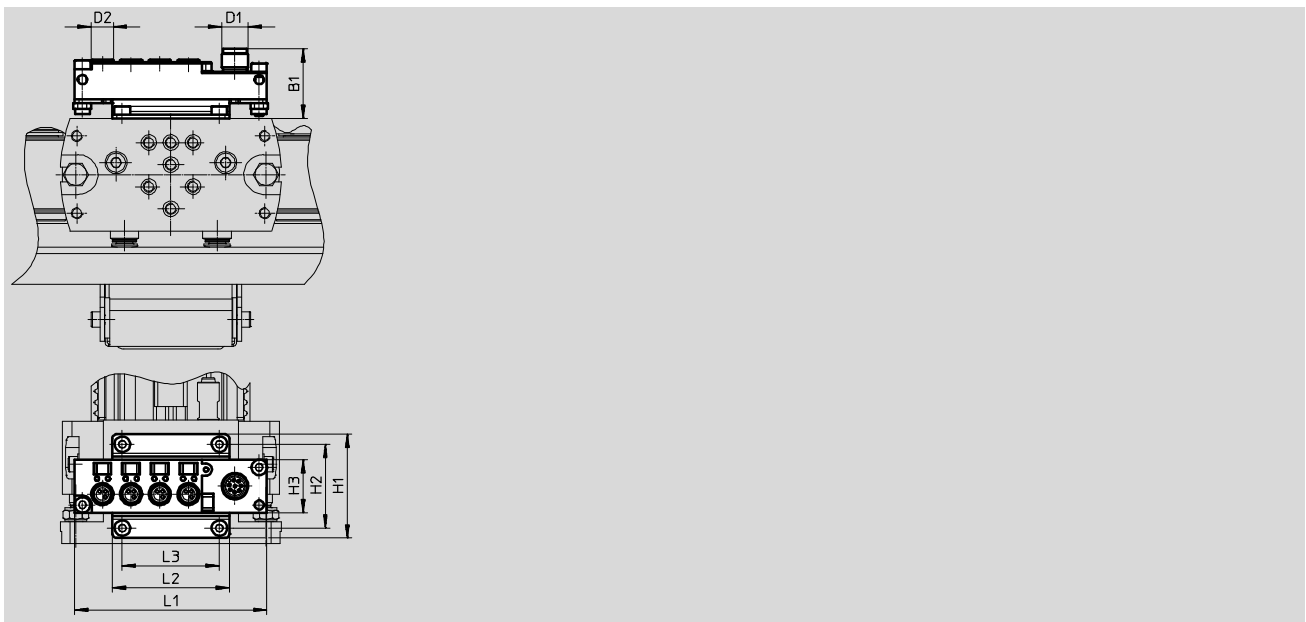

Dimensions and ordering data												
For size	B1	D1	D2	H1	H2	H3	L1	L2	L3	Weight [g]	Part No.	Type
15, 30, 100	31.5	M12	M8	47	38	24	87	53	44	70	2972137	EADH-E17-MP1

Linear gantries EXCT

Accessories



Adapter kit EAHM-E17

For mounting e.g. valves, vacuum generators etc. on the Z-axis

Materials:
Stainless steel

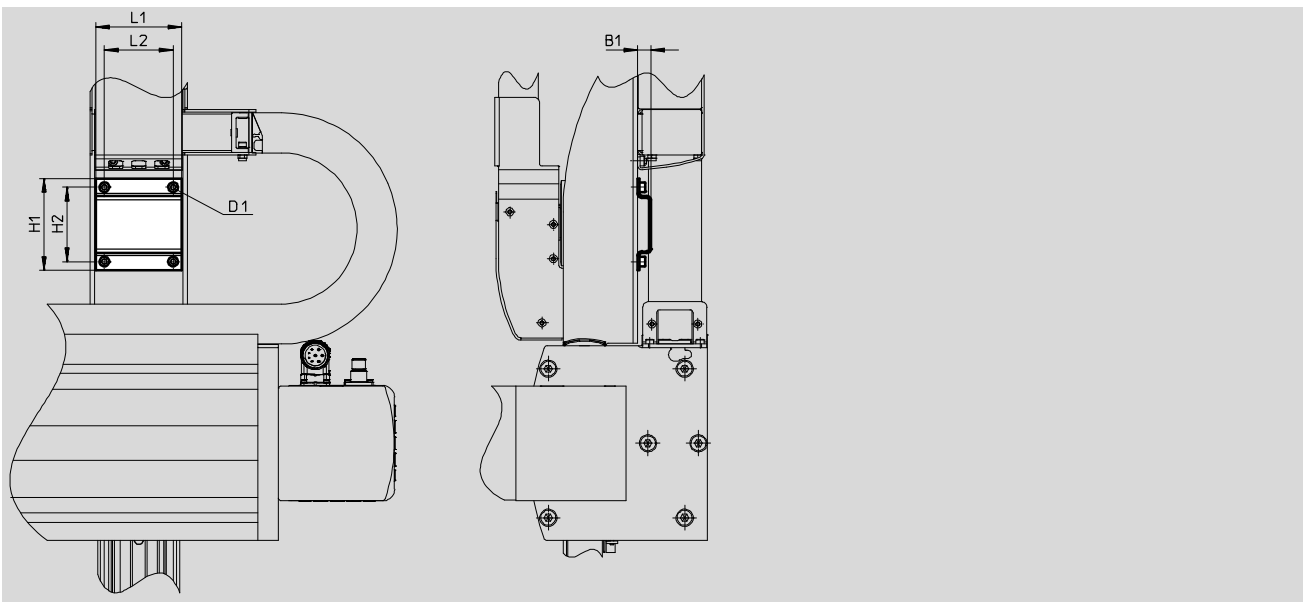
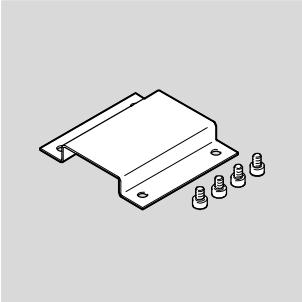

Dimensions and ordering data

For size	B1	D1	H1	H2	L1	L2	Weight [g]	Part No.	Type
15	11.5	M4x6	70	55	65	50	50	3018429	EAHM-E17-U-15
30	11.5	M5x8	80	65	75	60	95	3018428	EAHM-E17-U-30
100	11.5	M5x8	80	65	85	60	110	3018426	EAHM-E17-U-100

Linear gantries EXCT

Accessories

FESTO

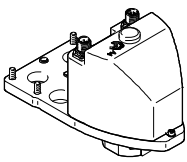
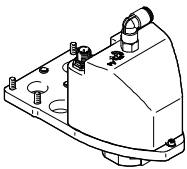
Ordering data – Front unit (rotary drive) ¹⁾					Download CAD data → www.festo.com	
	Description	For size	Order code	Part No.	Type	
	Without pneumatic rotary through-feed	15	T1	3383157	ERMH-8-E17-15	
		30	T1	3385151	ERMH-8-E17-30	
		30	T3	3385153	ERMH-11-E17-30	
		100	T3	3383152	ERMH-11-E17-100	
	With pneumatic rotary through-feed	15	T2	3383151	ERMH-8-P-E17-15	
		30	T2	3385152	ERMH-8-P-E17-30	
		30	T4	3385154	ERMH-11-P-E17-30	
		100	T4	3383156	ERMH-11-P-E17-100	

1) Included in the scope of delivery: motor cable, encoder cable and reference switch

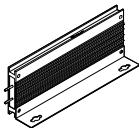
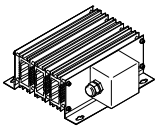
Ordering data – Braking resistor						
	For size	Resistance value [Ω]	Nominal power [W]	Weight [g]	Part No.	Type
	15	50	200	550	2882342	CACR-LE2-50-W500
	30, 100	40	800	2400	2882343	CACR-KL2-40-W2000

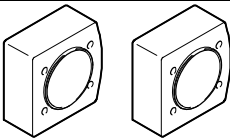
Ordering data							
	Description	For size	Possible screws	Tightening torque [Nm]	Part No.	Type	PU ¹⁾
Plug socket with cable NEBU for multi-pin plug set EADH							
	–	15, 30, 100	–	–	8048086	NEBU-M12W8-K-15-N-LE8	1
Coupling housing EAMK-A-E17 ²⁾							
	For connecting third-party motors	15	ISO 4762-M5xn ³⁾	6	3780303	EAMK-A-E17-15	2
		30	ISO 4762-M6xn ³⁾	8.5	3780304	EAMK-A-E17-30	
		100	ISO 4762-M6xn ³⁾	8.5	3780305	EAMK-A-E17-100	

1) Packaging unit quantity

2) Mounting screws are not included in the scope of delivery

3) The length n must be determined as a function of the motor flange used

Linear gantries EXCT

Accessories

FESTO

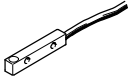
Ordering data					
	Switching output	Switching element function	Cable length [m]	Part No.	Type
Proximity sensor for sensing kit EAPR-E17					
	PNP	N/O contact	2.5	178294	SIES-Q8B-PS-K-L

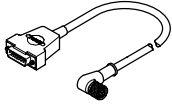
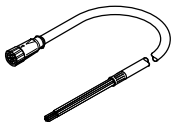
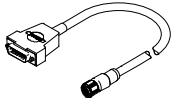
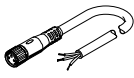
Ordering data – Cables					
	Cable length [m]		Part No.	Type	
For Y-axis					
	Motor cable NEBM				
	5		550310	NEBM-M23G8-E-5-Q9N-LE8	
	10		550311	NEBM-M23G8-E-10-Q9N-LE8	
	15		550312	NEBM-M23G8-E-15-Q9N-LE8	
	Encoder cable NEBM				
	5		550318	NEBM-M12W8-E-5-N-S1G15	
	10		550319	NEBM-M12W8-E-10-N-S1G15	
	15		550320	NEBM-M12W8-E-15-N-S1G15	
For front unit					
	Motor cable NEBM				
	15		571907	NEBM-M12G4-RS-15-N-LE4	
	Encoder cable NEBM				
	15		571915	NEBM-M12G12-RS-15-N-S1G15	
For reference switch for front unit					
	Connecting cable NEBU				
	15		575986	NEBU-M8G3-K-15-LE3	

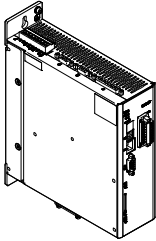
Ordering data – Motor controller						
	For size	Output voltage [V AC]	Nominal output current [A]	Nominal power [VA]	Part No.	Type
	For linear gantry					
	15	3x 0 ... 270	5	1000	1622902	CMMP-AS-C5-3A-M0
	30, 100	3x 0 ... 360	5	3000	1622903	CMMP-AS-C5-11A-P3-M0
	For attachment components					
	15, 30, 100	3x 0 ... 270	2.5	500	1622901	CMMP-AS-C2-3A-M0

Linear gantries EXCT

Accessories

FESTO

Permissible combinations without front unit

Download CAD data → www.festo.com

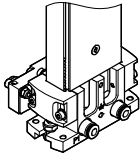

Combination with	Linear gantry	Drive/gripper	Adapter kit	
	Size	Size	CRC ¹⁾	Part No. Type
Semi-rotary drive				
DRRD	EXCT	DRRD	DHAA	
	15	10	2	2728486 DHAA-D-E8-45-Q11-10
	15, 30	12		2715152 DHAA-D-E8-45/55-Q11-12
	30	16		1926914 DHAA-D-E8-55-Q11-16
	100	16		1928306 DHAA-D-E8-75-Q11-16
	100	20		1930038 DHAA-D-E8-75-Q11-20
Parallel gripper				
DHPS	EXCT	DHPS	HMSV	
	15, 30	16	2	548785 HMSV-55
	100	20, 25		548786 HMSV-56
HGPD, sealed	EXCT	HGPD	DHAA, HAPG	
	15, 30	25	2	564952 DHAA-G-G6-16-B8-25
	100	25, 35		537175 HAPG-79
	100	40		564951 DHAA-G-G6-20-B8-40
HGPL, heavy-duty with long stroke	EXCT	HGPL	DHAA/HAPG	
	15, 30	14-20	2	2406159 DHAA-G-G6-16-B6-14
	100	14-20		2410181 DHAA-G-G6-20-B6-14
	15, 30	14-40, 14-60, 14-80		538055 HAPG-89
	100	14-40, 14-60, 14-80		539274 HAPG-90
	100	25		539274 HAPG-90
HGPP, precision	EXCT	HGPP	HAPG, HMSV	
	15, 30	10	2	529018 HAPG-58
	15, 30	12		191266 HAPG-48
	100	12		191267 HAPG-49
	100	16		191269 HAPG-51
HGPT-B, heavy-duty	EXCT	HGPT-B	DHAA, HAPG	
	15, 30	25	2	564952 DHAA-G-G6-16-B8-25
	100	40		564951 DHAA-G-G6-20-B8-40
	100	25, 35		537175 HAPG-79
HGPLE, electric	EXCT	HGPLE	DHAA	
	15, 30	14	2	2519367 DHAA-G-G6-16-B17-14
	100	14		2515219 DHAA-G-G6-20-B17-14

1) Corrosion resistance class CRC 2 to Festo standard FN 940070

Moderate corrosion stress. Indoor applications in which condensation may occur. External visible parts with primarily decorative requirements for the surface and which are in direct contact with the ambient atmosphere typical for industrial applications.

Linear gantries EXCT





Accessories

FESTO

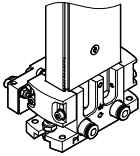
Permissible combinations without front unit

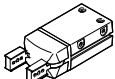
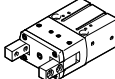
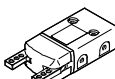
Download CAD data → www.festo.com



Combination with	Linear gantry	Drive/gripper	Adapter kit		
	Size	Size	CRC ¹⁾	Part No.	Type
Radial gripper					
DHRS	EXCT	DHRS	HMSV		
	15, 30	16	2	548785	HMSV-55
	100	25, 32		548786	HMSV-56
HGRT, heavy-duty	EXCT	HGRT	DHAA		
	15, 30	20	2	1278364	DHAA-G-G6-12-B11-20
	15, 30	25		1279418	DHAA-G-E8-45-B11-25
	100	25		1468307	DHAA-G-G6-20-B11-25
	100	32		1280494	DHAA-G-G6-25-B11-32
Angle gripper					
DHWS	EXCT	DHWS	HMSV		
	15, 30	16	2	548785	HMSV-55
	100	25, 32		548786	HMSV-56
Three-point gripper					
HGDD, sealed	EXCT	HGDD	DHAA		
	15, 30, 100	35	2	2371422	DHAA-G-G3-20-B13-35
	100	40		2373773	DHAA-G-H2-16-B13-40
	100	50		2377625	DHAA-G-H2-20-B13-50
	EXCT	HGDD-G1/G2	DHAA/HAPG		
	15, 30, 100	35	2	542436	HAPG-94
	100	40		542437	HAPG-95
	100	50		2378415	DHAA-G-H2-20-B13G-50
HGDT, heavy-duty	EXCT	HGDT	HAPG		
	15, 30	25	2	542439	HAPG-SD2-32
	15, 30, 100	35		542436	HAPG-94
	100	40		542437	HAPG-95
	100	50		542443	HAPG-SD2-36

1) Corrosion resistance class CRC 2 to Festo standard FN 940070
Moderate corrosion stress. Indoor applications in which condensation may occur. External visible parts with primarily decorative requirements for the surface and which are in direct contact with the ambient atmosphere typical for industrial applications.

Linear gantries EXCT

Accessories

FESTO

Permissible combinations with front unit (EXCT-...-T1/T2/T3/T4)

Download CAD data → www.festo.com

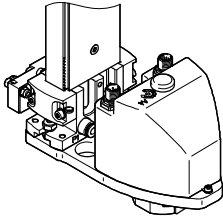

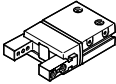
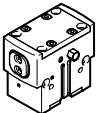
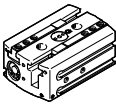
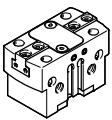
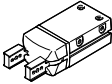
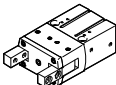
Combination with	Linear gantry	Drive/gripper	Adapter kit		
	Size	Size	CRC ¹⁾	Part No.	Type
Parallel gripper					
DHPS	EXCT with ERMH	DHPS	HMSV		
	15, 30, 100	6	2	187566	HAPG-SD2-12
		10		184477	HAPG-SD2-1
		16		184478	HAPG-SD2-2
HGPD, sealed	EXCT with ERMH	HGPD	DHAA, HAPG		
	15, 30, 100	16, 20	2	564959	DHAA-G-Q5-16-B8-16
		25		544642	HAPG-SD2-48
HGPL, heavy-duty with long stroke	EXCT with ERMH	HGPL	DHAA/HAPG		
	15, 30, 100	14	2	544644	HAPG-SD2-45
HGPT-B, heavy-duty	EXCT with ERMH	HGPT-B	DHAA, HAPG		
	15, 30, 100	16, 20	2	564959	DHAA-G-Q5-16-B8-16
		25		544642	HAPG-SD2-48
Radial gripper					
DHRS	EXCT with ERMH	DHRS	HMSV		
	15, 30, 100	10	2	187566	HAPG-SD2-12
		16		184477	HAPG-SD2-1
		25		184478	HAPG-SD2-2
HGRT, heavy-duty	EXCT with ERMH	HGRT	DHAA		
	15, 30, 100	16	2	1273999	DHAA-G-Q5-16-B11-16

1) Corrosion resistance class CRC 2 to Festo standard FN 940070

Moderate corrosion stress. Indoor applications in which condensation may occur. External visible parts with primarily decorative requirements for the surface and which are in direct contact with the ambient atmosphere typical for industrial applications.

Linear gantries EXCT

Accessories

FESTO

Permissible combinations with front unit (EXCT-...-T1/T2/T3/T4)

Download CAD data → www.festo.com

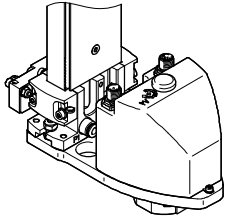

Combination with	Linear gantry	Drive/gripper	Adapter kit		
	Size	Size	CRC ¹⁾	Part No.	Type
Angle gripper					
DHWS	EXCT with ERMH	DHWS	HMSV		
	15, 30, 100	10	2	187566	HAPG-SD2-12
		16		184477	HAPG-SD2-1
		25		184478	HAPG-SD2-2
Three-point gripper					
DHDS	EXCT with ERMH	DHDS	HAPG		
	15, 30, 100	16	2	187567	HAPG-SD2-13
HGDT, heavy-duty	EXCT with ERMH	HGDT	HAPG		
	15, 30, 100	25	2	542439	HAPG-SD2-32

1) Corrosion resistance class CRC 2 to Festo standard FN 940070
 Moderate corrosion stress. Indoor applications in which condensation may occur. External visible parts with primarily decorative requirements for the surface and which are in direct contact with the ambient atmosphere typical for industrial applications.