

Toothed belt axes ELGR



Electromechanical drives

Selection aid



Overview of toothed belt and spindle axes

Toothed belt axes

- Speeds of up to 10 m/s
- Acceleration of up to 50 m/s²
- Repetition accuracy of up to ±0.08 mm
- Strokes of up to 8500 mm (longer strokes on request)
- Flexible motor mounting

Spindle axes

- Speeds of up to 2 m/s
- Acceleration of up to 20 m/s²
- Repetition accuracy of up to ±0.003 mm
- Strokes of up to 3000 mm

Coordinate system

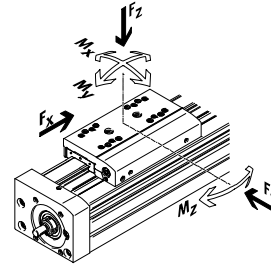

Toothed belt axes

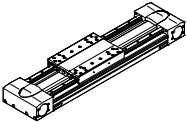
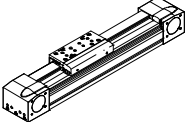
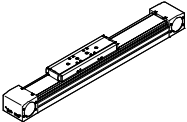
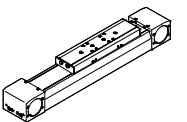
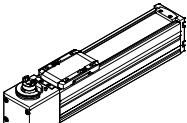
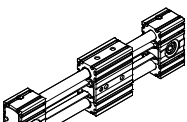
Type	F_x [N]	v [m/s]	M_x [Nm]	M_y [Nm]	M_z [Nm]	Key features
Heavy-duty recirculating ball bearing guide						
EGC-HD-TB						
	450 1000 1800	3 5 5	140 300 900	275 500 1450	275 500 1450	<ul style="list-style-type: none"> • Flat drive unit with rigid, closed profile • Precision DUO guide rail with high load capacity • Ideal as a basic axis for linear gantries and cantilever axes
Recirculating ball bearing guide						
EGC-TB-KF						
	50 100 350 800 2500	3 5 5 5 5	3.5 16 36 144 529	10 132 228 680 1820	10 132 228 680 1820	<ul style="list-style-type: none"> • Rigid, closed profile • Precision guide rail with high load capacity • Small drive pinions reduce required driving torque • Space-saving position sensing
ELGA-TB-KF						
	350 800 1300 2000	5 5 5 5	16 36 104 167	132 228 680 1150	132 228 680 1150	<ul style="list-style-type: none"> • Internal guide and toothed belt • Precision guide rail with high load capacity • Guide and toothed belt protected by cover strip • High feed forces
ELGA-TB-KF-F1						
	260 600 1000	5 5 5	16 36 104	132 228 680	132 228 680	<ul style="list-style-type: none"> • Suitable for use in the food zone • "Clean Look": smooth, easy to clean surfaces • Internal guide and toothed belt • Precision guide rail with high load capacity • Guide and toothed belt protected by cover strip
ELGC-TB-KF						
	75 120 250	1.2 1.5 1.5	5.5 29.1 59.8	4.7 31.8 56.2	4.7 31.8 56.2	<ul style="list-style-type: none"> • Internal guide and toothed belt • Precision guide rail with high load capacity • Guide and toothed belt protected by cover strip
ELGR-TB						
	50 100 350	3 3 3	2.5 5 15	20 40 124	20 40 124	<ul style="list-style-type: none"> • Cost-optimised rod guide • Ready-to-install unit • Ball bearings with high load capacity for dynamic operation

Electromechanical drives

Selection aid

Overview of toothed belt and spindle axes

Toothed belt axes

- Speeds of up to 10 m/s
- Acceleration of up to 50 m/s²
- Repetition accuracy of up to ±0.08 mm
- Strokes of up to 8500 mm (longer strokes on request)
- Flexible motor mounting

Spindle axes

- Speeds of up to 2 m/s
- Acceleration of up to 20 m/s²
- Repetition accuracy of up to ±0.003 mm
- Strokes of up to 3000 mm

Coordinate system

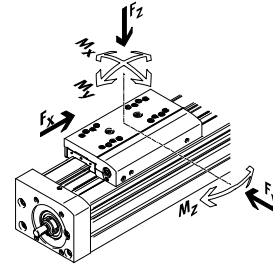

Toothed belt axes

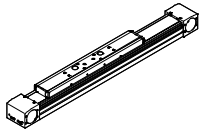
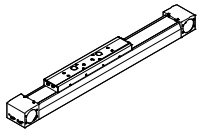
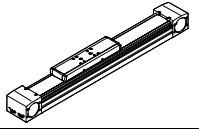
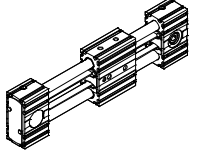
Type	F_x [N]	v [m/s]	M_x [Nm]	M_y [Nm]	M_z [Nm]	Key features
Roller bearing guide						
ELGA-TB-RF						
	350 800 1300	10 10 10	11 30 100	40 180 640	40 180 640	<ul style="list-style-type: none"> • Heavy-duty roller bearing guide • Guide and toothed belt protected by cover strip • Speeds of up to 10 m/s • Lower weight than axes with guide rails
ELGA-TB-RF-F1						
	260 600 1000	10 10 10	8.8 24 80	32 144 512	32 144 512	<ul style="list-style-type: none"> • Suitable for use in the food zone • "Clean Look": smooth, easy to clean surfaces • Heavy-duty roller bearing guide • Guide and toothed belt protected by cover strip • Lower weight than axes with guide rails
Plain-bearing guide						
ELGA-TB-G						
	350 800 1300	5 5 5	5 10 120	30 60 120	10 20 40	<ul style="list-style-type: none"> • Guide and toothed belt protected by cover strip • For simple handling tasks • As a drive component for external guides • Insensitive to harsh operating conditions
ELGR-TB-GF						
	50 100 350	1 1 1	1 2.5 1	10 20 40	10 20 40	<ul style="list-style-type: none"> • Cost-optimised rod guide • Ready-to-install unit • Heavy-duty plain bearings for use in harsh operating conditions

Electromechanical drives

Selection aid



Overview of toothed belt and spindle axes

Toothed belt axes

- Speeds of up to 10 m/s
- Acceleration of up to 50 m/s²
- Repetition accuracy of up to ±0.08 mm
- Strokes of up to 8500 mm (longer strokes on request)
- Flexible motor mounting

Spindle axes

- Speeds of up to 2 m/s
- Acceleration of up to 20 m/s²
- Repetition accuracy of up to ±0.003 mm
- Strokes of up to 3000 mm

Coordinate system

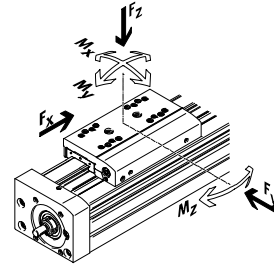

Spindle axes

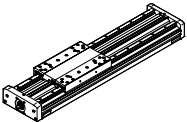
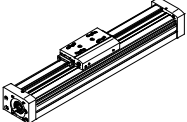
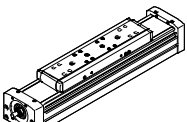
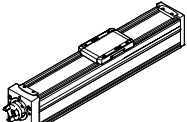
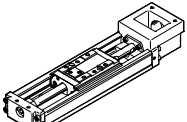
Type	F_x [N]	v [m/s]	M_x [Nm]	M_y [Nm]	M_z [Nm]	Key features
Heavy-duty recirculating ball bearing guide						
EGC-HD-BS						
	300 600 1300	0.5 1.0 1.5	140 300 900	275 500 1450	275 500 1450	<ul style="list-style-type: none"> • Flat drive unit with rigid, closed profile • Precision DUO guide rail with high load capacity • Ideal as a basic axis for linear gantries and cantilever axes
Recirculating ball bearing guide						
EGC-BS-KF						
	300 600 1300 3000	0.5 1.0 1.5 2.0	16 36 144 529	132 228 680 1820	132 228 680 1820	<ul style="list-style-type: none"> • Rigid, closed profile • Precision guide rail with high load capacity • For the highest requirements in terms of feed force and accuracy • Space-saving position sensing
ELGA-BS-KF						
	300 600 1300 3000	0.5 1.0 1.5 2.0	16 36 104 167	132 228 680 1150	132 228 680 1150	<ul style="list-style-type: none"> • Internal guide and ball screw • Precision guide rail with high load capacity • For the highest requirements in terms of feed force and accuracy • Guide and ball screw protected by cover strip • Space-saving position sensing
ELGC-BS-KF						
	40 100 200 350	0.6 0.6 0.8 1.0	1.3 5.5 29.1 59.8	1.1 4.7 31.8 56.2	1.1 4.7 31.8 56.2	<ul style="list-style-type: none"> • Internal guide and ball screw • Guide and ball screw protected by cover strip • Space-saving position sensing
EGSK						
	57 133 184 239 392	0.33 1.10 0.83 1.10 1.48	13 28.7 60 79.5 231	3.7 9.2 20.4 26 77.3	3.7 9.2 20.4 26 77.3	<ul style="list-style-type: none"> • Spindle axes with maximum precision, compactness and rigidity • Recirculating ball bearing guide and ball screw without caged ball bearings • Standard designs in stock

Toothed belt axes ELGR

Key features

At a glance		
General	Properties	Range of applications
<ul style="list-style-type: none"> • Optimum price/performance ratio • Ready-to-install unit for quick and easy design • High reliability thanks to tested service life of 5000 km • Complete module for a simple and space-saving solution for end-position sensing 	<ul style="list-style-type: none"> • Plain-bearing guide <ul style="list-style-type: none"> – For small loads – Restricted operating behaviour with torque load – Not backlash-free guide 	<ul style="list-style-type: none"> • Recirculating ball bearing guide <ul style="list-style-type: none"> – For medium loads – Very good operating behaviour with torque load – Backlash-free guide (preloaded guide elements)
		<ul style="list-style-type: none"> • Pick & place with payloads of up to 15 kg • Positioning and handling with low process forces • Actuation of guard doors in processing machines

Modular axis system with open motor interface → page 9

- Variable strokes
- Two guide variants
- Axial kits for servo and stepper motors
- The motor position can be freely selected on 4 sides and can be changed at any time.



Optimised Motion Series (OMS) – Package solution with motor and motor controller → page 22

A package that makes positioning easier than ever before. The Optimised Motion Series is as easy to handle as a pneumatic cylinder, but with the functionality of an electric drive.



Simple choice	Ordering and logistics	Quick to configure
<ul style="list-style-type: none"> • Easy sizing and selection using cycle time charts • No specialist knowledge of electric drive technology required 	<ul style="list-style-type: none"> • All the necessary component parts with a single part number • Motors preassembled on the axis mechanism 	<ul style="list-style-type: none"> • Parameterisation and commissioning via web server/browser • Parameterise up to 7 freely definable positions directly on the PC



For simple positioning tasks

Toothed belt axis ELGR

Controller CMMO
→ Internet: cmmo



Toothed belt axes ELGR

Key features



Possible combinations within the Optimised Motion Series (OMS)

Electric cylinder EPCO on toothed belt axis ELGR

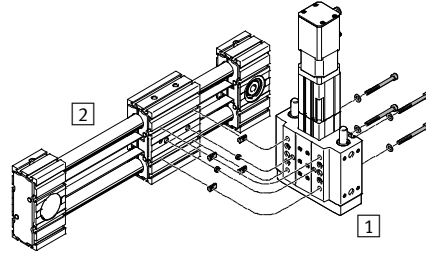
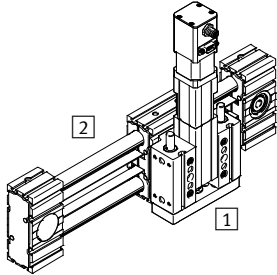

Size		Accessories			
1	2	Slot nut	Centring sleeve	Screw	Washer
EPCO	ELGR				
16	35	NST-3-M3 (x4)	ZBH-7 (x2)	M3x10 (x4)	–
25	45	NST-5-M5 (x4)	ZBH-7 (x2)	M5x50 (x4)	DIN125-A5.3 (x4)
40	55	NST-5-M5 (x4)	ZBH-7 (x2)	M5x65 (x4)	DIN125-A5.3 (x4)

Rotary drive ERMO on electric cylinder EPCO

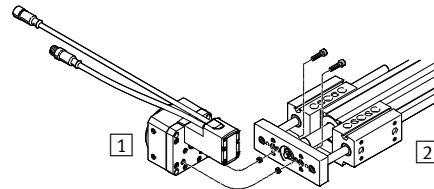
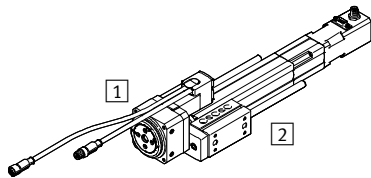

Size		Accessories	
1	2	Centring sleeve	Screw
ERMO	EPCO		
12	16	ZBH-7 (x2)	M4x16 (x2)
16	25	ZBH-7 (x2)	M5x18 (x2)
25	40	ZBH-7 (x2)	M5x20 (x2)

Rotary drive ERMO on mini slide DGSL

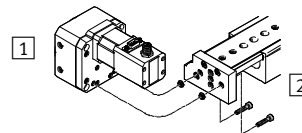
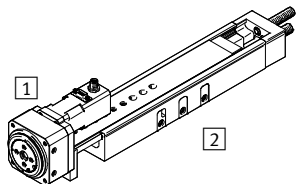

Size		Accessories	
1	2	Centring sleeve	Screw
ERMO	DGSL		
12	12	ZBH-7 (x2)	M4x18 (x2)
25	20	ZBH-9-7 (x2)	M5x22 (x2)
25	25	ZBH-9-7 (x2)	M5x22 (x2)

Rotary drive ERMO on mini slide EGSL

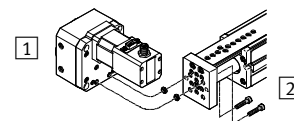
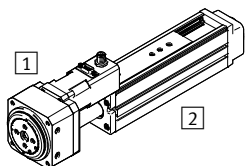

Size		Accessories	
1	2	Centring sleeve	Screw
ERMO	EGSL		
12	35	ZBH-7 (x2)	M4x12 (x2)
16	45	ZBH-7 (x2)	M5x12 (x2)
25	55	ZBH-7 (x2)	M5x14 (x2)
32	55	ZBH-7 (x2)	M5x14 (x2)

Toothed belt axes ELGR

Key features

Possible combinations within the Optimised Motion Series (OMS)

Electric cylinder EPCO on electric cylinder EPCO, horizontal

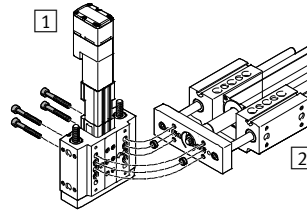
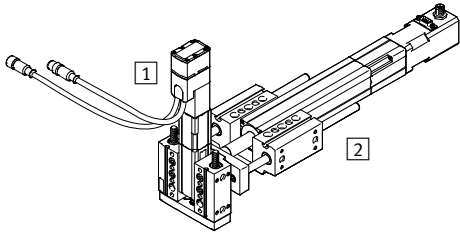

Size		Accessories	
1 EPCO	2 EPCO	Centring sleeve	Screw
16	25	ZBH-9 (x2)	M6x40 (x4)
25	40	ZBH-9 (x2)	M6x55 (x4)

Electric cylinder EPCO on electric cylinder EPCO, vertical

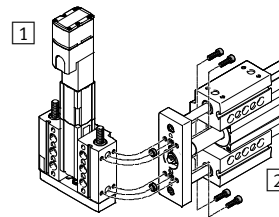
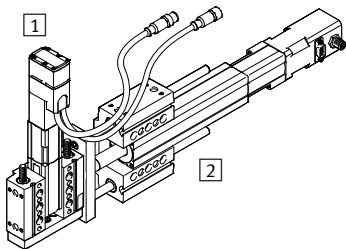

Size		Accessories	
1 EPCO	2 EPCO	Centring sleeve	Screw
16	25	ZBH-9 (x2)	M5x18 (x4)
25	40	ZBH-9 (x2)	M5x22 (x4)

Mini slide DGSL on electric cylinder EPCO

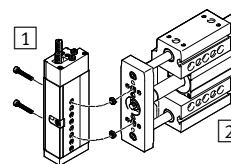
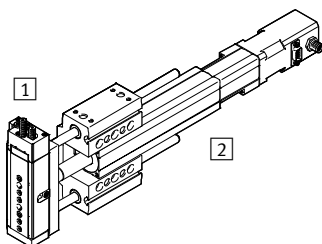

Size		Accessories	
1 DGSL	2 EPCO	Centring sleeve	Screw
8 (40mm) ¹⁾	16	ZBV-9-7 (x2)	M4x16 (x2)
10 (30mm) ¹⁾	25	ZBV-9-7 (x2)	M4x20 (x2)
12 (40mm) ¹⁾	40	ZBV-9-7 (x2)	M5x20 (x2)

1) Minimum stroke

Toothed belt axes ELGR

Key features

Characteristic values of the axes

The specifications shown in the table are maximum values.

The precise values for each of the variants can be found in the relevant technical data.

 Note

PositioningDrives
engineering software
www.festo.com

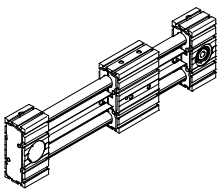
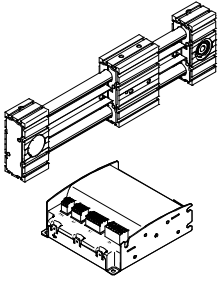
Design	Size	Working stroke [mm]	Speed [m/s]	Repetition accuracy [mm]	Feed force [N]	Guide characteristics					→ Page
						Forces and torques					
						Fy [N]	Fz [N]	Mx [Nm]	My [Nm]	Mz [Nm]	
Toothed belt axis ELGR											
	35	50 ... 800	3	±0.1	50	50	50	2.5	20	20	9
	45	50 ... 1000	3	±0.1	100	100	100	5	40	40	
	55	50 ... 1500	3	±0.1	350	300	300	15	124	124	
Toothed belt axis ELGR in combination with Optimised Motion series (OMS)											
	35	50 ... 800 ¹⁾	1.1	±0.1	50	20	20	2.5	20	20	22
	45	50 ... 1000 ¹⁾	1.1	±0.1	100	50	50	5	40	40	
	55	50 ... 1500 ¹⁾	0.35	±0.1	350	90	90	15	124	124	

1) Only standard strokes can be ordered → page 36

Toothed belt axes ELGR

Type codes

		ELGR	-	TB	-		-	45	-	500	-	30H	-	L	-	
Type																
ELGR	Linear axis															
Drive function																
TB	Toothed belt															
Guide																
-	Recirculating ball bearing guide															
GF	Plain-bearing guide															
Size																
Stroke [mm]																
Stroke reserve																
Slide																
-	Standard slide															
L	Long slide															
Additional slide																
-	No additional slide															
ZR	1 slide on right															
ZL	1 slide on left															
ZB	1 slide on right, 1 slide on left															

		→	+	2SA		4NM	EA	2MA	+	
Proximity sensor										
...SA	Proximity sensor (SIES), inductive, slot type 8, PNP, N/O contact, cable 7.5 m									
...SB	Proximity sensor (SIES), inductive, slot type 8, PNP, N/C contact, cable 7.5 m									
Cover										
...NC	For mounting slot									
Slot nut										
...NM	For mounting slot									
Drive shaft										
...EA	Drive shaft									
Profile mounting										
...MA	Profile mounting									
Operating instructions										
-	With operating instructions									
DN	Without operating instructions									

Toothed belt axes ELGR

Peripherals overview

FESTO

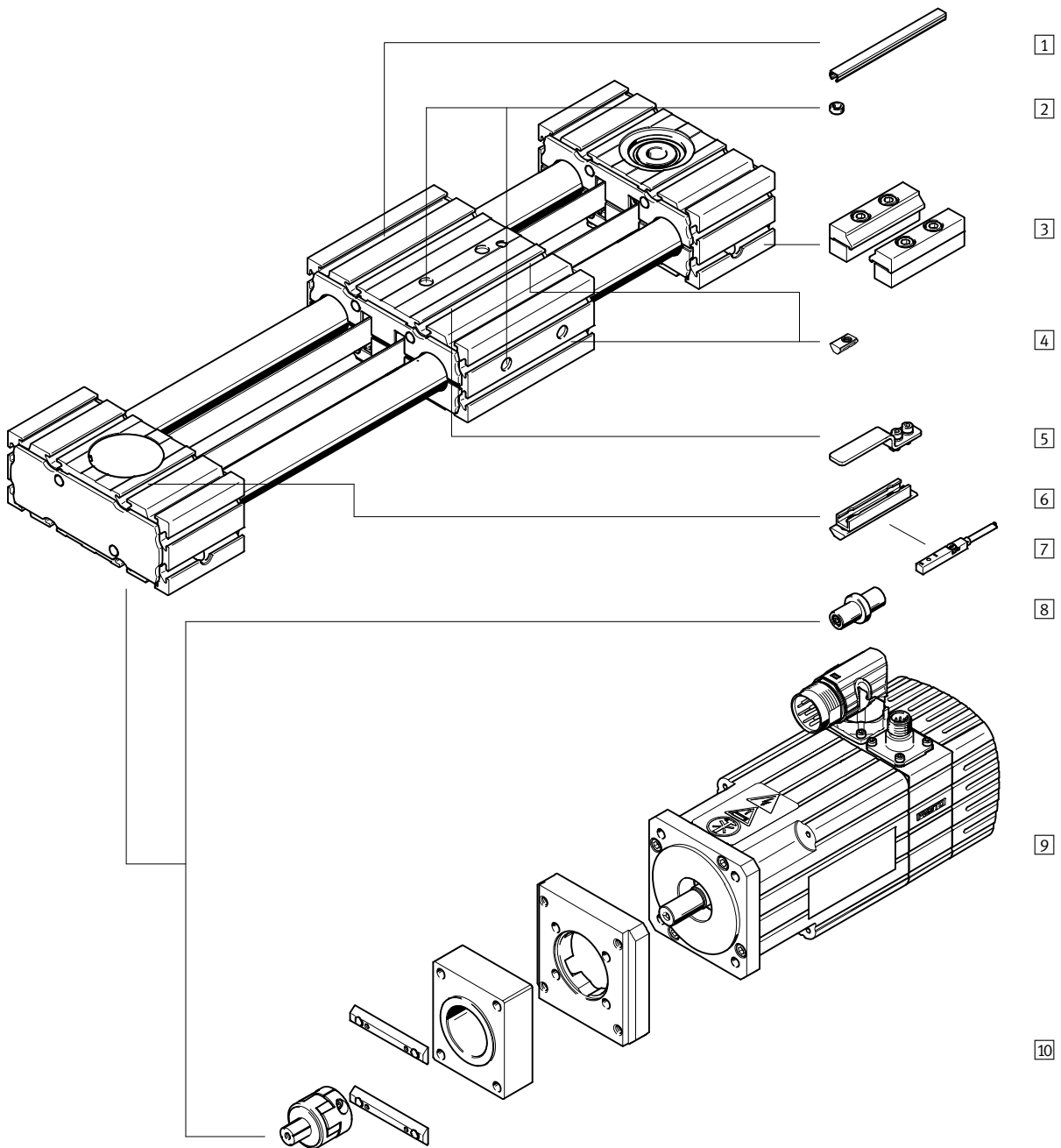

Toothed belt axes ELGR

Peripherals overview



Accessories			
	Type/order code	Description	→ Page/Internet
1	Slot cover NC	<ul style="list-style-type: none"> For protecting against ingress of dirt 	43
2	Centring sleeve ZBH	<ul style="list-style-type: none"> For centring loads and attachments on the slide 2 centring sleeves included in the scope of delivery of the axis 	43
3	Profile mounting MA	For mounting the axis on the bearing cap	42
4	Slot nut NM	For mounting attachments	43
5	Switch lug SA, SB	For sensing the slide position	42
6	Sensor bracket SA, SB	Adapter for mounting the inductive proximity sensors on the axis	42
7	Proximity sensor, T-slot SA, SB	<ul style="list-style-type: none"> Inductive proximity sensor, for T-slot 1 switching lug and 1 sensor bracket are included in the scope of delivery with the order code SA, SB 	44
8	Drive shaft EA	<ul style="list-style-type: none"> Can, if required, be used as an alternative interface No drive shaft is required for the axis/motor combinations → page 38 	43
9	Motor EMME, EMMS	Motors specially matched to the axis, with or without brake	38
10	Axial kit EAMM	For axial motor mounting (comprises: coupling, coupling housing and motor flange)	38
–	Connecting cable NEBU	For proximity sensor (order code SA and SB)	44

Toothed belt axes ELGR

Technical data

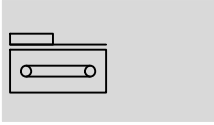
Function



-  Size
35 ... 55
-  Stroke length
50 ... 1500 mm
-  www.festo.com

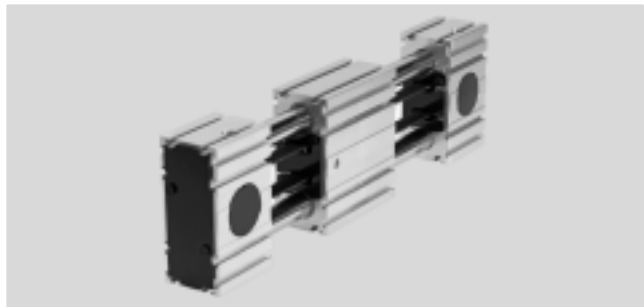

General technical data				
Size		35	45	55
Design		Electromechanical linear axis with toothed belt		
Guide		Recirculating ball bearing guide		
		Plain-bearing guide		
Mounting position		Any		
Working stroke	[mm]	50 ... 800	50 ... 1000	50 ... 1500
Max. feed force F_x	[N]	50	100	350
Max. no-load torque	[Nm]	0.1	0.2	0.4
Max. driving torque	[Nm]	0.46	1.24	5
Max. no-load resistance to shifting	[N]	10.8	16.1	27.9
Max. speed				
Recirculating ball bearing guide	[m/s]	3		
Plain-bearing guide	[m/s]	1		
Max. acceleration ¹⁾	[m/s ²]	50		
Repetition accuracy	[mm]	±0.1		

1) The max. acceleration is dependent on the payload, the driving torque and the max. feed force → page 15

Operating and environmental conditions			
Ambient temperature			
Recirculating ball bearing guide	[°C]	-10 ... +50	
Plain-bearing guide	[°C]	0 ... +40	
Degree of protection		IP20	
Duty cycle	[%]	100	

Weight [kg]				
Size		35	45	55
Recirculating ball bearing guide				
Basic weight with 0 mm stroke ¹⁾				
Standard slide		1.5	3.2	5.4
Long slide		1.9	4.3	7.4
Additional weight per 1000 mm stroke		2.5	5.0	7.8
Moving mass		0.5	1.1	1.9
Slide				
Standard slide		0.5	1.0	1.8
Long slide		0.8	1.7	3.0
Additional slide		0.4	0.9	1.7

1) Incl. slides

Toothed belt axes ELGR

Technical data

Weight [kg]			
Size	35	45	55
Plain-bearing guide			
Basic weight with 0 mm stroke ¹⁾			
Standard slide	1.4	3.1	5.1
Long slide	1.9	4.3	7.3
Additional weight per 1000 mm stroke	2.5	5.0	7.8
Moving mass	0.4	0.9	1.5
Slide			
Standard slide	0.4	0.9	1.5
Long slide	0.7	1.6	2.8
Additional slide	0.3	0.7	1.3

1) Incl. slides

Toothed belt			
Size	35	45	55
Pitch [mm]	2	3	3
Expansion ¹⁾ [%]	0.094	0.08	0.21
Width [mm]	10	15	19.3
Effective diameter [mm]	18.46	24.83	28.65
Feed constant [mm/rev]	58	78	90

1) At max. feed force

Mass moment of inertia			
Size	35	45	55
J_0			
Standard slide [kg mm ²]	40.26	155.13	360.48
Long slide [kg mm ²]	66.50	271.52	638.74
J_S per metre stroke [kg mm ² /m]	0.26	1.06	1.88
J_L per kg payload [kg mm ² /kg]	85.19	154.13	205.21
J_W Additional slide [kg mm ²]	36.75	136.55	301.92

The mass moment of inertia J_A of the entire axis is calculated as follows:

$$J_A = J_0 + K \times J_W + J_H \times \text{working stroke [m]} + J_L \times m_{\text{payload [kg]}}$$

K = Number of additional slides

Materials

Sectional view

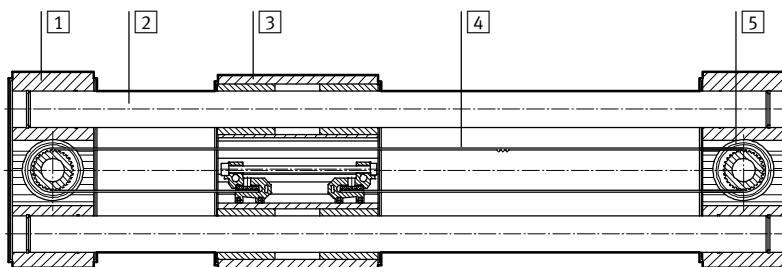

Axis		
1	Bearing cap, profile	Anodised wrought aluminium alloy
2	Guide rods	Tempered steel, hardened and hard-chromium plated
3	Slide, profile	Anodised wrought aluminium alloy
4	Toothed belt	Polychloroprene with glass cord and nylon coating
5	Belt pulley	High-alloy stainless steel
Note on materials		RoHS-compliant
		Contains paint-wetting impairment substances

Toothed belt axes ELGR

Technical data

Characteristic load values

The indicated forces and torques refer to the centre of the guide. The point of application of force is the point where the centre of the guide and the longitudinal centre of the slide intersect. These values must not be exceeded during dynamic operation. Special attention must be paid to the cushioning phase.

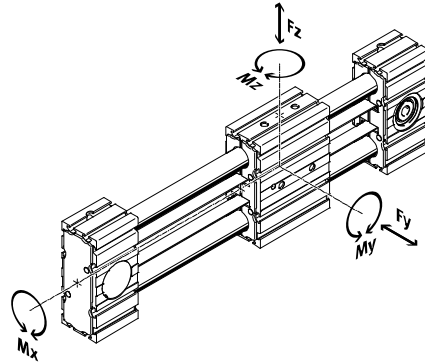

If the axis is subjected to two or more of the indicated forces and torques simultaneously, the following equation must be satisfied in addition to the indicated maximum loads:

Calculating the load comparison factor:

$$f_v = \frac{|F_{y,dyn}|}{F_{y,max}} + \frac{|F_{z,dyn}|}{F_{z,max}} + \frac{|M_{x,dyn}|}{M_{x,max}} + \frac{|M_{y,dyn}|}{M_{y,max}} + \frac{|M_{z,dyn}|}{M_{z,max}} \leq 1$$

Permissible forces and torques for a service life of 5000 km						
Guide	Plain-bearing guide			Recirculating ball bearing guide		
Size	35	45	55	35	45	55
$F_{y,max}, F_{z,max}$ [N]	50	100	300	50	100	300
Standard slide						
$M_{x,max}$ [Nm]	1	2.5	5	2.5	5	15
$M_{y,max}$ [Nm]	4	8	16	8	16	48
$M_{z,max}$ [Nm]	4	8	16	8	16	48
Long slide						
$M_{x,max}$ [Nm]	1	2.5	5	2.5	5	15
$M_{y,max}$ [Nm]	10	20	40	20	40	124
$M_{z,max}$ [Nm]	10	20	40	20	40	124

Service life

The service life of the guide depends on the load. To provide a rough indication of the service life of the guide,

the graph below plots the load comparison factor f_v against the service life.

These values are only theoretical. You must consult your local contact person at Festo for load comparison factors f_v greater than 1.5.

Load comparison factor f_v as a function of service life

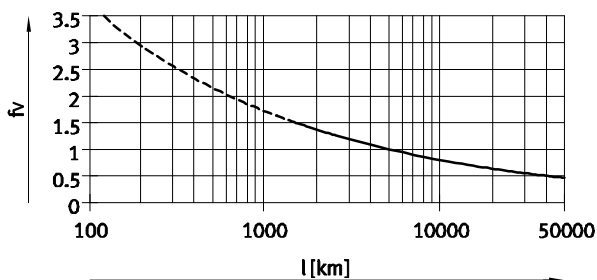

Example:

A user wants to move an X kg load. Using the above formula gives a value of 1.5 for the load comparison factor f_v . According to the graph, the guide would have a service life of

approx. 1500 km. Reducing the acceleration reduces the M_z and M_y values. A load comparison factor of 1 now gives a service life of 5000 km.

-  Note
PositioningDrives
engineering software
www.festo.com

Toothed belt axes ELGR

Technical data

Max. load with flat mounting position

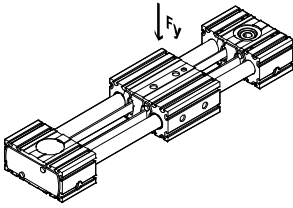

The characteristic curves in the graph correspond to the max. recommended deflection of 0.5 mm.

In this case, the axis can no longer support the maximum load past a certain stroke length.

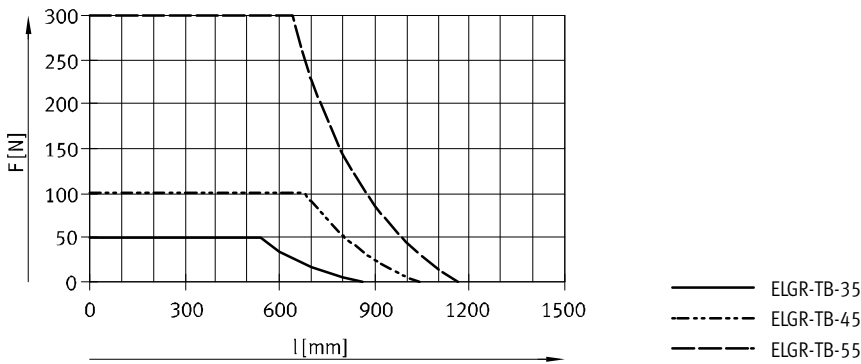

Maximum acceleration a as a function of the payload m

ELGR-35

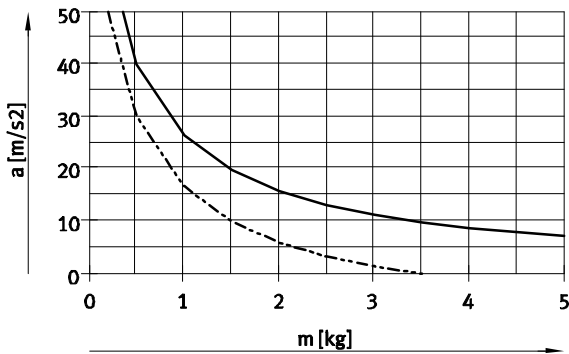

ELGR-45

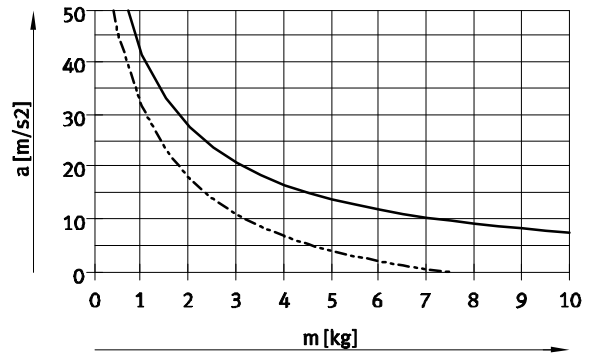

ELGR-55

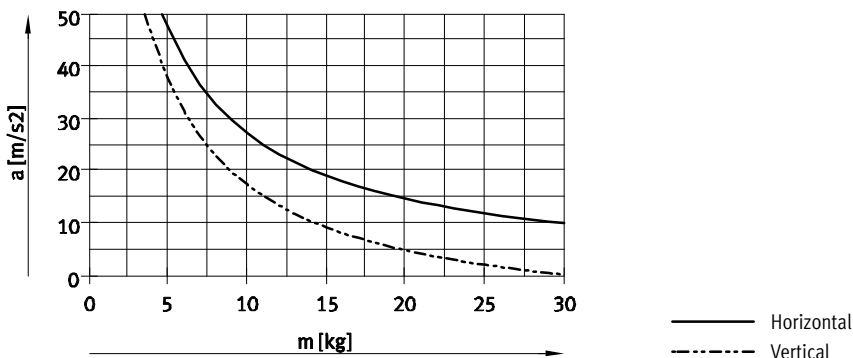

Toothed belt axes ELGR

Technical data

Feed force F_x as a function of input torque M

ELGR-35

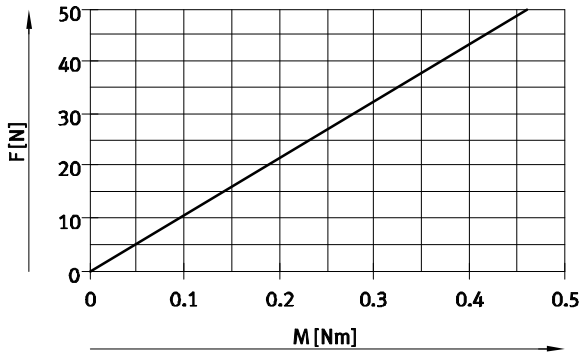

ELGR-45

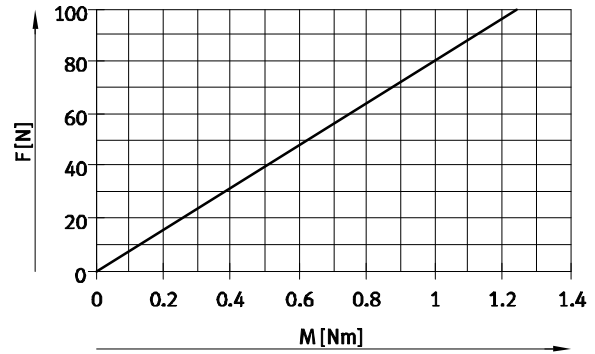

ELGR-55

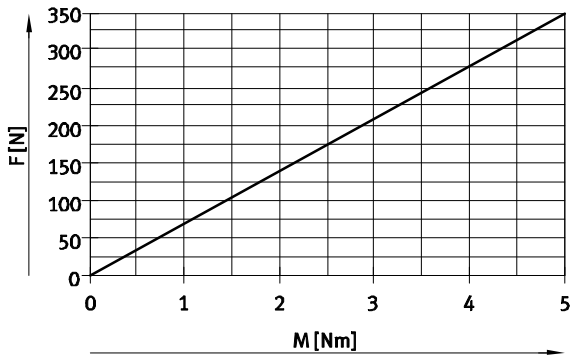

Speed v as a function of rotational speed n

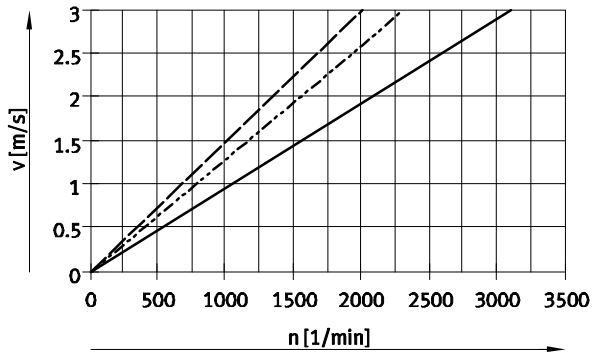

- ELGR-TB-35
- - - ELGR-TB-45
- · - ELGR-TB-55

Toothed belt axes ELGR

Technical data

FESTO

Minimum nominal stroke

for variants with additional slide ELGR-...-ZR/ZL/ZB

Size	35		45		55	
ELGR-	ZR/ZL	ZB	ZR/ZL	ZB	ZR/ZL	ZB
Min. nominal stroke [mm]	126	202	146	242	166	282

Stroke reserve



L18 = Nominal stroke

L19 = Stroke reserve

- The stroke reserve is a safety distance from the mechanical end position and is not used in normal operation
- The sum of the nominal stroke and 2x stroke reserve must not exceed the maximum permissible working stroke
- The stroke reserve length can be freely selected
- The stroke reserve is defined via the "stroke reserve" characteristic in the modular product system.

Example:

Type ELGR-TB-45-500-20H-...

Nominal stroke = 500 mm

2x stroke reserve = 40 mm

Working stroke = 540 mm

(540 mm = 500 mm + 2 x 20 mm)

Working stroke reduction

For standard slide or long slide with additional slide ELGR-...-ZR/ZL/ZB

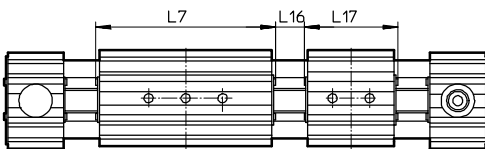

L7 = Slide length

L16 = Distance between the two slides

L17 = Additional slide length

- For a toothed belt axis with additional slide, the working stroke is reduced by the length of the additional slide and the distance between the two slides
- If the long slide variant L is ordered, the additional slide is not extended

Example:

Type ELGR-TB-35-500-...-ZR

Working stroke = 500 mm

L16 = 10 mm

L7, L17 = 76 mm

Working stroke with

additional slide = 414 mm

(500 mm - 10 mm - 76 mm)

Dimensions – Additional slide

Size	35	45	55
Length L17 [mm]	76	96	116
Distance between the slides L16 [mm]	≥ 0		

Second moment of area

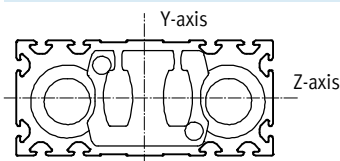

Size	35	45	55
I_y [mm ⁴]	4.19×10^3	17.95×10^3	41.18×10^3
I_z [mm ⁴]	3.77×10^3	15.71×10^3	38.35×10^3

Recommended deflection limits

Adherence to a maximum deflection of 0.5 mm is recommended so as not to impair the functional performance of the axes. Greater deformation can result in increased friction, greater wear and reduced service life.

Toothed belt axes ELGR

Technical data



Dimensions

Download CAD data → www.festo.com

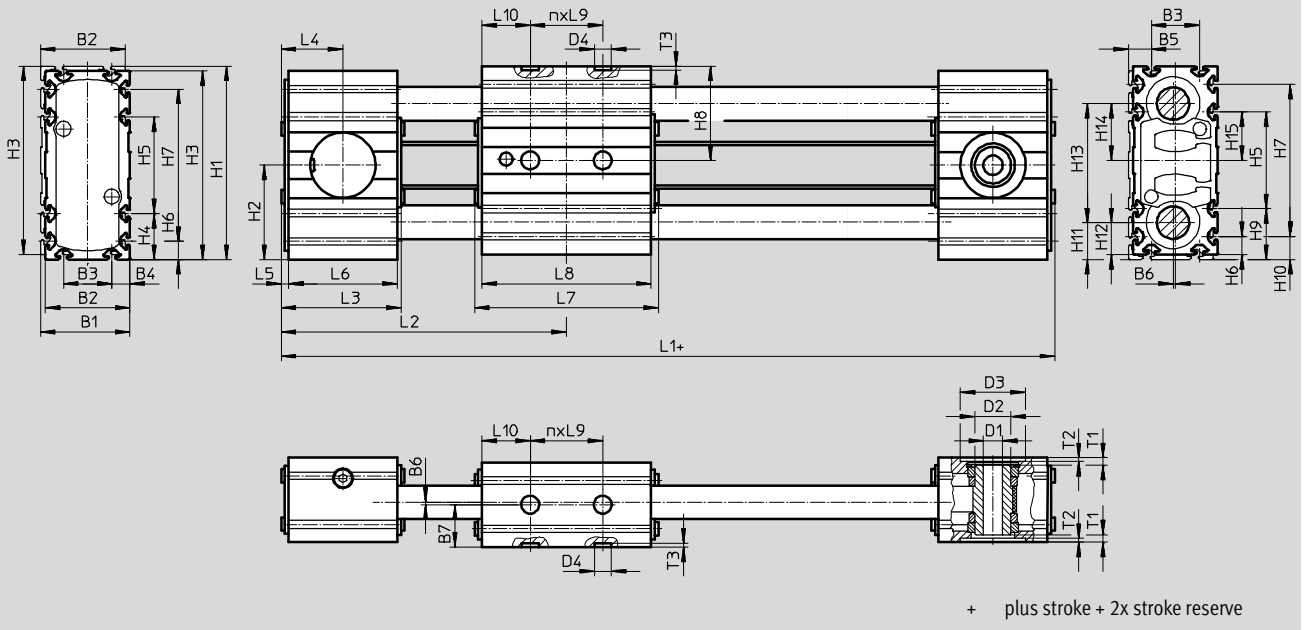

Profile

ELGR-35

ELGR-45

ELGR-55

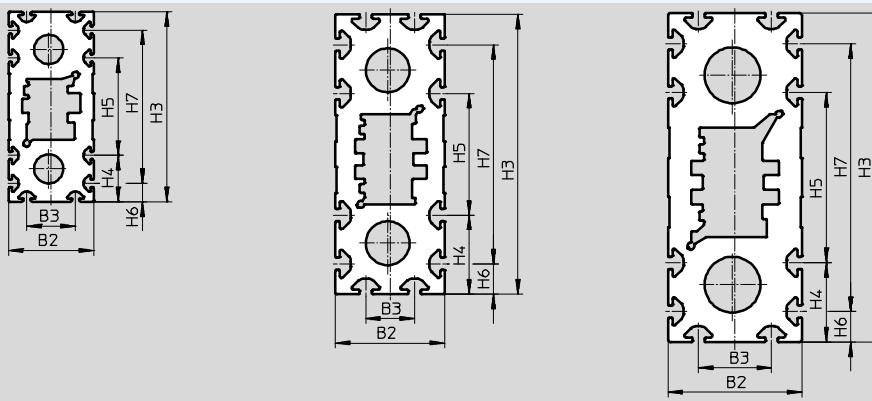

Size	B1	B2	B3	B4	B5	B6	B7	D1 ∅ H7	D2 ∅	D3 ∅ H7	D4 ∅ H7	H1	H2	H3	H4	H5	H6
35	37	35	20	7.5	9.5	1	17.5	8	15	27	7	80	39	78	19	40	7.5
45	47	45	20	12.5	14.5		22.5	10	20	38		117	57.5	115	32.5	50	12.5
55	57	55	30	12.5	14.5		27.5	16	25	48		137	67.5	135	32.5	70	12.5

Size	H7	H8	H9	H10	H11	H12	H13	H14	H15	L3	L4	L5	L6	L9	T1	T2	T3 +0.1
35	63	39	21	9.5	15.5	13.5	49	23.5	20	51	25.5	3	45	30	3.1	1.6	1.6
45	90	57.5	34.5	14.5	23	21	71	34.5	25	60	30		54	40	3	1.7	
55	110	67.5	34.5	14.5	25.5	23.5	86	42	35	62	31		56	40	4.5	2	

Size	L1		L2		L7		L8		L10		n	
ELGR-...	-L	-L	-L	-L	-L	-L	-L	-L	-L	-L	-L	-L
35	178	248	89	124	76	146	70	140	20	40	1	2
45	219	309	108	153	96	186	90	180	25	50	1	2
55	243	353	120	175	116	226	110	220	35	70	1	2

Toothed belt axes ELGR

Technical data

Ordering data

Features:

- Stroke reserve: 0 mm
- Standard slide

Size	Stroke [mm]	Part No.	Type
35	100	8083770	ELGR-TB-35-100-OH
	200	8083771	ELGR-TB-35-200-OH
	300	8083772	ELGR-TB-35-300-OH
	400	8083773	ELGR-TB-35-400-OH
	500	8083774	ELGR-TB-35-500-OH
	600	8083775	ELGR-TB-35-600-OH
45	100	8083776	ELGR-TB-45-100-OH
	200	8083777	ELGR-TB-45-200-OH
	300	8083778	ELGR-TB-45-300-OH
	400	8083779	ELGR-TB-45-400-OH
	500	8083780	ELGR-TB-45-500-OH
	600	8083781	ELGR-TB-45-600-OH
	800	8083782	ELGR-TB-45-800-OH
	1000	8083783	ELGR-TB-45-1000-OH
55	100	8083784	ELGR-TB-55-100-OH
	200	8083785	ELGR-TB-55-200-OH
	300	8083786	ELGR-TB-55-300-OH
	400	8083787	ELGR-TB-55-400-OH
	500	8083788	ELGR-TB-55-500-OH
	600	8083789	ELGR-TB-55-600-OH
	800	8083790	ELGR-TB-55-800-OH
	1000	8083791	ELGR-TB-55-1000-OH
	1200	8083792	ELGR-TB-55-1200-OH
	1500	8083793	ELGR-TB-55-1500-OH

Toothed belt axes ELGR

Ordering data – Modular products



Order code
Mandatory data Additional slide

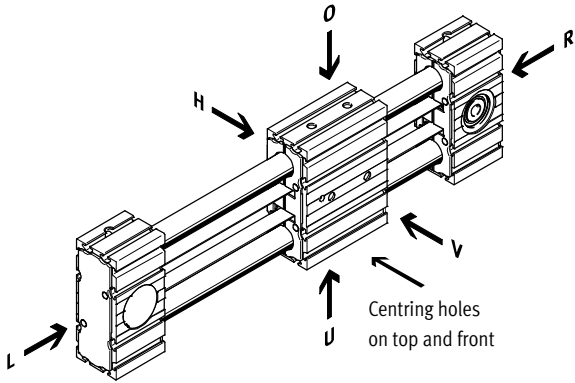

O top L left
U underneath V front
R right H rear

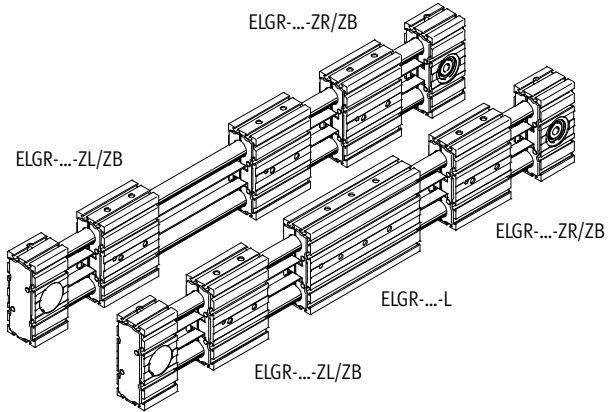

Minimum order stroke in combination with additional slide ELGR-...-ZR/ZL/ZB

Size	35		45		55	
ELGR-...	-ZR/ZL	-ZB	-ZR/ZL	-ZB	-ZR/ZL	-ZB
Min. nominal stroke [mm]	126	202	146	242	166	282

Accessories

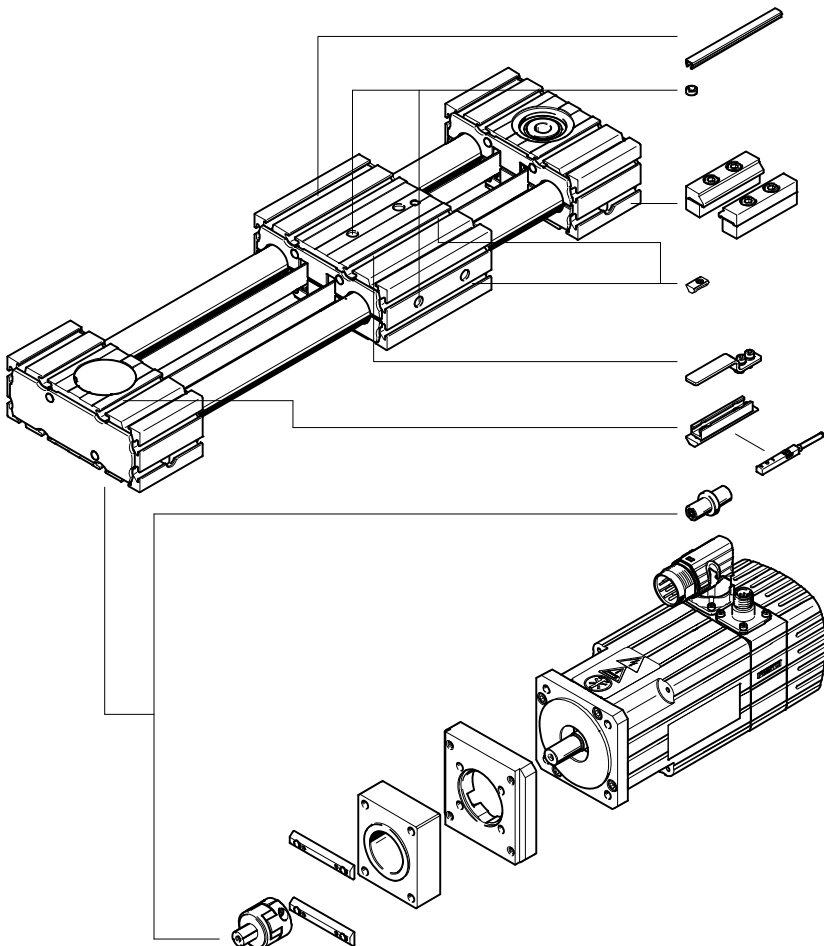

NC

→ page 43

MA

NM

SA, SB

SA, SB

EA

Servo motor
Stepper motor
→ page 38

Axial kit
→ page 38

Toothed belt axes ELGR

Ordering data – Modular products

Ordering table						
Size	35	45	55	Condi- tions	Code	Entry code
[M] Module no.	560505	560506	560507			
Design	Linear axis				ELGR	ELGR
Drive system	Toothed belt				-TB	-TB
[O] Guide	Recirculating ball bearing guide					
	Plain-bearing guide				-GF	
[M] Sizes	35	45	55		-...	
Stroke length [mm]	1 ... 800	1 ... 1000	1 ... 1500	[1]	-...	
Stroke reserve [mm]	0 ... 999 (0 = no stroke reserve)			[1]	-...H	
[O] Slide design	Standard slide					
	Long slide				-L	
Additional slide	No additional slide					
	1 slide on right			[2]	-ZR	
	1 slide on left			[2]	-ZL	
	1 slide on right, 1 slide on left			[2]	-ZB	
Accessories	Accessories enclosed separately				+	+
Proximity sensor (SIES), inductive, slot type 8, PNP, N/O contact, cable 7.5 m, incl. switch lug and sensor bracket	1 ... 6				...SA	
Proximity sensor (SIES), inductive, slot type 8, PNP, N/C contact, cable 7.5 m, incl. switch lug and sensor bracket	1 ... 6				...SB	
Mounting slot cover	-	1 ... 50 (1=2pc. 500 mm long)			...NC	
Slot nut for mounting slot	1 ... 99				...NM	
Drive shaft	1 ... 4				...EA	
Profile mounting	1 ... 2				...MA	
Operating instructions	With operating instructions					
	Without operating instructions				+DN	

[1] ... The sum of the stroke length and 2x the stroke reserve must not exceed the maximum stroke length or be less than the minimum stroke length of 50 mm

[2] **ZR, ZL, ZB** Working stroke reduction → page 17

[M] Mandatory data

[O] Options

Transfer order code

[] [ELGR] - [TB] - [] - [] - [] - [] - [] - [] + [] [] [] [] [] [] []

Toothed belt axes ELGR, for Optimised Motion Series (OMS)

Type codes

ELGR - TB - - 45 - 500 - 0H - - ST - E - B - AT - FR

Type

ELGR	Linear axis
------	-------------

Drive function

TB	Toothed belt
----	--------------

Guide

-	Recirculating ball bearing guide
---	----------------------------------

Size

Stroke [mm]

Stroke reserve

Slide

-	Standard slide
---	----------------

Motor type

ST	Stepper motor
----	---------------

Measuring unit

E	Encoder
---	---------

Brake

-	Without
B	With brake

Cable outlet direction

AT	Top (standard)
AD	Underneath
AL	Left
AR	Right

Motor position

FR	Front right (standard)
FL	Front left
RL	Rear left
RR	Rear right

Toothed belt axes ELGR, for Optimised Motion Series (OMS)

Type codes

→	+			2MA	+	2.5E	+	C5		DIO		N	+	DN	
Cover															
...NC	For mounting slot														
Slot nut															
...NM	For mounting slot														
Profile mounting															
...MA	Profile mounting														
Connecting cable to motor controller															
1.5E	1.5 m, straight plug connector														
2.5E	2.5 m, straight plug connector														
5E	5 m, straight plug connector														
7E	7 m, straight plug connector														
10E	10 m, straight plug connector														
Controller type															
C5	CMMO, 5 A														
Bus protocol/activation															
DIO	Digital I/O interface														
LK	IO-Link														
Switching input/output															
N	NPN														
P	PNP														
Operating instructions															
-	With operating instructions														
DN	Without operating instructions														

Toothed belt axes ELGR, for Optimised Motion Series (OMS)

Peripherals overview

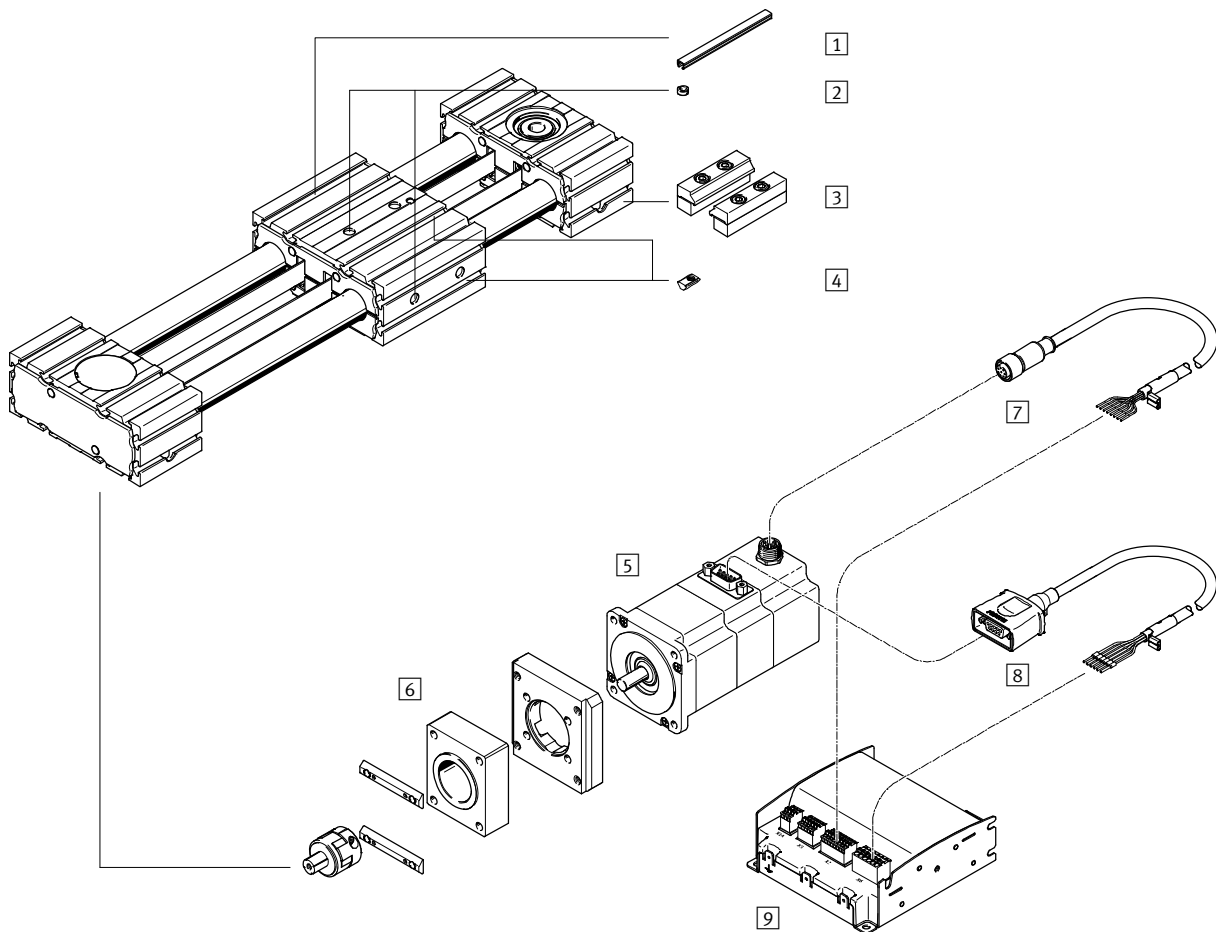

Toothed belt axes ELGR, for Optimised Motion Series (OMS)

Peripherals overview



Accessories			
	Type/order code	Description	→ Page/Internet
1	Slot cover NC	<ul style="list-style-type: none"> For protecting against ingress of dirt 	43
2	Centring sleeve ZBH	<ul style="list-style-type: none"> For centring loads and attachments on the slide 2 centring sleeves included in the scope of delivery of the axis 	43
3	Profile mounting MA	For mounting the axis on the bearing cap	42
4	Slot nut NM	For mounting attachments	43
5	Motor EMMS-ST	Motors specially matched to the axis, with or without brake	38
6	Axial kit EAMM	For axial motor mounting (comprises: coupling, coupling housing and motor flange)	38
7	Encoder cable NEBM	For connecting the encoder and controller	44
8	Motor cable NEBM	For connecting the motor and controller	44
9	Motor controller CMMO	For parameterising and positioning the toothed belt axis	44

Toothed belt axes ELGR, for Optimised Motion Series (OMS)

Technical data

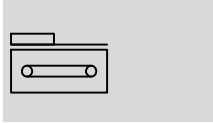
Function



-  - Size
35 ... 55
-  - Stroke length
50 ... 1 500 mm
-  - www.festo.com

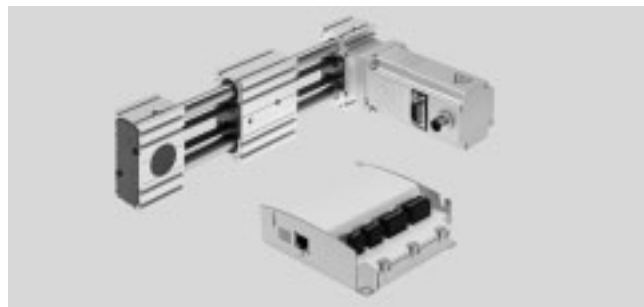

General technical data				
Size		35	45	55
Design		Electromechanical linear axis with toothed belt		
Guide		Recirculating ball bearing guide		
Mounting position		Any		
Standard stroke	[mm]	50, 100, 150, 200, 250, 300, 350, 400, 450, 500, 550, 600, 650, 700, 750, 800	50, 100, 150, 200, 250, 300, 350, 400, 450, 500, 550, 600, 650, 700, 750, 800, 900, 1000	50, 100, 150, 200, 250, 300, 350, 400, 450, 500, 550, 600, 650, 700, 750, 800, 900, 1000, 1100, 1200, 1300, 1400, 1500
Max. working load	[kg]	2.8	5.0	6.8
Max. feed force F_x	[N]	50	100	350
Max. driving torque	[Nm]	0.46	1.24	5
Max. speed	[m/s]	1.1	1.1	0.35
Max. acceleration ¹⁾	[m/s ²]	15		
Repetition accuracy	[mm]	±0.1		

1) In combination with Optimised Motion Series (OMS).
The max. acceleration is dependent on the payload, the driving torque and the max. feed force → page 29

Operating and environmental conditions		
Ambient temperature	[°C]	-10 ... +50
Degree of protection		IP20
Duty cycle	[%]	100

Toothed belt axes ELGR, for Optimised Motion Series (OMS)

Technical data

Weight of axis/axial kit/motor [kg]			
Size	35	45	55
Basic weight with 0 mm stroke ¹⁾			
Axis/axial kit/motor	3.9	8.0	13.2
Additional weight per 1000 mm stroke	2.5	5.0	7.8
Moving mass	0.5	1.1	1.9
Slide			
Standard slide	0.5	1.0	1.8

1) Incl. slide

Materials

Sectional view

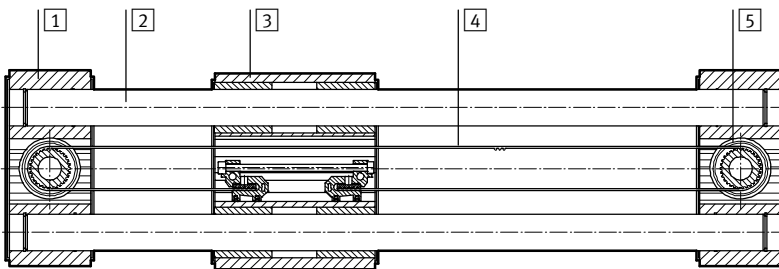

Axis	
1	Bearing cap, profile Anodised wrought aluminium alloy
2	Guide rods Steel
3	Slide, profile Anodised wrought aluminium alloy
4	Toothed belt Polychloroprene with glass cord and nylon coating
5	Belt pulley High-alloy stainless steel
Note on materials RoHS-compliant Contains paint-wetting impairment substances	

Toothed belt axes ELGR, for Optimised Motion Series (OMS)

Technical data

Characteristic load values

The indicated forces and torques refer to the centre of the guide. The point of application of force is the point where the centre of the guide and the longitudinal centre of the slide intersect. These values must not be exceeded during dynamic operation. Special attention must be paid to the cushioning phase.

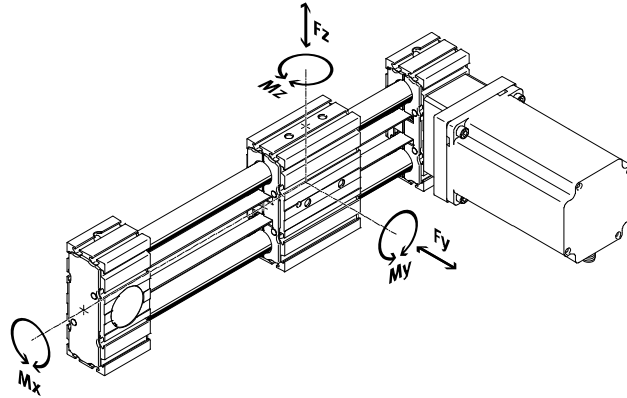

If the axis is subjected to two or more of the indicated forces and torques simultaneously, the following equation must be satisfied in addition to the indicated maximum loads:

Calculating the load comparison factor:

$$f_v = \frac{|F_{y,dyn}|}{F_{y,max}} + \frac{|F_{z,dyn}|}{F_{z,max}} + \frac{|M_{x,dyn}|}{M_{x,max}} + \frac{|M_{y,dyn}|}{M_{y,max}} + \frac{|M_{z,dyn}|}{M_{z,max}} \leq 1$$

Permissible forces and torques for a service life of 5000 km				
Guide		Recirculating ball bearing guide		
Size		35	45	55
$F_{y,max}, F_{z,max}^{1)}$	[N]	50	100	300
Standard slide				
$M_{x,max}$	[Nm]	2.5	5	15
$M_{y,max}$	[Nm]	8	16	48
$M_{z,max}$	[Nm]	8	16	48

1) In combination with Optimised Motion Series (OMS) max. working load limited only by drive system

Service life

The service life of the guide depends on the load. To provide a rough indication of the service life of the guide,

the graph below plots the load comparison factor f_v against the service life.

These values are only theoretical. You must consult your local contact person at Festo for load comparison factors f_v greater than 1.5.

Load comparison factor f_v as a function of service life

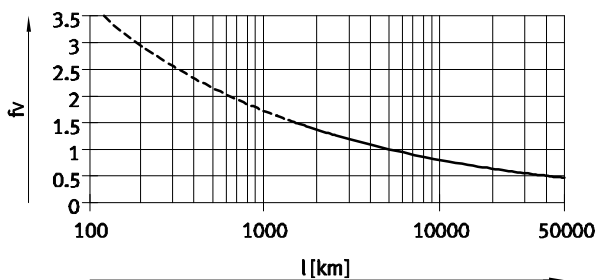

Example:

A user wants to move an X kg load. Using the above formula gives a value of 1.5 for the load comparison factor f_v . According to the graph, the guide would have a service life of

approx. 1500 km. Reducing the acceleration reduces the M_z and M_y values. A load comparison factor of 1 now gives a service life of 5000 km.

Toothed belt axes ELGR, for Optimised Motion Series (OMS)

Technical data

Feed force F_x as a function of input torque M

ELGR-35

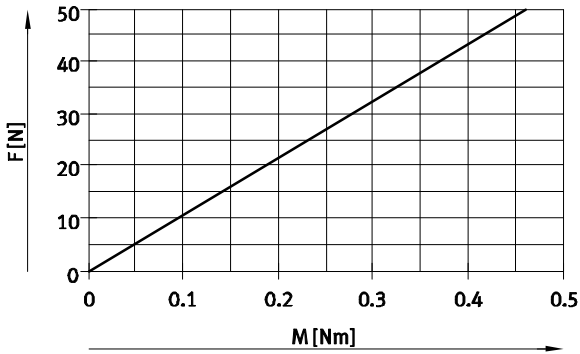

ELGR-45

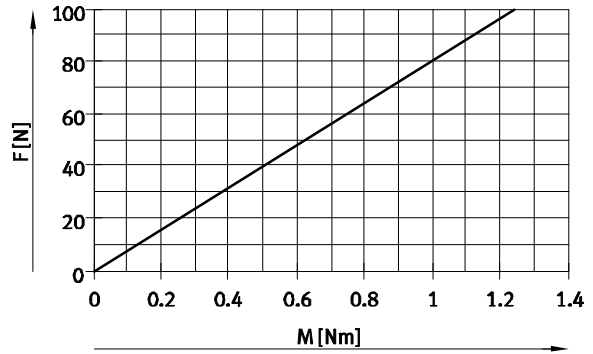

ELGR-55

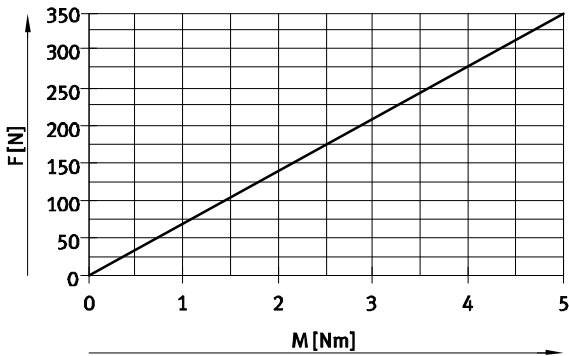

Max. payload m as a function of acceleration a and speed v^1

ELGR-35

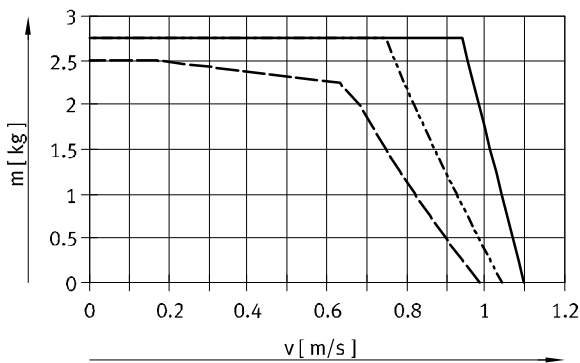

ELGR-45

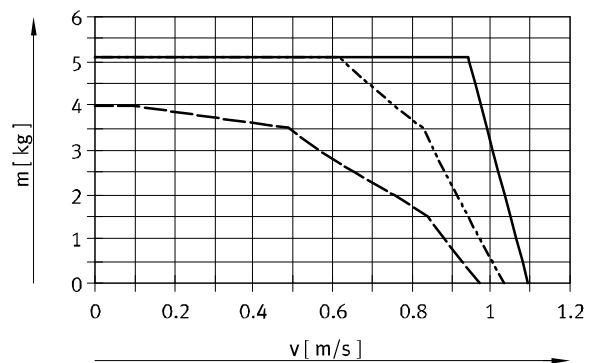

ELGR-55

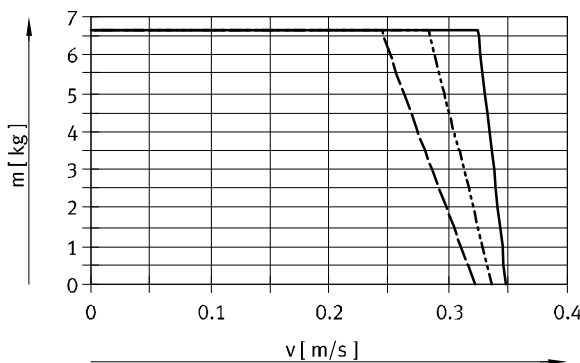

- 5 m/s²
- - - 10 m/s²
- · - 15 m/s²

1) In combination with Optimised Motion Series (OMS)

Toothed belt axes ELGR, for Optimised Motion Series (OMS)

Technical data



Max. payload m as a function of stroke l and positioning time $t^1)$

ELGR-35

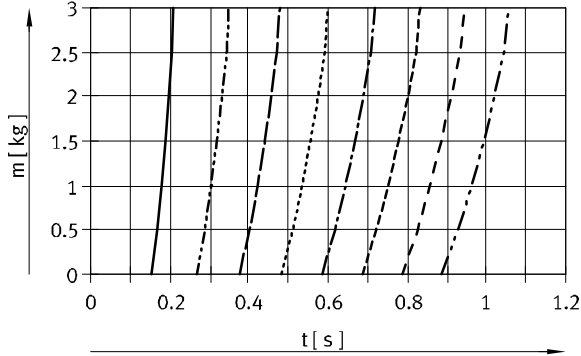

ELGR-45

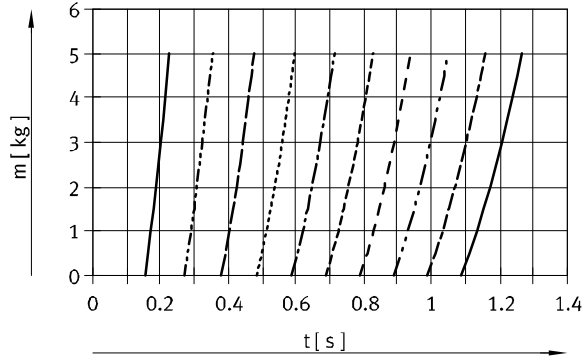

ELGR-55

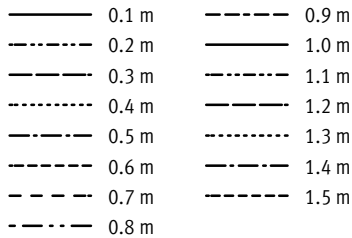
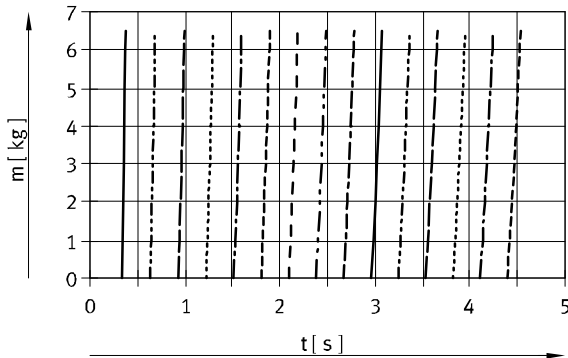

Max. load with flat mounting position¹⁾

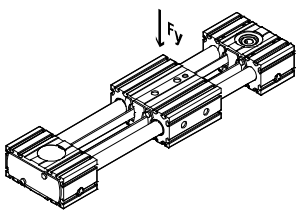

The characteristic curves in the graph correspond to the max. recommended deflection of 0.5 mm.

In this case, the axis can no longer support the maximum load past a certain stroke length.

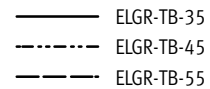
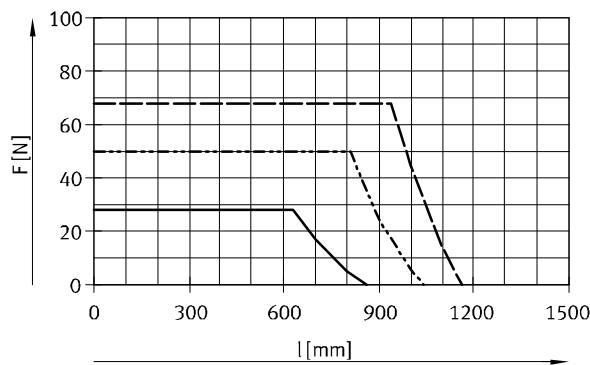

1) In combination with Optimised Motion Series (OMS) max. working load limited only by drive system

Second moment of area

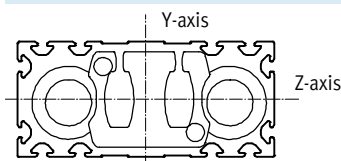

Size	35	45	55
I_y [mm ⁴]	4.19×10^3	17.95×10^3	41.18×10^3
I_z [mm ⁴]	3.77×10^3	15.71×10^3	38.35×10^3

Recommended deflection limits

Adherence to a maximum deflection of 0.5 mm is recommended so as not to impair the functional performance of

the axes. Greater deformation can result in increased friction, greater wear and reduced service life.

Toothed belt axes ELGR, for Optimised Motion Series (OMS)

Technical data

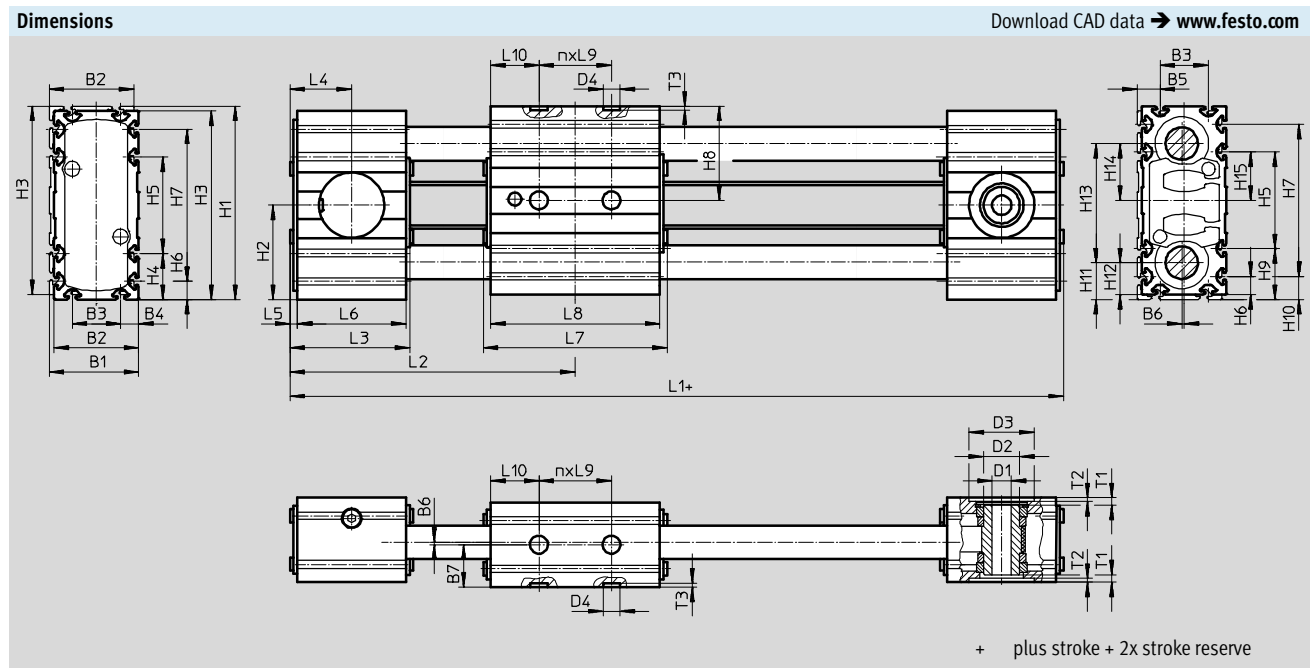

Size	B1	B2	B3	B4	B5	B6	B7	D1 ∅ H7	D2 ∅	D3 ∅ H7
35	37	35	20	7.5	9.5	1	17.5	8	15	27
45	47	45	20	12.5	14.5		22.5	10	20	38
55	57	55	30	12.5	14.5		27.5	16	25	48

Size	D4 ∅ H7	H1	H2	H3	H4	H5	H6	H7	H8	H9
35	7	80	39	78	19	40	7.5	63	39	21
45		117	57.5	115	32.5	50	12.5	90	57.5	34.5
55		137	67.5	135	32.5	70	12.5	110	67.5	34.5

Size	H10	H11	H12	H13	H14	H15	L1	L2	L3	L4
35	9.5	15.5	13.5	49	23.5	20	178	89	51	25.5
45	14.5	23	21	71	34.5	25	219	108	60	30
55	14.5	25.5	23.5	86	42	35	243	120	62	31

Size	L5	L6	L7	L8	L9	L10	T1	T2	T3	n
									+0.1	
35	3	45	76	70	30	20	3.1	1.6	1.6	1
45		54	96	90	40	25	3	1.7		1
55		56	116	110	40	35	4.5	2		1

Toothed belt axes ELGR, for Optimised Motion Series (OMS)

Technical data

Dimensions Download CAD data → www.festo.com

Profile

ELGR-35

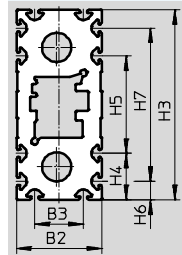

ELGR-45

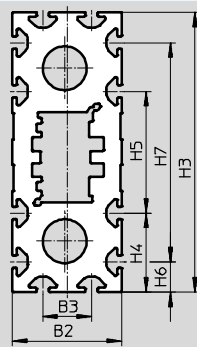

ELGR-55

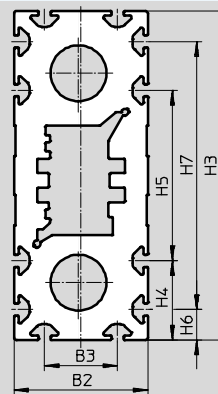

Size	B2	B3	H3	H4
35	35	20	78	19
45	45	20	115	32.5
55	55	30	135	32.5

Size	H5	H6	H7
35	40	7.5	63
45	50	12.5	90
55	70	12.5	110

Toothed belt axes ELGR, for Optimised Motion Series (OMS)

Technical data

Dimensions

Download CAD data → www.festo.com

Motor attachment variants

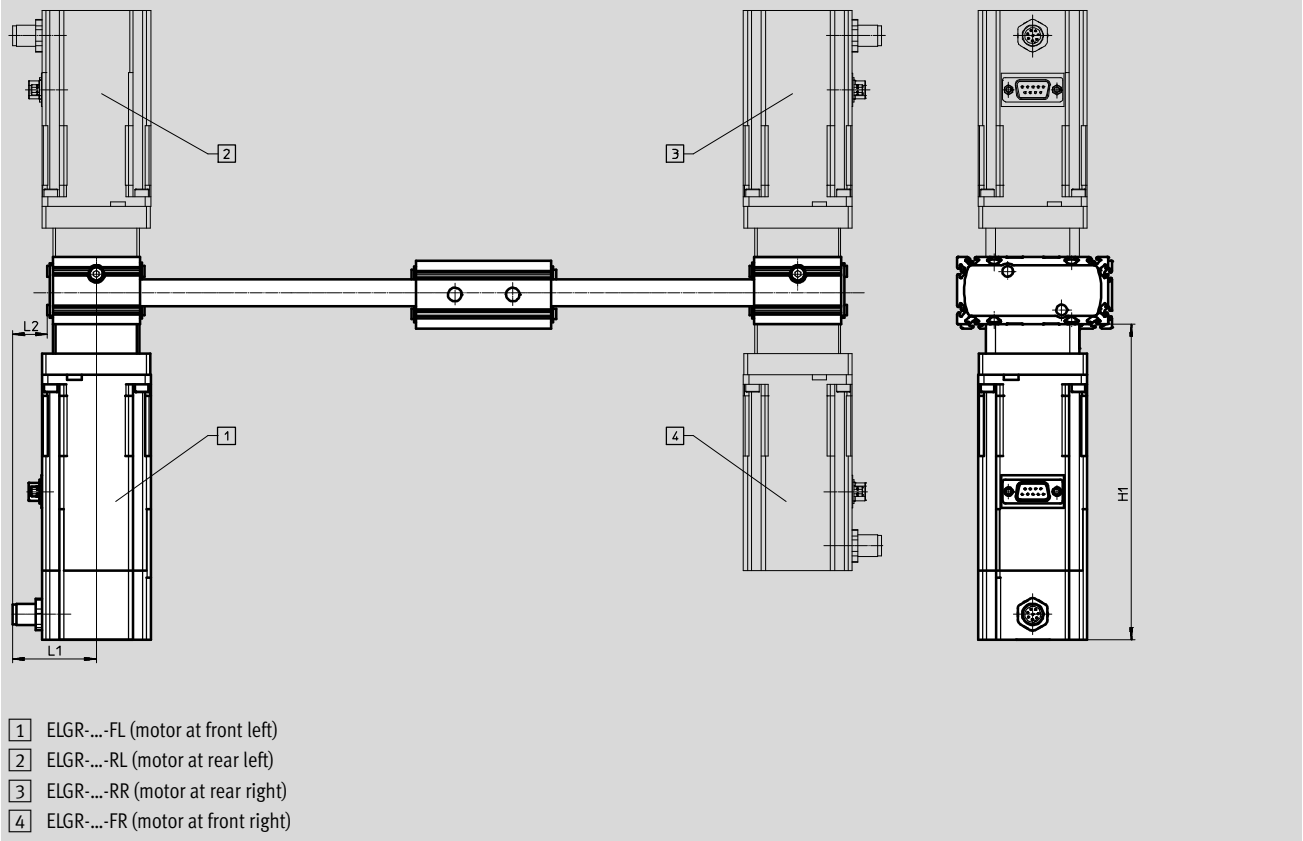

Size	H1		L1		L2	
	ELGR-...	-B	ELGR-...	-B	ELGR-...	-B
35	127.5	163	43.2	44	17.7	18
45	152.4	192.5	58	58	28	28
55	190	230	58	58	27	27

Toothed belt axes ELGR, for Optimised Motion Series (OMS)

Ordering data – Modular products

Order code

Mandatory data

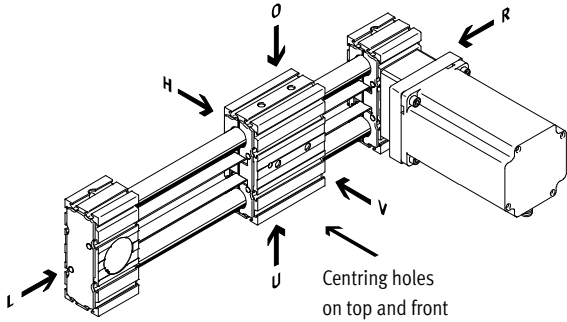

- | | | | |
|---|------------|---|-------|
| O | top | L | left |
| U | underneath | V | front |
| R | right | H | rear |

Motor attachment variants

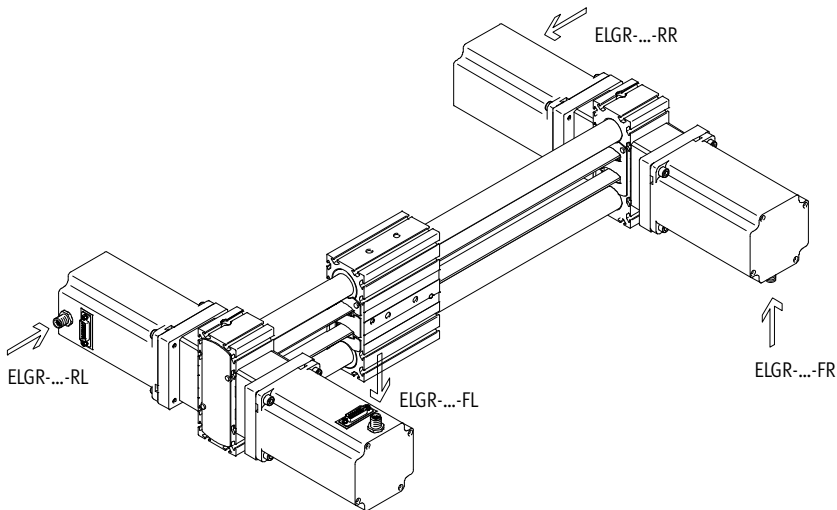

ELGR-...-AR – right

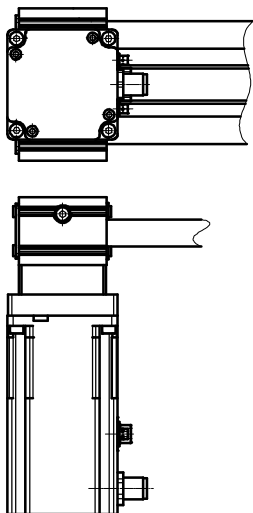

ELGR-...-AT – top

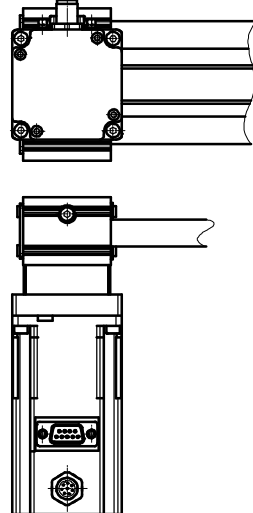

ELGR-...-AL – left

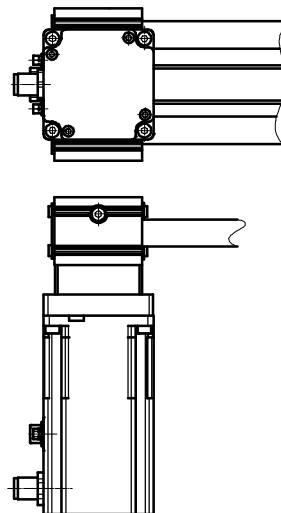

ELGR-...-AD – underneath

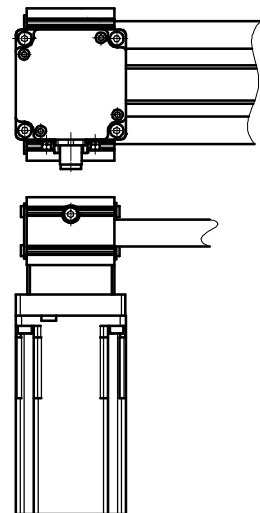

Toothed belt axes ELGR, for Optimised Motion Series (OMS)

Ordering data – Modular product system

Accessories

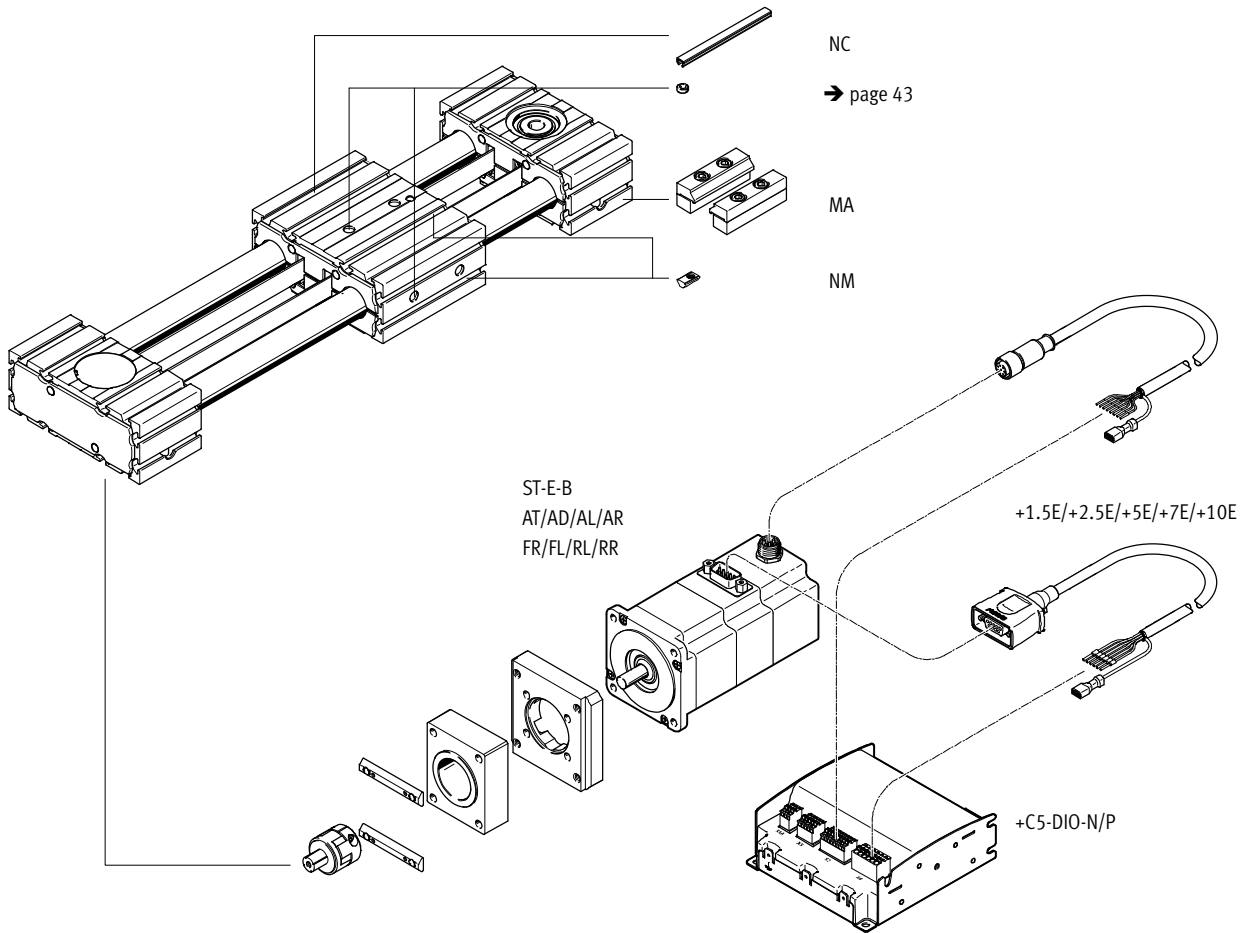

 Note
 The associated axial kit (→ page 38) is automatically included in the scope of delivery. Motor and axial kit are installed on delivery.

Toothed belt axes ELGR, for Optimised Motion Series (OMS)

Ordering data – Modular product system

Ordering table						
Size	35	45	55	Condi- tions	Code	Entry code
M Module no.	560505	560506	560507			
Design	Linear axis				ELGR	ELGR
Drive system	Toothed belt				-TB	-TB
Sizes	35	45	55		-...	
Standard stroke [mm]	50, 100, 150, 200, 250, 300, 350, 400, 450, 500, 550, 600, 650, 700, 750, 800	50, 100, 150, 200, 250, 300, 350, 400, 450, 500, 550, 600, 650, 700, 750, 800, 900, 1000	50, 100, 150, 200, 250, 300, 350, 400, 450, 500, 550, 600, 650, 700, 750, 800, 900, 1000, 1100, 1200, 1300, 1400, 1500			
Stroke reserve [mm]	0 mm				-OH	-OH
Slide design	Standard slide					
Motor type	Stepper motor				-ST	-ST
Measuring unit	Encoder				-E	-E
Brake	Without					
	With brake				B	
Cable outlet direction	Top (standard)				-AT	
	Underneath				-AD	
	Left				-AL	
	Right				-AR	
Motor position	Front right (standard)				-FR	
	Front left				-FL	
	Rear left				-RL	
	Rear right				-RR	

- M** Mandatory data
- O** Options

Transfer order code

Toothed belt axes ELGR, for Optimised Motion Series (OMS)

Ordering data – Modular product system

Ordering table						
Size	35	45	55	Condi- tions	Code	Entry code
	Accessories enclosed separately				+	+
<input type="checkbox"/>	Mounting slot cover	–	1 ... 50 (1=2pc. 500 mm long)		...NC	
	Slot nut for mounting slot	1 ... 99			...NM	
	Profile mounting	1 ... 2			...MA	
<input type="checkbox"/>	Connecting cable to motor controller, suitable for use with energy chains	Without				
		1.5 m, straight plug connector			+1.5E	
		2.5 m, straight plug connector			+2.5E	
		5 m, straight plug connector			+5E	
		7 m, straight plug connector			+7E	
		10 m, straight plug connector			+10E	
	Controller type	CMMO, 5 A			+C5	+C5
	Bus protocol/activation	Digital I/O interface			DIO	
		IO-Link			LK	
	Switching input/output	NPN		<input type="checkbox"/>	N	
		PNP			P	
	Operating instructions	With operating instructions				
		Without operating instructions			+DN	

N Not with LK

- Mandatory data
- Options

Transfer order code

+ - - - + C5 - - +



Toothed belt axes ELGR

Accessories

FESTO

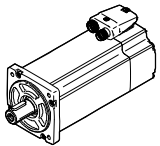
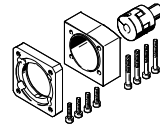

-  - Note

Depending on the combination of motor and drive, it may not be possible to reach the maximum feed force of the drive.

Permissible axis/motor combinations with axial kit		Technical data → Internet: eamm-a	
Motor/gear unit ¹⁾	Axial kit		
			
Type	Part No.	Type	
ELGR-35			
With servo motor			
EMMS-AS-55-...	1133400	EAMM-A-R27-55A	
With servo motor and gear unit			
EMME-AS-40-...	1456622	EAMM-A-R27-40G	
EMGA-40-P-G...-EAS-40			
EMMS-AS-40-...	1456622	EAMM-A-R27-40G	
EMGA-40-P-G...-SAS-40			
With servo motor and angled gear unit			
EMME-AS-40-...	1456622	EAMM-A-R27-40G	
EMGA-40-A-G...-40P			
With stepper motor			
EMMS-ST-57-...²⁾	 1133403	EAMM-A-R27-57A	
With stepper motor and gear unit			
EMMS-ST-42-...	1456622	EAMM-A-R27-40G	
EMGA-40-P-G...-SST-42			
With integrated drive			
EMCA-EC-67-...	1456619	EAMM-A-R27-67A	
With integrated drive and gear unit			
EMCA-EC-67-...	1456622	EAMM-A-R27-40G	
EMGC-40-...			

- 1) The input torque must not exceed the maximum permissible transferable torque of the axial kit
 2) Motors used in combination with Optimised Motion Series (OMS)

Festo core product range

-  Generally ready for shipping ex works in 24 hours
-  Generally ready for shipping ex works in 5 days

Toothed belt axes ELGR

Accessories

FESTO

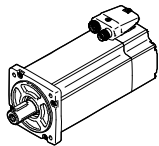
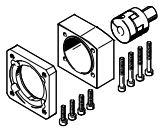
Permissible axis/motor combinations with axial kit		Technical data → Internet: eamm-a
Motor/gear unit ¹⁾	Axial kit	
		
Type	Part No.	Type
ELGR-45		
With servo motor		
EMMT-AS-60-...	★ 2224996	EAMM-A-R38-60P
EMME-AS-60-...	★ 2224996	EAMM-A-R38-60P
EMMS-AS-70-...	1133401	EAMM-A-R38-70A
With servo motor and gear unit		
EMME-AS-40-...	1456623	EAMM-A-R38-40G
EMGA-40-P-G...-EAS-40		
EMMS-AS-40-...	1456623	EAMM-A-R38-40G
EMGA-40-P-G...-SAS-40		
EMMS-AS-55-...	2310075	EAMM-A-R38-60G
EMGA-60-P-G...-SAS-55		
EMMT-AS-60-...	1456630	EAMM-A-R38-60H
EMGA-60-P-G...-EAS-60		
EMME-AS-60-...	1456630	EAMM-A-R38-60H
EMGA-60-P-G...-EAS-60		
EMMS-AS-70-...	2310075	EAMM-A-R38-60G
EMGA-60-P-G...-SAS-70		
With servo motor and angled gear unit		
EMME-AS-40-...	1456623	EAMM-A-R38-40G
EMGA-40-A-G...-40P		
EMMT-AS-60-...	1456630	EAMM-A-R38-60H
EMGA-60-A-G...-60P		
EMME-AS-60-...	1456630	EAMM-A-R38-60H
EMGA-60-A-G...-60P		
With stepper motor		
EMMS-ST-57-...	★ 1578138	EAMM-A-R38-57A
EMMS-ST-87-... ²⁾	★ 1133404	EAMM-A-R38-87A
With stepper motor and gear unit		
EMMS-ST-42-...	1456623	EAMM-A-R38-40G
EMGA-40-P-G...-SST-42		
EMMS-ST-57-...	2310075	EAMM-A-R38-60G
EMGA-60-P-G...-SST-57		
With integrated drive and gear unit		
EMCA-EC-67-...	1456623	EAMM-A-R38-40G
EMGC-40-...		
EMCA-EC-67-...	1456630	EAMM-A-R38-60H
EMGC-60-...		

1) The input torque must not exceed the maximum permissible transferable torque of the axial kit

2) Motors used in combination with Optimised Motion Series (OMS)

Festo core product range

★ Generally ready for shipping ex works in 24 hours

☆ Generally ready for shipping ex works in 5 days

Toothed belt axes ELGR

Accessories

FESTO

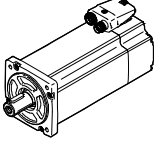
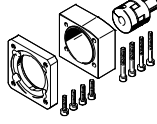
Permissible axis/motor combinations with axial kit		Technical data → Internet: eamm-a	
Motor/gear unit ¹⁾	Axial kit		
			
Type	Part No.	Type	
ELGR-55			
With servo motor			
EMMS-AS-70-...	1578139	EAMM-A-R48-70A	
EMME-AS-80-...	★ 2225090	EAMM-A-R48-80P	
EMMS-AS-100-...	★ 1133402	EAMM-A-R48-100A	
With servo motor and gear unit			
EMMS-AS-55-...	2374780	EAMM-A-R48-60G	
EMGA-60-P-G...-SAS-55			
EMMT-AS-60-...	1456633	EAMM-A-R48-60H	
EMGA-60-P-G...-EAS-60			
EMME-AS-60-...	1456633	EAMM-A-R48-60H	
EMGA-60-P-G...-EAS-60			
EMMS-AS-70-...	2374780	EAMM-A-R48-60G	
EMGA-60-P-G...-SAS-70			
With servo motor and angled gear unit			
EMMT-AS-60-...	1456633	EAMM-A-R48-60H	
EMGA-60-A-G...-60P			
EMME-AS-60-...	1456633	EAMM-A-R48-60H	
EMGA-60-A-G...-60P			
With stepper motor			
EMMS-ST-87-... ²⁾	★ 1133405	EAMM-A-R48-87A	
With stepper motor and gear unit			
EMMS-ST-57-...	2374780	EAMM-A-R48-60G	
EMGA-60-P-G...-SST-57			
With integrated drive and gear unit			
EMCA-EC-67-...	1456633	EAMM-A-R48-60H	
EMGC-60-...			

- 1) The input torque must not exceed the maximum permissible transferable torque of the axial kit
 2) Motors used in combination with Optimised Motion Series (OMS)





Festo core product range

- ★ Generally ready for shipping ex works in 24 hours
- ☆ Generally ready for shipping ex works in 5 days

Toothed belt axes ELGR

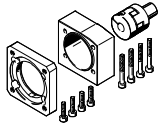
Accessories

FESTO

Permissible axis/motor combinations with axial kit			Technical data → Internet: eamm-a
Axial kit	Axial kit comprises:		
	Motor flange	Coupling	Coupling housing
			
Part No. Type	Part No. Type	Part No. Type	Part No. Type
ELGR-35			
1456622 EAMM-A-R27-40G	1460097 EAMF-A-38A-40G	557998 EAMD-19-15-10-8X10	1133397 EAMK-A-R27-38A
1133400 EAMM-A-R27-55A	558176 EAMF-A-38A-55A	557999 EAMD-19-15-9-8X10	1133397 EAMK-A-R27-38A
★ 1133403 EAMM-A-R27-57A	560692 EAMF-A-38A-57A	561292 EAMD-16-15-6.35-8X10	1133397 EAMK-A-R27-38A
1456619 EAMM-A-R27-67A	1490100 EAMF-A-38A-67A	557999 EAMD-19-15-9-8X10	1133397 EAMK-A-R27-38A
ELGR-45			
1456623 EAMM-A-R38-40G	1460097 EAMF-A-38A-40G	1453860 EAMD-25-22-10-10X12	1133398 EAMK-A-R38-38A
★ 1578138 EAMM-A-R38-57A	560692 EAMF-A-38A-57A	561293 EAMD-25-22-6.35-10X12	1133398 EAMK-A-R38-38A
2310075 EAMM-A-R38-60G	558017 EAMF-A-38A-60G/H	558000 EAMD-25-22-11-10X12	1133398 EAMK-A-R38-38A
1456630 EAMM-A-R38-60H	558017 EAMF-A-38A-60G/H	1453861 EAMD-28-22-14-10X12	1133398 EAMK-A-R38-38A
★ 2224996 EAMM-A-R38-60P	1987412 EAMF-A-38A-60P	1453861 EAMD-28-22-14-10X12	1133398 EAMK-A-R38-38A
1133401 EAMM-A-R38-70A	558018 EAMF-A-38A-70A	558000 EAMD-25-22-11-10X12	1133398 EAMK-A-R38-38A
★ 1133404 EAMM-A-R38-87A	560693 EAMF-A-38A-87A	558000 EAMD-25-22-11-10X12	1133398 EAMK-A-R38-38A
ELGR-55			
2374780 EAMM-A-R48-60G	558019 EAMF-A-48A-60G/H	558001 EAMD-32-32-11-16X20	1133399 EAMK-A-R48-48A
1456633 EAMM-A-R48-60H	558019 EAMF-A-48A-60G/H	1377840 EAMD-32-32-14-16X20	1133399 EAMK-A-R48-48A
1578139 EAMM-A-R48-70A	558025 EAMF-A-48A-70A	558001 EAMD-32-32-11-16X20	1133399 EAMK-A-R48-48A
★ 2225090 EAMM-A-R48-80P	2043427 EAMF-A-48A-80P	558002 EAMD-42-40-19-16X25	1133399 EAMK-A-R48-48A
★ 1133405 EAMM-A-R48-87A	560695 EAMF-A-48A-87A	558001 EAMD-32-32-11-16X20	1133399 EAMK-A-R48-48A
★ 1133402 EAMM-A-R48-100A	558020 EAMF-A-48A-100A	558002 EAMD-42-40-19-16X25	1133399 EAMK-A-R48-48A

Festo core product range

★ Generally ready for shipping ex works in 24 hours

☆ Generally ready for shipping ex works in 5 days

Toothed belt axes ELGR

Accessories



Profile mounting MUE
(Order code MA)

Materials:
Anodised aluminium
RoHS-compliant

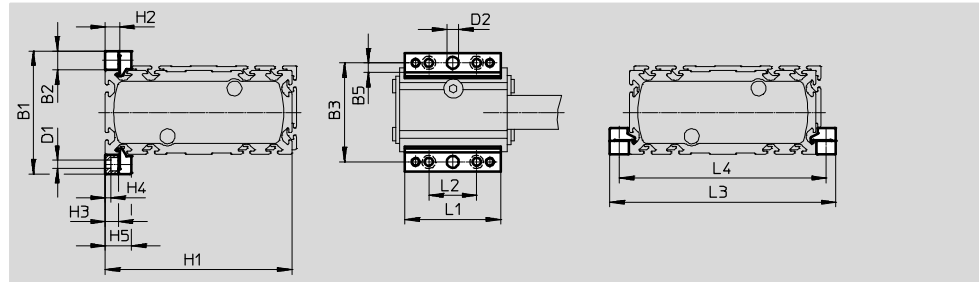

Dimensions and ordering data										
For size	B1	B2	B3	B5	D1 ∅	D2 ∅ H7	H1	H2	H3	H4
35	51	8	43	4	3.4	5	78	6	5.5	2.3
45	69	12	57	4	5.5	5	115	10	9	3.2
55	79	12	67	4	5.5	5	135	10	9	3.2

For size	H5	L1	L2	L3	L4	Weight [g]	Part No.	Type
35	11	40	20	94	86	20	558042	MUE-50
45	17.5	52	40	139	127	32	562238	MUE-45
55	17.5	52	40	159	147	32	562238	MUE-45

**Sensor bracket EAPM-...-SHS,
switch lug EAPM-...-SLS**
(Order code SA/SB)

Materials:
Switch lug: Galvanised steel
Sensor bracket: Wrought aluminium
alloy, anodised
RoHS-compliant

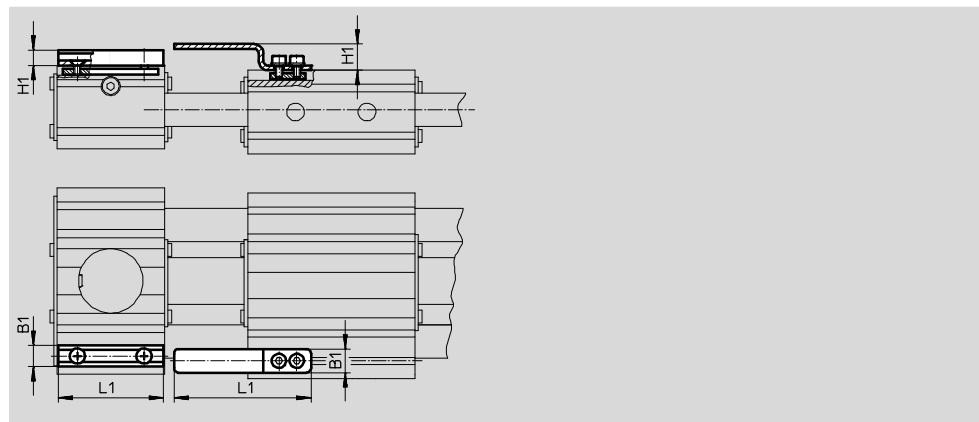

Dimensions and ordering data							
For size	B1	H1	L1	Weight [g]	Part No.	Type	
Sensor bracket							
35, 45, 55	9	6.5	44	20	567537	EAPM-L4-SHS	
Switch lug							
35, 45, 55	10	11	57.5	15	567538	EAPM-L4-SLS	

Toothed belt axes ELGR

Accessories



Drive shaft EAMB

Alternative interface

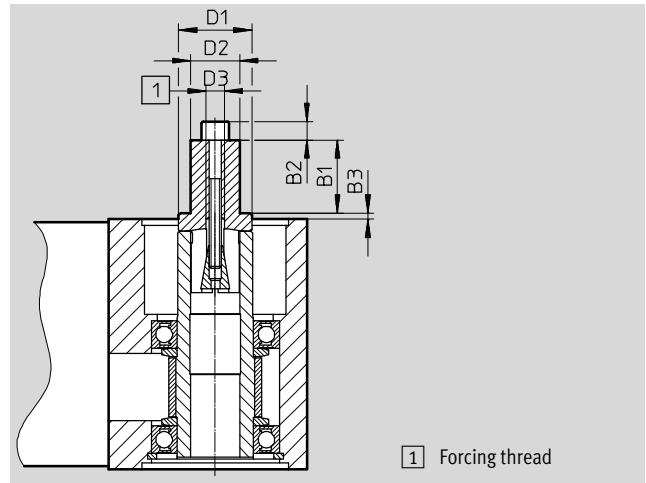
(Order code EA)

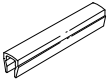

Dimensions and ordering data									
For size	B1	B2	B3	D1 ∅	D2 ∅	D3	Weight [g]	Part No.	Type
35	12	3	3.9	16	8	M4	20	558034	EAMB-16-7-8X15-8X10
45	12	4	6	18	8	M5	29	558035	EAMB-18-9-8X16-10X12
55	21	-	1.5	24	15	M6	70	558036	EAMB-24-6-15X21-16X20

Ordering data						
	For size	Comment	Order code	Part No.	Type	PU ¹⁾
Slot nut NST						
	35	For mounting slot	NM	558045	NST-3-M3	1
	45, 55			150914	NST-5-M5	
			-	8047843	NST-5-M5-10	10
				8047878	NST-5-M5-50	50
Centring sleeve ZBH ²⁾						
	35, 45, 55	For slide	-	186717	ZBH-7	10
Slot cover ABP						
	45, 55	For mounting slot Every 0.5 m	NC	151681	ABP-5	2

1) Packaging unit



2) 2 centring sleeves included in the scope of delivery of the axis

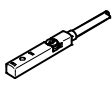

Toothed belt axes ELGR

Accessories

FESTO

Ordering data – Proximity sensor for T-slot, inductive						Technical data → Internet: sies	
	Type of mounting	Electrical connection	Switching output	Cable length [m]	Order code	Part No.	Type
N/O contact							
	Insertable in the slot from above, flush with the cylinder profile	Cable, 3-wire	PNP	7.5	SA	551386	SIES-8M-PS-24V-K-7,5-OE
		Plug connector M8x1, 3-pin		0.3	–	551387	SIES-8M-PS-24V-K-0,3-M8D
		Cable, 3-wire	NPN	7.5	–	551396	SIES-8M-NS-24V-K-7,5-OE
		Plug connector M8x1, 3-pin		0.3	–	551397	SIES-8M-NS-24V-K-0,3-M8D
N/C contact							
	Insertable in the slot from above, flush with the cylinder profile	Cable, 3-wire	PNP	7.5	SB	551391	SIES-8M-PO-24V-K-7,5-OE
		Plug connector M8x1, 3-pin		0.3	–	551392	SIES-8M-PO-24V-K-0,3-M8D
		Cable, 3-wire	NPN	7.5	–	551401	SIES-8M-NO-24V-K-7,5-OE
		Plug connector M8x1, 3-pin		0.3	–	551402	SIES-8M-NO-24V-K-0,3-M8D

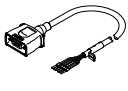
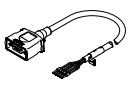
Ordering data – Connecting cables				Technical data → Internet: nebu	
	Electrical connection, left	Electrical connection, right	Cable length [m]	Part No.	Type
	Straight socket, M8x1, 3-pin	Cable, open end, 3-wire	2.5	541333	NEBU-M8G3-K-2.5-LE3
			5.0	541334	NEBU-M8G3-K-5-LE3
	Angled socket, M8x1, 3-pin	Cable, open end, 3-wire	2.5	541338	NEBU-M8W3-K-2.5-LE3
			5.0	541341	NEBU-M8W3-K-5-LE3

Ordering data – Cables ¹⁾					
	For size	Description	Cable length [m]	Part No.	Type
Motor cable					
	35	Straight plug connector – Min. bending radius: 62 mm – Suitability for energy chains – Ambient temp.: –40 ... +80°C	1.5	1450368	NEBM-S1G9-E-1.5-Q5-LE6
			2.5	1450369	NEBM-S1G9-E-2.5-Q5-LE6
			5.0	1450370	NEBM-S1G9-E-5-Q5-LE6
			7.0	1450371	NEBM-S1G9-E-7-Q5-LE6
			10.0	1450372	NEBM-S1G9-E-10-Q5-LE6
	45, 55	Straight plug connector – Min. bending radius: 80 mm – Suitability for energy chains – Ambient temp.: –40 ... +80°C	1.5	1450834	NEBM-S1G15-E-1.5-Q7-LE6
			2.5	1450835	NEBM-S1G15-E-2.5-Q7-LE6
			5.0	1450836	NEBM-S1G15-E-5-Q7-LE6
			7.0	1450837	NEBM-S1G15-E-7-Q7-LE6
			10.0	1450838	NEBM-S1G15-E-10-Q7-LE6
Encoder cable					
	35, 45, 55	Straight plug connector – Min. bending radius: 68 mm – Suitable for use with energy chains – Ambient temp.: –40 ... +80°C	1.5	1451586	NEBM-M12G8-E-1.5-LE8
			2.5	1451587	NEBM-M12G8-E-2.5-LE8
			5.0	1451588	NEBM-M12G8-E-5-LE8
			7.0	1451589	NEBM-M12G8-E-7-LE8
			10.0	1451590	NEBM-M12G8-E-10-LE8

1) Other cable lengths on request.

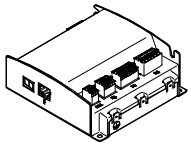
Ordering data			Technical data → Internet: cmmo	
Motor controller	Description	Part No.	Type	
	With I/O interface			
	Switching input/output PNP	1512316	CMMO-ST-C5-1-DIOP	
	Switching input/output NPN	1512317	CMMO-ST-C5-1-DION	
	With IO-Link			
	Switching input/output PNP	1512320	CMMO-ST-C5-1-LKP	