

Spindle axes EGC-HD-BS, with heavy-duty guide

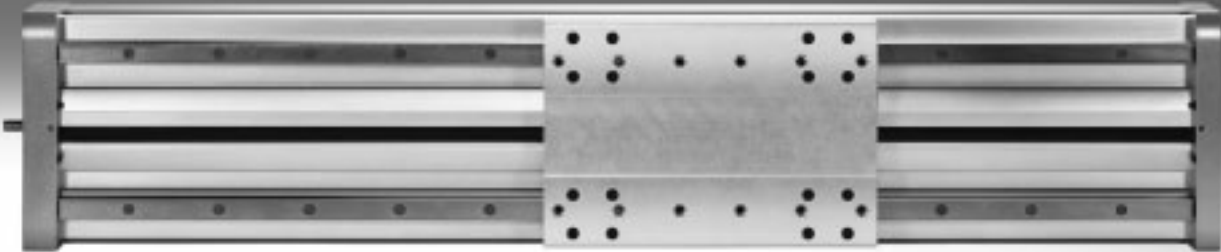

# Electromechanical drives

Selection aid



## Overview of toothed belt and spindle axes

### Toothed belt axes

- Speeds of up to 10 m/s
- Acceleration of up to 50 m/s<sup>2</sup>
- Repetition accuracy of up to ±0.08 mm
- Strokes of up to 8500 mm (longer strokes on request)
- Flexible motor mounting

### Spindle axes

- Speeds of up to 2 m/s
- Acceleration of up to 20 m/s<sup>2</sup>
- Repetition accuracy of up to ±0.003 mm
- Strokes of up to 3000 mm

### Coordinate system

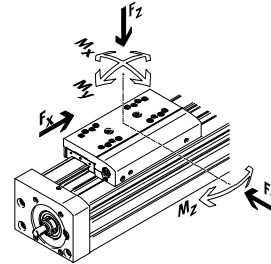

## Toothed belt axes

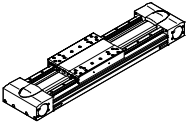
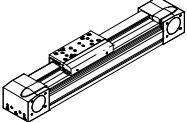
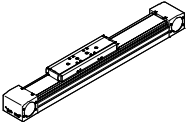
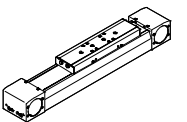
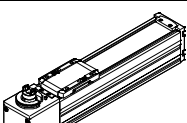
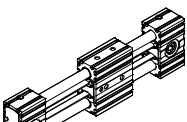
Type	$F_x$ [N]	$v$ [m/s]	$M_x$ [Nm]	$M_y$ [Nm]	$M_z$ [Nm]	Key features
<b>Heavy-duty recirculating ball bearing guide</b>						
<b>EGC-HD-TB</b>						
	450	3	140	275	275	<ul style="list-style-type: none"> <li>• Flat drive unit with rigid, closed profile</li> <li>• Precision DUO guide rail with high load capacity</li> <li>• Ideal as a basic axis for linear gantries and cantilever axes</li> </ul>
	1000	5	300	500	500	
	1800	5	900	1450	1450	
<b>Recirculating ball bearing guide</b>						
<b>EGC-TB-KF</b>						
	50	3	3.5	10	10	<ul style="list-style-type: none"> <li>• Rigid, closed profile</li> <li>• Precision guide rail with high load capacity</li> <li>• Small drive pinions reduce required driving torque</li> <li>• Space-saving position sensing</li> </ul>
	100	5	16	132	132	
	350	5	36	228	228	
	800	5	144	680	680	
	2500	5	529	1820	1820	
<b>ELGA-TB-KF</b>						
	350	5	16	132	132	<ul style="list-style-type: none"> <li>• Internal guide and toothed belt</li> <li>• Precision guide rail with high load capacity</li> <li>• Guide and toothed belt protected by cover strip</li> <li>• High feed forces</li> </ul>
	800	5	36	228	228	
	1300	5	104	680	680	
	2000	5	167	1150	1150	
<b>ELGA-TB-KF-F1</b>						
	260	5	16	132	132	<ul style="list-style-type: none"> <li>• Suitable for use in the food zone</li> <li>• "Clean Look": smooth, easy to clean surfaces</li> <li>• Internal guide and toothed belt</li> <li>• Precision guide rail with high load capacity</li> <li>• Guide and toothed belt protected by cover strip</li> </ul>
	600	5	36	228	228	
	1000	5	104	680	680	
<b>ELGC-TB-KF</b>						
	75	1.2	5.5	4.7	4.7	<ul style="list-style-type: none"> <li>• Internal guide and toothed belt</li> <li>• Precision guide rail with high load capacity</li> <li>• Guide and toothed belt protected by cover strip</li> </ul>
	120	1.5	29.1	31.8	31.8	
	250	1.5	59.8	56.2	56.2	
<b>ELGR-TB</b>						
	50	3	2.5	20	20	<ul style="list-style-type: none"> <li>• Cost-optimised rod guide</li> <li>• Ready-to-install unit</li> <li>• Ball bearings with high load capacity for dynamic operation</li> </ul>
	100	3	5	40	40	
	350	3	15	124	124	

# Electromechanical drives

Selection aid

## Overview of toothed belt and spindle axes

### Toothed belt axes

- Speeds of up to 10 m/s
- Acceleration of up to 50 m/s<sup>2</sup>
- Repetition accuracy of up to ±0.08 mm
- Strokes of up to 8500 mm (longer strokes on request)
- Flexible motor mounting

### Spindle axes

- Speeds of up to 2 m/s
- Acceleration of up to 20 m/s<sup>2</sup>
- Repetition accuracy of up to ±0.003 mm
- Strokes of up to 3000 mm

### Coordinate system

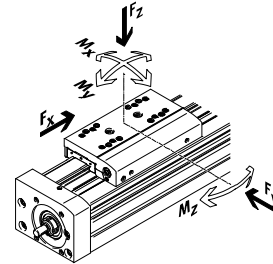

## Toothed belt axes

Type	$F_x$ [N]	$v$ [m/s]	$M_x$ [Nm]	$M_y$ [Nm]	$M_z$ [Nm]	Key features
<b>Roller bearing guide</b>						
<b>ELGA-TB-RF</b>						
	350	10	11	40	40	<ul style="list-style-type: none"> <li>• Heavy-duty roller bearing guide</li> <li>• Guide and toothed belt protected by cover strip</li> <li>• Speeds of up to 10 m/s</li> <li>• Lower weight than axes with guide rails</li> </ul>
	800	10	30	180	180	
	1300	10	100	640	640	
<b>ELGA-TB-RF-F1</b>						
	260	10	8.8	32	32	<ul style="list-style-type: none"> <li>• Suitable for use in the food zone</li> <li>• "Clean Look": smooth, easy to clean surfaces</li> <li>• Heavy-duty roller bearing guide</li> <li>• Guide and toothed belt protected by cover strip</li> <li>• Lower weight than axes with guide rails</li> </ul>
	600	10	24	144	144	
	1000	10	80	512	512	
<b>Plain-bearing guide</b>						
<b>ELGA-TB-G</b>						
	350	5	5	30	10	<ul style="list-style-type: none"> <li>• Guide and toothed belt protected by cover strip</li> <li>• For simple handling tasks</li> <li>• As a drive component for external guides</li> <li>• Insensitive to harsh operating conditions</li> </ul>
	800	5	10	60	20	
	1300	5	120	120	40	
<b>ELGR-TB-GF</b>						
	50	1	1	10	10	<ul style="list-style-type: none"> <li>• Cost-optimised rod guide</li> <li>• Ready-to-install unit</li> <li>• Heavy-duty plain bearings for use in harsh operating conditions</li> </ul>
	100	1	2.5	20	20	
	350	1	1	40	40	

# Electromechanical drives

Selection aid

## Overview of toothed belt and spindle axes

### Toothed belt axes

- Speeds of up to 10 m/s
- Acceleration of up to 50 m/s<sup>2</sup>
- Repetition accuracy of up to ±0.08 mm
- Strokes of up to 8500 mm (longer strokes on request)
- Flexible motor mounting

### Spindle axes

- Speeds of up to 2 m/s
- Acceleration of up to 20 m/s<sup>2</sup>
- Repetition accuracy of up to ±0.003 mm
- Strokes of up to 3000 mm

### Coordinate system

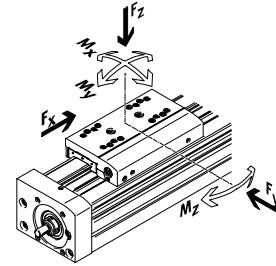

## Spindle axes

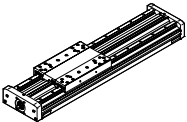
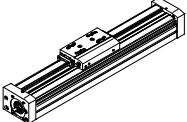
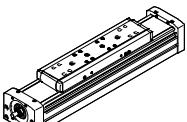
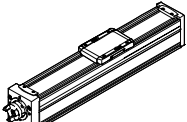
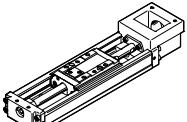
Type	$F_x$ [N]	$v$ [m/s]	$M_x$ [Nm]	$M_y$ [Nm]	$M_z$ [Nm]	Key features
<b>Heavy-duty recirculating ball bearing guide</b>						
EGC-HD-BS						
	400 650 1500	0.5 1.0 1.5	140 300 900	275 500 1450	275 500 1450	<ul style="list-style-type: none"> <li>• Flat drive unit with rigid, closed profile</li> <li>• Precision DUO guide rail with high load capacity</li> <li>• Ideal as a basic axis for linear gantries and cantilever axes</li> </ul>
<b>Recirculating ball bearing guide</b>						
EGC-BS-KF						
	400 650 1500 3000	0.5 1.0 1.5 2.0	16 36 144 529	132 228 680 1820	132 228 680 1820	<ul style="list-style-type: none"> <li>• Rigid, closed profile</li> <li>• Precision guide rail with high load capacity</li> <li>• For the highest requirements in terms of feed force and accuracy</li> <li>• Space-saving position sensing</li> </ul>
ELGA-BS-KF						
	650 1600 3400 6400	0.5 1.0 1.5 2.0	16 36 104 167	132 228 680 1150	132 228 680 1150	<ul style="list-style-type: none"> <li>• Internal guide and ball screw</li> <li>• Precision guide rail with high load capacity</li> <li>• For the highest requirements in terms of feed force and accuracy</li> <li>• Guide and ball screw protected by cover strip</li> <li>• Space-saving position sensing</li> </ul>
ELGC-BS-KF						
	40 100 200 350	0.6 0.6 0.8 1.0	1.3 5.5 29.1 59.8	1.1 4.7 31.8 56.2	1.1 4.7 31.8 56.2	<ul style="list-style-type: none"> <li>• Internal guide and ball screw</li> <li>• Guide and ball screw protected by cover strip</li> <li>• Space-saving position sensing</li> </ul>
EGSK						
	57 133 184 239 392	0.33 1.10 0.83 1.10 1.48	13 28.7 60 79.5 231	3.7 9.2 20.4 26 77.3	3.7 9.2 20.4 26 77.3	<ul style="list-style-type: none"> <li>• Spindle axes with maximum precision, compactness and rigidity</li> <li>• Recirculating ball bearing guide and ball screw without caged ball bearings</li> <li>• Standard designs in stock</li> </ul>

# Spindle axes EGC-HD-BS, with heavy-duty guide

## Key features

### At a glance

- New heavy-duty guide for:
  - Maximum loads and torques
  - High feed forces and speeds
  - Long service life
- Precision, resilient DUO guide rail
- Ideal as a basic axis for linear gantries and cantilever axes
- The spindle axis with integrated ball screw combines high precision and flexible spindle pitches
- In addition to its technical data, the spindle axis also offers an excellent price/performance ratio
- Space-saving position sensing with proximity sensor in the profile slot
- Wide range of options for mounting on drives
- Spindle support enables maximum travel speed with all stroke lengths

### Flat unit with rigid, closed profile

EGC-HD-125

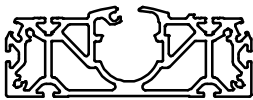

EGC-HD-160

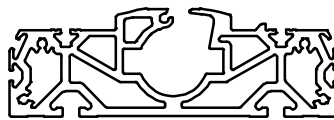

EGC-HD-220

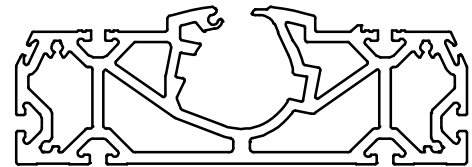

### Characteristic values of the axes

The specifications shown in the table are maximum values.

The precise values for each of the variants can be found in the relevant technical data section.

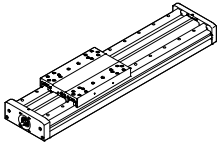
Version	Size	Working stroke [mm]	Speed [m/s]	Repetition accuracy [mm]	Max. Feed force [N]	Guide characteristics				
						Forces and torques				
						F <sub>y</sub> [N]	F <sub>z</sub> [N]	M <sub>x</sub> [Nm]	M <sub>y</sub> [Nm]	M <sub>z</sub> [Nm]
<b>Recirculating ball bearing guide</b>										
	125	50 ... 900	0.5	±0.02	400	3650	3650	140	275	275
	160	50 ... 1900	1	±0.02	650	5600	5600	300	500	500
	220	50 ... 2400	1.5	±0.02	1500	13000	13000	900	1450	1450

-  - Note

PositioningDrives  
sizing software  
[www.festo.com](http://www.festo.com)

# Spindle axes EGC-HD-BS, with heavy-duty guide

Key features

## Slide variants

Standard slide



Standard slide, protected



With additional slide



## Complete system comprising spindle axis, motor, motor controller and motor mounting kit

Spindle axis with recirculating ball bearing guide



## Motor

→ page 26



1



2

- 1 Servo motor EMME-AS, EMMS-AS
- 2 Stepper motor EMMS-ST



Note

A range of specially adapted complete solutions is available for the spindle axis EGC and the motors.

## Motor controller

Technical data → Internet: motorcontroller



1



2

- 1 Servo motor controller CMMP-AS
- 2 Stepper motor controller CMMS-ST

## Mounting kit

Axial kit

→ page 26

Parallel kit

→ page 31



# Spindle axes EGC-HD-BS, with heavy-duty guide

Type codes

	EGC	-	HD	-	160	-	500	-	BS	-	10	-		-	20	-	GK	
<b>Type</b>																		
EGC	Spindle axis																	
<b>Guide</b>																		
HD	Heavy-duty guide																	
<b>Size</b>																		
<b>Stroke [mm]</b>																		
<b>Drive function</b>																		
BS	Spindle																	
<b>Spindle pitch</b>																		
<b>Spindle support</b>																		
-	None																	
S	With spindle support																	
<b>Stroke reserve</b>																		
<b>Slide</b>																		
GK	Standard slide																	
GP	Standard slide, protected																	

		-		ZUB	-	2MX2Z	-	DN
<b>Additional slide</b>								
KL	Standard, left							
<b>Additional slide</b>								
KR	Standard, right							
<b>Accessories enclosed separately</b>								
...M	Profile mounting							
...B	Mounting slot cover							
...S	Sensor slot cover							
...Y	Slot nut for mounting slot							
...X	Proximity sensor (SIES), inductive, slot type 8, PNP, N/O contact, 7.5 m cable							
...Z	Proximity sensor (SIES), inductive, slot type 8, PNP, N/C contact, 7.5 m cable							
...A	Emergency buffer with retainer							
...O	Proximity sensor (SIEN), inductive, M8, PNP, N/O contact, 2.5 m cable							
...P	Proximity sensor (SIEN), inductive, M8, PNP, N/C contact, 2.5 m cable							
...W	Proximity sensor (SIEN), inductive, M8, PNP, N/O contact, plug M8							
...R	Proximity sensor (SIEN), inductive, M8, PNP, N/C contact, plug M8							
...V	Connecting cable							
...CL	Cable clip							
<b>Operating instructions</b>								
DN	None							

# Spindle axes EGC-HD-BS, with heavy-duty guide

Peripherals overview

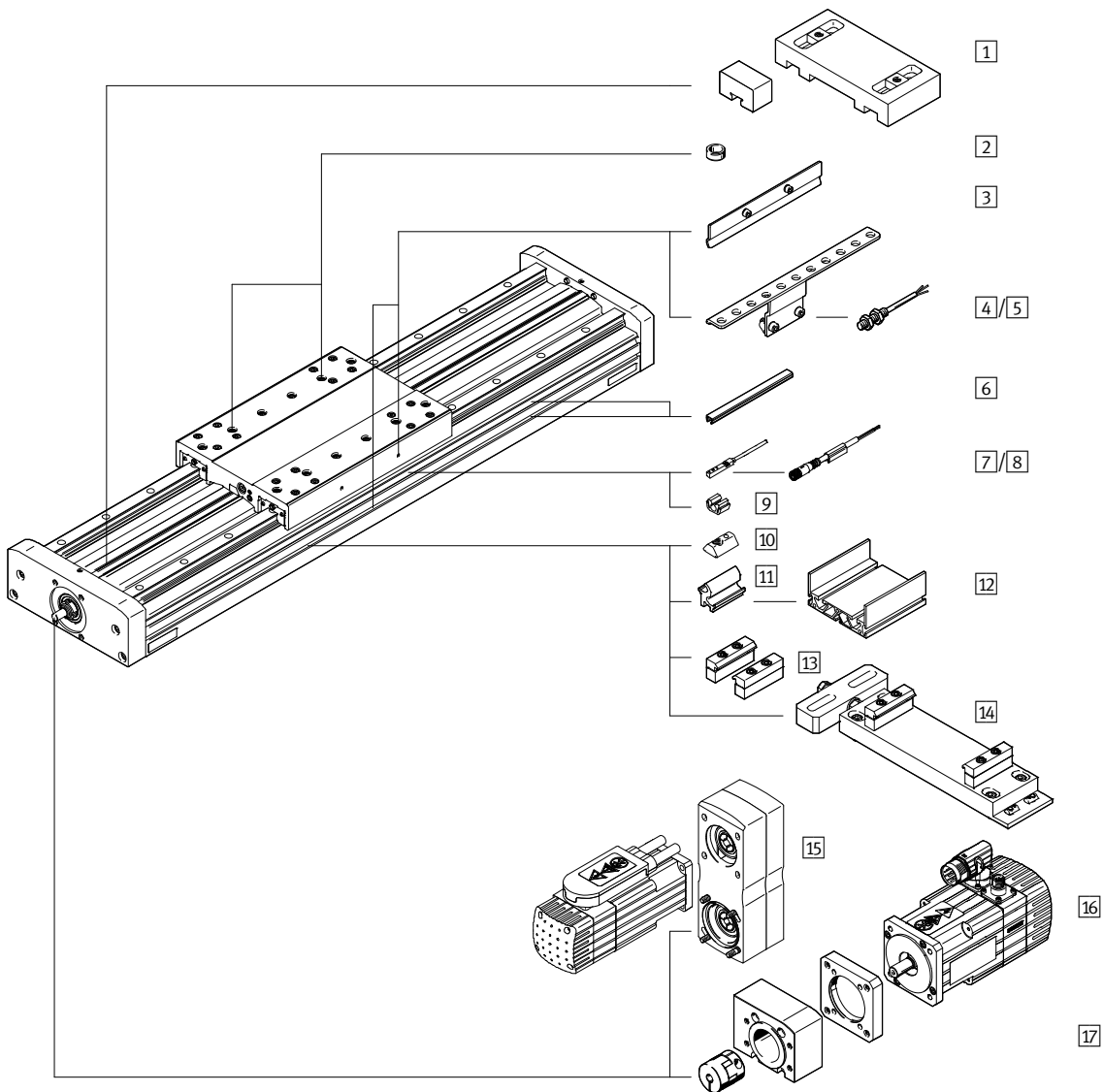



# Spindle axes EGC-HD-BS, with heavy-duty guide

Peripherals overview



Variants and accessories		
Type	Description	→ Page/Internet
1 Emergency buffer with retainer A	For avoiding damage at the end stop in the event of malfunction	34
2 Centring pin/sleeve ZBS, ZBH	<ul style="list-style-type: none"> <li>For centring loads and attachments on the slide</li> <li>– Included in the scope of delivery: For size 125: 2x ZBS-5, 2x ZBH-9 For size 160, 220: 2x ZBH-9</li> </ul>	36
3 Switch lug X, Z, O, P, W, R	For sensing the slide position	34
4 Sensor bracket O, P, W, R	Adapter for mounting the inductive proximity sensors (round design) on the axis	35
5 Proximity sensor, M8 O, P, W, R	<ul style="list-style-type: none"> <li>Inductive proximity sensor, round design</li> <li>The order code O, P, W, R includes 1 switch lug and max. 2 sensor brackets</li> </ul>	37
6 Slot cover B, S	<ul style="list-style-type: none"> <li>For protecting against the ingress of dirt</li> </ul>	36
7 Proximity sensor, T-slot X, Z	<ul style="list-style-type: none"> <li>Inductive proximity sensor, for T-slot</li> <li>The order code X, Z includes 1 switch lug</li> </ul>	36
8 Connecting cable V	For proximity sensor (order code W and R)	38
9 Clip CL	For mounting the proximity sensor cable in the slot	36
10 Slot nut Y	For mounting attachments	36
11 Adapter kit DHAM	For mounting the support profile on the axis	37
12 Support profile HMIA	For mounting and guiding an energy chain	37
13 Profile mounting M	For mounting the axis on the profile	32
14 Adjusting kit EADC-E16	Used to mount the axis on a vertical surface. Following mounting, the axis can be aligned horizontally	33
15 Parallel kit EAMM-U	For parallel motor mounting, pointing upwards or downwards only (consisting of: housing, clamping component, toothed belt pulley, toothed belt)	31
16 Motor EMME, EMMS	Motors specially matched to the axis, with or without gear unit, with or without brake	26
17 Axial kit EAMM-A	For axial motor mounting (consisting of: coupling, coupling housing and motor flange)	26

# Spindle axes EGC-HD-BS, with heavy-duty guide

Technical data

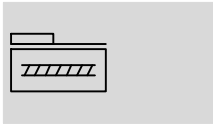
Function



-  - Size  
125 ... 220
-  - Stroke length  
50 ... 2400 mm
-  - [www.festo.com](http://www.festo.com)



General technical data						
Size		125	160			220
Spindle pitch	[mm/ rev.]	10	10	20	10	25
Design	Electromechanical axis with recirculating ball spindle					
Guide	Recirculating ball bearing guide					
Mounting position	Any					
Working stroke	[mm]	50 ... 900	50 ... 1900		50 ... 2400	
Max. feed force $F_x^{1)}$	[N]	400	650		1500	
No-load torque at min. travel speed t						
EGC-...-	[Nm]	0.3	0.5	0.5	1.5	1.5
EGC-...-S	[Nm]	0.3	0.5	0.5	1.5	1.5
	[m/s]	0.05	0.1	0.1	0.2	0.2
No-load torque at max. travel speed t						
EGC-...-	[Nm]	0.45	0.75	0.75	2.25	2.25
EGC-...-S	[Nm]	0.45	0.75	0.75	2.25	2.25
	[m/s]	0.5	0.5	1.0	0.6	1.5
Max. radial force <sup>2)</sup>	[N]	220	250	250	500	500
Max. speed <sup>3)</sup>	[1/min]	3000	3000	3000	3600	3600
Max. acceleration	[m/s <sup>2</sup> ]	15				
Repetition accuracy	[mm]	±0.02				

1) Maximum feed force affects service life (→ page 14)

2) At the drive shaft

3) Rotational speed and speed are stroke-dependent

Operating and environmental conditions		
Ambient temperature	[°C]	-10 ... +60
Protection class	IP40	
Duty cycle	[%]	100

Weight [g]			
Size	125	160	220
Basic weight with 0 mm stroke <sup>1)</sup>	4123	7210	19137
Additional weight per 10 mm stroke	90	138	250
Slide			
EGC-...-GK	1049	2080	5826
EGC-...-GP	-	2346	6325
Additional slide			
EGC-...-GK	978	1963	5505
EGC-...-GP	-	2035	5584

1) Incl. slide

# Spindle axes EGC-HD-BS, with heavy-duty guide

Technical data

Spindle						
Size		125	160		220	
Diameter	[mm]	12	15		25	
Pitch	[mm/rev.]	10	10	20	10	25

Mass moment of inertia						
Size		125	160		220	
Spindle pitch	[mm/rev.]	10	10	20	10	25
$J_0$	[kg mm <sup>2</sup> ]	6.06	13.94	29.74	106.78	184.26
$J_S$ per metre stroke	[kg mm <sup>2</sup> /m]	14.20	34.59	34.59	275.64	275.64
$J_L$ per kg effective load	[kg mm <sup>2</sup> /kg]	2.53	2.53	10.13	2.53	15.83
$J_W$ Additional slide	[kg mm <sup>2</sup> ]	2.25	4.69	18.77	13.20	82.48

The mass moment of inertia  $J_A$  of the entire axis is calculated as follows:  
 $J_A = J_0 + J_W + J_S \times \text{working stroke [m]} + J_L \times m_{\text{effective load [kg]}}$

## Materials

Sectional view

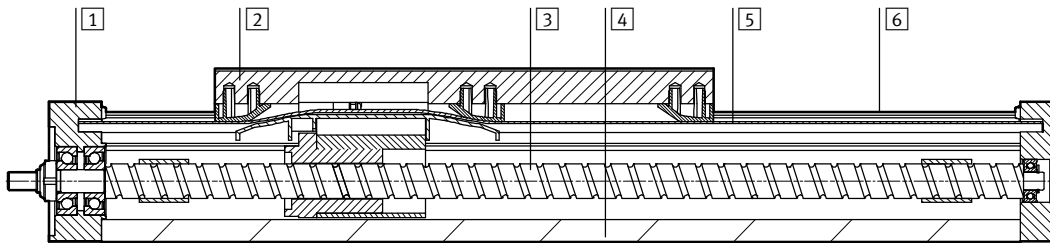

Axis		
1	Drive cover	Anodised wrought aluminium alloy
2	Slide	Anodised wrought aluminium alloy
3	Spindle	Steel
4	Profile	Anodised wrought aluminium alloy
5	Cover strip	Polyurethane
6	Guide rail	Coated and corrosion-resistant steel
Note on materials		Conforms to RoHS
		Contains PWIS (paint-wetting impairment substances)

# Spindle axes EGC-HD-BS, with heavy-duty guide

Technical data



## Characteristic load values

The indicated forces and torques refer to the slide surface. The point of application of force is the point where the centre of the guide and the longitudinal centre of the slide intersect.

These values must not be exceeded during dynamic operation. Special attention must be paid to the cushioning phase.

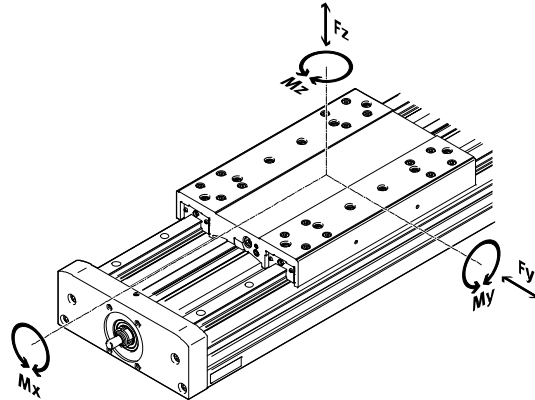

Max. permissible forces and torques for a service life of 5000 km						
Size		125	160	220		
F <sub>y,max.</sub>	[N]	3650	5600	13000		
F <sub>z,max.</sub>	[N]	3650	5600	13000		
M <sub>x,max.</sub>	[Nm]	140	300	900		
M <sub>y,max.</sub>	[Nm]	275	500	1450		
M <sub>z,max.</sub>	[Nm]	275	500	1450		

Basic load ratings						
Size		125	160	220		
Spindle pitch		10	10	20	10	25
Ball screw						
Dynamic c <sub>dyn,BS</sub>	[N]	4000	6800	5700	14100	12700

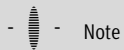

Note

For a service life of 5000 km for the guide system, the load comparison factor must have a value of  $f_v \leq 1$ , based on the maximum permissible forces and torques for a service life of 5000 km.

If the axis is simultaneously subjected to several of the indicated forces and torques, the following equation

must be satisfied in addition to the indicated maximum loads:

Calculating the load comparison factor:

$$f_v = \frac{|F_{y,dyn}|}{F_{y,max}} + \frac{|F_{z,dyn}|}{F_{z,max}} + \frac{|M_{x,dyn}|}{M_{x,max}} + \frac{|M_{y,dyn}|}{M_{y,max}} + \frac{|M_{z,dyn}|}{M_{z,max}} \leq 1$$

# Spindle axes EGC-HD-BS, with heavy-duty guide

Technical data

## Service life of the guide

The service life of the guide depends on the load. To provide a rough indication of the service life of the guide, the graph below plots the load comparison factor  $f_v$  against the service life.

These values are only theoretical. You must consult your local contact person at Festo for load comparison factors  $f_v$  greater than 1.5.

### Load comparison factor $f_v$ as a function of service life

Example:

A user wants to move an X kg load. Using the formula → page 12 gives a value of 1.5 for the load comparison factor  $f_v$ . According to the graph, the guide would have a service life of approx. 1500 km. Reducing the acceleration reduces the  $M_z$  and  $M_y$  values. A load comparison factor  $f_v$  of 1 now gives a service life of 5000 km.

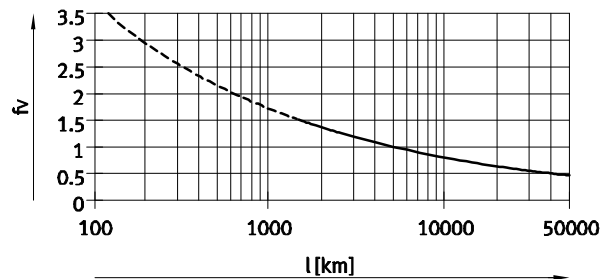

Note

PositioningDrives  
sizing software  
www.festo.com

The guide workload for a service life of 5000 km can be calculated with the help of the sizing software.  
 $f_v > 1.5$  are only theoretical comparison values for the recirculating ball bearing guide.

## Comparison of the characteristic load values for 5000 km with dynamic forces and torques of recirculating ball bearing guides

The characteristic load values of roller bearing guides are standardised to ISO and JIS using dynamic and static forces and torques. These forces and torques are based on an expected service life for the guide system of 100 km to ISO or 50 km to JIS.

As the characteristic load values are dependent on the service life, the max. permissible forces and torques for a service life of 5000 km cannot be compared with the dynamic forces and torques of roller bearing guides to ISO/JIS.

To make it easier to compare the guide capacity of linear axes EGC with roller bearing guides, the table below lists the theoretically permissible forces and torques for a calculated service life of 100 km. This corresponds to the dynamic forces and torques to ISO.

These 100 km values have been calculated mathematically and are only to be used for comparing with dynamic forces and torques to ISO. The drives must not be loaded with these characteristic values as this could damage them.

### Max. permissible forces and torques for a theoretical service life of 100 km (from a guide perspective only)

Size		125	160	220
$F_{y_{max}}$	[N]	13447	20631	47892
$F_{z_{max}}$	[N]	13447	20631	47892
$M_{x_{max}}$	[Nm]	516	1105	3316
$M_{y_{max}}$	[Nm]	1013	1842	5342
$M_{z_{max}}$	[Nm]	1013	1842	5342

# Spindle axes EGC-HD-BS, with heavy-duty guide

Technical data

## Service life of the spindle

- The service life of the spindle axis depends on the service life of the guide (→ page 13) and of the lead screw.  
The operating coefficient plays a considerable role in determining the possible service life and it can be determined with the help of the table (→ page 15)
- The service life ends when the maximum number of switching cycles or maximum running performance has been reached:
  - 5 million switching cycles or service life of 5000 km
- The distance between the foremost and rearmost positions must be at least 2.5 times the spindle pitch per travel cycle.
- The specifications for running performance are based on experimentally determined and theoretically calculated data (at room temperature).  
The running performance that can be achieved in practice can deviate considerably from the specified curves under different parameters

## Calculation of the mean feed force $F_{xm}$ with ball screw

$$F_{xm} = \sqrt[3]{\frac{F_{x1}^3 \times s_1 + \dots + F_{xn}^3 \times s_n}{s_1 + \dots + s_n}}$$

$F_{xm}$  = Mean feed force

$F_{x1/n}$  = Feed force of section

$s_{1/n}$  = Share of movement cycle that is travel

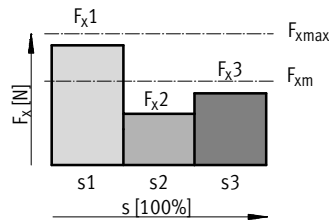

## Mean feed force $F_{xm}$ as a function of running performance L, with an operating coefficient $f_B$ of 1.0 at room temperature

Size 125

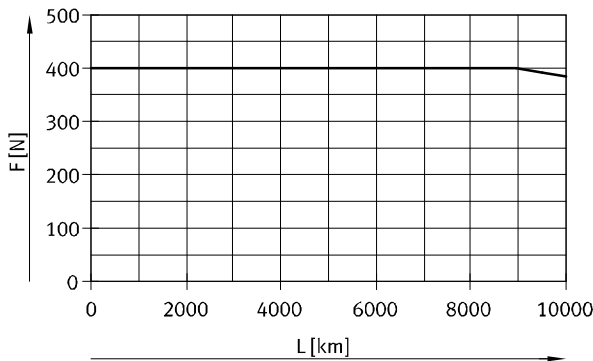

Size 160

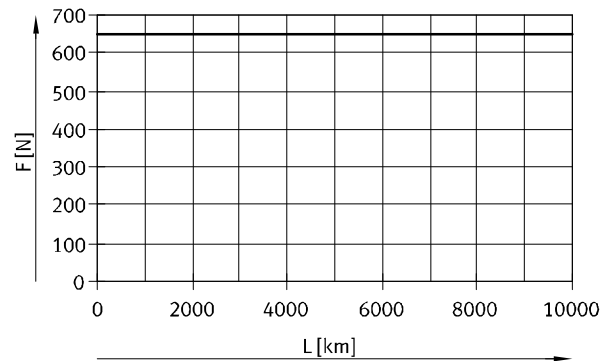

# Spindle axes EGC-HD-BS, with heavy-duty guide

Technical data

Mean feed force  $F_{xm}$  as a function of running performance L, with an operating coefficient  $f_B$  of 1.0 at room temperature  
Size 220

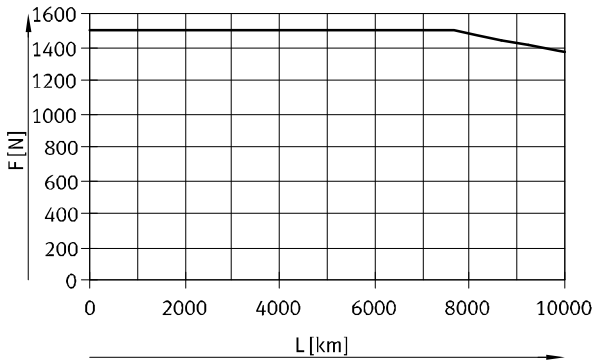

Life cycle taking into account the operating coefficient

$$L_{ist} = \frac{L}{f_B^3}$$

$L_{ist}$  = Actual service life

L = Target service life

(→ graphs)

$f_B$  = Operating coefficient

Load <sup>1)</sup>	Operating coefficient $f_B$	Sample application
None	1.0 ... 1.2	Measuring machine
Lightweight	1.2 ... 1.4	Handling, robot technology
Medium	1.4 ... 1.6	Press-in operations
High	1.6 ... 2.0	Construction, agriculture

1) Stress caused by impacts, temperature, contamination, shocks or vibration

# Spindle axes EGC-HD-BS, with heavy-duty guide

Technical data

## Speed v as a function of working stroke l

Size 125

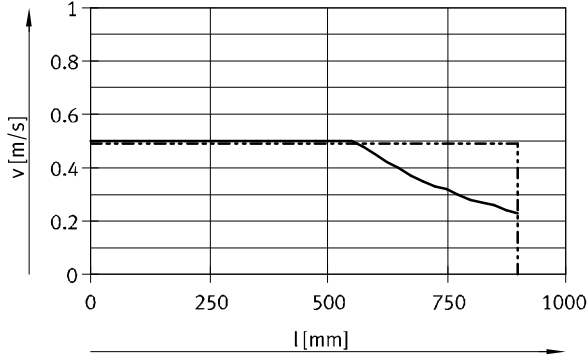

- EGC-HD-125-10P without spindle support
- - - EGC-HD-125-10P with spindle support

Size 160

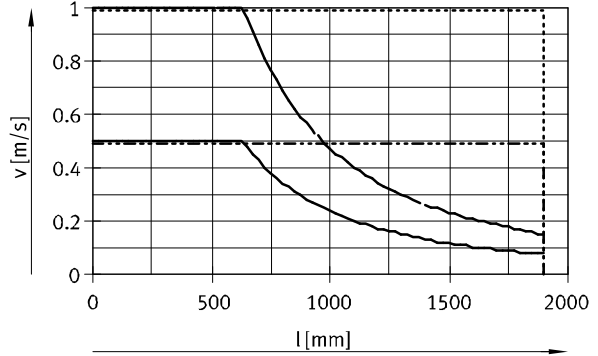

- EGC-HD-160-10P without spindle support
- - - EGC-HD-160-10P with spindle support
- · - EGC-HD-160-20P without spindle support
- · · EGC-HD-160-20P with spindle support

Size 220

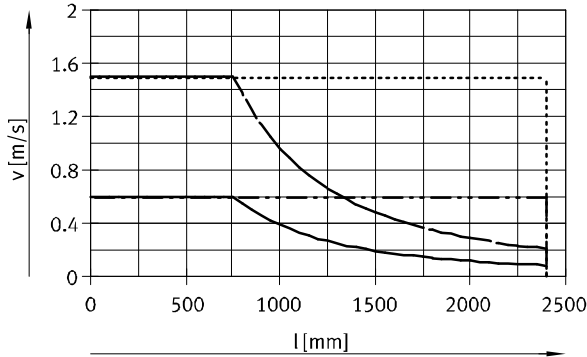

- EGC-HD-220-10P without spindle support
- - - EGC-HD-220-10P with spindle support
- · - EGC-HD-220-25P without spindle support
- · · EGC-HD-220-25P with spindle support

## Speed v as a function of rotational speed n

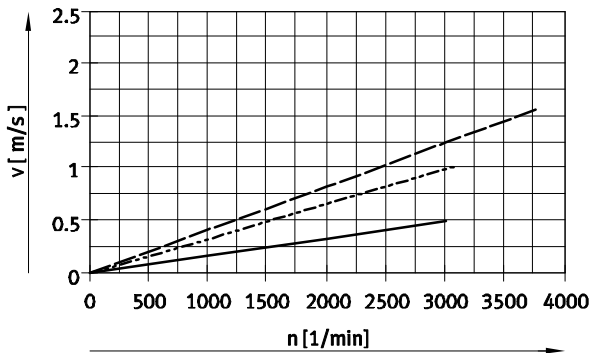

 Note  
Rotational speed is stroke-dependent.  
Note maximum rotational speed.

- EGC-HD-125/160/220-10P
- - - EGC-HD-160-20P
- · - EGC-HD-220-25P



# Spindle axes EGC-HD-BS, with heavy-duty guide

Technical data

## Maximum acceleration $a$ as a function of applied load $m$

Size 125

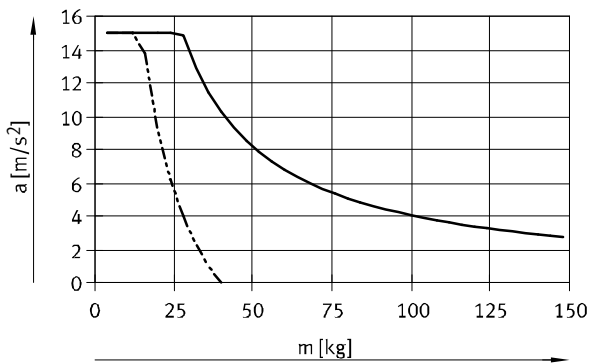

Size 160

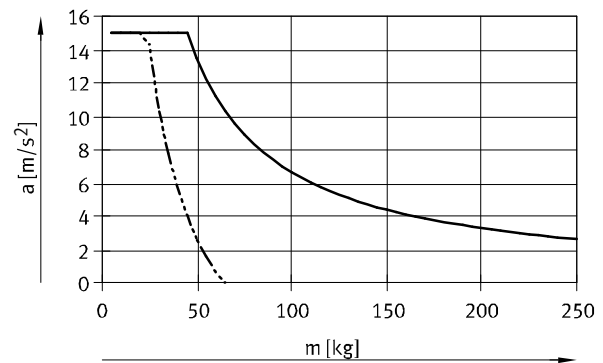

Size 220

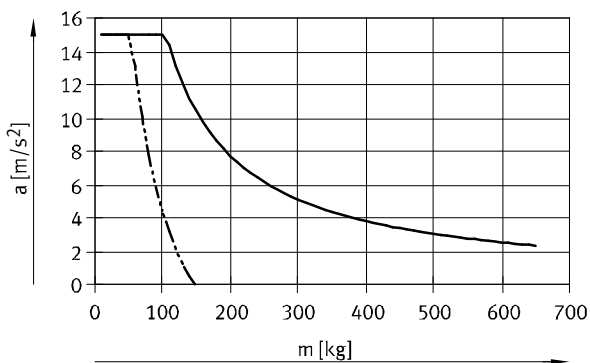

— Horizontal mounting position  
 - - - Vertical mounting position

## Theoretical feed force $F$ as a function of input torque $M$

Size 125

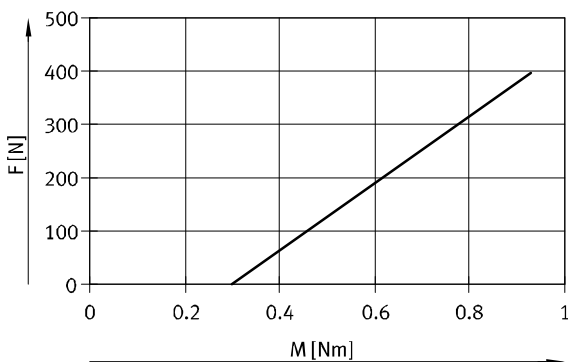

— EGC-HD-125-10P

Size 160

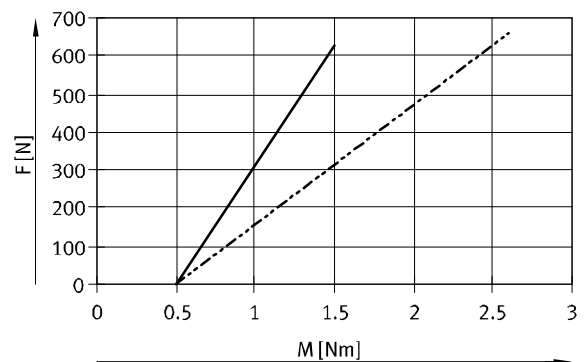

— EGC-HD-160-10P  
 - - - EGC-HD-160-20P

Size 220

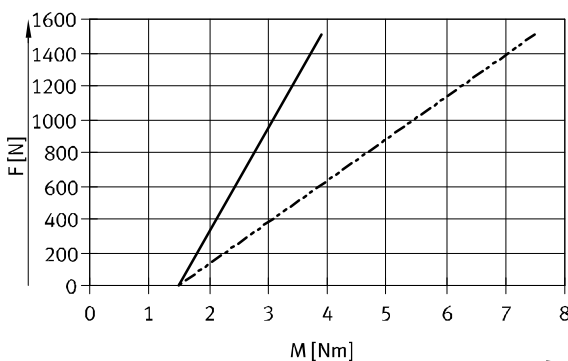

— EGC-HD-220-10P  
 - - - EGC-HD-220-25P

# Spindle axes EGC-HD-BS, with heavy-duty guide

Technical data

## Stroke reserve

Stroke length	Stroke reserve		
The selected stroke corresponds in principle to the required working stroke. The variant GK does not have a long-term lubrication unit on the guide. These variants therefore additionally have a safety distance between the drive cap and slide that is not designated as part of the working stroke.	A safety distance (similar to GK) between the drive cap and slide can be defined for the variants GP using the modular product system via the stroke reserve feature. With the variants GK, the stroke reserve and safety distance are added for each end position.	<ul style="list-style-type: none"> <li>The stroke reserve length can be freely selected</li> <li>The sum of the stroke length and 2x stroke reserve must not exceed the maximum working stroke</li> </ul>	<b>Example:</b> Type: EGC-HD-125-500-BS-20H-... Working stroke = 500 mm 2x stroke reserve = 40 mm Total stroke = 540 mm (540 mm = 500 mm + 2x 20 mm)

Size	125	160	220
L = safety distance with GK [mm] (per end position)	12.5	15.5	20

## Working stroke reduction

With standard slide GK/GP with additional slide KL/KR

- With a spindle axis with additional slide, the working stroke is reduced by the length of the additional slide L17 and the distance between both slides L18
- If the variant GP is ordered, the additional slide is also protected

L16 = Length of slide  
 L17 = Length of additional slide  
 L18 = Distance between both slides

**Example:**  
 Type: EGC-HD-220-1000-BS-...-GP-KR  
 L18 = 100 mm

Working stroke = 1000 mm – 328 mm – 100 mm = 572 mm

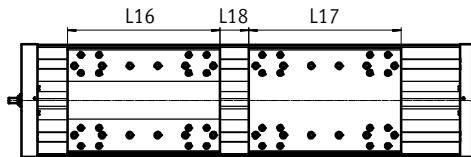

## Dimensions – Additional slide

Size	125	160	220
Variant	GK	GK	GP
Length L17 [mm]	202	220	250

## Working stroke reduction per side

With integrated emergency buffer NPE with retainer EAYH-L2

- With a spindle axis, the working stroke is reduced by the total dimension of the emergency buffer and retainer.

Size	125	160	220
With emergency buffer [mm]	65	93	98

# Spindle axes EGC-HD-BS, with heavy-duty guide

Technical data

## Second moment of area

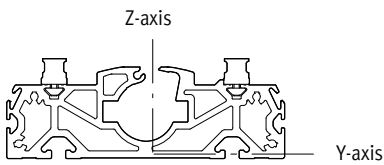

Size		125	160	220
$I_y$	[mm <sup>4</sup> ]	$7.15 \times 10^5$	$13.5 \times 10^5$	$55.7 \times 10^5$
$I_z$	[mm <sup>4</sup> ]	$41.1 \times 10^5$	$101 \times 10^5$	$352 \times 10^5$

## Maximum permissible support spacing L (without profile mounting) as a function of force F

In order to limit deflection in the case of large strokes, the axis may need to be supported.

The following graphs help to determine the maximum permissible support spacing l as a function of force F acting on the axis. The deflection is  $f = 0.5$  mm.

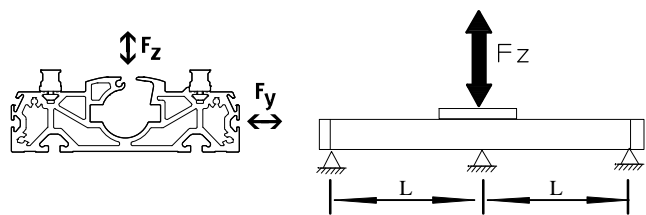

Force Fy

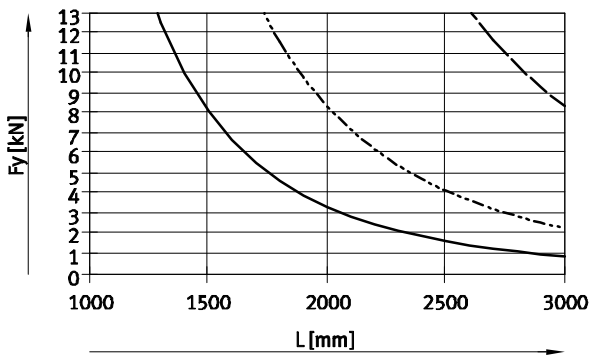

Force Fz

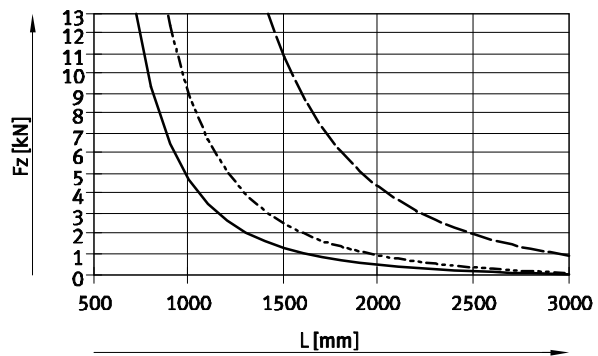

- EGC-HD-125
- - - EGC-HD-160
- · - EGC-HD-220

## Recommended deflection limits

Adherence to the following deflection limits is recommended so as not to impair the functional performance of the axes. Greater deformation can result in increased friction, greater wear and reduced service life.

Size	Dyn. deflection (moving load)	Stat. deflection (stationary load)
125 ... 220	0.05% of the axis length, max. 0.5 mm	0.1% of the axis length

# Spindle axes EGC-HD-BS, with heavy-duty guide

Technical data

FESTO

## Dimensions

Download CAD data → [www.festo.com](http://www.festo.com)

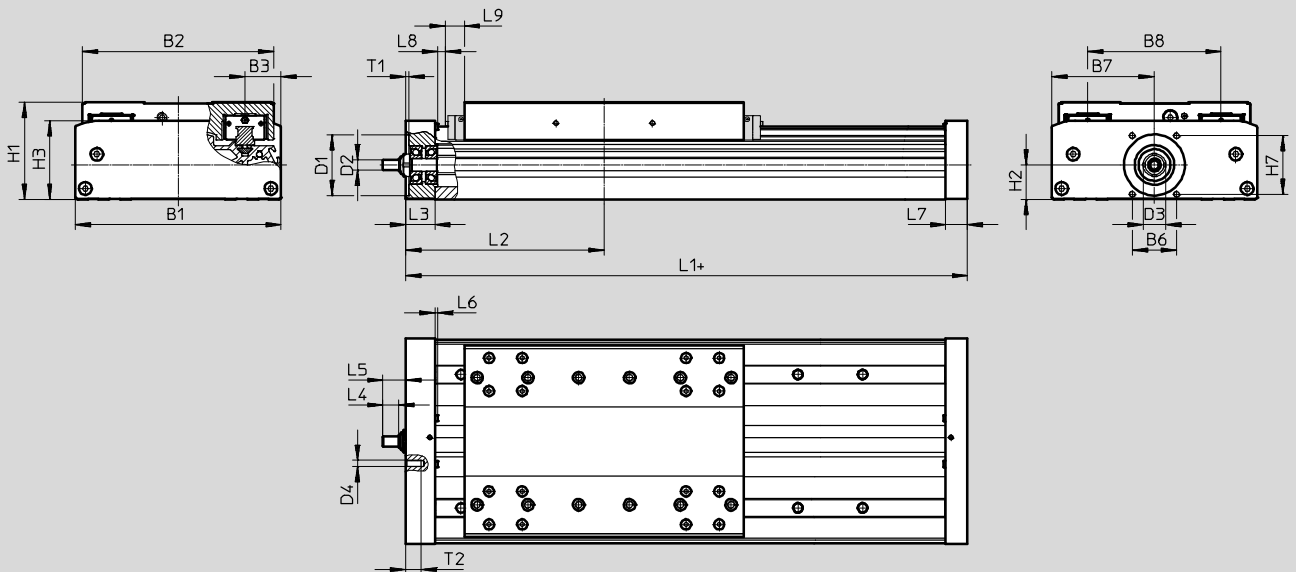

+ = plus stroke length + 2x stroke reserve

L9 With GP: dimension for long-term lubrication unit → page 18

Size	B1	B2	B3	B6	B7	B8	D1 ∅ H7	D2 ∅ h6
125	124	120	21	29	62	80	38	6
160	162	150.7	27.5	35	81	105	48	8
220	224	204.2	40	64	112	140	62	12

Size	D3	D4	H1	H2	H3	H7	L3	L4
125	15	M5	64	22.5	50.4	36	21	8
160	18	M5	76.5	27	62	46	23	12.5
220	28	M6	111.5	42.5	91	54	33	17.5

Size	L5	L6	L7	L8	L9	T1	T2
125	14	1.8	16	2	-	2.5	12
160	18	2	17	0.55	14.9	2.5	12
220	25.5	2	30	2	18	3	15

Size	Stroke	L1	L2 min.
125	≤900	268	136.5
160	<1377	296	151.3
	≥1377	336	171
220	<1604	409	206
	≥1604	469	236

# Spindle axes EGC-HD-BS, with heavy-duty guide

Technical data

## Dimensions

Download CAD data → [www.festo.com](http://www.festo.com)

### Profile

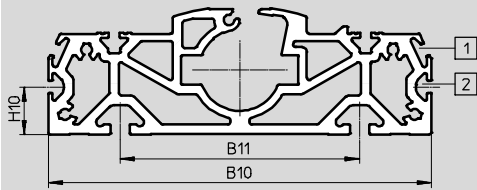

- 1 Sensor slot for proximity sensor
- 2 Mounting slot for slot nut

Size	B10	B11	H10
125	122	80	20
160	160	100	20
220	220	140	20

### GK – Standard slide

#### Size 125

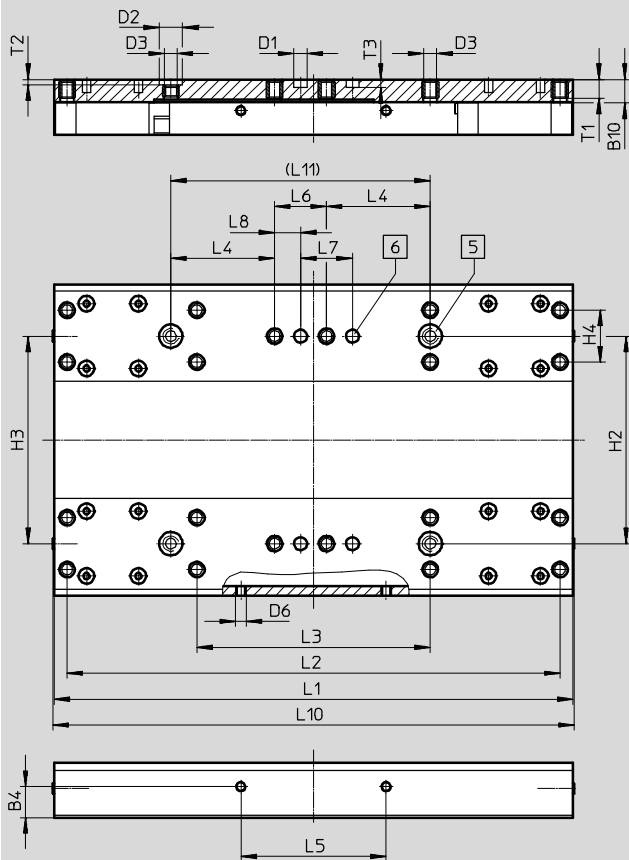

- 5 Hole for centring sleeve ZBH
- 6 Hole for centring pin ZBS

Size	B4	B10	D1	D2	D3	D6	H2	H3	H4	L1	L2	L3
	±0.1		∅ H7	∅ H7			±0.03	±0.05	±0.1	±0.1	±0.2	±0.1
125	12	9	5	9	M5	M4	80	80	20	200	190	90

Size	L4	L5	L6	L7	L8	L10	L11	T1	T2	T3
	±0.1	±0.2	±0.1	±0.03	±0.1		±0.03		+0.1	+0.1
125	40	56	20	20	10	202	100	7.8	2.1	3.1

# Spindle axes EGC-HD-BS, with heavy-duty guide

Technical data

FESTO

## Dimensions

Download CAD data → [www.festo.com](http://www.festo.com)

GK – Standard slide/GP – Standard slide, protected

### Size 160

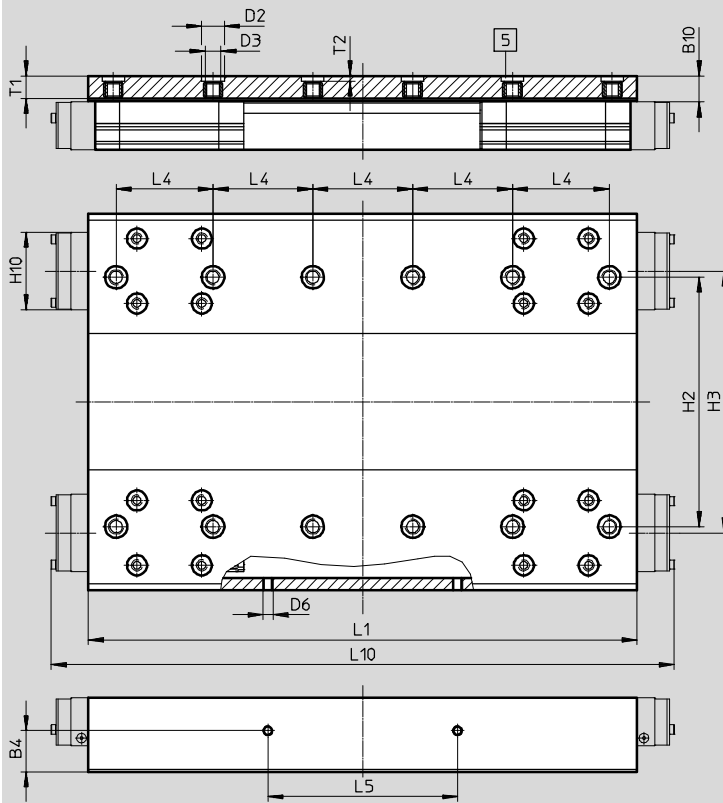

5 Hole for centring sleeve ZBH

Size	B4	B10 <sup>*)</sup>	D2 ∅ H7	D3	D6	H2 ±0.03	H3 ±0.05
160	16.5	10.5	9	M6	M4	100	105

Size	H10 <sup>*)</sup>	L1 ±0.1	L4 ±0.03	L5 ±0.1	L10 <sup>*)</sup>	T1	T2 +0.1
160	31	220	40	76	250	9	2.1

<sup>\*)</sup> Protected version

# Spindle axes EGC-HD-BS, with heavy-duty guide

Technical data

## Dimensions

Download CAD data → [www.festo.com](http://www.festo.com)

GK – Standard slide/GP – Standard slide, protected

### Size 220

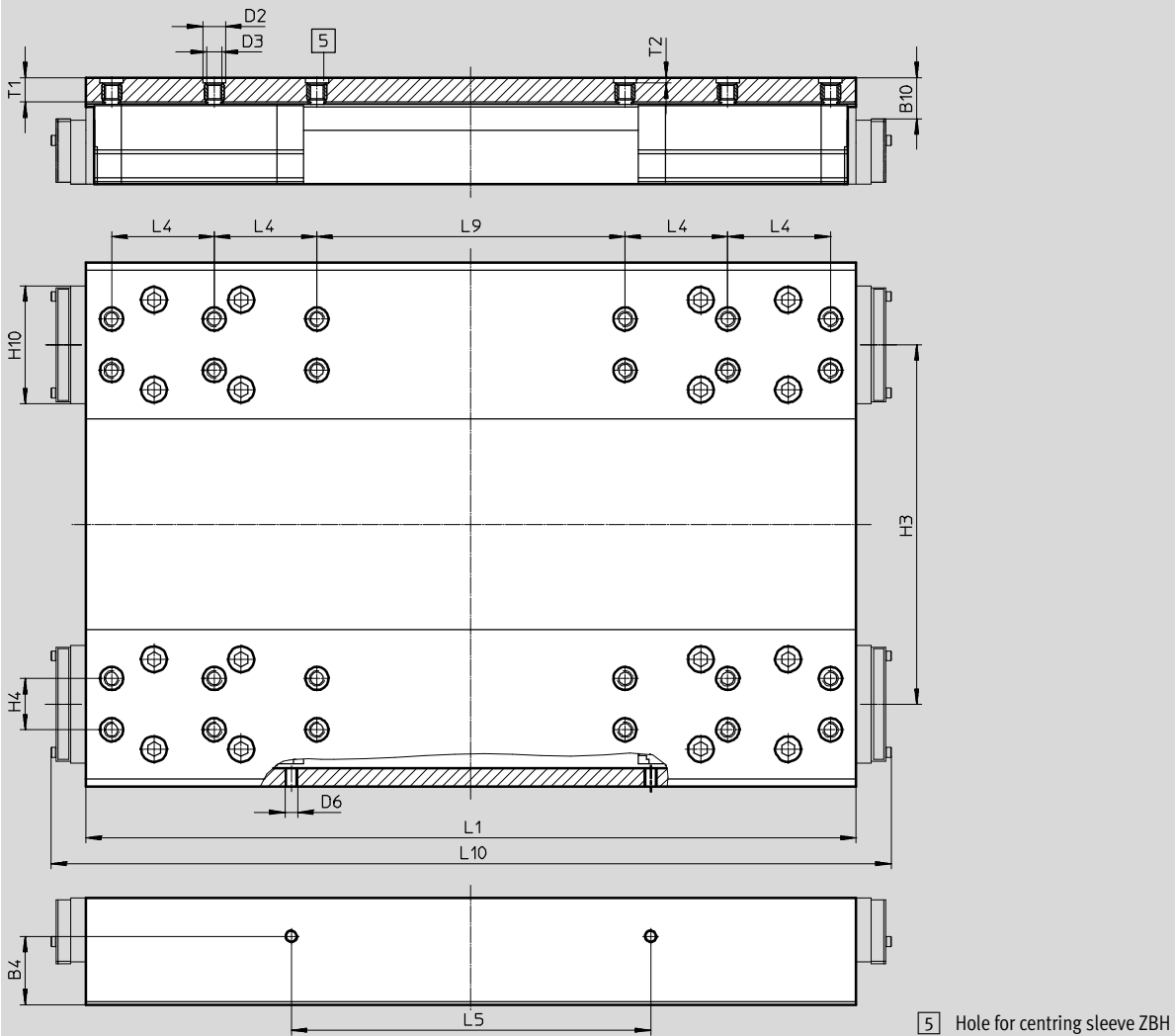

Size	B4	B10 <sup>*)</sup>	D2 ∅ H7	D3	D6	H3	H4	H10 <sup>*)</sup>
220	±0.1	16	9	M6	M5	±0.05	±0.03	45.95

Size	L1	L4	L5	L9	L10 <sup>*)</sup>	T1	T2
220	±0.1	±0.03	±0.1	±0.03	328	9.5	+0.1

<sup>\*)</sup> Protected version

# Spindle axes EGC-HD-BS, with heavy-duty guide

Ordering data – Modular products



## Order code

Mandatory data

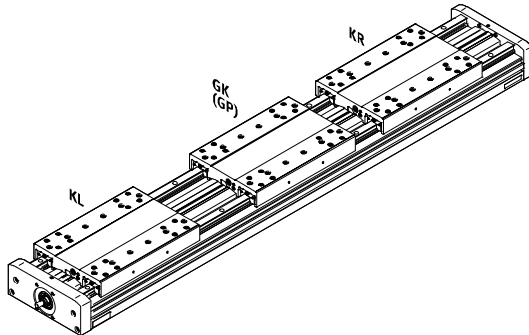
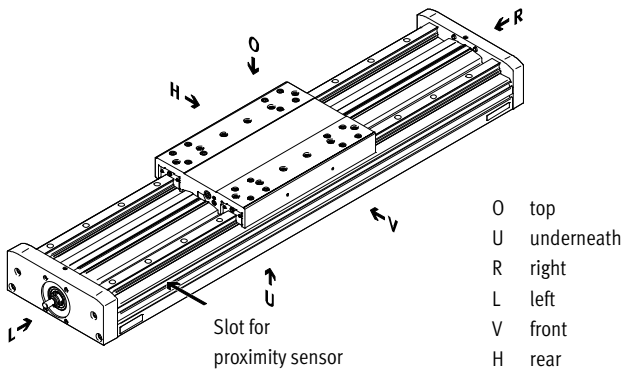

## Accessories

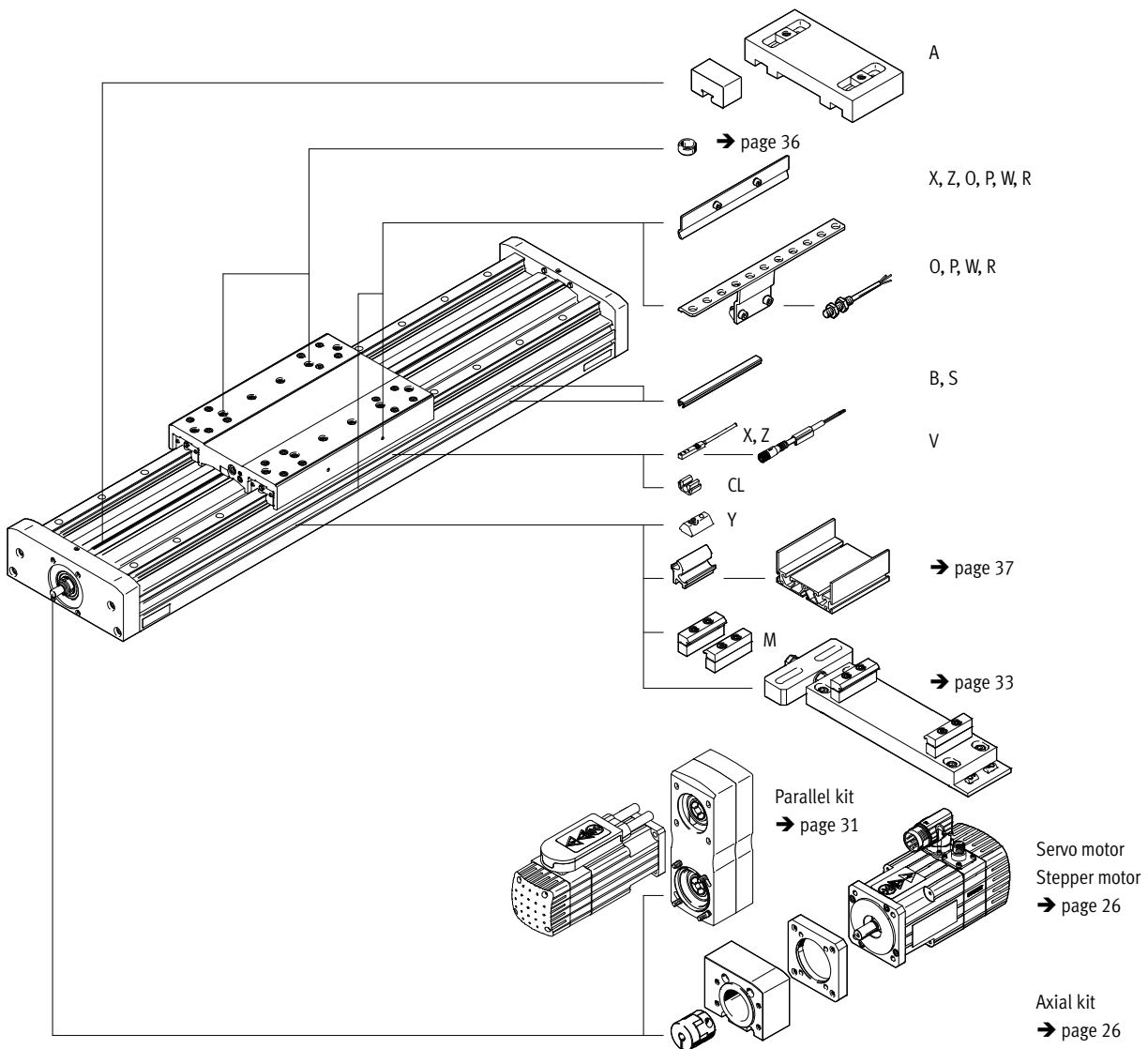



# Spindle axes EGC-HD-BS, with heavy-duty guide

Ordering data – Modular products

Ordering table								
Size		125	160	220	Condi- tions	Code	Enter code	
<b>M</b> Module No.		<b>556819</b>	<b>556820</b>	<b>556821</b>				
Design		Linear axis				<b>EGC</b>	EGC	
Guide		Heavy-duty guide				<b>-HD</b>	-HD	
Size		125	160	220		-...	-...	
Stroke (without stroke reserve)	Standard [mm]	100; 200; 300; 400; 500; 600; 700; 900	100; 200; 300; 400; 500; 600; 700; 800; 900; 1300; 1400; 1700; 1900	100; 200; 300; 400; 500; 600; 700; 800; 900; 1300; 1400; 1900; 2400	[1]	-...	-...	
	Variable [mm]	50 ... 880	50 ... 1880	50 ... 2380				
Function		Ball screw spindle				<b>-BS</b>	-BS	
Spindle pitch		10	10	10		<b>-10P</b>		
		-	20	-		<b>-20P</b>		
		-	-	25		<b>-25P</b>		
<b>O</b> Spindle support		None						
		With spindle support			[4]	<b>-S</b>		
		> 605 mm	> 680 mm	> 783 mm				
<b>M</b> Stroke reserve [mm]		0 ... 999 (0 = no stroke reserve)			[1]	<b>-...H</b>		
Slide		Standard slide				<b>-GK</b>		
		-	Standard slide, protected			<b>-GP</b>		
<b>O</b> Additional slide	Left	Additional slide, standard, on left			[2]	<b>-KL</b>		
	Right	Additional slide, standard, on right			[2]	<b>-KR</b>		
Accessories		Accessories enclosed separately				<b>ZUB-</b>	ZUB-	
Profile mounting		1 ... 50				<b>...M</b>		
Cover	Mounting slot	1 ... 50 (1 = 2x 500 mm pieces)			[5]	<b>...B</b>		
	Sensor slot	1 ... 50				<b>...S</b>		
Slot nut for mounting slot		1 ... 99			[5]	<b>...Y</b>		
Proximity sensor (SIES), inductive, slot type 8, PNP, incl. switch lug	N/O contact, 7.5 m cable	1 ... 6				<b>...X</b>		
	N/C contact, 7.5 m cable	1 ... 6				<b>...Z</b>		
Emergency buffer with retainer		1 ... 2			[3]	<b>...A</b>		
Proximity sensor (SIEN), inductive, M8, PNP, incl. switch lug with sensor bracket	N/O contact, 2.5 m cable	1 ... 99				<b>...O</b>		
	N/C contact, 2.5 m cable	1 ... 99				<b>...P</b>		
	N/O contact, plug M8	1 ... 99				<b>...W</b>		
	N/C contact, plug M8	1 ... 99				<b>...R</b>		
Connecting cable, M8, 3-wire, 2.5 m		1 ... 99				<b>...V</b>		
Cable clip		10, 20, 30, 40, 50, 60, 70, 80, 90				<b>...CL</b>		
Operating instructions		Express waiver - no user documentation to be included (already available) (operating instructions in PDF format are available free of charge on the Internet at <a href="http://www.festo.com">http://www.festo.com</a> )				<b>-DN</b>		

[1] -... The sum of the stroke length and 2x the stroke reserve must not exceed the maximum stroke length.

[2] **KL, KR** If the protected slide variant (GP) is selected, then the additional slide (KL, KR) is also protected.

[3] ... **A** Cannot be combined with slide GP.

[4] **S** Only available above the specified strokes.

[5] **B, Y** Scope of delivery with size 160 for both slot sizes (→ page 36).

**M** Mandatory data

**O** Options

**Order code**

# Spindle axes EGC-HD-BS, with heavy-duty guide

Accessories

 Note  
 Depending on the combination of motor and drive, it may not be possible to reach the maximum feed force of the drive. The respective no-load driving torque of the kit must be taken into consideration when using parallel kits.

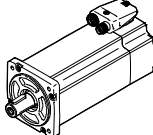
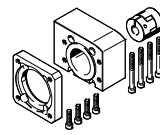
Permissible axis/motor combinations with axial kit		
Motor/gear unit <sup>1)</sup>	Axial kit	
		
Type	Part No.	Type
<b>EGC-HD-125</b>		
With servo motor		
EMME-AS-40-...	★ 3637972	EAMM-A-S38-40P-G2
EMMS-AS-40-...	3637971	EAMM-A-S38-40A-G2
EMMS-AS-55-...	3637967	EAMM-A-S38-55A-G2
EMMT-AS-60-...	★ 3637958	EAMM-A-S38-60P-G2
EMME-AS-60-...	★ 3637958	EAMM-A-S38-60P-G2
With servo motor and gear unit		
EMME-AS-40-... EMGA-40-P-G...-EAS-40	1456647	EAMM-A-S38-40G-G2
EMMS-AS-40-... EMGA-40-P-G...-SAS-40	1456647	EAMM-A-S38-40G-G2
With servo motor and angled gear unit		
EMME-AS-40-... EMGA-40-A-G...-40P	1456647	EAMM-A-S38-40G-G2
With stepper motor		
EMMS-ST-42-...	★ 3637965	EAMM-A-S38-42A-G2
EMMS-ST-57-...	★ 3637956	EAMM-A-S38-57A-G2
With stepper motor and gear unit		
EMMS-ST-42-... EMGA-40-P-G...-SST-42	1456647	EAMM-A-S38-40G-G2
With integrated drive		
EMCA-EC-67-...	1456638	EAMM-A-S38-67A-G2
With integrated drive and gear unit		
EMCA-EC-67-... EMGC-40-...	1456647	EAMM-A-S38-40G-G2

1) The input torque must not exceed the maximum permissible transferable torque of the axial kit.

Festo core product range

- ★ Generally ready for shipping ex works in 24 hours
- ☆ Generally ready for shipping ex works in 5 days

# Spindle axes EGC-HD-BS, with heavy-duty guide

Accessories

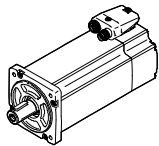
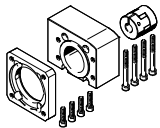
Permissible axis/motor combinations with axial kit		Technical data → Internet: eamm-a
Motor/gear unit <sup>1)</sup>	Axial kit	
		
Type	Part No.	Type
<b>EGC-HD-160</b>		
With servo motor		
EMMS-AS-55-...	3637961	EAMM-A-S48-55A-G2
EMMT-AS-60-...	★ 3637964	EAMM-A-S48-60P-G2
EMME-AS-60-...	★ 3637964	EAMM-A-S48-60P-G2
EMMS-AS-70-...	3637957	EAMM-A-S48-70A-G2
With servo motor and gear unit		
EMME-AS-40-...	1456650	EAMM-A-S48-40G-G2
EMGA-40-P-G...-EAS-40		
EMMS-AS-40-...	1456650	EAMM-A-S48-40G-G2
EMGA-40-P-G...-SAS-40		
EMMS-AS-55-...	2256701	EAMM-A-S48-60G-G2
EMGA-60-P-G...-SAS-55		
EMMT-AS-60-...	1456652	EAMM-A-S48-60H-G2
EMGA-60-P-G...-EAS-60		
EMME-AS-60-...	1456652	EAMM-A-S48-60H-G2
EMGA-60-P-G...-EAS-60		
EMMS-AS-70-...	2256701	EAMM-A-S48-60G-G2
EMGA-60-P-G...-SAS-70		
With servo motor and angled gear unit		
EMME-AS-40-...	1456650	EAMM-A-S48-40G-G2
EMGA-40-A-G...-40P		
EMMT-AS-60-...	1456652	EAMM-A-S48-60H-G2
EMGA-60-A-G...-60P		
EMME-AS-60-...	1456652	EAMM-A-S48-60H-G2
EMGA-60-A-G...-60P		
With stepper motor		
EMMS-ST-57-...	★ 3637963	EAMM-A-S48-57A-G2
EMMS-ST-87-...	★ 3637962	EAMM-A-S48-87A-G2
With stepper motor and gear unit		
EMMS-ST-42-...	1456650	EAMM-A-S48-40G-G2
EMGA-40-P-G...-SST-42		
EMMS-ST-57-...	2256701	EAMM-A-S48-60G-G2
EMGA-60-P-G...-SST-57		
With integrated drive and gear unit		
EMCA-EC-67-...	1456650	EAMM-A-S48-40G-G2
EMGC-40-...		
EMCA-EC-67-...	1456652	EAMM-A-S48-60H-G2
EMGC-60-...		

1) The input torque must not exceed the maximum permissible transferable torque of the axial kit.

Festo core product range

- ★ Generally ready for shipping ex works in 24 hours
- ☆ Generally ready for shipping ex works in 5 days

# Spindle axes EGC-HD-BS, with heavy-duty guide

Accessories

FESTO

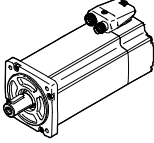
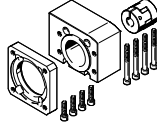
Permissible axis/motor combinations with axial kit		Technical data → Internet: eamm-a
Motor/gear unit <sup>1)</sup>	Axial kit	
		
Type	Part No.	Type
<b>EGC-HD-220</b>		
With servo motor		
EMMS-AS-70-...	3637959	EAMM-A-S62-70A-G2
EMME-AS-80-...	★ 3637970	EAMM-A-S62-80P-G2
EMME-AS-100-...	★ 3637960	EAMM-A-S62-100A-G2
EMMS-AS-100-...	★ 3637960	EAMM-A-S62-100A-G2
EMMS-AS-140-...	★ 3637969	EAMM-A-S62-140A-G2
With servo motor and gear unit		
EMMS-AS-55-... EMGA-60-P-G...-SAS-55	2297649	EAMM-A-S62-60G-G2
EMMT-AS-60-... EMGA-60-P-G...-EAS-60	1456654	EAMM-A-S62-60H-G2
EMME-AS-60-... EMGA-60-P-G...-EAS-60	1456654	EAMM-A-S62-60H-G2
EMMS-AS-70-... EMGA-60-P-G...-SAS-70	2297649	EAMM-A-S62-60G-G2
EMMS-AS-70-... EMGA-80-P-G...-SAS-70	1972530	EAMM-A-S62-80G-G2
EMME-AS-80-... EMGA-80-P-G...-EAS-80	1972530	EAMM-A-S62-80G-G2
EMME-AS-100-... EMGA-80-P-G...-SAS-100	1972530	EAMM-A-S62-80G-G2
EMMS-AS-100-... EMGA-80-P-G...-SAS-100	1972530	EAMM-A-S62-80G-G2
With servo motor and angled gear unit		
EMMT-AS-60-... EMGA-60-A-G...-60P	1456654	EAMM-A-S62-60H-G2
EMME-AS-60-... EMGA-60-A-G...-60P	1456654	EAMM-A-S62-60H-G2
EMME-AS-80-... EMGA-80-A-G...-80P	1972530	EAMM-A-S62-80G-G2
EMME-AS-100-... EMGA-80-A-G...-100A	1972530	EAMM-A-S62-80G-G2
With stepper motor		
EMMS-ST-87-...	★ 3637966	EAMM-A-S62-87A-G2
With stepper motor and gear unit		
EMMS-ST-57-... EMGA-60-P-G...-SST-57	2297649	EAMM-A-S62-60G-G2
EMMS-ST-87-... EMGA-80-P-G...-SST-87	1972530	EAMM-A-S62-80G-G2
With integrated drive and gear unit		
EMCA-EC-67-... EMGC-60-...	1456654	EAMM-A-S62-60H-G2
EMCA-EC-67-... EMGC-80-...	1972530	EAMM-A-S62-80G-G2





1) The input torque must not exceed the maximum permissible transferable torque of the axial kit.

Festo core product range

- ★ Generally ready for shipping ex works in 24 hours
- ☆ Generally ready for shipping ex works in 5 days

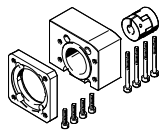
# Spindle axes EGC-HD-BS, with heavy-duty guide

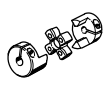
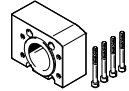
Accessories

Component parts of the axial kit – without gear unit				
Axial kit	Comprises:			
	Motor flange	Coupling	Coupling housing	Screw set
				
Part No. Type	Part No. Type	Part No. Type	Part No. Type	Part No. Type
<b>EGC-HD-125</b>				
3637971 EAMM-A-S38-40A-G2	558175 EAMF-A-38B-40A	558312 EAMC-30-32-6-6	3637942 EAMK-A-S38-38A/B-G2	–
1456647 EAMM-A-S38-40G-G2	1460097 EAMF-A-38A-40G	562681 EAMC-30-32-6-10	3637942 EAMK-A-S38-38A/B-G2	567488 EAHM-L2-M5-50
★ 3637972 EAMM-A-S38-40P-G2	2219077 EAMF-A-38B-40P	533708 EAMC-30-32-6-8	3637942 EAMK-A-S38-38A/B-G2	–
★ 3637965 EAMM-A-S38-42A-G2	560691 EAMF-A-38B-42A	561333 EAMC-30-32-5-6	3637942 EAMK-A-S38-38A/B-G2	–
3637967 EAMM-A-S38-55A-G2	558176 EAMF-A-38A-55A	551003 EAMC-30-32-6-9	3637942 EAMK-A-S38-38A/B-G2	567488 EAHM-L2-M5-50
★ 3637956 EAMM-A-S38-57A-G2	560692 EAMF-A-38A-57A	551002 EAMC-30-32-6-6.35	3637942 EAMK-A-S38-38A/B-G2	567488 EAHM-L2-M5-50
★ 3637958 EAMM-A-S38-60P-G2	1987412 EAMF-A-38A-60P	1233256 EAMC-30-32-6-14	3637942 EAMK-A-S38-38A/B-G2	567489 EAHM-L2-M5-55
1456638 EAMM-A-S38-67A-G2	1490100 EAMF-A-38A-67A	551003 EAMC-30-32-6-9	3637942 EAMK-A-S38-38A/B-G2	567489 EAHM-L2-M5-55
<b>EGC-HD-160</b>				
1456650 EAMM-A-S48-40G-G2	4067069 EAMF-A-48B-40G	558029 EAMC-30-32-8-10	3637941 EAMK-A-S48-48A/B-G2	–
3637961 EAMM-A-S48-55A-G2	558177 EAMF-A-48B-55A	543423 EAMC-30-32-8-9	3637941 EAMK-A-S48-48A/B-G2	–
★ 3637963 EAMM-A-S48-57A-G2	560694 EAMF-A-48B-57A	543421 EAMC-30-32-6.35-8	3637941 EAMK-A-S48-48A/B-G2	–
2256701 EAMM-A-S48-60G-G2	558019 EAMF-A-48A-60G/H	551004 EAMC-30-32-8-11	3637941 EAMK-A-S48-48A/B-G2	567489 EAHM-L2-M5-55
1456652 EAMM-A-S48-60H-G2	558019 EAMF-A-48A-60G/H	562682 EAMC-30-32-8-14	3637941 EAMK-A-S48-48A/B-G2	567489 EAHM-L2-M5-55
★ 3637964 EAMM-A-S48-60P-G2	2220620 EAMF-A-48A-60P	562682 EAMC-30-32-8-14	3637941 EAMK-A-S48-48A/B-G2	567489 EAHM-L2-M5-55
3637957 EAMM-A-S48-70A-G2	558025 EAMF-A-48A-70A	551004 EAMC-30-32-8-11	3637941 EAMK-A-S48-48A/B-G2	567488 EAHM-L2-M5-50
★ 3637962 EAMM-A-S48-87A-G2	560695 EAMF-A-48A-87A	551004 EAMC-30-32-8-11	3637941 EAMK-A-S48-48A/B-G2	567489 EAHM-L2-M5-55





Festo core product range

★ Generally ready for shipping ex works in 24 hours

☆ Generally ready for shipping ex works in 5 days

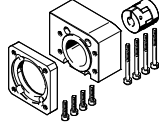
# Spindle axes EGC-HD-BS, with heavy-duty guide

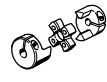
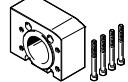
Accessories

Component parts of the axial kit – without gear unit				
Axial kit	Comprises:			
	Motor flange	Coupling	Coupling housing	Screw set
				
Part No. Type	Part No. Type	Part No. Type	Part No. Type	Part No. Type
<b>EGC-HD-220</b>				
2297649 EAMM-A-S62-60G-G2	1460112 EAMF-A-62A-60G/H	525864 EAMC-40-66-11-12	3637940 EAMK-A-S62-62A/B-G2	567495 EAHM-L2-M6-90
1456654 EAMM-A-S62-60H-G2	1460112 EAMF-A-62A-60G/H	1452803 EAMC-40-66-12-14	3637940 EAMK-A-S62-62A/B-G2	567495 EAHM-L2-M6-90
3637959 EAMM-A-S62-70A-G2	558179 EAMF-A-62B-70A	558313 EAMC-42-66-11-12	3637940 EAMK-A-S62-62A/B-G2	–
1972530 EAMM-A-S62-80G-G2	2116672 EAMF-A-62B-80G	2138701 EAMC-42-50-12-20	3637940 EAMK-A-S62-62A/B-G2	–
★ 3637970 EAMM-A-S62-80P-G2	2222624 EAMF-A-62B-80P	551005 EAMC-42-50-12-19	3637940 EAMK-A-S62-62A/B-G2	–
3637966 EAMM-A-S62-87A-G2	560696 EAMF-A-62B-87A	558313 EAMC-42-66-11-12	3637940 EAMK-A-S62-62A/B-G2	–
★ 3637960 EAMM-A-S62-100A-G2	558026 EAMF-A-62A-100A	551005 EAMC-42-50-12-19	3637940 EAMK-A-S62-62A/B-G2	567494 EAHM-L2-M6-80
★ 3637969 EAMM-A-S62-140A-G2	558022 EAMF-A-62A-140A	558314 EAMC-42-50-12-24	3637940 EAMK-A-S62-62A/B-G2	567495 EAHM-L2-M6-90

Festo core product range

★ Generally ready for shipping ex works in 24 hours

☆ Generally ready for shipping ex works in 5 days

# Spindle axes EGC-HD-BS, with heavy-duty guide

Accessories

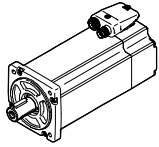
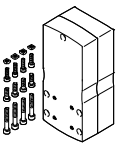
Permissible axis/motor combinations with parallel kit		Technical data → Internet: eamm-u
Motor/gear unit <sup>1)</sup>	Parallel kit	
		<ul style="list-style-type: none"> <li>• These parallel kits include a counter bearing EAMG for supporting the axis shaft. More information → online: eamm-u</li> <li>• Use in combination with third-party motors on request</li> </ul>
Type	Part No.	Type
<b>EGC-HD-125</b>		
With servo motor		
EMME-AS-40-...	2155239	EAMM-U-50-S38-40P-78
EMMS-AS-40-...	1217708	EAMM-U-50-S38-40A-78
EMMS-AS-55-...	1218538	EAMM-U-60-S38-55A-91
With stepper motor		
EMMS-ST-42-...	1217945	EAMM-U-50-S38-42A-78
EMMS-ST-57-...	1218568	EAMM-U-60-S38-57A-91
With gear unit		
EMGA-40-P-...	2283732	EAMM-U-60-S38-40G-91
EMGC-40-P-...	2283732	EAMM-U-60-S38-40G-91
<b>EGC-HD-160</b>		
With servo motor		
EMMS-AS-55-...	1219370	EAMM-U-60-S48-55A-91
EMME-AS-60-...	2629253	EAMM-U-70-S48-60P-96
EMMS-AS-70-...	2787320	EAMM-U-70-S48-70A-96
EMMS-AS-70-...	1217689	EAMM-U-86-S48-70A-102
With stepper motor		
EMMS-ST-57-...	1219379	EAMM-U-60-S48-57A-91
EMMS-ST-87-...	1217604	EAMM-U-86-S48-87A-177
With gear unit		
EMGA-40-P-...	2283760	EAMM-U-60-S48-40G-91
EMGC-40-P-...	2283760	EAMM-U-60-S48-40G-91
EMGA-60-P-...-SAS/SST <sup>2)</sup>	2801627	EAMM-U-70-S48-60G-96
EMGA-60-P-...-EAS EMGC-60-P-... <sup>2)</sup>	2801715	EAMM-U-70-S48-60H-96
EMGA-60-P-...-SAS/SST <sup>2)</sup>	1587251	EAMM-U-86-S48-60G-102
EMGA-60-P-...-EAS EMGC-60-P-... <sup>2)</sup>	1587338	EAMM-U-86-S48-60H-102
<b>EGC-HD-220</b>		
With servo motor		
EMMS-AS-70-...	1217543	EAMM-U-86-S62-70A-177
EMME-AS-80-...	2157004	EAMM-U-86-S62-80P-177
EMME-AS-100-...	1217381	EAMM-U-110-S62-100A-207
EMMS-AS-100-...	1217381	EAMM-U-110-S62-100A-207
EMMS-AS-140-...	1219440	EAMM-U-145-S62-140A-288
With stepper motor		
EMMS-ST-87-...	1217373	EAMM-U-86-S62-87A-177
With gear unit		
EMGA-60-P-...-SAS/SST... <sup>2)</sup>	1587411	EAMM-U-86-S62-60G-177
EMGA-60-P-...-EAS EMGC-60-P-... <sup>2)</sup>	1587453	EAMM-U-86-S62-60H-177

1) The input torque must not exceed the maximum permissible transferable torque of the parallel kit.  
 2) Gear unit drive shaft diameter: EMGA-60-P-...-SAS/-SST11 mm; EMGA-60-P-...-EAS, EMGC-60-P14 mm

 Note  
 The clamping element EADT is required to adjust the toothed belt pretensioning for EAMM-U-110 and EAMM-U-145.

# Spindle axes EGC-HD-BS, with heavy-duty guide

Accessories



**Profile mounting MUE**  
(order code M)

Materials:  
Anodised aluminium  
RoHS-compliant

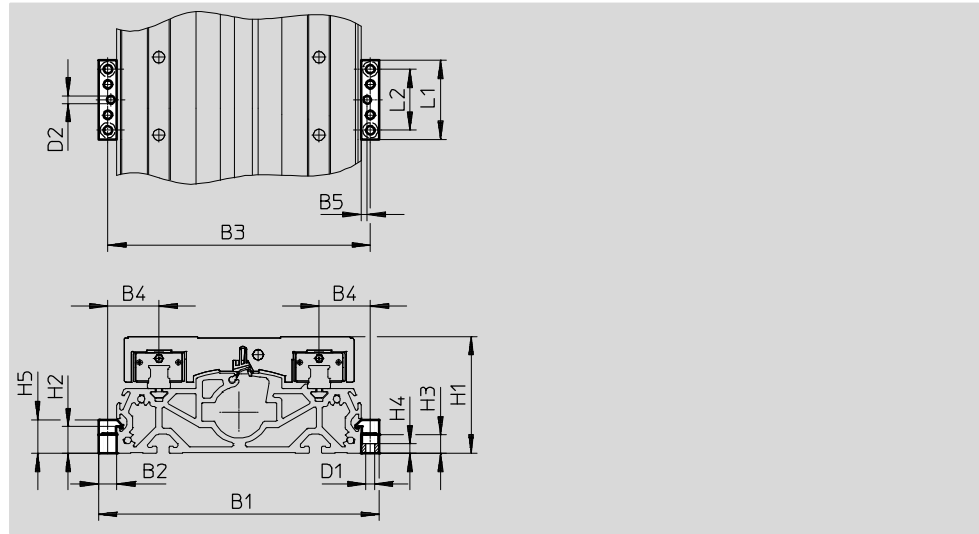
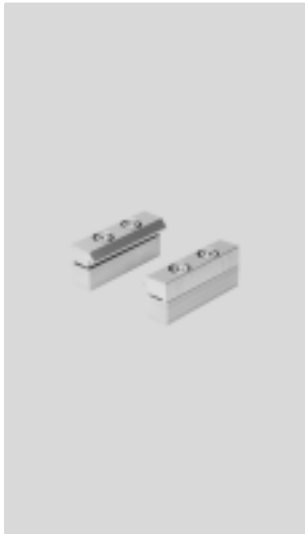

## Dimensions and ordering data

For size	B1	B2	B3	B4	B5	D1 ∅	D2 ∅ H7	H1	H2
125	146	12	134	27	4	5.5	5	64	17.5
160	184	12	172	33.5	4	5.5	5	76.5	17.5
220	258	19	239	49.5	4	9	5	111.5	16

For size	H3	H4	H5	L1	L2	Weight [g]	Part No.	Type
125	12	6.2	22	52	40	80	<b>558043</b>	<b>MUE-70/80</b>
160	12	6.2	22	52	40	80	<b>558043</b>	<b>MUE-70/80</b>
220	14	5.5	29.5	90	40	290	<b>558044</b>	<b>MUE-120/185</b>



# Spindle axes EGC-HD-BS, with heavy-duty guide

Accessories

## Adjusting kit EADC-E16

Materials:  
Wrought aluminium alloy  
RoHS-compliant

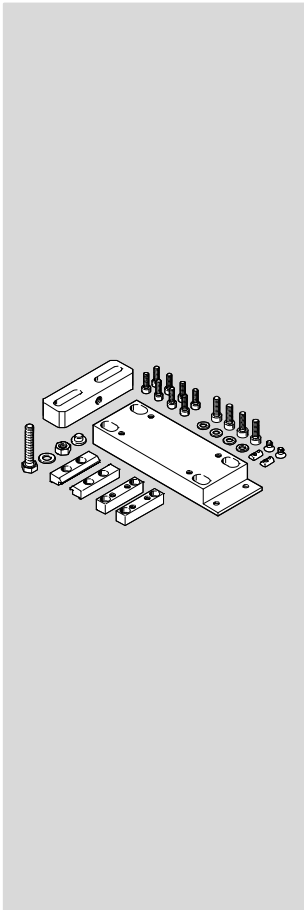

Size 125, 160

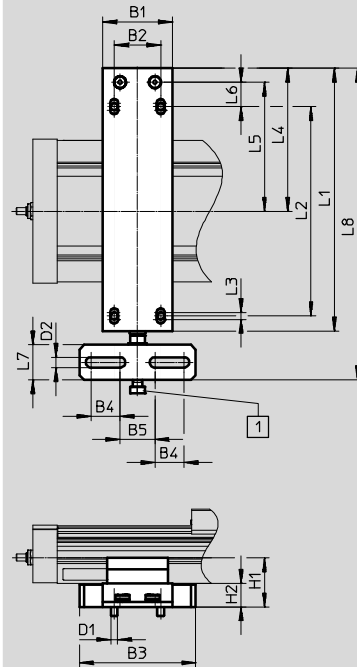

Size 220

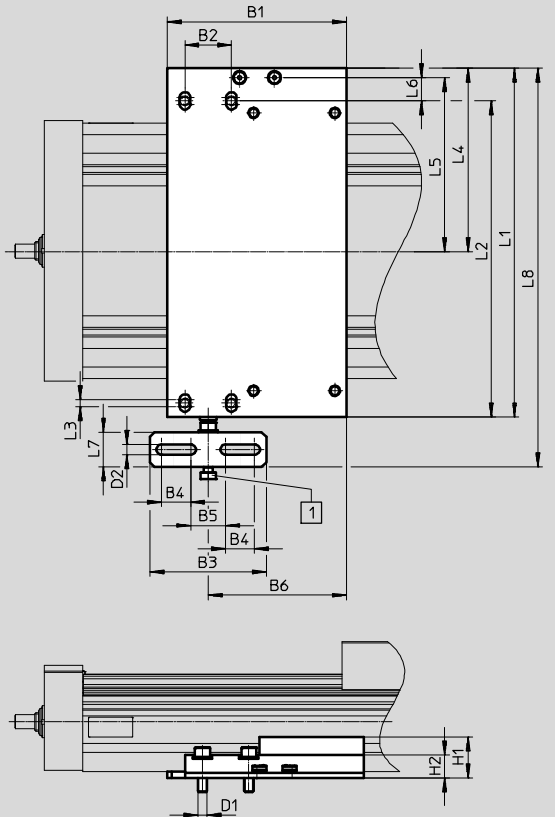

1 Screw M8

### Dimensions and ordering data

For size	B1	B2	B3	B4	B5	B6	D1	D2	H1	H2	L1	L2
125	60	40	100	25	30	-	M6	9	42	20	226	180
160	60	40	100	25	30	-	M6	9	44	22	266	220
220	154	40	100	25	30	119	M8	9	35.1	19.6	300	260

For size	L3	L4	L5	L6	L7	L8	Weight [g]	Part-No.	Type
125	6	123	111	21	30	308	974	8047580	EADC-E16-125-E14
160	6	143	131	21	30	343	1189	8047581	EADC-E16-160-E14
220	6	157.7	149.7	20	30	343	1500	8047582	EADC-E16-220-E14

# Spindle axes EGC-HD-BS, with heavy-duty guide

Accessories



## Retainer EAYH

Emergency buffer NPE → page 36  
(order code A)

Materials:

Anodised aluminium  
RoHS-compliant

Cannot be used in combination with  
the variants GP.

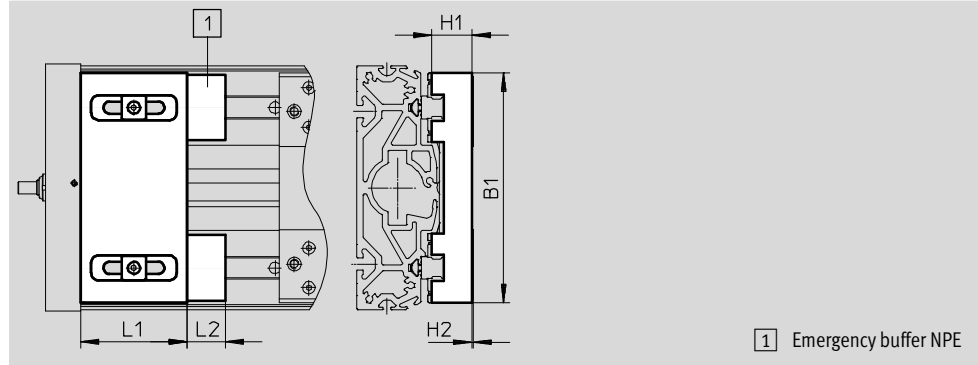
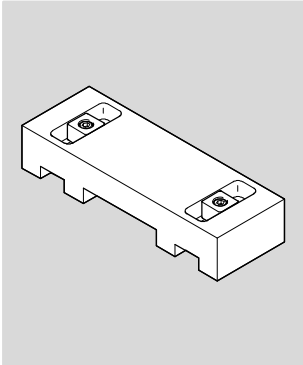

Dimensions and ordering data								
For size	B1	H1	H2	L1	L2	Weight [g]	Part No.	Type
125	120	19.8	0.4	50	17	260	1662803	EAYH-L2-125-N
160	150.7	26.2	0.8	70	25	617	1669259	EAYH-L2-160-N
220	204	38.7	0.1	70	30	1195	1669260	EAYH-L2-220-N

## Switch lug SF-EGC-HD-1

For sensing via proximity sensor  
SIES-8M  
(order code X or Z)

Materials:

Galvanised steel  
RoHS-compliant

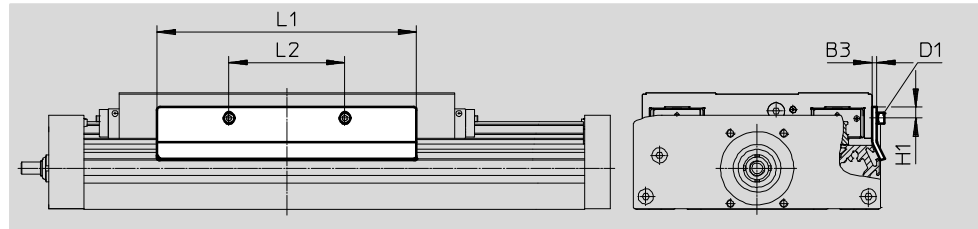

Dimensions and ordering data								
For size	B3	D1	H1	L1	L2	Weight [g]	Part No.	Type
125	2	M4x8	7.8	150	56	70	570027	SF-EGC-HD-1-125
160	3	M4x8	7.3	170	76	160	1645872	SF-EGC-HD-1-160
220	3	M5x10	11.5	250	140	310	1645866	SF-EGC-HD-1-220

# Spindle axes EGC-HD-BS, with heavy-duty guide

Accessories

## Switch lug SF-EGC-HD-2

For sensing via proximity sensor SIEN-M8B (order code O, P, W or R) or SIES-8M (order code X or Z)

Materials:  
Galvanised steel  
RoHS-compliant



## Sensor bracket HWS-EGC

For proximity sensor SIEN-M8B (order code O, P, W or R)

Materials:  
Galvanised steel  
RoHS-compliant

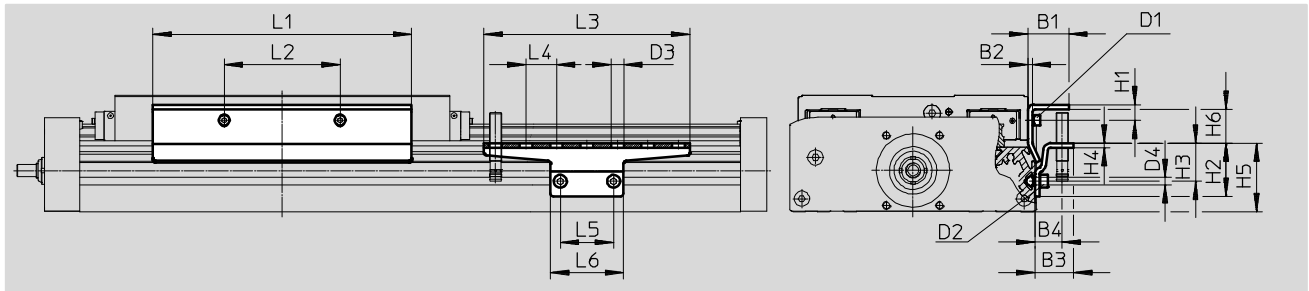

Dimensions and ordering data											
For size	B1	B2	B3	B4	D1	D2	D3	D4	H1	H2	
125	24	2	25.5	18	M4x8	M5x8	8.4	5.2	9	35	
160	27	3	25.5	18	M4x8	M5x8	8.4	5.2	10.3	35	
220	31	3	25.5	18	M5x10	M5x14	8.4	5.2	11.5	65	

For size	H3	H4	H5	H6	L1	L2	L3	L4	L5	L6
125	25	3	45	14	150	56	135	20	35	48
160	25	3	45	22.2	170	76	135	20	35	48
220	55	3	75	18.4	250	140	215	20	35	48





For size	Weight [g]	Part No.	Type
			Switch lug
125	122	570030	SF-EGC-HD-2-125
160	261	1645865	SF-EGC-HD-2-160
220	430	1645868	SF-EGC-HD-2-220

For size	Weight [g]	Part No.	Type
			Sensor bracket
125	110	558057	HWS-EGC-M5
160	110	558057	HWS-EGC-M5
220	217	570365	HWS-EGC-M8-B

# Spindle axes EGC-HD-BS, with heavy-duty guide

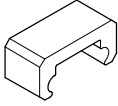
Accessories

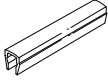
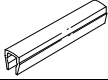
**FESTO**

Ordering data						
	For size	Comment	Order code	Part No.	Type	PU <sup>1)</sup>
<b>Emergency buffer NPE</b>						
	125	Use in combination with retainer EAYH	A	<b>1662475</b>	<b>NPE-125</b>	1
	160			<b>1672593</b>	<b>NPE-160</b>	
	220			<b>1672598</b>	<b>NPE-220</b>	
<b>Slot nut NST</b>						
	125, 160 <sup>2)</sup>	For mounting slot	Y	<b>150914</b>	<b>NST-5-M5</b>	1
				<b>8047843</b>	<b>NST-5-M5-10</b>	10
				<b>8047878</b>	<b>NST-5-M5-50</b>	50
	160 <sup>3)</sup> , 220	For mounting slot	Y	<b>150915</b>	<b>NST-8-M6</b>	1
				<b>8047868</b>	<b>NST-8-M6-10</b>	10
				<b>8047869</b>	<b>NST-8-M6-50</b>	50
<b>Centring pin/sleeve ZBS/ZBH</b>						
	125	For slide	-	<b>150928</b>	<b>ZBS-5</b>	10
	125, 160, 220			<b>150927</b>	<b>ZBH-9</b>	
<b>Slot cover ABP</b>						
	125, 160 <sup>2)</sup>	For mounting slot Every 0.5 m	B	<b>151681</b>	<b>ABP-5</b>	2
	160 <sup>3)</sup> , 220			<b>151682</b>	<b>ABP-8</b>	
<b>Slot cover ABP-S</b>						
	125, 160, 220	For sensor slot Every 0.5 m	S	<b>563360</b>	<b>ABP-5-S1</b>	2
<b>Clip SMBK</b>						
	125, 160, 220	For sensor slot, for attaching the proximity sensor cables	CL	<b>534254</b>	<b>SMBK-8</b>	10

- 1) Packaging unit quantity
- 2) For mounting slot at side
- 3) For mounting slot underneath

# Spindle axes EGC-HD-BS, with heavy-duty guide

Accessories



## Mounting options between axis and support profile

Depending on the adapter kit, the spacing between the axis and the support profile is:  
x = 20 mm or 50 mm

The support profile must be mounted using at least 2 adapter kits. For longer strokes, an adapter kit must be used every 500 mm.

Example:

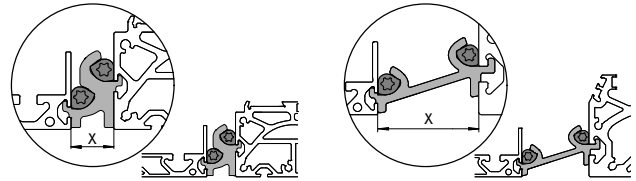

Ordering data					
	For size	Comment	Part No.	Type	PU <sup>1)</sup>
<b>Adapter kit DHAM</b>					
	160	<ul style="list-style-type: none"> <li>For mounting the support profile on the axis</li> <li>Spacing between axis and profile is 20 mm</li> </ul>	562241	DHAM-ME-N1-CL	1
	220		562242	DHAM-ME-N2-CL	
	125, 160	<ul style="list-style-type: none"> <li>For mounting the support profile on the axis</li> <li>Spacing between axis and profile is 50 mm</li> </ul>	574560	DHAM-ME-N1-50-CL	
	220		574561	DHAM-ME-N2-50-CL	
<b>Support profile HMIA</b>					
	125 ... 220	<ul style="list-style-type: none"> <li>For guiding an energy chain</li> </ul>	539379	HMIA-E07-	1





1) Packaging unit quantity



Ordering data – Proximity sensor for T-slot, inductive							Technical data → Internet: sies	
	Type of mounting	Electrical connection	Switching output	Cable length [m]	Order code	Part No.	Type	
<b>N/O contact</b>								
	Insertable in the slot from above, flush with the cylinder profile	Cable, 3-wire	PNP	7.5	X	551386	SIES-8M-PS-24V-K-7,5-OE	
		Plug connector M8x1, 3-pin		0.3	–	551387	SIES-8M-PS-24V-K-0,3-M8D	
		Cable, 3-wire	NPN	7.5	–	551396	SIES-8M-NS-24V-K-7,5-OE	
		Plug connector M8x1, 3-pin		0.3	–	551397	SIES-8M-NS-24V-K-0,3-M8D	
<b>N/C contact</b>								
	Insertable in the slot from above, flush with the cylinder profile	Cable, 3-wire	PNP	7.5	Z	551391	SIES-8M-PO-24V-K-7,5-OE	
		Plug connector M8x1, 3-pin		0.3	–	551392	SIES-8M-PO-24V-K-0,3-M8D	
		Cable, 3-wire	NPN	7.5	–	551401	SIES-8M-NO-24V-K-7,5-OE	
		Plug connector M8x1, 3-pin		0.3	–	551402	SIES-8M-NO-24V-K-0,3-M8D	

# Spindle axes EGC-HD-BS, with heavy-duty guide

Accessories

**FESTO**

Ordering data – Proximity sensors M8 (round design), inductive						Technical data → Internet: sien	
	Electrical connection	LED	Switching output	Cable length [m]	Order code	Part No.	Type
<b>N/O contact</b>							
	Cable, 3-wire	■	PNP	2.5	O	<b>150386</b>	<b>SIEN-M8B-PS-K-L</b>
			NPN	2.5	–	<b>150384</b>	<b>SIEN-M8B-NS-K-L</b>
	Plug connector M8x1, 3-pin	■	PNP	–	W	<b>150387</b>	<b>SIEN-M8B-PS-S-L</b>
			NPN	–	–	<b>150385</b>	<b>SIEN-M8B-NS-S-L</b>
<b>N/C contact</b>							
	Cable, 3-wire	■	PNP	2.5	P	<b>150390</b>	<b>SIEN-M8B-PO-K-L</b>
			NPN	2.5	–	<b>150388</b>	<b>SIEN-M8B-NO-K-L</b>
	Plug connector M8x1, 3-pin	■	PNP	–	R	<b>150391</b>	<b>SIEN-M8B-PO-S-L</b>
			NPN	–	–	<b>150389</b>	<b>SIEN-M8B-NO-S-L</b>

Ordering data – Connecting cables				Technical data → Internet: nebu	
	Electrical connection, left	Electrical connection, right	Cable length [m]	Part No.	Type
	Straight socket, M8x1, 3-pin	Cable, open end, 3-wire	2.5	<b>159420</b>	<b>SIM-M8-3GD-2,5-PU</b>
			2.5	<b>541333</b>	<b>NEBU-M8G3-K-2.5-LE3</b>
			5	<b>541334</b>	<b>NEBU-M8G3-K-5-LE3</b>
	Angled socket, M8x1, 3-pin	Cable, open end, 3-wire	2.5	<b>541338</b>	<b>NEBU-M8W3-K-2.5-LE3</b>
			5	<b>541341</b>	<b>NEBU-M8W3-K-5-LE3</b>