

Controller CMXH-ST2



Controller CMXH-ST2

Key features



At a glance

- The controller controls two servo motors which drive an H-shaped rotating toothed belt. The toothed belt moves a slide, whose position is calculated by the controller from the encoder signals of the motors
 - The motors are not directly assigned to an axis (X- or Y-axis) of the planar surface gantry. Instead, the movement of the slide towards an axis is achieved through the interaction of the two motors, which is controlled by the controller
 - Supports the safety function “safe torque off” (STO)
 - Easy actuation via:
 - Digital I/O interface
 - CAN interface
 - EtherNet TCP/IP – Modbus
 - H-rail mounting possible
- Parameterisation possible via:
- Configuration package FCT (Festo Configuration Tool)
 - Ethernet interface

Description of the interfaces

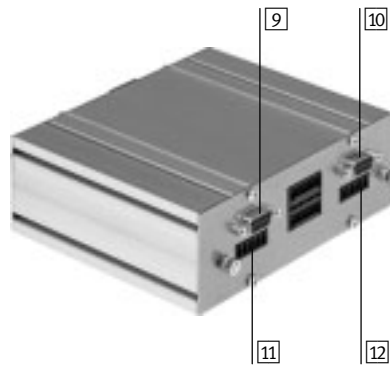
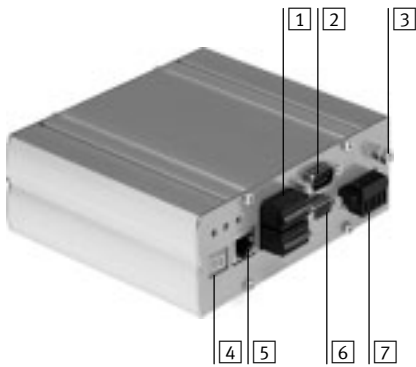

- 1** Switch-off functions
- 2** CAN interface
- 3** Functional earth
- 4** 7-segment display

- 5** Ethernet interface (RJ45)
- 6** I/O interface
- 7** Power supply

- 9** Encoder cable for motor 2
- 10** Encoder cable for motor 1
- 11** Motor cable 2
- 12** Motor cable 1

For controlling planar surface gantries

EXCM-30

EXCM-40



Controller CMXH-ST2

Key features



FCT software – Festo Configuration Tool

Software platform for electric drives from Festo



- All drives in a system can be managed and saved in a common project
- Project and data management for all supported device types
- Easy to use thanks to graphically supported parameter entry
- Universal mode of operation for all drives
- Work offline at your desk or online at the machine

Mechanical reference positions and limit positions



- Reference positions can be either edited or taught in
- Flexible adaptation to installation conditions
- Settings are displayed clearly

Record table



- 31 records ensure flexibility in positioning
- Absolute or relative positioning values can be used
- The following parameters can be set flexibly for each application:
 - Position
 - Speed
 - Acceleration
 - Jerk
- Complete function test

Controller CMXH-ST2

Type codes

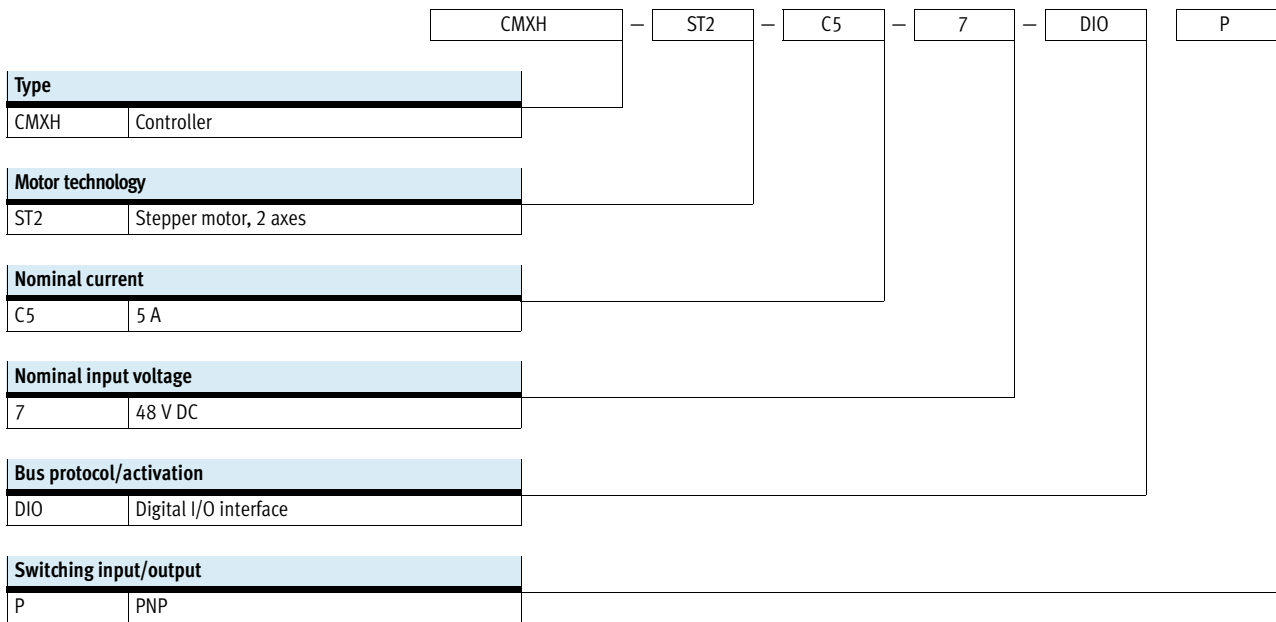

Controller CMXH-ST2

Technical data

FESTO



General technical data		
Supported kinematic systems		Planar surface gantry EXCM
Total number of axes		2
Operating mode		Direct operation
		Record selection
Status display		7-segment display
		LED
Device-specific diagnostics		System- and motor-oriented diagnostics
		Undervoltage, overvoltage, short circuit in motor winding
		Diagnostic memory
Rotary position encoder		Encoder
Configuration support		FCT (Festo Configuration Tool)
Braking resistor	[Ω]	15 (integrated)
Mains filter		Integrated
Type of mounting		With screws in the mounting slots
		With H-rail clip on H-rail
Product weight	[g]	700

Electrical data		
Load voltage		
Nominal voltage	[V DC]	24 ±10% or 48 ±10%
Nominal current	[A]	10
Maximum current	[A]	12
Logic supply		
Nominal voltage	[V DC]	24 ±15%
Maximum current		
Without brake	[A]	0.2
With brake	[A]	0.9
Maximum current per digital output	[A]	0.1
Mains buffering time ¹⁾	[ms]	10
Switching logic, input/output		PNP

1) Use of a brake reduces the mains buffering time. To achieve the time, a switched-mode power supply unit or a buffer module must be used in this case.

Controller CMXH-ST2

Technical data

Technical data – Fieldbus interface			
Interfaces	I/O	CANopen	Ethernet
Number of digital logic outputs	5	–	–
Number of digital logic inputs	8	–	–
Process interfacing	31 records		
Communication profile	–	FHPP	FHPP (via TCP/IP – Modbus)
Max. fieldbus transmission rate [Mbit/s]	–	1	100
Bus connection	Socket, 15-pin, Sub-D	Plug, 9-pin, Sub-D	RJ45

Safety data	
Safety function to EN 61800-5-2	Safe torque off (STO)
Performance Level (PL) to EN ISO 13849-1	Category 3, Performance Level e
Safety integrity level (SIL) to EN 61800-5-2, EN 62061, EN 61508	SIL CL 3/ SC 3
Certificate issuing authority	TÜV 01/205/5519.00/16
Proof test interval	20a
PFH [1/hr]	2×10^{-9}
Diagnostic coverage [%]	90
Safe failure fraction (SFF) [%]	99
Hardware fault tolerance	1
CE marking (see declaration of conformity)	To EU EMC Directive ¹⁾
	To EU Machinery Directive
Resistance to shock	To EN 60068-2-27
Resistance to vibration	To EN 60068-2-6

- 1) For information about the applicability of the component see the manufacturer's EC declaration of conformity at: www.festo.com/sp → Certificates.
If the component is subject to restrictions on usage in residential, office or commercial environments or small businesses, further measures to reduce the emitted interference may be necessary.

Operating and environmental conditions	
Characteristics of digital logic outputs	Not galvanically isolated
Degree of protection	IP20
Protection class	III
Ambient temperature [°C]	0 ... +50
Storage temperature [°C]	–25 ... +75
Relative air humidity [%]	0 ... 90 (non-condensing)
CE marking (see declaration of conformity)	To EU EMC Directive ¹⁾
	To EU Machinery Directive
Approval certificate	RCM trademark
Note on materials	RoHS-compliant

- 1) For information about the applicability of the component see the manufacturer's EC declaration of conformity at: www.festo.com/sp → Certificates.
If the component is subject to restrictions on usage in residential, office or commercial environments or small businesses, further measures to reduce the emitted interference may be necessary.
The EMC is only complied with in combination with the drive packages specified in the gantries (controller, motor and motor/encoder cable). The cables must not be extended and the cable length of 30 m must not be exceeded.

Controller CMXH-ST2

Technical data

Pin allocation for front side

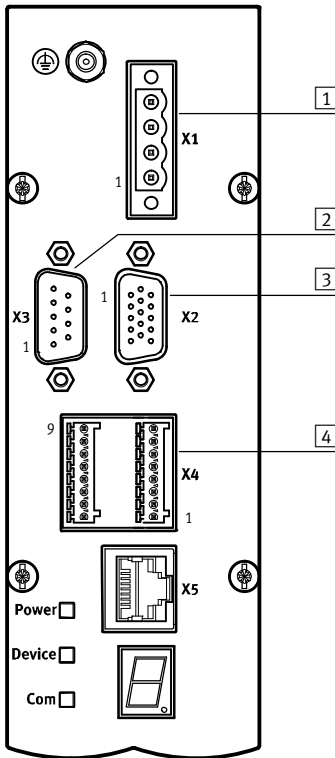

1 Power supply

Pin	Function
1	0 V (reference potential for load voltage)
2	+24 V or +48 V (load)
3	0 V (reference potential for logic voltage)
4	+24 V (logic)

2 CAN interface

Pin	Function
1	n.c.
2	CAN-L
3	0 V (GND)
4	n.c.
5	Screening
6	n.c.
7	CAN-H
8	n.c.
9	n.c.

3 I/O interface

Pin	Function		
1	RDYEN	Output	Ready for enable
2	DIN1	Input	Record selection 1
3	DIN2	Input	Record selection 2
4	DIN3	Input	Record selection 3
5	DIN4	Input	Record selection 4
6	DIN5	Input	Record selection 5
7	+24 V	Voltage	Logic voltage output
8	START	Input	Start record
9	ENABLE	Input	Enable drive and operation
10	RESET	Input	Acknowledge error
11	ENABLED	Output	Drive and operation are enabled
12	FAULT	Output	Fault present
13	ACK	Output	Acknowledgment for start signal
14	MC	Output	Motion complete
15	GND	Voltage	Reference potential

4 Switch-off functions

Pin	Function		
1	+24 V	Logic voltage output	
2	STO1	Safe torque off 1	
3	STO2	Safe torque off 2	
4	–	Reserved	
5	FAULT	Fault present	
6	DIAG1	Potential-free diagnostics contact 1	
7	DIAG2	Potential-free diagnostics contact 2	
8	GND	Reference potential	
9	–	Reserved	
10	–	Reserved	
11	–	Reserved	
12	TrOTF	Trigger On The Fly	
13	–	Reserved	
14	RB	Release brake	
15	ESTOP	External stop	
16	+24 V	Logic voltage output	

Controller CMXH-ST2

Technical data

Pin allocation for reverse side

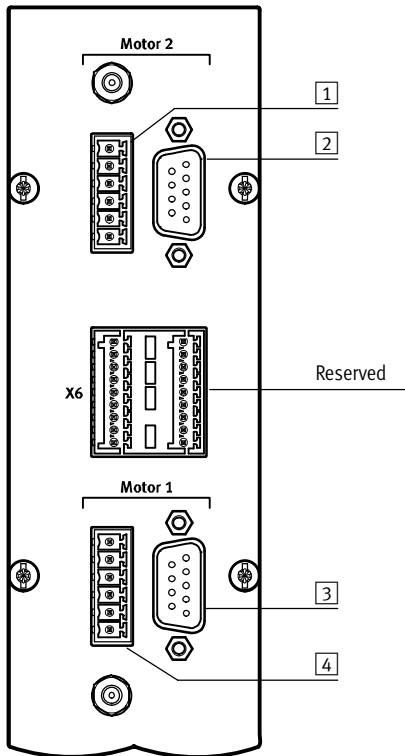

1 Motor 2		
Pin	Function	
1	A	Motor winding A
2	A/	Motor winding A
3	B	Motor winding B
4	B/	Motor winding B
5	BR+	Brake +24 V (is switched)
6	BR-	Brake 0 V (GND)

2 Encoder 2		
Pin	Function	
1	A	Encoder signal A+
2	B	Encoder signal B+
3	N	Encoder signal N+
4	GND	Reference potential
5	Vcc	Supply voltage (+5 V for encoder)
6	A/	Encoder signal A-
7	B/	Encoder signal B-
8	N/	Encoder signal N-
9	-	Reserved

3 Encoder 1		
Pin	Function	
1	A	Encoder signal A+
2	B	Encoder signal B+
3	N	Encoder signal N+
4	GND	Reference potential
5	Vcc	Supply voltage (+5 V for encoder)
6	A/	Encoder signal A-
7	B/	Encoder signal B-
8	N/	Encoder signal N-
9	-	Reserved

4 Motor 1		
Pin	Function	
1	A	Motor winding A
2	A/	Motor winding A
3	B	Motor winding B
4	B/	Motor winding B
5	BR+	Brake +24 V (is switched)
6	BR-	Brake 0 V (GND)

Controller CMXH-ST2

Technical data

Dimensions

Download CAD data → www.festo.com

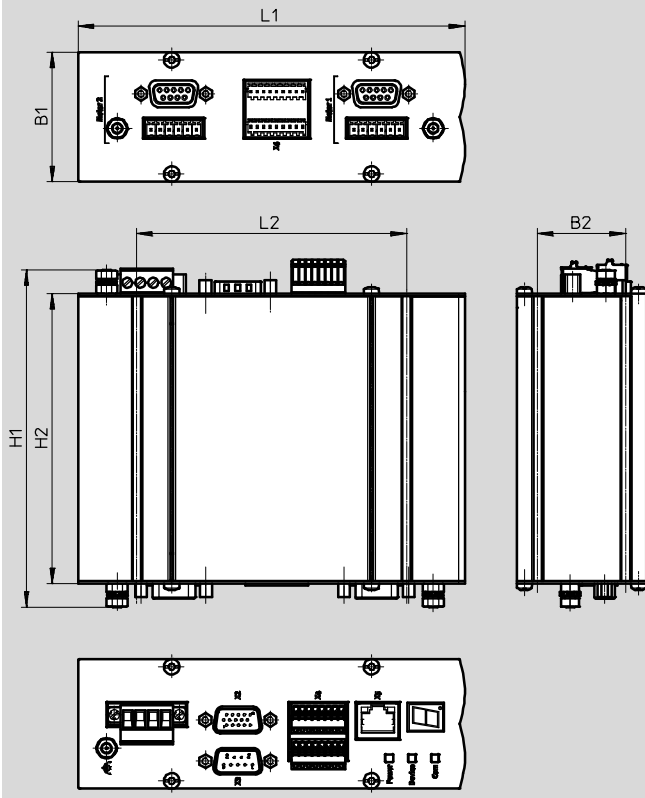

Type	B1	B2	H1	H2	L1	L2
CMXH-ST2	50	34	130	112	149	104

Ordering data

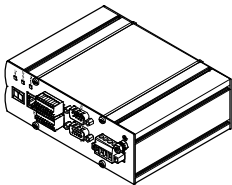
Controller	Description	Part No.	Type
	Switching input/output PNP	3605478	CMXH-ST2-C5-7-DIOP

Controller CMXH-ST2

Accessories



H-rail mounting CAFM

for H-rail to EN 50022

Materials:

Anodised aluminum

RoHS-compliant

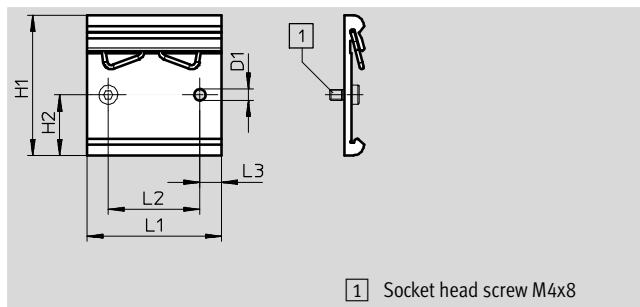

Dimensions and ordering data								
D1	H1	H2	L1	L2	L3	Weight [g]	Part No.	Type
4.2	52	22.5	50	34	8	29	4135048	CAFM-D3-H