

Hinge cylinders DFAW

FESTO



# Hinge cylinders DFAW

Key features



## At a glance

- Hinge cylinder for clamping components during the welding process
- Sintered bronze bushes as low-friction bearing material on rod clevis and swivel bearing
- Clamping unit:
  - With piston rod in retracted position (CE)
  - With piston rod in advanced position (CR)
- Integrated flow control
- Integrated, self-adjusting end-position cushioning (PPS)
- Rod wiper seal to protect against welding spatter
- Easy to mount thanks to swivel bearing on the bearing cap
- Asian automotive standard for car body production

## The technology in detail

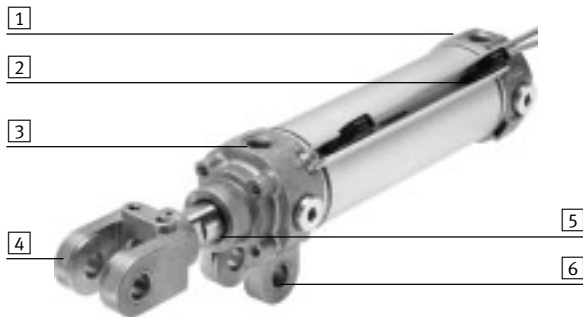

- 1 Adjustable, integrated flow control at both ends
- 2 Sensing options:
  - Via mounting bracket
  - Via sensor rail:
    - Sensor rail with T-slot, for proximity sensor:
      - SDBT-BSW
      - SMT-8
    - Sensor rail with hexagonal design
- 3 Pneumatic connection options on 3 sides
- 4 Choice of 4 rod clevis gaps
- 5 Metal wiper seal to protect against welding spatter
- 6 Swivel bearing on the cylinder

## Clamping unit with piston rod in retracted position (CE)



- In the depressurised state, the piston rod can be clamped in any desired position, preventing it from advancing
- The clamping unit is unlocked automatically while advancing. No separate control is required to do this
- The clamping unit can be unlocked manually using a screw under the "Remove" protective cap

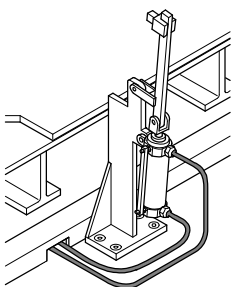

In the depressurised state, the clamping arm cannot fall onto the workpiece.

## Clamping unit with piston rod in advanced position (CR)



- In the depressurised state, the piston rod can be clamped in any desired position, preventing it from retracting
- The clamping unit is unlocked automatically while retracting. No separate control is required to do this
- The clamping unit can be unlocked manually using a screw under the "Remove" protective cap

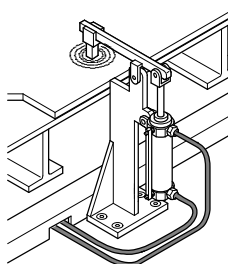

The clamped workpieces cannot slip, even in the depressurised state.

# Hinge cylinders DFAW

Key features

FESTO

Use as a clamping cylinder

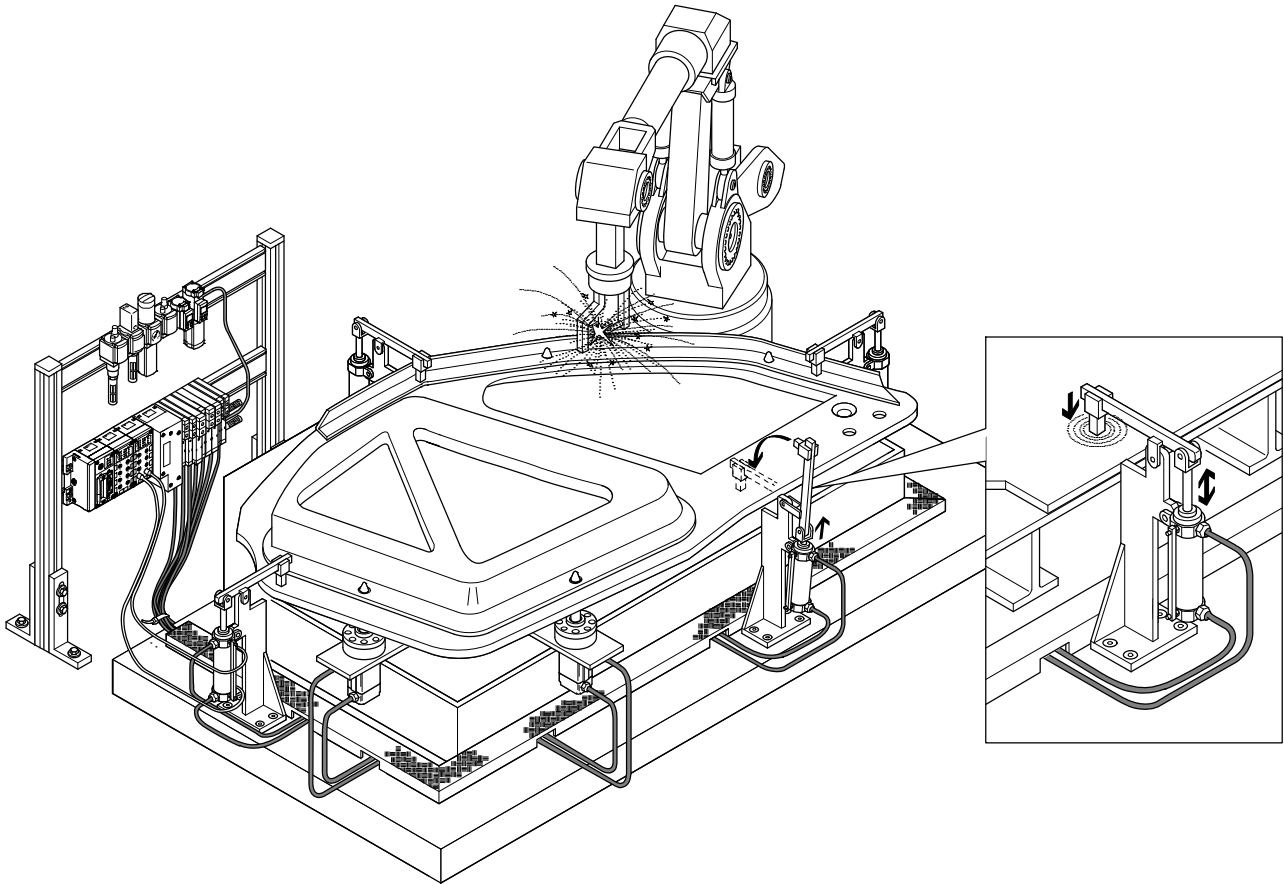

# Hinge cylinders DFAW

Type codes

## Hinge cylinders DFAW

		DFAW	-	50	-	50	-	CR	B5	-	PPS	A
<b>Type</b>												
DFAW	Hinge cylinder											
<b>Piston Ø [mm]</b>												
...	50, 63, 80											
<b>Stroke [mm]</b>												
...	50, 75, 100, 125, 150											
...	10 ... 200											
<b>Clamping unit attached</b>												
-	None											
CE	With piston rod in retracted position											
CR	With piston rod in advanced position											
<b>Rod clevis gap/swivel bearing [mm]</b>												
B4	16.5											
B5	18.5 (rod clevis), 16.5 (swivel bearing)											
B6	19.5											
B8	28											
<b>Cushioning</b>												
PPS	Pneumatic cushioning, self-adjusting at both ends											
<b>Position sensing</b>												
A	Via proximity sensor											

# Hinge cylinders DFAW

Type codes

## Accessory: Sensor rail DASP

DASP – F5 – 50 – 50 – A – SR – S7 – 2

Type	
DASP	Sensor rail

Allocation	
F5	Version for DFAW

Size 1)	
...	50, 80

Stroke [mm]	
...	50, 75, 100, 125, 150
...	10 ... 200

Mounting component design	
A	With T-slot
H	Hexagonal

Product type	
SR	Sensor rail

Proximity sensor, magneto-resistive	
–	None
S1	Welding field immune, N/O contact, 2-wire, 5.0 m
S2	Welding field immune, PNP, M12 plug, 3-wire, 0.3 m
S3	Welding field immune, NPN, M12 plug, 3-wire, 0.3 m
S4	Welding field immune, PNP, cable, 3-wire, 5.0 m
S5	Welding field immune, NPN, cable, 3-wire, 5.0 m
S6	PNP, M8 plug, 3-wire, 0.3 m
S7	PNP, cable, 3-wire, 2.5 m
S8	PNP, M12 plug, 3-wire, 0.3 m
S9	NPN, M8 plug, 3-wire, 0.3 m
S10	N/O contact, cable, 2-wire, 5.0 m, with ATEX certification

Number of proximity sensors	
–	None
1	One
2	Two

Mounting position of proximity sensor	
–	At both ends
F	Advanced end position
R	Retracted end position

1) Size 50 for DFAW-50/63  
Size 80 for DFAW-80

# Hinge cylinders DFAW

Peripherals overview

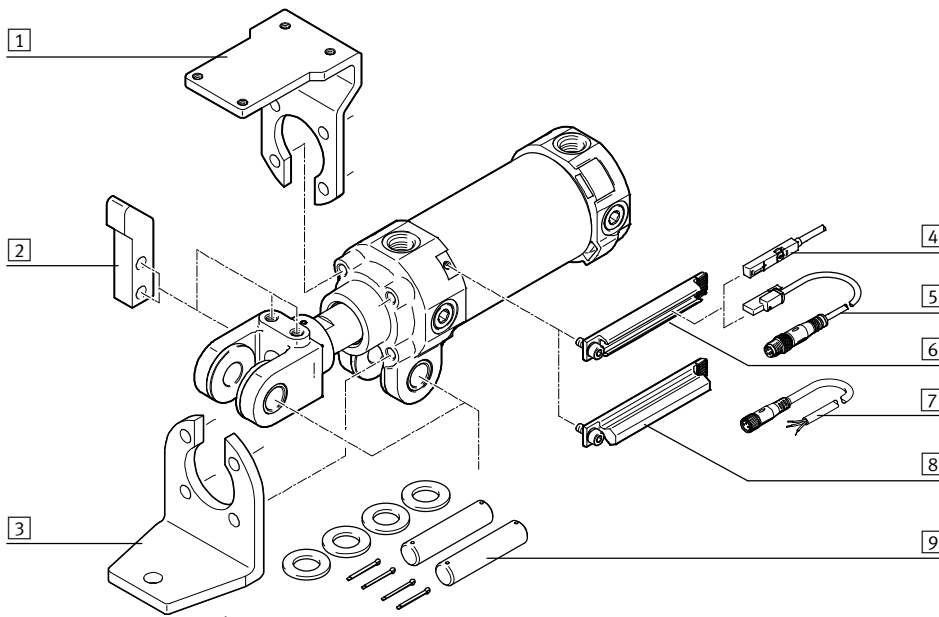

Included in the scope of delivery of the cylinder:

- Item 9

Accessories			
Type	Description	→ Page/Internet	
1	Mounting bracket TBH	For mounting external proximity sensors (e.g. roller lever switch)	20
2	Switch lever KTH	For sensing the piston rod position via external proximity sensors	20
3	Foot mounting HNH	For mounting the cylinder	20
4	Proximity sensor SMT-8 (DASP-...-S6 ... S10)	<ul style="list-style-type: none"> <li>• Proximity sensor with flat design for sensing the piston rod position</li> <li>• The proximity sensors are already mounted and adjusted when they and the sensor rail are ordered via the modular product system (→ page 18)</li> </ul>	21
5	Proximity sensor SDBT-BSW (DASP-...-S1 ... S5)	<ul style="list-style-type: none"> <li>• Welding field immune proximity sensor for sensing the piston rod position</li> <li>• The proximity sensors are already mounted and adjusted when they and the sensor rail are ordered via the modular product system (→ page 18)</li> </ul>	21
6	Sensor rail DASP-...-A	With T-slot, for mounting the proximity sensor SDBT-BSW or SMT-8	18
7	Connecting cable NEBU	For proximity sensor with plug	21
8	Sensor rail DASP-...-H	Hexagonal design	19
9	Mounting kit DAMD	<ul style="list-style-type: none"> <li>• For mounting the drive and attachments on the rod clevis</li> <li>• The scope of delivery of the drive includes 2 bolts, 2 retaining pins and 4 washers</li> </ul>	21

# Hinge cylinders DFAW

Technical data

FESTO

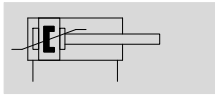

⊘ - Diameter  
50 ... 80 mm

┆ - Stroke length  
10 ... 200 mm

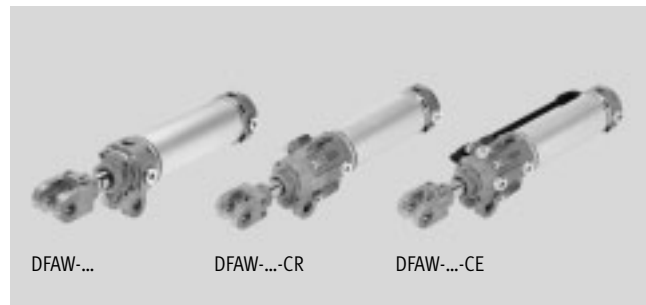

General technical data			
Piston Ø		50	63
Pneumatic connection		G1/4	G3/8
Piston rod thread		M16x1.5	M20x1.5
Piston rod end		Male thread with rod clevis	
Stroke	Standard	[mm]	50, 75, 100, 125, 150
	Variable	[mm]	10 ... 200
Rod clevis gap		[mm]	16.5; 18.5; 19.5
Design			Piston rod with rod clevis
			Swivel mounting on bearing cap
			Cylinder barrel
			Piston
Mode of operation			Double-acting
			Pushing and pulling
Type of mounting			Via swivel mounting on bearing cap
			Via accessories
Speed control			Integrated flow control at both ends
Mounting position			Any
Position sensing			Via proximity sensor
Cushioning			Pneumatic cushioning, self-adjusting at both ends
Cushioning length		[mm]	24
			30

Operating and environmental conditions			
Piston Ø		50	63
Operating medium		Compressed air to ISO 8573-1:2010 [7:4:4]	
Note on operating/pilot medium		Operation with lubricated medium possible (in which case lubricated operation will always be required)	
Operating pressure	DFAW-...	[bar]	1 ... 10
	DFAW-...-CE/-CR	[bar]	2 ... 10
Ambient temperature		[°C]	-10 ... +60

Weight [g]			
Piston Ø		50	63
DFAW-...			
Basic weight with 0 mm stroke		1103	1339
Additional weight per 10 mm stroke		37	39
Moving mass with 0 mm stroke		539	600
Additional weight per 10 mm stroke		25	25
DFAW-...-CE/-CR			
Basic weight with 0 mm stroke		1652	1969
Additional weight per 10 mm stroke		37	39
Moving mass with 0 mm stroke		653	717
Additional weight per 10 mm stroke		25	25

# Hinge cylinders DFAW

Technical data

FESTO

Forces [N] and impact energy [J]			
Piston Ø	50	63	80
Theoretical force at 6 bar, advancing	1178	1870	3016
Theoretical force at 6 bar, retracting	990	1682	2721
Impact energy in the end positions	0.24	0.76	0.84

## Materials

Sectional view

DFAW-...

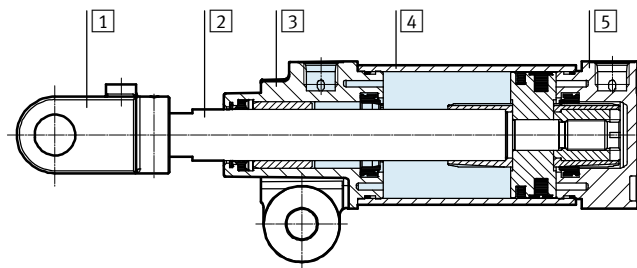

DFAW-...-CE

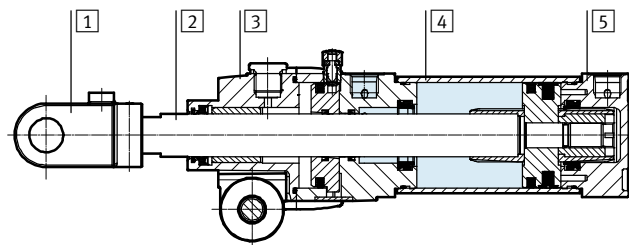

DFAW-...-CR

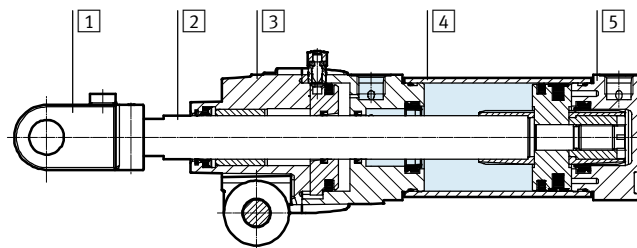

Piston Ø	50	63	80
1 Rod clevis	Anodised die-cast aluminium		Cast steel
2 Piston rod	Hard-chromium plated tempered steel		
3 Bearing cap with mounting	Anodised die-cast aluminium		
4 Cylinder barrel	Anodised wrought aluminium alloy		
5 End cap	Anodised die-cast aluminium		
- Inside of rod clevis, swivel bearing	Sintered bronze		
Wiper seal	Bronze		
Seals	Nitrile rubber		
Note on materials	RoHS-compliant		

## Technical data DFAW-...-CE/-CR with clamping unit

- The specified holding force refers to a static load
- If this value is exceeded, slippage may occur
- To avoid accidents or damage due to sudden movement of the piston rod, the clamping unit may only be released if the forces at the piston have reached equilibrium

Piston Ø	50	63
Static holding force [N]	980	1560
Max. axial backlash with end position locked and		
holding force of 10 N [mm]	0.1	
max. holding force <sup>1)</sup> [mm]	< 1	

1) When new.



# Hinge cylinders DFAW

Technical data

FESTO

## Dimensions

Download CAD data → [www.festo.com](http://www.festo.com)

DFAW-...

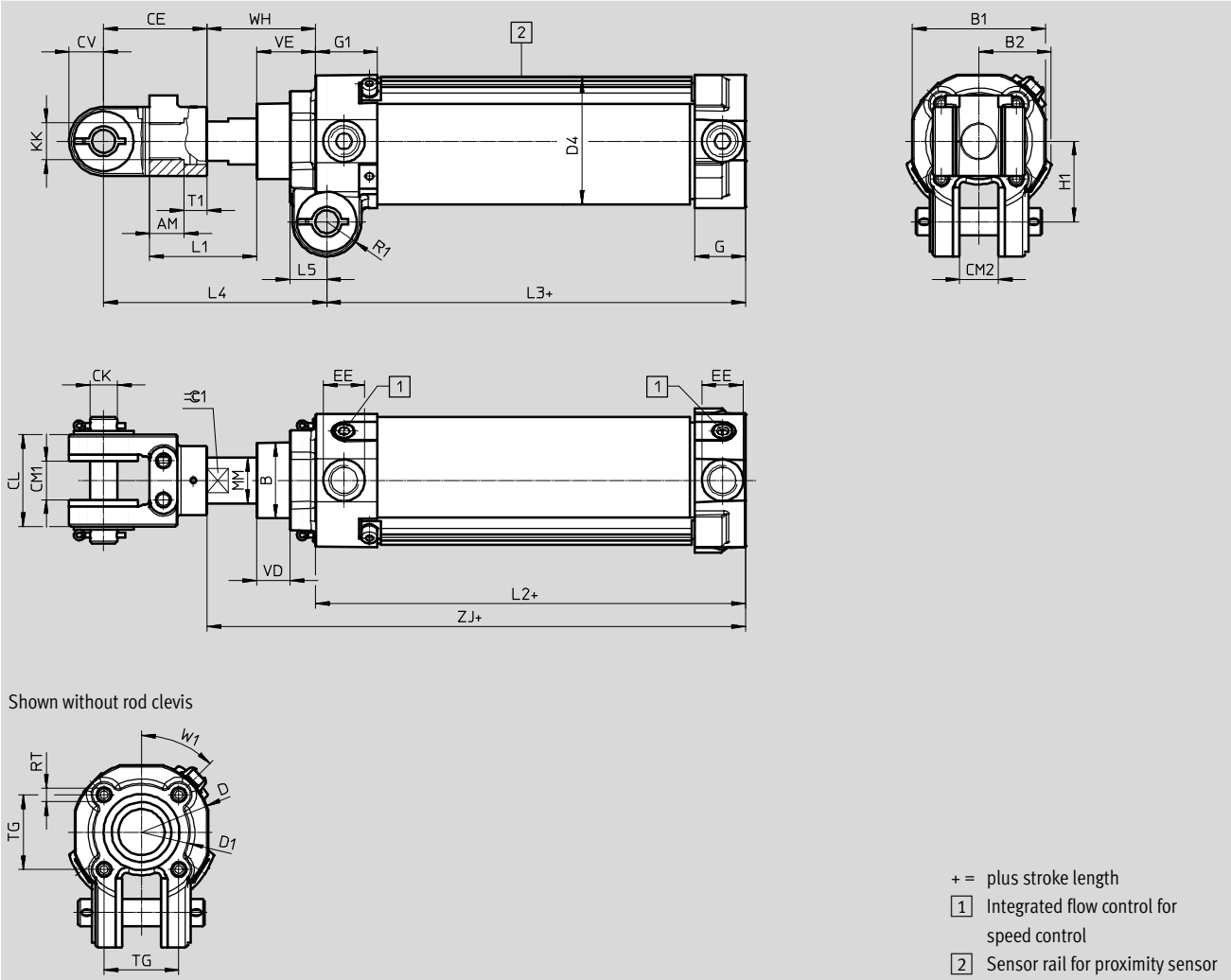

Shown without rod clevis

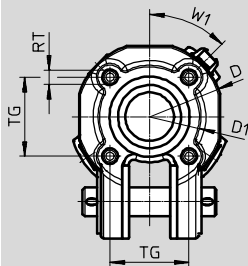

- + = plus stroke length
- 1 Integrated flow control for speed control
- 2 Sensor rail for proximity sensor

∅ [mm]	AM	B ∅	B1	B2	CE	CK ∅	CL	CM1				CM2				CV
								DFAW-...				DFAW-...				
								-B4	-B5	-B6	-B8	-B4	-B5	-B6	-B8	
50	15	33	58	32	45	12	40	16.5	18.5	19.5	-	16.5	16.5	19.5	-	15
63			71	43				-	-	-	28	-	-	-	28	19
80	19	46	89	52	58	18	60	-	-	-	28	-	-	-	28	19

∅ [mm]	D ∅	D1 ∅	D4 ∅	EE	G	G1	H1	KK	L1	L2	L3	L4
50	61	42	55	G1/4	22	27	35	M16x1.5	46.5	87	82	97
63	75		69									
80	93	60	87	G3/8	34	31.5	50	M20x1.5	43	131.5	128	110

∅ [mm]	L5	MM ∅	R1	RT	T1	TG	VD	VE	W1	WH	ZJ	≈C 1
50	16	20	15	M6	10	32.5	14.5	25.5	45°	47	134	17
63												
80	20	25	20	M6	11	32.5	19	35.5	45°	48.5	180	19

# Hinge cylinders DFAW

Technical data

FESTO

## Dimensions

Download CAD data → [www.festo.com](http://www.festo.com)

DFAW-...-CE

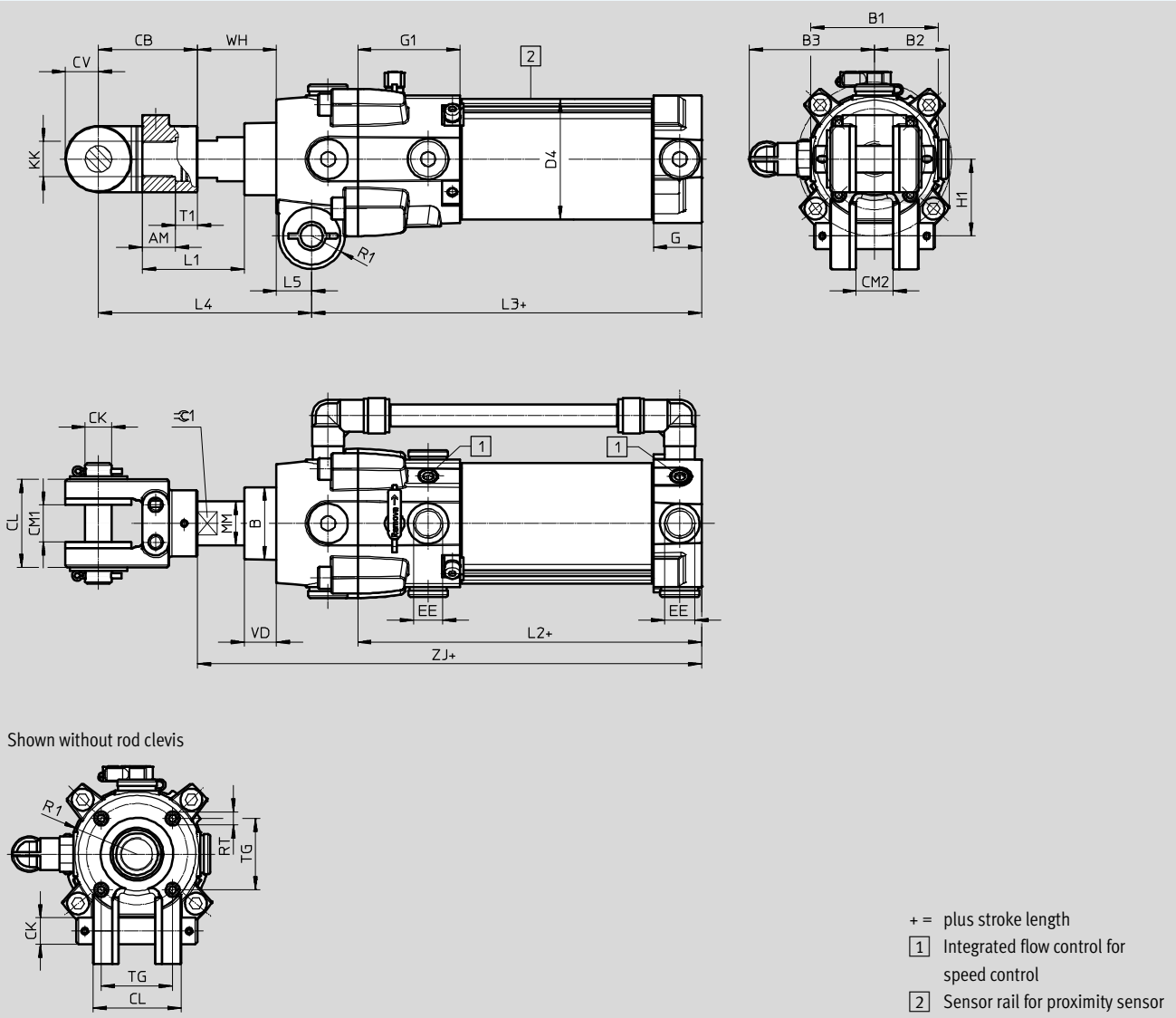

∅	AM	B ∅	B1	B2	B3	CB	CK ∅	CL	CM1			CM2		
									DFAW-... -B4	-B5	-B6	DFAW-... -B4	-B5	-B6
50	15	33	58	34	57	45	12	40	16.5	18.5	19.5	16.5	16.5	19.5
63			71	40.5	63.5				16.5	16.5	19.5			

∅	CV	D ∅	D4 ∅	EE	G	G1	H1	KK	L1	L2	L3	L4
50	15	59	55	G1/4	22	46.5	35	M16x1.5	46.5	143.5	127.5	97
63			69							146.5	130.5	

∅	L5	MM ∅	R1	RT	T1	TG	VD	W1	WH	ZJ	≈C 1
50	16	20	15	M6	10	32.5	14.5	45°	36	179.5	17
63										182.5	

# Hinge cylinders DFAW

Technical data

## Dimensions

DFAW-...-CR

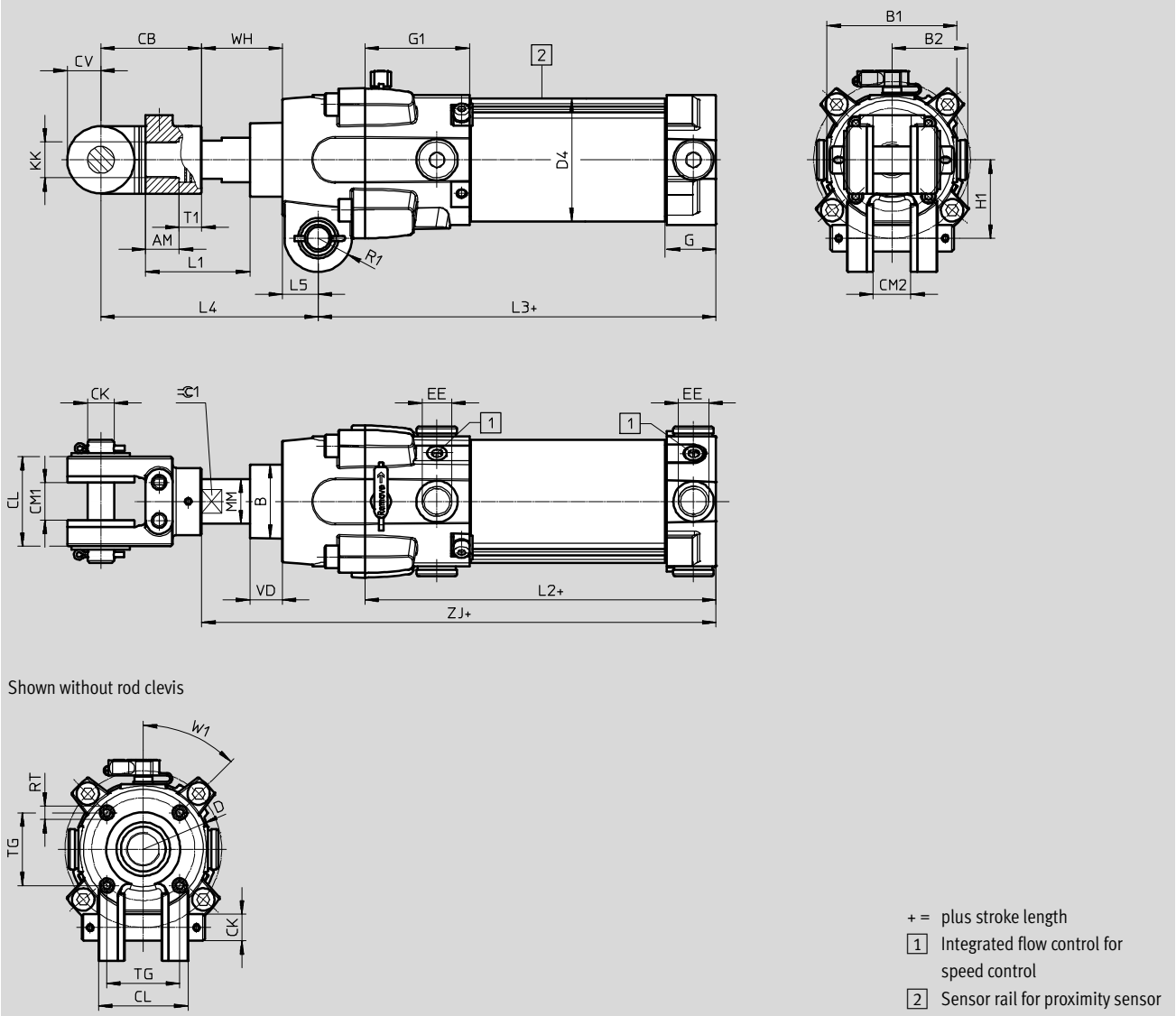

Shown without rod clevis

∅ [mm]	AM	B ∅	B1	B2	CB	CK ∅	CL	CM1			CM2		
								DFAW-... -B4	-B5	-B6	DFAW-... -B4	-B5	-B6
50	15	33	58	34	45	12	40	16.5	18.5	19.5	16.5	16.5	19.5
63			71	40.5									

∅ [mm]	CV	D ∅	D4 ∅	EE	G	G1	H1	KK	L1	L2	L3	L4
50	15	59	55	G1/4	22	46.5	±0.1	M16x1.5	46.5	143.5	127.5	97
63			69							146.5	130.5	

∅ [mm]	L5	MM ∅	R1	RT	T1	TG	VD	W1	WH	ZJ	∠C1
50	16	20	15	M6	10	32.5	14.5	45°	36	179.5	17
63										182.5	

# Hinge cylinders DFAW

Technical data

FESTO

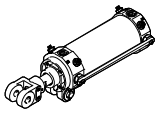
Ordering data – Hinge cylinder							
	Piston Ø [mm]	Stroke [mm]	Rod clevis gap/swivel bearing		Rod clevis gap/swivel bearing		
			Part No.	Type	Part No.	Type	
	50		16.5 mm		18.5 mm (swivel bearing 16.5 mm)		
		50	<b>2689548</b>	<b>DFAW-50-50-B4-PPSA</b>	<b>2689550</b>	<b>DFAW-50-50-B5-PPSA</b>	
		75	<b>2689552</b>	<b>DFAW-50-75-B4-PPSA</b>	<b>2689553</b>	<b>DFAW-50-75-B5-PPSA</b>	
		100	<b>2689555</b>	<b>DFAW-50-100-B4-PPSA</b>	<b>2689556</b>	<b>DFAW-50-100-B5-PPSA</b>	
		125	<b>2689559</b>	<b>DFAW-50-125-B4-PPSA</b>	<b>2689560</b>	<b>DFAW-50-125-B5-PPSA</b>	
		150	<b>2689562</b>	<b>DFAW-50-150-B4-PPSA</b>	<b>2689563</b>	<b>DFAW-50-150-B5-PPSA</b>	
			19.5 mm				
		50	<b>2689551</b>	<b>DFAW-50-50-B6-PPSA</b>			
		75	<b>2689554</b>	<b>DFAW-50-75-B6-PPSA</b>			
		100	<b>2689557</b>	<b>DFAW-50-100-B6-PPSA</b>			
		125	<b>2689561</b>	<b>DFAW-50-125-B6-PPSA</b>			
		150	<b>2689564</b>	<b>DFAW-50-150-B6-PPSA</b>			
		63			16.5 mm		18.5 mm (swivel bearing 16.5 mm)
	50		<b>2690075</b>	<b>DFAW-63-50-B4-PPSA</b>	<b>2690096</b>	<b>DFAW-63-50-B5-PPSA</b>	
	75		<b>2690098</b>	<b>DFAW-63-75-B4-PPSA</b>	<b>2690099</b>	<b>DFAW-63-75-B5-PPSA</b>	
	100		<b>2690101</b>	<b>DFAW-63-100-B4-PPSA</b>	<b>2690102</b>	<b>DFAW-63-100-B5-PPSA</b>	
	125		<b>2690104</b>	<b>DFAW-63-125-B4-PPSA</b>	<b>2690105</b>	<b>DFAW-63-125-B5-PPSA</b>	
	150		<b>2690107</b>	<b>DFAW-63-150-B4-PPSA</b>	<b>2690108</b>	<b>DFAW-63-150-B5-PPSA</b>	
			19.5 mm				
50	<b>2690097</b>		<b>DFAW-63-50-B6-PPSA</b>				
75	<b>2690100</b>		<b>DFAW-63-75-B6-PPSA</b>				
100	<b>2690103</b>		<b>DFAW-63-100-B6-PPSA</b>				
125	<b>2690106</b>		<b>DFAW-63-125-B6-PPSA</b>				
150	<b>2690109</b>		<b>DFAW-63-150-B6-PPSA</b>				
80				28 mm			
	50	<b>2691530</b>	<b>DFAW-80-50-B8-PPSA</b>				
	75	<b>2691531</b>	<b>DFAW-80-75-B8-PPSA</b>				
	100	<b>2691532</b>	<b>DFAW-80-100-B8-PPSA</b>				
	125	<b>2691533</b>	<b>DFAW-80-125-B8-PPSA</b>				
	150	<b>2691534</b>	<b>DFAW-80-150-B8-PPSA</b>				

# Hinge cylinders DFAW

Technical data

FESTO

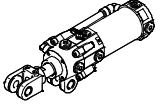
Ordering data – Hinge cylinder with clamping unit with piston rod in retracted position								
	Piston Ø [mm]	Stroke [mm]	Rod clevis gap/swivel bearing		Rod clevis gap/swivel bearing			
			Part No.	Type	Part No.	Type		
	50		16.5 mm		18.5 mm (swivel bearing 16.5 mm)			
		50	<b>2876449</b>	<b>DFAW-50-50-CEB4-PPSA</b>	<b>2876454</b>	<b>DFAW-50-50-CEB5-PPSA</b>		
		75	<b>2876450</b>	<b>DFAW-50-75-CEB4-PPSA</b>	<b>2876455</b>	<b>DFAW-50-75-CEB5-PPSA</b>		
		100	<b>2876451</b>	<b>DFAW-50-100-CEB4-PPSA</b>	<b>2876456</b>	<b>DFAW-50-100-CEB5-PPSA</b>		
		125	<b>2876452</b>	<b>DFAW-50-125-CEB4-PPSA</b>	<b>2876457</b>	<b>DFAW-50-125-CEB5-PPSA</b>		
		150	<b>2876453</b>	<b>DFAW-50-150-CEB4-PPSA</b>	<b>2876458</b>	<b>DFAW-50-150-CEB5-PPSA</b>		
			19.5 mm					
		50	<b>2876459</b>	<b>DFAW-50-50-CEB6-PPSA</b>				
		75	<b>2876460</b>	<b>DFAW-50-75-CEB6-PPSA</b>				
		100	<b>2876461</b>	<b>DFAW-50-100-CEB6-PPSA</b>				
		125	<b>2876462</b>	<b>DFAW-50-125-CEB6-PPSA</b>				
		150	<b>2876463</b>	<b>DFAW-50-150-CEB6-PPSA</b>				
		63			16.5 mm		18.5 mm (swivel bearing 16.5 mm)	
			50	<b>2885073</b>	<b>DFAW-63-50-CEB4-PPSA</b>	<b>2885079</b>	<b>DFAW-63-50-CEB5-PPSA</b>	
	75		<b>2885075</b>	<b>DFAW-63-75-CEB4-PPSA</b>	<b>2885080</b>	<b>DFAW-63-75-CEB5-PPSA</b>		
	100		<b>2885076</b>	<b>DFAW-63-100-CEB4-PPSA</b>	<b>2885081</b>	<b>DFAW-63-100-CEB5-PPSA</b>		
	125		<b>2885077</b>	<b>DFAW-63-125-CEB4-PPSA</b>	<b>2885082</b>	<b>DFAW-63-125-CEB5-PPSA</b>		
	150		<b>2885078</b>	<b>DFAW-63-150-CEB4-PPSA</b>	<b>2885083</b>	<b>DFAW-63-150-CEB5-PPSA</b>		
			19.5 mm					
50	<b>2885084</b>		<b>DFAW-63-50-CEB6-PPSA</b>					
75	<b>2885085</b>		<b>DFAW-63-75-CEB6-PPSA</b>					
100	<b>2885086</b>		<b>DFAW-63-100-CEB6-PPSA</b>					
125	<b>2885087</b>		<b>DFAW-63-125-CEB6-PPSA</b>					
150	<b>2885088</b>		<b>DFAW-63-150-CEB6-PPSA</b>					

# Hinge cylinders DFAW

Technical data

FESTO

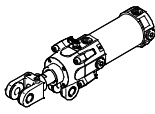
Ordering data – Hinge cylinder with clamping unit with piston rod in advanced position								
	Piston Ø [mm]	Stroke [mm]	Rod clevis gap/swivel bearing		Rod clevis gap/swivel bearing			
			Part No.	Type	Part No.	Type		
	50		16.5 mm		18.5 mm (swivel bearing 16.5 mm)			
		50	2876434	DFAW-50-50-CRB4-PPSA	2876439	DFAW-50-50-CRB5-PPSA		
		75	2876435	DFAW-50-75-CRB4-PPSA	2876440	DFAW-50-75-CRB5-PPSA		
		100	2876436	DFAW-50-100-CRB4-PPSA	2876441	DFAW-50-100-CRB5-PPSA		
		125	2876437	DFAW-50-125-CRB4-PPSA	2876442	DFAW-50-125-CRB5-PPSA		
		150	2876438	DFAW-50-150-CRB4-PPSA	2876443	DFAW-50-150-CRB5-PPSA		
			19.5 mm					
		50	2876444	DFAW-50-50-CRB6-PPSA				
		75	2876445	DFAW-50-75-CRB6-PPSA				
		100	2876446	DFAW-50-100-CRB6-PPSA				
		125	2876447	DFAW-50-125-CRB6-PPSA				
		150	2876448	DFAW-50-150-CRB6-PPSA				
		63			16.5 mm		18.5 mm (swivel bearing 16.5 mm)	
			50	2885033	DFAW-63-50-CRB4-PPSA	2885045	DFAW-63-50-CRB5-PPSA	
	75		2885038	DFAW-63-75-CRB4-PPSA	2885046	DFAW-63-75-CRB5-PPSA		
	100		2885039	DFAW-63-100-CRB4-PPSA	2885047	DFAW-63-100-CRB5-PPSA		
	125		2885040	DFAW-63-125-CRB4-PPSA	2885048	DFAW-63-125-CRB5-PPSA		
	150		2885041	DFAW-63-150-CRB4-PPSA	2885049	DFAW-63-150-CRB5-PPSA		
			19.5 mm					
	50		2885062	DFAW-63-50-CRB6-PPSA				
75	2885063		DFAW-63-75-CRB6-PPSA					
100	2885064		DFAW-63-100-CRB6-PPSA					
125	2885065		DFAW-63-125-CRB6-PPSA					
150	2885066		DFAW-63-150-CRB6-PPSA					

# Hinge cylinders DFAW

Technical data

FESTO

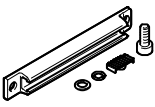
Ordering data – Sensor rail accessories									
Design	For $\varnothing$ [mm]	Stroke [mm]	Proximity sensor, welding field immune		For end position		Part No.	Type	
			N/O contact, 2-wire	PNP, 3-wire	Advanced	Retracted			
With T-slot									
	50, 63	50	-	-	-	-	8031580	DASP-F5-50-50-A-SR	
			■	-	■	-	8031590	DASP-F5-50-50-A-SR-S1-1F	
			■	-	-	■	8031595	DASP-F5-50-50-A-SR-S1-1R	
			■	-	■	■	8031585	DASP-F5-50-50-A-SR-S1-2	
			-	■	■	-	8031605	DASP-F5-50-50-A-SR-S4-1F	
			-	■	-	■	8031610	DASP-F5-50-50-A-SR-S4-1R	
		-	■	■	■	8031600	DASP-F5-50-50-A-SR-S4-2		
		-	-	-	-	-	-	8031581	DASP-F5-50-75-A-SR
		■	-	■	-	8031591	DASP-F5-50-75-A-SR-S1-1F		
		■	-	-	-	8031596	DASP-F5-50-75-A-SR-S1-1R		
		■	-	■	■	8031586	DASP-F5-50-75-A-SR-S1-2		
		-	■	■	-	8031606	DASP-F5-50-75-A-SR-S4-1F		
		-	■	-	■	8031611	DASP-F5-50-75-A-SR-S4-1R		
		-	■	■	■	8031601	DASP-F5-50-75-A-SR-S4-2		
		-	-	-	-	-	-	8031582	DASP-F5-50-100-A-SR
		■	-	■	-	8031592	DASP-F5-50-100-A-SR-S1-1F		
		■	-	-	-	8031597	DASP-F5-50-100-A-SR-S1-1R		
		■	-	■	■	8031587	DASP-F5-50-100-A-SR-S1-2		
		-	■	■	-	8031607	DASP-F5-50-100-A-SR-S4-1F		
		-	■	-	■	8031612	DASP-F5-50-100-A-SR-S4-1R		
		-	■	■	■	8031602	DASP-F5-50-100-A-SR-S4-2		
		-	-	-	-	-	-	8031583	DASP-F5-50-125-A-SR
		■	-	■	-	8031593	DASP-F5-50-125-A-SR-S1-1F		
		■	-	-	-	8031598	DASP-F5-50-125-A-SR-S1-1R		
		■	-	■	■	8031588	DASP-F5-50-125-A-SR-S1-2		
		-	■	■	-	8031608	DASP-F5-50-125-A-SR-S4-1F		
		-	■	-	■	8031613	DASP-F5-50-125-A-SR-S4-1R		
		-	■	■	■	8031603	DASP-F5-50-125-A-SR-S4-2		
		-	-	-	-	-	-	8031584	DASP-F5-50-150-A-SR
		■	-	■	-	8031594	DASP-F5-50-150-A-SR-S1-1F		
		■	-	-	-	8031599	DASP-F5-50-150-A-SR-S1-1R		
		■	-	■	■	8031589	DASP-F5-50-150-A-SR-S1-2		
		-	■	■	-	8031609	DASP-F5-50-150-A-SR-S4-1F		
		-	■	-	■	8031614	DASP-F5-50-150-A-SR-S4-1R		
		-	■	■	■	8031604	DASP-F5-50-150-A-SR-S4-2		

# Hinge cylinders DFAW

Technical data

FESTO

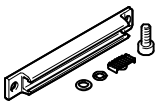
Ordering data – Sensor rail accessories									
Design	For Ø [mm]	Stroke [mm]	Proximity sensor, welding field immune		For end position		Part No.	Type	
			N/O contact, 2-wire	PNP, 3-wire	Advanced	Retracted			
With T-slot									
	80	50	-	-	-	-	8031615	DASP-F5-80-50-A-SR	
			■	-	■	-	8031625	DASP-F5-80-50-A-SR-S1-1F	
			■	-	-	■	8031630	DASP-F5-80-50-A-SR-S1-1R	
			■	-	■	■	8031620	DASP-F5-80-50-A-SR-S1-2	
			-	■	■	-	8031640	DASP-F5-80-50-A-SR-S4-1F	
			-	■	-	■	8031645	DASP-F5-80-50-A-SR-S4-1R	
		-	■	■	■	8031635	DASP-F5-80-50-A-SR-S4-2		
		-	75	-	-	-	-	8031616	DASP-F5-80-75-A-SR
		■		-	■	-	8031626	DASP-F5-80-75-A-SR-S1-1F	
		■		-	-	■	8031631	DASP-F5-80-75-A-SR-S1-1R	
		■		-	■	■	8031621	DASP-F5-80-75-A-SR-S1-2	
		-		■	■	-	8031641	DASP-F5-80-75-A-SR-S4-1F	
		-		■	-	■	8031646	DASP-F5-80-75-A-SR-S4-1R	
		-	■	■	■	8031636	DASP-F5-80-75-A-SR-S4-2		
		-	100	-	-	-	-	8031617	DASP-F5-80-100-A-SR
		■		-	■	-	8031627	DASP-F5-80-100-A-SR-S1-1F	
		■		-	-	■	8031632	DASP-F5-80-100-A-SR-S1-1R	
		■		-	■	■	8031622	DASP-F5-80-100-A-SR-S1-2	
		-		■	■	-	8031642	DASP-F5-80-100-A-SR-S4-1F	
		-		■	-	■	8031647	DASP-F5-80-100-A-SR-S4-1R	
		-	■	■	■	8031637	DASP-F5-80-100-A-SR-S4-2		
		-	125	-	-	-	-	8031618	DASP-F5-80-125-A-SR
		■		-	■	-	8031628	DASP-F5-80-125-A-SR-S1-1F	
		■		-	-	■	8031633	DASP-F5-80-125-A-SR-S1-1R	
	■	-		■	■	8031623	DASP-F5-80-125-A-SR-S1-2		
	-	■		■	-	8031643	DASP-F5-80-125-A-SR-S4-1F		
	-	■		-	■	8031648	DASP-F5-80-125-A-SR-S4-1R		
	-	■	■	■	8031638	DASP-F5-80-125-A-SR-S4-2			
	-	150	-	-	-	-	8031619	DASP-F5-80-150-A-SR	
	■		-	■	-	8031629	DASP-F5-80-150-A-SR-S1-1F		
	■		-	-	■	8031634	DASP-F5-80-150-A-SR-S1-1R		
	■		-	■	■	8031624	DASP-F5-80-150-A-SR-S1-2		
	-		■	■	-	8031644	DASP-F5-80-150-A-SR-S4-1F		
-	■		-	■	8031649	DASP-F5-80-150-A-SR-S4-1R			
-	■	■	■	8031639	DASP-F5-80-150-A-SR-S4-2				

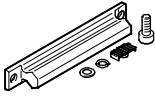
Ordering data – Sensor rail accessories				
Design	For Ø [mm]	Stroke [mm]	Part No.	Type
Hexagonal				
	50, 63	50	8031838	DASP-F5-50-50-H-SR
		75	8031839	DASP-F5-50-75-H-SR
		100	8031840	DASP-F5-50-100-H-SR
		125	8031841	DASP-F5-50-125-H-SR
		150	8031842	DASP-F5-50-150-H-SR
	80	50	8031844	DASP-F5-80-50-H-SR
		75	8031845	DASP-F5-80-75-H-SR
		100	8031846	DASP-F5-80-100-H-SR
		125	8031847	DASP-F5-80-125-H-SR
		150	8031848	DASP-F5-80-150-H-SR



# Hinge cylinders DFAW

Ordering data – Modular product system



Ordering table – Hinge cylinder DFAW

Size	50	63	80	Conditions	Code	Enter code
[M] Module no.	<b>2676213</b>	<b>2682302</b>	<b>2682335</b>			
Series	Hinge cylinder				<b>DFAW</b>	DFAW
Piston diameter [mm]	50	63	80		-...	
Stroke [mm]	50, 75, 100, 125, 150 10 ... 200				-...	
Clamping unit, mounted	None					
	With piston rod in retracted position			-	<b>-CE</b>	
	With piston rod in advanced position			-	<b>-CR</b>	
Rod clevis gap [mm]	16.5			-	<b>-B4</b>	
	18.5/16.5			-	<b>-B5</b>	
	19.5			-	<b>-B6</b>	
	-			28	<b>-B8</b>	
Cushioning	Pneumatic cushioning, self-adjusting at both ends				<b>-PPS</b>	-PPS
Position sensing	Via proximity sensor				<b>A</b>	A

Transfer order code

# Hinge cylinders DFAW

Accessories



## Ordering table – Sensor rail with T-slot

Size	50 For Ø 50/63	80 For Ø 80	Conditions	Code	Enter code
<b>M</b> Module no.	<b>2749270</b>	<b>2785658</b>			
Series	Sensor rail			<b>DASP</b>	DASP
Allocation	Version for DFAW			<b>-F5</b>	-F5
Size [mm]	50	80		-...	
Stroke [mm]	50, 75, 100, 125, 150 10 ... 200			-...	
Mounting component design	With T-slot			<b>-A</b>	-A
Product type	Sensor rail			<b>-SR</b>	-SR
<b>O</b> Proximity sensor, magneto-resistive	None				
	Welding field immune, N/O contact, 2-wire, 5.0 m			<b>-S1</b>	
	Welding field immune, PNP, M12 plug, 3-wire, 0.3 m			<b>-S2</b>	
	Welding field immune, NPN, M12 plug, 3-wire, 0.3 m			<b>-S3</b>	
	Welding field immune, PNP, cable, 3-wire, 5.0 m			<b>-S4</b>	
	Welding field immune, NPN, cable, 3-wire, 5.0 m			<b>-S5</b>	
	PNP, M8 plug, 3-wire, 0.3 m			<b>-S6</b>	
	PNP, cable, 3-wire, 2.5 m			<b>-S7</b>	
	PNP, M12 plug, 3-wire, 0.3 m			<b>-S8</b>	
	NPN, M8 plug, 3-wire, 0.3 m			<b>-S9</b>	
	EX2, N/O contact, 2-wire, 5.0 m			<b>-S10</b>	
Number of proximity sensors	None				
	One		<input type="checkbox"/>	<b>-1</b>	
	Two		<input type="checkbox"/>	<b>-2</b>	
Mounting position of proximity sensor	At both ends				
	Advanced end position		<input type="checkbox"/>	<b>F</b>	
	Retracted end position		<input type="checkbox"/>	<b>R</b>	

1, 2, F, R Only with S1 ... S10

### Transfer order code

**DASP** -  **F5** -  -  -  **A** -  **SR** -  -  -

# Hinge cylinders DFAW

Accessories



Ordering table – Sensor rail, hexagonal design

Size	50 For DFAW-50/-63	80 For DFAW-80	Conditions	Code	Enter code
<b>[M]</b> Module no.	<b>2747377</b>	<b>2785652</b>			
Series	Sensor rail			<b>DASP</b>	DASP
Allocation	Version for DFAW			<b>-F5</b>	-F5
Size [mm]	50	80		-...	
Stroke [mm]	50, 75, 100, 125, 150 10 ... 200			-...	
Mounting component design	Hexagonal			<b>-H</b>	-H
Product type	Sensor rail			<b>-SR</b>	-SR

Transfer order code

- 
 - 
 - 
 - 
 -

# Hinge cylinders DFAW

Accessories



## Foot mounting HNH

Materials:  
Steel

Scope of delivery:  
4 screws

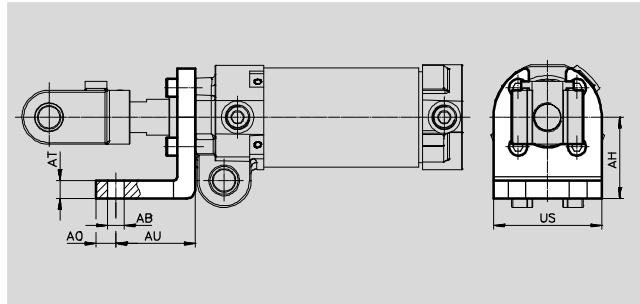

Dimensions and ordering data										
For $\varnothing$	AB $\varnothing$	AH	AO	AT	AU	US	Weight [g]	Part No.	Type	
50, 63, 80	9	45	11	10	44	60	241	<b>549603</b>	<b>HNH-50/63/80</b>	

## Mounting bracket TBH

Materials:  
Steel

Scope of delivery:  
4 screws, short  
4 screws, long

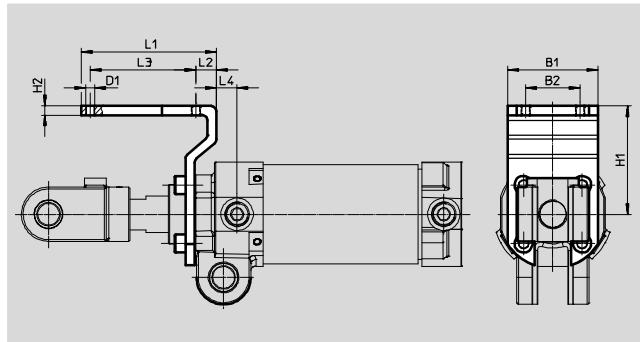

Dimensions and ordering data												
For $\varnothing$	B1	B2	D1	H1	H2	L1	L2	L3	L4	Weight [g]	Part No.	Type
50, 63	50	30.2	M5	60	5	75	11.3	58.7	11.5	282	<b>549605</b>	<b>TBH-50/63/80</b>
80									37			

## Switch lever KTH

Materials:  
Steel

Scope of delivery:  
2 screws

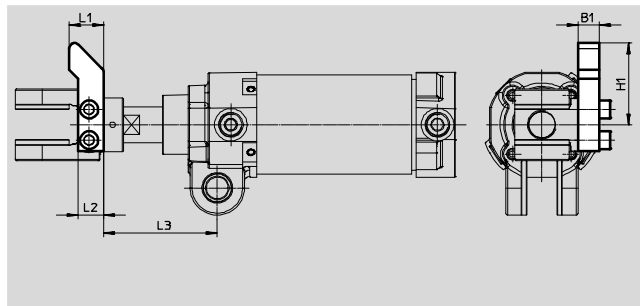

Dimensions and ordering data									
For $\varnothing$	B1	H1	L1	L2	L3	Weight [g]	Part No.	Type	
50, 63	12	45.3	19	14	63	83	<b>549607</b>	<b>KTH-50/63/80</b>	
80					68.5				

# Hinge cylinders DFAW

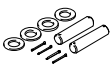

Accessories

FESTO

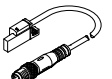
Ordering data – Mounting kit					
	Scope of delivery	For Ø	Weight [g]	Part No.	Type
	2 bolts, 2 retaining pins and 4 washers	50, 63	117	<b>573323</b>	<b>DAMD-F5-S-50</b>
		80	362	<b>573172</b>	<b>DAMD-F5-S-80</b>

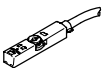
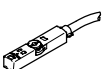
Ordering data – Proximity sensor for T-slot, magneto-resistive, welding field immune						Technical data → Internet: sdbt	
	Type of mounting	Switching output	Electrical connection	Cable length [m]	Order code	Part No.	Type
N/O contact							
	Insertable in the slot from above	Non-contacting	Cable, 2-wire	5.0	S1	<b>2427617</b>	<b>SDBT-BSW-1L-ZU-W-5-N-LE</b>
			PNP	Plug M12x1, 3-pin	0.3	S2	<b>2476855</b>
		NPN	Plug M12x1, 3-pin	0.3	S3	<b>2427615</b>	<b>SDBT-BSW-1L-NU-W-0.3-N-M12</b>
		PNP	Cable, 3-wire	5.0	S4	<b>2427616</b>	<b>SDBT-BSW-1L-PU-W-5-N-LE</b>
		NPN	Cable, 3-wire	5.0	S5	<b>2427618</b>	<b>SDBT-BSW-1L-NU-W-5-N-LE</b>

Ordering data – Proximity sensor for T-slot, magneto-resistive						Technical data → Internet: smt	
	Type of mounting	Switching output	Electrical connection	Cable length [m]	Order code	Part No.	Type
N/O contact							
	Insertable in the slot from above, flush with the cylinder profile, short design	PNP	Cable, 3-wire	2.5	S7	<b>574335</b>	<b>SMT-8M-A-PS-24V-E-2,5-OE</b>
			Plug M8x1, 3-pin	0.3	S6	<b>574334</b>	<b>SMT-8M-A-PS-24V-E-0,3-M8D</b>
			Plug M12x1, 3-pin	0.3	S8	<b>574337</b>	<b>SMT-8M-A-PS-24V-E-0,3-M12</b>
		NPN	Plug M8x1, 3-pin	0.3	S9	<b>574339</b>	<b>SMT-8M-A-NS-24V-E-0,3-M8D</b>
N/O contact, ATEX-compliant							
	Insertable in the slot from above, flush with the cylinder profile, short design	Non-contacting	Cable, 2-wire	5.0	S10	<b>574341</b>	<b>SMT-8M-A-ZS-24V-E-5,0-OE-EX2</b>

Ordering data – Connecting cables					Technical data → Internet: nebu	
	Electrical connection, left	Electrical connection, right	Cable length [m]	Part No.	Type	
	Straight socket, M8x1, 3-pin	Cable, open end, 3-wire	2.5	<b>541333</b>	<b>NEBU-M8G3-K-2.5-LE3</b>	
			5	<b>541334</b>	<b>NEBU-M8G3-K-5-LE3</b>	
	Angled socket, M8x1, 3-pin	Cable, open end, 3-wire	2.5	<b>541338</b>	<b>NEBU-M8W3-K-2.5-LE3</b>	
			5	<b>541341</b>	<b>NEBU-M8W3-K-5-LE3</b>	
	Angled socket, M12x1, 5-pin	Cable, open end, 3-wire	2.5	<b>541363</b>	<b>NEBU-M12G5-K-2.5-LE3</b>	
			5	<b>541364</b>	<b>NEBU-M12G5-K-5-LE3</b>	