



- 安装和拆卸简便可靠
- 可带 R、G 和公制螺纹
- 派生型众多：  
标准型、mini、金属型、不锈钢型、阻燃型
- QSM-B 和 QS-B 包装数量更大，价格更具吸引力

符合 ATEX

指令的特定型式，可用于有潜在爆炸危险的工作环境



→ [www.festo.com/en/ex](http://www.festo.com/en/ex)

# 快插/螺纹接头 QS

主要特性

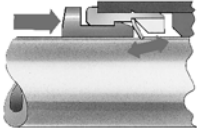
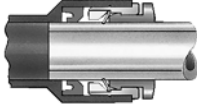
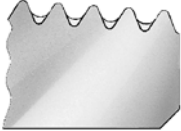

应用	只需“即插即用”	可靠连接	内附密封
 <p>轻松选择适用的接头。QS为每一种连接都提供了牢固的解决方案。便捷的快插/螺纹接头系统包括了超过1000种的标准型和功能接头。</p>	 <p>接头上的不锈钢夹爪可牢牢固定住气缸，而不会伤及气管表面。并可安全吸收振动和气压涌动。按下蓝色的解卸环。出于便利性考虑，相对应的气管外径标注于解卸环上。</p>	 <p>丁腈橡胶密封圈保证了标准外径气管和接头之间完美的密封。标准气管适合用于压缩空气和真空。</p>	 <p>Festo快插/螺纹接头所有的铜质部件都经镀镍，因此具有非常好的耐腐蚀性。锥形ISO R螺纹带有自密封的PTFE涂层，可最多连续使用五次，而无需附加的密封元件。</p>

可 360°重新定位	360°可旋转，带滚珠轴承
 <p>在装配时就已校准。使用时能补偿气管移动。</p>	 <p>最高允许 500 rpm 的旋转速度。</p>

## 哪个接头配哪个螺纹？

### 公制平行螺纹

- 柱状公制螺纹与G螺纹相当
- 通过密封圈密封
- 前端面密封

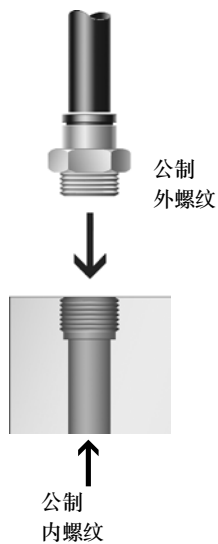

### G 平行螺纹

符合 DIN ISO 228-1

- 螺纹短
- 安装深度恒定
- 密封圈可替换
- 前端面密封
- 由于密封圈可替换，故可多次使用

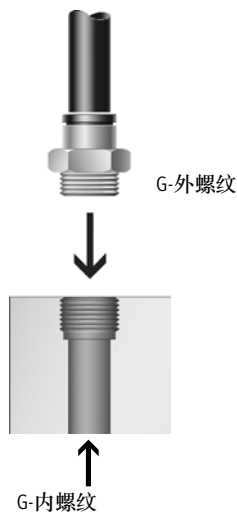

### R 锥形螺纹

符合 DIN 2999-1 和 ISO 7/1

- 自密封螺纹
- 通过涂层螺纹密封
- 无需额外的密封表面
- 密封圈表面无需槽口，安装尺寸更紧凑
- 最多可使用五次

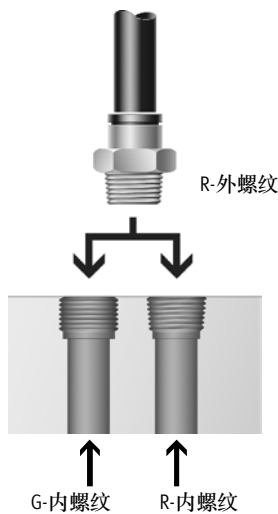

# 快插/螺纹接头 QS

主要特性

FESTO

## 快插/螺纹接头 QSM QS, mini



小型快插/螺纹接头用于在最有限的安装空间内实现最大程度的装配。适用于温度范围最高80°C和压力范围最高14 bar的应用场合。  
适用气管外径3、4和6 mm，带连接螺纹 M3, M5, M7, R $\frac{1}{8}$  和 G $\frac{1}{8}$ 。

## 快插/螺纹接头 QS QS, 标准型



众多快插/螺纹接头可选用于温度范围最高80°C和压力范围最高14 bar的应用场合。  
适用气管外径4, 6, 8, 10, 12 和 16 mm，带连接螺纹 R $\frac{1}{8}$  ... R $\frac{1}{2}$  和 G $\frac{1}{8}$  ... G $\frac{1}{2}$ 。

## 快插/螺纹接头 QSM-B QS, mini



小型快插/螺纹接头用于在最有限的安装空间内实现最大程度的装配。适用于温度范围最高60°C和压力范围最高10bar的应用场合。  
适用气管外径3、4和6 mm，带连接螺纹 M3, M5, M7, R $\frac{1}{8}$  和 G $\frac{1}{8}$ 。

## 快插/螺纹接头 QS-B QS, 标准型



快插/螺纹接头温度范围最高60°C和压力范围最高10bar的核心气动应用场合。  
适用气管外径4, 6, 8, 10, 12 和 16 mm，带连接螺纹 R $\frac{1}{8}$  ... R $\frac{1}{2}$ 。

## 快插/螺纹接头 QS-F QS, 金属型



金属型快插/螺纹接头带镀铬表面涂层。耐腐蚀防护等级 (CRC3) 和耐受化学品保护，可用于食品和包装行业。适用于温度范围最高150°C和压力范围最高16bar的应用场合。  
适用气管外径4, 6, 8, 10, 12 和 16 mm，带连接螺纹 M5, M7 和 G $\frac{1}{8}$  ... G $\frac{1}{2}$ 。

## 快插/螺纹接头 CRQS QS, 不锈钢型



不锈钢型快插/螺纹接头。耐腐蚀防护等级 (CRC4) 和耐受化学品保护，可用于食品和包装行业。适用于温度范围最高120°C和压力范围最高10bar的应用场合。  
适用气管外径4, 6, 8, 10, 12 和 16 mm，带连接螺纹 M5 和 R $\frac{1}{8}$  ... R $\frac{1}{2}$ 。

## 快插/螺纹接头 QS-V0 QS, 阻燃型



阻燃型快插/螺纹接头适用于具有火患风险的区域，例如汽车行业和建筑行业中的焊接系统。适用于温度范围最高60°C和压力范围最高10bar的应用场合。  
适用气管外径4, 6, 8, 10, 12 和 16 mm，带连接螺纹 R $\frac{1}{8}$  ... R $\frac{1}{2}$  和 G $\frac{1}{8}$  ... G $\frac{1}{2}$ 。

# 快插/螺纹接头 QS

技术参数

FESTO

## 材料

剖面图

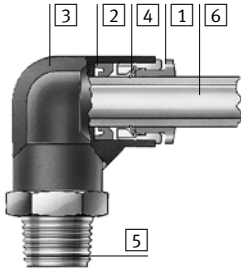

	Mini QSM 标准型 QS	Mini QSM-B 标准型 QS-B
1 拆卸圈	聚醋酸酯	聚醋酸酯
2 密封件	丁腈橡胶	丁腈橡胶
3 主体	聚丁烯酯 镀镍黄铜	聚丁烯酯 镀镍黄铜
4 气管固定夹	高合金不锈钢	高合金不锈钢
5 螺纹接口	镀镍黄铜	镀镍黄铜 M3: 不锈钢
6 塑料气管 标准外径	PAN PEN PUN PUN-H PUN-E	PAN PEN PUN PUN-H PUN-E
材料注意事项	符合RoHS规定	符合RoHS规定

	金属型 QS-F	不锈钢型 CRQS	阻燃型 QS-V0
1 拆卸圈	镀镍, 铬酸处理黄铜	高合金不锈钢	聚丁烯酯(阻燃型)
2 密封件	氟碳橡胶	氟碳橡胶	丁腈橡胶
3 主体	镀镍, 铬酸处理黄铜	高合金不锈钢	聚丁烯酯(阻燃型)
4 气管固定夹	不锈钢	高合金不锈钢	不锈钢
5 螺纹接口	镀镍, 铬酸处理黄铜 (螺纹密封件: 氟碳橡胶)	高合金不锈钢	镀镍黄铜
6 塑料气管 标准外径	PAN PFAN PUN PUN-H PUN-V0 PLN	PFAN PUN-H PLN PUN-V0	PAN-V0
材料注意事项	-	符合RoHS规定	-

## 气管插入深度

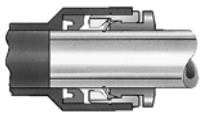

气管外径 [mm]	3	4	6	8	10	12	16
Mini QSM	9.5	11.5	12	-	-	-	-
标准型 QS	-	15 (QSW: 12)	17 (QSW: 12)	18	20.5	23.5	24.5
Mini QSM-B	-	11.5	12	-	-	-	-
标准型 QS-B	-	14.9	16.9	18.3	20.7	23.2	-

# 快插/螺纹接头 QS

技术参数

## 建议紧固扭矩/旋入深度



使用带内六角QS快插/螺纹接头时，确保六角扳手插入深度不会过深，以便接头里面的元件受到损坏。

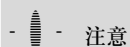

注意

功能接头的旋入深度过深时就会发生故障。必须遵守建议旋入深度和紧固扭矩。如果超过建议旋入深度和紧固扭矩的50%，就可能会导致损坏。

连接螺纹	紧固扭矩 [Nm]	旋入深度约值 [mm]
<b>M 螺纹</b>		
M3	0.7	2.5
M5	1.5	3
M7	2	5.5
<b>R 螺纹</b>		
R1/8	7	4
R1/4	12	6
R3/8	22	6.5
R1/2	28	8
<b>G 螺纹</b>		
G1/8	10	4.6
G1/4	15	6.6
G3/8	25	8.1
G1/2	40	11.1

## 工作和环境条件

	Mini QSM	标准型 QS	Mini QSM-B	标准型 QS-B
随温工作压力 [bar]	-0.95 ... +14		-0.95 ... +10	
环境温度 [°C]	-10 ... +80		0 ... 60	
耐腐蚀等级 CRC <sup>1)</sup>	1		1	
认证	德国劳氏		德国劳氏	

	金属型 QS-F	不锈钢 CRQS	阻燃型 QS-V0
随温工作压力 [bar]	-0.95 ... +16	-0.95 ... +10	-0.95 ... +10
环境温度 [°C]	0 ... 150 (-20 ... +150) <sup>2)</sup>	-15 ... +120	0 ... 60
耐腐蚀等级 CRC <sup>1)</sup>	3	4	2
食品行业认证	FDA	-	-
认证	德国劳氏	德国劳氏	德国劳氏
	-	-	UL - Recognized (OL)

- CRC1: 耐腐蚀等级 1, 符合Festo 940 070标准  
 元件只需具备低度耐腐蚀能力, 运输和贮存防护。这些元件无表面基本涂层要求, 譬如: 内部元件或位于盖子下面的元件。  
 CRC2: 耐腐蚀等级 2, 符合Festo 940 070标准  
 元件必须具备一定的耐腐蚀能力, 外部可视元件具备基本的涂层表面, 可直接与工业环境或与冷却液、润滑剂等介质接触。  
 CRC3: 耐腐蚀等级 3, 符合Festo 940 070标准  
 元件必须具备较强的耐腐蚀能力, 由于外部可视元件直接与工业环境或与溶剂、清洁剂等介质接触, 因此对元件表面有较强的耐腐蚀性要求。  
 CRC4: 耐腐蚀等级 4, 符合Festo 940 070标准  
 元件必须具备很强的耐腐蚀能力, 因为元件用于腐蚀性介质中, 例如在食品或在化工行业中, 如果需要的话, 在应用前应该对元件与介质一起进行特别的测试。
- 2) 括号内数值适用于快插接头QS-F与气管PLN的组合。

# 快插/螺纹接头 QS

技术参数

FESTO

## 工作压力 $p$ 与温度 $t$ 的关系

Mini QSM

标准型 QS

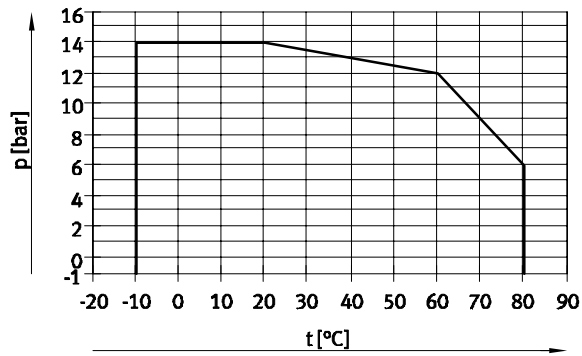

Mini QSM-B

标准型 QS-B

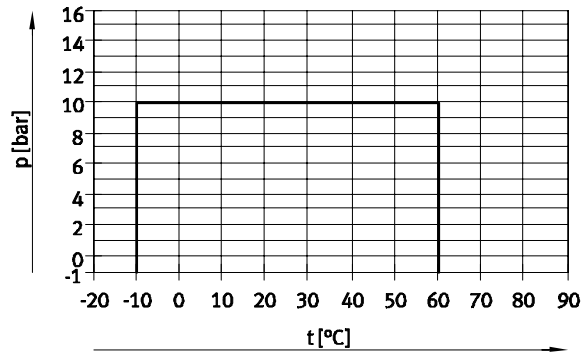

# 快插/螺纹接头 QS

技术参数

FESTO

快插/螺纹接头与气管的可用组合								
型号	螺纹	气管外径 [mm]						
		3	4	6	8	10	12	16
Mini QSM	M3	++	+	-	-	-	-	-
	M5	+	++	+	-	-	-	-
	M6	-	++	-	-	-	-	-
	M7	-	+	++	-	-	-	-
	M8	-	-	++	-	-	-	-
	R $\frac{1}{8}$	-	+	++	-	-	-	-
	G $\frac{1}{8}$	-	+	++	-	-	-	-
标准型 QS	M5	-	++	+	-	-	-	-
	R $\frac{1}{8}$	-	+	++	+	+	-	-
	R $\frac{1}{4}$	-	+	+	+	+	+	-
	R $\frac{3}{8}$	-	-	+	+	++	+	+
	R $\frac{1}{2}$	-	-	-	-	-	++	-
	G $\frac{1}{8}$	-	+	++	+	-	-	-
	G $\frac{1}{4}$	-	-	+	++	+	+	-
	G $\frac{3}{8}$	-	-	-	+	++	+	+
G $\frac{1}{2}$	-	-	-	-	-	++	+	
Mini QSM-B	M3	++	+	-	-	-	-	-
	M5	+	++	+	-	-	-	-
	M7	-	+	++	-	-	-	-
标准型 QS-B	R $\frac{1}{8}$	-	+	++	+	+	-	-
	R $\frac{1}{4}$	-	+	+	++	+	+	-
	R $\frac{3}{8}$	-	-	+	+	++	+	+
	R $\frac{1}{2}$	-	-	-	-	+	++	+
阻燃型 QS-V0	R $\frac{1}{8}$	-	-	++	+	-	-	-
	R $\frac{1}{4}$	-	-	+	++	+	+	-
	R $\frac{3}{8}$	-	-	-	+	++	+	-
	R $\frac{1}{2}$	-	-	-	-	+	++	-
	G $\frac{1}{8}$	-	-	++	+	-	-	-
	G $\frac{1}{4}$	-	-	+	++	+	+	-
	G $\frac{3}{8}$	-	-	-	+	++	+	-
G $\frac{1}{2}$	-	-	-	-	+	++	-	
金属型 QS-F	M5	-	++	+	-	-	-	-
	M7	-	+	++	-	-	-	-
	G $\frac{1}{8}$	-	+	++	+	-	-	-
	G $\frac{1}{4}$	-	-	+	++	+	-	-
	G $\frac{3}{8}$	-	-	-	+	++	+	-
	G $\frac{1}{2}$	-	-	-	-	+	++	-
不锈钢 CRQS	M5	-	++	+	-	-	-	-
	R $\frac{1}{8}$	-	-	++	+	-	-	-
	R $\frac{1}{4}$	-	-	-	++	+	-	-
	R $\frac{3}{8}$	-	-	-	-	++	+	-
	R $\frac{1}{2}$	-	-	-	-	-	++	+













+ 螺纹/气管外径的可用组合

++ 螺纹/气管外径的最佳组合（相对于流量）

# 快插/螺纹接头 QSM, mini

产品范围一览

FESTO













结构特点	类型	型号	接口 D1				接口 D2		→ 页码
			M 螺纹	R 螺纹	G 螺纹	气管外径	插入式轴套 ∅	气管外径	
直列式	<b>快插/螺纹接头 - 外螺纹, 带外六角</b>								
		QSM	M3	-	-	-	-	3, 4	26
			M5					3, 4, 6	
			M6					6	
		QSM	-	R1/8	G1/8	-	-	4, 6	
	<b>快插/螺纹接头 - 外螺纹, 带内六角</b>								
		QSM-...-I	M3	-	-	-	-	3, 4	27
			M5					3, 4, 6	
			M7	R1/8	G1/8			4, 6	
	<b>快插/螺纹接头 - 外螺纹, 带内六角</b>								
		QSM-...-I-R	M3	-	-	-	-	3, 4	28
			M5					3, 4, 6	
			M7					6	
	<b>快插/螺纹接头 - 内螺纹, 带外六角</b>								
		QSMF	M3	-	-	-	-	3, 4	29
			M5					3, 4	
	<b>快插/螺纹接头 - 外螺纹, 带内六角</b>								
		QSMF	M6x0.75	-	-	-	-	4	29
	M8x0.75						6		
<b>快插接头</b>									
	QSM	-	-	-	3	-	3	30	
						4	4		
						6	6		
	QSM 变径	-	-	-	4	-	3	30	
						6	4		
<b>穿板式快插接头</b>									
	QSMS	-	-	-	3	-	-	30	
						4			
						6			
<b>快插堵头</b>									
	QSMC	-	-	-	3	-	-	31	
<b>快插接头, 带轴套</b>									
	QSM-...H	-	-	-	-	4	3	31	
							6		4
<b>堵头</b>									
	QSMC-...H	-	-	-	-	3	-	31	



# 快插/螺纹接头 QSM, mini

产品范围一览



FESTO

结构特点	类型	型号	接口 D1					接口 D2		→ 页码
			M 螺纹	R 螺纹	G 螺纹	气管外径	插入式轴套 ∅	气管外径		
L形	<b>L形快插/螺纹接头, 可旋转360° - 外螺纹, 带外六角</b>									
		QSML	M3	-	-	-	-	3, 4	32	
			M5					3, 4, 6		
			M7	R1/8	G1/8			4, 6		
	<b>加长 L形快插/螺纹接头, 可旋转360° - 外螺纹, 带外六角</b>									
		QSMLL	M3	-	-	-	-	3, 4	33	
			M5					3, 4, 6		
			M7	R1/8	G1/8			4, 6		
	<b>L形快插/螺纹接头, 可旋转360° - 外螺纹, 带内六角</b>									
		QSMLV-...-I	M5	-	-	-	-	3, 4	34	
			M7					4, 6		
	<b>加长 L形快插/螺纹接头, 可旋转360° - 外螺纹, 带内六角</b>									
	QSMLLV-...-I	M5	-	-	-	-	3, 4	34		
		M7					4, 6			
<b>L形快插接头</b>										
	QSML	-	-	-	3	-	-	35		
		4								
		6								
<b>L形快插接头, 带轴套</b>										
	QSML-...H	-	-	-	-	3	3	35		
		4					4			
		6					6			
	QSML-...H 变径	-	-	-	-	4	3	35		
		6					4			
T形	<b>T形快插/螺纹接头, 可旋转360° - 外螺纹, 带外六角</b>									
		QSMT	M3	-	-	-	-	3, 4	36	
			M5					3, 4, 6		
			-	R1/8	G1/8			4, 6		
		QSMTL	M3	-	-	-	-	3, 4	37	
			M5					3, 4, 6		
			-	R1/8	G1/8			4, 6		
	<b>T形快插接头</b>									
	QSMT	-	-	-	3	-	3	38		
		4					4			
		6					6			
	QSMT 变径	-	-	-	4	-	3	38		
		6					4			
X形	<b>X形快插接头</b>									
		QSMX	-	-	-	3	-	-	39	
			4							
			6							
	6									

# 快插/螺纹接头 QSM, mini

产品范围一览









FESTO

结构特点	类型	型号	接口 D1				气管外径	插入式轴套 Ø	接口 D2	→ 页码
			M 螺纹	R 螺纹	G 螺纹	气管外径				
Y形	Y形快插接头									
		QSMY	-	-	-	3	-	3	39	
			-	-	-	4	4			
			-	-	-	6	6			
		QSMY 变径	-	-	-	4	-	3	39	
			-	-	-	6	4			

# 快插/螺纹接头 QS, 标准型

产品范围一览











结构特点	类型	型号	接口 D1				接口 D2		→ 页码	
			M 螺纹	R 螺纹	G 螺纹	气管外径	插入式轴套 Ø	气管外径		插入式轴套 Ø
直列式	<b>快插/螺纹接头 - 外螺纹, 带外六角</b>									
		QS	-	R1/8 R1/4 R3/8 R1/2	G1/8 G1/4 G3/8 G1/2	-	-	4, 6, 8, 10 <sup>1)</sup> 4 <sup>1)</sup> , 6, 8, 10, 12 6 <sup>1)</sup> , 8, 10, 12, 16 10 <sup>1)</sup> , 12, 16	-	40
	<b>快插/螺纹接头 - 外螺纹, 带内六角</b>									
		QS-...-I	-	R1/8 R1/4 R3/8 R1/2	G1/8 G1/4 G3/8 G1/2	-	-	4, 6, 8, 10 <sup>1)</sup> 6, 8, 10, 12 <sup>1)</sup> 8, 10, 12 10 <sup>1)</sup> , 12	-	42
	<b>快插/螺纹接头 - 内螺纹, 带外六角</b>									
		QSF	-	-	G1/8 G1/4 G3/8 G1/2	-	-	4, 6, 8 4, 6, 8, 10, 12 6, 8, 10, 12 12, 16	-	43
	<b>快插接头</b>									
		QS	-	-	-	4 6 8 10 12 16	-	4 6 8 10 12 16	-	44
		QS 变径	-	-	-	6 8 10 12	-	4 4, 6 6, 8 8, 10	-	44
	<b>穿板式快插接头</b>									
	QSS	-	-	-	4 6 8 10 12	-	-	-	45	
<b>穿板式快插接头, 带固定环</b>										
	QSS-...-F	-	-	-	4 6 8 10 12	-	-	-	45	
<b>穿板式快插/螺纹接头, 带内螺纹</b>										
	QSSF	-	-	G1/8 G1/4 G3/8 G1/2	-	-	4, 6, 8 4, 6, 8, 10 6, 8, 10, 12 12, 16	-	46	

1) 只能与R 螺纹组合

# 快插/螺纹接头 QS, 标准型

产品范围一览

FESTO









结构特点	类型	型号	接口 D1				接口 D2				→ 页码
			M 螺纹	R 螺纹	G 螺纹	气管外径	插入式轴套 Ø	气管外径	插入式轴套 Ø		
直列式	<b>插入式堵头</b>										
		QSC	-	-	-	4	-	-	-	47	
						6					
						8					
						10					
						12					
	<b>快插接头, 带轴套</b>										
		QS-...H	-	-	-	-	6	4	-	47	
							8	4, 6			
							10	6, 8			
						12	8, 10				
<b>插入式轴套</b>											
	QSH	-	-	-	-	4	-	-	48		
						6					
						8					
						10					
						12					
						16					
	QSH 变径	-	-	-	-	6	-	4	48		
						8		4, 6			
						10		6, 8			
						12		8, 10			
						16		12			
<b>堵头</b>											
	QSC-...H	-	-	-	-	4	-	-	49		
						6					
						8					
						10					
						12					
						16					
L形	<b>L形快插/螺纹接头, 可旋转 360° - 外螺纹, 带外六角</b>										
		QSL	-	R <sup>1</sup> / <sub>8</sub>	G <sup>1</sup> / <sub>8</sub>	-	-	4, 6, 8, 10 <sup>1)</sup>	-	50	
				R <sup>1</sup> / <sub>4</sub>	G <sup>1</sup> / <sub>4</sub>			4 <sup>1)</sup> , 6, 8, 10, 12			
				R <sup>3</sup> / <sub>8</sub>	G <sup>3</sup> / <sub>8</sub>			6 <sup>1)</sup> , 8, 10, 12, 16			
				R <sup>1</sup> / <sub>2</sub>	G <sup>1</sup> / <sub>2</sub>			10 <sup>1)</sup> , 12, 16			
	<b>加长L形快插/螺纹接头, 可旋转 360° - 外螺纹, 带外六角</b>										
		QSLL	-	R <sup>1</sup> / <sub>8</sub>	G <sup>1</sup> / <sub>8</sub>	-	-	4, 6, 8	-	52	
				R <sup>1</sup> / <sub>4</sub>	G <sup>1</sup> / <sub>4</sub>			4 <sup>1)</sup> , 6, 8, 10, 12 <sup>2)</sup>			
				R <sup>3</sup> / <sub>8</sub>	G <sup>3</sup> / <sub>8</sub>			6 <sup>1)</sup> , 8, 10, 12			
				R <sup>1</sup> / <sub>2</sub>	G <sup>1</sup> / <sub>2</sub>			10 <sup>1)</sup> , 12, 16 <sup>2)</sup>			
<b>L形快插/螺纹接头 - 内螺纹, 带外六角</b>											
	QSLF	-	-	G <sup>1</sup> / <sub>8</sub>	-	-	4, 6, 8	-	53		
				G <sup>1</sup> / <sub>4</sub>			6, 8, 10				
				G <sup>3</sup> / <sub>8</sub>			8, 10				

1) 只能与 R 螺纹组合  
2) 只能与 G 螺纹组合

# 快插/螺纹接头 QS, 标准型

产品范围一览

FESTO

结构特点	类型	型号	接口 D1				接口 D2		→ 页码	
			M 螺纹	R 螺纹	G 螺纹	气管外径	插入式轴套 Ø	气管外径		插入式轴套 Ø
L形	<b>L形快插/螺纹接头, 可旋转 360° - 外螺纹, 带内六角</b>									
		QSLV-....I	-	R1/8 R1/4 R3/8 R1/2	G1/8 G1/4 G3/8 G1/2	-	-	6, 8 6, 8, 10 8, 10, 12 12	-	54
	<b>L形快插/螺纹接头, 可旋转 360° - 外螺纹, 带外六角</b>									
		QSLV	M5 -	- R1/8 R1/4 R3/8 R1/2	- G1/8 G1/4 G3/8 G1/2	-	-	6 4, 6, 8 6, 8, 10 8, 10, 12 12, 16	-	55
	<b>中空复合式分气接头, 可旋转 360° - 2 个排气口</b>									
		QSLV2	-	R1/8 R1/4 R3/8 R1/2	G1/8 G1/4 G3/8 G1/2	-	-	4, 6, 8 6, 8, 10 8, 10, 12 12	-	qslv
	<b>中空复合式分气接头, 可旋转 360° - 3 个排气口</b>									
		QSLV3	-	R1/8 R1/4 R3/8 R1/2	G1/8 G1/4 G3/8 G1/2	-	-	4, 6, 8 6, 8, 10 8, 10, 12 12	-	qslv
	<b>中空复合式分气接头, 可旋转 360° - 4 个排气口</b>									
		QSLV4	-	R1/8 R1/4 R3/8 R1/2	G1/8 G1/4 G3/8 G1/2	-	-	4, 6, 8 6, 8, 10 8, 10, 12 12	-	qslv
	<b>中空复合式分气接头, 可旋转 360° - 6 个排气口</b>									
		QSLV6	-	R1/8 R1/4 R3/8 R1/2	G1/8 G1/4 G3/8 G1/2	-	-	4, 6, 8 6, 8, 10 8, 10, 12 12	-	qslv
<b>中空复合式分气接头, 可旋转 360° - 4 个排气口</b>										
	QSQ	-	R1/8 R1/4	G1/8 G1/4	-	-	4, 6 4, 6	-	qsq	
	QSQ 变径	-	-	-	6 8	-	4 6	-	qsq	

# 快插/螺纹接头 QS, 标准型

产品范围一览





结构特点	类型	型号	接口 D1				接口 D2		→ 页码	
			M 螺纹	R 螺纹	G 螺纹	气管外径	插入式轴套 Ø	气管外径		插入式轴套 Ø
L形	<b>L形快插接头</b>									
		QSL	-	-	-	4	-	-	-	57
						6				
						8				
						10				
						12				
						16				
	<b>L形快插接头, 带轴套</b>									
		QSL-...H	-	-	-	-	4	4	-	58
							6	6		
							8	8		
							10	10		
							12	12		
	QSL-...H 变径	-	-	-	-	6	4	-	58	
						8	6			
						10	8			
						12	10			
	QSL-...HL 加长 插入式轴套	-	-	-	-	4	4	-	58	
						6	6			
						8	8			
						10	10			
						12	12			
T形	<b>T形快插/螺纹接头, 可旋转 360° - 外螺纹, 带外六角</b>									
		QST	-	R $\frac{1}{8}$	G $\frac{1}{8}$	-	-	4, 6, 8, 10 <sup>1)</sup>	-	59
				R $\frac{1}{4}$	G $\frac{1}{4}$			4 <sup>1)</sup> , 6, 8, 10, 12		
				R $\frac{3}{8}$	G $\frac{3}{8}$			6 <sup>1)</sup> , 8, 10, 12, 16		
				R $\frac{1}{2}$	G $\frac{1}{2}$			10, <sup>1)</sup> 12, 16		
	<b>T形快插接头</b>									
		QST	-	-	-	4	-	4	-	61
						6		6		
						8		8		
						10		10		
						12		12		
						16		16		
	QST 变径	-	-	-	6	-	4	-	61	
					8		4, 6			
					10		6, 8			
					12		8, 10			
					16		12			





1) 只能与 R 螺纹组合

# 快插/螺纹接头 QS, 标准型

产品范围一览

FESTO

结构特点	类型	型号	接口 D1				接口 D2		接口 D3	→ 页码
			R 螺纹	G 螺纹	气管外径	插入式轴套 Ø	气管外径	插入式轴套 Ø	气管外径	
T形	中空复合式分气接头, 可旋转 360° - 3 个排气口									
		QST3	R1/8	G1/8	-	-	6	-	4	qst
		R1/4	G1/4			8		6		
		R3/8	G3/8			10		8		
		QST3 变径	-	-	6	-	6	-	4	qst
					8		8		6	
					10		10		8	

结构特点	类型	型号	接口 D1				接口 D2		→ 页码	
			M 螺纹	R 螺纹	G 螺纹	气管外径	插入式轴套 Ø	气管外径		插入式轴套 Ø
T形	T形快插/螺纹接头, 可旋转 360° - 外螺纹和内螺纹, 带外六角									
		QSTF	-	R1/8	G1/8	-	-	4, 6, 8	-	62
			R1/4	G1/4			6, 8, 10			
			R3/8	G3/8			8, 10, 12			
			R1/2	G1/2			12			
T形	T形快插/螺纹接头, 可旋转 360° - 外螺纹, 带外六角									
		QSTL	-	R1/8	G1/8	-	-	4, 6, 8	-	63
			R1/4	G1/4			6, 8, 10			
			R3/8	G3/8			8, 10, 12			
			R1/2	G1/2			12, 16			
直角式	快插/螺纹接头 - 外螺纹, 带外六角									
		QSW	-	R1/8	-	-	-	4, 6, 8	-	65
			R1/4				6, 8, 10			
			R3/8				10, 12			
			R1/2				12, 16			
直角式	快插接头, 带轴套									
		QSW-HL	-	-	-	-	4	4	-	65
						6	6			
						8	8			
						10	10			
						12	12			
X形	X形快插接头									
		QSX	-	-	-	8	-	-	-	66
					10					
					12					

# 快插/螺纹接头 QS, 标准型

产品范围一览



结构特点	类型	型号	接口 D1				接口 D2			→ 页码
			M 螺纹	R 螺纹	G 螺纹	气管外径	插入式轴套 Ø	气管外径	插入式轴套 Ø	
Y形	Y形快插/螺纹接头, 可旋转 360° - 外螺纹, 带外六角									
		QSY	M5	-	-	-	-	4, 6	-	67
				R1/8	G1/8			4, 6, 8		
				R1/4	G1/4			4 <sup>1)</sup> , 6, 8, 10		
				R3/8	G3/8			8, 10, 12		
				R1/2	G1/2			12		
	Y形快插接头									
		QSY	-	-	-	4	-	4	-	69
						6		6		
						8		8		
						10		10		
						12		12		
		QSY 变径	-	-	-	6	-	4	-	69
						8		4, 6		
						10		6, 8		
					12		8, 10			
					16		12			
Y形快插接头, 带轴套										
	QSY-...H	-	-	-	-	4	4	-	70	
						6	6			
						8	8			
						10	10			
						12	12			
	QSY-...H 变径	-	-	-	-	6	4	-	70	
						8	6			
						10	8			
						12	10			
Y形快插/螺纹接头, 可旋转 360° - 外螺纹, 带外六角										
	QSYL	-	R1/8	G1/8	-	-	4, 6, 8	-	71	
			R1/4	G1/4			6, 8, 10			
			R3/8	G3/8			8, 10, 12			
			R1/2	G1/2			12			
Y形快插/螺纹接头, 可旋转 360° - 外螺纹, 带外六角										
	QSYLV	-	R1/8	G1/8	-	-	6	-	72	
			R1/4	G1/4			8			
			R3/8	G3/8			10			
			R1/2	G1/2			12			
Y形快插/螺纹接头 - 外螺纹和内螺纹, 带外六角										
	QSYTF	-	R1/8	G1/8	-	-	6	-	73	
			R1/4	G1/4			8			
			R3/8	G3/8			10			
			R1/2	G1/2			12			
拆卸工具										
	快速拆卸工具, 用于QS快插/螺纹接头和快插接头	QSO	-	-	-	-	-	-	114	

1) 只能与 R 螺纹组合



# 快插/螺纹接头 QSM-B, mini

产品范围一览

FESTO

结构特点	类型	型号	接口 D1		接口 D2	→ 页码
			M 螺纹	R 螺纹	气管外径	
直列式	<b>快插/螺纹接头 - 外螺纹, 带外六角</b>					
		QSM-B	M3	-	3, 4	74
			M5		3, 4, 6	
			-	R $\frac{1}{8}$	4, 6	
	<b>快插/螺纹接头 - 外螺纹, 带内六角</b>					
	QSM-B-...-I	M3	-	3, 4	75	
		M5		3, 4, 6		
		M7		4, 6		
		-	R $\frac{1}{8}$	4, 6		
L形	<b>L形快插/螺纹, 可旋转 360° - 外螺纹, 带外六角</b>					
		QSML-B	M3	-	3, 4	76
			M5		3, 4, 6	
			M7		4, 6	
			-		R $\frac{1}{8}$	
<b>T形快插/螺纹, 可旋转 360° - 外螺纹, 带外六角</b>						
	QSMT-B	M3	-	3, 4	77	
		M5		3, 4, 6		
		-	R $\frac{1}{8}$	4, 6		

# 快插/螺纹接头 QS-B

产品范围一览

FESTO

结构特点	类型	型号	接口 D1			接口 D2		→ 页码
			M 螺纹	R 螺纹	气管外径	气管外径		
直列式	<b>快插/螺纹接头 - 外螺纹, 带外六角</b>							
		QS-B	-	R1/8	-	4, 6, 8, 10	78	
				R1/4		4, 6, 8, 10, 12		
				R3/8		6, 8, 10, 12, 16		
				R1/2		10, 12, 16		
	<b>快插/螺纹接头 - 外螺纹, 带内六角</b>							
		QS-B-...I	-	R1/8	-	4, 6, 8, 10	79	
				R1/4		6, 8, 10, 12		
				R3/8		8, 10, 12		
				R1/2		10, 12		
<b>快插接头</b>								
	QS-B	-	-	4	4	80		
				6	6			
				8	8			
				10	10			
				12	12			
				16	16			
	QS-B 变径	-	-	6	4	80		
				8	4, 6			
				10	6, 8			
				12	8, 10			
L形	<b>L形快插/螺纹接头, 可旋转 360° - 外螺纹, 带外六角</b>							
		QSL-B	-	R1/8	-	4, 6, 8, 10	81	
				R1/4		4, 6, 8, 10, 12		
				R3/8		6, 8, 10, 12, 16		
				R1/2		10, 12, 16		
	<b>加长L形快插/螺纹接头, 可旋转 360° - 外螺纹, 带外六角</b>							
		QSL-B	-	R1/8	-	4, 6, 8	82	
				R1/4		6, 8, 10		
				R3/8		6, 8, 10, 12		
				R1/2		10, 12		
<b>L形快插接头</b>								
	QSL-B	-	-	4	-	82		
				6				
				8				
				10				
				12				
				16				
T形	<b>T形快插/螺纹接头, 可旋转 360° - 外螺纹, 带外六角</b>							
		QST-B	-	R1/8	-	4, 6, 8, 10	83	
				R1/4		4, 6, 8, 10, 12		
				R3/8		6, 8, 10, 12, 16		
				R1/2		10, 12, 16		

# 快插/螺纹接头 QS-B







产品范围一览

结构特点	类型	型号	接口 D1			接口 D2		→ 页码
			M 螺纹	R 螺纹	气管外径	气管外径		
T形	<b>T形快插接头</b>							
		QST-B	-	-	-	4	4	84
						6	6	
						8	8	
						10	10	
						12	12	
						16	16	
	<b>T形快插/螺纹接头, 可旋转 360° - 外螺纹, 带外六角</b>							
		QSTL-B	-	R1/8	-	4, 6, 8	85	
						R1/4		4, 6, 8
						R3/8		6, 8, 10, 12
						R1/2		10, 12, 16
Y形	<b>Y形快插/螺纹接头, 可旋转 360° - 外螺纹, 带外六角</b>							
		QSY-B	M5	-	-	4, 6	86	
			-	R1/8	-	4, 6, 8		
			-	R1/4	-	4, 6, 8, 10		
			-	R3/8	-	6, 8, 10, 12		
			-	R1/2	-	10, 12		
	<b>Y形快插接头</b>							
		QSY-B	-	-	-	4	4	87
						6	6	
						8	8	
						10	10	
						12	12	
	QSY-B 变径	-	-	-	6	4	87	
					8	4, 6		
					10	6, 8		
					12	8, 10		
					16	12		

# 快插/螺纹接头 QS-F, 金属型

产品范围一览

FESTO

结构特点	类型	型号	接口 D1				接口 D2			→ 页码
			M 螺纹	R 螺纹	G 螺纹	气管外径	插入式轴套 Ø	气管外径	插入式轴套 Ø	
直列式	<b>快插/螺纹接头 - 外螺纹, 带外六角</b>									
		QS-F	M5 M7 -	-	- - G1/8 G1/4 G3/8 G1/2	-	-	4, 6 4, 6 4, 6, 8 6, 8, 10, 12 8, 10, 12 10, 12	-	88
	<b>快插/螺纹接头 - 外螺纹, 带内六角</b>									
		QS-F-...I	M5 M7 -	-	- - G1/8 G1/4 G3/8	-	-	4, 6 4, 6 4, 6, 8 8, 10 12	-	89
	<b>快插/螺纹接头 - 内螺纹, 带外六角</b>									
		QSF-F	-	-	G1/8 G1/4	-	-	4, 6, 8 4, 6, 8	-	89
	<b>穿板式快插/螺纹接头 - 内螺纹, 带外六角</b>									
		QSSF-F	-	-	G1/8 G1/4	-	-	4, 6, 8 6, 8	-	90
	<b>快插/螺纹接头, 带轴套</b>									
		QS-F-...H	M5 M7 -	-	- - G1/8 G1/4 G3/8 G1/2	-	-	-	4, 6 4, 6 4, 6, 8 6, 8, 10, 12 8, 10, 12 10, 12	91
	<b>快插接头</b>									
		QS-F	-	-	-	4 6 8 10 12	-	-	-	92
		QS-F 变径	-	-	-	6 8 12	-	4 6 8	-	92
	<b>穿板式快插接头</b>									
		QSSF-F	-	-	-	4 6 8 10 12	-	-	-	98

# 快插/螺纹接头 QS-F, 金属型

产品范围一览



结构特点	类型	型号	接口 D1				接口 D2		→ 页码		
			M 螺纹	R 螺纹	G 螺纹	气管外径	插入式轴套 ∅	气管外径		插入式轴套 ∅	
直列式	<b>快插接头, 带轴套</b>										
		QS-F...H	-	-	-	4	-	-	6	92	
						4			8		
						6			8		
						4			10		
						6			10		
						8			10		
						6			12		
						8			12		
						10			12		
<b>插入式轴套</b>											
	QSH-F	-	-	-	-	-	-	4	94		
					6						
					8						
					10						
					12						
QSH-F 变径	-	-	-	-	-	-	-	6	4	94	
								8	6		
								12	8		
<b>堵头</b>											
	QSC-F...H	-	-	-	-	-	-	4	94		
								6			
								8			
								10			
								12			
<b>锁定螺丝</b>											
	QS-F...I	M5	-	-	-	-	-	-	95		
										M7	
										-	G1/8
										-	G1/4
										-	G3/8
-	G1/2										

# 快插/螺纹接头 QS-F, 金属型

产品范围一览







FESTO

结构特点	类型	型号	接口 D1				接口 D2			→ 页码	
			M 螺纹	R 螺纹	G 螺纹	气管外径	插入式轴套 Ø	气管外径	插入式轴套 Ø		
L形	L形快插/螺纹接头, 可旋转 360° - 外螺纹, 带外六角										
		QSL-F	M5	-	-	-	-	-	4, 6	-	96
			M7						4, 6		
			-						4, 6, 8		
			G1/8						6, 8, 10, 12		
			G1/4						8, 10, 12		
			G3/8						10, 12		
	G1/2										
	加长L形快插/螺纹接头, 可旋转 360° - 外螺纹, 带外六角										
		QSL-L-F	-	-	-	-	-	4, 6, 8	-	97	
							6, 8, 10, 12				
							8, 10, 12				
							10, 12				
L形快插接头											
		QSL-F	-	-	-	4	-	-	-	98	
						6					
						8					
						10					
						12					
T形	T形快插/螺纹接头, 可旋转 360° - 外螺纹, 带外六角										
		QST-F	M5	-	-	-	-	-	4, 6	-	99
			M7						4, 6		
			-						4, 6, 8		
			G1/8						6, 8, 10, 12		
			G1/4						8, 10, 12		
			G3/8						10, 12		
	G1/2										
	T形快插接头										
			QST-F	-	-	-	4	-	4	-	100
						6		6			
						8		8			
						10		10			
						12		12			
		QST-F 变径	-	-	-	6	-	4	-	100	
						8		6			
						10		8			
						12		10			
Y形	Y形快插接头										
		QSY-F	-	-	-	6	-	6	-	100	
						8		8			
						10		10			
	QSY-F 变径	-	-	-	6	-	4	-	100		
					8		6				
					10		8				

# 快插/螺纹接头 CRQS, 不锈钢型

产品范围一览



FESTO

结构特点	类型	型号	接口 D1				接口 D2		→ 页码	
			M 螺纹	R 螺纹	G 螺纹	气管外径	插入式轴套 Ø	气管外径		插入式轴套 Ø
直列式	快插/螺纹接头 - 外螺纹, 带内六角和外六角									
		CRQS	M5x0,8	-	-	-	-	4, 6	-	101
				R1/8				4, 6, 8		
				R1/4				6, 8, 10		
				R3/8				10, 12		
				R1/2				12, 16		
	快插接头									
		CRQS	-	-	-	4	-	4	-	103
						6		6		
						8		8		
					10		10			
					12		12			
	CRQS 变径	-	-	-	6	-	4	-	103	
					8		6			
					10		8			
					12		10			
					16		12			
穿板式快插接头										
	CRQSS	-	-	-	4	-	4	-	103	
					6		6			
					8		8			
					10		10			
					12		12			
L形	L形快插/螺纹接头, 可旋转360° - 外螺纹, 带外六角									
		CRQSL	M5x0,8	-	-	-	-	4, 6	-	104
				R1/8				4, 6, 8		
				R1/4				6, 8, 10		
				R3/8				10, 12		
				R1/2				12, 16		
	L形快插接头									
		CRQSL	-	-	-	4	-	-	-	105
						6				
						8				
					10					
					12					
					16					

# 快插/螺纹接头 CRQS, 不锈钢型

产品范围一览

FESTO







结构特点	类型	型号	接口 D1				接口 D2		→ 页码
			M 螺纹	R 螺纹	G 螺纹	气管外径	插入式轴套 Ø	气管外径	
T形	T形快插/螺纹接头, 可旋转360° - 外螺纹, 带外六角								
		CRQST	M5x0,8	-	-	-	-	4, 6	-
			R1/8				6, 8		
			R1/4				8, 10		
			R3/8				10, 12		
			R1/2				12, 16		
T形	T形快插接头								
		CRQST	-	-	-	4	-	-	-
					6				
					8				
					10				
					12				
Y形	Y形快插接头								
		CRQSY	-	-	-	4	-	-	-
					6				
					8				
					10				
					12				
					16				



# 快插/螺纹接头 QS-V0, 阻燃型

产品范围一览



结构特点	类型	型号	接口 D1				接口 D2		→ 页码	
			M 螺纹	R 螺纹	G 螺纹	气管外径	插入式轴套 Ø	气管外径		插入式轴套 Ø
<b>阻燃等级 UL94V0 – 适用塑料气管 PAN/PUN-V0</b>										
直列式	<b>快插/螺纹接头 – 外螺纹, 带外六角</b>									
		QS-V0	-	R1/8 R1/4 R3/8 R1/2	G1/8 G1/4 G3/8 G1/2	-	-	4 <sup>1)</sup> , 6, 8 6, 8, 10, 12 8, 10, 12 10, 12	-	108
<b>快插接头</b>										
		QS-V0	-	-	-	4 6 8 10 12	-	-	-	109
L形	<b>L形快插/螺纹接头 – 外螺纹, 带外六角</b>									
		QSL-V0	-	R1/8 R1/4 R3/8 R1/2	G1/8 G1/4 G3/8 G1/2	-	-	4 <sup>1)</sup> , 6, 8 6, 8, 10, 12 8, 10, 12 10, 12	-	110
<b>L形快插接头</b>										
		QSL-V0	-	-	-	4 6 8 10 12	-	-	-	111
T形	<b>T形快插/螺纹接头 – 外螺纹, 带外六角</b>									
		QST-V0	-	R1/8 R1/4 R3/8 R1/2	G1/8 G1/4 G3/8 G1/2	-	-	4 <sup>1)</sup> , 6, 8 6, 8, 10, 12 8, 10, 12 10, 12	-	112
<b>T形快插接头</b>										
		QST-V0	-	-	-	4 6 8 10 12	-	-	-	113

1) 只能与 R 螺纹组合

# 快插/螺纹接头 QSM, mini

技术参数

FESTO

快插/螺纹接头 QSM  
外螺纹  
带外六角



M 螺纹

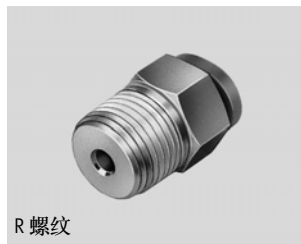
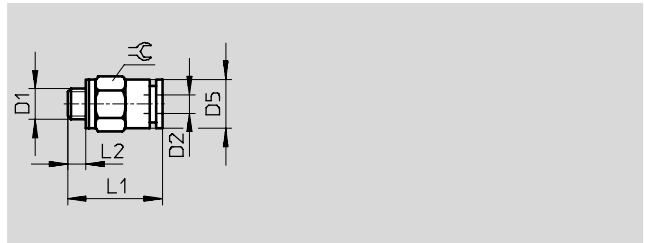

R 螺纹

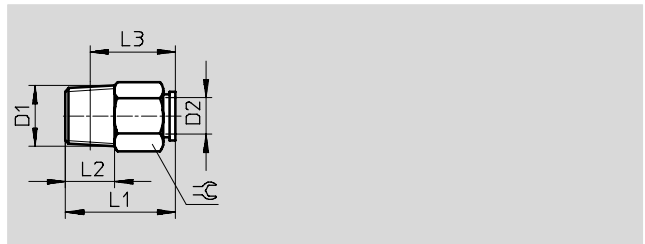

G 螺纹

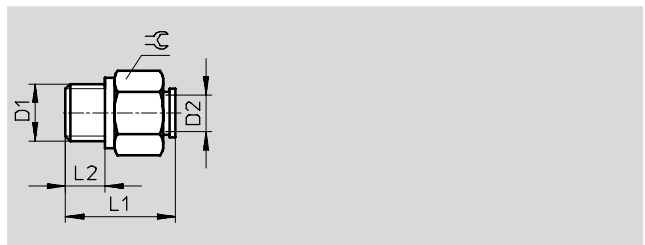

尺寸和订货数据											
接口	公称通径	气管外径	D5	L1	L2	L3	≈	每件重量	订货号	型号	PU*
D1	[mm]	D2	∅					[g]			
公制螺纹, 带密封圈											
M3	0.9	3	7	14	3.3	-	5.5	1.1	153301	QSM-M3-3	10
									130775	QSM-M3-3-100	100
	1.1	4	9.8	16.5	3.3	-	8	2.5	153303	QSM-M3-4	10
									130776	QSM-M3-4-100	100
M5	2	3	9.8	16.7	3.5	-	8	3.5	153302	QSM-M5-3	10
									130777	QSM-M5-3-100	100
	2.2	4	9.8	16.7	3.5	-	8	3.3	153304	QSM-M5-4	10
									130778	QSM-M5-4-100	100
	2.1	6	11.8	17.8	3.5	-	10	4.5	153306	QSM-M5-6	10
									130779	QSM-M5-6-100	100
M6	2.8	6	11.8	18	3.9	-	10	4.8	132600	QSM-M6-6	新产品 1
R 螺纹											
R1/8	2.9	4	-	16	8	12	10	6	153305	QSM-1/8-4	10
									130755	QSM-1/8-4-100	100
	4.5	6	-	18	8	14	10	6	153307	QSM-1/8-6	10
									130756	QSM-1/8-6-100	100
G 螺纹, 带密封圈											
G1/8	2.9	4	-	16.4	5.1	-	13	9.4	186264	QSM-G1/8-4	10
	2.8	6	-	18.4	5.1	-	13	11	186265	QSM-G1/8-6	10

\* 包装单位数量

# 快插/螺纹接头 QSM, mini

技术参数

快插/螺纹接头 QSM-...-I

外螺纹

带内六角



M 螺纹

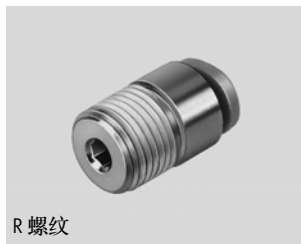
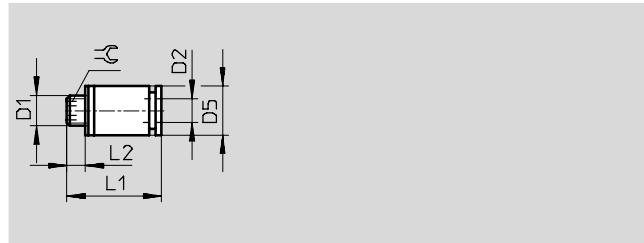

R 螺纹

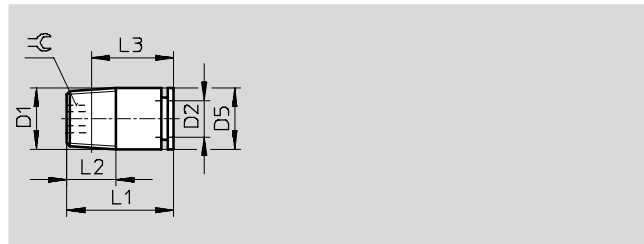

G 螺纹

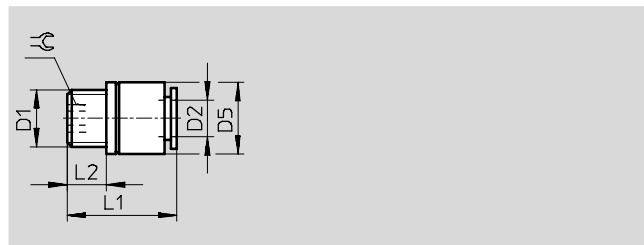

尺寸和订货数据											
接口	公称通径	气管外径	D5	L1	L2	L3	≈C	每件重量	订货号	型号	PU*
D1	[mm]	D2	∅					[g]			
<b>公制螺纹, 带密封圈</b>											
M3	1.6	3	8	16.5	3.3	-	1.5	3	153312	QSM-M3-3-I	10
	1.5	4	8	16.5	3.3	-	1.5	3	153314	QSM-M3-4-I	10
M5	1.9	3	8	16.7	3.5	-	2	3	153313	QSM-M5-3-I	10
	2.5	4	8	16.7	3.5	-	2.5	4	153315	QSM-M5-4-I	10
	2.6	6	9.8	18.3	3.5	-	2.5	5	153317	QSM-M5-6-I	10
M7	2.3	4	9.8	18.9	5.5	-	3	4	153319	QSM-M7-4-I	10
	2.9	6	9.8	20.9	5.5	-	4	5	153321	QSM-M7-6-I	10
<b>R 螺纹</b>											
R1/8	3.1	4	10	16	8	11.5	3	6	153316	QSM-1/8-4-I	10
	4.1	6	10	18	8	13.5	4	6	153318	QSM-1/8-6-I	10
<b>G 螺纹, 带密封圈</b>											
G1/8	3.1	4	13	16.4	5.1	-	3	8.9	186266	QSM-G1/8-4-I	10
	4.1	6	13	18.4	5.1	-	4	9.5	186267	QSM-G1/8-6-I	10

\* 包装单位数量

# 快插/螺纹接头 QSM, mini

技术参数



## 快插/螺纹接头 QSM-...-I-R

外螺纹  
带内六角

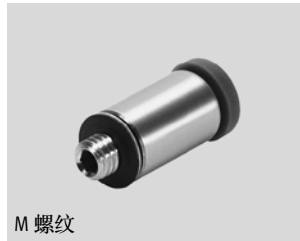

M 螺纹

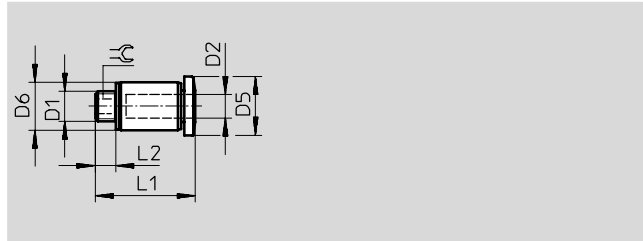

尺寸和订货数据											
接口	公称通径	气管外径	D5	D6	L1	L2	≈	每件重量	订货号	型号	PU*
D1	[mm]	D2	∅	∅				[g]			
公制螺纹, 带密封圈											
M3	1.4	3	5.5	6.0	13.25	2.5	1.5	1.0	132914	QSM-M3-3-I-R-100	100
	1.5	4	8.0	7.8	15.7	2.5	1.5	2.2	132915	QSM-M3-4-I-R-100	100
M5	1.9	3	8.0	7.8	16.2	3.0	2.0	3.2	132916	QSM-M5-3-I-R-100	100
	2.5	4	8.0	7.8	16.2	3.0	2.5	2.9	132917	QSM-M5-4-I-R-100	100
	2.6	6	9.8	9.8	17.8	3.0	2.5	4.1	132918	QSM-M5-6-I-R-100	100
M7	2.9	6	9.8	9.8	20.9	5.5	4.0	5.0	132919	QSM-M7-6-I-R-100	100

\* 包装单位数量

# 快插/螺纹接头 QSM, mini

技术参数



## 快插/螺纹接头 QSMF

内螺纹  
带外六角

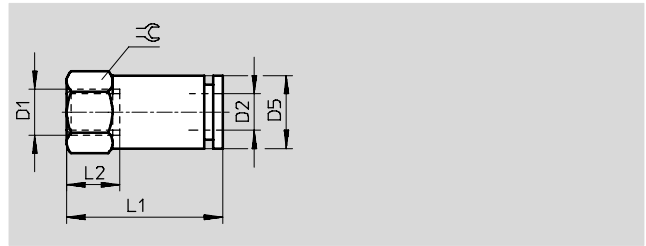

尺寸和订货数据										
接口	公称通径	气管外径	D5	L1	L2	≈	每件重量	订货号	型号	PU*
D1	[mm]	D2	∅				[g]			
公制螺纹, 带密封圈										
M3	1.3	3	5.5	13.9	4.4	5.5	1.6	153308	QSMF-M3-3	10
	2.1	4	8	16	4.5	8	4.1	153310	QSMF-M3-4	10
M5	1.9	3	8	15.5	4.5	8	4.3	153309	QSMF-M5-3	10
	1.8	4	8	18.2	4.5	8	4.5	153311	QSMF-M5-4	10

\* 包装单位数量

## 快插/螺纹接头 QSMP

外螺纹  
带内六角

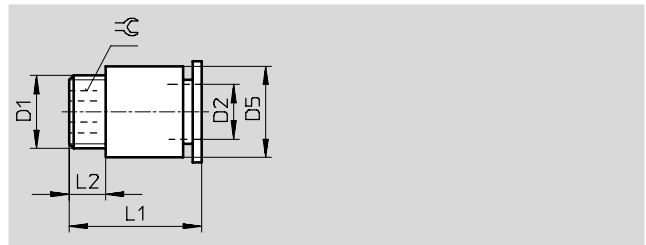

尺寸和订货数据										
接口	公称通径	气管外径	D5	L1	L2	≈	每件重量	订货号	型号	PU*
D1	[mm]	D2	∅				[g]			
公制螺纹, 带密封圈										
M6x0.75	2.5	4	8	14.5	3.5	2.5	3	153320	QSMP-M6-4	10
M8x0.75	4	6	10	15	4	4	4	153322	QSMP-M8-6	10

\* 包装单位数量

# 快插/螺纹接头 QSM, mini

技术参数

FESTO

## 快插接头 QSM

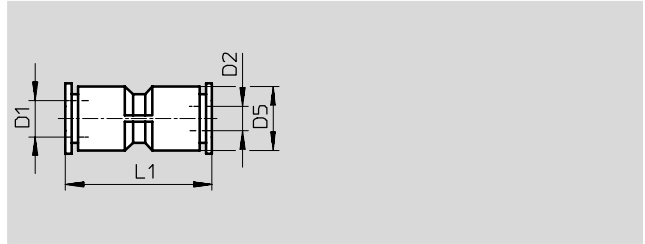

尺寸和订货数据								
气管外径	公称通径	气管 外径	D5	L1	每件重量	订货号	型号	PU*
D1	[mm]	D2	∅		[g]			
3	1.9	3	6	20	1.5	153323	QSM-3	10
						130757	QSM-3-100	100
4	2.6	4	8	23.5	2	153324	QSM-4	10
						130758	QSM-4-100	100
6	3.7	6	10.5	25	4	153325	QSM-6	10
						130759	QSM-6-100	100
变径								
4	1.7	3	8	23.5	3	153326	QSM-4-3	10
						130760	QSM-4-3-100	100
6	2.7	4	10.5	25	4	153327	QSM-6-4	10
						130761	QSM-6-4-100	100

\* 包装单位数量

## 穿板式快插接头 QSMS

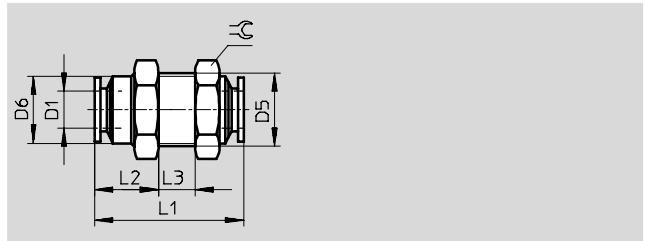

尺寸和订货数据											
气管外径	公称通径	D5	D6	L1	L2	L3	∅	每件重量	订货号	型号	PU*
D1	[mm]		∅					[g]			
3	1.7	M8x0.75	7	19.5	7	7.5	10	3	153375	QSMS-3	10
4	2.2	M10x1	9	24	9.5	7.5	12	6	153376	QSMS-4	10
									130780	QSMS-4-100	100
6	3.7	M12x1	11	25	11	6	14	9	153377	QSMS-6	10
									130781	QSMS-6-100	100

\* 包装单位数量

# 快插/螺纹接头 QSM, mini

技术参数



## 快插堵头 QSMC

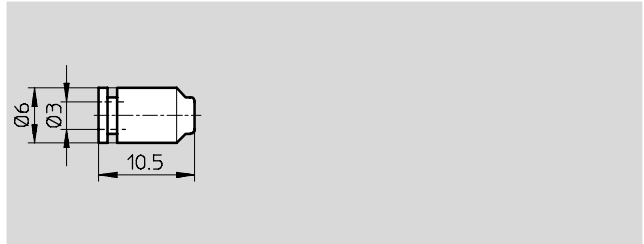

订货数据				
气管外径	每件重量 [g]	订货号	型号	PU*
3	0.5	153381	QSMC-3	10

\* 包装单位数量

## 快插接头 QSM-...H

带插入式轴套

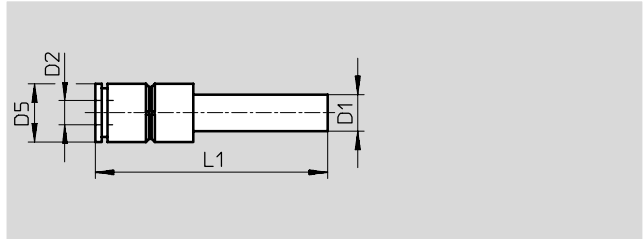

尺寸和订货数据								
插入式轴套 Ø	公称通径 [mm]	气管外径 D2	D5 Ø	L1	每件重量 [g]	订货号	型号	PU*
4	1.7	3	6	27	0.8	153328	QSM-4H-3	10
						130762	QSM-4H-3-100	100
6	2.1	4	9	32.6	1.6	153329	QSM-6H-4	10
						130763	QSM-6H-4-100	100

\* 包装单位数量

## 堵头 QSMC-...H

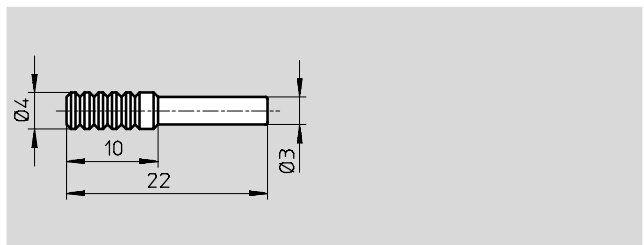

订货数据				
插入式轴套 Ø	每件重量 [g]	订货号	型号	PU*
3	0.5	153382	QSMC-3H	10

\* 包装单位数量

# 快插/螺纹接头 QSM, mini

技术参数

FESTO

## L形快插/螺纹接头 QSML

360°可旋转  
外螺纹  
带外六角

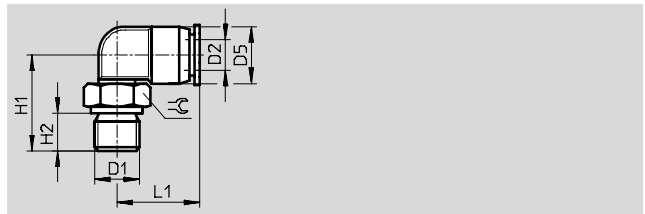
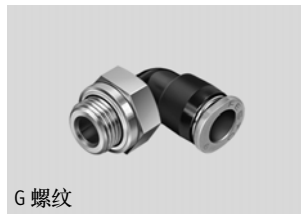
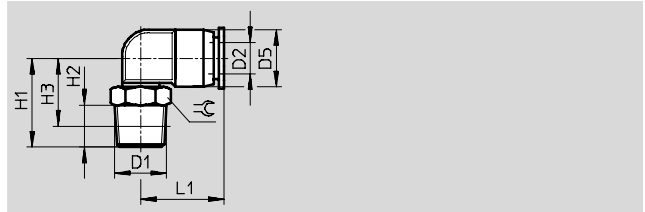
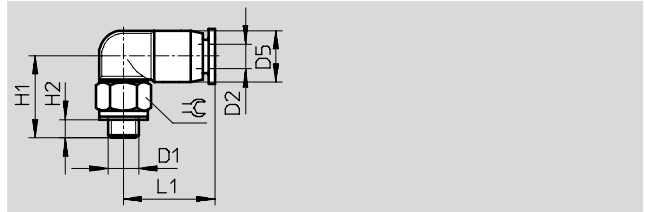

尺寸和订货数据													
接口	公称通径	气管外径	D5 ∅	H1	H2	H3	L1	≈	每件重量	订货号	型号	PU*	
D1	[mm]	D2							[g]				
<b>公制螺纹, 带密封圈</b>													
M3	0.8	3	6	12.8	3.3	-	11	5.5	1.5	153330	QSML-M3-3	10	
	1.3	4	8	14.8	3.3	-	15.7	8	3.1	130768	QSML-M3-3-100	100	
										153332	QSML-M3-4	10	
130769	QSML-M3-4-100	100											
M5	1.5	3	6	14	3.5	-	11	8	2.8	153331	QSML-M5-3	10	
	1.7	4	8	14	3.5	-	15.7	8	3.5	130770	QSML-M5-3-100	100	
										153333	QSML-M5-4	10	
	130771	QSML-M5-4-100	100										
	2.1	6	10.5	15	3.5	-	16.3	8	4.1	153335	QSML-M5-6	10	
130772	QSML-M5-6-100	100											
M7	2	4	8	17	5.5	-	15.7	10	5.6	186352	QSML-M7-4	10	
	2.4	6	10.5	19	5.5	-	16.3	10	6.2	130773	QSML-M7-4-100	100	
										186353	QSML-M7-6	10	
130774	QSML-M7-6-100	100											
<b>R 螺纹</b>													
R1/8	2.5	4	8.5	16	8	12	16	10	6	153334	QSML-1/8-4	10	
	3.3	6	11	17	8	13	16.5	10	7	130764	QSML-1/8-4-100	100	
										153336	QSML-1/8-6	10	
130765	QSML-1/8-6-100	100											
<b>G 螺纹, 带密封圈</b>													
G1/8	2.5	4	8	16.5	5.1	-	15.7	13	9	186268	QSML-G1/8-4	10	
	3.3	6	10.5	17.5	5.1	-	16.3	13	9.7	132897	QSML-G1/8-4-100	新品 100	
186269										QSML-G1/8-6	10		

\* 包装单位数量



# 快插/螺纹接头 QSM, mini

技术参数

FESTO

## 加长L形快插/螺纹接头 QSMLL

360°可旋转

外螺纹

带外六角

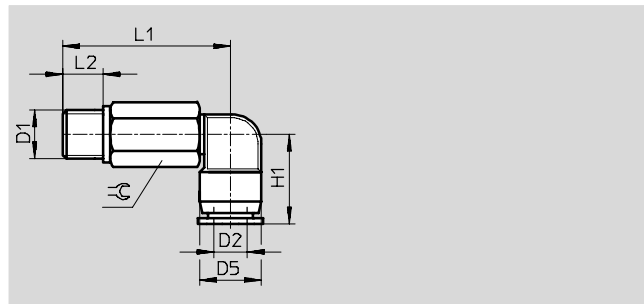
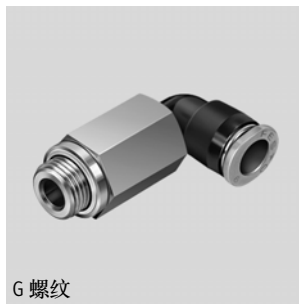
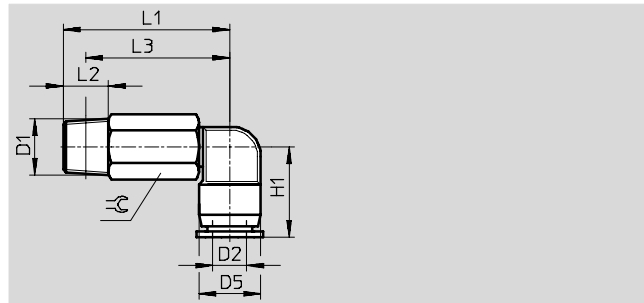
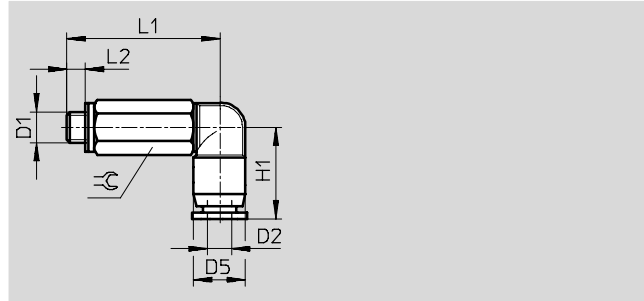

尺寸和订货数据												
接口	公称通径	气管外径	D5 Ø	H1	L1	L2	L3	≈	每件重量	订货号	型号	PU*
D1	[mm]	D2							[g]			
公制螺纹, 带密封圈												
M3	0.9	3	6	11	19.5	3.3	-	5.5	2.8	153337	QSMLL-M3-3	10
	1.1	4	8	15.7	23.5	3.3	-	8	6.8	153338	QSMLL-M3-4	10
M5	1.6	3	6	11	25.5	3.5	-	8	7.6	130838	QSMLL-M5-3	10
	2	4	8	15.7	25.5	3.5	-	8	8.3	153339	QSMLL-M5-4	10
	2	6	10.5	16.3	26.5	3.5	-	8	9	153341	QSMLL-M5-6	10
M7	2	4	8	15.7	29.5	5.5	-	10	14	186354	QSMLL-M7-4	10
	2.4	6	10.5	16.3	31.5	5.5	-	10	14	186355	QSMLL-M7-6	10
R 螺纹												
R1/8	2.3	4	8.5	15.5	28.5	8	22	10	13	153340	QSMLL-1/8-4	10
	3.1	6	11	16.5	29.5	8	25.5	10	14	153342	QSMLL-1/8-6	10
G 螺纹, 带密封圈												
G1/8	2.3	4	8	15.7	29	5.1	-	13	23	186270	QSMLL-G1/8-4	10
	3.1	6	10.5	16.3	30	5.1	-	13	23	186271	QSMLL-G1/8-6	10

\* 包装单位数量

# 快插/螺纹接头 QSM, mini

技术参数

FESTO

## L形快插/螺纹接头 QSMLV-...-I

360°可旋转

外螺纹

带内六角



M 螺纹

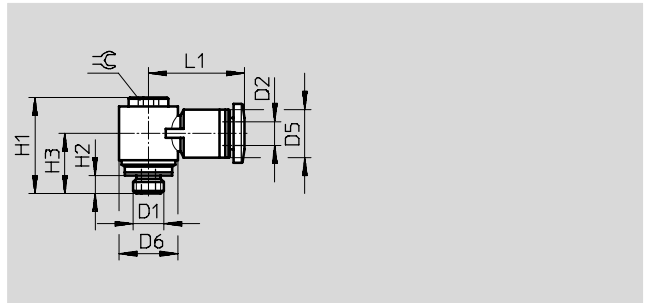

尺寸和订货数据													
接口	公称通径	气管外径	D5	D6	H1	H2	H3	L1	≅	每件重量	订货号	型号	PU*
D1	[mm]	D2	∅	∅						[g]			
公制螺纹, 带密封圈													
M5	1.7	3	8	9.8	16.5	3.5	10.5	16	3	5.1	130830	QSMLV-M5-3-I	10
	1.8	4	8	9.8	16.5	3.5	10.5	16	3	5.0	130831	QSMLV-M5-4-I	10
M7	1.9	4	8	9.8	18.5	5.5	12.5	16	3	5.6	130832	QSMLV-M7-4-I	10
	1.8	6	10.5	9.8	18.5	5.5	12.5	17.8	3	6.2	130833	QSMLV-M7-6-I	10

\* 包装单位数量

## 加长L形快插/螺纹接头 QSMLLV-...-I

360°可旋转

外螺纹

带内六角



M 螺纹

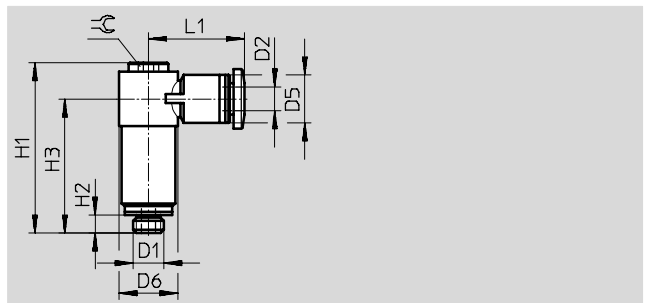

尺寸和订货数据													
接口	公称通径	气管外径	D5	D6	H1	H2	H3	L1	≅	每件重量	订货号	型号	PU*
D1	[mm]	D2	∅	∅						[g]			
公制螺纹, 带密封圈													
M5	1.6	3	8	9.8	28.3	3.5	22.3	16	3	10.9	130834	QSMLLV-M5-3-I	10
	1.8	4	8	9.8	28.3	3.5	22.3	16	3	10.9	130835	QSMLLV-M5-4-I	10
M7	1.9	4	8	9.8	30.3	5.5	24.3	16	3	11.8	130836	QSMLLV-M7-4-I	10
	1.9	6	10.5	9.8	30.3	5.5	24.3	17.8	3	12.4	130837	QSMLLV-M7-6-I	10

\* 包装单位数量

# 快插/螺纹接头 QSM, mini

技术参数



## L形快插接头QSML

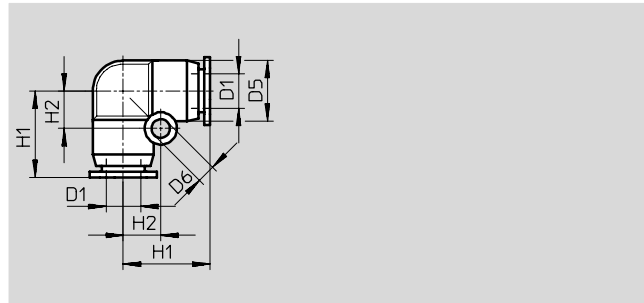

### 尺寸和订货数据

气管外径 D1	公称通径 [mm]	D5 ∅	D6 ∅	H1	H2	每件重量 [g]	订货号	型号	PU*
3	1.7	6	3.2	11	4.5	1.5	153343	QSML-3	10
4	2.5	8	3.2	13.5	5.5	2	153344	QSML-4	10
							130766	QSML-4-100	100
6	3.4	10.5	3.2	15.5	6.5	4	153345	QSML-6	10
							130767	QSML-6-100	100

\* 包装单位数量

## L形快插接头QSML...H

带插入式轴套

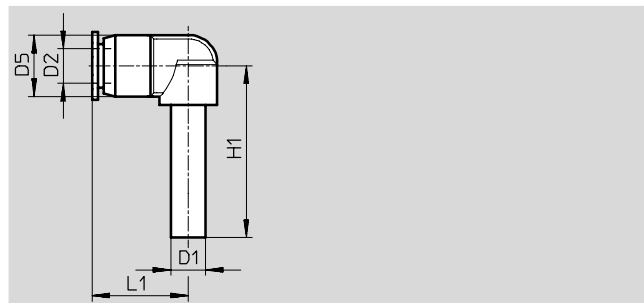

### 尺寸和订货数据

插入式轴套 套∅ D1	公称通径 [mm]	气管外径 D2	D5 ∅	H1	L1	每件重量 [g]	订货号	型号	PU*
3	1.2	3	9	24	14.7	1.7	153346	QSML-3H	10
4	1.9	4	9	25	14.7	1.7	153347	QSML-4H	10
6	3.2	6	10.5	26.5	17.3	2.4	153348	QSML-6H	10
变径									
4	1.7	3	9	25	14.7	1.7	153349	QSML-4H-3	10
6	1.9	4	9	26	14.7	1.9	153350	QSML-6H-4	10

\* 包装单位数量

# 快插/螺纹接头 QSM, mini

技术参数



## T形快插/螺纹接头 QSMT

360°可旋转

外螺纹

带外六角



M 螺纹

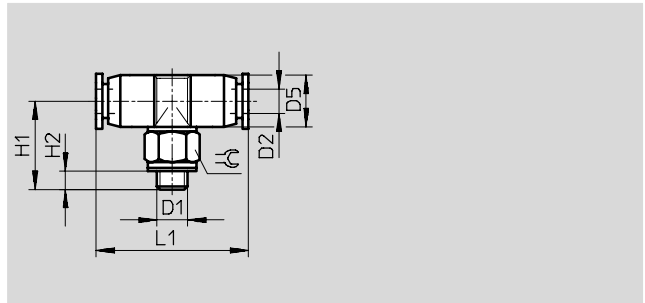

R 螺纹

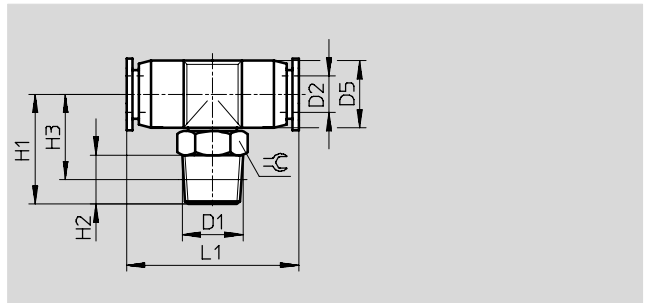

G 螺纹

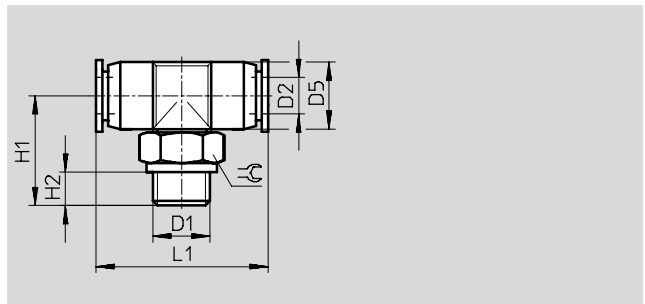

尺寸和订货数据													
接口	公称通径	气管外径	D5	H1	H2	H3	L1	≈C	每件重量	订货号	型号	PU*	
D1	[mm]	D2	∅						[g]				
公制螺纹, 带密封圈													
M3	0.9	3	6	12.8	3.3	-	22	5.5	2	153351	QSMT-M3-3	10	
	1.3	4	8	15.8	3.3	-	26.2	8	4	153353	QSMT-M3-4	10	
M5	1.6	3	6	14	3.5	-	22	8	3.3	153352	QSMT-M5-3	10	
	2.2	4	8	15	3.5	-	26.2	8	4.4	130784	QSMT-M5-4-100	100	
										153356	QSMT-M5-6	10	
2.1	6	10.5	16	3.5	-	28.4	8	5.6	130785	QSMT-M5-6-100	100		
R 螺纹													
R1/8	2.4	4	8.5	17	8	13	27	10	7	153355	QSMT-1/8-4	10	
	3.3	6	11	18	8	14	30	10	8	153357	QSMT-1/8-6	10	
G 螺纹, 带密封圈													
G1/8	2.4	4	8	17.5	5.1	-	26.2	13	10	186272	QSMT-G1/8-4	10	
	3.3	6	10.5	18.5	5.1	-	28.4	13	12	186273	QSMT-G1/8-6	10	

\* 包装单位数量

# 快插/螺纹接头 QSM, mini

技术参数

FESTO

## T形快插/螺纹接头 QSMTL

360° 可旋转

外螺纹

带外六角



M 螺纹

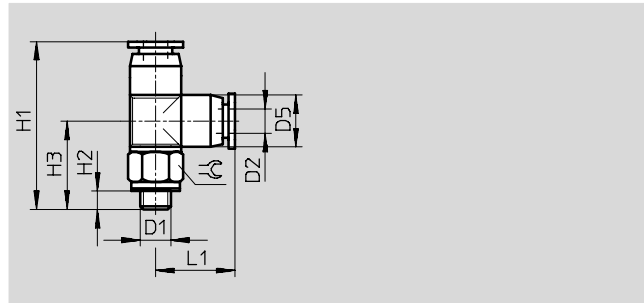

R 螺纹

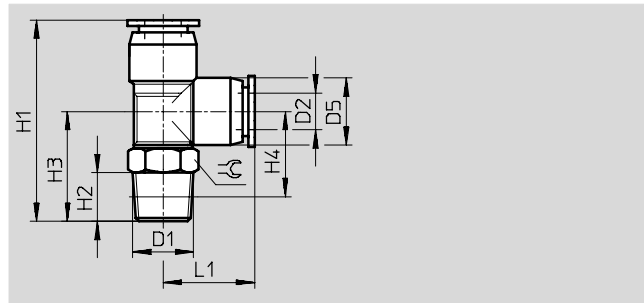

G 螺纹

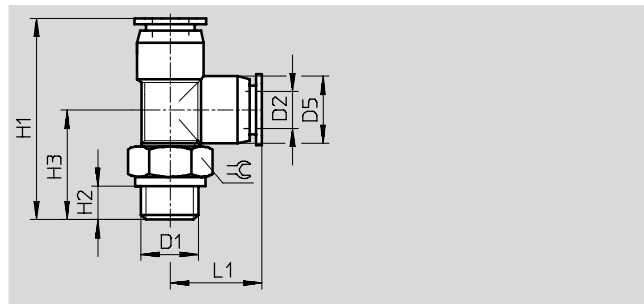

### 尺寸和订货数据

接口	公称通径	气管外径	D5 ∅	H1	H2	H3	H4	L1	≈C	每件重量	订货号	型号	PU*
D1	[mm]	D2								[g]			
<b>公制螺纹, 带密封圈</b>													
M3	0.9	3	6	23.8	3.3	12.8	-	11	5.5	2	153358	QSMTL-M3-3	10
	1.1	4	8	29.5	3.3	15.8	-	13.7	8	4	153360	QSMTL-M3-4	10
M5	1.7	3	6	25	3.5	14	-	11	8	3.3	153359	QSMTL-M5-3	10
	1.6	4	8	28.7	3.5	15	-	13.7	8	4.4	153361	QSMTL-M5-4	10
	1.7	6	10.5	31.3	3.5	16	-	15.3	8	5.7	153363	QSMTL-M5-6	10
<b>R 螺纹</b>													
R1/8	2.4	4	8.5	30	8	17	13	13	10	7	153362	QSMTL-1/8-4	10
	3.3	6	10.5	33	8	18	14	15	10	8.5	153364	QSMTL-1/8-6	10
<b>G 螺纹, 带密封圈</b>													
G1/8	2.4	4	8	31.2	5.1	17.5	-	13.7	13	10	186274	QSMTL-G1/8-4	10
	3.3	6	10.5	33.8	5.1	18.5	-	15.3	13	12	186275	QSMTL-G1/8-6	10

\* 包装单位数量

# 快插/螺纹接头 QSM, mini

技术参数

FESTO

## T形快插接头QSMT

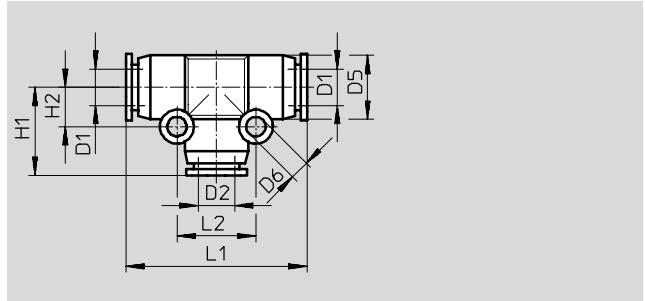

尺寸和订货数据												
气管外径	公称通径	气管外径	D5 Ø	D6 Ø	H1	H2	L1	L2	每件重量	订货号	型号	PU*
D1	[mm]	D2							[g]			
3	1.6	3	6	3.2	11	4.5	22	9	2	153365	QSMT-3	10
4	2.4	4	8	3.2	13.5	5.5	27	11	2	153366	QSMT-4	10
										130782	QSMT-4-100	100
6	3.4	6	10.5	3.2	15.5	6.5	31	13	4	153367	QSMT-6	10
										130783	QSMT-6-100	100
变径												
4	1.7	3	8	3.2	13	5.5	27	11	3.5	153368	QSMT-4-3	10
6	2.6	4	10.5	3.2	15	6.5	30	13	4	153369	QSMT-6-4	10

\* 包装单位数量

# 快插/螺纹接头 QSM, mini

技术参数



## X形快插接头QSMX

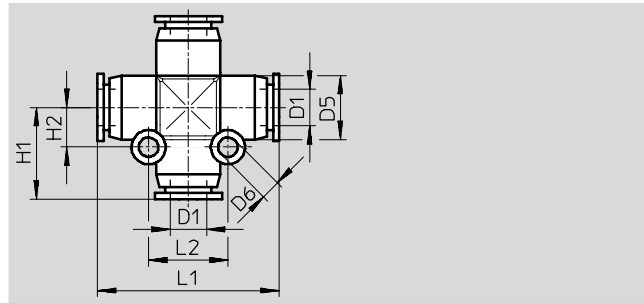

### 尺寸和订货数据

气管外径 D1	公称通径 [mm]	D5 ∅	D6 ∅	H1	H2	L1	L2	每件重量 [g]	订货号	型号	PU*
3	1.7	8	3.2	13.5	5.5	27	11	4	153378	QSMX-3	10
4	2.5	8	3.2	13.5	5.5	27	11	4	153379	QSMX-4	10
6	3.3	10.5	3.2	15.5	6.5	31	13	5	153380	QSMX-6	10

\* 包装单位数量

## Y形快插接头QSMY

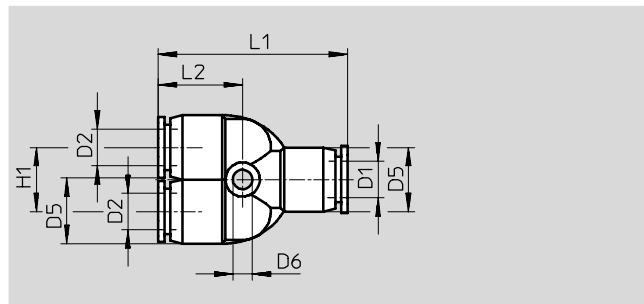

### 尺寸和订货数据

气管外径 D1	公称通径 [mm]	气管外径 D2	D5 ∅	D6 ∅	H1	L1	L2	每件重量 [g]	订货号	型号	PU*
3	1.6	3	8	3.2	8	28.5	13	3	153370	QSMY-3	10
4	1.7	4	8	3.2	8	29	13	3	153371	QSMY-4	10
									130786	QSMY-4-100	100
6	2.9	6	10.5	3.2	10.5	31.5	14.5	5.5	153372	QSMY-6	10
									130787	QSMY-6-100	100
变径											
4	1.6	3	8	3.2	8	28.5	13	3	153373	QSMY-4-3	10
6	2.8	4	10.5	3.2	10.5	31.5	14	5	153374	QSMY-6-4	10

\* 包装单位数量

# 快插/螺纹接头 QS

技术参数

FESTO

螺纹/快插接头 QS

外螺纹  
带外六角

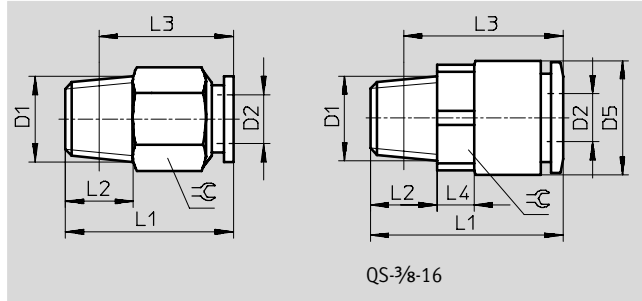

尺寸和订货数据												
接口	公称通径	气管外径	D5	L1	L2	L3	L4	≈C	每件重量	订货号	型号	PU*
D1	[mm]	D2							[g]			
<b>R 螺纹</b>												
R1/8	2.6	4	-	21	8	17	-	10	8.5	153001	QS-1/8-4	10
										130674	QS-1/8-4-100	100
	4	6	-	22.5	8	18.5	-	12	9	153002	QS-1/8-6	10
										130675	QS-1/8-6-100	100
	5	8	-	28	8	24	-	14	15	153004	QS-1/8-8	10
										130676	QS-1/8-8-50	50
	5.4	10	-	30.3	8	26.3	-	17	22.5	190643	QS-1/8-10	10
R1/4	2.6	4	-	21	11	15	-	14	16	190644	QS-1/4-4	10
	4	6	-	24.5	11	18.5	-	14	17	153003	QS-1/4-6	10
										130677	QS-1/4-6-100	100
	5	8	-	26.5	11	20.5	-	14	15	153005	QS-1/4-8	10
										130678	QS-1/4-8-50	50
	6.7	10	-	30	11	24	-	17	20	153007	QS-1/4-10	10
										130679	QS-1/4-10-50	50
	8.7	12	-	36	11	30	-	21	43.7	164980	QS-1/4-12	10
										130680	QS-1/4-12-20	20
R3/8	4	6	-	23.5	12	17.1	-	17	27	190645	QS-3/8-6	10
	5	8	-	24	12	17.5	-	17	23	153006	QS-3/8-8	10
										130681	QS-3/8-8-50	50
	6.7	10	-	29.5	12	23	-	17	26	153008	QS-3/8-10	10
										130682	QS-3/8-10-50	50
	8.7	12	-	32	12	25.5	-	21	35.5	153009	QS-3/8-12	10
										130683	QS-3/8-12-20	20
	10.3	16	23.8	41.9	12	35.4	10	22	59.5	164957	QS-3/8-16	1
R1/2	6.7	10	-	30.3	15	22.1	-	21	49	190646	QS-1/2-10	1
	8.7	12	-	34	15	26	-	21	49.5	153010	QS-1/2-12	1
										130684	QS-1/2-12-20	20
	12	16	-	41.5	15	33.5	-	24	67	153011	QS-1/2-16	1
										130685	QS-1/2-16-20	20

\* 包装单位数量



# 快插/螺纹接头 QS

技术参数

螺纹/快插接头 QS

外螺纹

带外六角



G 螺纹

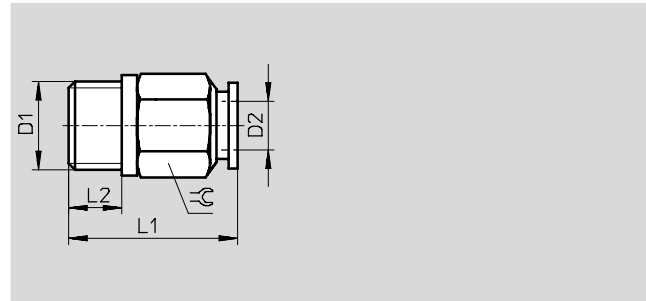

尺寸和订货数据									
接口	公称通径	气管外径	L1	L2	≈C	每件重量	订货号	型号	PU*
D1	[mm]	D2				[g]			
<b>G 螺纹, 带密封圈</b>									
G <sup>1</sup> / <sub>8</sub>	2.6	4	20.4	5.1	13	10	186095	QS-G <sup>1</sup> / <sub>8</sub> -4	10
							132036	QS-G <sup>1</sup> / <sub>8</sub> -4-100	· 新产品 100
	4	6	21.5	5.1	13	9.1	186096	QS-G <sup>1</sup> / <sub>8</sub> -6	10
							132037	QS-G <sup>1</sup> / <sub>8</sub> -6-100	· 新产品 100
	5	8	26.7	5.1	14	14	186098	QS-G <sup>1</sup> / <sub>8</sub> -8	10
							132038	QS-G <sup>1</sup> / <sub>8</sub> -8-50	· 新产品 50
G <sup>1</sup> / <sub>4</sub>	4	6	22	5.6	17	18	186097	QS-G <sup>1</sup> / <sub>4</sub> -6	10
							132039	QS-G <sup>1</sup> / <sub>4</sub> -6-100	· 新产品 100
	5	8	22.7	5.6	17	16	186099	QS-G <sup>1</sup> / <sub>4</sub> -8	10
							132040	QS-G <sup>1</sup> / <sub>4</sub> -8-50	· 新产品 50
	6.7	10	29.7	5.6	17	22	186101	QS-G <sup>1</sup> / <sub>4</sub> -10	10
							132041	QS-G <sup>1</sup> / <sub>4</sub> -10-50	· 新产品 50
G <sup>3</sup> / <sub>8</sub>	6.3	12	34.9	5.6	21	51	186350	QS-G <sup>3</sup> / <sub>8</sub> -12	10
							132042	QS-G <sup>3</sup> / <sub>8</sub> -12-20	· 新产品 20
	5	8	22.4	6.6	19	24	186100	QS-G <sup>3</sup> / <sub>8</sub> -8	10
							132043	QS-G <sup>3</sup> / <sub>8</sub> -8-50	· 新产品 50
	6.7	10	26.2	6.6	19	25	186102	QS-G <sup>3</sup> / <sub>8</sub> -10	10
							132044	QS-G <sup>3</sup> / <sub>8</sub> -10-50	· 新产品 50
G <sup>3</sup> / <sub>8</sub>	8.7	12	32.3	6.6	21	38	186103	QS-G <sup>3</sup> / <sub>8</sub> -12	10
							132045	QS-G <sup>3</sup> / <sub>8</sub> -12-20	· 新产品 20
	10.3	16	38.3	6.6	22	49	186347	QS-G <sup>3</sup> / <sub>8</sub> -16	1
G <sup>1</sup> / <sub>2</sub>	8.7	12	28.8	7.6	24	46	186104	QS-G <sup>1</sup> / <sub>2</sub> -12	1
							132046	QS-G <sup>1</sup> / <sub>2</sub> -12-20	· 新产品 20
	12	16	36.3	7.6	24	53	186105	QS-G <sup>1</sup> / <sub>2</sub> -16	1
							132047	QS-G <sup>1</sup> / <sub>2</sub> -16-20	· 新产品 20

\* 包装单位数量

# 快插/螺纹接头 QS

技术参数

FESTO

螺纹/快插接头 QS...-I  
外螺纹  
带内六角



R 螺纹

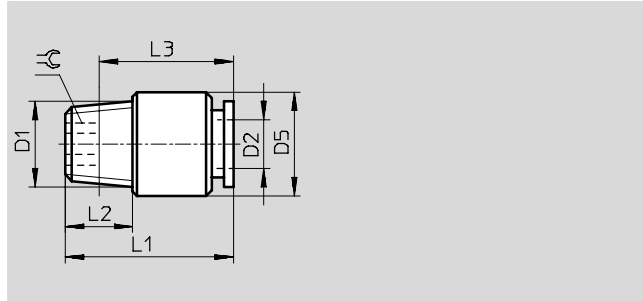

G 螺纹

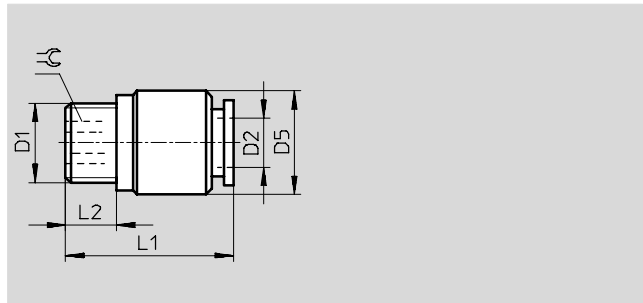

尺寸和订货数据											
接口	公称通径	气管外径	D5	L1	L2	L3	≈	每件重量	订货号	型号	PU*
D1	[mm]	D2	∅					[g]			
<b>R 螺纹</b>											
R <sup>1</sup> / <sub>8</sub>	2.1	4	9.5	21	8	17	2.5	8	153012	QS- <sup>1</sup> / <sub>8</sub> -4-I	10
	3.7	6	12	22.5	8	18.5	4	8	153013	QS- <sup>1</sup> / <sub>8</sub> -6-I	10
	4.7	8	13.7	28	8	24	5	14	153015	QS- <sup>1</sup> / <sub>8</sub> -8-I	10
	5	10	17.7	30.3	8	26.3	5	25	190647	QS- <sup>1</sup> / <sub>8</sub> -10-I	10
R <sup>1</sup> / <sub>4</sub>	3.7	6	14	22.5	11	16.5	4	14	153014	QS- <sup>1</sup> / <sub>4</sub> -6-I	10
	5	8	14	26.5	11	20.5	6	14.5	153016	QS- <sup>1</sup> / <sub>4</sub> -8-I	10
	5	10	17.7	30	11	24	7	22	153018	QS- <sup>1</sup> / <sub>4</sub> -10-I	10
	6.8	12	20.8	35.9	11	29.9	6	40	190649	QS- <sup>1</sup> / <sub>4</sub> -12-I	10
R <sup>3</sup> / <sub>8</sub>	5	8	17	24	12	17.5	6	22	153017	QS- <sup>3</sup> / <sub>8</sub> -8-I	10
	5	10	18	29.5	12	23	6	27	153019	QS- <sup>3</sup> / <sub>8</sub> -10-I	10
	7.1	12	21	32	12	25.5	8	33.5	153020	QS- <sup>3</sup> / <sub>8</sub> -12-I	10
R <sup>1</sup> / <sub>2</sub>	5	10	20.8	30.3	15	22.1	6	48	190648	QS- <sup>1</sup> / <sub>2</sub> -10-I	1
	7.1	12	21	34	15	26	8	48	153021	QS- <sup>1</sup> / <sub>2</sub> -12-I	1
<b>G 螺纹, 带密封圈</b>											
G <sup>1</sup> / <sub>8</sub>	2.1	4	13	20.4	5.1	-	2.5	12	186106	QS-G <sup>1</sup> / <sub>8</sub> -4-I	10
	3.7	6	13	22.5	5.1	-	4	11	186107	QS-G <sup>1</sup> / <sub>8</sub> -6-I	10
	4.7	8	13.8	26.7	5.1	-	5	13	186109	QS-G <sup>1</sup> / <sub>8</sub> -8-I	10
G <sup>1</sup> / <sub>4</sub>	3.7	6	17	21	5.6	-	4	18	186108	QS-G <sup>1</sup> / <sub>4</sub> -6-I	10
	5	8	17	25.2	5.6	-	6	22	186110	QS-G <sup>1</sup> / <sub>4</sub> -8-I	10
	6.7	10	17	29.7	5.6	-	7	22	186112	QS-G <sup>1</sup> / <sub>4</sub> -10-I	10
G <sup>3</sup> / <sub>8</sub>	5	8	19	24.7	6.6	-	6	29	186111	QS-G <sup>3</sup> / <sub>8</sub> -8-I	10
	6.7	10	19	27.2	6.6	-	7	28	186113	QS-G <sup>3</sup> / <sub>8</sub> -10-I	10
	7.1	12	20.8	32.3	6.6	-	8	38	186114	QS-G <sup>3</sup> / <sub>8</sub> -12-I	10
G <sup>1</sup> / <sub>2</sub>	7.1	12	24	28.8	7.6	-	8	50	186115	QS-G <sup>1</sup> / <sub>2</sub> -12-I	1

\* 包装单位数量

# 快插/螺纹接头 QS

技术参数

FESTO

螺纹/快插接头 QSF  
内螺纹  
带外六角



G 螺纹

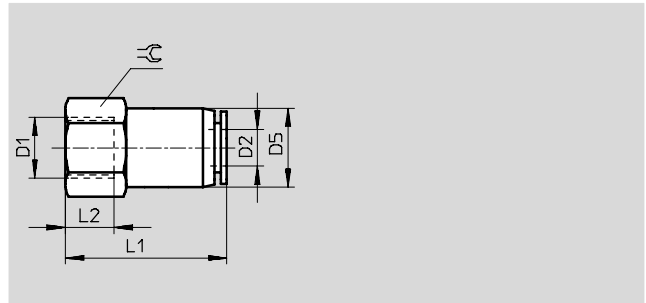

尺寸和订货数据										
接口	公称通径	气管外径	D5 ∅	L1	L2	≈C	每件重量	订货号	型号	PU*
D1	[mm]	D2					[g]			
<b>G 螺纹, 带密封圈</b>										
G <sup>1</sup> / <sub>8</sub>	2.6	4	11	24.4	7	14	15	153022	QSF- <sup>1</sup> / <sub>8</sub> -4-B	10
								130709	QSF- <sup>1</sup> / <sub>8</sub> -4-B-100	100
	4	6	13	26.5	7	14	18	153023	QSF- <sup>1</sup> / <sub>8</sub> -6-B	10
								130710	QSF- <sup>1</sup> / <sub>8</sub> -6-B-100	100
	5.8	8	14.5	28	7	14	19	153025	QSF- <sup>1</sup> / <sub>8</sub> -8-B	10
								130711	QSF- <sup>1</sup> / <sub>8</sub> -8-B-50	50
G <sup>1</sup> / <sub>4</sub>	2.8	4	14	27.4	9	17	23	190650	QSF- <sup>1</sup> / <sub>4</sub> -4-B	10
	4	6	13	29.5	9	17	24	153024	QSF- <sup>1</sup> / <sub>4</sub> -6-B	10
								130712	QSF- <sup>1</sup> / <sub>4</sub> -6-B-100	100
	5.8	8	15	31	9	17	27	153026	QSF- <sup>1</sup> / <sub>4</sub> -8-B	10
								130713	QSF- <sup>1</sup> / <sub>4</sub> -8-B-50	50
	7.4	10	17.5	33.7	9	17	32	153028	QSF- <sup>1</sup> / <sub>4</sub> -10-B	10
								130714	QSF- <sup>1</sup> / <sub>4</sub> -10-B-50	50
G <sup>3</sup> / <sub>8</sub>	7.2	12	20.8	35.8	9	21	56	190651	QSF- <sup>1</sup> / <sub>4</sub> -12-B	10
	4.1	6	13	30.5	11	21	31	190652	QSF- <sup>3</sup> / <sub>8</sub> -6-B	10
	5.8	8	15.5	32	11	21	35	153027	QSF- <sup>3</sup> / <sub>8</sub> -8-B	10
								130715	QSF- <sup>3</sup> / <sub>8</sub> -8-B-50	50
	7.4	10	17.5	34.7	11	21	40	153029	QSF- <sup>3</sup> / <sub>8</sub> -10-B	10
								130716	QSF- <sup>3</sup> / <sub>8</sub> -10-B-50	50
G <sup>1</sup> / <sub>2</sub>	9.5	12	20.8	36.8	11	21	50	153030	QSF- <sup>3</sup> / <sub>8</sub> -12-B	10
								130717	QSF- <sup>3</sup> / <sub>8</sub> -12-B-20	20
	10.6	16	25	43.8	14	25	59	190653	QSF- <sup>1</sup> / <sub>2</sub> -12-B	1
								190654	QSF- <sup>1</sup> / <sub>2</sub> -16-B	1

\* 包装单位数量

# 快插/螺纹接头 QS

技术参数

FESTO

## 快插接头 QS

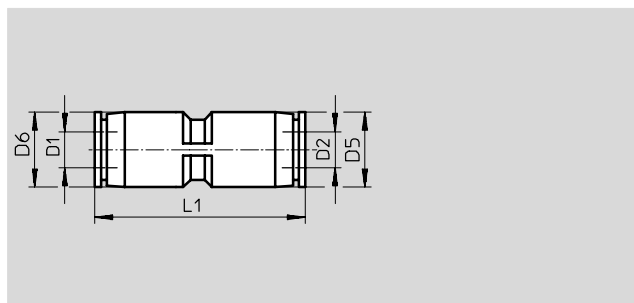

尺寸和订货数据									
气管外径 D1	公称通径 [mm]	气管 外径 D2	D5 ∅	D6	L1	每件重量 [g]	订货号	型号	PU*
4	2.6	4	10	-	31	5	153031	QS-4	10
							130686	QS-4-100	100
6	4	6	12.5	-	35	6.5	153032	QS-6	10
							130687	QS-6-100	100
8	5	8	14.5	-	38	9.5	153033	QS-8	10
							130688	QS-8-50	50
10	6.7	10	17.5	-	44	16	153034	QS-10	10
							130689	QS-10-50	50
12	8.7	12	21	-	48	22	153035	QS-12	10
							130690	QS-12-20	20
16	13.7	16	25	-	50	25	153036	QS-16	1
变径									
6	2.6	4	12.5	12.5	34.4	6.4	153037	QS-6-4	10
							130691	QS-6-4-100	100
8	2.3	4	10.7	14.5	36.6	7.2	130606	QS-8-4	10
							4	6	14.5
						130692			
10	3.7	6	13	17.5	39.8	12	130607	QS-10-6	10
							5	8	17.5
						130693			
12	5.2	8	14.5	21	44	16	130608	QS-12-8	10
							6.7	10	21
						130694			

\* 包装单位数量

# 快插/螺纹接头 QS

技术参数

## 穿板式快插接头QSS

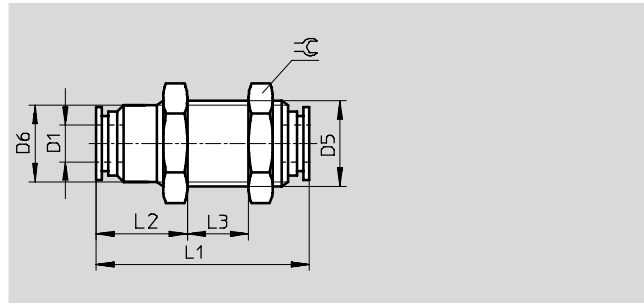

## 穿板式快插接头

QSS...-F

带固定环

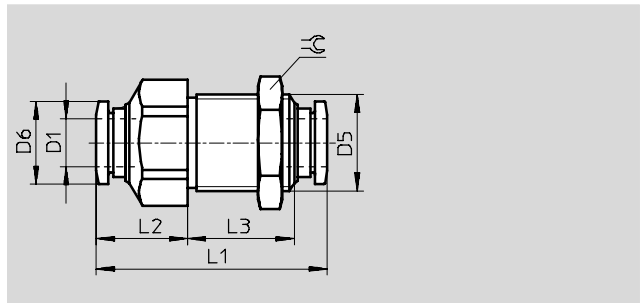

尺寸和订货数据												
气管外径	公称通径	D5	D6	L1	L2	L3	≈G	每件重量	订货号	型号	PU*	
D1	[mm]		∅					[g]				
4	2.6	M12x1	11	31	14.5	7	14	10.5	153157	QSS-4	10	
									130788	QSS-4-100	100	
6	4	M14x1	12.5	35	15	10	17	16	153158	QSS-6	10	
									130789	QSS-6-100	100	
8	5	M16x1	14.5	37.5	18	9	19	19.5	153159	QSS-8	10	
									130790	QSS-8-50	50	
10	6.7	M20x1	18.5	43	18.5	13	24	37.5	153160	QSS-10	10	
									130791	QSS-10-50	50	
12	9.5	M22x1	20.5	47	16.5	18	27	56	153161	QSS-12	10	
									130792	QSS-12-20	20	
带固定环												
4	2.6	M12x1	9.9	33	13	14.7	14	-	193950	QSS-4-F	☉ 新产品	10
6	4.0	M14x1	11.8	34.9	14.4	14.7	17	-	193951	QSS-6-F	☉ 新产品	10
8	5.5	M16x1	13.8	38.4	15.2	17.7	19	40	130642	QSS-8-F		10
10	6.5	M20x1	16.8	47.1	20.3	20.9	24	86	130643	QSS-10-F		10
12	7.5	M22x1	19.8	48.5	18.9	24.1	27	105	130644	QSS-12-F		10

\* 包装单位数量

# 快插/螺纹接头 QS

技术参数

FESTO

穿板式快插接头QSSF  
带内螺纹

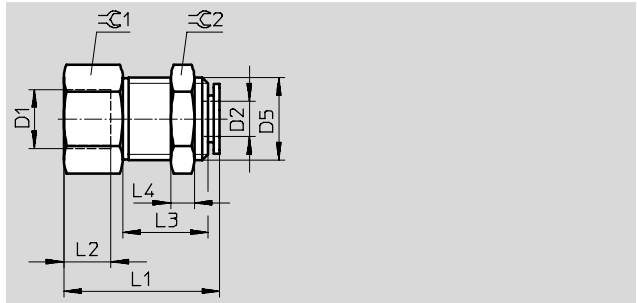

尺寸和订货数据													
接口	公称通径	气管外径	D5 Ø	L1	L2	L3	L4	≈C1	≈C2	每件重量 [g]	订货号	型号	PU*
D1	[mm]	D2											
G <sup>1</sup> / <sub>8</sub>	2.7	4	M12x1	24.5	7	9.9	4	14	14	18	<b>153162</b>	<b>QSSF-1/8-4-B</b>	<b>10</b>
	4.2	6	M14x1	27.1	7	11.9	4	17	17	29	<b>153163</b>	<b>QSSF-1/8-6-B</b>	<b>10</b>
	5.4	8	M16x1	29	7	13.5	4	19	19	38	<b>153165</b>	<b>QSSF-1/8-8-B</b>	<b>10</b>
G <sup>1</sup> / <sub>4</sub>	2.7	4	M12x1	27.5	9	9.9	4	17	14	25	<b>190655</b>	<b>QSSF-1/4-4-B</b>	<b>10</b>
	4	6	M14x1	30.1	9	11.9	4	17	17	29	<b>153164</b>	<b>QSSF-1/4-6-B</b>	<b>10</b>
	5.5	8	M16x1	32	9	13.5	4	19	19	40	<b>153166</b>	<b>QSSF-1/4-8-B</b>	<b>10</b>
	7.2	10	M20x1	34.8	9	14.9	5	24	24	77	<b>153168</b>	<b>QSSF-1/4-10-B</b>	<b>10</b>
G <sup>3</sup> / <sub>8</sub>	4	6	M14x1	31.1	11	11.9	4	19	17	29	<b>190656</b>	<b>QSSF-3/8-6-B</b>	<b>10</b>
	5.3	8	M16x1	33	11	13.5	4	19	19	33	<b>153167</b>	<b>QSSF-3/8-8-B</b>	<b>10</b>
	7.1	10	M20x1	35.8	11	14.9	5	24	24	72	<b>153169</b>	<b>QSSF-3/8-10-B</b>	<b>10</b>
	9.5	12	M22x1	38.8	11	18.4	6	24	27	84	<b>153170</b>	<b>QSSF-3/8-12-B</b>	<b>10</b>
G <sup>1</sup> / <sub>2</sub>	9.4	12	M22x1	41.9	14	18.4	6	24	27	76	<b>153171</b>	<b>QSSF-1/2-12-B</b>	<b>1</b>
	10.6	16	M27x1.5	43.8	14	18.4	10	29	32	145	<b>190657</b>	<b>QSSF-1/2-16-B</b>	<b>1</b>

\* 包装单位数量

# 快插/螺纹接头 QS

技术参数



## 插入式堵头 QSC

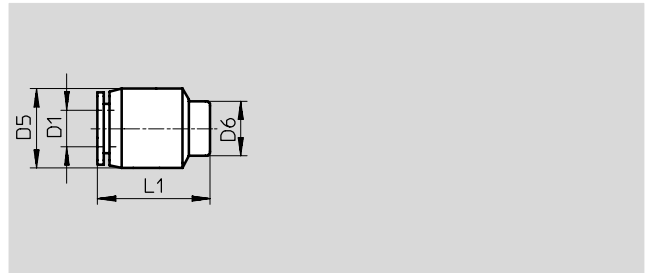

尺寸和订货数据							
气管外径 D1	D5 ∅	D6 ∅	L1	每件重量 [g]	订货号	型号	PU*
4	10	7	16.5	2.5	153262	QSC-4	10
					130704	QSC-4-100	100
6	13	9	18.5	3.5	153263	QSC-6	10
					130705	QSC-6-100	100
8	15	11	20	5	153264	QSC-8	10
					130706	QSC-8-50	50
10	18	13	22.5	8	153265	QSC-10	10
					130707	QSC-10-50	50
12	21.5	16	23	11.5	153266	QSC-12	10
					130708	QSC-12-20	20

\* 包装单位数量

## 快插接头 QS...H

带插入式轴套

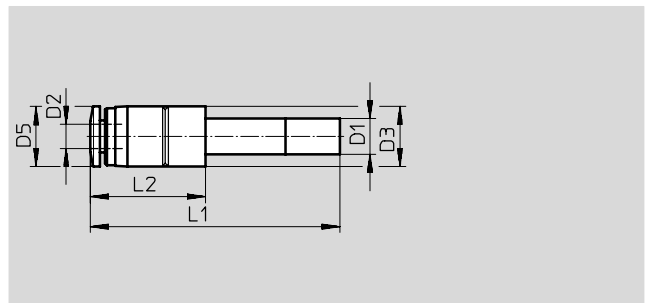

尺寸和订货数据										
插入式轴套 套∅ D1	公称通径 [mm]	气管外径 D2	D3 ∅	D5 ∅	L1	L2	每件重量 [g]	订货号	型号	PU*
6	2.5	4	10	9.9	37.7	15.2	2.9	153041	QS-6H-4	10
							130695	QS-6H-4-100	100	
8	2.4		12.5	9.9	40.2	16.7	3.8	130622	QS-8H-4	10
8	3.8	6	12.5	11.8	40.8	17.3	4	153042	QS-8H-6	10
								130696	QS-8H-6-50	50
10	3.8		12.5	11.8	43.8	18.8	4.5	130623	QS-10H-6	10
10	5.4	8	14.5	13.8	43.7	18.7	5.8	153043	QS-10H-8	10
								130697	QS-10H-8-50	50
12	5.4		14.5	13.8	49.7	20.7	6.7	130624	QS-12H-8	10
12	6.3	10	17.5	16.8	50	21	9.6	153044	QS-12H-10	10
								130698	QS-12H-10-20	20

\* 包装单位数量

# 快插/螺纹接头 QS

技术参数

FESTO

插入式轴套 QSH

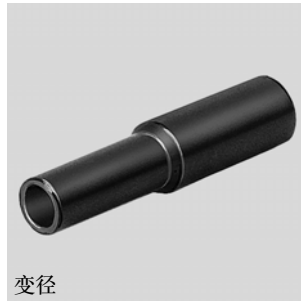
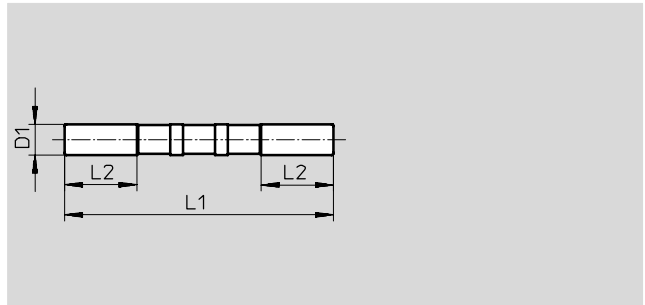

变径

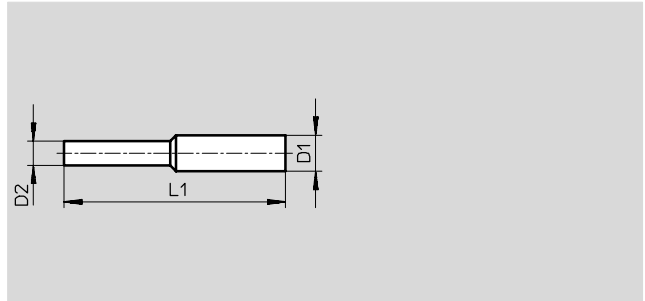

尺寸和订货数据								
插入式轴套 Ø	公称通径	插入式轴套 Ø	L1	L2	每件重量	订货号	型号	PU*
D1	[mm]	D2			[g]			
4	2.5	-	34.8	11.3	0.5	153251	QSH-4	10
						130723	QSH-4-100	100
6	4	-	38.2	11.3	0.5	153252	QSH-6	10
						130724	QSH-6-100	100
8	6	-	41.4	12.1	1	153253	QSH-8	10
						130725	QSH-8-50	50
10	7.5	-	46.2	13	1.5	153254	QSH-10	10
						130726	QSH-10-50	50
12	9	-	52.8	17.5	3	153255	QSH-12	10
						130727	QSH-12-20	20
16	11	-	55.6	18	4	153256	QSH-16	1
变径								
6	2.3	4	36.7	-	0.5	153257	QSH-6-4	10
						130718	QSH-6-4-100	100
8	2.3	4	41.1	-	0.9	130625	QSH-8-4	10
	3.8	6	40.5	-	0.9	153258	QSH-8-6	10
							130719	QSH-8-6-50
10	3.8	6	43.7	-	1.4	130626	QSH-10-6	10
	4.9	8	44	-	1.3	153259	QSH-10-8	10
							130720	QSH-10-8-50
12	3.6	8	47.5	-	2.1	130627	QSH-12-8	10
	7.1	10	49.6	-	2.2	153260	QSH-12-10	10
							130721	QSH-12-10-20
16	7.8	12	54.4	-	4.2	153261	QSH-16-12	1
						130722	QSH-16-12-20	20

\* 包装单位数量



# 快插/螺纹接头 QS

技术参数

FESTO

堵头 QSC...H

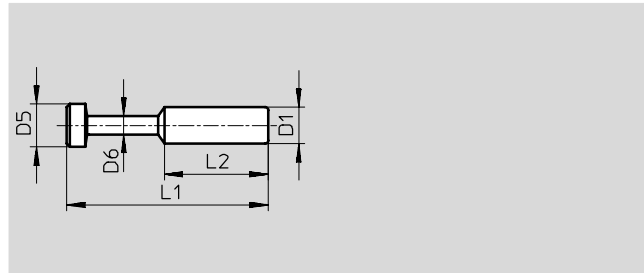

尺寸和订货数据								
插入式轴套 ∅ D1	D5 ∅	D6 ∅	L1	L2	每件重量 [g]	订货号	型号	PU*
4	5	3	28	15	0.5	153267	QSC-4H	10
						130699	QSC-4H-100	100
6	7	3	33	17	0.5	153268	QSC-6H	10
						130700	QSC-6H-100	100
8	9	4	37	18	1	153269	QSC-8H	10
						130701	QSC-8H-50	50
10	11	5	42	20.5	2	153270	QSC-10H	10
						130702	QSC-10H-50	50
12	13	6	44	23	2.5	153271	QSC-12H	10
						130703	QSC-12H-20	20
16	17	8	46	24	4	153272	QSC-16H	10

\* 包装单位数量

# 快插/螺纹接头 QS

技术参数

FESTO

## L形快插/螺纹接头QSL

360° 可旋转

外螺纹

带外六角



R 螺纹

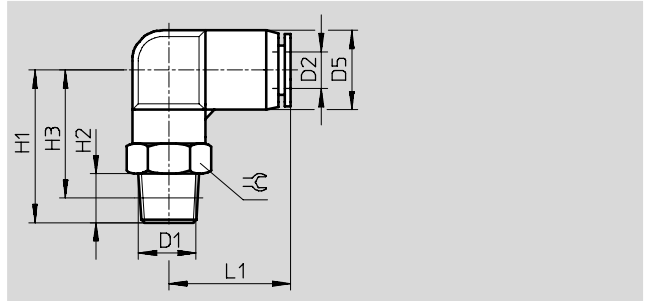

尺寸和订货数据												
接口	公称通径	气管外径	D5 ∅	H1	H2	H3	L1	≈C	每件重量 [g]	订货号	型号	PU*
D1	[mm]	D2										
<b>R 螺纹</b>												
R <sup>1</sup> / <sub>8</sub>	2.3	4	10	23.5	8	19.5	18.5	10	12	153045	QSL- <sup>1</sup> / <sub>8</sub> -4	10
										130728	QSL- <sup>1</sup> / <sub>8</sub> -4-100	100
	3.6	6	12.5	25	8	21	20	12	14	153046	QSL- <sup>1</sup> / <sub>8</sub> -6	10
										130729	QSL- <sup>1</sup> / <sub>8</sub> -6-100	100
	4.6	8	14.5	28	8	24	23	14	18	153048	QSL- <sup>1</sup> / <sub>8</sub> -8	10
130730										QSL- <sup>1</sup> / <sub>8</sub> -8-50	50	
5.3	10	17.5	33	8	29.1	26.2	17	31	190658	QSL- <sup>1</sup> / <sub>8</sub> -10	10	
R <sup>1</sup> / <sub>4</sub>	2.3	4	10	26.3	11	20.3	18	14	21	190659	QSL- <sup>1</sup> / <sub>4</sub> -4	10
										153047	QSL- <sup>1</sup> / <sub>4</sub> -6	10
	3.6	6	12.5	28	11	22	20	14	22	130731	QSL- <sup>1</sup> / <sub>4</sub> -6-100	100
										153049	QSL- <sup>1</sup> / <sub>4</sub> -8	10
	4.6	8	14.5	31	11	25	23	14	24	130732	QSL- <sup>1</sup> / <sub>4</sub> -8-50	50
										153051	QSL- <sup>1</sup> / <sub>4</sub> -10	10
6.2	10	17.5	37	11	30.5	26.5	17	34	130733	QSL- <sup>1</sup> / <sub>4</sub> -10-50	50	
7.7	12	21	38	11	32	29.5	21	50.5	164981	QSL- <sup>1</sup> / <sub>4</sub> -12	10	
									130734	QSL- <sup>1</sup> / <sub>4</sub> -12-20	20	
R <sup>3</sup> / <sub>8</sub>	3.6	6	12.5	29.8	12	23.7	19.7	17	35	190660	QSL- <sup>3</sup> / <sub>8</sub> -6	10
										153050	QSL- <sup>3</sup> / <sub>8</sub> -8	10
	4.6	8	14.5	33	12	26.5	23	17	37	130735	QSL- <sup>3</sup> / <sub>8</sub> -8-50	50
										153052	QSL- <sup>3</sup> / <sub>8</sub> -10	10
	6.2	10	17.5	40	12	32	26.5	17	42	130736	QSL- <sup>3</sup> / <sub>8</sub> -10-20	20
										153053	QSL- <sup>3</sup> / <sub>8</sub> -12	10
7.7	12	21	41.5	12	34	29.5	21	51.5	130737	QSL- <sup>3</sup> / <sub>8</sub> -12-20	20	
10.1	16	25	47	11	40.5	33.5	22	81.5	164958	QSL- <sup>3</sup> / <sub>8</sub> -16	1	
R <sup>1</sup> / <sub>2</sub>	6.2	10	17.5	40	15	31.9	26.2	21	64	190661	QSL- <sup>1</sup> / <sub>2</sub> -10	1
										153054	QSL- <sup>1</sup> / <sub>2</sub> -12	1
	7.7	12	21	41.5	15	33.5	29.5	21	66	130738	QSL- <sup>1</sup> / <sub>2</sub> -12-20	20
										153055	QSL- <sup>1</sup> / <sub>2</sub> -16	1
10.9	16	25	51	15	43	33.5	22	85.5	130739	QSL- <sup>1</sup> / <sub>2</sub> -16-20	20	

\* 包装单位数量

# 快插/螺纹接头 QS

技术参数

L形快插/螺纹接头QSL

360° 可旋转

外螺纹

带外六角

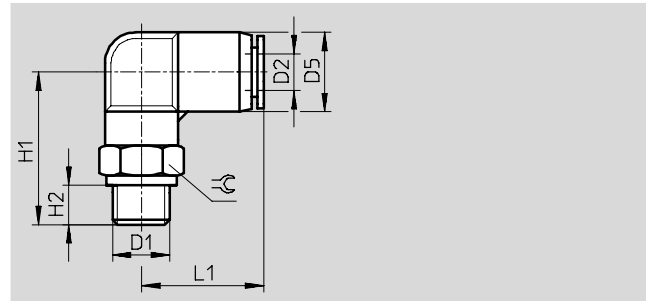

尺寸和订货数据												
接口	公称通径	气管外径	D5 ∅	H1	H2	H3	L1	≈G	每件重量 [g]	订货号	型号	PU*
D1	[mm]	D2										
<b>G 螺纹, 带密封圈</b>												
G <sup>1</sup> / <sub>8</sub>	2.3	4	10	23.3	5.1	-	18	13	14	<b>186116</b>	<b>QSL-G<sup>1</sup>/<sub>8</sub>-4</b>	<b>10</b>
										<b>132048</b>	<b>QSL-G<sup>1</sup>/<sub>8</sub>-4-100</b>	· 新产品 <b>100</b>
	3.6	6	12.5	24	5.1	-	19.8	13	15	<b>186117</b>	<b>QSL-G<sup>1</sup>/<sub>8</sub>-6</b>	<b>10</b>
										<b>132049</b>	<b>QSL-G<sup>1</sup>/<sub>8</sub>-6-100</b>	· 新产品 <b>100</b>
	4.6	8	14.5	27	5.1	-	22.7	14	18	<b>186119</b>	<b>QSL-G<sup>1</sup>/<sub>8</sub>-8</b>	<b>10</b>
										<b>132050</b>	<b>QSL-G<sup>1</sup>/<sub>8</sub>-8-50</b>	· 新产品 <b>50</b>
G <sup>1</sup> / <sub>4</sub>	3.6	6	12.5	25.5	5.6	-	19.8	17	24	<b>186118</b>	<b>QSL-G<sup>1</sup>/<sub>4</sub>-6</b>	<b>10</b>
										<b>132051</b>	<b>QSL-G<sup>1</sup>/<sub>4</sub>-6-100</b>	· 新产品 <b>100</b>
	4.6	8	14.5	28.5	5.6	-	22.7	17	26	<b>186120</b>	<b>QSL-G<sup>1</sup>/<sub>4</sub>-8</b>	<b>10</b>
										<b>132052</b>	<b>QSL-G<sup>1</sup>/<sub>4</sub>-8-50</b>	· 新产品 <b>50</b>
	6.2	10	17.5	32.5	5.6	-	26.2	17	32	<b>186122</b>	<b>QSL-G<sup>1</sup>/<sub>4</sub>-10</b>	<b>10</b>
										<b>132053</b>	<b>QSL-G<sup>1</sup>/<sub>4</sub>-10-50</b>	· 新产品 <b>50</b>
	6.2	12	21	34.5	5.6	-	29.4	21	51	<b>186351</b>	<b>QSL-G<sup>1</sup>/<sub>4</sub>-12</b>	<b>10</b>
										<b>132054</b>	<b>QSL-G<sup>1</sup>/<sub>4</sub>-12-20</b>	· 新产品 <b>20</b>
G <sup>3</sup> / <sub>8</sub>	4.6	8	14.5	30	6.6	-	22.7	19	39	<b>186121</b>	<b>QSL-G<sup>3</sup>/<sub>8</sub>-8</b>	<b>10</b>
										<b>132055</b>	<b>QSL-G<sup>3</sup>/<sub>8</sub>-8-50</b>	· 新产品 <b>50</b>
	6.2	10	17.5	34	6.6	-	26.2	19	42	<b>186123</b>	<b>QSL-G<sup>3</sup>/<sub>8</sub>-10</b>	<b>10</b>
										<b>132056</b>	<b>QSL-G<sup>3</sup>/<sub>8</sub>-10-20</b>	· 新产品 <b>20</b>
	7.7	12	21	36	6.6	-	29.4	21	45	<b>186124</b>	<b>QSL-G<sup>3</sup>/<sub>8</sub>-12</b>	<b>10</b>
									<b>132057</b>	<b>QSL-G<sup>3</sup>/<sub>8</sub>-12-20</b>	· 新产品 <b>20</b>	
	10.1	16	25	45	6.6	-	33.1	24	83	<b>186348</b>	<b>QSL-G<sup>3</sup>/<sub>8</sub>-16</b>	<b>1</b>
G <sup>1</sup> / <sub>2</sub>	7.7	12	21	39	7.6	-	29.4	24	70	<b>186125</b>	<b>QSL-G<sup>1</sup>/<sub>2</sub>-12</b>	<b>1</b>
										<b>132058</b>	<b>QSL-G<sup>1</sup>/<sub>2</sub>-12-20</b>	· 新产品 <b>20</b>
	10.9	16	25	46	7.6	-	33.1	24	82	<b>186126</b>	<b>QSL-G<sup>1</sup>/<sub>2</sub>-16</b>	<b>1</b>
									<b>132059</b>	<b>QSL-G<sup>1</sup>/<sub>2</sub>-16-20</b>	· 新产品 <b>20</b>	

\* 包装单位数量

# 快插/螺纹接头 QS

技术参数

加长 L形快插/螺纹接头 QSLL

360° 可旋转

外螺纹

带外六角

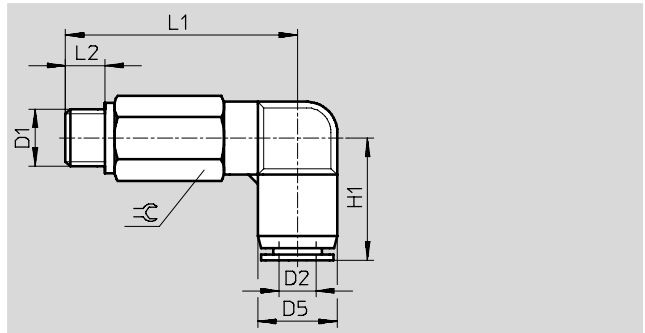
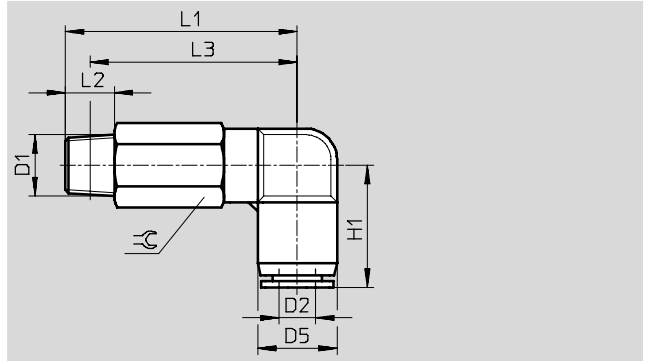

尺寸和订货数据												
接口	公称通径	气管外径	D5	H1	L1	L2	L3	☉	每件重量	订货号	型号	PU*
D1	[mm]	D2	∅						[g]			
<b>R 螺纹</b>												
R <sup>1</sup> / <sub>8</sub>	2.3	4	10	17	37	8	32.5	10	18	153076	QSLL-R <sup>1</sup> / <sub>8</sub> -4	10
	3.6	6	12.5	20	38	8	34	12	26	153077	QSLL-R <sup>1</sup> / <sub>8</sub> -6	10
	4.6	8	14.5	22.5	43.5	8	39.5	14	36.5	153079	QSLL-R <sup>1</sup> / <sub>8</sub> -8	10
R <sup>1</sup> / <sub>4</sub>	2.9	4	10	18	38.3	11	32.3	14	34	190662	QSLL-R <sup>1</sup> / <sub>4</sub> -4	10
	3.6	6	12.5	20	41	11	35	14	39	153078	QSLL-R <sup>1</sup> / <sub>4</sub> -6	10
	4.6	8	14.5	22.5	46.5	11	40.5	14	42.5	153080	QSLL-R <sup>1</sup> / <sub>4</sub> -8	10
	6.2	10	17.5	26	54.5	11	48.5	17	65	153082	QSLL-R <sup>1</sup> / <sub>4</sub> -10	10
R <sup>3</sup> / <sub>8</sub>	3.5	6	12.5	19.7	43.3	12	37.2	17	61	190663	QSLL-R <sup>3</sup> / <sub>8</sub> -6	10
	4.8	8	14.5	22.5	48.5	12	42	17	65.5	153081	QSLL-R <sup>3</sup> / <sub>8</sub> -8	10
	6.2	10	17.5	26	55.5	12	49	17	73	153083	QSLL-R <sup>3</sup> / <sub>8</sub> -10	10
	7.5	12	21	29.5	61	12	54.5	21	107	153084	QSLL-R <sup>3</sup> / <sub>8</sub> -12	10
R <sup>1</sup> / <sub>2</sub>	6.4	10	17.5	26.2	60	15	51.9	21	120	190664	QSLL-R <sup>1</sup> / <sub>2</sub> -10	1
	8.3	12	21	29.5	64	15	56	21	122	153085	QSLL-R <sup>1</sup> / <sub>2</sub> -12	1
<b>G 螺纹</b>												
G <sup>1</sup> / <sub>8</sub>	2.3	4	10	18	34.3	5.1	-	13	24	186127	QSLL-G <sup>1</sup> / <sub>8</sub> -4	10
	3.6	6	12.5	19.8	37	5.1	-	13	29	186128	QSLL-G <sup>1</sup> / <sub>8</sub> -6	10
	4.6	8	14.5	22.7	42.5	5.1	-	14	36	186130	QSLL-G <sup>1</sup> / <sub>8</sub> -8	10
G <sup>1</sup> / <sub>4</sub>	3.6	6	12.5	19.8	37.5	5.6	-	17	48	186129	QSLL-G <sup>1</sup> / <sub>4</sub> -6	10
	4.6	8	14.5	22.7	43	5.6	-	17	53	186131	QSLL-G <sup>1</sup> / <sub>4</sub> -8	10
	6.2	10	17.5	26.2	51	5.6	-	17	63	186133	QSLL-G <sup>1</sup> / <sub>4</sub> -10	10
	8.0	12	21	29.4	56.5	5.6	-	21	109	132596	QSLL-G <sup>1</sup> / <sub>4</sub> -12	☉ 新产品 10
G <sup>3</sup> / <sub>8</sub>	4.8	8	14.5	22.7	45.3	6.6	-	19	73	186132	QSLL-G <sup>3</sup> / <sub>8</sub> -8	10
	6.2	10	17.5	26.2	52.5	6.6	-	19	82	186134	QSLL-G <sup>3</sup> / <sub>8</sub> -10	10
	7.5	12	21	29.4	58	6.6	-	21	104	186135	QSLL-G <sup>3</sup> / <sub>8</sub> -12	10
G <sup>1</sup> / <sub>2</sub>	8.3	12	21	29.4	59	7.6	-	24	140	186136	QSLL-G <sup>1</sup> / <sub>2</sub> -12	1
	10	16	25	33.1	73	7.6	-	24	164	190665	QSLL-G <sup>1</sup> / <sub>2</sub> -16	1

\* 包装单位数量

# 快插/螺纹接头 QS

技术参数

L形快插/螺纹接头 QSLF  
内螺纹  
带外六角

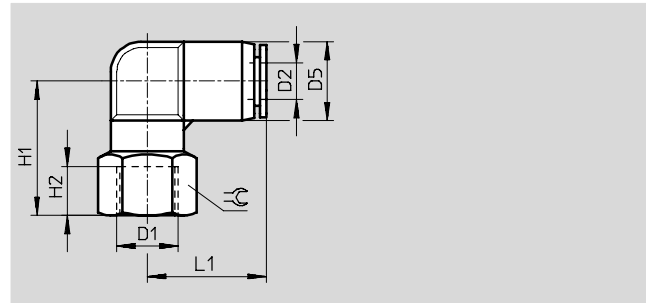

尺寸和订货数据											
接口	公称通径	气管外径	D5 ∅	H1	H2	L1	≈	每件重量 [g]	订货号	型号	PU*
D1	[mm]	D2									
<b>G 螺纹</b>											
G <sup>1</sup> / <sub>8</sub>	2.1	4	10	21.3	7	18	14	13	153273	QSLF- <sup>1</sup> / <sub>8</sub> -4-B	10
	3.6	6	12.5	22	7	19.8	14	16	153274	QSLF- <sup>1</sup> / <sub>8</sub> -6-B	10
	4.7	8	14.5	25	7	22.7	14	19	153276	QSLF- <sup>1</sup> / <sub>8</sub> -8-B	10
G <sup>1</sup> / <sub>4</sub>	3.6	6	12.5	25	9	19.8	17	22	153275	QSLF- <sup>1</sup> / <sub>4</sub> -6-B	10
	4.7	8	14.5	28	9	22.7	17	25	153277	QSLF- <sup>1</sup> / <sub>4</sub> -8-B	10
	5.4	10	17.5	32	9	26.2	19	39	153279	QSLF- <sup>1</sup> / <sub>4</sub> -10-B	10
G <sup>3</sup> / <sub>8</sub>	4.8	8	14.5	29	11	22.7	21	31	153278	QSLF- <sup>3</sup> / <sub>8</sub> -8-B	10
	6.2	10	17.5	33	11	26.2	21	40	153280	QSLF- <sup>3</sup> / <sub>8</sub> -10-B	10

\* 包装单位数量

# 快插/螺纹接头 QS

技术参数

FESTO

## L形快插/螺纹接头 QSLV...-I

360° 可旋转

外螺纹

带内六角



R 螺纹

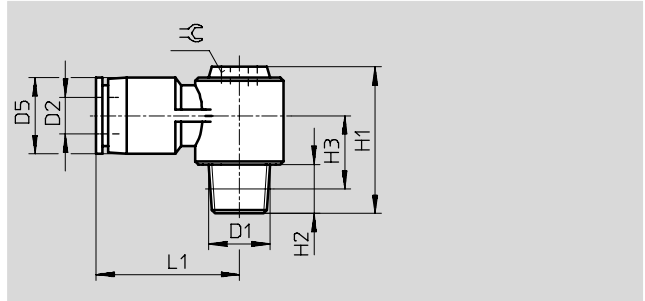

G 螺纹

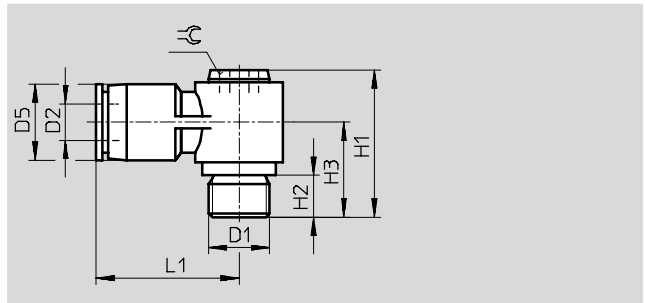

尺寸和订货数据												
接口	公称通径	气管外径	D5 Ø	H1	H2	H3	L1	≈	每件重量	订货号	型号	PU*
D1	[mm]	D2							[g]			
<b>R 螺纹</b>												
R1/8	3	6	13	24	8	11.5	23.5	5	15	153097	QSLV-1/8-6-I	10
	4.2	8	14	27	8	12	26.5	8	22	153099	QSLV-1/8-8-I	10
R1/4	3.1	6	13	27	11	12.5	23.5	5	21.5	153098	QSLV-1/4-6-I	10
	4	8	14	30	11	13	26.5	8	28	153100	QSLV-1/4-8-I	10
	5.4	10	18	34	11	14.5	30.5	10	41	153102	QSLV-1/4-10-I	10
R3/8	4.2	8	14	31	12	13.5	26.5	8	36.5	153101	QSLV-3/8-8-I	10
	5.4	10	18	35	12	15.5	30.5	10	49.5	153103	QSLV-3/8-10-I	10
	6.9	12	21	39	12	17	36.5	12	68	153104	QSLV-3/8-12-I	10
R1/2	6.4	12	21	42	15	16.5	36.5	12	83	153105	QSLV-1/2-12-I	1
<b>G 螺纹</b>												
G1/8	3	6	13	23	5.1	14.5	23.7	5	15	186148	QSLV-G1/8-6-I	10
	4.2	8	14	26	5.1	15	26.7	8	22	186150	QSLV-G1/8-8-I	10
G1/4	3.1	6	13	23.5	5.6	15	23.7	5	19	186149	QSLV-G1/4-6-I	10
	4	8	14	26.5	5.6	15.5	26.7	8	25	186151	QSLV-G1/4-8-I	10
	5.4	10	18	30.5	5.6	17.5	30.7	10	38	186153	QSLV-G1/4-10-I	10
G3/8	4.2	8	14	28	6.6	17	26.7	8	33	186152	QSLV-G3/8-8-I	10
	5.4	10	18	32	6.6	19	30.7	10	45	186154	QSLV-G3/8-10-I	10
	6.9	12	21	36	6.6	21	36.4	12	65	186155	QSLV-G3/8-12-I	10
G1/2	6.4	12	21	37	7.6	22	36.4	12	75	186156	QSLV-G1/2-12-I	1

\* 包装单位数量

# 快插/螺纹接头 QS

技术参数

FESTO

## L形快插/螺纹接头 QSLV

360° 可旋转

外螺纹

带外六角

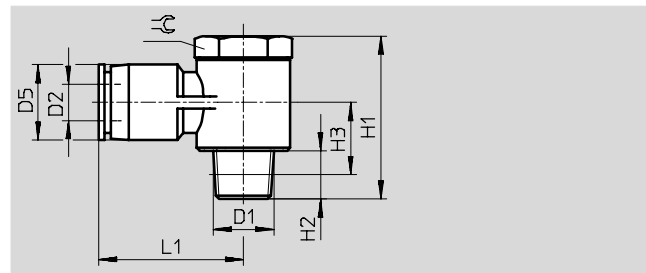
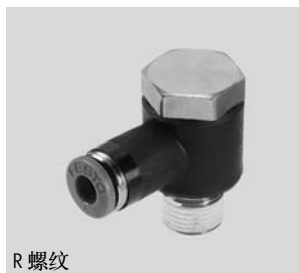
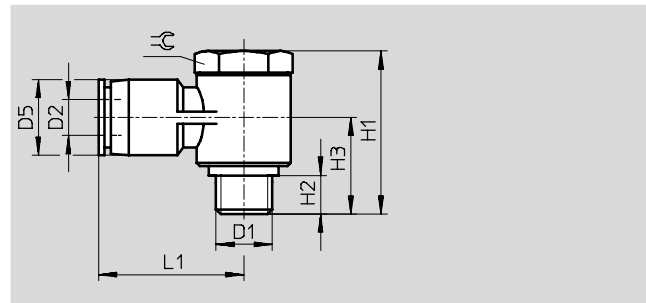

尺寸和订货数据												
接口	公称通径	气管外径	D5	H1	H2	H3	L1	≈C	每件重量	订货号	型号	PU*
D1	[mm]	D2	∅						[g]			
<b>公制螺纹</b>												
M5	1.6	6	12.5	17.7	3.5	10.9	23.1	8	8.2	190666	QSLV-M-5-6	10
<b>R 螺纹</b>												
R1/8	2.4	4	10	27	8	12	22.5	14	20	153086	QSLV-1/8-4	10
										130749	QSLV-1/8-4-100	100
	3.7	6	12.5	27	8	12	24	14	35.5	153087	QSLV-1/8-6	10
										130750	QSLV-1/8-6-100	100
R1/4	4.4	8	14.5	27	8	12	26	14	37	153089	QSLV-1/8-8	10
										130751	QSLV-1/8-8-50	50
	3.8	6	12.5	31.5	11	13.5	27	17	32.5	153088	QSLV-1/4-6	10
										130752	QSLV-1/4-6-100	100
R1/4	5	8	14.5	31.5	11	13.5	28.5	17	59.5	153090	QSLV-1/4-8	10
										130753	QSLV-1/4-8-50	50
	5.4	10	17.5	31.5	11	14.5	30.5	17	62.5	153092	QSLV-1/4-10	10
										130754	QSLV-1/4-10-50	50
R3/8	5.2	8	14.5	36	12	15.5	30.5	21	54.5	153091	QSLV-3/8-8	10
	6.3	10	17.5	36	12	15.5	33	21	66	153093	QSLV-3/8-10	10
	7.1	12	21	36	12	17	35	21	97.5	153094	QSLV-3/8-12	10
R1/2	8	12	21	40.5	15	16.5	38	24	100	153095	QSLV-1/2-12	1
	8.9	16	25	48.5	15	22	36.5	24	115	153096	QSLV-1/2-16	1

\* 包装单位数量

# 快插/螺纹接头 QS

技术参数

L形快插/螺纹接头QSLV

360° 可旋转

外螺纹

带外六角

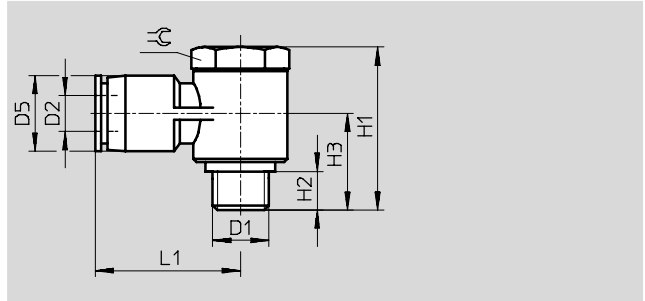

尺寸和订货数据												
接口	公称通径	气管外径	D5 ∅	H1	H2	H3	L1	≈	每件重量	订货号	型号	PU*
D1	[mm]	D2							[g]			
<b>G 螺纹</b>												
G <sup>1</sup> / <sub>8</sub>	2.3	4	10	23.7	5.1	13.8	23.4	14	22	186137	QSLV-G <sup>1</sup> / <sub>8</sub> -4	10
										132060	QSLV-G <sup>1</sup> / <sub>8</sub> -4-100	· 新产品
	3.5	6	12.4	23.7	5.1	14.1	25.5	14	23	186138	QSLV-G <sup>1</sup> / <sub>8</sub> -6	10
										132061	QSLV-G <sup>1</sup> / <sub>8</sub> -6-100	· 新产品
	4	8	14.4	23.7	5.1	15.1	28.4	14	25	186140	QSLV-G <sup>1</sup> / <sub>8</sub> -8	10
										132062	QSLV-G <sup>1</sup> / <sub>8</sub> -8-50	· 新产品
G <sup>1</sup> / <sub>4</sub>	3.7	6	12.4	28.6	5.6	16	29	19	44	186139	QSLV-G <sup>1</sup> / <sub>4</sub> -6	10
										132063	QSLV-G <sup>1</sup> / <sub>4</sub> -6-100	· 新产品
	4.9	8	14.4	28.6	5.6	16	28.9	19	45	186141	QSLV-G <sup>1</sup> / <sub>4</sub> -8	10
										132064	QSLV-G <sup>1</sup> / <sub>4</sub> -8-50	· 新产品
	5.3	10	17.6	28.6	5.6	17.3	31.2	19	48	186143	QSLV-G <sup>1</sup> / <sub>4</sub> -10	10
										132065	QSLV-G <sup>1</sup> / <sub>4</sub> -10-50	· 新产品
G <sup>3</sup> / <sub>8</sub>	5.4	8	14.4	33.1	6.6	19.2	31	24	71	186142	QSLV-G <sup>3</sup> / <sub>8</sub> -8	10
	6.4	10	17.6	33.1	6.6	19.2	33.6	24	74	186144	QSLV-G <sup>3</sup> / <sub>8</sub> -10	10
	6.4	12	21	33.1	6.6	20.9	36.4	24	77	186145	QSLV-G <sup>3</sup> / <sub>8</sub> -12	10
G <sup>1</sup> / <sub>2</sub>	7	12	21	34	7.6	21.9	37.9	27	99	186146	QSLV-G <sup>1</sup> / <sub>2</sub> -12	1
	8.1	16	25	43.1	7.6	24.8	38.1	27	115	186147	QSLV-G <sup>1</sup> / <sub>2</sub> -16	1

\* 包装单位数量



# 快插/螺纹接头 QS

技术参数

FESTO

## L形快插接头 QSL

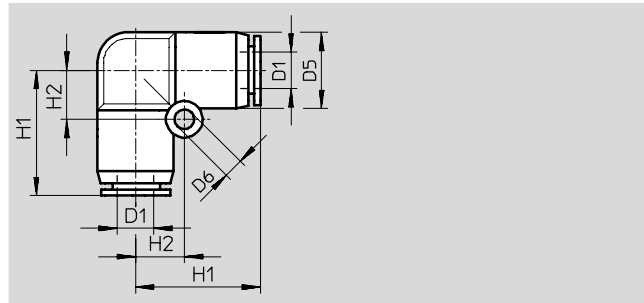

尺寸和订货数据									
气管外径	公称通径	D5	D6	H1	H2	每件重量	订货号	型号	PU*
D1	[mm]	∅	∅			[g]			
4	2.3	10	-	17	-	5	153070	QSL-4	10
							130740	QSL-4-100	100
6	3.6	12.5	3.2	20.5	8	7.5	153071	QSL-6	10
							130741	QSL-6-100	100
8	4.6	15	4.2	22	10	10	153072	QSL-8	10
							130742	QSL-8-50	50
10	6.2	17.5	4.2	26	12	17	153073	QSL-10	10
							130743	QSL-10-50	50
12	7.7	21	4.2	29	14	24.5	153074	QSL-12	10
							130744	QSL-12-20	20
16	10.8	25	4.2	33	12	30	153075	QSL-16	1

\* 包装单位数量

# 快插/螺纹接头 QS

技术参数

FESTO

L形快插接头 QSL-...H  
带轴套

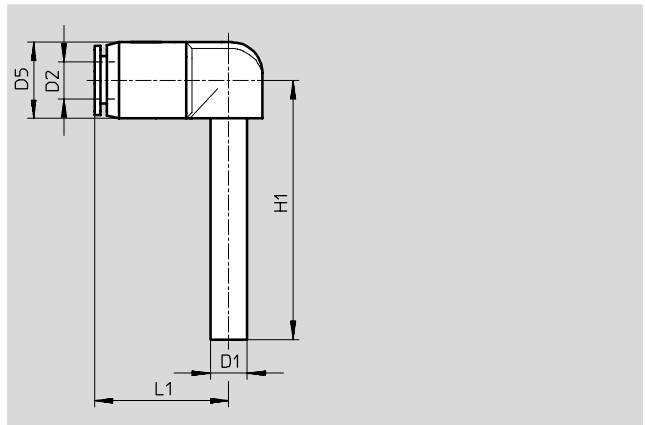
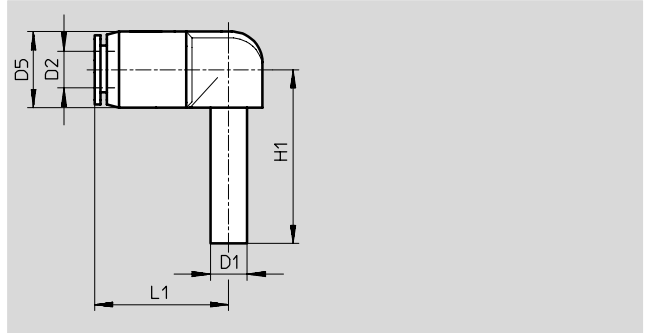

加长轴套

尺寸和订货数据									
轴套 Ø D1	公称通径 [mm]	气管外径 D2	D5 Ø	H1	L1	每件重量 [g]	订货号	型号	PU*
4	2	4	10	25	16.8	2.7	153056	QSL-4H	10
							130745	QSL-4H-100	100
6	3.2	6	12.5	28.5	19.8	3.9	153057	QSL-6H	10
							130746	QSL-6H-100	100
8	4.7	8	14.5	30.7	21.8	5.7	153058	QSL-8H	10
							130747	QSL-8H-50	50
10	6.2	10	17.5	33.7	24.9	9.6	153059	QSL-10H	10
							130748	QSL-10H-50	50
12	7.4	12	21	39	28.9	15	153060	QSL-12H	10
变径									
6	2.4	4	12.5	28.5	17.7	3.6	153061	QSL-6H-4	10
8	3.5	6	14.5	30.7	21.9	5.2	153062	QSL-8H-6	10
10	4.7	8	17.5	33.7	24.6	8	153063	QSL-10H-8	10
12	6	10	21	39	28.7	14	153064	QSL-12H-10	10
加长轴套									
4	2	4	10	36	16.8	2.8	153065	QSL-4HL	10
6	3.1	6	12.5	42	19.8	4.2	153066	QSL-6HL	10
8	4.5	8	14.5	46.7	21.8	6.2	153067	QSL-8HL	10
10	5.8	10	17.5	51.7	24.9	11	153068	QSL-10HL	10
12	7.4	12	21	59.5	28.95	16	153069	QSL-12HL	10

\* 包装单位数量

# 快插/螺纹接头 QS

技术参数

FESTO

## T形快插/螺纹接头QST

360° 可旋转

外螺纹

带外六角

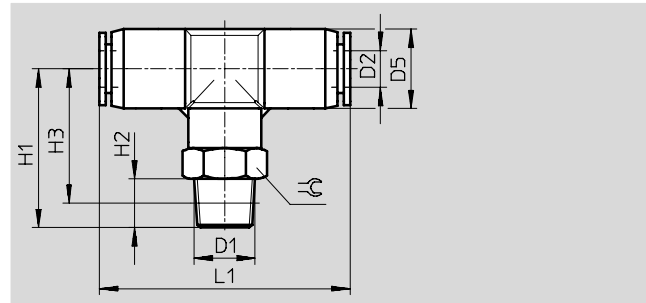

尺寸和订货数据												
接口	公称通径	气管外径	D5 ∅	H1	H2	H3	L1	≈	每件重量	订货号	型号	PU*
D1	[mm]	D2							[g]			
<b>R 螺纹</b>												
R <sup>1</sup> / <sub>8</sub>	4.1	4	10	23.5	8	19.5	34	10	14	<b>153106</b>	<b>QST-<sup>1</sup>/<sub>8</sub>-4</b>	<b>10</b>
										<b>130793</b>	<b>QST-<sup>1</sup>/<sub>8</sub>-4-100</b>	<b>100</b>
	4.7	6	13	26	8	22	41	12	17.5	<b>153107</b>	<b>QST-<sup>1</sup>/<sub>8</sub>-6</b>	<b>10</b>
										<b>130794</b>	<b>QST-<sup>1</sup>/<sub>8</sub>-6-100</b>	<b>100</b>
	5.4	8	15	26.5	8	22.5	45	14	22.5	<b>153109</b>	<b>QST-<sup>1</sup>/<sub>8</sub>-8</b>	<b>10</b>
										<b>130795</b>	<b>QST-<sup>1</sup>/<sub>8</sub>-8-50</b>	<b>50</b>
R <sup>1</sup> / <sub>4</sub>	5.6	10	17.5	33	8	29.1	50.4	17	38.5	<b>190667</b>	<b>QST-<sup>1</sup>/<sub>8</sub>-10</b>	<b>10</b>
	2.3	4	10	26.3	11	20.3	33.8	14	24	<b>190668</b>	<b>QST-<sup>1</sup>/<sub>4</sub>-4</b>	<b>10</b>
	5.7	6	13	29	11	23	41	14	25.5	<b>153108</b>	<b>QST-<sup>1</sup>/<sub>4</sub>-6</b>	<b>10</b>
										<b>130796</b>	<b>QST-<sup>1</sup>/<sub>4</sub>-6-100</b>	<b>100</b>
	6	8	15	29.5	11	23.5	45	14	28	<b>153110</b>	<b>QST-<sup>1</sup>/<sub>4</sub>-8</b>	<b>10</b>
											<b>130797</b>	<b>QST-<sup>1</sup>/<sub>4</sub>-8-50</b>
R <sup>3</sup> / <sub>8</sub>	7.3	10	17.5	36	11	30	51	17	41.5	<b>153112</b>	<b>QST-<sup>1</sup>/<sub>4</sub>-10</b>	<b>10</b>
										<b>130798</b>	<b>QST-<sup>1</sup>/<sub>4</sub>-10-50</b>	<b>50</b>
	6.2	12	21	38	11	32	56.8	21	61.5	<b>190669</b>	<b>QST-<sup>1</sup>/<sub>4</sub>-12</b>	<b>10</b>
	3.6	6	13	30.8	12	24.4	40.2	17	38.5	<b>190670</b>	<b>QST-<sup>3</sup>/<sub>8</sub>-6</b>	<b>10</b>
	7.2	8	15	31.5	12	25	45	17	41	<b>153111</b>	<b>QST-<sup>3</sup>/<sub>8</sub>-8</b>	<b>10</b>
										<b>130799</b>	<b>QST-<sup>3</sup>/<sub>8</sub>-8-50</b>	<b>50</b>
R <sup>3</sup> / <sub>8</sub>	8	10	17.5	37	12	30.5	51	17	50.5	<b>153113</b>	<b>QST-<sup>3</sup>/<sub>8</sub>-10</b>	<b>10</b>
										<b>130800</b>	<b>QST-<sup>3</sup>/<sub>8</sub>-10-20</b>	<b>20</b>
	8.8	12	21	39	12	32.5	56	21	61.5	<b>153114</b>	<b>QST-<sup>3</sup>/<sub>8</sub>-12</b>	<b>10</b>
										<b>130801</b>	<b>QST-<sup>3</sup>/<sub>8</sub>-12-20</b>	<b>20</b>
	10.1	16	25	47	11	40.5	67	22	95	<b>164959</b>	<b>QST-<sup>3</sup>/<sub>8</sub>-16</b>	<b>1</b>
R <sup>1</sup> / <sub>2</sub>	6.2	10	17.5	40	15	31.9	50.4	21	72.5	<b>190672</b>	<b>QST-<sup>1</sup>/<sub>2</sub>-10</b>	<b>1</b>
	9.9	12	21	42	15	34	56	21	77	<b>153115</b>	<b>QST-<sup>1</sup>/<sub>2</sub>-12</b>	<b>1</b>
	11.2	16	25	51	15	43	67	22	99	<b>153116</b>	<b>QST-<sup>1</sup>/<sub>2</sub>-16</b>	<b>1</b>

\* 包装单位数量

# 快插/螺纹接头 QS

技术参数

## T形快插/螺纹接头QST

360° 可旋转

外螺纹

带外六角

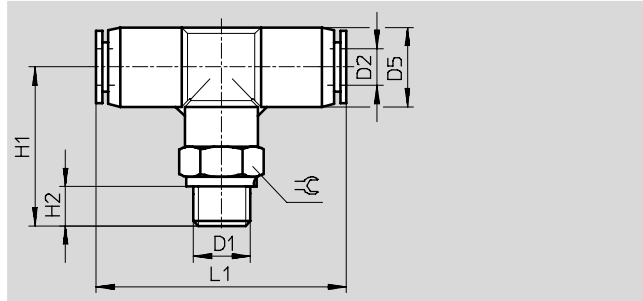

尺寸和订货数据												
接口	公称通径	气管外径	D5 ∅	H1	H2	L1	⊕	每件重量	订货号	型号		PU*
D1	[mm]	D2						[g]				
<b>G 螺纹</b>												
G <sup>1</sup> / <sub>8</sub>	2.3	4	10	23.3	5.1	33.8	13	16	186157	QST-G <sup>1</sup> / <sub>8</sub> -4		10
									132066	QST-G <sup>1</sup> / <sub>8</sub> -4-100		100
	3.6	6	13	25	5.1	40.3	13	18	186158	QST-G <sup>1</sup> / <sub>8</sub> -6		10
									132067	QST-G <sup>1</sup> / <sub>8</sub> -6-100		100
	4.6	8	15	25.3	5.1	44.8	14	22	186160	QST-G <sup>1</sup> / <sub>8</sub> -8		10
									132068	QST-G <sup>1</sup> / <sub>8</sub> -8-50		50
G <sup>1</sup> / <sub>4</sub>	3.6	6	13	26.5	5.6	40.3	17	27	186159	QST-G <sup>1</sup> / <sub>4</sub> -6		10
									132069	QST-G <sup>1</sup> / <sub>4</sub> -6-100		100
	4.6	8	15	26.8	5.6	44.8	17	31	186161	QST-G <sup>1</sup> / <sub>4</sub> -8		10
									132070	QST-G <sup>1</sup> / <sub>4</sub> -8-50		50
	6.2	10	17.5	32.5	5.6	50.4	17	39	186163	QST-G <sup>1</sup> / <sub>4</sub> -10		10
									132071	QST-G <sup>1</sup> / <sub>4</sub> -10-50		50
8.0	12	21	34.5	5.6	56.8	21	58	132597	QST-G <sup>1</sup> / <sub>4</sub> -12	· 新产品	10	
G <sup>3</sup> / <sub>8</sub>	4.6	8	15	28.3	6.6	44.8	19	44	186162	QST-G <sup>3</sup> / <sub>8</sub> -8		10
									132072	QST-G <sup>3</sup> / <sub>8</sub> -8-50		50
	6.2	10	17.5	34	6.6	50.4	19	49	186164	QST-G <sup>3</sup> / <sub>8</sub> -10		10
									132073	QST-G <sup>3</sup> / <sub>8</sub> -10-20		20
	7.7	12	21	36	6.6	56.8	21	56	186165	QST-G <sup>3</sup> / <sub>8</sub> -12		10
									132074	QST-G <sup>3</sup> / <sub>8</sub> -12-20		20
10.2	16	25	45	6.6	66.2	24	97	186349	QST-G <sup>3</sup> / <sub>8</sub> -16		1	
G <sup>1</sup> / <sub>2</sub>	7.7	12	21	39	7.6	56.8	24	81	186166	QST-G <sup>1</sup> / <sub>2</sub> -12		1
									186167	QST-G <sup>1</sup> / <sub>2</sub> -16		1

\* 包装单位数量

# 快插/螺纹接头 QS

技术参数



## T形快插接头 QST

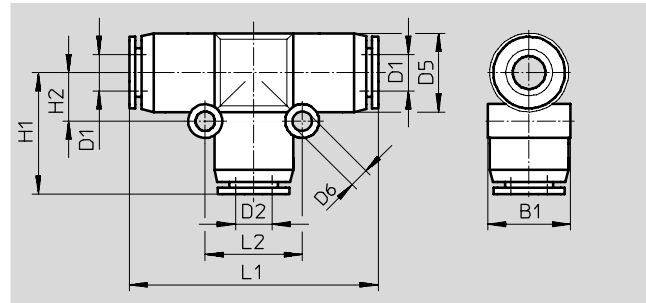

尺寸和订货数据													
气管外径	公称通径	气管外径	D5 ∅	D6 ∅	B1	H1	H2	L1	L2	每件重量	订货号	型号	PU*
D1	[mm]	D2								[g]			
4	2.6	4	10	-	-	17	-	34	-	7	153128	QST-4	10
											130802	QST-4-100	100
6	4	6	13	3.2	-	20	8	40	16	10.5	153129	QST-6	10
											130803	QST-6-100	100
8	5	8	15	3.2	-	22	9	44	18	15.5	153130	QST-8	10
											130804	QST-8-50	50
10	6.7	10	18	4.2	-	25.5	12	51	24	25.5	153131	QST-10	10
											130805	QST-10-50	50
12	8.7	12	21.5	4.2	-	28	14	56	28	36	153132	QST-12	10
											130806	QST-12-20	20
16	10.7	16	25.5	4.2	-	33	12	66	24	43.5	153133	QST-16	1
变径													
6	2.3	4	13	3.2	13	19.5	8	40.1	16	11	153134	QST-6-4	10
											130820	QST-6-4-100	100
8	2.3	4	14.5	3.2	15,1	21.7	9	44.4	18	14	130613	QST-8-4	10
	3.5	6	14.5	3.2	15,1	22.3	9	44.4	18	14	153135	QST-8-6	10
											130821	QST-8-6-50	50
10	3.7	6	17.5	4.2	18,2	25	12	50.4	24	22	130614	QST-10-6	10
	4.9	8	17.5	4.2	18,2	24.9	12	50.4	24	23	153136	QST-10-8	10
											130822	QST-10-8-50	50
12	5.1	8	21	4.2	21,7	27.7	14	56.8	28	32	130615	QST-12-8	10
	6.1	10	21	4.2	21,7	28	14	56.8	28	34	153137	QST-12-10	10
											130823	QST-12-10-20	20
16	7.6	12	25	4.2	25,7	33.2	12	66.2	24	45	130616	QST-16-12	1

\* 包装单位数量

# 快插/螺纹接头 QS

技术参数

FESTO

## T形快插/螺纹接头QSTF

360° 可旋转

带外螺纹和内螺纹



R 螺纹

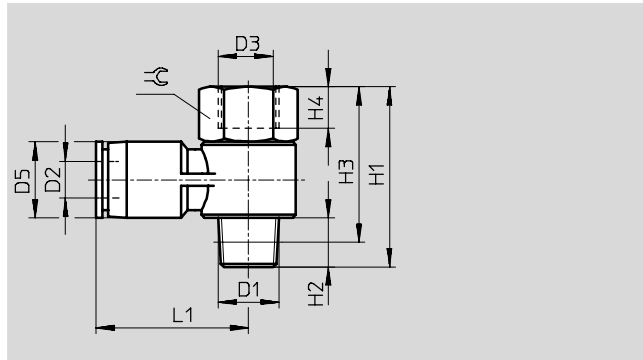

G 螺纹

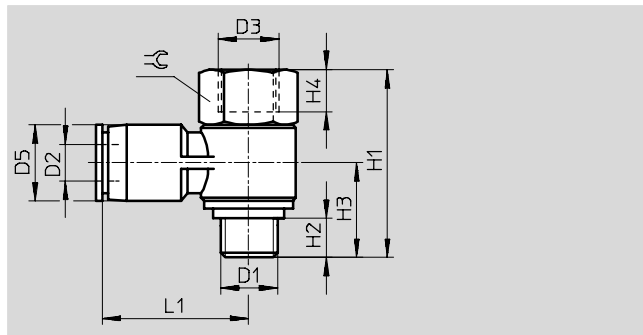

尺寸和订货数据														
接口	公称通径	气管外径	D3	D5	H1	H2	H3	H4	L1	☩	每件重量	订货号	型号	PU*
D1	[mm]	D2	∅	∅							[g]			
<b>R 螺纹</b>														
R <sup>1</sup> / <sub>8</sub>	2.5	4	G <sup>1</sup> / <sub>8</sub>	10	32.5	8	28.5	7	22.2	14	22	153182	QSTF- <sup>1</sup> / <sub>8</sub> -4-B	1
	3.3	6	G <sup>1</sup> / <sub>8</sub>	12.5	32.5	8	28.5	7	24.2	14	23	153183	QSTF- <sup>1</sup> / <sub>8</sub> -6-B	1
	3.6	8	G <sup>1</sup> / <sub>8</sub>	14.5	32.5	8	28.5	7	26.2	14	25	153185	QSTF- <sup>1</sup> / <sub>8</sub> -8-B	1
R <sup>1</sup> / <sub>4</sub>	3.6	6	G <sup>1</sup> / <sub>4</sub>	12.5	38.5	11	32.5	9	26.8	17	37	153184	QSTF- <sup>1</sup> / <sub>4</sub> -6-B	1
	4.4	8	G <sup>1</sup> / <sub>4</sub>	14.5	38.5	11	32.5	9	28.2	17	39	153186	QSTF- <sup>1</sup> / <sub>4</sub> -8-B	1
	4.4	10	G <sup>1</sup> / <sub>4</sub>	18	38.5	11	32.5	9	30.5	17	42	153188	QSTF- <sup>1</sup> / <sub>4</sub> -10-B	1
R <sup>3</sup> / <sub>8</sub>	4.9	8	G <sup>3</sup> / <sub>8</sub>	14.5	44.5	12	38.2	11	30.2	21	61	153187	QSTF- <sup>3</sup> / <sub>8</sub> -8-B	1
	5.6	10	G <sup>3</sup> / <sub>8</sub>	18	44.5	12	38.2	11	32.5	21	64	153189	QSTF- <sup>3</sup> / <sub>8</sub> -10-B	1
	6	12	G <sup>3</sup> / <sub>8</sub>	21	44.5	12	38.2	11	35.2	21	67	153190	QSTF- <sup>3</sup> / <sub>8</sub> -12-B	1
R <sup>1</sup> / <sub>2</sub>	7.4	12	G <sup>1</sup> / <sub>2</sub>	21	52.2	13	44	14	38.2	24	101	153191	QSTF- <sup>1</sup> / <sub>2</sub> -12-B	1
<b>G 螺纹, 带密封圈</b>														
G <sup>1</sup> / <sub>8</sub>	2.4	4	G <sup>1</sup> / <sub>8</sub>	10	26	5.1	13.8	7	23.4	14	20	186199	QSTF-G <sup>1</sup> / <sub>8</sub> -4	1
	3.2	6	G <sup>1</sup> / <sub>8</sub>	12.4	26	5.1	14.1	7	25.5	14	21	186200	QSTF-G <sup>1</sup> / <sub>8</sub> -6	1
	3.7	8	G <sup>1</sup> / <sub>8</sub>	14.4	26	5.1	15.1	7	28.4	14	23	186202	QSTF-G <sup>1</sup> / <sub>8</sub> -8	1
G <sup>1</sup> / <sub>4</sub>	3.7	6	G <sup>1</sup> / <sub>4</sub>	12.4	33.2	5.6	16	9	29	19	43	186201	QSTF-G <sup>1</sup> / <sub>4</sub> -6	1
	4.4	8	G <sup>1</sup> / <sub>4</sub>	14.4	33.2	5.6	16	9	28.9	19	44	186203	QSTF-G <sup>1</sup> / <sub>4</sub> -8	1
	4.9	10	G <sup>1</sup> / <sub>4</sub>	17.6	33.2	5.6	17.3	9	31.2	19	47	186205	QSTF-G <sup>1</sup> / <sub>4</sub> -10	1
G <sup>3</sup> / <sub>8</sub>	4.9	8	G <sup>3</sup> / <sub>8</sub>	14.4	38.1	6.6	19.2	10.5	31	24	71	186204	QSTF-G <sup>3</sup> / <sub>8</sub> -8	1
	5.8	10	G <sup>3</sup> / <sub>8</sub>	17.6	38.1	6.6	19.2	10.5	33.6	24	74	186206	QSTF-G <sup>3</sup> / <sub>8</sub> -10	1
	6	12	G <sup>3</sup> / <sub>8</sub>	21	38.1	6.6	20.9	10.5	36.4	24	77	186207	QSTF-G <sup>3</sup> / <sub>8</sub> -12	1
G <sup>1</sup> / <sub>2</sub>	7	12	G <sup>1</sup> / <sub>2</sub>	21	42.8	7.6	21.9	13	37.9	27	99	186208	QSTF-G <sup>1</sup> / <sub>2</sub> -12	1

\* 包装单位数量

# 快插/螺纹接头 QS

技术参数

FESTO

## T形快插/螺纹接头QSTL

360° 可旋转

外螺纹

带外六角

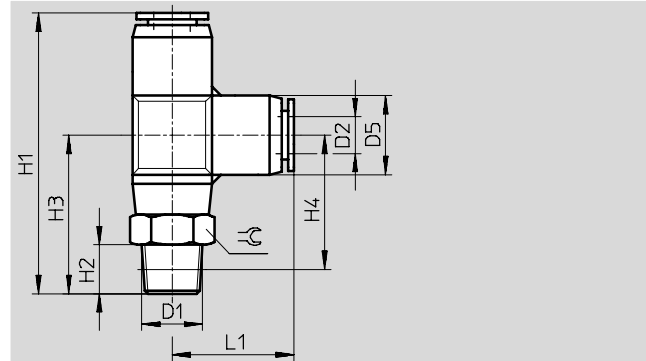

尺寸和订货数据														
接口	公称通径	气管外径	D5	H1	H2	H3	H4	L1	≈C	每件重量	订货号	型号	PU*	
D1	[mm]	D2	∅							[g]				
<b>R 螺纹</b>														
R <sup>1</sup> / <sub>8</sub>	2.6	4	10	41.5	8	24.5	20.5	17	10	14.5	153117	QSTL- <sup>1</sup> / <sub>8</sub> -4	10	
											130824	QSTL- <sup>1</sup> / <sub>8</sub> -4-100	100	
	4	6	13	46	8	26	22	20	12	17	153118	QSTL- <sup>1</sup> / <sub>8</sub> -6	10	
												130825	QSTL- <sup>1</sup> / <sub>8</sub> -6-100	100
	5	8	15	50.5	8	28.5	24	22	14	22.5	153120	QSTL- <sup>1</sup> / <sub>8</sub> -8	10	
											130826	QSTL- <sup>1</sup> / <sub>8</sub> -8-50	50	
R <sup>1</sup> / <sub>4</sub>	4	6	13	49	11	29	23	20	14	26	153119	QSTL- <sup>1</sup> / <sub>4</sub> -6	10	
											130827	QSTL- <sup>1</sup> / <sub>4</sub> -6-100	100	
	5	8	15	53.5	11	31.5	25	22	14	28.5	153121	QSTL- <sup>1</sup> / <sub>4</sub> -8	10	
												130828	QSTL- <sup>1</sup> / <sub>4</sub> -8-50	50
	6.7	10	17.5	61.5	11	36	30	25.5	17	41.5	153123	QSTL- <sup>1</sup> / <sub>4</sub> -10	10	
											130829	QSTL- <sup>1</sup> / <sub>4</sub> -10-50	50	
R <sup>3</sup> / <sub>8</sub>	5	8	15	55	12	33	26.5	22	17	41	153122	QSTL- <sup>3</sup> / <sub>8</sub> -8	10	
	6.7	10	17.5	62.5	12	37	30.5	25.5	17	50.5	153124	QSTL- <sup>3</sup> / <sub>8</sub> -10	10	
	8.7	12	21	67	12	39	32.5	28	21	62.5	153125	QSTL- <sup>3</sup> / <sub>8</sub> -12	10	
R <sup>1</sup> / <sub>2</sub>	8.7	12	21	70	15	42	34	28	21	77.5	153126	QSTL- <sup>1</sup> / <sub>2</sub> -12	1	
	10.9	16	25	84.5	15	51	41	33.5	22	99	153127	QSTL- <sup>1</sup> / <sub>2</sub> -16	1	

\* 包装单位数量

# 快插/螺纹接头 QS

技术参数

T形快插/螺纹接头QSTL

360° 可旋转

外螺纹

带外六角



G 螺纹

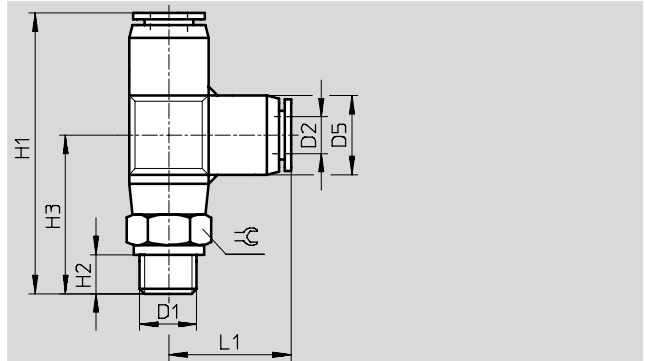

尺寸和订货数据													
接口	公称通径	气管外径	D5 Ø	H1	H2	H3	L1	≈	每件重量	订货号	型号		PU*
D1	[mm]	D2							[g]				
G 螺纹, 带密封圈													
G <sup>1</sup> / <sub>8</sub>	2.6	4	10	40.2	5.1	23.3	16.9	13	16	186168	QSTL-G <sup>1</sup> / <sub>8</sub> -4		10
										132075	QSTL-G <sup>1</sup> / <sub>8</sub> -4-100	· 新产品	100
	4	6	13	45.2	5.1	25	20.2	13	18	186169	QSTL-G <sup>1</sup> / <sub>8</sub> -6		10
										132076	QSTL-G <sup>1</sup> / <sub>8</sub> -6-100	· 新产品	100
G <sup>1</sup> / <sub>4</sub>	5	8	15	49.4	5.1	27.2	22.2	14	23	186171	QSTL-G <sup>1</sup> / <sub>8</sub> -8		10
										132077	QSTL-G <sup>1</sup> / <sub>8</sub> -8-50	· 新产品	50
	4	6	13	46.7	5.6	26.5	20.2	17	27	186170	QSTL-G <sup>1</sup> / <sub>4</sub> -6		10
										132078	QSTL-G <sup>1</sup> / <sub>4</sub> -6-100	· 新产品	100
G <sup>1</sup> / <sub>4</sub>	5	8	15	50.9	5.6	28.7	22.2	17	31	186172	QSTL-G <sup>1</sup> / <sub>4</sub> -8		10
										132079	QSTL-G <sup>1</sup> / <sub>4</sub> -8-50	· 新产品	50
	6.7	10	17.5	57.7	5.6	32.5	25.2	17	39	186174	QSTL-G <sup>1</sup> / <sub>4</sub> -10		10
										132080	QSTL-G <sup>1</sup> / <sub>4</sub> -10-50	· 新产品	50
G <sup>3</sup> / <sub>8</sub>	5	8	15	52.4	6.6	30.2	22.2	19	44	186173	QSTL-G <sup>3</sup> / <sub>8</sub> -8		10
	6.7	10	17.5	59.2	6.6	34	25.2	19	49	186175	QSTL-G <sup>3</sup> / <sub>8</sub> -10		10
	8.7	12	21	64.6	6.6	36.2	28.2	21	56	186176	QSTL-G <sup>3</sup> / <sub>8</sub> -12		10
G <sup>1</sup> / <sub>2</sub>	8.7	12	21	67.6	7.6	39.2	28.2	24	81	186177	QSTL-G <sup>1</sup> / <sub>2</sub> -12		1
	10.9	16	25	79.1	7.6	46	33.1	24	96	186178	QSTL-G <sup>1</sup> / <sub>2</sub> -16		1

\* 包装单位数量



# 快插/螺纹接头 QS

技术参数



直角快插/螺纹接头QSW  
360°可旋转  
外螺纹



R 螺纹

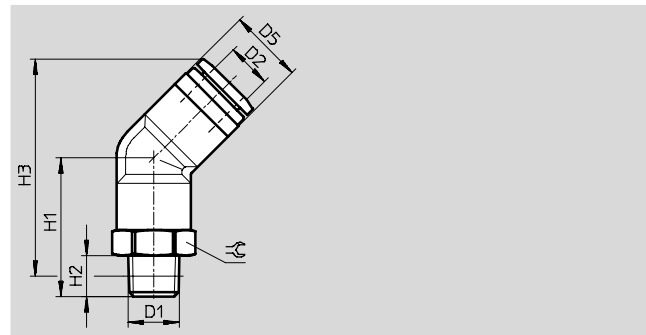

尺寸和订货数据											
接口 D1	公称通径 mm]	气管外径 D2	D5	H1	H2	H3	≈C	每件重量 [g]	订货号	型号	PU*
R 螺纹											
R $\frac{1}{8}$	2.5	4	8	14.8	8	23	10	6.1	130596	QSW- $\frac{1}{8}$ -4	10
	3.3	6	10.5	16.4	8	25.3	10	6.8	130597	QSW- $\frac{1}{8}$ -6	10
	5.3	8	14.5	27	8	42.2	14	18	130598	QSW- $\frac{1}{8}$ -8	10
R $\frac{1}{4}$	3.3	6	10.5	21.4	11	28.2	14	17.9	130599	QSW- $\frac{1}{4}$ -6	10
	5.3	8	14.5	30	11	43.2	14	24	130600	QSW- $\frac{1}{4}$ -8	10
	7	10	17.5	34.2	11	50.6	17	34	130601	QSW- $\frac{1}{4}$ -10	10
R $\frac{3}{8}$	7	10	17.5	35.2	12	51.3	17	42	130602	QSW- $\frac{3}{8}$ -10	10
	7.5	12	21	39	12	60	21	66	130603	QSW- $\frac{3}{8}$ -12	10
R $\frac{1}{2}$	7.5	12	21	42	15	61.2	21	80	130604	QSW- $\frac{1}{2}$ -12	1
	10.7	16	25	47	15	67.6	22	83	130605	QSW- $\frac{1}{2}$ -16	1

\* 包装单位数量

直角快插接头QSW...HL  
带轴套

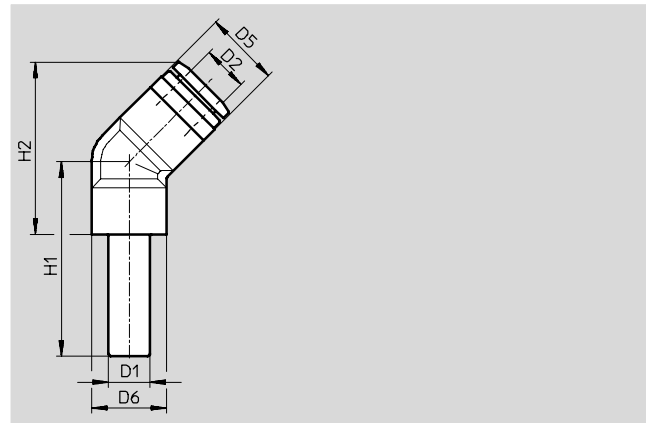

尺寸和订货数据											
轴套∅ D1	公称通径 mm]	气管外径 D2	D5	D6	H1	H2	每件重量 [g]	订货号	型号	PU*	
4	2	4	8	8	21.8	15	1.4	130617	QSW-4HL	10	
6	2.7	6	10.5	8	24.6	17.3	2.1	130618	QSW-6HL	10	
8	5	8	14.5	14.5	37.5	33.2	7.8	130619	QSW-8HL	10	
10	6	10	17.5	17.5	42.2	39.7	13	130620	QSW-10HL	10	
12	7	12	21	21	49.5	48.4	20	130621	QSW-12HL	10	

\* 包装单位数量

# 快插/螺纹接头 QS

技术参数

FESTO

## X形快插接头 QSX

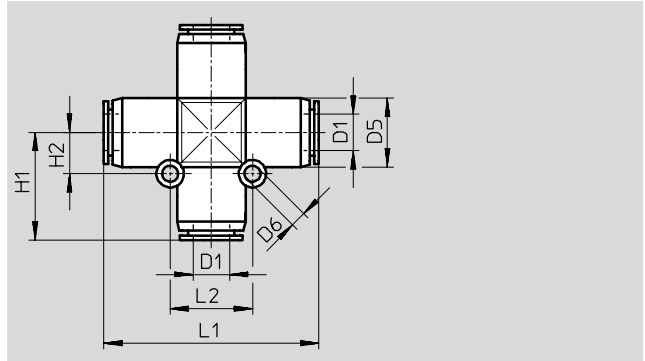

尺寸和订货数据											
气管外径	公称通径	D5 Ø	D6 Ø	H1	H2	L1	L2	每件重量	订货号	型号	PU*
D1	[mm]							[g]			
8	4.7	15	3.5	23.5	9	47	18	20	153285	QXS-8	10
10	6.1	17.5	4.5	27.5	11	55	22	32	153286	QXS-10	10
12	7.5	21	4.5	31	12	62	24	46	153287	QXS-12	10

\* 包装单位数量

# 快插/螺纹接头 QS

技术参数

## Y形快插/螺纹接头 QSY

360° 可旋转

外螺纹

带外六角



M 螺纹

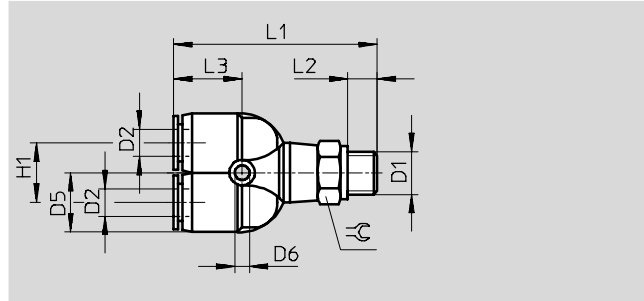

R 螺纹

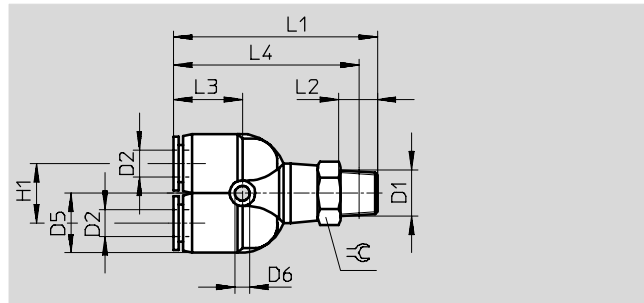

### 尺寸和订货数据

接口	公称通径	气管外径	D5 Ø	D6 Ø	H1	L1	L2	L3	L4	±C	每件重量 [g]	订货号	型号	PU*
D1	[mm]	D2												
<b>公制螺纹, 带密封圈</b>														
M5	1.4	4	10	3.4	11	38.1	3.5	14.1	-	10	12	<b>190673</b>	<b>QSY-M5-4</b>	<b>10</b>
	1.4	6	12.5	3.2	12	41.9	3.5	15.8	-	12	16	<b>190674</b>	<b>QSY-M5-6</b>	<b>10</b>
<b>R 螺纹</b>														
R <sup>1</sup> / <sub>8</sub>	2.3	4	10	3.4	11	41	8	14.5	38	10	15	<b>153138</b>	<b>QSY-<sup>1</sup>/<sub>8</sub>-4</b>	<b>10</b>
	3.6	6	13	3.2	12	44.5	8	16	40.5	12	18	<b>153139</b>	<b>QSY-<sup>1</sup>/<sub>8</sub>-6</b>	<b>10</b>
	4.6	8	15	3.2	14	49	8	17.5	45	14	23.5	<b>153141</b>	<b>QSY-<sup>1</sup>/<sub>8</sub>-8</b>	<b>10</b>
R <sup>1</sup> / <sub>4</sub>	2.3	4	10	3.4	11	43.6	11	14.1	37.6	14	23	<b>190675</b>	<b>QSY-<sup>1</sup>/<sub>4</sub>-4</b>	<b>10</b>
	3.6	6	13	3.2	12	47.5	11	16	41.5	14	25	<b>153140</b>	<b>QSY-<sup>1</sup>/<sub>4</sub>-6</b>	<b>10</b>
	4.6	8	15	3.2	14	52	11	17.5	46	14	29.5	<b>153142</b>	<b>QSY-<sup>1</sup>/<sub>4</sub>-8</b>	<b>10</b>
	6.2	10	18	4.5	18	58.5	11	20	52.5	17	43	<b>153144</b>	<b>QSY-<sup>1</sup>/<sub>4</sub>-10</b>	<b>10</b>
R <sup>3</sup> / <sub>8</sub>	4.6	8	15	3.2	14	53.5	12	17.5	47	17	42.5	<b>153143</b>	<b>QSY-<sup>3</sup>/<sub>8</sub>-8</b>	<b>10</b>
	6.2	10	18	4.5	18	59.5	12	20	53	17	51.5	<b>153145</b>	<b>QSY-<sup>3</sup>/<sub>8</sub>-10</b>	<b>10</b>
	6.9	12	21	4.5	20	64.5	12	22.5	58	21	64.5	<b>153146</b>	<b>QSY-<sup>3</sup>/<sub>8</sub>-12</b>	<b>10</b>
R <sup>1</sup> / <sub>2</sub>	6.9	12	21	4.5	20	67.5	15	22.5	59.5	21	79.5	<b>153147</b>	<b>QSY-<sup>1</sup>/<sub>2</sub>-12</b>	<b>10</b>

\* 包装单位数量

# 快插/螺纹接头 QS

技术参数



## Y形快插/螺纹接头 QSY

360° 可旋转

外螺纹

带外六角



G 螺纹

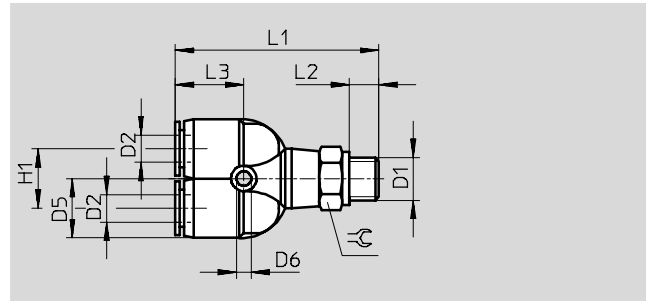

尺寸和订货数据													
接口	公称通径	气管外径	D5 ∅	D6 ∅	H1	L1	L2	L3	≈C	每件重量	订货号	型号	PU*
D1	[mm]	D2								[g]			
<b>G 螺纹, 带密封圈</b>													
G <sup>1</sup> / <sub>8</sub>	2.3	4	10	3.4	11	40.6	5.1	14.1	13	17	<b>186179</b>	<b>QSY-G<sup>1</sup>/<sub>8</sub>-4</b>	<b>10</b>
	3.6	6	12.5	3.2	12	43.4	5.1	15.8	13	18	<b>186180</b>	<b>QSY-G<sup>1</sup>/<sub>8</sub>-6</b>	<b>10</b>
	4.6	8	14.5	3.2	14	47.7	5.1	17.2	14	23	<b>186182</b>	<b>QSY-G<sup>1</sup>/<sub>8</sub>-8</b>	<b>10</b>
G <sup>1</sup> / <sub>4</sub>	3.6	6	12.5	3.2	12	44.9	5.6	15.8	17	28	<b>186181</b>	<b>QSY-G<sup>1</sup>/<sub>4</sub>-6</b>	<b>10</b>
	4.6	8	14.5	3.2	14	49.2	5.6	17.2	17	31	<b>186183</b>	<b>QSY-G<sup>1</sup>/<sub>4</sub>-8</b>	<b>10</b>
	6.2	10	18	4.5	18	54.8	5.6	19.5	17	41	<b>186185</b>	<b>QSY-G<sup>1</sup>/<sub>4</sub>-10</b>	<b>10</b>
G <sup>3</sup> / <sub>8</sub>	4.6	8	14.5	3.2	14	50.7	6.6	17.2	19	44	<b>186184</b>	<b>QSY-G<sup>3</sup>/<sub>8</sub>-8</b>	<b>10</b>
	6.2	10	18	4.5	18	56.3	6.6	19.5	19	51	<b>186186</b>	<b>QSY-G<sup>3</sup>/<sub>8</sub>-10</b>	<b>10</b>
	6.9	12	21	4.2	20	61.5	6.6	22.2	21	58	<b>186187</b>	<b>QSY-G<sup>3</sup>/<sub>8</sub>-12</b>	<b>10</b>
G <sup>1</sup> / <sub>2</sub>	6.9	12	21	4.2	20	64.5	7.6	22.2	24	84	<b>186188</b>	<b>QSY-G<sup>1</sup>/<sub>2</sub>-12</b>	<b>1</b>

\* 包装单位数量

# 快插/螺纹接头 QS

技术参数



## Y形快插接头 QSY

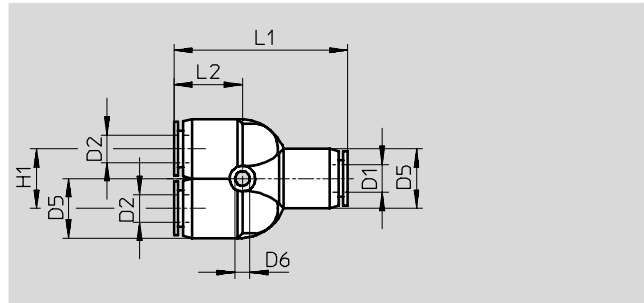

## 2 变径排气口

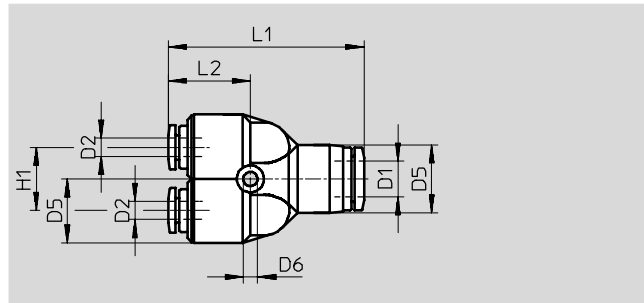

变径

### 尺寸和订货数据

气管外径 D1	公称通径 [mm]	气管外径 D2	D5 ∅	D6 ∅	H1	L1	L2	每件重量 [g]	订货号	型号	PU*
4	2.3	4	10	3.4	11	32.8	14.1	7.6	153148	QSY-4	10
									130807	QSY-4-100	100
6	3.6	6	12.5	3.4	12	37.7	15.8	11	153149	QSY-6	10
									130808	QSY-6-100	100
8	4.6	8	14.5	3.2	14	42.4	17.2	16	153150	QSY-8	10
									130809	QSY-8-50	50
10	5.9	10	18	4.5	18	48.4	19.5	26	153151	QSY-10	10
									130810	QSY-10-20	20
12	7	12	21	4.2	20	54.8	22.2	37	153152	QSY-12	10
									130811	QSY-12-20	20
16	8.5	16	25	4.5	24	62.2	22.1	45	130609	QSY-16	1
<b>变径</b>											
6	2.3	4	13	3.2	12	37.5	15	10.5	153153	QSY-6-4	10
									130812	QSY-6-4-100	100
8	2.1	4	15	3.2	14	43.3	18.2	17	130610	QSY-8-4	10
	3.6	6	15	3.2	14	42.5	17.5	14.5	153154	QSY-8-6	10
									130813	QSY-8-6-50	50
10	3.6	6	18	4.5	18	50.2	21.3	27	130611	QSY-10-6	10
	4.6	8	18	4.5	18	48.5	19.5	23	153155	QSY-10-8	10
									130814	QSY-10-8-20	20
12	5.4	8	21	4.2	20	56.4	23.8	40	130612	QSY-12-8	10
	5.9	10	21	4.5	20	55	22.5	35.5	153156	QSY-12-10	10
									130815	QSY-12-10-20	20
16	7.8	12	25	4.5	25	66.7	26.6	77	190708	QSY-16-12	1

\* 包装单位数量

# 快插/螺纹接头 QS

技术参数



Y形快插接头 QSY-...H  
带轴套

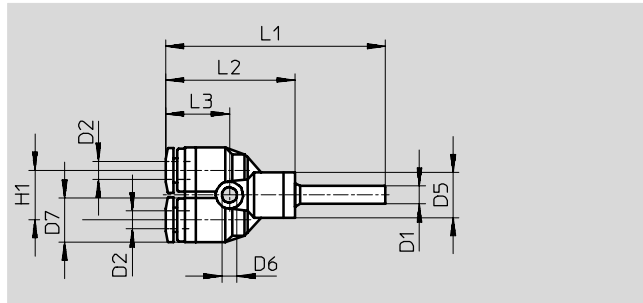

尺寸和订货数据													
轴套∅	公称通径	气管外径	D5 ∅	D6 ∅	D7 ∅	H1	L1	L2	L3	每件重量	订货号	型号	PU*
D1	[mm]	D2								[g]			
4	1.6	4	10	3.4	10	11	48.7	28.6	14.1	6.5	<b>130628</b>	<b>QSY-4H</b>	<b>10</b>
6	3.1	6	12.5	3.2	12.5	12	55.6	33	15.8	9.4	<b>130629</b>	<b>QSY-6H</b>	<b>10</b>
8	4.6	8	13	3.2	14.5	14	59.2	35.7	17.2	13	<b>130630</b>	<b>QSY-8H</b>	<b>10</b>
10	5.9	10	18	4.5	18	18	68.5	43.5	19.5	23	<b>130631</b>	<b>QSY-10H</b>	<b>10</b>
12	7.3	12	21.5	4.5	21	20	78.3	49.8	22.2	34	<b>130632</b>	<b>QSY-12H</b>	<b>10</b>
变径													
6	2.3	4	10	3.4	10	11	50.9	28.6	14.1	6.8	<b>130633</b>	<b>QSY-6H-4</b>	<b>10</b>
8	3.6	6	12.8	3.2	12.5	12	56.5	33	15.8	9.5	<b>130634</b>	<b>QSY-8H-6</b>	<b>10</b>
10	4.6	8	15	3.2	14.5	14	62.7	37.7	17.2	15	<b>130635</b>	<b>QSY-10H-8</b>	<b>10</b>
12	5.9	10	18	4.5	18	18	69.8	41.3	19.5	23	<b>130636</b>	<b>QSY-12H-10</b>	<b>10</b>

\* 包装单位数量

# 快插/螺纹接头 QS

技术参数

FESTO

## Y形快插/螺纹接头 QSYL

360° 可旋转

外螺纹

带外六角

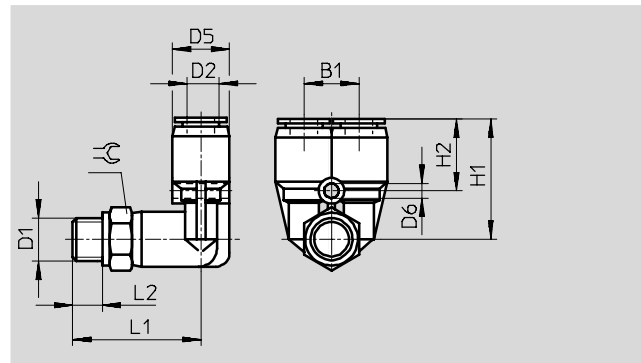
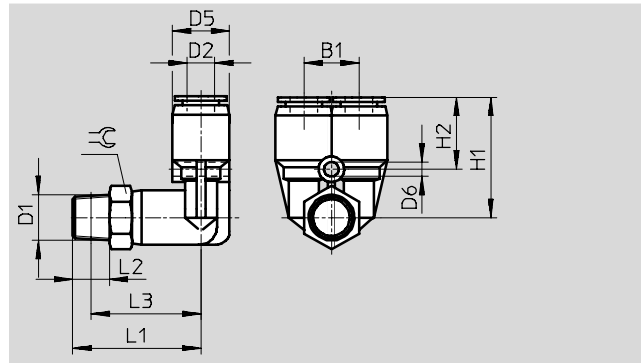

### 尺寸和订货数据

接口	公称通径	气管外径	B1	D5 ∅	D6 ∅	H1	H2	L1	L2	L3	≈	每件重量	订货号	型号	PU*	
D1	[mm]	D2										[g]				
<b>R 螺纹</b>																
R1/8	1.9	4	11	10	3.2	23	14.5	24.5	8	20.5	10	15.5	153172	QSYL-1/8-4	1	
	3	6	12	13	4.2	26.5	16	28	8	24	14	18.5	153173	QSYL-1/8-6	1	
	4.3	8	14	15	4.2	29.5	17	31	8	27	14	25	153175	QSYL-1/8-8	1	
R1/4	2.9	6	12	13	4.2	26.5	16	31	11	25	14	26.5	153174	QSYL-1/4-6	1	
	4.3	8	14	15	4.2	29.5	17	34	11	28	14	30.5	153176	QSYL-1/4-8	1	
	5.8	10	18	18	4.2	34	19	37	11	31	17	45	153178	QSYL-1/4-10	1	
R3/8	4.4	8	14	15	4.2	29.5	17	36	12	29.5	17	44	153177	QSYL-3/8-8	1	
	5.9	10	18	18	4.2	34	19	38	12	31.5	17	53.5	153179	QSYL-3/8-10	1	
	7.4	12	20	22	4.2	35.5	20.5	42	12	35.5	21	67	153180	QSYL-3/8-12	1	
R1/2	7.3	12	20	22	4.2	35.5	20.5	45	15	37	21	83	153181	QSYL-1/2-12	1	
<b>G 螺纹, 带密封圈</b>																
G1/8	1.9	4	11	10	3.2	22.7	14.2	24.7	5.1	-	13	17	186189	QSYL-G1/8-4	1	
	3	6	12	12.5	4.2	26.2	15.5	27	5.1	-	13	19	186190	QSYL-G1/8-6	1	
	4.3	8	14	14.5	4.2	29.4	16.9	30	5.1	-	14	25	186192	QSYL-G1/8-8	1	
G1/4	2.9	6	12	12.5	4.2	26.2	15.5	28.5	5.6	-	17	29	186191	QSYL-G1/4-6	1	
	4.3	8	14	14.5	4.2	29.4	16.9	31.5	5.6	-	17	33	186193	QSYL-G1/4-8	1	
	5.8	10	18	17.5	4.2	33.5	18.5	33.5	5.6	-	17	43	186195	QSYL-G1/4-10	1	
G3/8	4.4	8	14	14.5	4.2	29.4	16.9	33	6.6	-	19	46	186194	QSYL-G3/8-8	1	
	5.9	10	18	17.5	4.2	33.5	18.5	35	6.6	-	19	53	186196	QSYL-G3/8-10	1	
	7.4	12	20	21	4.2	35.2	20.4	39.2	6.6	-	21	61	186197	QSYL-G3/8-12	1	
G1/2	7.3	12	20	21	4.2	35.2	20.4	42.2	7.6	-	24	87	186198	QSYL-G1/2-12	1	

\* 包装单位数量

# 快插/螺纹接头 QS

技术参数

FESTO

## Y形快插/螺纹接头 QSYLV

360° 可旋转

外螺纹

带外六角

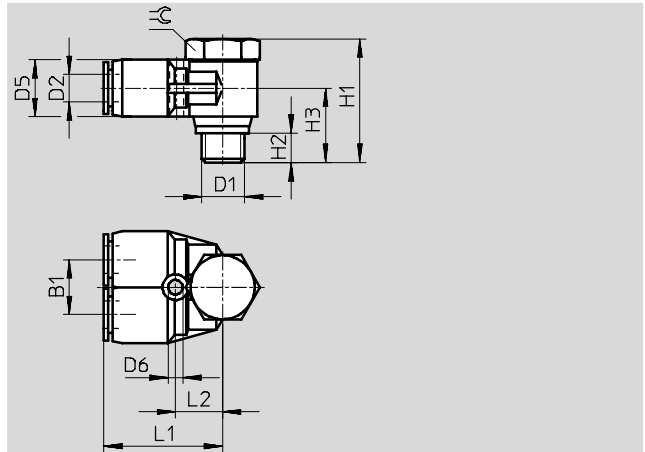
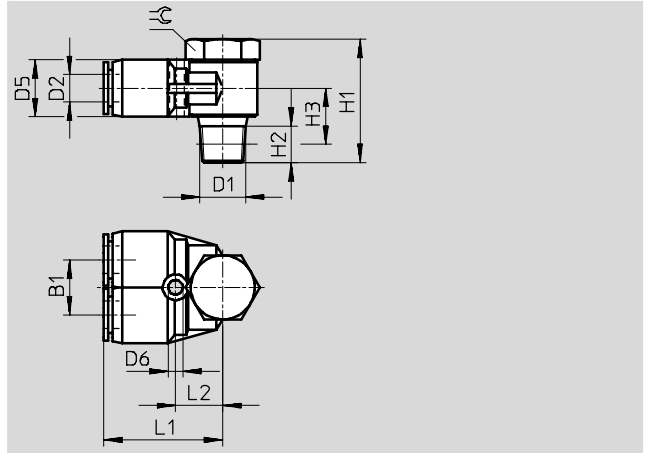

尺寸和订货数据															
接口	公称通径	气管外径	B1	D5	D6	H1	H2	H3	L1	L2	≈C	每件重量	订货号	型号	PU*
D1	[mm]	D2		∅	∅							[g]			
<b>R 螺纹</b>															
R1/8	3.3	6	12	12.5	3.2	27	8	11	26	10.5	14	24.5	153192	QSYLV-1/8-6	1
R1/4	4.4	8	14	14.5	3.2	31.5	11	12.5	29	12.5	17	41.5	153193	QSYLV-1/4-8	1
R3/8	5.7	10	17	17.5	4.2	36	12	14.5	33.5	15	21	69.5	153194	QSYLV-3/8-10	1
R1/2	7.1	12	20	21	4.2	40	15	17.5	37.5	17	24	102	153195	QSYLV-1/2-12	1
<b>G 螺纹, 带密封圈</b>															
G1/8	3.5	6	12	12.4	3.2	26.2	5.1	15.2	27.5	12	17	31	186209	QSYLV-G1/8-6	1
G1/4	4.7	8	14	14.4	3.2	28.4	5.6	16.4	30.9	14	19	48	186210	QSYLV-G1/4-8	1
G3/8	5.2	10	17	17.6	4.2	33.4	6.6	19.4	34	15.5	21	73	186211	QSYLV-G3/8-10	1
G1/2	7	12	20	21	4.2	37.4	7.6	21.9	38.9	18.5	27	123	186212	QSYLV-G1/2-12	1

\* 包装单位数量



# 快插/螺纹接头 QS

技术参数

FESTO

Y形快插/螺纹接头 QSYTF  
外螺纹和内螺纹  
带外六角



R 螺纹

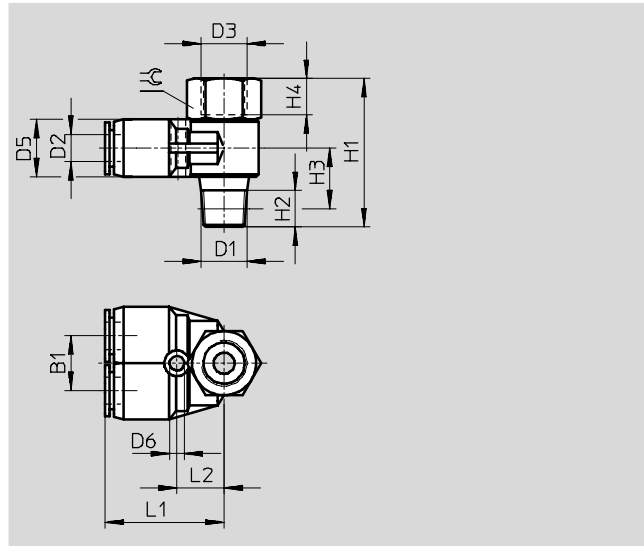

G 螺纹

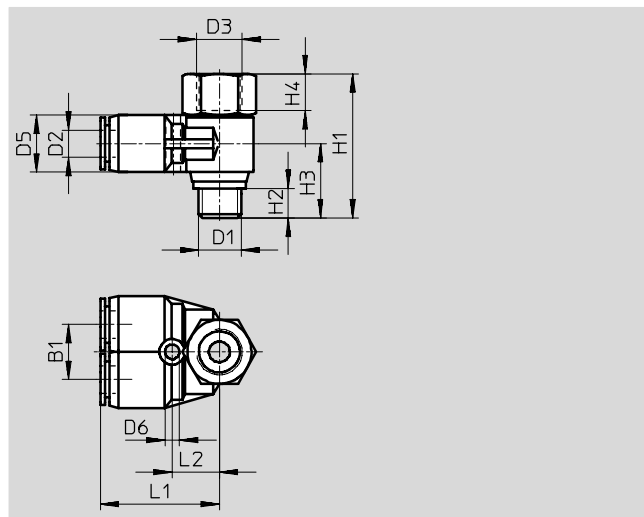

尺寸和订货数据																	
接口	公称通径	气管外径	B1	D3	D5	D6	H1	H2	H3	H4	L1	L2	≈C	每件重量	订货号	型号	PU*
D1	[mm]	D2		∅	∅	∅								[g]			
R 外螺纹和 G 内螺纹																	
R <sup>1</sup> / <sub>8</sub>	3.1	6	12	G <sup>1</sup> / <sub>8</sub>	12.4	3.5	32.5	8	12	7	26.2	10.7	14	27	153196	QSYTF- <sup>1</sup> / <sub>8</sub> -6-B	1
R <sup>1</sup> / <sub>4</sub>	4.3	8	14	G <sup>1</sup> / <sub>4</sub>	14.4	3.2	38.5	11	13.5	9	29.1	12.5	17	43	153197	QSYTF- <sup>1</sup> / <sub>4</sub> -8-B	1
R <sup>3</sup> / <sub>8</sub>	5.5	10	17	G <sup>3</sup> / <sub>8</sub>	17.6	4.2	44.5	12	15.7	11	33.5	15	21	72	153198	QSYTF- <sup>3</sup> / <sub>8</sub> -10-B	1
R <sup>1</sup> / <sub>2</sub>	6.8	12	20	G <sup>1</sup> / <sub>2</sub>	21	4.2	52.2	13	16.5	14	37.4	17	24	109	153199	QSYTF- <sup>1</sup> / <sub>2</sub> -12-B	1
G 外螺纹, 带密封圈																	
G <sup>1</sup> / <sub>8</sub>	3.1	6	12	G <sup>1</sup> / <sub>8</sub>	12.4	3.2	29.2	5.1	15.2	7	27.5	12	17	32	186213	QSYTF-G <sup>1</sup> / <sub>8</sub> -6	1
G <sup>1</sup> / <sub>4</sub>	4.3	8	14	G <sup>1</sup> / <sub>4</sub>	14.4	3.2	32.9	5.6	16.4	9	30.9	14	19	47	186214	QSYTF-G <sup>1</sup> / <sub>4</sub> -8	1
G <sup>3</sup> / <sub>8</sub>	5.5	10	17	G <sup>3</sup> / <sub>8</sub>	17.6	4.2	41.4	6.6	19.4	11	34	15.5	21	72	186215	QSYTF-G <sup>3</sup> / <sub>8</sub> -10	1
G <sup>1</sup> / <sub>2</sub>	6.8	12	20	G <sup>1</sup> / <sub>2</sub>	21	4.2	47.4	7.6	21.9	14	38.9	18.5	27	127	186216	QSYTF-G <sup>1</sup> / <sub>2</sub> -12	1

\* 包装单位数量

# 快插/螺纹接头 QSM-B, mini

技术参数

## 快插/螺纹接头 QSM-B

外螺纹  
带外六角



M 螺纹

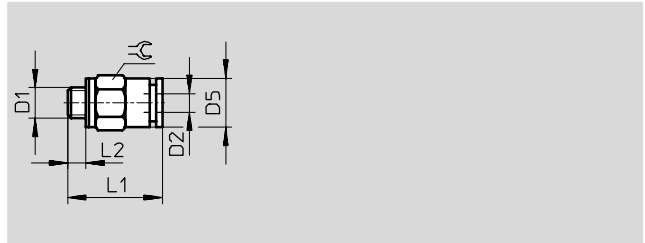

R 螺纹

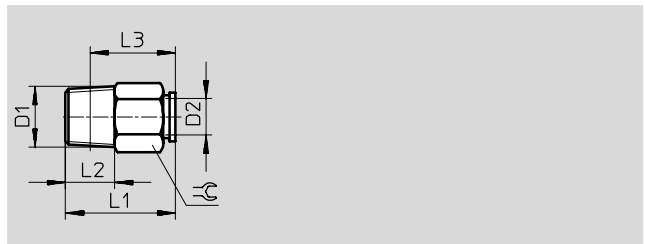

尺寸和订货数据											
接口	公称通径	气管外径	D5	L1	L2	L3	⌀	每件重量	订货号	型号	PU*
D1	[mm]	D2	∅					[g]			
公制螺纹, 带密封圈											
M3	0.9	3	6.0	13.3	2.5	-	5.5	1.1	132102	QSM-B-M3-3-20	新产品 20
	1.1	4	7.8	15.7	2.5	-	8	2.4	130894	QSM-B-M3-4-20	20
M5	2.0	3	7.8	16.2	3	-	8	3.5	132103	QSM-B-M5-3-20	新产品 20
	2.2	4	7.8	16.2	3	-	8	3.2	130895	QSM-B-M5-4-20	20
	2.1	6	9.8	17.3	3	-	10	4.5	130896	QSM-B-M5-6-20	20
R 螺纹											
R <sup>1</sup> / <sub>8</sub>	2.9	4	7.8	16.2	8	12.3	10	6	132104	QSM-B- <sup>1</sup> / <sub>8</sub> -4-20	新产品 20
	4.5	6	9.8	17.9	8	14	10	6	132105	QSM-B- <sup>1</sup> / <sub>8</sub> -6-20	新产品 20

\* 包装单位数量

# 快插/螺纹接头 QSM-B, mini

技术参数

## 快插/螺纹接头 QSM-B-...-I

外螺纹

带内六角



M 螺纹

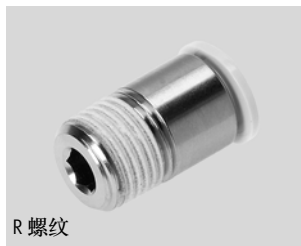
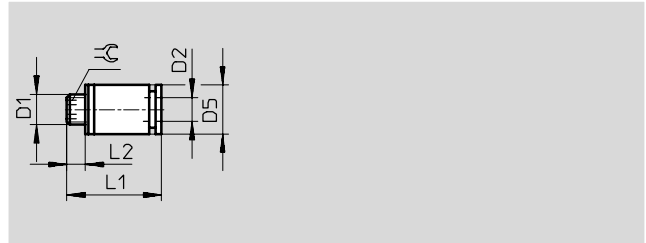

R 螺纹

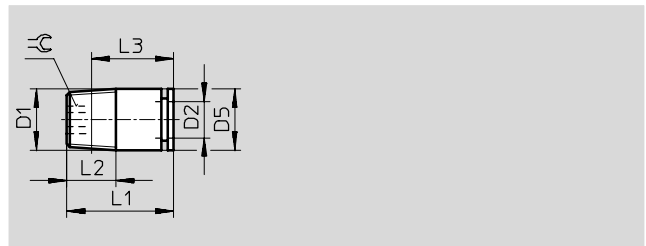

### 尺寸和订货数据

接口	公称通径	气管外径	D5	L1	L2	L3	⊕	每件重量	订货号	型号	PU*	
D1	[mm]	D2	∅					[g]				
公制螺纹, 带密封圈												
M3	1.6	3	8	15.7	2.5	-	1.5	2.3	132116	QSM-B-M3-3-I-20	· 新产品	20
	1.5	4	8	15.7	2.5	-	1.5	2.2	130909	QSM-B-M3-4-I-20		20
M5	1.9	3	8	16.2	3.0	-	2.0	3.3	132117	QSM-B-M5-3-I-20	· 新产品	20
	2.5	4	8	16.2	3.0	-	2.5	3	130910	QSM-B-M5-4-I-20		20
	2.6	6	9.8	17.8	3.0	-	2.5	4.4	130911	QSM-B-M5-6-I-20		20
M7	2.3	4	9.8	18.9	5.5	-	3.0	6	130912	QSM-B-M7-4-I-20		20
	2.9	6	9.8	20.9	5.5	-	4.0	6.4	130913	QSM-B-M7-6-I-20		20
R 螺纹												
R1/8	3.1	4	10	16.4	8.0	12.5	3.0	6	132118	QSM-B-1/8-4-I-20	· 新产品	20
	4.1	6	10	18.2	8.0	14.3	4.0	6	132119	QSM-B-1/8-6-I-20	· 新产品	20

\* 包装单位数量

# 快插/螺纹接头 QSM-B, mini

技术参数

## L形快插/螺纹接头QSML-B

360°可旋转

外螺纹

带外六角

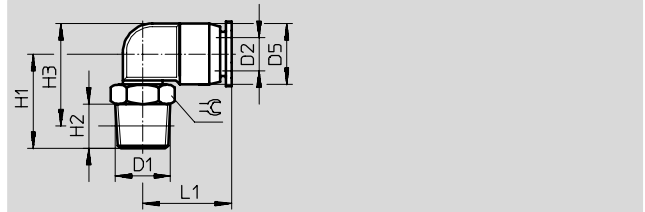
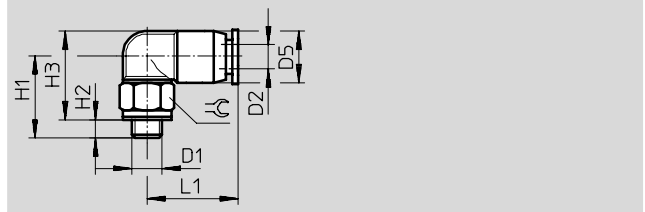

尺寸和订货数据												
接口	公称通径	气管外径	D5 ∅	H1	H2	H3	L1	≈	每件重量	订货号	型号	PU*
D1	[mm]	D2							[g]			
公制螺纹, 带密封圈												
M3	0.8	3	6	12	3.3	12.5	11	5.5	1.5	132106	QSML-B-M3-3-20	新产品 20
	1.3	4	8	14	2.5	15.5	15.7	8	3	130899	QSML-B-M3-4-20	20
M5	1.5	3	6	13.5	3.5	13.5	11	8	2.8	132107	QSML-B-M5-3-20	新产品 20
	1.7	4	8	13.5	3	14.5	15.7	8	3.4	130900	QSML-B-M5-4-20	20
	2.1	6	10.5	14.5	3	16.8	16.3	8	4.1	130901	QSML-B-M5-6-20	20
M7	2.0	4	8	17	5.5	15.5	15.7	10	5.6	132108	QSML-B-M7-4-20	新产品 20
	2.4	6	10.5	18	5.5	17.5	16.3	10	6.2	132109	QSML-B-M7-6-20	新产品 20
R 螺纹												
R1/8	2.5	4	8	16	8	16.3	15.7	10	6	132110	QSML-B-1/8-4-20	新产品 20
	3.3	6	10.5	17	8	18.8	16.3	10	7	132111	QSML-B-1/8-6-20	新产品 20

\* 包装单位数量

# 快插/螺纹接头 QSM-B, mini

技术参数

FESTO

## T形快插/螺纹接头QSMT-B

360°可旋转

外螺纹

带外六角

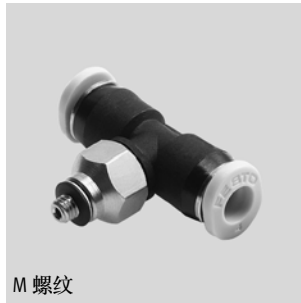

M 螺纹

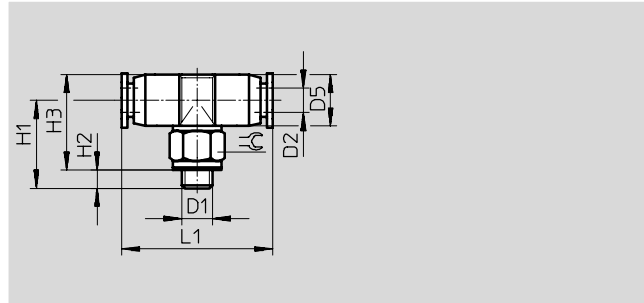

R 螺纹

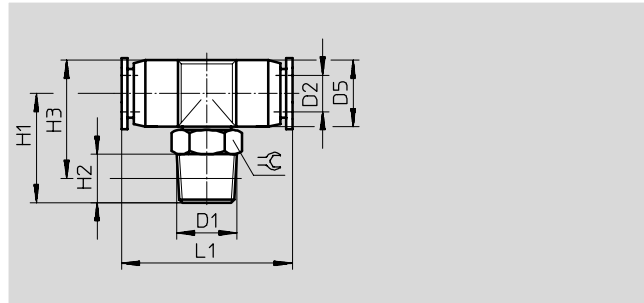

### 尺寸和订货数据

接口	公称通径	气管外径	D5	H1	H2	H3	L1	≈	每件重量	订货号	型号	PU*
D1	[mm]	D2	∅						[g]			
公制螺纹, 带密封圈												
M3	0.9	3	6	12	3.3	12.5	22	5.5	2	132112	QSMT-B-M3-3-20	· 新产品 20
	1.3	4	8	15	2.5	15.5	26.2	8	3.9	130904	QSMT-B-M3-4-20	20
M5	1.6	3	6	13.5	3	13.5	22	8	3.3	132113	QSMT-B-M5-3-20	· 新产品 20
	2.2	4	8	14.5	3	14.5	26.2	8	4.3	130905	QSMT-B-M5-4-20	20
	2.1	6	10.5	15.5	3	17.8	28.4	8	5.6	130906	QSMT-B-M5-6-20	20
R 螺纹												
R <sup>1</sup> / <sub>8</sub>	2.4	4	8	17	8	17.1	26.2	10	7	132114	QSMT-B- <sup>1</sup> / <sub>8</sub> -4-20	· 新产品 20
	3.3	6	10.5	18	8	19.3	28.4	10	8	132115	QSMT-B- <sup>1</sup> / <sub>8</sub> -6-20	· 新产品 20

\* 包装单位数量

# 快插/螺纹接头 QS-B

技术参数



## 快插/螺纹接头 QS-B

外螺纹  
带外六角



R 螺纹

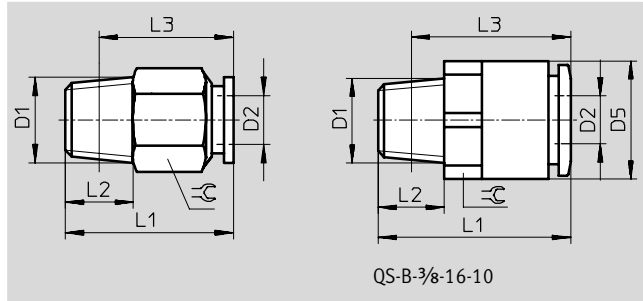

QS-B-3/8-16-10

尺寸和订货数据											
接口	公称通径	气管外径	D5	L1	L2	L3	≈C	每件重量	订货号	型号	PU*
D1	[mm]	D2						[g]			
R 螺纹											
R <sup>1</sup> / <sub>8</sub>	2.6	4	-	21	8	17	10	8.3	130914	QS-B-1/8-4-20	20
	4	6	-	22.6	8	18.6	12	9.3	130915	QS-B-1/8-6-20	20
	5	8	-	27.9	8	23.9	14	16	130916	QS-B-1/8-8-20	20
	5.4	10	-	30.3	8	26.4	17	22.5	132120	QS-B-x-10-20	新产品 20
R <sup>1</sup> / <sub>4</sub>	2.6	4	-	21	11	15	14	16	130917	QS-B-1/4-4-20	20
	4	6	-	24.6	11	18.5	14	18	130918	QS-B-1/4-6-20	20
	5	8	-	26.6	11	20.6	14	16	130919	QS-B-1/4-8-20	20
	6.7	10	-	29.8	11	23.8	17	20	132121	QS-B-1/4-10-20	新产品 20
	8.7	12	-	35.9	11	29.9	21	43.7	132122	QS-B-1/4-12-20	新产品 20
R <sup>3</sup> / <sub>8</sub>	4	6	-	23.6	12	17.2	17	28	130920	QS-B-3/8-6-10	10
	5	8	-	23.9	12	17.6	17	24	130921	QS-B-3/8-8-10	10
	6.7	10	-	29.3	12	23	17	27	130922	QS-B-3/8-10-10	10
	8.7	12	-	31.9	12	25.6	21	35.5	132123	QS-B-3/8-12-10	新产品 10
	10.3	16	23.8	41.9	12	34.8	22	59.5	132124	QS-B-3/8-16-10	新产品 10
R <sup>1</sup> / <sub>2</sub>	6.7	10	-	30.3	15	22.1	21	50	130924	QS-B-1/2-10-10	10
	8.7	12	-	33.9	15	25.7	21	50	130925	QS-B-1/2-12-10	10
	12	16	-	41.3	15	33.2	24	67	132125	QS-B-1/2-16-10	新产品 10

\* 包装单位数量

# 快插/螺纹接头 QS-B

技术参数

## 快插/螺纹接头 QS-B-...-I

外螺纹  
带内六角

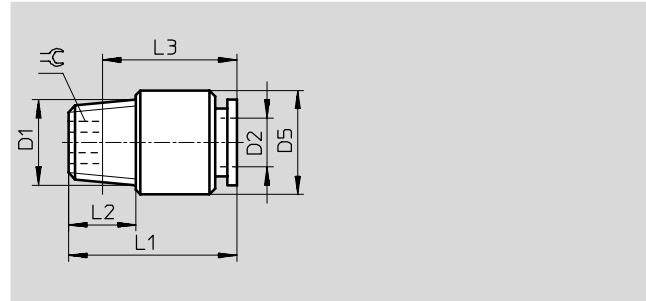

尺寸和订货数据											
接口	公称通径	气管外径	D5	L1	L2	L3	≡C	每件重量	订货号	型号	PU*
D1	[mm]	D2	∅					[g]			
R 螺纹											
R <sup>1</sup> / <sub>8</sub>	2.1	4	9.7	21	8	17	2.5	7.6	130990	QS-B- <sup>1</sup> / <sub>8</sub> -4-I-20	20
	3.7	6	11.8	22.6	8	18.6	4	8.1	130991	QS-B- <sup>1</sup> / <sub>8</sub> -6-I-20	20
	4.7	8	13.7	27.9	8	23.9	5	14	130992	QS-B- <sup>1</sup> / <sub>8</sub> -8-I-20	20
	5	10	17.7	30.3	8	26.4	5	25	132151	QS-B- <sup>1</sup> / <sub>8</sub> -10-I-20	· 新产品 20
R <sup>1</sup> / <sub>4</sub>	3.7	6	14	22.6	11	16.5	4	15	130994	QS-B- <sup>1</sup> / <sub>4</sub> -6-I-20	20
	5	8	14	26.6	11	20.6	6	15	130995	QS-B- <sup>1</sup> / <sub>4</sub> -8-I-20	20
	5	10	17.7	29.8	11	23.8	7	22	132152	QS-B- <sup>1</sup> / <sub>4</sub> -10-I-20	· 新产品 20
	6.8	12	20.8	35.9	11	29.9	6	40	132153	QS-B- <sup>1</sup> / <sub>4</sub> -12-I-20	· 新产品 20
R <sup>3</sup> / <sub>8</sub>	5	8	16.8	23.9	12	17.6	6	23	130997	QS-B- <sup>3</sup> / <sub>8</sub> -8-I-10	10
	5	10	17.8	29.3	12	23	6	28	130998	QS-B- <sup>3</sup> / <sub>8</sub> -10-I-10	10
	7.1	12	20.8	31.9	12	25.6	8	33.5	132154	QS-B- <sup>3</sup> / <sub>8</sub> -12-I-10	· 新产品 10
R <sup>1</sup> / <sub>2</sub>	5	10	20.8	30.3	15	22.1	6	49	132000	QS-B- <sup>1</sup> / <sub>2</sub> -10-I-10	10
	7.1	12	20.8	33.9	15	25.7	8	49	132001	QS-B- <sup>1</sup> / <sub>2</sub> -12-I-10	10

\* 包装单位数量

## 快插/螺纹接头 QS-B

技术参数

FESTO

### 快插接头QS-B

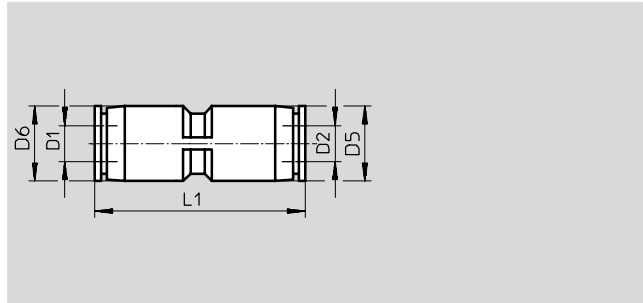

尺寸和订货数据									
气管外径	公称通径	气管外径	D5	D6	L1	每件重量	订货号	型号	PU*
D1	[mm]	D2	∅			[g]			
4	2.6	4	10	-	30.8	4.7	130964	QS-B-4-20	20
6	4	6	12.5	-	34.9	6.5	130965	QS-B-6-20	20
8	5	8	14.5	-	37.8	9.4	130966	QS-B-8-20	20
10	6.7	10	17.5	-	43.4	16	130967	QS-B-10-10	10
12	8.7	12	21	-	47.8	22	130968	QS-B-12-10	10
16	13.7	16	25	-	49.4	25	132144	QS-B-16-10	10
变径									
6	2.6	4	12.5	12.5	34.4	6.4	130969	QS-B-6-4-20	20
8	2.3	4	10.7	14.5	38.8	7.2	132145	QS-B-8-4-20	20
	4	6	14.5	14.5	37.9	8.8	130970	QS-B-8-6-20	20
10	3.7	6	13	17.5	39.8	12	132146	QS-B-10-6-20	20
	5	8	17.5	17.5	43.1	14	130971	QS-B-10-8-20	20
12	5.2	8	14.5	21	44	16	132147	QS-B-12-8-10	10
	6.7	10	21	21	47.6	21	130972	QS-B-12-10-10	10

\* 包装单位数量



# 快插/螺纹接头 QS-B

技术参数

## L形快插/螺纹接头 QSL-B

360°可旋转

外螺纹

带外六角

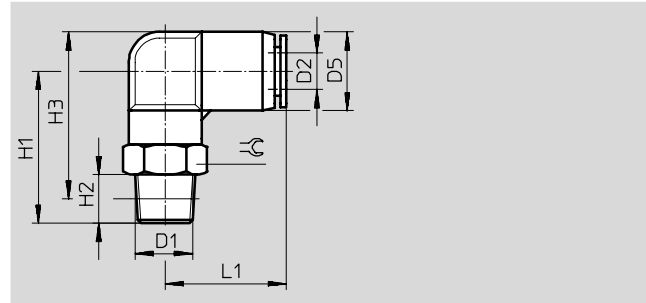

尺寸和订货数据												
接口	公称通径	气管外径	D5 ∅	H1	H2	H3	L1	≈	每件重量	订货号	型号	PU*
D1	[mm]	D2							[g]			
R 螺纹												
R <sup>1</sup> / <sub>8</sub>	2.2	4	10	18.9	8	19.9	16.8	10	6.9	130926	QSL-B- <sup>1</sup> / <sub>8</sub> -4-20	20
	3.2	6	12.5	19.5	8	21.8	19.7	10	7.8	130927	QSL-B- <sup>1</sup> / <sub>8</sub> -6-20	20
	4.6	8	14.5	24.2	8	27.5	21.9	12	12	130928	QSL-B- <sup>1</sup> / <sub>8</sub> -8-20	20
	4.5	10	17.5	26.1	8	30.9	25	12	16	132126	QSL-B- <sup>1</sup> / <sub>8</sub> -10-20	· 新产品 20
R <sup>1</sup> / <sub>4</sub>	2.2	4	10	24.4	11	23.4	16.8	14	14	130929	QSL-B- <sup>1</sup> / <sub>4</sub> -4-20	20
	3.4	6	12.5	26	11	26.2	19.7	14	15	130930	QSL-B- <sup>1</sup> / <sub>4</sub> -6-20	20
	4.8	8	14.5	27.2	11	28.4	21.9	14	16	130931	QSL-B- <sup>1</sup> / <sub>4</sub> -8-20	20
	6.0	10	17.5	28.1	11	30.8	25	14	20	132127	QSL-B- <sup>1</sup> / <sub>4</sub> -10-20	· 新产品 20
	5.8	12	21	29.8	11	34.3	29.2	14	24	132128	QSL-B- <sup>1</sup> / <sub>4</sub> -12-20	· 新产品 20
R <sup>3</sup> / <sub>8</sub>	3.3	6	12.5	26.5	12	26.4	19.7	17	21	130932	QSL-B- <sup>3</sup> / <sub>8</sub> -6-10	10
	4.8	8	14.5	27.7	12	28.6	21.9	17	23	130933	QSL-B- <sup>3</sup> / <sub>8</sub> -8-10	10
	6.4	10	17.5	29.6	12	32	25	17	26	130934	QSL-B- <sup>3</sup> / <sub>8</sub> -10-10	10
	6.6	12	21	31.3	12	35.5	29.2	17	30	132129	QSL-B- <sup>3</sup> / <sub>8</sub> -12-10	· 新产品 10
	10.1	16	25	47	11	53.2	33.1	22	81.5	132130	QSL-B- <sup>3</sup> / <sub>8</sub> -16-10	· 新产品 10
R <sup>1</sup> / <sub>2</sub>	6.2	10	17.5	32.6	15	33.2	25	21	42	130936	QSL-B- <sup>1</sup> / <sub>2</sub> -10-10	10
	7.1	12	21	34.3	15	36.6	29.2	21	46	130937	QSL-B- <sup>1</sup> / <sub>2</sub> -12-10	10
	10.9	16	25	51	15	55.4	33.1	22	85.5	132131	QSL-B- <sup>1</sup> / <sub>2</sub> -16-10	· 新产品 10

\* 包装单位数量

## 快插/螺纹接头 QS-B

技术参数

FESTO

### 加长 L形快插/螺纹接头 QSLL-B

360° 可旋转

外螺纹

带外六角



R 螺纹

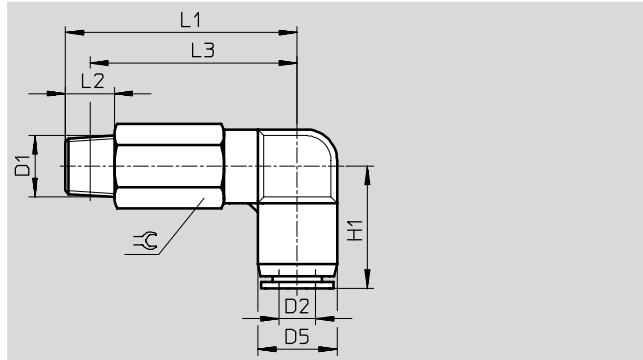

尺寸和订货数据												
接口	公称通径	气管外径	D5 ∅	H1	L1	L2	L3	≈	每件重量	订货号	型号	PU*
D1	[mm]	D2							[g]			
R 螺纹												
R <sup>1</sup> / <sub>8</sub>	2.2	4	10	16.8	31.7	8	32.7	10	12	132002	QSLL-B- <sup>1</sup> / <sub>8</sub> -4-20	20
	3.3	6	12.5	19.7	34.8	8	37.1	10	13	132003	QSLL-B- <sup>1</sup> / <sub>8</sub> -6-20	20
	4.3	8	14.5	21.9	41.5	8	44.8	12	19	132004	QSLL-B- <sup>1</sup> / <sub>8</sub> -8-20	20
R <sup>1</sup> / <sub>4</sub>	2.2	4	10	16.8	38.1	11	37.1	14	24	132155	QSLL-B- <sup>1</sup> / <sub>4</sub> -4-20	新产品 20
	3.3	6	12.5	19.7	42.2	11	42.4	14	25	132006	QSLL-B- <sup>1</sup> / <sub>4</sub> -6-20	20
	4.9	8	14.5	21.9	45.4	11	46.6	14	27	132007	QSLL-B- <sup>1</sup> / <sub>4</sub> -8-20	20
	5.9	10	17.5	25.0	49.3	11	52.0	14	30	132156	QSLL-B- <sup>1</sup> / <sub>4</sub> -10-20	新产品 20
R <sup>3</sup> / <sub>8</sub>	3.3	6	12.5	19.7	42.7	12	42.6	17	37	132008	QSLL-B- <sup>3</sup> / <sub>8</sub> -6-10	10
	4.9	8	14.5	21.9	45.9	12	46.8	17	39	132009	QSLL-B- <sup>3</sup> / <sub>8</sub> -8-10	10
	6.0	10	17.5	25.0	50.8	12	53.2	17	43	132010	QSLL-B- <sup>3</sup> / <sub>8</sub> -10-10	10
	6.3	12	21	29.2	56.0	12	60.2	17	47	132157	QSLL-B- <sup>3</sup> / <sub>8</sub> -12-10	新产品 10
R <sup>1</sup> / <sub>2</sub>	6.0	10	17.5	25.0	54.7	15	55.3	21	74	132012	QSLL-B- <sup>1</sup> / <sub>2</sub> -10-10	10
	7.0	12	21	29.2	59.9	15	62.2	21	78	132013	QSLL-B- <sup>1</sup> / <sub>2</sub> -12-10	10

\* 包装单位数量

### L形快插接头 QSL-B

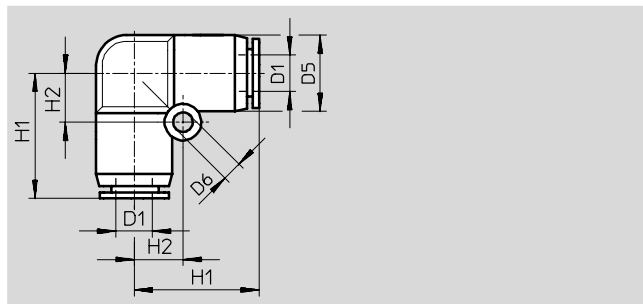

尺寸和订货数据									
气管外径	公称通径	D5 ∅	D6 ∅	H1	H2	每件重量	订货号	型号	PU*
D1	[mm]					[g]			
4	2.3	10	3.2	16.9	6.5	5.1	130950	QSL-B-4-20	20
6	3.6	12.5	3.2	20.1	8	7.3	130951	QSL-B-6-20	20
8	4.6	15	4.2	22.4	10	11	130952	QSL-B-8-20	20
10	6.2	17.5	4.2	26.2	12	17	130953	QSL-B-10-10	10
12	7.7	21	4.2	29.4	14	25	130954	QSL-B-12-10	10
16	10.8	25	4.2	33.1	12	30	132138	QSL-B-16-10	新产品 10

\* 包装单位数量

# 快插/螺纹接头 QS-B

技术参数

## T形快插/螺纹接头 QST-B

360° 可旋转

外螺纹

带外六角

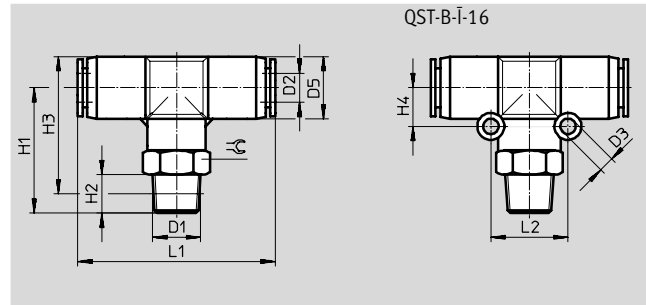

尺寸和订货数据																
接口	公称通径	气管外径	D3	D5 ∅	H1	H2	H3	H4	L1	L2	≈C	每件重量	订货号	型号	PU*	
D1	[mm]	D2										[g]				
<b>R 螺纹</b>																
R <sup>1</sup> / <sub>8</sub>	2.1	4	-	10	18.9	8	19.9	-	33.6	-	10	10	130938	QST-B- <sup>1</sup> / <sub>8</sub> -4-20	20	
	3.2	6	-	12.5	21.8	8	19.5	-	39.3	-	10	11	130939	QST-B- <sup>1</sup> / <sub>8</sub> -6-20	20	
	4.6	8	-	14.5	24.2	8	27.5	-	43.8	-	12	17	130940	QST-B- <sup>1</sup> / <sub>8</sub> -8-20	20	
	4.9	10	-	17.5	26.1	8	30.9	-	50.0	-	12	23	132132	QST-B- <sup>1</sup> / <sub>8</sub> -10-20	· 新产品	20
R <sup>1</sup> / <sub>4</sub>	2.2	4	-	10	24.4	11	23.4	-	33.6	-	14	16	130941	QST-B- <sup>1</sup> / <sub>4</sub> -4-20	20	
	3.3	6	-	12.5	26.0	11	26.2	-	39.3	-	14	18	130942	QST-B- <sup>1</sup> / <sub>4</sub> -6-20	20	
	4.9	8	-	14.5	27.2	11	28.4	-	43.8	-	14	21	130943	QST-B- <sup>1</sup> / <sub>4</sub> -8-20	20	
	5.9	10	-	17.5	28.1	11	30.8	-	50.0	-	14	27	132133	QST-B- <sup>1</sup> / <sub>4</sub> -10-20	· 新产品	20
	5.9	12	-	21	29.8	11	34.3	-	58.4	-	14	34	132134	QST-B- <sup>1</sup> / <sub>4</sub> -12-20	· 新产品	20
R <sup>3</sup> / <sub>8</sub>	3.3	6	-	12.5	26.5	12	26.4	-	39.3	-	17	25	130944	QST-B- <sup>3</sup> / <sub>8</sub> -6-10	10	
	4.8	8	-	14.5	27.7	12	28.6	-	43.8	-	17	27	130945	QST-B- <sup>3</sup> / <sub>8</sub> -8-10	10	
	6.2	10	-	17.5	29.6	12	32.0	-	50.0	-	17	34	130946	QST-B- <sup>3</sup> / <sub>8</sub> -10-10	10	
	6.7	12	-	21	31.3	12	35.5	-	58.4	-	17	41	132135	QST-B- <sup>3</sup> / <sub>8</sub> -12-10	· 新产品	10
	10.1	16	4.2	25	47	11	53.2	12	66.2	24	22	95	132136	QST-B- <sup>3</sup> / <sub>8</sub> -16-10	· 新产品	10
R <sup>1</sup> / <sub>2</sub>	6.3	10	-	17.5	32.6	15	33.2	-	50.0	-	21	50	130948	QST-B- <sup>1</sup> / <sub>2</sub> -10-10	10	
	7.1	12	-	21	34.3	15	36.6	-	58.4	-	21	57	130949	QST-B- <sup>1</sup> / <sub>2</sub> -12-10	10	
	11.2	16	4.2	25	51	15	55.4	12	66.2	24	22	99	132137	QST-B- <sup>1</sup> / <sub>2</sub> -16-10	· 新产品	10

\* 包装单位数量

# 快插/螺纹接头 QS-B

技术参数

## T形快插接头 QST-B

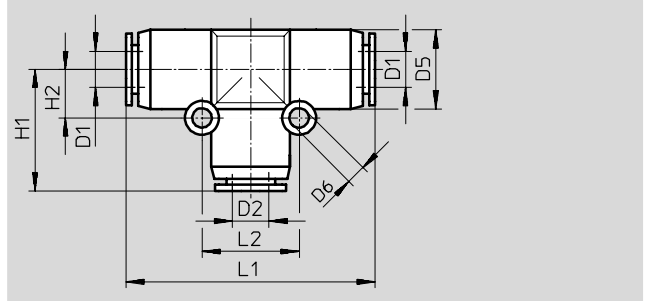

尺寸和订货数据												
气管外径	公称通径	气管外径	D5 ∅	D6 ∅	H1	H2	L1	L2	每件重量	订货号	型号	PU*
D1	[mm]	D2							[g]			
4	2.6	4	10	3.2	16.9	6.5	33.8	13	7.5	130973	QST-B-4-20	20
6	4	6	13	3.5	20.1	8	40.1	16	11	130974	QST-B-6-20	20
8	5	8	15	3.5	22.2	9	44.4	18	16	130975	QST-B-8-20	20
10	6.7	10	17.5	4.2	25.2	12	50.4	24	25	130976	QST-B-10-10	10
12	8.7	12	21	4.2	28.2	14	56.8	28	36	130977	QST-B-12-10	10
16	10.7	16	25	4.2	33.1	12	66.2	24	43.5	132148	QST-B-16-10	10

\* 包装单位数量

# 快插/螺纹接头 QS-B

技术参数

## T形快插/螺纹接头 QSTL-B

360° 可旋转

外螺纹

带外六角

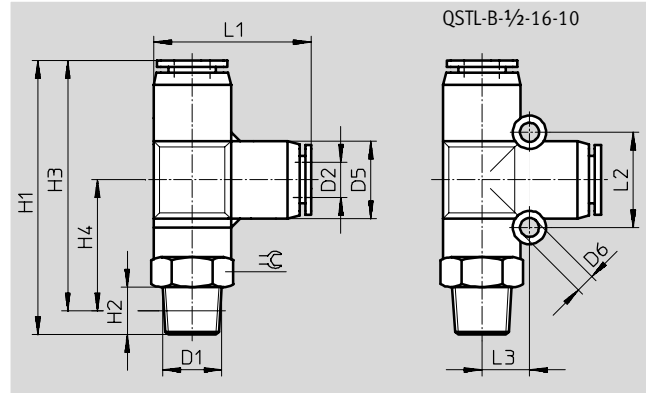

尺寸和订货数据															
接口	公称通径	气管外径	D5 ∅	H1	H2	H3	H4	L1	L2	L3	≈	每件重量	订货号	型号	PU*
D1	[mm]	D2										[g]			
<b>R 螺纹</b>															
R <sup>1</sup> / <sub>8</sub>	2.2	4	10	36.1	8	32.1	14.9	16.8	-	-	10	10	130978	QSTL-B- <sup>1</sup> / <sub>8</sub> -4-20	20
	3.4	6	12.5	40.0	8	36.0	15.5	19.7	-	-	10	11	130979	QSTL-B- <sup>1</sup> / <sub>8</sub> -6-20	20
	4.7	8	14.5	46.6	8	42.6	20.2	21.9	-	-	14	17	130980	QSTL-B- <sup>1</sup> / <sub>8</sub> -8-20	20
R <sup>1</sup> / <sub>4</sub>	2.0	4	10	41.6	11	35.6	18.4	16.8	-	-	14	16	130981	QSTL-B- <sup>1</sup> / <sub>4</sub> -4-20	20
	3.4	6	12.5	46.5	11	40.4	20.0	19.7	-	-	14	18	130982	QSTL-B- <sup>1</sup> / <sub>4</sub> -6-20	20
	4.7	8	14.5	49.6	11	43.6	21.2	21.9	-	-	14	21	130983	QSTL-B- <sup>1</sup> / <sub>4</sub> -8-20	20
R <sup>3</sup> / <sub>8</sub>	3.4	6	12.5	47.0	12	40.6	20.2	19.7	-	-	17	24	130984	QSTL-B- <sup>3</sup> / <sub>8</sub> -6-10	10
	4.7	8	14.5	50.1	12	43.8	21.4	21.9	-	-	17	27	130985	QSTL-B- <sup>3</sup> / <sub>8</sub> -8-10	10
	5.9	10	17.5	55.1	12	48.8	23.3	25.0	-	-	17	34	130986	QSTL-B- <sup>3</sup> / <sub>8</sub> -10-10	10
	6.5	12	21	61.4	12	55.1	25.0	29.2	-	-	17	41	132149	QSTL-B- <sup>3</sup> / <sub>8</sub> -12-10	● 新产品 10
R <sup>1</sup> / <sub>2</sub>	5.9	10	17.5	58.1	15	49.9	24.4	25.2	-	-	21	50	130988	QSTL-B- <sup>1</sup> / <sub>2</sub> -10-10	10
	6.8	12	21	64.4	15	56.2	26.1	29.2	-	-	21	57	130989	QSTL-B- <sup>1</sup> / <sub>2</sub> -12-10	10
	10.9	16	25	84.1	15	76.0	42.9	33.1	24	12	22	99	132150	QSTL-B- <sup>1</sup> / <sub>2</sub> -16-10	● 新产品 10

\* 包装单位数量

# 快插/螺纹接头 QS-B

技术参数

## Y形快插/螺纹接头 QSY-B

360°可旋转

外螺纹

带外六角



M 螺纹

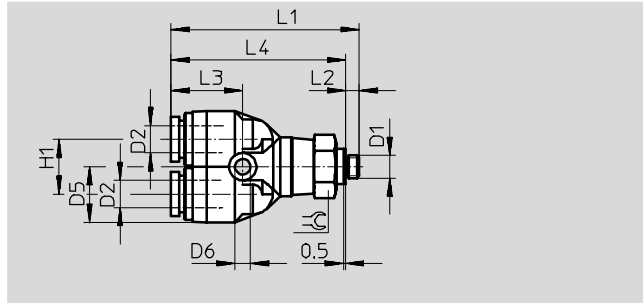

R 螺纹

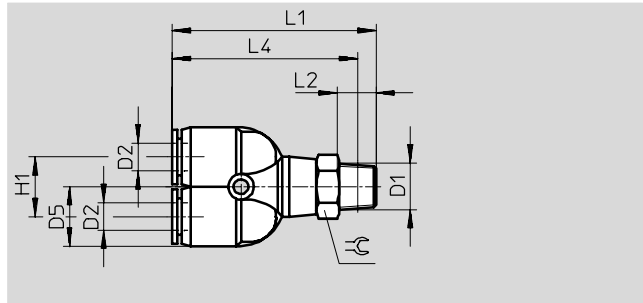

尺寸和订货数据															
接口	公称通径	气管外径	D5	D6	H1	L1	L2	L3	L4	≈C	每件重量	订货号	型号		PU*
D1	[mm]	D2	∅	∅							[g]				
公制螺纹, 带密封圈															
M5	1.4	4	10	3.4	11	37.6	3	14.1	34.6	10	11	132158	QSY-B-M5-4-20	新产品	20
	1.4	6	12.5	3.4	12	41.4	3	15.8	38.4	12	16	132159	QSY-B-M5-6-20	新产品	20
R 螺纹															
R <sup>1</sup> / <sub>8</sub>	2.1	4	10	-	10.3	36.1	8	-	32.1	10	10	132014	QSY-B- <sup>1</sup> / <sub>8</sub> -4-20		20
	3.5	6	12.5	-	12.5	42.1	8	-	38.1	12	14	132015	QSY-B- <sup>1</sup> / <sub>8</sub> -6-20		20
	4.4	8	14.5	-	14.5	46.0	8	-	42.0	12	17	132016	QSY-B- <sup>1</sup> / <sub>8</sub> -8-20		20
R <sup>1</sup> / <sub>4</sub>	2.1	4	10	-	10.3	41.6	11	-	35.6	14	16	132017	QSY-B- <sup>1</sup> / <sub>4</sub> -4-20		20
	3.6	6	12.5	-	12.5	44.1	11	-	38.0	14	18	132018	QSY-B- <sup>1</sup> / <sub>4</sub> -6-20		20
	4.9	8	14.5	-	14.5	48.0	11	-	42.0	14	21	132019	QSY-B- <sup>1</sup> / <sub>4</sub> -8-20		20
	5.7	10	17.5	-	17.5	51.2	11	-	45.2	14	28	132160	QSY-B- <sup>1</sup> / <sub>4</sub> -10-20	新产品	20
R <sup>3</sup> / <sub>8</sub>	3.6	6	12.5	-	12.5	44.6	12	-	38.2	17	25	132020	QSY-B- <sup>3</sup> / <sub>8</sub> -6-10		10
	4.9	8	14.5	-	14.5	48.5	12	-	42.2	17	28	132021	QSY-B- <sup>3</sup> / <sub>8</sub> -8-10		10
	5.7	10	17.5	-	17.5	51.7	12	-	45.4	17	34	132022	QSY-B- <sup>3</sup> / <sub>8</sub> -10-10		10
	6.4	12	21	-	21	56.9	12	-	50.6	17	42	132161	QSY-B- <sup>3</sup> / <sub>8</sub> -12-10	新产品	10
R <sup>1</sup> / <sub>2</sub>	5.7	10	17.5	-	17.5	54.7	15	-	46.5	21	50	132024	QSY-B- <sup>1</sup> / <sub>2</sub> -10-10		10
	6.5	12	21	-	21	59.9	15	-	51.7	21	58	132025	QSY-B- <sup>1</sup> / <sub>2</sub> -12-10		10

\* 包装单位数量

# 快插/螺纹接头 QS-B

技术参数

## Y形快插接头 QSY-B

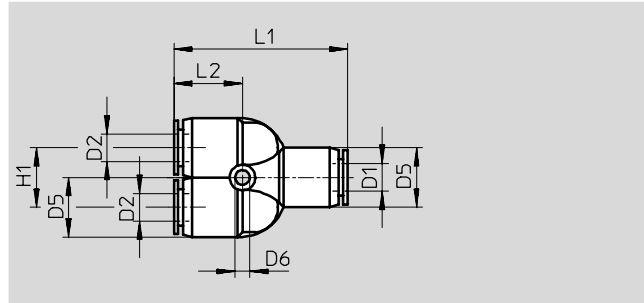

## 2 变径排气口

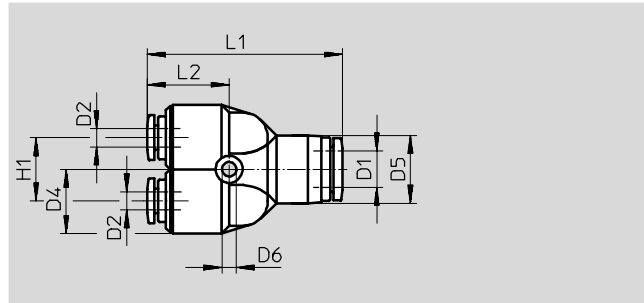

变径

### 尺寸和订货数据

气管外径 D1	公称通径 [mm]	气管外径 D2	D4 ∅	D5 ∅	D6 ∅	H1	L1	L2	每件重量 [g]	订货号	型号	PU*
4	2.3	4	-	10	3.4	11	32.8	14.1	7.6	130955	QSY-B-4-20	20
6	3.6	6	-	13	3.4	12	37.7	15.8	11	130956	QSY-B-6-20	20
8	4.6	8	-	15	3.4	14	42.4	17.2	16	130957	QSY-B-8-20	20
10	5.9	10	-	18	4.5	18	48.4	19.5	26	130958	QSY-B-10-10	10
12	7	12	-	21.5	4.2	20	54.8	22.2	37	130959	QSY-B-12-10	10
16	8.5	16	-	25	4.5	24	62.2	22.1	45	132139	QSY-B-16-10	· 新产品 10
变径												
6	2.3	4	12.5	13	3.4	12	37.2	15.2	11	130960	QSY-B-6-4-20	20
8	2.1	4	14.5	15	3.4	14	43.4	18.2	17	132140	QSY-B-8-4-20	· 新产品 20
	3.6	6	14.5	15	3.4	14	42.5	17.3	15	130961	QSY-B-8-6-20	20
10	3.6	6	18	18	4.5	18	50.2	21.3	27	132141	QSY-B-10-6-10	· 新产品 10
	4.7	8	18	18	4.5	18	48.1	19.2	23	130962	QSY-B-10-8-10	10
12	5.4	8	21	21.5	4.2	20	56.4	23.8	40	132142	QSY-B-12-8-10	· 新产品 10
	5.9	10	21	21.5	4.2	20	54.6	22	36	130963	QSY-B-12-10-10	10
16	7.8	12	25	25	4.5	24	66.5	26.4	77	132143	QSY-B-16-12-10	· 新产品 10

\* 包装单位数量

# 快插/螺纹接头 QS-F, 金属型

技术参数

FESTO

快插/螺纹接头 QS-F  
外螺纹  
带外六角

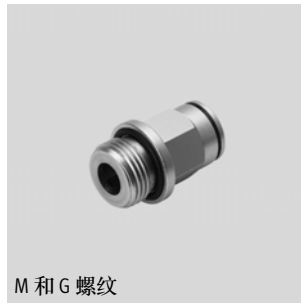

M 和 G 螺纹

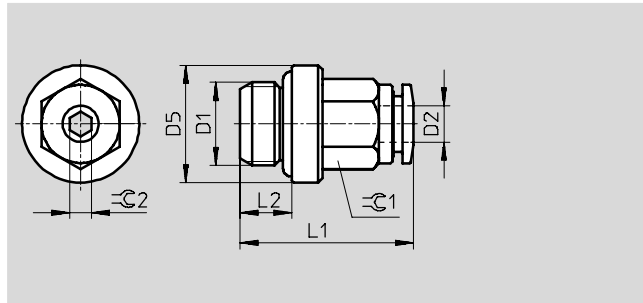

尺寸和订货数据											
接口	公称通径	气管外径	D5 ∅	L1	L2	rC1	rC2	每件重量	订货号	型号	PU*
D1	[mm]	D2						[g]			
<b>公制螺纹</b>											
M5	2.6	4	8	20.5	4	9	2.5	6.1	533844	QS-F-M5-4	10
	2.6	6	8	23	4	11	2.5	9.3	533845	QS-F-M5-6	10
M7	2.6	4	10.2	22	5.5	9	2.5	6.9	533846	QS-F-M7-4	10
	3.6	6	11	25.3	5.5	11	3.5	10.3	533847	QS-F-M7-6	10
<b>G 螺纹, 带密封圈</b>											
G1/8	2.6	4	13.5	19.5	5.5	9	2.5	8.9	193408	QS-F-G1/8-4	10
	4.2	6	13.5	24.8	5.5	11	4	12	193409	QS-F-G1/8-6	10
	5.2	8	12.8	26.5	5.5	13	5	14	193410	QS-F-G1/8-8	10
G1/4	4.2	6	17	22.8	6.5	11	4	16	193411	QS-F-G1/4-6	10
	6.2	8	17	24	6.5	13	6	16	193412	QS-F-G1/4-8	10
	7.3	10	16	28.9	6.5	16	7	23.7	193413	QS-F-G1/4-10	10
	7.3	12	16	31.9	6.5	19	7	32	533848	QS-F-G1/4-12	10
G3/8	6.2	8	20	24	7.5	13	6	23.3	193414	QS-F-G3/8-8	10
	8.3	10	21	29.4	7.5	16	8	30	193415	QS-F-G3/8-10	10
	10.3	12	22	31.9	7.5	19	10	38.1	197487	QS-F-G3/8-12	10
G1/2	8.3	10	24	28.9	9	16	8	42	193416	QS-F-G1/2-10	1
	10.3	12	24	31.4	9	19	10	46	193417	QS-F-G1/2-12	1

\* 包装单位数量



# 快插/螺纹接头 QS-F, 金属型

技术参数

快插/螺纹接头 QS-F...-I  
外螺纹  
带内六角



M 和 G 螺纹

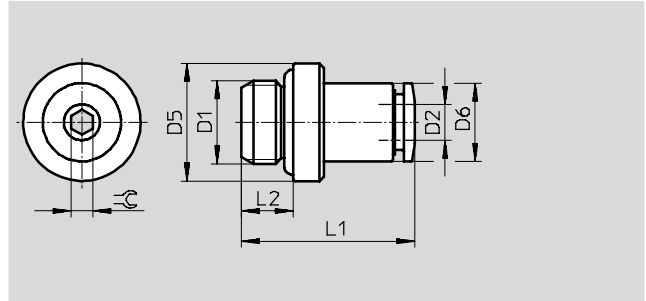

尺寸和订货数据											
接口	公称通径	气管外径	D5	D6	L1	L2	≈C	每件重量	订货号	型号	PU*
D1	[mm]	D2	∅	∅				[g]			
<b>公制螺纹, 带密封圈</b>											
M5	2.6	4	8	9	20.5	4	2.5	6	533924	QS-F-M5-4-I	10
	2.6	6	8	11	23.5	4	2.5	9	537014	QS-F-M5-6-I	10
M7	2.6	4	11	9	22	5.5	2.5	6.4	533925	QS-F-M7-4-I	10
	4.1	6	11	11	25.3	5.5	3.5	9.4	533926	QS-F-M7-6-I	10
<b>G 螺纹</b>											
G1/8	2.6	4	13	9	19.5	5.5	2.5	8.6	533927	QS-F-G1/8-4-I	10
	4.2	6	13	11	24.8	5.5	4	13.4	533928	QS-F-G1/8-6-I	10
	5.2	8	13	13	26.5	5.5	5	13.1	533929	QS-F-G1/8-8-I	10
G1/4	6.2	8	16	13	24	6.5	6	14.6	533930	QS-F-G1/4-8-I	10
	7.3	10	16	16	28.9	6.5	7	21	533931	QS-F-G1/4-10-I	10
G3/8	10.3	12	22	19	31.9	7.5	10	34.3	533932	QS-F-G3/8-12-I	10

\* 包装单位数量

快插/螺纹接头 QSF-F  
内螺纹  
带外六角

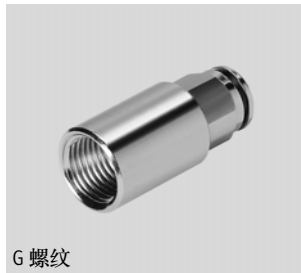

G 螺纹

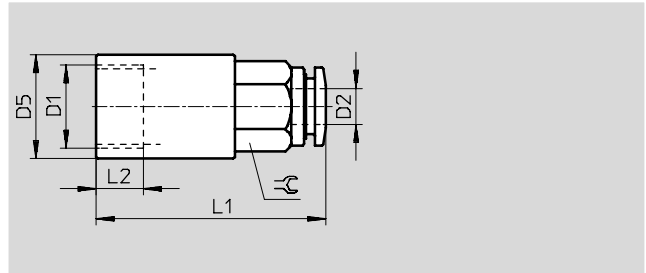

尺寸和订货数据											
接口	公称通径	气管外径	D5	L1	L2	≈C	每件重量	订货号	型号	PU*	
D1	[mm]	D2	∅				[g]				
<b>G 螺纹</b>											
G1/8	3	4	12	26.5	6.8	9	12.3	533854	QSF-F-G1/8-4	10	
	5	6	12	28.3	6.8	11	12.2	533856	QSF-F-G1/8-6	10	
	7	8	12	28.5	6.8	13	13.9	533858	QSF-F-G1/8-8	10	
G1/4	3	4	17	29.5	9	9	24.9	533855	QSF-F-G1/4-4	10	
	5	6	17	31.3	9	11	21.4	533857	QSF-F-G1/4-6	10	
	7	8	17	32.5	9	13	23.2	533859	QSF-F-G1/4-8	10	

\* 包装单位数量

# 快插/螺纹接头 QS-F, 金属型

技术参数

FESTO

穿板式快插接头 QSSF-F  
带内螺纹

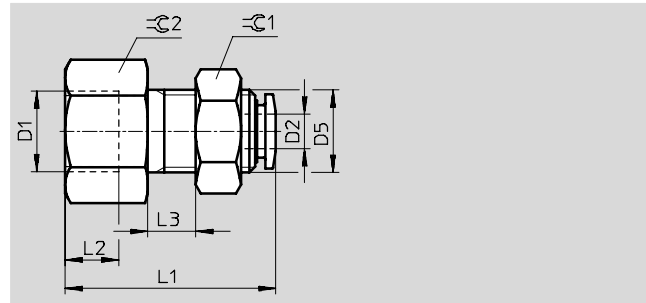

尺寸和订货数据												
接口	公称通径	气管外径	D5 ∅	L1	L2	L3 max.	≈C1	≈C2	每件重量 [g]	订货号	型号	PU*
D1	[mm]	D2										
<b>G 螺纹</b>												
G <sup>1</sup> / <sub>8</sub>	3	4	M10x1	25.5	6.8	6.6	13	15	19.7	533919	QSSF-F-G <sup>1</sup> / <sub>8</sub> -4	10
	5	6	M14x1	26.8	6.8	6.6	17	15	27.8	533920	QSSF-F-G <sup>1</sup> / <sub>8</sub> -6	10
	7	8	M16x1	29	6.8	6.6	19	17	38.4	533922	QSSF-F-G <sup>1</sup> / <sub>8</sub> -8	10
G <sup>1</sup> / <sub>4</sub>	5	6	M14x1	31.3	9	6.6	17	17	38.3	533921	QSSF-F-G <sup>1</sup> / <sub>4</sub> -6	10
	7	8	M16x1	33.5	9	6.6	19	17	39.6	533923	QSSF-F-G <sup>1</sup> / <sub>4</sub> -8	10

\* 包装单位数量

# 快插/螺纹接头 QS-F, 金属型

技术参数

FESTO

快插/螺纹接头 QS-F...H  
带插入式轴套

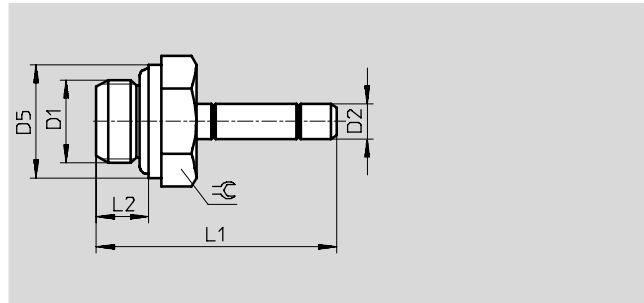

尺寸和订货数据										
接口	公称通径	插入式轴套 套 Ø	D5 Ø	L1	L2	≈C	每件重量 [g]	订货号	型号	PU*
D1	[mm]	D2								
<b>M 螺纹</b>										
M5	2	4	8	24.7	4	8	3.1	533874	QS-F-M5-4H	10
	2.6	6	8	27.5	4	8	5.8	533875	QS-F-M5-6H	10
M7	2	4	11	26.2	5.5	9	4.1	533876	QS-F-M7-4H	10
	3.5	6	11	29	5.5	9	5.9	533877	QS-F-M7-6H	10
<b>G 螺纹</b>										
G1/8	2	4	13	27.7	5.5	9	8.3	533878	QS-F-G1/8-4H	10
	4	6	13	30.5	5.5	13	10.1	533879	QS-F-G1/8-6H	10
	6	8	13	32	5.5	13	10.3	533880	QS-F-G1/8-8H	10
G1/4	4	6	16	32	6.5	13	12.2	533881	QS-F-G1/4-6H	10
	6	8	16	33.5	6.5	13	13.4	533882	QS-F-G1/4-8H	10
	8	10	16	36.5	6.5	13	20.7	533883	QS-F-G1/4-10H	10
	8	12	16	37.5	6.5	13	20.7	533884	QS-F-G1/4-12H	10
G3/8	6	8	20	35.5	7.5	13	20.6	533885	QS-F-G3/8-8H	10
	8	10	20	39.5	7.5	13	23.5	533886	QS-F-G3/8-10H	10
	10	12	20	40.5	7.5	13	23.6	533887	QS-F-G3/8-12H	10
G1/2	8	10	24	41	9	16	30.9	533888	QS-F-G1/2-10H	10
	10	12	24	42	9	16	31.6	533889	QS-F-G1/2-12H	1

\* 包装单位数量

## 快插/螺纹接头 QS-F, 金属型

技术参数

FESTO

快插接头QS-F

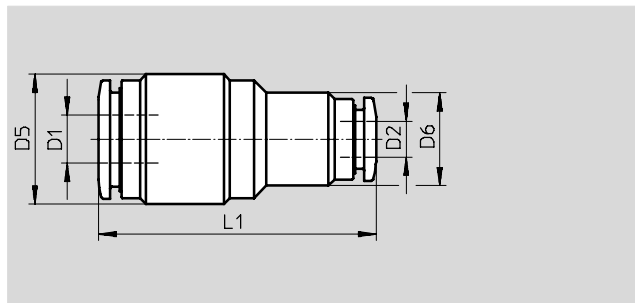
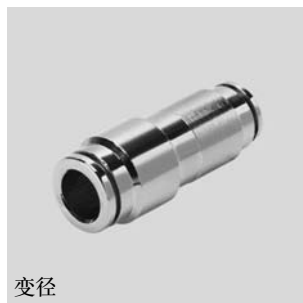
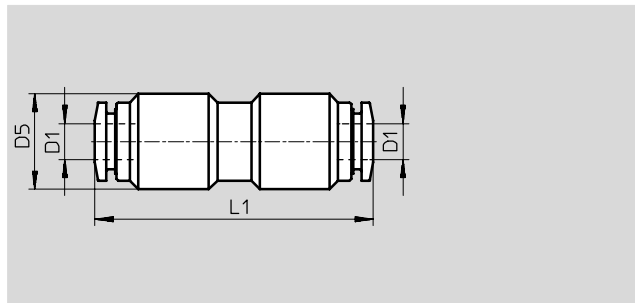

变径

### 尺寸和订货数据

气管外径 D1	公称通径 [mm]	气管外径 D2	D5 ∅	D6 ∅	L1	每件重量 [g]	订货号	型号	PU*
4	3	-	11	-	32	14.3	533939	QS-F-4	10
6	5	-	14	-	36.1	22.5	533940	QS-F-6	10
8	7	-	16	-	38	29.4	533941	QS-F-8	10
10	9	-	18	-	42.3	41.7	533942	QS-F-10	10
12	11	-	22	-	45.8	67.9	533943	QS-F-12	10
变径									
6	3	4	13	11	34.8	16.8	564889	QS-F-6-4	新产品 1
8	5	6	15	13	37.8	23.5	564890	QS-F-8-6	新产品 1
12	7	8	21	15	43.6	48.5	564891	QS-F-12-8	新产品 1

\* 包装单位数量

# 快插/螺纹接头 QS-F, 金属型

技术参数

FESTO

快插接头QS-F...H  
带插入式轴套

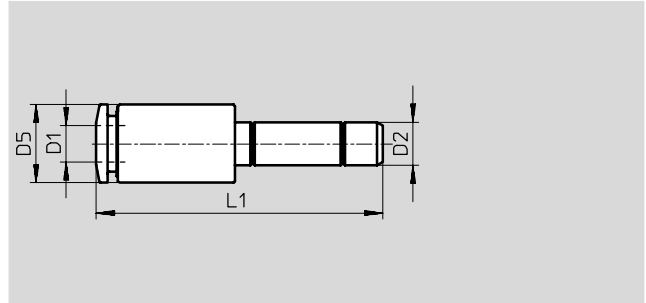

尺寸和订货数据								
气管外径	公称通径	插入式轴套 $\varnothing$	D5	L1	每件重量	订货号	型号	PU*
D1	[mm]	D2	$\varnothing$		[g]			
4	3	6	9	32.5	7.3	533895	QS-F-6H-4	10
4	3	8	9	34	11.2	533896	QS-F-8H-4	10
6	5	8	11	36.3	10.8	533897	QS-F-8H-6	10
4	3	10	13	39	23.5	533898	QS-F-10H-4	10
6	5	10	11	39.3	17.5	533899	QS-F-10H-6	10
8	7	10	13	39	14.2	533900	QS-F-10H-8	10
6	5	12	13	40.3	27.8	533901	QS-F-12H-6	10
8	7	12	13	39.5	21.4	533902	QS-F-12H-8	10
10	9	12	16	41.4	20.8	533903	QS-F-12H-10	10

\* 包装单位数量

# 快插/螺纹接头 QS-F, 金属型

技术参数

插入式轴套 QSH-F

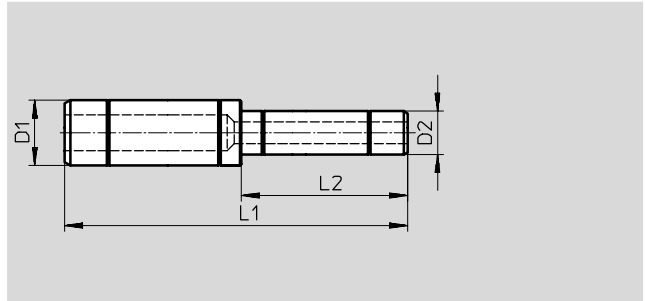
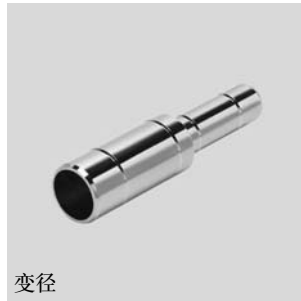
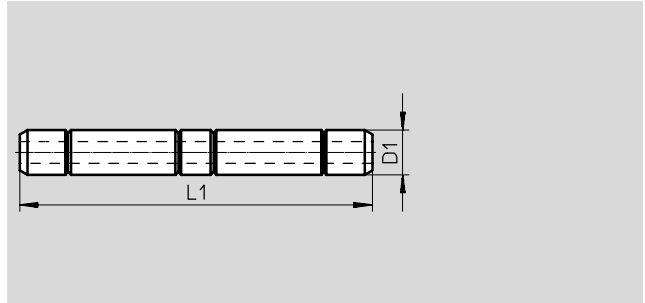

变径

尺寸和订货数据									
插入式轴套∅ D1	公称通径 [mm]	插入式轴套∅ D2	L1	L2	每件重量 [g]	订货号	型号		PU*
4	2	-	33.4	-	2.8	533890	QSH-F-4		10
6	4	-	39	-	4.8	533891	QSH-F-6		10
8	6	-	42	-	8.6	533892	QSH-F-8		10
10	8	-	48	-	10.9	533893	QSH-F-10		10
12	10	-	50	-	14.1	533894	QSH-F-12		10
变径									
6	2	4	41.0	19.5	4.4	564892	QSH-F-6-4	新产品	1
8	4	6	44.5	21.5	7.2	564893	QSH-F-8-6	新产品	1
12	6	8	50.0	23.0	12.6	564894	QSH-F-12-8	新产品	1

\* 包装单位数量

# 快插/螺纹接头 QS-F, 金属型

技术参数



## 堵头 QSC-F...H

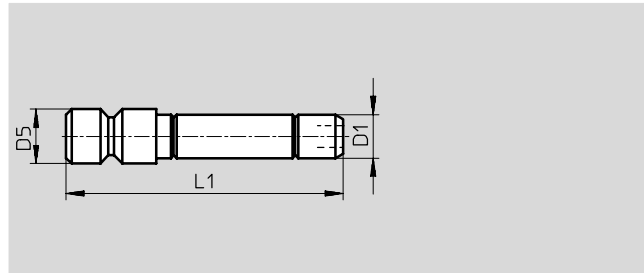

尺寸和订货数据						
插入式 轴套∅ D1	D5 ∅	L1	每件重量 [g]	订货号	型号	PU*
4	5	26	3.1	533904	QSC-F-4H	10
6	7	29	4.6	533905	QSC-F-6H	10
8	9	31.5	7.6	533906	QSC-F-8H	10
10	11	35	10.8	533907	QSC-F-10H	10
12	13	37	14.7	533908	QSC-F-12H	10

\* 包装单位数量

## 锁定螺丝 QSC-F...I

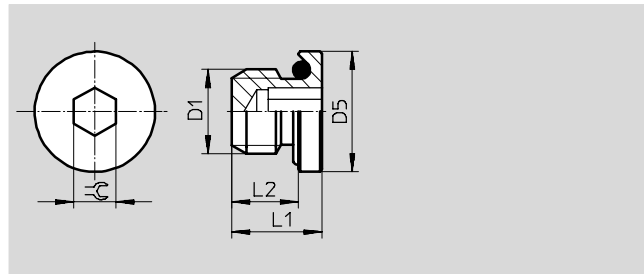

尺寸和订货数据								
接口 D1	D5 ∅	L1	L2	≈	每件重量 [g]	订货号	型号	PU*
<b>M 螺纹, 带密封圈</b>								
M5	8.0	6.5	4.0	2.5	1.0	556855	QSC-F-M5-I	☉ 新产品 10
M7	10.2	8.5	5.5	3.5	2.0	556856	QSC-F-M7-I	☉ 新产品 10
<b>G 螺纹, 带密封圈</b>								
G1/8	14.0	8.5	5.5	4.0	4.9	556857	QSC-F-G1/8-I	☉ 新产品 10
G1/4	17.0	9	6.5	6.0	8.8	556858	QSC-F-G1/4-I	☉ 新产品 10
G3/8	20.0	10.5	7.5	8.0	15.0	556859	QSC-F-G3/8-I	☉ 新产品 10
G1/2	24.0	12.0	9.0	10.0	25.7	556860	QSC-F-G1/2-I	☉ 新产品 10

\* 包装单位数量

# 快插/螺纹接头 QS-F, 金属型

技术参数

FESTO

L形快插/螺纹接头QSL-F

360°可旋转

外螺纹

带外六角

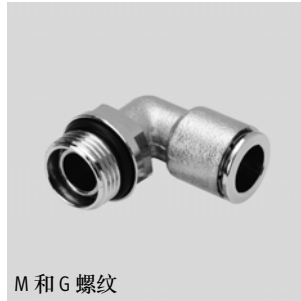

M 和 G 螺纹

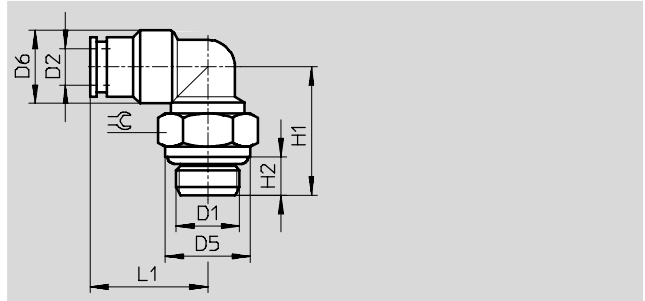

尺寸和订货数据												
接口	公称通径	气管外径	D5 ∅	D6 ∅	H1	H2	L1	☉	每件重量 [g]	订货号	型号	PU*
D1	[mm]	D2										
<b>M 螺纹, 带密封圈</b>												
M5	3	4	8	9	19.7	4	18.2	8	10.7	533849	QSL-F-M5-4	10
	5	6	8	11	19.7	4	20.6	8	14.7	533850	QSL-F-M5-6	10
M7	3	4	10.2	9	21.7	5.5	18.2	9	11.3	533851	QSL-F-M7-4	10
	5	6	10.2	11	21.7	5.5	20.6	9	15.6	533852	QSL-F-M7-6	10
<b>G 螺纹, 带密封圈</b>												
G <sup>1</sup> / <sub>8</sub>	3	4	12.8	11	18.2	5.5	17.7	13	17.6	193418	QSL-F-G <sup>1</sup> / <sub>8</sub> -4	10
	5	6	12.8	11	18.2	5.5	19.8	13	16	193419	QSL-F-G <sup>1</sup> / <sub>8</sub> -6	10
	7	8	12.8	13	20.2	5.5	23	13	20	193420	QSL-F-G <sup>1</sup> / <sub>8</sub> -8	10
G <sup>1</sup> / <sub>4</sub>	5	6	15.8	11	21	6.5	22.1	16	24.5	193421	QSL-F-G <sup>1</sup> / <sub>4</sub> -6	10
	7	8	15.8	13	21	6.5	23	16	24	193422	QSL-F-G <sup>1</sup> / <sub>4</sub> -8	10
	9	10	15.8	16	23	6.5	26.4	16	34.6	193423	QSL-F-G <sup>1</sup> / <sub>4</sub> -10	10
	10	12	15.8	19	23	6.5	28.9	16	49	533853	QSL-F-G <sup>1</sup> / <sub>4</sub> -12	10
G <sup>3</sup> / <sub>8</sub>	7	8	20	13	24	7.5	24.5	18	34.2	193424	QSL-F-G <sup>3</sup> / <sub>8</sub> -8	10
	9	10	20	16	24	7.5	26.4	18	36.6	193425	QSL-F-G <sup>3</sup> / <sub>8</sub> -10	10
	10	12	20	19	24	7.5	28.9	18	51.1	197486	QSL-F-G <sup>3</sup> / <sub>8</sub> -12	10
G <sup>1</sup> / <sub>2</sub>	9	10	25	17	29	9	27.9	21	66	193426	QSL-F-G <sup>1</sup> / <sub>2</sub> -10	1
	10	12	25	19	29	9	28.9	21	70	193427	QSL-F-G <sup>1</sup> / <sub>2</sub> -12	1

\* 包装单位数量



# 快插/螺纹接头 QS-F, 金属型

技术参数



L形快插/螺纹接头(加长) QSLL-F  
外螺纹  
带外六角

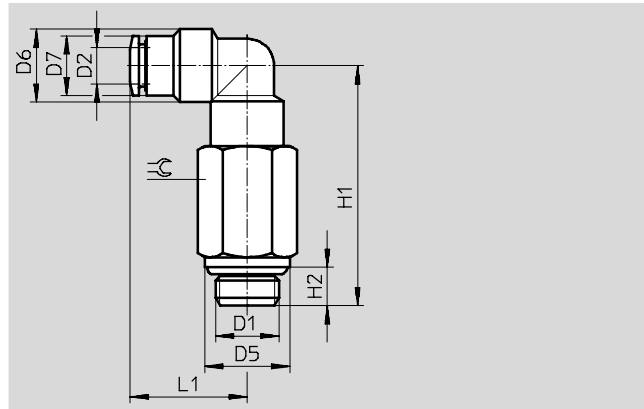

尺寸和订货数据													
接口	公称通径	气管外径	D5	D6	D7	H1	H2	L1	≈C	每件重量	订货号	型号	PU*
D1	[mm]	D2	∅	∅						[g]			
G1/8	3	4	12.8	11	9	35.7	5.5	17.2	13	33.2	556843	QSLL-F-G1/8-4	新产品 10
	3.8	6	12.8	11	-	35.7	5.5	20.8	13	34.3	556844	QSLL-F-G1/8-6	新产品 10
	3.8	8	12.8	13	-	38.0	5.5	23.0	13	39	556845	QSLL-F-G1/8-8	新产品 10
G1/4	5	6	15.8	11	-	42.7	6.5	22.2	16	51.4	556846	QSLL-F-G1/4-6	新产品 10
	6	8	15.8	13	-	43.9	6.5	23.0	16	51.7	556847	QSLL-F-G1/4-8	新产品 10
	6	10	15.8	16	-	46.7	6.5	26.4	16	58.7	556848	QSLL-F-G1/4-10	新产品 10
	6	12	15.8	19	-	47.7	6.5	28.9	16	75.9	556849	QSLL-F-G1/4-12	新产品 10
G3/8	7	8	20.0	13	-	47.8	7.5	24.5	18	66.1	556850	QSLL-F-G3/8-8	新产品 10
	8.8	10	20.0	16	-	47.8	7.5	25.9	18	70.5	556851	QSLL-F-G3/8-10	新产品 10
	8.8	12	20.0	19	-	49.3	7.5	28.9	18	82.7	556852	QSLL-F-G3/8-12	新产品 10
G1/2	9	10	25.0	17	16	51.9	9.0	27.9	21	102.3	556853	QSLL-F-G1/2-10	新产品 1
	10	12	25.0	19	-	51.9	9.0	28.9	21	106.2	556854	QSLL-F-G1/2-12	新产品 1

\* 包装单位数量

L形快插接头 QSL-F

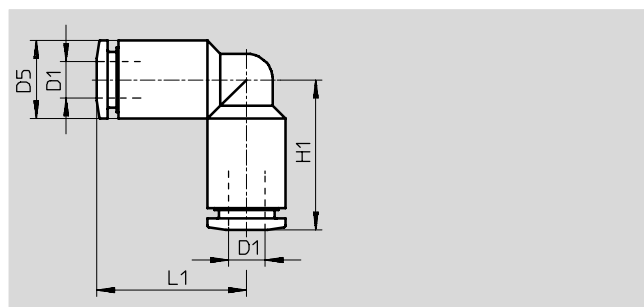

尺寸和订货数据							
气管外径	公称通径	D5	L1	每件重量	订货号	型号	PU*
D1	[mm]	∅		[g]			
4	3	9	17.3	9	533860	QSL-F-4	10
6	5	11	20.6	15.1	533861	QSL-F-6	10
8	7	13	23	19.1	533862	QSL-F-8	10
10	9	16	26.4	29.6	533863	QSL-F-10	10
12	10	19	28.9	50.7	533864	QSL-F-12	10

\* 包装单位数量

# 快插/螺纹接头 QS-F, 金属型

技术参数

FESTO

穿板式快插接头 QSS-F

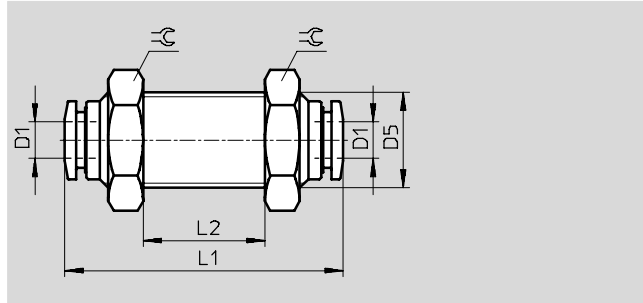

## 尺寸和订货数据

气管外径 D1	公称通径 [mm]	D5 Ø	L1	L2	≡C	每件重量 [g]	订货号	型号	PU*
4	3	M11x1	32	8	14	18.3	533909	QSS-F-4	10
6	5	M14x1	36.1	8	17	29.9	533910	QSS-F-6	10
8	7	M16x1	38	10	18	34.6	533911	QSS-F-8	10
10	9	M18x1	42.3	12	21	50.5	533912	QSS-F-10	10
12	10	M22x1	45.8	17	26	88.2	533913	QSS-F-12	10

\* 包装单位数量

# 快插/螺纹接头 QS-F, 金属型

技术参数



## T形快插/螺纹接头QST-F

360°可旋转

外螺纹

带外六角



M 和 G 螺纹

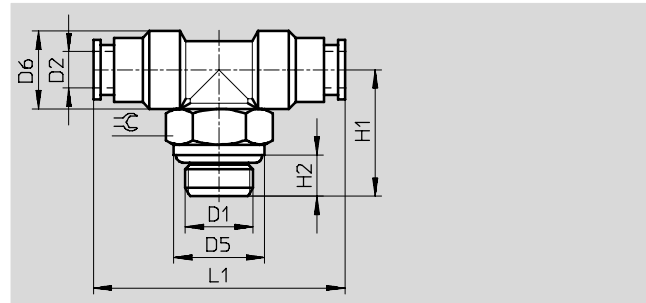

尺寸和订货数据												
接口	公称通径	气管外径	D5 ∅	D6 ∅	H1	H2	L1	≈C	每件重量s [g]	订货号	型号	PU*
D1	[mm]	D2										
<b>M 螺纹</b>												
M5	3	4	8	9	19.7	4	34.6	8	14.6	533914	QST-F-M5-4	10
	5	6	8	11	19.7	4	41.2	8	20.9	533915	QST-F-M5-6	10
M7	3	4	10.2	9	21.7	5.5	34.6	9	15.9	533916	QST-F-M7-4	10
	5	6	10.2	11	21.7	5.5	41.2	9	22.2	533917	QST-F-M7-6	10
<b>G 螺纹, 带密封圈</b>												
G1/8	3	4	12.8	11	18.2	5.5	34.6	13	22	193428	QST-F-G1/8-4	10
	5	6	12.8	11	18.2	5.5	39.6	13	22	193429	QST-F-G1/8-6	10
	7	8	12.8	13	20.2	5.5	46	13	28	193430	QST-F-G1/8-8	10
G1/4	5	6	15.8	11	21	6.5	44.2	16	32	193431	QST-F-G1/4-6	10
	7	8	15.8	13	21	6.5	46	16	33.6	193432	QST-F-G1/4-8	10
	9	10	15.8	16	23	6.5	52.8	16	47.5	193433	QST-F-G1/4-10	10
	10	12	15.8	19	23	6.5	57.8	16	64.2	533918	QST-F-G1/4-12	10
G3/8	7	8	20	13	24	7.5	49	18	44	193434	QST-F-G3/8-8	10
	9	10	20	16	24	7.5	52.8	18	51	193435	QST-F-G3/8-10	10
	10	12	20	19	24	7.5	57.8	18	68	197485	QST-F-G3/8-12	10
G1/2	9	10	25	17	29	9	55.8	21	84	193436	QST-F-G1/2-10	1
	10	12	25	19	29	9	57.8	21	90	193437	QST-F-G1/2-12	1

\* 包装单位数量

# 快插/螺纹接头 QS-F, 金属型

技术参数

FESTO

## T形快插接头QST-F

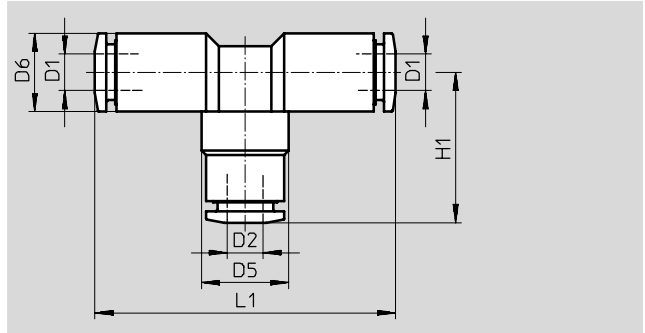

尺寸和订货数据										
气管外径	公称通径	气管外径	D5	D6	H1	L1	每件重量s	订货号	型号	PU*
D1	[mm]	D2	∅	∅			[g]			
4	3	4	9	9	17.3	34.6	13.1	533865	QST-F-4	10
6	5	6	11	11	20.6	41.2	21.3	533866	QST-F-6	10
8	7	8	13	13	23	46	26.9	533867	QST-F-8	10
10	9	10	16	16	26.4	52.8	43.2	533868	QST-F-10	10
12	10	12	19	19	28.9	57.8	66.1	533869	QST-F-12	10
变径										
6	5	4	11	11	20.6	41.2	22.3	533870	QST-F-6-4	10
8	7	6	11	13	23	46	26.5	533871	QST-F-8-6	10
10	9	8	13	16	26.4	52.8	41	533872	QST-F-10-8	10
12	10	10	16	19	28.9	57.8	64.3	533873	QST-F-12-10	10

\* 包装单位数量

## Y形快插接头QSY-F

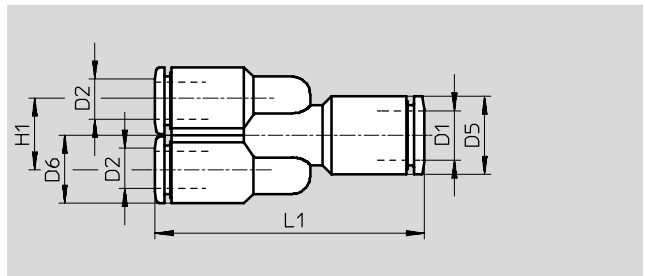

尺寸和订货数据										
气管外径	公称通径	气管外径	D5	D6	H1	L1	每件重量s	订货号	型号	PU*
D1	[mm]	D2	∅	∅			[g]			
6	5	6	11	11	11.5	43.1	26.2	533933	QSY-F-6	10
8	7	8	13	13	13.5	46.5	27.6	533935	QSY-F-8	10
10	9	10	16	16	16.5	49.3	58.8	533937	QSY-F-10	10
变径										
6	3	4	11	9	9.5	38.8	17.8	533934	QSY-F-6-4	10
8	5	6	13	11	11.5	44.8	28.1	533936	QSY-F-8-6	10
10	7	8	16	13	13.5	46.5	39	533938	QSY-F-10-8	10

\* 包装单位数量

# 快插/螺纹接头 CRQS, 不锈钢型

技术参数

## 快插/螺纹接头 CRQS

外螺纹

带内六角和外六角



M 螺纹

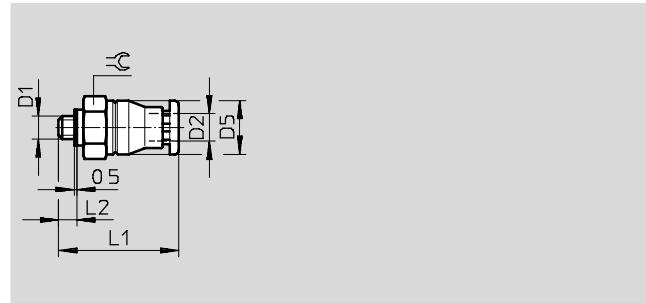

R 螺纹

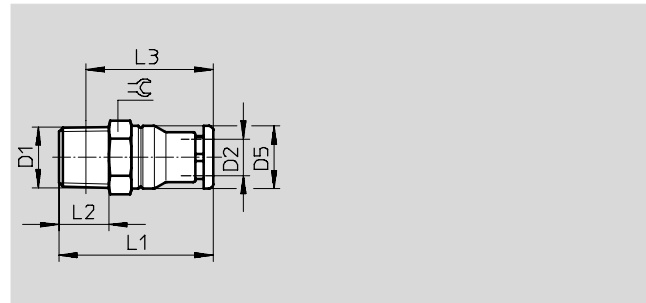

尺寸和订货数据											
接口	公称通径	气管外径	D5	L1	L2	L3	≈C	每件重量	订货号	型号	PU*
D1	[mm]	D2	∅					[g]			
公制螺纹, 带密封圈											
M5x0.8	2	4	9.8	24.2	3	-	10	6	162860	CRQS-M5-4	1
	2	6	11.8	25.6	3	-	12	8.4	162861	CRQS-M5-6	1
R 螺纹											
R1/8	2.5	4	9.8	27.2	8	23.3	10	8.7	132643	CRQS-1/8-4	👁️ 新产品 1
	4.1	6	11.8	27.6	8	23.7	12	9.9	162862	CRQS-1/8-6	1
	5.1	8	13.8	30.7	8	26.8	14	13	162863	CRQS-1/8-8	1
R1/4	4.2	6	11.8	31.6	11	25.6	14	18	132644	CRQS-1/4-6	👁️ 新产品 1
	5.8	8	13.8	33.7	11	27.7	14	18	162864	CRQS-1/4-8	1
	5.9	10	16.8	36	11	29.9	17	22	162865	CRQS-1/4-10	1
R3/8	6	10	16.8	38	12	31.6	17	29	162866	CRQS-3/8-10	1
	7.6	12	19.8	39.8	12	33.4	21	38	162867	CRQS-3/8-12	1
R1/2	8.1	12	19.8	42.8	15	34.6	22	55	162868	CRQS-1/2-12	1
	10.1	16	23.7	49.9	15	41.6	24	59	162869	CRQS-1/2-16	1

\* 包装单位数量

# 快插/螺纹接头 CRQS, 不锈钢型

技术参数

快插/螺纹接头 CRQS-...-I

外螺纹

带内六角



M 螺纹

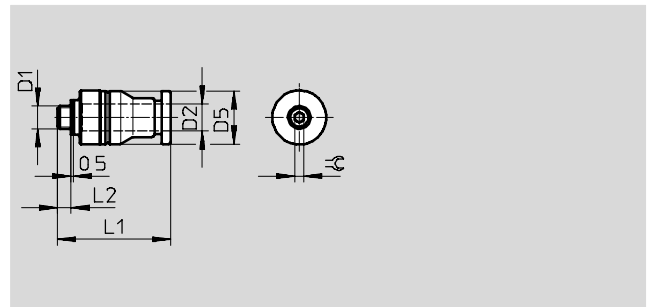

R 螺纹

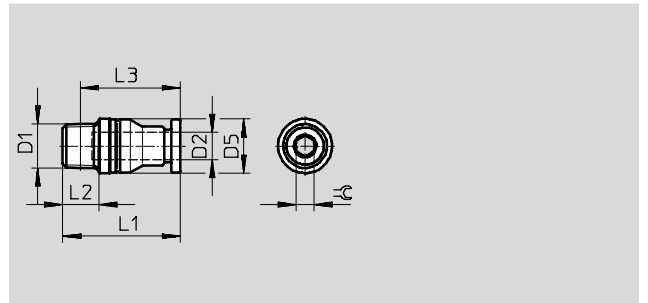

尺寸和订货数据											
接口	公称通径	气管外径	D5	L1	L2	L3	≈C	每件重量	订货号	型号	PU*
D1	[mm]	D2	∅					[g]			
公制螺纹, 带密封圈											
M5	2	4	10	22.7	3	-	2	5	132328	CRQS-M5-4-I	1
	2	6	12	25.1	3	-	2	7.7	132329	CRQS-M5-6-I	1
R 螺纹											
R1/8	4.1	6	12	26.1	8	22.2	4	8.4	132330	CRQS-1/8-6-I	1
	5.1	8	14	30.2	8	26.3	5	12	132331	CRQS-1/8-8-I	1
R1/4	5.8	8	14	31.2	11	25.2	6	15	132332	CRQS-1/4-8-I	1
	5.9	10	17	36.0	11	29.9	6	21	132333	CRQS-1/4-10-I	1
R3/8	6	10	17	34.0	12	27.6	6	24	132334	CRQS-3/8-10-I	1
	7.6	12	20	36.3	12	29.9	8	28	132335	CRQS-3/8-12-I	1
R1/2	8.1	12	22	39.3	15	31.1	8	45	132336	CRQS-1/2-12-I	1
	10.1	16	24	46.7	15	38.6	12	47	132337	CRQS-1/2-16-I	1

\* 包装单位数量

# 快插/螺纹接头 CRQS, 不锈钢型

技术参数

FESTO

## 快插接头CRQS

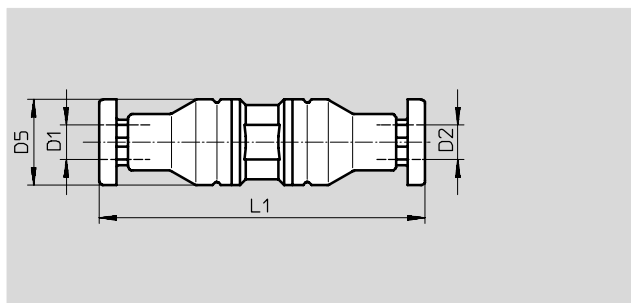

尺寸和订货数据								
气管外径	公称通径	气管外径	D5	L1	每件重量	订货号	型号	PU*
D1	[mm]	D2	-∅		[g]			
4	2.4	4	9.8	37.4	9.2	130645	CRQS-4	1
6	3.7	6	11.8	40.3	14	130646	CRQS-6	1
8	5.8	8	13.8	44.5	18	130647	CRQS-8	1
10	6.6	10	16.8	51.9	29	130648	CRQS-10	1
12	7.9	12	19.8	55.6	45	130649	CRQS-12	1
16	10.5	16	23.7	66.4	64	130650	CRQS-16	1
Reducing								
6	2.3	4	11.8	38.7	11	130651	CRQS-6-4	1
8	3.7	6	13.8	42.2	15	130652	CRQS-8-6	1
10	5.4	8	16.8	48.2	22	130653	CRQS-10-8	1
12	8.1	10	19.8	53.8	34	130654	CRQS-12-10	1
16	7.3	12	23.7	61	50	130655	CRQS-16-12	1

\* 包装单位数量

## 穿板式快插接头 CRQSS

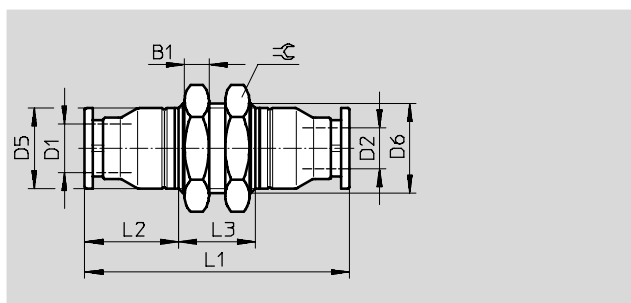

尺寸和订货数据													
气管外径	公称通径	气管外径	B1	D5	D6	L1	L2	L3	≡	每件重量	订货号	型号	PU*
D1	[mm]	D2		∅	∅					[g]			
公制螺纹, 带密封圈													
4	2.4	4	4	9.8	M12x1	45.4	15.2	13	14	19	164210	CRQSS-4	1
6	3.7	6	4	11.8	M14x1	46.3	15.6	15	17	28	164211	CRQSS-6	1
8	5.7	8	4	13.8	M16x1	50.5	17.7	15	19	35	164213	CRQSS-8	1
10	6.7	10	5	16.8	M20x1	56.9	20	17	24	60	164215	CRQSS-10	1
12	7.9	12	6	19.8	M22x1	62.6	21.8	19	27	87	164217	CRQSS-12	1
16	10.4	16	6	23.7	M27x1.5	72.4	26.7	19	32	118	164219	CRQSS-16	1

\* 包装单位数量

# 快插/螺纹接头 CRQS, 不锈钢型

技术参数

FESTO

## L形快插/螺纹接头 CRQSL

360° 可旋转

外螺纹

带外六角



M 螺纹

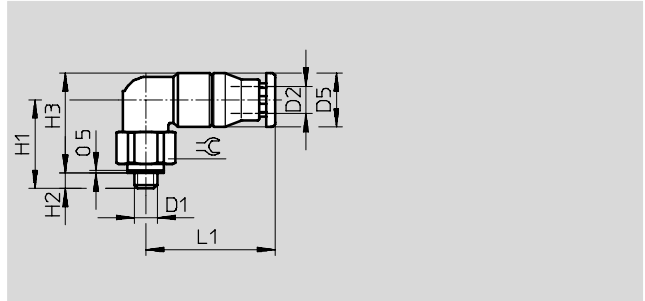

R 螺纹

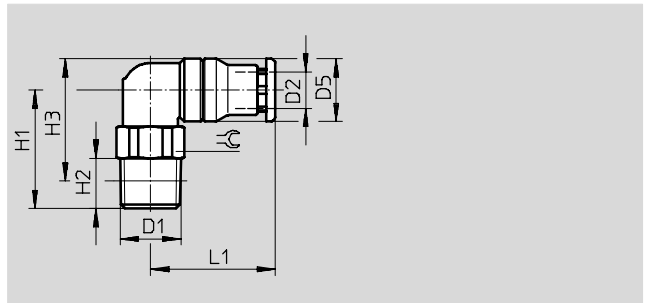

尺寸和订货数据												
接口	公称通径	气管外径	D5	H1	H2	H3	L1	≈	每件重量	订货号	型号	PU*
D1	[mm]	D2	∅						[g]			
公制螺纹, 带密封圈												
M5x0.8	2	4	9.8	17	3	18.9	22.2	10	13	162870	CRQSL-M5-4	1
	2	6	11.8	19	3	21.9	23.6	12	19	162871	CRQSL-M5-6	1
R 螺纹												
R1/8	2.2	4	9.8	19	8	19.9	22.2	10	15	132598	CRQSL-1/8-4	☉ 新产品 1
	3.9	6	11.8	20.5	8	22.4	23.6	12	20	162872	CRQSL-1/8-6	1
	5.2	8	13.8	23	8	25.9	26.2	14	27	162873	CRQSL-1/8-8	1
R1/4	3.6	6	11.8	23	11	22.9	23.6	14	27	132599	CRQSL-1/4-6	☉ 新产品 1
	5.1	8	13.8	25	11	25.9	26.2	14	31	162874	CRQSL-1/4-8	1
	6	10	16.8	28.5	11	30.9	30.5	17	46	162875	CRQSL-1/4-10	1
R3/8	6	10	16.8	28.5	12	30.6	30.5	17	52	162876	CRQSL-3/8-10	1
	8.1	12	19.8	30	12	33.6	33.3	21	69	162877	CRQSL-3/8-12	1
R1/2	7.9	12	19.8	34	15	35.7	33.3	22	89	162878	CRQSL-1/2-12	1
	9.4	16	23.7	36	15	39.7	40.7	24	105	162879	CRQSL-1/2-16	1

\* 包装单位数量



# 快插/螺纹接头 CRQS, 不锈钢型

技术参数

FESTO

## L形快插接头CRQSL

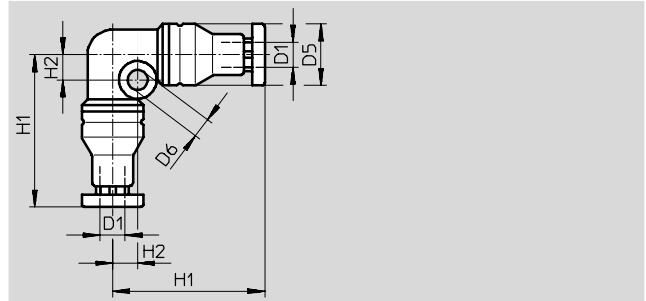

尺寸和订货数据									
气管外径	公称通径	D5	D6	H1	H2	每件重量	订货号	型号	PU*
D1	[mm]	∅	∅			[g]			
4	2.1	9.8	3.2	24.2	4	13	130662	CRQSL-4	1
6	3.5	11.8	3.2	26.6	5	20	130663	CRQSL-6	1
8	5.1	13.8	3.2	29.7	6	27	130664	CRQSL-8	1
10	6.1	16.8	4.2	35	7	43	130665	CRQSL-10	1
12	7.8	19.8	4.2	37.8	8	62	130666	CRQSL-12	1
16	9.4	23.7	4.2	45.2	9,5	91	130667	CRQSL-16	1

\* 包装单位数量

# 快插/螺纹接头 CRQS, 不锈钢型

技术参数

FESTO

## T形快插/螺纹接头 CRQST

360° 可旋转

外螺纹

带外六角

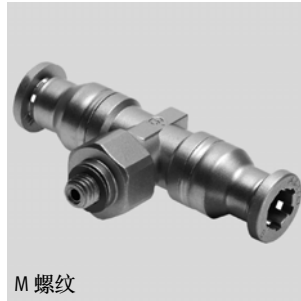

M 螺纹

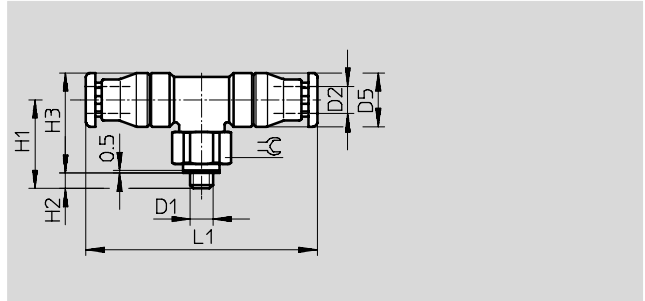

R 螺纹

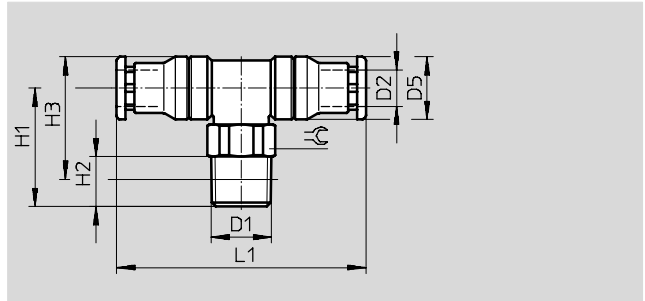

尺寸和订货数据												
接口	公称通径	气管外径	D5 -Ø	H1	H2	H3	L1	≈C	每件重量	订货号	型号	PU*
D1	[mm]	D2							[g]			
公制螺纹, 带密封圈												
M5x0.8	2	4	9.8	18.9	3	17	44.4	10	17	164200	CRQST-M5-4	1
	2	6	11.8	21.9	3	19	47.3	12	25	164201	CRQST-M5-6	1
R 螺纹												
R1/8	3.7	6	11.8	22.4	8	20.5	47.3	12	26	164202	CRQST-1/8-6	1
	5	8	13.8	25.9	8	23	52.5	14	34	164203	CRQST-1/8-8	1
R1/4	5	8	13.8	25.9	11	25	52.5	14	38	164204	CRQST-1/4-8	1
	5.9	10	16.8	30.9	11	28.5	61	17	56	164205	CRQST-1/4-10	1
R3/8	5.9	10	16.8	30.6	12	28.5	61	17	62	164206	CRQST-3/8-10	1
	8.1	12	19.8	33.6	12	30	66.6	21	85	164207	CRQST-3/8-12	1
R1/2	8.1	12	19.8	35.7	15	34	66.6	22	106	164208	CRQST-1/2-12	1
	9.5	16	23.7	39.7	15	36	81.4	24	128	164209	CRQST-1/2-16	1

\* 包装单位数量

# 快插/螺纹接头 CRQS, 不锈钢型

技术参数

FESTO

## T形快插接头CRQST

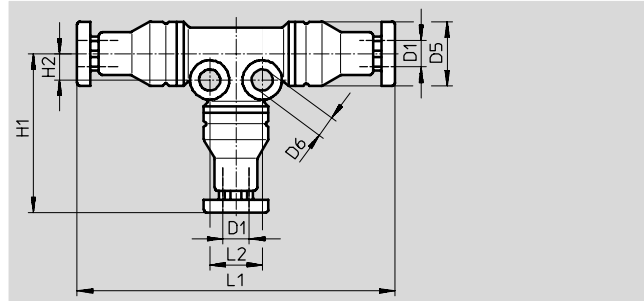

尺寸和订货数据											
气管外径	公称通径	D5	D6	H1	H2	L1	L2	每件重量	订货号	型号	PU*
D1	[mm]	∅	∅					[g]			
4	2.1	9.8	3.2	24.2	4	48.4	8	19	130668	CRQST-4	1
6	3.5	11.8	3.2	26.7	5	53.3	10	28	130669	CRQST-6	1
8	5	13.8	3.2	29.8	6	59.5	12	38	130670	CRQST-8	1
10	6.1	16.8	4.2	35	7	69.9	14	60	130671	CRQST-10	1
12	8	19.8	4.2	37.8	8	75.6	16	87	130672	CRQST-12	1
16	9.7	23.7	4.2	45.2	9.5	90.4	19	126	130673	CRQST-16	1

\* 包装单位数量

## Y形快插接头CRQSY

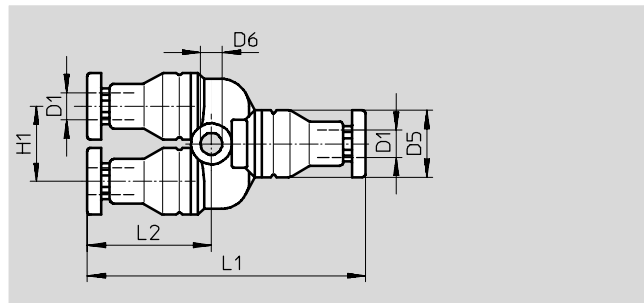

尺寸和订货数据											
气管外径	公称通径	D5	D6	H1	L1	每件重量	订货号	型号	PU*		
D1	[mm]	∅	∅			[g]					
4	2	9.8	3.2	11	40.8	15	130656	CRQSY-4	1		
6	3.3	11.8	3.2	13	44.3	24	130657	CRQSY-6	1		
8	4.9	13.8	3.2	15	51	34	130658	CRQSY-8	1		
10	5.6	16.8	4.3	18	58.5	52	130659	CRQSY-10	1		
12	7	19.8	4.3	21	64.6	79	130660	CRQSY-12	1		
16	8.2	23.7	4.3	25	78.4	121	130661	CRQSY-16	1		

\* 包装单位数量

# 快插/螺纹接头 QS-V0, 阻燃型

技术参数

## 快插/螺纹接头 QS-V0

外螺纹  
带外六角



R 螺纹

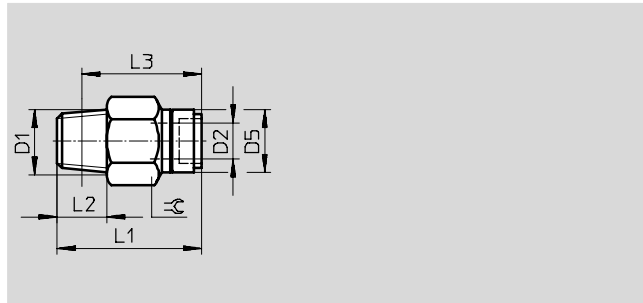

G 螺纹

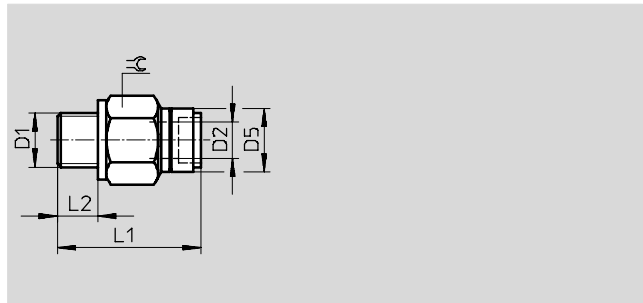

尺寸和订货数据												
接口	公称通径	气管外径	D5	L1	L2	L3	≈C	每件重量	订货号	型号	PU*	
D1	[mm]	D2	∅					[g]				
<b>R 螺纹</b>												
R1/8	2.6	4	12	26.1	8	22.1	10	8.7	132888	QS-V0-1/8-4	新产品	10
	4	6	14	28	8	24	12	10	160500	QS-V0-1/8-6		10
	5	8	16	33.5	8	29.5	14	16.5	160501	QS-V0-1/8-8		10
R1/4	4	6	14	30	11	24	14	18	160502	QS-V0-1/4-6		10
	5	8	16	32	11	26	14	16.5	160503	QS-V0-1/4-8		10
	6.7	10	19	35.5	11	29.5	17	21.5	160504	QS-V0-1/4-10		10
R3/8	6.7	12	22	40.9	11	34.9	21	45	160505	QS-V0-1/4-12		10
	5	8	16	29.5	12	23	17	25	160506	QS-V0-3/8-8		10
	6.7	10	19	35	12	28.5	17	27.5	160507	QS-V0-3/8-10		1
R1/2	8.7	12	22	36.9	12	30.6	21	37	160508	QS-V0-3/8-12		1
	6.7	10	19	36	15	28	21	50.5	160509	QS-V0-1/2-10		1
8.7	12	22	38.9	15	30.7	21	51	160510	QS-V0-1/2-12		1	
<b>G 螺纹, 带密封圈</b>												
G1/8	4	6	14	26.6	5.1	-	13	9.8	186314	QS-V0-G1/8-6		10
	5	8	16	31.9	5.1	-	14	15	186315	QS-V0-G1/8-8		10
G1/4	4	6	14	27.1	5.6	-	17	19	186316	QS-V0-G1/4-6		10
	5	8	16	27.9	5.6	-	17	17	186317	QS-V0-G1/4-8		10
	6.7	10	19	34.9	5.6	-	17	23	186318	QS-V0-G1/4-10		10
	6.7	12	22	39.9	5.6	-	21	52	186319	QS-V0-G1/4-12		10
G3/8	5	8	16	27.6	6.6	-	19	25	186320	QS-V0-G3/8-8		10
	6.7	10	19	31.4	6.6	-	19	26	186321	QS-V0-G3/8-10		10
	8.7	12	22	37.3	6.6	-	21	39	186322	QS-V0-G3/8-12		10
G1/2	6.7	10	19	32	7.6	-	24	53	186323	QS-V0-G1/2-10		1
	8.7	12	22	33.8	7.6	-	24	48	186324	QS-V0-G1/2-12		1

\* 包装单位数量

## 快插/螺纹接头 QS-V0, 阻燃型

技术参数

FESTO

快插接头QS-V0

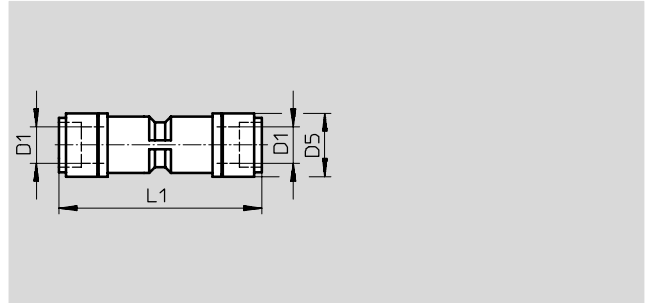

尺寸和订货数据							
气管外径 D1	公称通径 [mm]	D5	L1	每件重量 [g]	订货号	型号	PU*
4	2.6	12	41	6	132890	QS-V0-4	10
6	4	14	45.1	7.9	160546	QS-V0-6	10
8	5	16	48.2	11	160547	QS-V0-8	10
10	6.7	19	53.8	18	160548	QS-V0-10	10
12	8.7	22.2	57.8	26	160549	QS-V0-12	10

\* 包装单位数量

# 快插/螺纹接头 QS-V0, 阻燃型

技术参数

L形快插/螺纹接头 QSL-V0

外螺纹

带外六角



R 螺纹

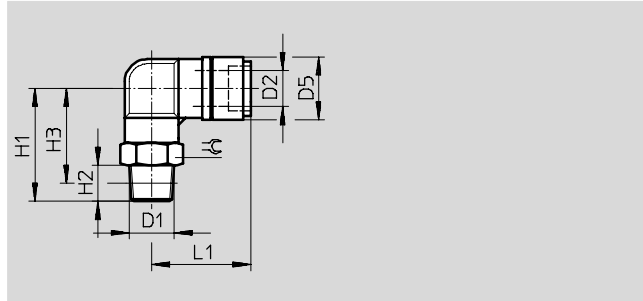

G 螺纹

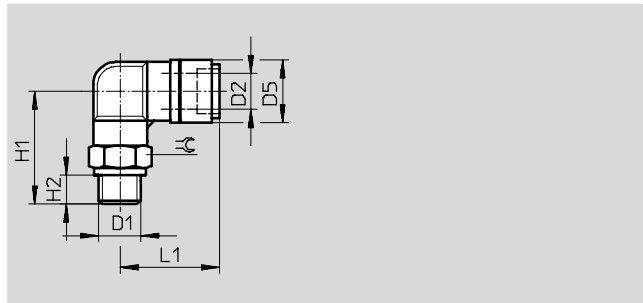

尺寸和订货数据													
接口	公称通径	气管外径	D5	H1	H2	H3	L1	≈	每件重量	订货号	型号	PU*	
D1	[mm]	D2	∅						[g]				
<b>R 螺纹</b>													
R <sup>1</sup> / <sub>8</sub>	2.3	4	12	23.3	8	19.3	23.1	10	12	132891	QSL-V0- <sup>1</sup> / <sub>8</sub> -4	· 新产品	10
	3.6	6	14	25	8	21.1	24.9	12	15	160511	QSL-V0- <sup>1</sup> / <sub>8</sub> -6		10
	4.6	8	16	28	8	24.1	27.9	14	19	160512	QSL-V0- <sup>1</sup> / <sub>8</sub> -8		10
R <sup>1</sup> / <sub>4</sub>	3.6	6	14	28	11	22	24.9	14	23	160513	QSL-V0- <sup>1</sup> / <sub>4</sub> -6		10
	4.6	8	16	31	11	25	27.9	14	25	160514	QSL-V0- <sup>1</sup> / <sub>4</sub> -8		10
	6.2	10	19	36	11	30	31.4	17	36	160515	QSL-V0- <sup>1</sup> / <sub>4</sub> -10		10
	6.2	12	22.2	38	11	32	34.4	21	54	160516	QSL-V0- <sup>1</sup> / <sub>4</sub> -12		1
R <sup>3</sup> / <sub>8</sub>	4.6	8	16	32.8	12	26.5	27.9	17	38	160517	QSL-V0- <sup>3</sup> / <sub>8</sub> -8		10
	6.2	10	19	37	12	30.7	31.4	17	45	160518	QSL-V0- <sup>3</sup> / <sub>8</sub> -10		10
	7.7	12	22.2	39	12	32.7	34.4	21	54	160519	QSL-V0- <sup>3</sup> / <sub>8</sub> -12		1
R <sup>1</sup> / <sub>2</sub>	6.2	10	19	40	15	31.9	31.4	21	47	160520	QSL-V0- <sup>1</sup> / <sub>2</sub> -10		1
	7.7	12	22.2	42	15	33.9	34.4	21	70	160521	QSL-V0- <sup>1</sup> / <sub>2</sub> -12		1
<b>G 螺纹, 带密封圈</b>													
G <sup>1</sup> / <sub>8</sub>	3.6	6	14	24	5.1	-	24.9	13	15	186325	QSL-V0-G <sup>1</sup> / <sub>8</sub> -6		10
	4.6	8	16	27	5.1	-	27.9	14	19	186326	QSL-V0-G <sup>1</sup> / <sub>8</sub> -8		10
G <sup>1</sup> / <sub>4</sub>	3.6	6	14	25.5	5.6	-	24.9	17	25	186327	QSL-V0-G <sup>1</sup> / <sub>4</sub> -6		10
	4.6	8	16	28.5	5.6	-	27.9	17	27	186328	QSL-V0-G <sup>1</sup> / <sub>4</sub> -8		10
	6.2	10	19	32.5	5.6	-	31.4	17	33	186329	QSL-V0-G <sup>1</sup> / <sub>4</sub> -10		10
	6.2	12	22.2	34.5	5.6	-	34.4	21	53	186330	QSL-V0-G <sup>1</sup> / <sub>4</sub> -12		1
G <sup>3</sup> / <sub>8</sub>	4.6	8	16	30	6.6	-	27.9	19	40	186331	QSL-V0-G <sup>3</sup> / <sub>8</sub> -8		10
	6.2	10	19	34	6.6	-	31.4	19	43	186332	QSL-V0-G <sup>3</sup> / <sub>8</sub> -10		10
	7.7	12	22.2	36	6.6	-	34.4	21	47	186333	QSL-V0-G <sup>3</sup> / <sub>8</sub> -12		1
G <sup>1</sup> / <sub>2</sub>	8.2	10	19	37	7.6	-	31.4	24	69	186334	QSL-V0-G <sup>1</sup> / <sub>2</sub> -10		1
	7.7	12	22.2	39	7.6	-	34.4	24	72	186335	QSL-V0-G <sup>1</sup> / <sub>2</sub> -12		1

\* 包装单位数量

# 快插/螺纹接头 QS-V0, 阻燃型

技术参数

FESTO

## L形快插接头 QSL-V0

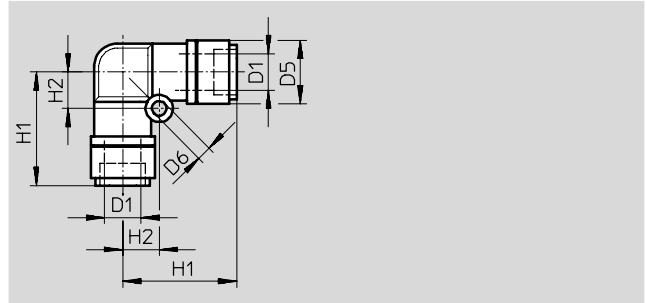

尺寸和订货数据										
气管外径	公称通径	D5	D6	H1	H2	每件重量	订货号	型号	PU*	
D1	[mm]	∅	∅			[g]				
4	2.3	12	3.2	22	6.5	6.4	132893	QSL-V0-4	· 新产品	10
6	3.6	14	3.2	25.2	8	8.7	160540	QSL-V0-6		10
8	4.6	16	4.2	27.6	10	13	160541	QSL-V0-8		10
10	6.2	19	4.2	31.4	12	20	160542	QSL-V0-10		10
12	7.7	22.2	4.2	34.4	14	29	160543	QSL-V0-12		10

\* 包装单位数量

# 快插/螺纹接头 QS-V0, 阻燃型

技术参数

## T形快插/螺纹接头 QST-V0

外螺纹  
带外六角



R 螺纹

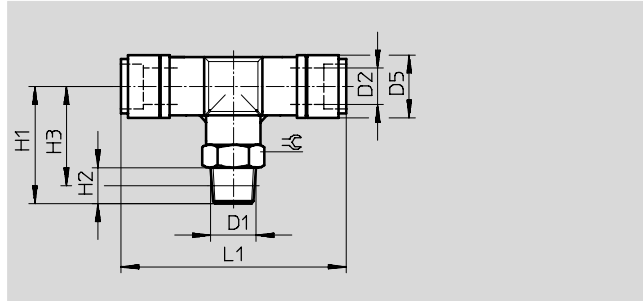

G 螺纹

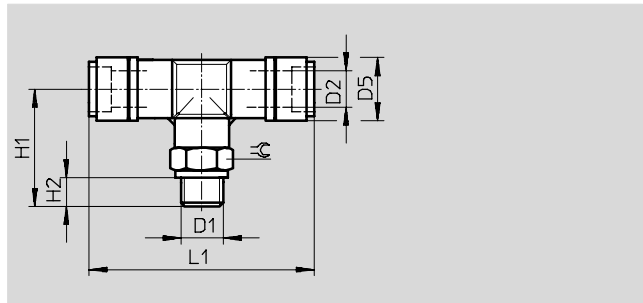

尺寸和订货数据													
接口	公称通径	气管外径	D5	H1	H2	H3	L1	≈	每件重量	订货号	型号	PU*	
D1	[mm]	D2	∅						[g]				
<b>R 螺纹</b>													
R1/8	2.3	4	12	23.2	8	19.2	44	10	15	132894	QST-V0-1/8-4	新产品	10
	3.6	6	14	26	8	22.1	50.5	12	19	160522	QST-V0-1/8-6		10
	4.6	8	16	29	8	22.4	55.2	14	24	160523	QST-V0-1/8-8		10
R1/4	3.6	6	14	29	11	23	50.5	14	27	160524	QST-V0-1/4-6		10
	4.6	8	16	29.3	11	23.3	55.2	14	30	160525	QST-V0-1/4-8		10
	6.2	10	19	36	11	30	60.8	17	44	160526	QST-V0-1/4-10		10
R3/8	6.2	12	22	38	11	32	66.8	21	63	160527	QST-V0-1/4-12		10
	4.6	8	16	31.1	12	24.8	55.2	17	43	160528	QST-V0-3/8-8		10
	6.2	10	19	37	12	30.7	60.8	17	53	160529	QST-V0-3/8-10		10
R1/2	7.7	12	22	39	12	32.7	66.8	21	63	160530	QST-V0-3/8-12		1
	6.2	10	19	40	15	31.9	60.8	21	74	160531	QST-V0-1/2-10		1
	7.7	12	22	42	15	33.9	66.8	21	81	160532	QST-V0-1/2-12		1
<b>G 螺纹, 带密封圈</b>													
G1/8	4.7	6	14	25	5.1	-	50.5	13	19	186336	QST-V0-G1/8-6		10
	5.4	8	16	25.3	5.1	-	55.2	14	23	186337	QST-V0-G1/8-8		10
G1/4	5.7	6	14	26.5	5.6	-	50.5	17	29	186338	QST-V0-G1/4-6		10
	6	8	16	26.8	5.6	-	55.2	17	32	186339	QST-V0-G1/4-8		10
	7.3	10	19	32.5	5.6	-	60.8	17	41	186340	QST-V0-G1/4-10		10
	8.8	12	22.2	34.5	5.6	-	66.8	21	64	186341	QST-V0-G1/4-12		10
G3/8	7.2	8	16	28.3	6.6	-	55.2	19	45	186342	QST-V0-G3/8-8		10
	8	10	19	34	6.6	-	60.8	19	51	186343	QST-V0-G3/8-10		10
	8.8	12	22.2	36	6.6	-	66.8	21	59	186344	QST-V0-G3/8-12		1
G1/2	9.6	10	19	37	7.6	-	60.8	24	77	186345	QST-V0-G1/2-10		1
	9.9	12	22.2	39	7.6	-	66.8	24	84	186346	QST-V0-G1/2-12		1

\* 包装单位数量



# 快插/螺纹接头 QS-V0, 阻燃型

技术参数

FESTO

## T形快插接头QST-V0

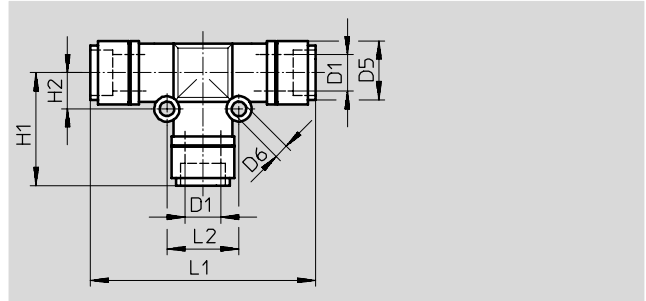

尺寸和订货数据												
气管外径	公称通径	D5	D6	H1	H2	L1	L2	每件重量	订货号	型号		PU*
D1	[mm]	∅	∅					[g]				
4	2.6	12	3.2	22	6.5	44	13	9.4	<b>132896</b>	<b>QST-V0-4</b>	· 新产品	<b>10</b>
6	4	14	3.2	25.15	8	50.3	16	14	<b>160533</b>	<b>QST-V0-6</b>		<b>10</b>
8	5	16	3.2	27.4	9	54.8	18	18	<b>160534</b>	<b>QST-V0-8</b>		<b>10</b>
10	6.7	19	4.2	30.4	12	60.8	24	28	<b>160535</b>	<b>QST-V0-10</b>		<b>10</b>
12	8.7	22.2	4.2	33.2	14	66.8	28	41	<b>160536</b>	<b>QST-V0-12</b>		<b>1</b>

\* 包装单位数量

## 快插/螺纹接头 QS

附件

FESTO

### 拆卸工具QS0

拆卸辅助工具，用于QS快插/螺纹接头



尺寸和订货数据			
气管外径	每件重量 [g]	订货号 型号	PU*
3 ... 10	13	158419 QS0	1

\* 包装单位数量