

Valve series VOFC

FESTO

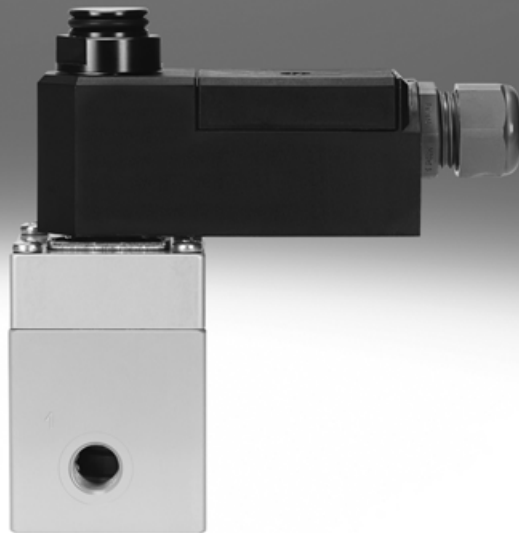

Solenoid valves VOFC

Key features

FESTO

General information

- The valves in the VOFC series are special 3/2-way and 5/2-way valves for process automation, for use within chemical and petrochemical systems, where they are frequently used as pilot valves for flaps and

drives. Their sturdy design and high resistance to corrosion make these valves suitable for outdoor use under harsh ambient conditions.

- The Namur flange pattern makes the solenoid valves especially suitable for quarter-turn actuators. The integrated spring chamber ventilation protects quarter-turn actuators with spring return

(single-acting cylinders and drives) against contaminated ambient air and weather influences such as rain.

- With German Technical Control Board (TÜV) report up to AK7/SIL-4.

Function, design

- 3/2-way or 5/2-way, single solenoid or double solenoid, depending on type.
- Piloted piston spool and piston poppet valves.

Sturdy

- The surface of the valve housing is treated with hard Ematal. This treatment involves converting the aluminium surface into a very hard aluminium oxide layer with titanium oxide intercalations and gives the valves very high resistance to wear and abrasion as well as first-class sliding qualities. This provides optimum protection against atmospheric and chemical influences.
- You can find information on the media resistance of the product at → www.festo.com.

Flexible in function

- The valve is easily modified for internal or external pilot air using a screw.
- Depending on the required function, the pressure connection is established independently of the working pressure as a pressure or vacuum connection.

Economical

- One type, one part number for two functions.
- Internal and external pilot air function integrated in one valve.
- One valve, two connection options.
- Port pattern to Namur for direct mounting of a drive as well as G and NPT threaded connections.

VOFC – Basic valves

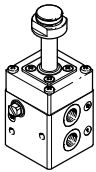

- 3/2-way, 5/2-way valves
- Connections G $\frac{1}{4}$, NPT $\frac{1}{4}$, G $\frac{1}{2}$
- Namur port pattern, optional with P channel

→ 6

VACC-S13 – Solenoid coils

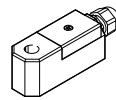

- AC and DC voltage 24V, 110V, 230V
- Type of explosion protection Ex emb II, Ex ia IIC

→ 32

VOFC – Solenoid valves

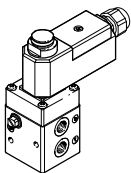

- Combination of basic valve VOFC and S13 coil VACC
- 3/2-way, 5/2-way valves
- Type of explosion protection Ex emb II

→ 24

VOFC – Accessories

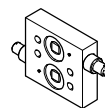

- Throttle plate
- Mounting plate
- Adapter with filter
- Hand lever

→ 3668

Solenoid valves VOFC

Peripherals overview

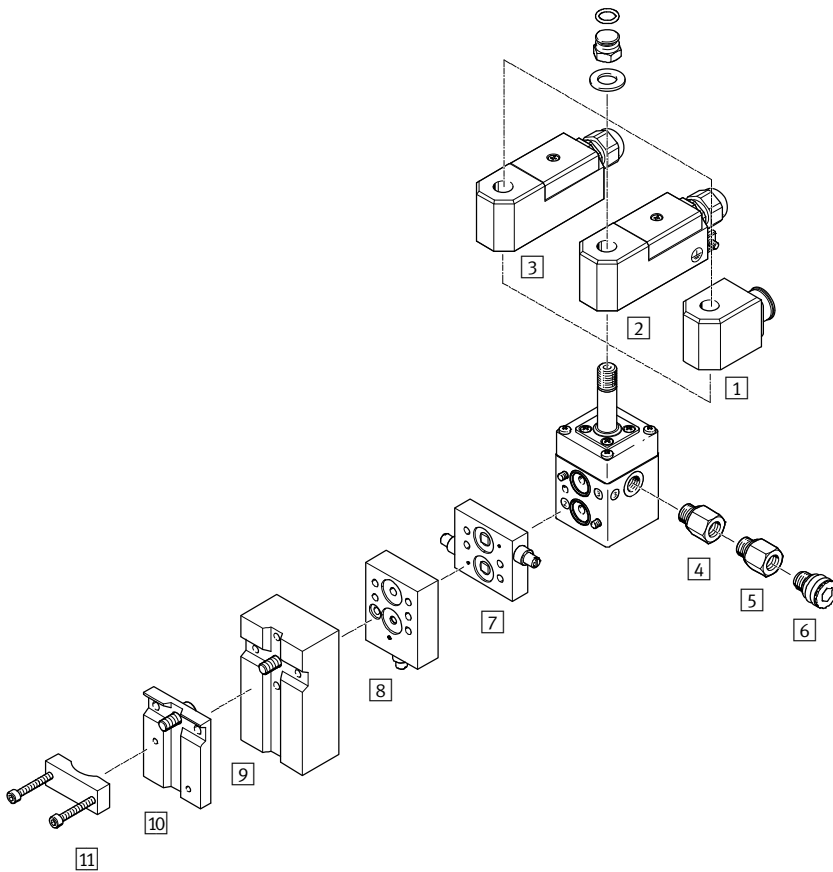

Mounting attachments and accessories		
	Brief description	→ Page/Internet
1	Solenoid coil VACC-S13 Standard magnet	32
2	Solenoid coil VACC-S13-me Ex-me magnet	34
3	Solenoid coil VACC-S13-A Ex-ia magnet	36
4	Adapter NPFV-AF-G14-N14-MF Adapter from G $\frac{1}{4}$ to NPT $\frac{1}{4}$, with filter	3670
5	Adapter NPFV-AF-G14-G14-MF Adapter from G $\frac{1}{4}$ to G $\frac{1}{4}$, with filter	3670
6	Exhaust protection VABD-D3-SN-G14 Exhaust protection to IP65. The spring chamber of drive 8 solenoid valve is protected against the ingress of aggressive ambient air and water by the one-way flow control system	3671
7	Flow control plate VABF-S7-F1B1P2-F Exhaust air flow control plate for Namur interface for installation between the solenoid valve and double-acting drives	3668
8	Flow control plate VABF-S7-F1B5P1-F Exhaust air flow control plate for Namur interface for installation between the solenoid valve and single-acting drives	3668
9	Connection plate kit VABF-S7-S-G14 Mounting plate for attaching the valve to a Namur	3669
10	Mounting plate VAME-S7-P Mounting plate for attaching the valve to a Namur rib	3669
11	Mounting bracket VAME-S7-Y Alternative option (instead of screw) of attaching the valve to a Namur rib with the help of a mounting bracket	3670

Solenoid valves VOFC

Type codes

FESTO

VOFC - L - B52 - M - Z - G12 - 1 - A1

Type

VOFC	Solenoid valve
------	----------------

Type of directional control valve

L	In-line valve
---	---------------

Valve function

B52	5/2-way valve, double solenoid
M32C	3/2-way valve, normally closed
M52	5/2-way valve, single solenoid

Reset method for single solenoid valves

M	Mechanical spring
---	-------------------

Pilot supply air

	Internal
Z	External
C	Internal/external pilot air

Pneumatic connection

G12	G $\frac{1}{2}$
G14	G $\frac{1}{4}$
N12	$\frac{1}{2}$ NPT
N14	$\frac{1}{4}$ NPT
FG12	Namur G $\frac{1}{2}$
FG14	Namur G $\frac{1}{4}$

Nominal operating voltage

	Without solenoid coil, not relevant
1	24 V DC
1U	24 V DC and AC
2A	110 V AC/50-60 Hz
2U	110 V DC and AC
3A	230 V AC/50-60 Hz
3U	230 V DC and AC

Electrical connection

A1	Port pattern type A, to EN 175 301
K4	Cable connector M20
F9	Armature tube for solenoid coil 13
F10	Armature tube for solenoid coil 18
K1	Cable

Solenoid valves VOFC

Type codes

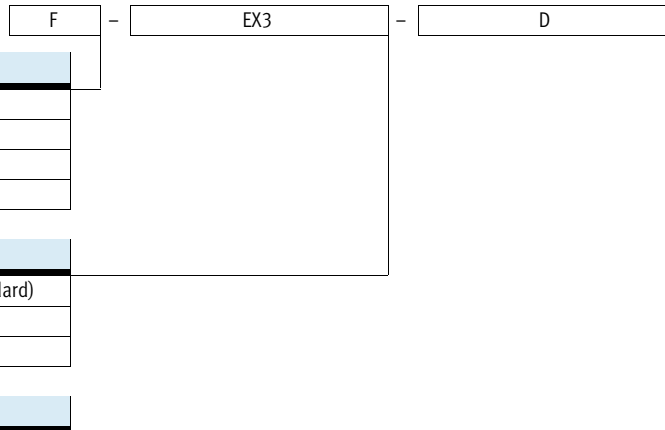

Protective circuit	
	None/standard
F	Fuse
FX	Fuse and freewheeling diode
X	Freewheeling diode

Approval EU, US	
	Approval defined upon introduction (standard)
Ex3	II 2G
Ex4	II 2GD

Type of explosion protection	
	None
D	Pressure-resistant casing
E	Enhanced safety
M	Moulded encapsulation
ME	Moulded encapsulation, enhanced safety
N	Non-sparking
Q	Sand casing
A	Intrinsically safe

Basic valves VOFC

Technical data – 3/2-way valves, G $\frac{1}{4}$ and Namur



Function
3/2-way valve

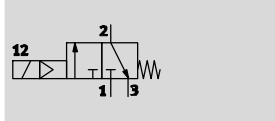

- - Temperature range
-25 ... +60 °C

- - Flow rate
600 l/min



General technical data		G $\frac{1}{4}$ basic valve, Namur	G $\frac{1}{4}$ Exi variant, for low ratings	G $\frac{1}{4}$ basic valve, Namur, P connection	G $\frac{1}{4}$ basic valve, for low ratings
Valve function		3/2-way closed, single solenoid			
Pneumatic connection	1	G $\frac{1}{4}$		Namur port pattern	
	2	G $\frac{1}{4}$ and Namur port pattern			
	3	G $\frac{1}{4}$			
	4	G $\frac{1}{4}$ and Namur port pattern			
Design	Piloted piston poppet valve				
Width	[mm]	51			
Mounting position	Any				
Duty cycle	100%				
Sealing principle	Soft				
Manual override	None				
Reset method	Mechanical spring				
Actuation type	Electrical				
Type of control	Piloted				
Pilot air supply	Internal				
Flow rate Kv pressurisation	[m 3 /h]	0.5			
Flow rate Kv exhausting	[m 3 /h]	0.65			
Direction of flow	Non-reversible				
Product weight	[g]	600		550	
Response time off	[ms]	12			
Response time on	[ms]	20			
Nominal size	[mm]	6			
Standard nominal flow rate	[l/min]	600			

Operating and environmental conditions		G $\frac{1}{4}$ basic valve	G $\frac{1}{4}$ Exi variant, for low ratings	G $\frac{1}{4}$ basic valve, Namur, P connection	G $\frac{1}{4}$ basic valve, for low ratings
Operating medium		Compressed air in accordance with ISO 8573-1:2010 [-:-:-]			
Protection class		IP65			
Operating pressure range	[bar]	2 ... 8			
Temperature of medium	[°C]	-25 ... +60			
Ambient temperature	[°C]	-25 ... +60			
Safety integrity level	[SIL]	Up to SIL 4 Low Demand mode			
		Up to SIL 4 High Demand mode			
Corrosion resistance class CRC ¹⁾		4			

1) Corrosion resistance class 4 according to Festo standard 940 070
Components with very heavy corrosion exposure. Components in contact with aggressive media, e.g. in food or chemical industries. These applications must, if necessary, be verified by special tests with the media concerned.

Basic valves VOFC

Technical data – 3/2-way valves, G $\frac{1}{4}$ and Namur

Materials

Sectional view

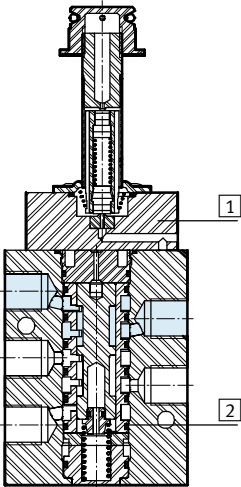

Solenoid valves	G $\frac{1}{4}$ basic valve	G $\frac{1}{4}$ Exi variant, for low ratings	G $\frac{1}{4}$ basic valve, Namur, P connection	G $\frac{1}{4}$ basic valve, for low ratings
1 Housing	Hard Ematal-anodised aluminium			
2 Seals	Nitrile rubber			
- Note on materials	Contains PWIS (paint-wetting impairment substances), RoHS-compliant			

Dimensions

Download CAD data → www.festo.com

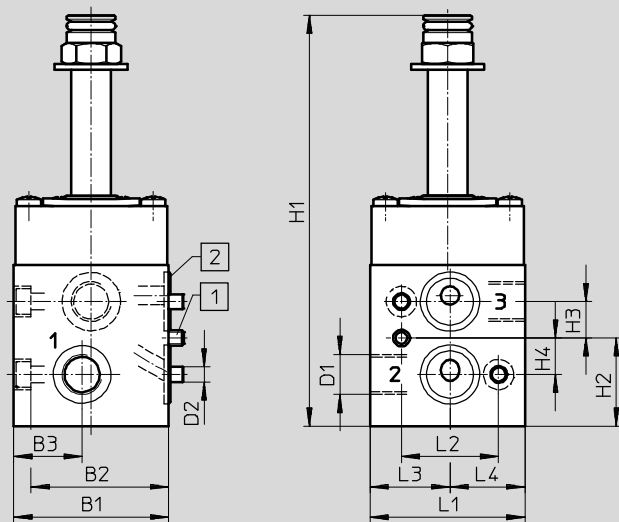

- 1 Coding pin M5x10
- 2 O-ring 16x2

Type	B1	B2	B3	D1	D2	H1	H2	H3	H4	L1	L2	L3	L4
VOFC-L-M32C-M-FG14-F9	51	45.3	22.5	G $\frac{1}{4}$	M5	135.3	29	12	12	51	32	26.3	24.7
VOFC-L-M32C-M-FG14-F9-A													

Basic valves VOFC

Technical data – 3/2-way valves, G $\frac{1}{4}$ and Namur

Dimensions

Download CAD data → www.festo.com

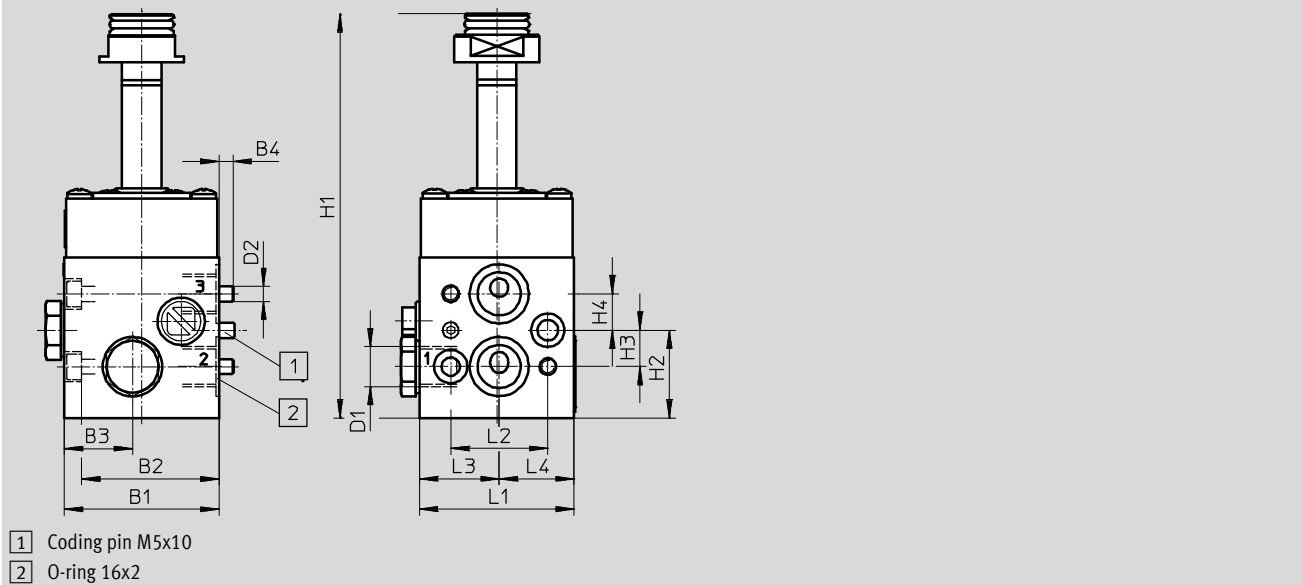

Type	B1	B2	B3	B4	D1	D2	H1	H2	H3	H4	L1	L2	L3	L4
VOFC-L-M32C-M-FGP14-F9	51	45.3	22.5	4.7	Namur G $\frac{1}{4}$	M5	133.4	29	12	12	51	32	26.3	24.7
VOFC-L-M32C-M-FGP14-F9-A														

Basic valves VOFC

Technical data – 3/2-way valves, G¹/₄

Function
3/2-way valve

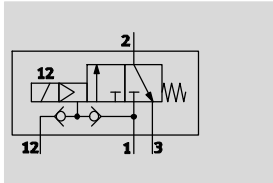

- - Temperature range
-25 ... +60 °C

- - Flow rate
600 l/min



General technical data		G ¹ / ₄ basic valve	G ¹ / ₄ Exi variant	NPT basic valve	NPT Exi variant
Type		G ¹ / ₄ basic valve	G ¹ / ₄ Exi variant	NPT basic valve	NPT Exi variant
Valve function		3/2-way closed, single solenoid			
Pneumatic connection	1	G ¹ / ₄	G ¹ / ₄	NPT ¹ / ₄ -18	NPT ¹ / ₄ -18
	2	G ¹ / ₄	G ¹ / ₄	-	-
	2	-	-	NPT ¹ / ₄ -18	NPT ¹ / ₄ -18
	3	G ¹ / ₄	G ¹ / ₄	NPT ¹ / ₄ -18	NPT ¹ / ₄ -18
	4	G ¹ / ₄	G ¹ / ₄	-	-
	4	-	-	NPT ¹ / ₄ -18	NPT ¹ / ₄ -18
Design		Piloted piston poppet valve			
Width	[mm]	51			
Mounting position		Any			
Duty cycle		100%			
Sealing principle		Soft			
Manual override		None			
Reset method		Mechanical spring			
Actuation type		Electrical			
Type of control		Piloted			
Pilot air supply		Internal, external			
Flow rate for piston valve pressurisation	[m ³ /h]	0.72			
		1.38			
Direction of flow		Non-reversible			
Product weight	[g]	550			
Response time off	[ms]	12			
Response time on	[ms]	20			
Nominal size	[mm]	6			
Standard nominal flow rate	[l/min]	900			

Operating and environmental conditions		G ¹ / ₄ basic valve	G ¹ / ₄ Exi variant	NPT basic valve	NPT Exi variant
Type		G ¹ / ₄ basic valve	G ¹ / ₄ Exi variant	NPT basic valve	NPT Exi variant
Operating medium		Compressed air in accordance with ISO 8573-1:2010 [--:--]			
Protection class		IP65			
Operating pressure range	[bar]	2 ... 8			
External operating pressure range	[bar]	0 ... 8			
Temperature of medium	[°C]	-25 ... +60			
Ambient temperature	[°C]	-25 ... +60			
Safety integrity level	[SIL]	Up to SIL 4 Low Demand mode			
		Up to SIL 4 High Demand mode			
Corrosion resistance class CRC ¹⁾		4			

1) Corrosion resistance class 4 according to Festo standard 940 070
Components with very heavy corrosion exposure. Components in contact with aggressive media, e.g. in food or chemical industries. These applications must, if necessary, be verified by special tests with the media concerned.

Basic valves VOFC

Technical data – 3/2-way valves, G¹/₄

Materials

Sectional view

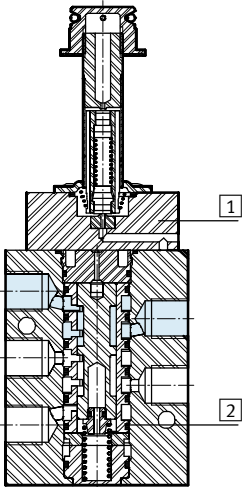

Solenoid valves	G ¹ / ₄ basic valve	G ¹ / ₄ Exi variant	NPT basic valve	NPT Exi variant
1 Housing	Hard Ematal-anodised aluminium			
2 Seals	Nitrile rubber			
- Note on materials	Contains PWIS (paint-wetting impairment substances), RoHS-compliant			

Dimensions

Download CAD data → www.festo.com

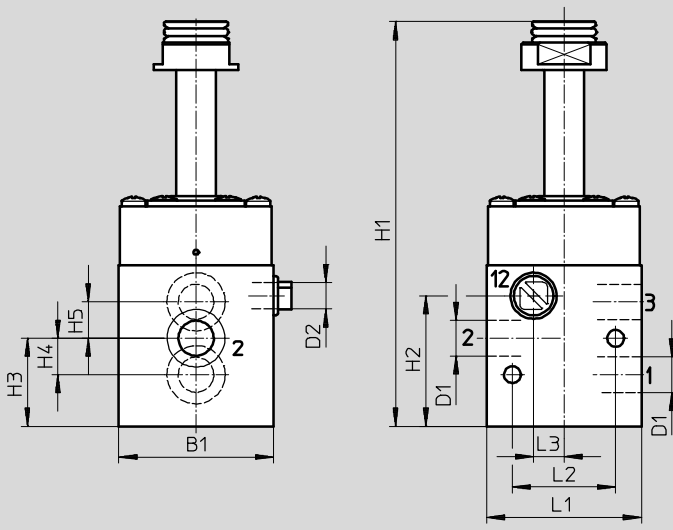

Type	B1	D1	D2	H1	H2	H3	H4	H5	L1	L2	L3
VOFC-L-M32C-MC-G14-F9	51	G ¹ / ₄	G ¹ / ₈	133	43	29	12	12	51	34	10
VOFC-L-M32C-MC-G14-F9-A											
VOFC-L-M32C-MC-N14-F9											
VOFC-L-M32C-MC-N14-F9-A											

Basic valves VOFC

Technical data – 3/2-way valves, G $\frac{1}{2}$ and Namur

Function
3/2-way valve

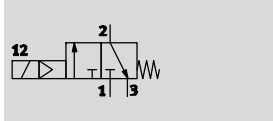

- - Temperature range
-25 ... +60 °C

- - Flow rate
3,000 l/min



General technical data		G $\frac{1}{2}$ basic valve	G $\frac{1}{2}$ Exi variant
Valve function		3/2-way closed, single solenoid	
Pneumatic connection	1	G $\frac{1}{2}$	
	2	G $\frac{1}{2}$ and Namur port pattern	
	3	G $\frac{1}{2}$	
	4	G $\frac{1}{2}$ and Namur port pattern	
Design		Piloted piston poppet valve	
Width	[mm]	51	
Mounting position		Any	
Duty cycle		100%	
Sealing principle		Soft	
Manual override		None	
Reset method		Mechanical spring	
Actuation type		Electrical	
Type of control		Piloted	
Pilot air supply		Internal	
Flow rate for piston valve pressurisation	[m ³ /h]	3.8	
Direction of flow		Non-reversible	
Product weight	[g]	880	
Response time off	[ms]	14	
Response time on	[ms]	25	
Nominal size	[mm]	12	
Standard nominal flow rate	[l/min]	3,000	

Operating and environmental conditions		G $\frac{1}{2}$ basic valve	G $\frac{1}{2}$ Exi variant
Operating medium		Compressed air in accordance with ISO 8573-1:2010 [--:--:--]	
Protection class		IP65	
Operating pressure range	[bar]	2 ... 8	
Temperature of medium	[°C]	-25 ... +60	
Ambient temperature	[°C]	-25 ... +60	
Corrosion resistance class CRC ¹⁾		4	

1) Corrosion resistance class 4 according to Festo standard 940 070
Components with very heavy corrosion exposure. Components in contact with aggressive media, e.g. in food or chemical industries. These applications must, if necessary, be verified by special tests with the media concerned.

Basic valves VOFC

Technical data – 3/2-way valves, G½ and Namur

Materials

Sectional view

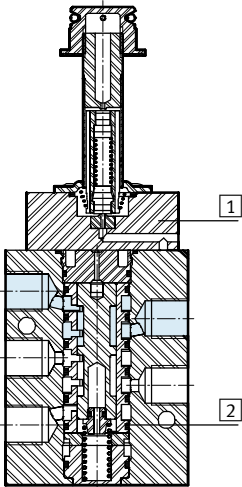

Solenoid valves	G½ basic valve	G½ Exi variant
1 Housing	Hard Ematal-anodised aluminium	
2 Seals	Nitrile rubber	
- Note on materials	Contains PWIS (paint-wetting impairment substances), RoHS-compliant	

Dimensions

Download CAD data → www.festo.com

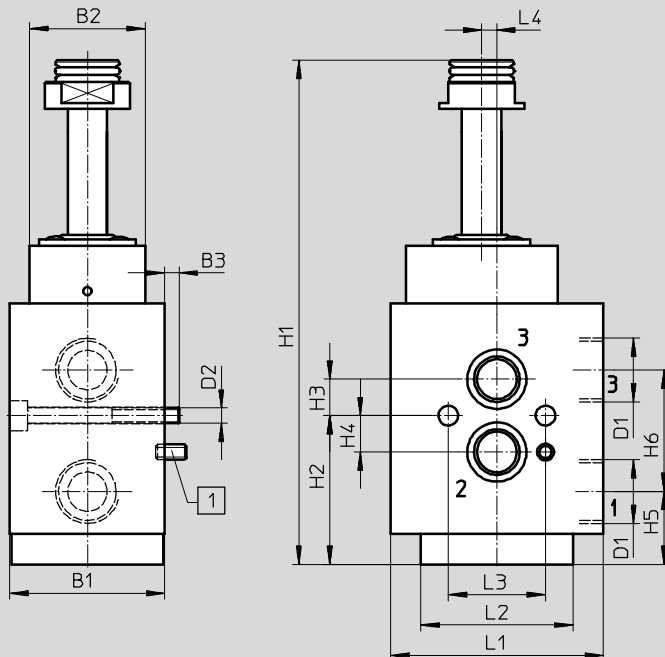

1 Coding pin M5x10

Type	B1	B2	B3	D1	D2	H1	H2	H3	H4	H5	H6	L1	L2	L3	L4
VOFC-L-M32C-M-FG12-F9	51	38	4.7	G½	M5	166	49	12	12	24	40	70	50	32	5
VOFC-L-M32C-M-FG12-F9-A															

Basic valves VOFC

Technical data – 3/2-way valves, G $\frac{1}{2}$

FESTO

Function
3/2-way valve

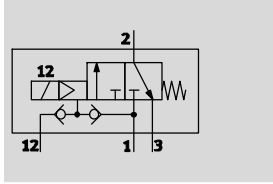

-  - Temperature range
-25 ... +60 °C

-  - Flow rate
3,000 l/min



General technical data		G $\frac{1}{2}$ basic valve	G $\frac{1}{2}$ Exi variant
Valve function		3/2-way closed, single solenoid	
Pneumatic connection	1	G $\frac{1}{2}$	
	2	G $\frac{1}{2}$	
	3	G $\frac{1}{2}$	
	4	G $\frac{1}{2}$	
Design		Piloted piston poppet valve	
Width	[mm]	51	
Mounting position		Any	
Duty cycle		100%	
Sealing principle		Soft	
Manual override		None	
Reset method		Mechanical spring	
Actuation type		Electrical	
Type of control		Piloted	
Pilot air supply		Internal, external	
Flow rate for piston valve pressurisation	[m 3 /h]	3.8	
Direction of flow		Non-reversible	
Product weight	[g]	880	
Response time off	[ms]	14	
Response time on	[ms]	25	
Nominal size	[mm]	12	
Standard nominal flow rate	[l/min]	3,000	

Operating and environmental conditions		Basic valve	Exi variant
Operating medium		Compressed air in accordance with ISO 8573-1:2010 [--:--:--]	
Protection class		IP65	
Operating pressure range	[bar]	2 ... 8	
External operating pressure range	[bar]	0 ... 8	
Temperature of medium	[°C]	-25 ... +60	
Ambient temperature	[°C]	-25 ... +60	
Corrosion resistance class CRC ¹⁾		4	

1) Corrosion resistance class 4 according to Festo standard 940 070
Components with very heavy corrosion exposure. Components in contact with aggressive media, e.g. in food or chemical industries. These applications must, if necessary, be verified by special tests with the media concerned.

Basic valves VOFC

Technical data – 3/2-way valves, G $\frac{1}{2}$

Materials

Sectional view

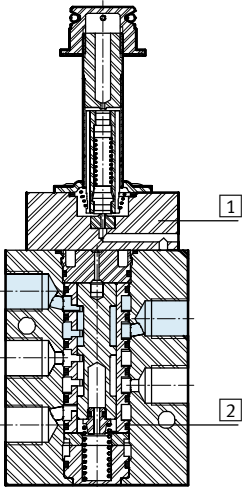

Solenoid valves	G $\frac{1}{2}$ basic valve	G $\frac{1}{2}$ Exi variant
1 Housing	Hard Ematal-anodised aluminium	
2 Seals	Nitrile rubber	
- Note on materials	Contains PWIS (paint-wetting impairment substances), RoHS-compliant	

Dimensions

Download CAD data → www.festo.com

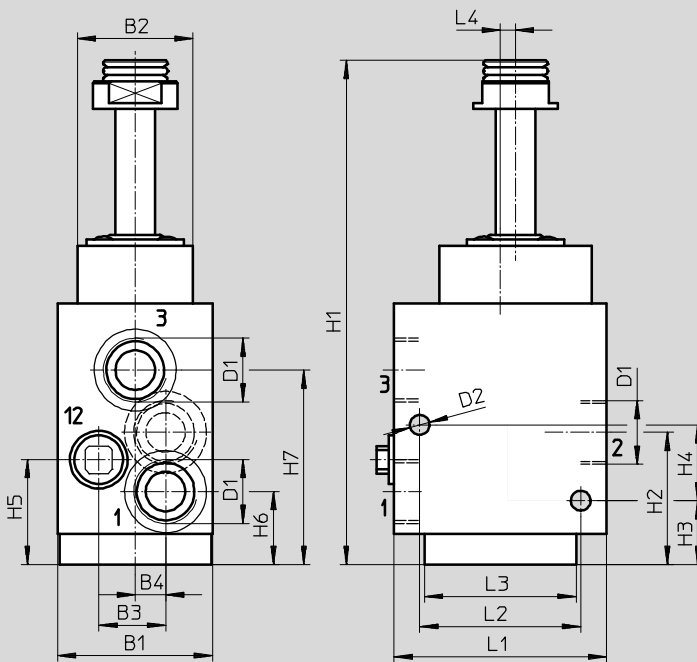

Type	B1	B2	B3	B4	D1	D2	H1	H2	H3	H4	H5	L1	L2	L3	L4
VOFC-L-M32C-MC-G12-F9															
VOFC-L-M32C-MC-G12-F9-A	51	37	22	10	G $\frac{1}{2}$	6.5	166	43.5	21	25	34.5	70	53	50	5

Basic valves VOFC

Technical data – 5/2-way valves, G $\frac{1}{4}$ and Namur

Function
5/2-way valve

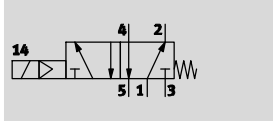

- - Temperature range
-25 ... +60 °C

- - Flow rate
750 l/min



General technical data		G $\frac{1}{4}$ basic valve	G $\frac{1}{4}$ Exi variant
Valve function		5/2-way, single solenoid	
Pneumatic connection	1	G $\frac{1}{4}$	
	2	G $\frac{1}{4}$ and Namur port pattern	
	3	G $\frac{1}{4}$	
	4	G $\frac{1}{4}$ and Namur port pattern	
Design	Hard piston spool valve		
Mounting position	Any		
Width	[mm]	40	
Duty cycle		100%	
Sealing principle		Hard	
Manual override		None	
Reset method		Mechanical spring	
Actuation type		Electrical	
Type of control		Piloted	
Pilot air supply		Internal	
Flow rate for piston valve pressurisation	[m ³ /h]	0.65	
Direction of flow		Non-reversible	
Product weight	[g]	620	
Response time off	[ms]	40	
Response time on	[ms]	24	
Nominal size	[mm]	6	
Standard nominal flow rate	[l/min]	750	

Operating and environmental conditions		G $\frac{1}{4}$ basic valve	G $\frac{1}{4}$ Exi variant
Operating medium		Compressed air in accordance with ISO 8573-1:2010 [---:-]	
Protection class		IP65	
Operating pressure range	[bar]	2 ... 8	
Temperature of medium	[°C]	-25 ... +60	
Ambient temperature	[°C]	-25 ... +60	
Corrosion resistance class CRC ¹⁾		4	

1) Corrosion resistance class 4 according to Festo standard 940 070
Components with very heavy corrosion exposure. Components in contact with aggressive media, e.g. in food or chemical industries. These applications must, if necessary, be verified by special tests with the media concerned.

Basic valves VOFC

Technical data – 5/2-way valves, G $\frac{1}{4}$ and Namur

Materials

Sectional view

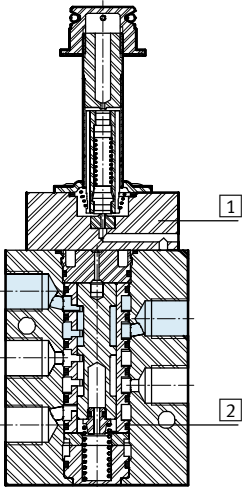

Solenoid valves	G $\frac{1}{4}$ basic valve	G $\frac{1}{4}$ Exi variant
1 Housing	Hard Ematal-anodised aluminium	
2 Seals	Nitrile rubber	
- Note on materials	Contains PWIS (paint-wetting impairment substances), RoHS-compliant	

Dimensions

Download CAD data → www.festo.com

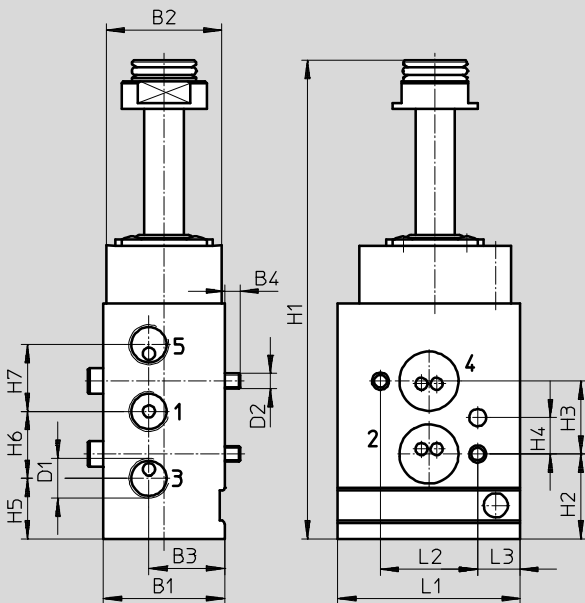

Type	B1	B2	B3	B4	D1	D2	H1	H2	H3	H4	H5	H6	H7	L1	L2	L3
VOFC-L-M52-M-FG14-F9	40	38	25	5	G $\frac{1}{4}$	M5	158	28	24	12	20	22	22	60	32	14
VOFC-L-M52-M-FG14-F9-A																

Basic valves VOFC

Technical data – 5/2-way valves, G $\frac{1}{4}$

Function
5/2-way valve

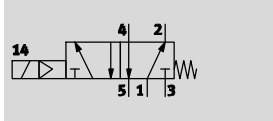

- - Temperature range
-25 ... +60 °C

- - Flow rate
850 l/min



General technical data		G $\frac{1}{4}$ basic valve	G $\frac{1}{4}$ Exi variant
Valve function		5/2-way single solenoid	
Pneumatic connection	1	G $\frac{1}{4}$	
	2	G $\frac{1}{4}$	
	3	G $\frac{1}{4}$	
	4	G $\frac{1}{4}$	
Design	Hard piston spool valve		
Mounting position	Any		
Width	[mm]	40	
Duty cycle		100%	
Sealing principle		Hard	
Manual override		None	
Reset method		Mechanical spring	
Actuation type		Electrical	
Type of control		Piloted	
Pilot air supply		Internal	
Flow rate for piston valve pressurisation	[m 3 /h]	0.65	
Direction of flow		Non-reversible	
Product weight	[g]	620	
Response time off	[ms]	40	
Response time on	[ms]	24	
Nominal size	[mm]	6	
Standard nominal flow rate	[l/min]	850	

Operating and environmental conditions		G $\frac{1}{4}$ basic valve	G $\frac{1}{4}$ Exi variant
Operating medium		Compressed air in accordance with ISO 8573-1:2010 [---:--]	
Protection class		IP65	
Operating pressure range	[bar]	2 ... 8	
Temperature of medium	[°C]	-25 ... +60	
Ambient temperature	[°C]	-25 ... +60	
Corrosion resistance class CRC ¹⁾		4	

1) Corrosion resistance class 4 according to Festo standard 940 070
Components with very heavy corrosion exposure. Components in contact with aggressive media, e.g. in food or chemical industries. These applications must, if necessary, be verified by special tests with the media concerned.

Basic valves VOFC

Technical data – 5/2-way valves, G $\frac{1}{4}$

Materials

Sectional view

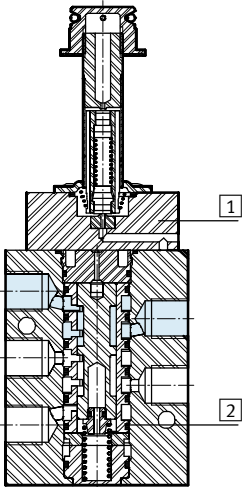

Solenoid valves	G $\frac{1}{4}$ basic valve	G $\frac{1}{4}$ Exi variant
1 Housing	Hard Ematal-anodised aluminium	
2 Seals	Nitrile rubber	
- Note on materials	Contains PWIS (paint-wetting impairment substances), RoHS-compliant	

Dimensions

Download CAD data → www.festo.com

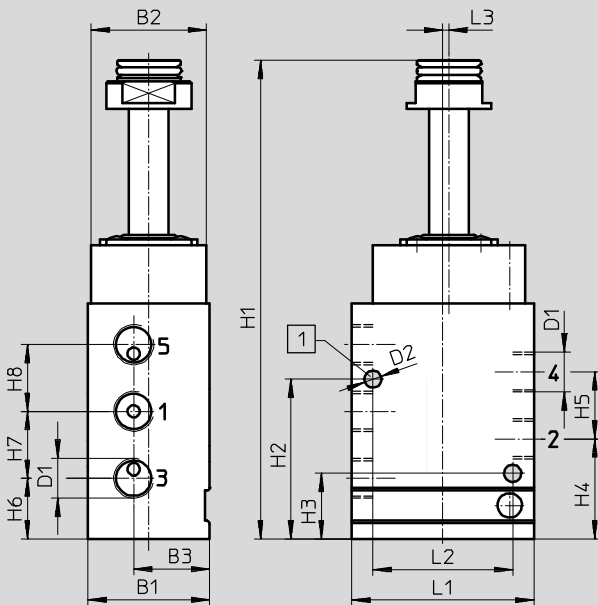

1 Coding pin M5x10

Type	B1	B2	B3	D1	D2	H1	H2	H3	H4	H5	H6	H7	H8	L1	L2
VOFC-L-M52M-G14-F9	40	38	25	G $\frac{1}{4}$	M5	158	52.6	21.6	33	22	20	22	22	60	46
VOFC-L-M52M-G14-F9-A															

Basic valves VOFC

Technical data – 5/2-way valves, G $\frac{1}{4}$, NAMUR

Function
5/2-way valve

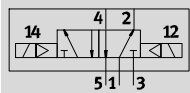

- - Temperature range
-25 ... +60 °C

- - Flow rate
750, 850 l/min



General technical data		G $\frac{1}{4}$, NAMUR	G $\frac{1}{4}$
Valve function		5/2-way, double solenoid	
Pneumatic connection	1	G $\frac{1}{4}$	
	2	NAMUR port pattern	G $\frac{1}{4}$
	3	G $\frac{1}{4}$	
	4	NAMUR port pattern	G $\frac{1}{4}$
Design	Soft-piston slide valve		
Mounting position	Any		
Width	[mm]	40	
Duty cycle	[%]	100	
Sealing principle	Soft		
Manual override	None		
Actuation type	Electric		
Type of control	Piloted		
Pilot air supply	Internal		
Flow rate for piston valve pressurisation	[m 3 /h]	0.65	
Flow rate for piston valve exhausting	[m 3 /h]	0.65	
Direction of flow	Non-reversible		
Product weight	[g]	790	
Switching time off	[ms]	40	20
Switching time on	[ms]	24	20
Max. switching frequency	[Hz]	1	
Nominal size	[mm]	6	
Standard nominal flow rate	[l/min]	750	850

Operating and environmental conditions		G $\frac{1}{4}$, NAMUR	G $\frac{1}{4}$
Operating medium		Compressed air in accordance with ISO 8573-1:2010 [-:-:-]	
Protection class		IP65	
Operating pressure range	[bar]	2 ... 8	
Temperature of medium	[°C]	-25 ... +60	
Ambient temperature	[°C]	-25 ... +60	
Safety integrity level	[SIL]	Up to SIL 2 Low Demand mode	
		Up to SIL 2 High Demand mode	
Corrosion resistance class CRC ¹⁾		4	

1) Corrosion resistance class 4 according to Festo standard 940 070
Components subject to particularly high corrosion stress. Parts used with aggressive media, e.g. in the food or chemical industry. These applications should be supported with special tests with the media if required.

Basic valves VOFC

Technical data – 5/2-way valves, G $\frac{1}{4}$, NAMUR

Materials

Sectional view

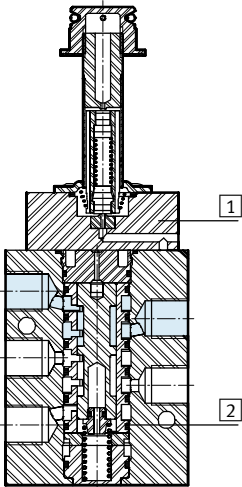

Solenoid valves	G $\frac{1}{4}$, NAMUR	G $\frac{1}{4}$
1 Housing	Hard Ematal-anodised aluminium	
2 Seals	NBR	
- Note on materials	Contains PWIS (paint-wetting impairment substances), RoHS-compliant	

Basic valves VOFC

Technical data – 5/2-way valves, G $\frac{1}{4}$, NAMUR

Dimensions

Download CAD data → www.festo.com

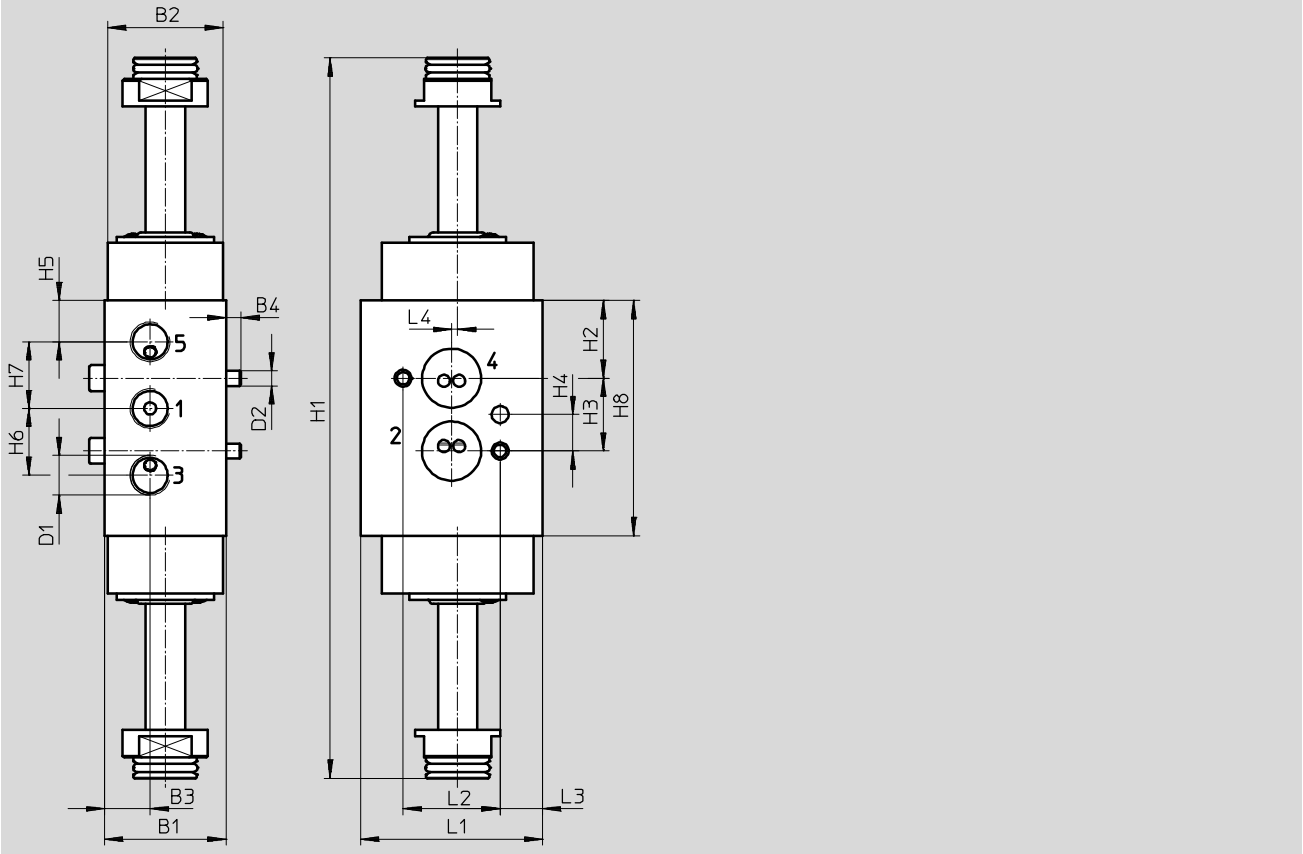

Type	B1	B2	B3	B4	D1	D2	H1	H2	H3	H4	H5	H6	H7	H8	L1	L2	L3	L4
VOFC-L-B52-FG14-F9	40	38	15	5	G $\frac{1}{4}$	M5	237.6	25.6	24	12	13.6	22	22	77.6	60	32	14	2
VOFC-L-B52-FG14-F9-A																		

Basic valves VOFC

Technical data – 5/2-way valves, G $\frac{1}{4}$, NAMUR

Dimensions

Download CAD data → www.festo.com

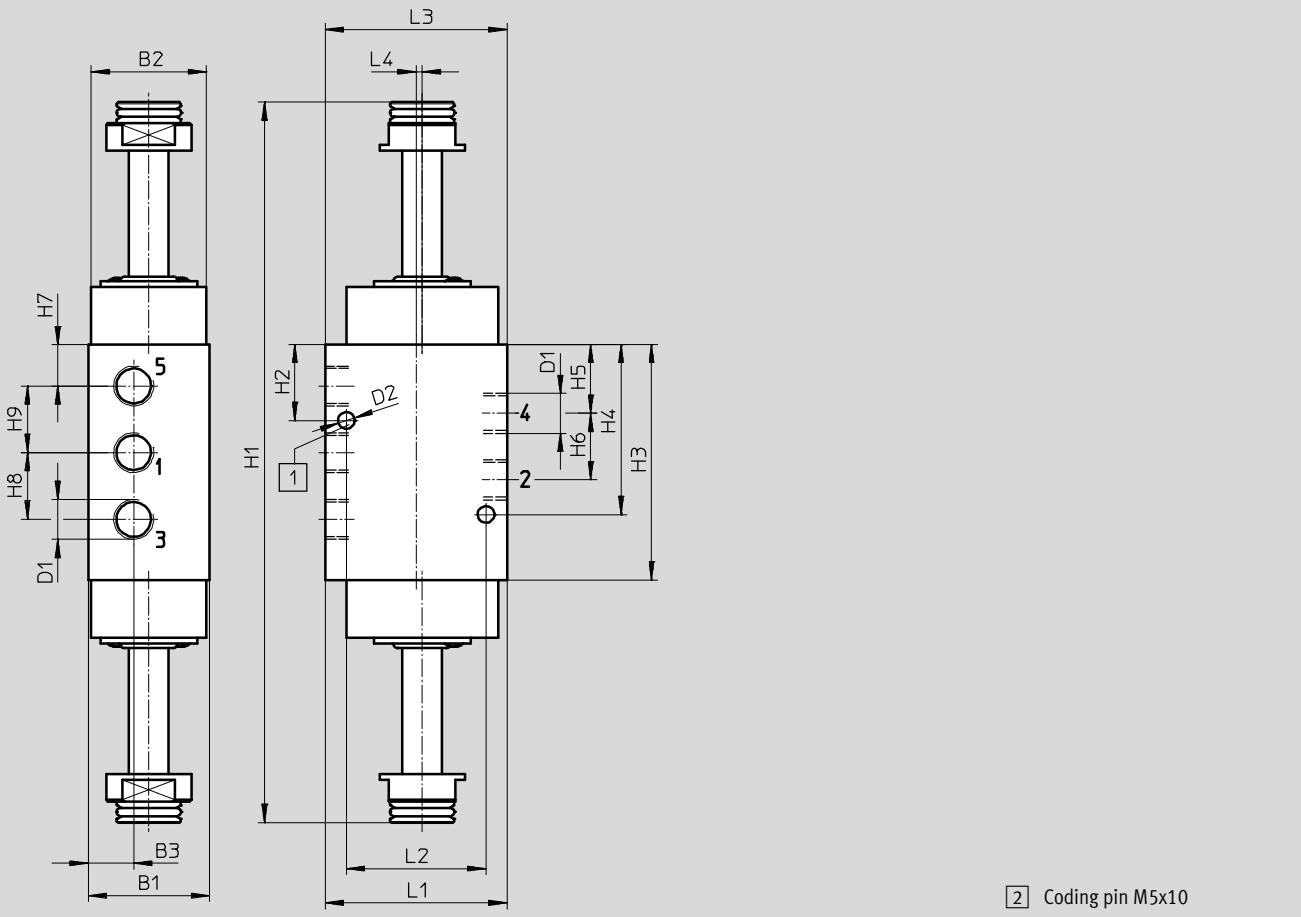

Type	B1	B2	B3	D1	D2	H1	H2	H3	H4	H5	H6	H7	H8	H9	L1	L2	L3	L4
VOFC-L-B52-G14-F9	40	38	15	G $\frac{1}{4}$	5.5	240	25	77.6	56	22.6	22	13.6	22	22	60	46	60	2
VOFC-L-B52-G14-F9-A																		

Basic valves VOFC

Technical data

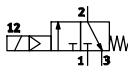
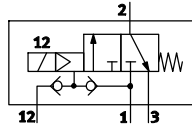
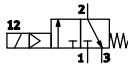
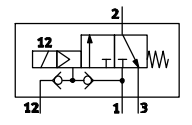
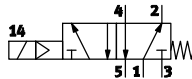
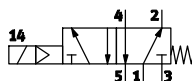
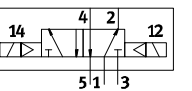
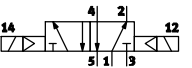
Ordering data					
Circuit symbol	Function	Pneumatic connection	Pilot air supply	Part No.	Type
In-line valve					
	3/2-way, closed, single solenoid	G $\frac{1}{4}$ and NAMUR	Internal	562857	VOFC-L-M32C-M-FG14-F9
				562858	VOFC-L-M32C-M-FG14-F9-A
		G $\frac{1}{4}$ and NAMUR, P connection		570787	VOFC-L-M32C-M-FGP14-F9
		G $\frac{1}{4}$ and NAMUR, P connection		570788	VOFC-L-M32C-M-FGP14-F9-A
	3/2-way, closed, single solenoid	G $\frac{1}{4}$	Internal, external	562859	VOFC-L-M32C-MC-G14-F9
			Internal, external	562860	VOFC-L-M32C-MC-G14-F9-A
			Internal, external	562861	VOFC-L-M32C-MC-N14-F9
			Internal, external	562862	VOFC-L-M32C-Mc-N14-F9-A
	3/2-way, closed, single solenoid	G $\frac{1}{2}$ and NAMUR	Internal	562863	VOFC-L-M32C-M-FG12-F9
				562864	VOFC-L-M32C-M-FG12-F9-A
	3/2-way, closed, single solenoid	G $\frac{1}{2}$	Internal, external	562865	VOFC-L-M32C-MC-G12-F9
				562866	VOFC-L-M32C-MC-G12-F9-A
	5/2-way, single solenoid	G $\frac{1}{4}$ and NAMUR	Internal	2823469	VOFC-L-M52-M-FG14-F9
				2823470	VOFC-L-M52-M-FG14-F9-A
	5/2-way, single solenoid	G $\frac{1}{4}$	Internal	2823467	VOFC-L-M52-M-G14-F9
				2823468	VOFC-L-M52-M-G14-F9-A
 	5/2-way, double solenoid	G $\frac{1}{4}$ and NAMUR	Internal	2821302	VOFC-L-B52-FG14-F9
		G $\frac{1}{4}$ and NAMUR		2821303	VOFC-L-B52-FG14-F9-A
		G $\frac{1}{4}$		2820406	VOFC-L-B52-G14-F9
		G $\frac{1}{4}$		2820407	VOFC-L-B52-G14-F9-A



Solenoid valves VOFC

FESTO

Technical data – 3/2-way valve with ignition protection type Ex-me

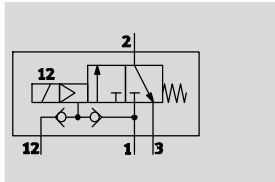
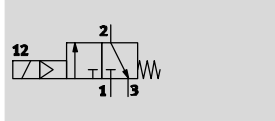
Function
3/2-way valve



-  - Temperature range
-25 ... +60 °C
-  - Flow rate
600 l/min
-  - Voltage
14 ... 32 V DC

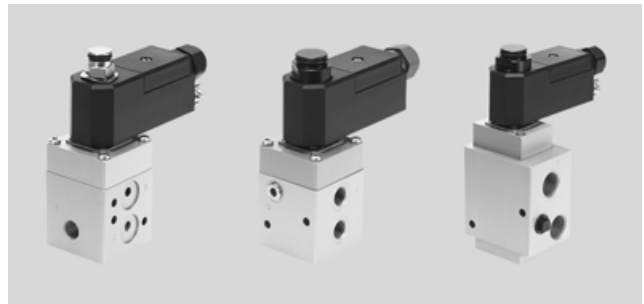

General technical data		G ¹ / ₄ and Namur	G ¹ / ₄	NPT ¹ / ₄	G ¹ / ₂
Valve function		3/2-way closed, single solenoid			
Pneumatic connection	1	G ¹ / ₄		NPT ¹ / ₄ -18	G ¹ / ₂
	2	G ¹ / ₄		-	G ¹ / ₂
	2	Namur port pattern	-	NPT ¹ / ₄ -18	-
	3	G ¹ / ₄		NPT ¹ / ₄ -18	G ¹ / ₂
	4	Namur port pattern	G ¹ / ₄	NPT ¹ / ₄ -18	G ¹ / ₂
Width		51 mm			
Design		Piloted piston poppet valve			
Mounting position		Any			
Duty cycle		100%			
Sealing principle		Soft			
Manual override		None			
Reset method		Mechanical spring			
Actuation type		Electrical			
Type of control		Piloted			
Pilot air supply		Internal	Internal, external	Internal, external	Internal, external
Flow rate for piston valve pressurisation	[m ³ /h]	0.5	0.72	0.72	3.8
		0.65	1.38	1.38	3.8
Direction of flow		Non-reversible			
Electrical connection		Terminal box, cable entry thread M20x1.5			
Reset method		Mechanical spring			
Product weight	[g]	930	880	880	1,210
Response time off	[ms]	12			
Response time on	[ms]	20			
Nominal size	[mm]	6			
Standard nominal flow rate	[l/min]	600	900	900	3,000

Solenoid valves VOFC

Technical data – 3/2-way valve with ignition protection type Ex-me

Electrical data		G $\frac{1}{4}$ and Namur	G $\frac{1}{4}$	NPT $\frac{1}{4}$	G $\frac{1}{2}$
Permissible voltage fluctuations	[%]	-15 ... +10			
Max. input power	[W]	-			
Max. input voltage	[V]	-			
Max. input current	[A]	-			
Required current consumption	[mA]	-			
Coil characteristics	DC voltage 24 V	[W]	1.8		
	AC voltage 24 V	[VA]	1.8		

Operating and environmental conditions		G $\frac{1}{4}$ and Namur	G $\frac{1}{4}$	NPT $\frac{1}{4}$	G $\frac{1}{2}$
Operating medium		Compressed air in accordance with ISO 8573-1:2010 [-:-:-]			
Protection class		IP65			
Operating pressure range	[bar]	2 ... 8			
External operating pressure range	[bar]	-	0 ... 8		
Temperature of medium	[°C]	-25 ... 60			
ATEX category for gas		II 2G			
ATEX category for dust		II 2D			
Explosion ignition protection type for gas		Ex emb II T6, T5			
Explosion ignition protection type for dust		Ex tD A21 IP65 T80°C, T95°C			
Explosion-proof temperature rating	T5:	-20°C ≤ Ta ≤ +60°C			
	T6:	-20°C ≤ Ta ≤ +50°C			
	T80°C:	-20°C ≤ Ta ≤ +50°C			
	T95°C:	-20°C ≤ Ta ≤ +60°C			
Certificate issuing authority		PTB 08 ATEX 2042 X			
CE mark (see declaration of conformity)		To EU Explosion Protection Directive (ATEX)			
Safety integrity level	[SIL]	Up to SIL 4 Low Demand mode			-
		Up to SIL 4 High Demand mode			-
Corrosion resistance class CRC ¹⁾		4			

1) Corrosion resistance class 4 according to Festo standard 940 070
 Components with very heavy corrosion exposure. Components in contact with aggressive media, e.g. in food or chemical industries. These applications must, if necessary, be verified by special tests with the media concerned.

Solenoid valves VOFC

Technical data – 3/2-way valve with ignition protection type Ex-me

Materials

Sectional view

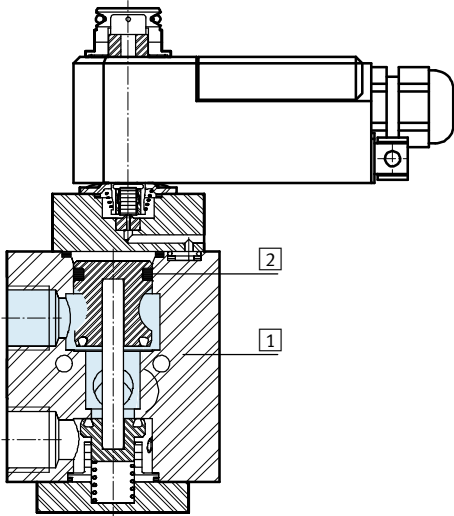

Solenoid valves	G $\frac{1}{4}$ and Namur	G $\frac{1}{4}$	NPT $\frac{1}{4}$	G $\frac{1}{2}$
1 Housing	Hard Ematal-anodised aluminium			
2 Seals	Nitrile rubber			
- Note on materials	Contains PWIS (paint-wetting impairment substances), RoHS-compliant			

Dimensions

Download CAD data → www.festo.com

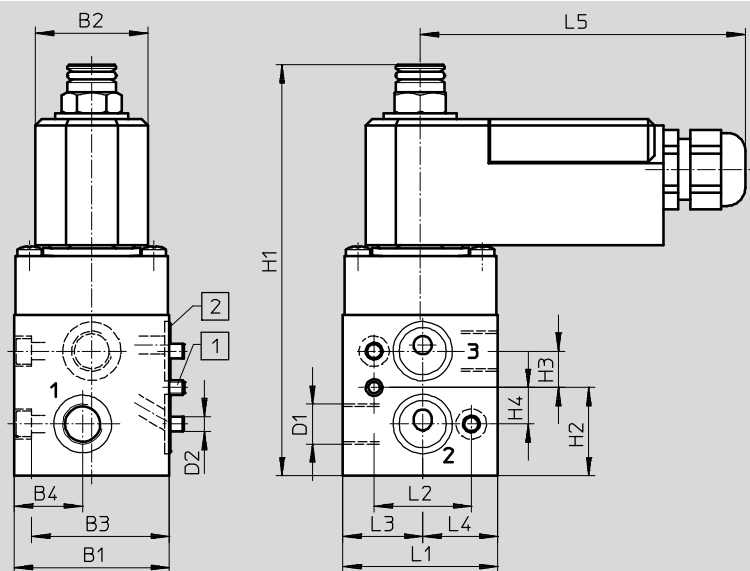

- 1 Coding pin M5x10
- 2 O-ring 16x2

Type	B1	B2	B3	B4	D1	D2	H1	H2	H3	H4	L1	L2	L3	L4	L5
VOFC-L-M32C-M-FG14-1UK4-Ex4me	51	37	45.3	22.5	G $\frac{1}{4}$	M5	135.3	29	12	12	51	32	26.3	24.7	107

Solenoid valves VOFC

Technical data – 3/2-way valve with ignition protection type Ex-me

Dimensions

Download CAD data → www.festo.com

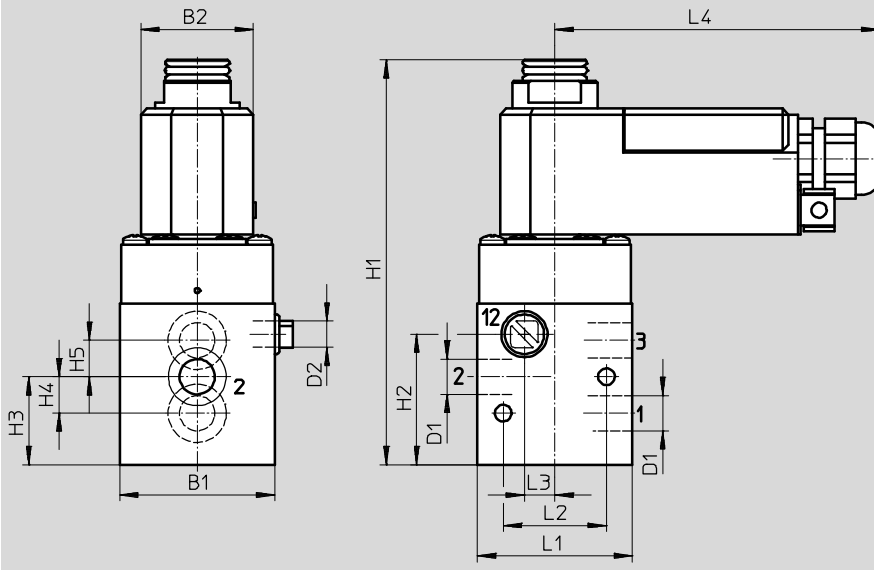

Type	B1	B2	D1	D2	H1	H2	H3	H4	H5	L1	L2	L3	L4
VOFC-L-M32C-MC-G14-1UK4-Ex4me	51	37	G1/4	G1/8	133	43	29	12	12	51	34	10	107
VOFC-L-M32C-MC-N14-1UK													

Dimensions

Download CAD data → www.festo.com

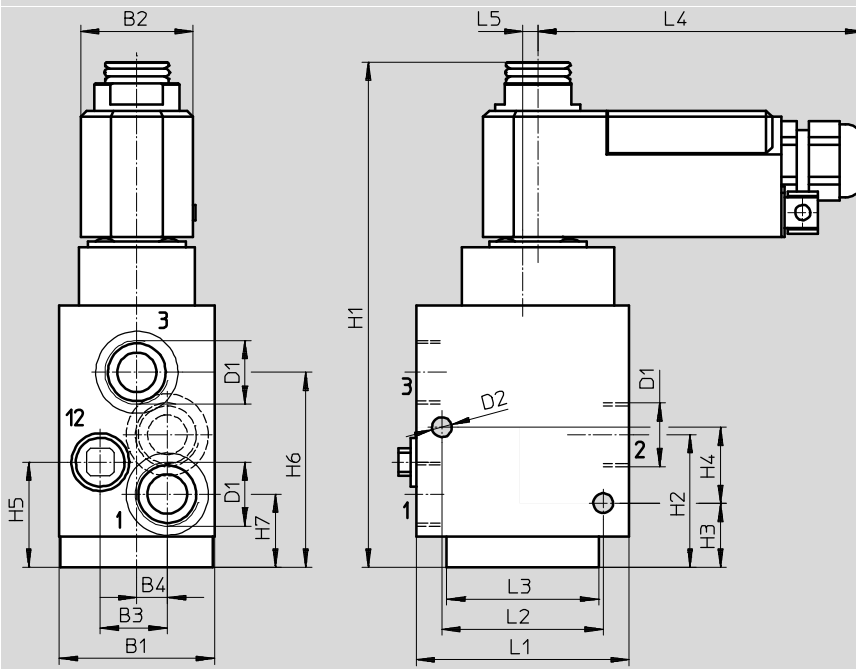

Type	B1	B2	B3	B4	D1	D2	H1	H2	H3	H4	H5	L1	L2	L3	L4	L5
VOFC-L-M32C-MC-G12-1UK4-Ex4me	51	37	22	10	G1/2	6.5	166	43.5	21	25	34.5	70	53	50	107	5



Solenoid valves VOFC

Technical data – 3/2-way valve with ignition protection type Ex-ia

FESTO

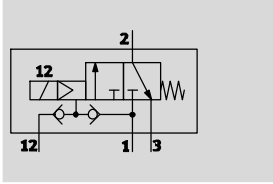
Function
3/2-way valve



-  - Temperature range
-25 ... +60 °C
-  - Flow rate
600 ... 900 l/min
-  - Voltage
14 ... 32 V DC



General technical data		G $\frac{1}{4}$ and Namur	G $\frac{1}{4}$
Valve function		3/2-way closed, single solenoid	
Pneumatic connection	1	G $\frac{1}{4}$	
	2	G $\frac{1}{4}$	
	2	Namur port pattern	-
	3	G $\frac{1}{4}$	
Width	[mm]	51	
Design		Piloted piston poppet valve	
Mounting position		Any	
Duty cycle		100%	
Sealing principle		Soft	
Manual override		None	
Reset method		Mechanical spring	
Actuation type		Electrical	
Type of control		Piloted	
Pilot air supply		Internal	Internal, external
Flow rate for piston valve pressurisation	[m 3 /h]	0.5	0.72
		0.65	1.38
Direction of flow		Non-reversible	
Electrical connection		Terminal box, cable entry thread M20x1.5	
Reset method		Mechanical spring	
Product weight	[g]	930	880
Response time off	[ms]	12	
Response time on	[ms]	20	
Nominal size	[mm]	6	
Standard nominal flow rate	[l/min]	600	900

Electrical data		G $\frac{1}{4}$ and Namur	G $\frac{1}{4}$
Permissible voltage fluctuations	[%]	-15 ... +10	-
Max. input power	[W]	1.2	
Max. input voltage	[V]	32	
Max. input current	[A]	0.2	
Required current consumption	[mA]	16	
Coil characteristics	DC voltage 24 V	[V]	14 ... 32

Solenoid valves VOFC

Technical data – 3/2-way valve with ignition protection type Ex-ia

Operating and environmental conditions		G $\frac{1}{4}$ and Namur	G $\frac{1}{4}$
Operating medium		Compressed air in accordance with ISO 8573-1:2010 [-:-:-]	
Protection class		IP65	
Operating pressure range	[bar]	2 ... 8	
External operating pressure range	[bar]	–	0 ... 8
Temperature of medium	[°C]	–25 ... 60	
ATEX category for gas		II 2G	
Explosion ignition protection type for gas		Ex ia IIC T6, T5	
Explosion-proof temperature rating	T5:	–30°C ≤ Ta ≤ +65°C	
	T6:	–30°C ≤ Ta ≤ +50°C	
	T80°C:	–20°C ≤ Ta ≤ +50°C	
	T95°C:	–20°C ≤ Ta ≤ +60°C	
Certificate issuing authority		PTB 08 ATEX 2038	
CE mark (see declaration of conformity)		To EU Explosion Protection Directive (ATEX)	
Safety integrity level	[SIL]	Up to SIL 4 Low Demand mode	
		Up to SIL 4 High Demand mode	
Corrosion resistance class CRC ¹⁾		4	

- 1) Corrosion resistance class 4 according to Festo standard 940 070
 Components with very heavy corrosion exposure. Components in contact with aggressive media, e.g. in food or chemical industries. These applications must, if necessary, be verified by special tests with the media concerned.

Materials

Sectional view

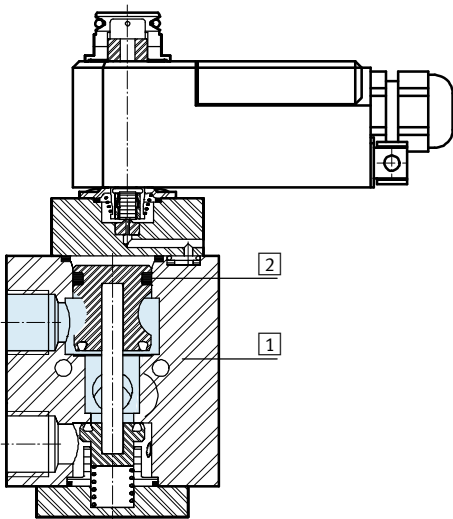

Solenoid valves		G $\frac{1}{4}$ and Namur	G $\frac{1}{4}$
1	Housing	Hard Ematal-anodised aluminium	
2	Seals	Nitrile rubber	
–	Note on materials	Contains PWIS (paint-wetting impairment substances), RoHS-compliant	

Solenoid valves VOFC

Technical data – 3/2-way valve with ignition protection type Ex-ia

Dimensions

Download CAD data → www.festo.com

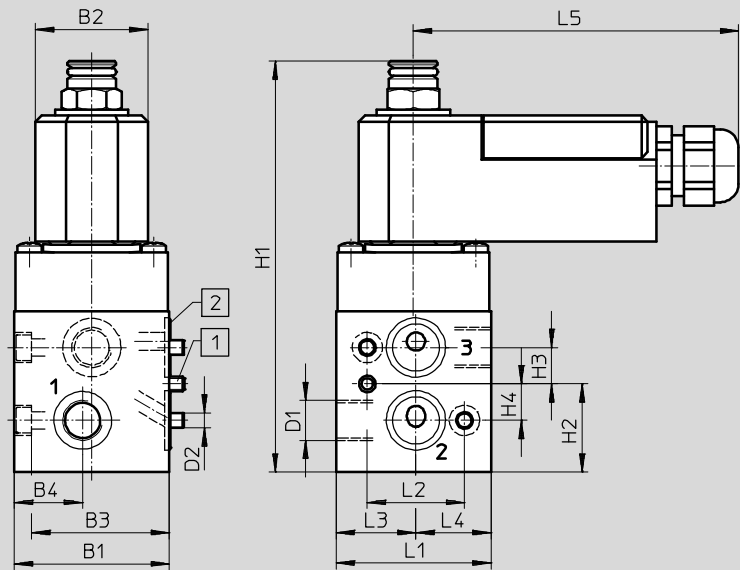

- 1 Coding pin M5x10
- 2 O-ring 16x2

Type	B1	B2	B3	B4	D1	D2	H1	H2	H3	H4	L1	L2	L3	L4	L5
VOFC-L-M32C-M-FG14-1K4-EX3A	51	37	45.3	22.5	G $\frac{1}{4}$	M5	135.3	29	12	12	51	32	26.3	24.7	107

Dimensions

Download CAD data → www.festo.com

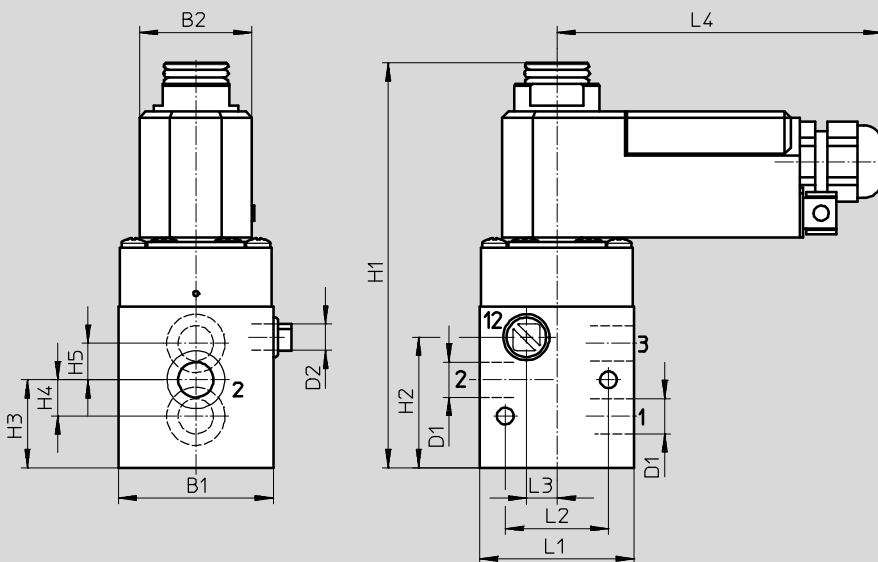

Type	B1	B2	D1	D2	H1	H2	H3	H4	H5	L1	L2	L3	L4
VOFC-L-M32C-MC-G14-1K4-EX3A	51	37	G $\frac{1}{4}$	G $\frac{1}{8}$	133	43	29	12	12	51	34	10	107

Solenoid valves VOFC

Technical data – 3/2-way valve with ignition protection type Ex-ia

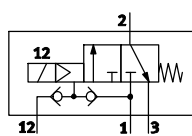
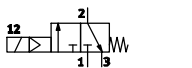
Ordering data						
Circuit symbol	Function	Size	Explosion ignition protection type for gas	Pilot air supply	Part No.	Type
	3/2-way closed, single solenoid	G $\frac{1}{4}$	Ex emb II T $_6$, T $_5$	Internal, external	562 877	VOFC-L-M32C-MC-G14-1UK4-Ex4me
		G $\frac{1}{4}$	Ex ia IIC T $_6$, T $_5$	Internal, external	562 878	VOFC-L-M32C-MC-G14-1K4-Ex3A
		NPT $\frac{1}{4}$	Ex emb II T $_6$, T $_5$	Internal	562 879	VOFC-L-M32C-M-N14-1UK4-Ex4me
		G $\frac{1}{2}$	Ex emb II T $_6$, T $_5$		562 880	VOFC-L-M32C-MC-G12-1UK4-Ex4me
	3/2-way closed, single solenoid	G $\frac{1}{4}$ and Namur	Ex emb II T $_6$, T $_5$	Internal	562 875	VOFC-L-M32C-M-FG14-1UK4-Ex4me
		G $\frac{1}{4}$ and Namur	Ex ia IIC T $_6$, T $_5$		562 876	VOFC-L-M32C-M-FG14-1K4-Ex3A

Solenoid coils VACC-S13

FESTO

Technical data

-  - Voltage
24 V AC

-  - Temperature range
-20 ... +60 °C



General technical data						
Type			VACC-S13-A1-1	VACC-S13-A1-1U	VACC-S13-A1-2U	VACC-S13-A1-3U
Actuation type			Electrical			
Mounting position			Any			
Duty cycle		[%]	100			
Electrical connection			Plug design to EN 175301-803, type A			
Manual override			None			
Switching position display			None			
Product weight		[g]	210			
Note on materials			Contains PWIS (paint-wetting impairment substances), RoHS-compliant			
Information on solenoid coil materials			Polyamide, polyurethane			
Coil characteristics	DC voltage 24 V	[W]	1.8	1.8	-	-
	AC voltage 24 V	[VA]	-	3	-	-
	DC voltage 110 V	[W]	-	-	1.8	-
	AC voltage 110 V	[VA]	-	-	3	-
	DC voltage 230 V	[W]	-	-	-	1.8
	AC voltage 230 V	[VA]	-	-	-	3

Operating and environmental conditions						
Type			VACC-S13-A1-1	VACC-S13-A1-1U	VACC-S13-A1-2U	VACC-S13-A1-3U
Protection class			IP65			
CE mark (see declaration of conformity)			-			To EU Low Voltage Directive
Permissible voltage fluctuations		[%]	-15 ... +10			
Ambient temperature		[°C]	-20 ... +60			
Corrosion resistance class CRC ¹⁾			4			

1) Corrosion resistance class 4 according to Festo standard 940 070

Components with very heavy corrosion exposure. Components in contact with aggressive media, e.g. in food or chemical industries. These applications must, if necessary, be verified by special tests with the media concerned.

Solenoid coils VACC-S13

Technical data

Dimensions

Download CAD data → www.festo.com

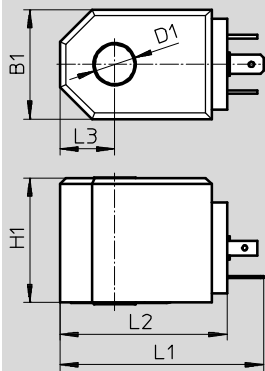

Type	B1	D1	H1	L1	L2	L3
VACC-S13-A1-1 ...	36	13.1	41	67	55	18

Solenoid coils VACC-S13

Technical data – Ignition protection type Ex-me

FESTO

-  Voltage
24 V DC/AC

-  Temperature range
-20 ... +60 °C



General technical data				
Type	VACC-S13-K4-1U-Ex4me	VACC-S13-K4-2U-Ex4me	VACC-S13-K4-3U-Ex4me	VACC-S13-K4-1UF-Ex4me
Actuation type	Electrical			
Mounting position	Any			
Duty cycle [%]	100			
Electrical connection	Terminal box, cable entry thread M20x1.5			
Internal fuse protection	-			Fuse
Manual override	None			
Switching position display	None			
Product weight [g]	330			
Note on materials	Contains PWIS (paint-wetting impairment substances), RoHS-compliant			
Information on solenoid coil materials	PA, PUR			
Coil characteristics	DC voltage 24 V [W]	1.8	-	1.8
	AC voltage 24 V [VA]	1.8	-	1.8
	DC voltage 110 V [W]	-	1.8	-
	AC voltage 110 V [VA]	-	3	-
	DC voltage 230 V [W]	-	-	1.8
	AC voltage 230 V [VA]	-	-	3

Operating and environmental conditions	
Protection class	IP65
Permissible voltage fluctuations [%]	-15 ... +10
ATEX category for gas	II 2G
Explosion ignition protection type for gas	Ex emb IIC T6, T5 Gb
ATEX category for dust	II 2D
Explosion ignition protection type for dust	Ex tb IIIC T80°C, T95°C Db IP65
Designated organisation for the quality inspection	0344
Explosion protection certification outside the EU	EPL Db (BR), EPL Dc (BR), EPL Gb (BR), EPL Gc (BR)
	EPL Db (CN), EPL Dc (CN), EPL Gb (CN), EPL Gc (CN)
	EPL Db (RU), EPL Dc (RU), EPL Gb (RU), EPL Gc (RU)
CE mark (see declaration of conformity)	To EU Explosion Protection Directive (ATEX)
Ambient temperature [°C]	-20 ... +60
Corrosion resistance class CRC ¹⁾	4

1) Corrosion resistance class 4 according to Festo standard 940 070
Components with very heavy corrosion exposure. Components in contact with aggressive media, e.g. in food or chemical industries. These applications must, if necessary, be verified by special tests with the media concerned.

Solenoid coils VACC-S13

Technical data – Ignition protection type Ex-me

Dimensions

Download CAD data → www.festo.com

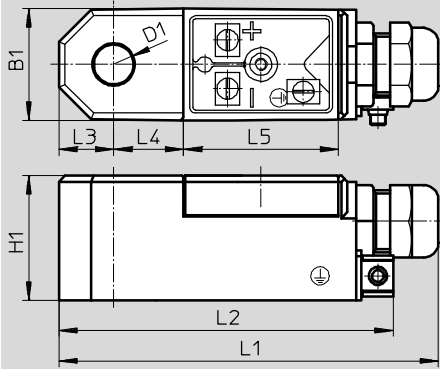

Type	B1	D1	H1	L1	L2	L3	L4	L5
VACC-S13-K4-...-Ex4me	37	13.1	41	125	98	18	23	51

Solenoid coils VACC-S13

Technical data – Ignition protection type Ex-ia

FESTO

-  Voltage
24 V DC/AC

-  Temperature range
-30 ... +60 °C



General technical data	
Type	VACC-S13-K4-Ex3A
Actuation type	Electrical
Mounting position	Any
Duty cycle	[%] 100
Electrical connection	Terminal box, cable entry thread M20x1.5
Manual override	None
Switching position display	None
Product weight	[g] 330
Note on materials	Contains PWIS (paint-wetting impairment substances), RoHS-compliant
Information on solenoid coil materials	PA, PUR
Coil characteristics	[V] 14 ... 32
Max. input power	[W] 1.2
Max. input voltage	[V] 32
Max. input current	[A] 0.2
Required current consumption	[mA] 16

Operating and environmental conditions	
Protection class	IP65
ATEX category for gas	II 2G
Explosion ignition protection type for gas	Ex ia IIC T6, T5
Explosion protection certification outside the EU	EPL Gb (BR), EPL Gb (CN), EPL Gb (RU), EPL Gc (BR), EPL Gc (CN), EPL Gc (RU)
CE mark (see declaration of conformity)	To EU Explosion Protection Directive (ATEX)
Ambient temperature	[°C] -30 ... +60
Corrosion resistance class CRC ¹⁾	4

1) Corrosion resistance class 4 according to Festo standard 940 070
Components with very heavy corrosion exposure. Components in contact with aggressive media, e.g. in food or chemical industries. These applications must, if necessary, be verified by special tests with the media concerned.

Solenoid coils VACC-S13

Technical data – Ignition protection type Ex-ia

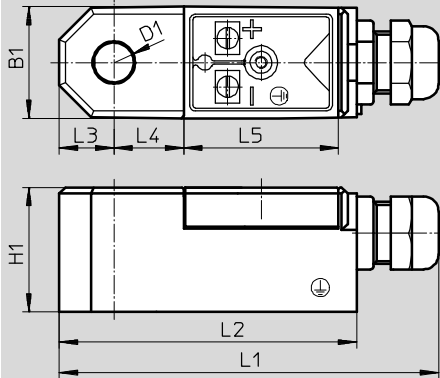

Dimensions

Download CAD data → www.festo.com



Type	B1	D1	H1	L1	L2	L3	L4	L5
VACC-S13-K4-...-Ex3A	37	13.1	41	125	98	18	23	51

Ordering data

		Part No.	Type
Standard			
		562 889	VACC-S13-A1-1
		562 890	VACC-S13-A1-1U
		562 891	VACC-S13-A1-2U
		562 892	VACC-S13-A1-3U
Ex-me coil			
		562 893	VACC-S13-K4-1U-Ex4me
		562 894	VACC-S13-K4-2U-Ex4me
		562 895	VACC-S13-K4-3U-Ex4me
		570 784	VACC-S13-K4-1UF-Ex4me
Ex-ia coil			
		562 896	VACC-S13-K4- -Ex3A

Solenoid valves

Accessories



Flow control plate

Material:
Manifold rail:
Wrought aluminium alloy
Contains paint-wetting impairment
substances, RoHS-compliant

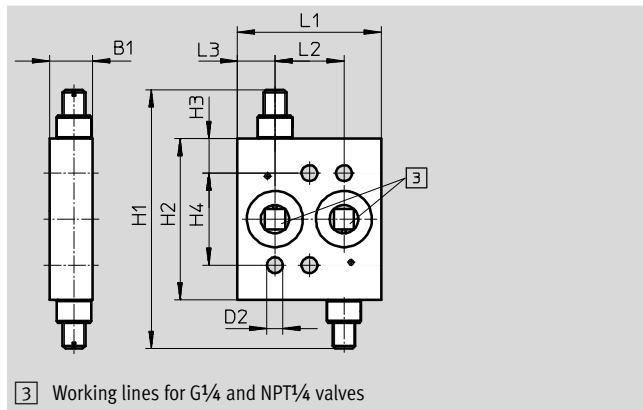
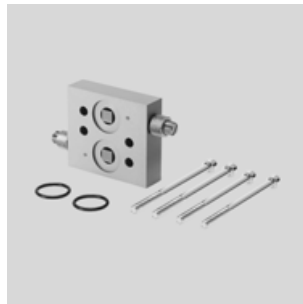

Dimensions [mm] and ordering data											
B1	D2	H1	H2	H3	H4	L1	L2	L3	CRC ¹⁾	Part No.	Type
15	5.5	90	56	12	32	50	24	13	3	563 395	VABF-S7-F1B1P2-F

1) Corrosion resistance class 3 according to Festo standard 940 070
Components subject to high corrosion stress. External visible parts in direct contact with industrial atmospheres or media such as solvents and cleaning agents, with a predominantly functional requirement for the surface.

Flow control plate

Material:
Manifold rail:
Wrought aluminium alloy
Contains paint-wetting impairment
substances, RoHS-compliant

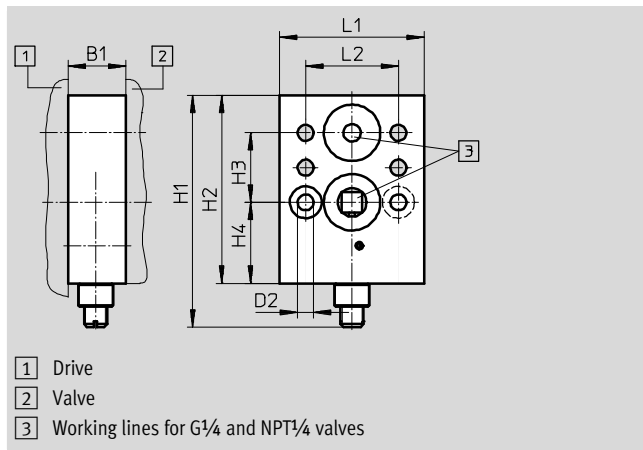

Dimensions [mm] and ordering data											
B1	D2	H1	H2	H3	H4	L1	L2	CRC ¹⁾	Part No.	Type	
20	5.5	80	65	24	28	50	32	3	563 401	VABF-S7-F1B5P1-F	

1) Corrosion resistance class 3 according to Festo standard 940 070
Components subject to high corrosion stress. External visible parts in direct contact with industrial atmospheres or media such as solvents and cleaning agents, with a predominantly functional requirement for the surface.

Solenoid valves

Accessories



Mounting plate

Material:
Wrought aluminium alloy
Contains paint-wetting impairment substances, RoHS-compliant

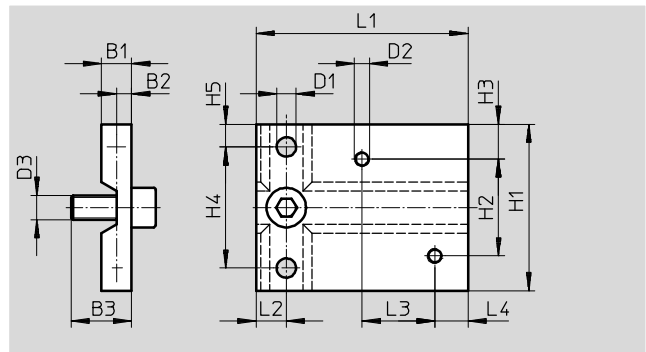

Dimensions [mm] and ordering data																Part No.	Type
B1	B2	B3	D1	D2	D3	H1	H2	H3	H4	H5	L1	L2	L3	L4	CRC ¹⁾		
10	5	20	6.4	M5	M8	55	32	11.5	40	7.5	70	10	24	11	3	563 399	VAME-S7-P

1) Corrosion resistance class 3 according to Festo standard 940 070
Components subject to high corrosion stress. External visible parts in direct contact with industrial atmospheres or media such as solvents and cleaning agents, with a predominantly functional requirement for the surface.

Connection plate kit

Material:
Wrought aluminium alloy
Contains paint-wetting impairment substances, RoHS-compliant

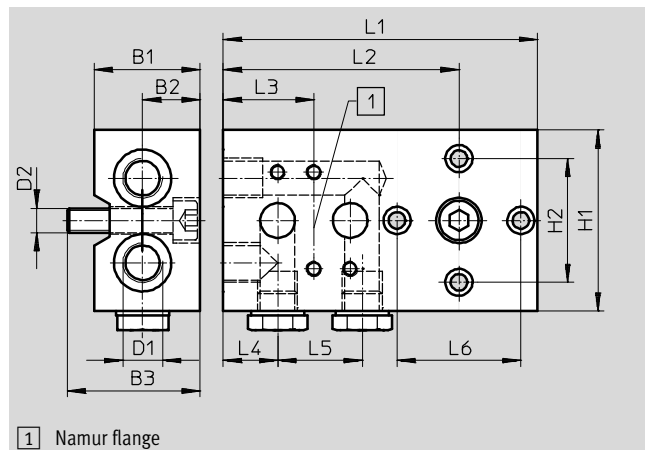

Dimensions [mm] and ordering data																Part No.	Type
B1	B2	B3	D1	D2	H1	H2	L1	L2	L3	L4	L5	L6	CRC ¹⁾				
35	19	44	G ¹ / ₄	M8	60	41	104	78	30	18	28	41	3	563 396	VABS-S7-S-G14		

1) Corrosion resistance class 3 according to Festo standard 940 070
Components subject to high corrosion stress. External visible parts in direct contact with industrial atmospheres or media such as solvents and cleaning agents, with a predominantly functional requirement for the surface.

Solenoid valves

Accessories

FESTO

Mounting bracket

Material:
Wrought aluminium alloy
Contains paint-wetting impairment substances, RoHS-compliant

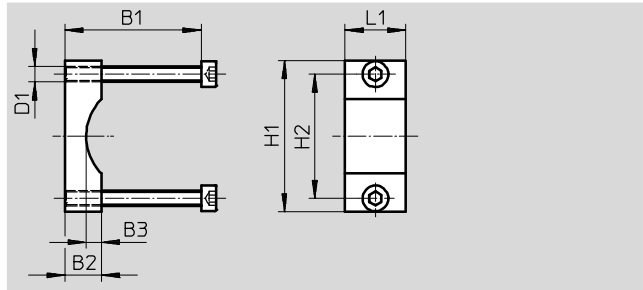

Dimensions [mm] and ordering data									
B1	B2	B3	D1	H1	H2	L1	CRC ¹⁾	Part No.	Type
45/65	12	5	M5	50	41	20	3	563 403	VAME-S7-Y

1) Corrosion resistance class 3 according to Festo standard 940 070
Components subject to high corrosion stress. External visible parts in direct contact with industrial atmospheres or media such as solvents and cleaning agents, with a predominantly functional requirement for the surface.

Adapter with filter

Note on materials:
Contains paint-wetting impairment substances, RoHS-compliant

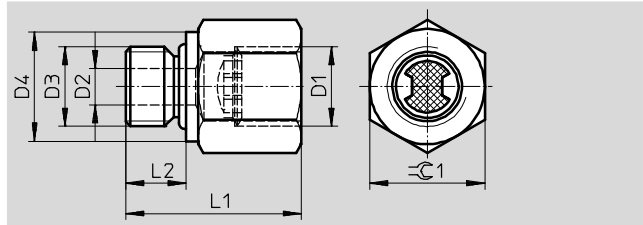

Dimensions [mm] and ordering data									
D1	D2	D3	D4	L1	L2	≈C1	CRC ¹⁾	Part No.	Type
NPT $\frac{1}{4}$	6	G $\frac{1}{4}$	18	29	10	19	1	563 397	NPFV-AF-G14-N14-MF
G $\frac{1}{4}$	6	G $\frac{1}{4}$	18	29	10	19	1	563 398	NPFV-AF-G14-G14-MF

1) Corrosion resistance class 1 according to Festo standard 940 070
Components subject to low corrosion stress. Transport and storage protection. Parts that do not have primarily decorative surface requirements, e.g. in internal areas that are not visible or behind covers.

Solenoid valves

Accessories

Exhaust protection

Material:
Ethylene propylene rubber
Contains paint-wetting impairment substances, RoHS-compliant

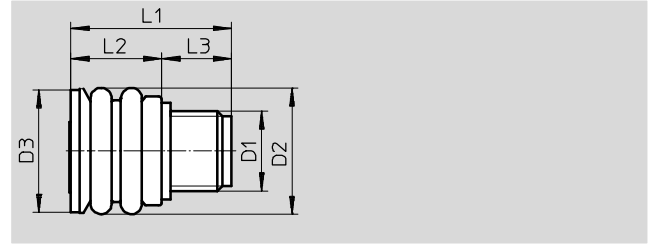

Dimensions [mm] and ordering data								Part No.	Type
D1	D2	D3	L1	L2	L3	CRC ¹⁾			
G1/4	21	20.5	26.5	15	11.5	3	563 400	VABD-D3-SN-G14	

1) Corrosion resistance class 3 according to Festo standard 940 070
Components subject to high corrosion stress. External visible parts in direct contact with industrial atmospheres or media such as solvents and cleaning agents, with a predominantly functional requirement for the surface.

Ordering data		Part No.	Type
Cable		Technical data → Internet: kmc	
		30 931	KMC-1-24 DC-2,5-LED
		30 932	KMC-1-230 AC-2,5
		30 933	KMC-1-24 DC-5-LED
		30 934	KMC-1-230 AC-5
		30 935	KMC-1-24-10-LED
Plug socket for screw terminal connection		Technical data → Internet: mssd	
		34 583	MSSD-C

Product Range and Company Overview

A Complete Suite and Company Overview

Our experienced engineers provide complete support at every stage of your development process, including: conceptualization, analysis, engineering, design, assembly, documentation, validation, and production.



Custom Automation Components
Complete custom engineered solutions

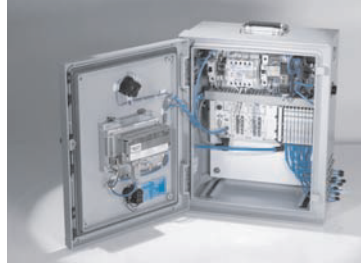

Custom Control Cabinets
Comprehensive engineering support and on-site services



Complete Systems
Shipment, stocking and storage services

The Broadest Range of Automation Components

With a comprehensive line of more than 30,000 automation components, Festo is capable of solving the most complex automation requirements.



Electromechanical
Electromechanical actuators, motors, controllers & drivers



Pneumatics
Pneumatic linear and rotary actuators, valves, and air supply



PLCs and I/O Devices
PLC's, operator interfaces, sensors and I/O devices

Supporting Advanced Automation... As No One Else Can!

Festo is a leading global manufacturer of pneumatic and electromechanical systems, components and controls for industrial automation, with more than 16,000 employees in 60 national headquarters serving more than 180 countries. For more than 80 years, Festo has continuously elevated the state of manufacturing with innovations and optimized motion control solutions that deliver higher performing, more profitable automated manufacturing and processing equipment. Our dedication to the advancement of automation extends beyond technology to the education and development of current and future automation and robotics designers with simulation tools, teaching programs, and on-site services.

Quality Assurance, ISO 9001 and ISO 14001 Certifications

Festo Corporation is committed to supply all Festo products and services that will meet or exceed our customers' requirements in product quality, delivery, customer service and satisfaction.

To meet this commitment, we strive to ensure a consistent, integrated, and systematic approach to management that will meet or exceed the requirements of the ISO 9001 standard for Quality Management and the ISO 14001 standard for Environmental Management.



© Copyright 2013, Festo Corporation. While every effort is made to ensure that all dimensions and specifications are correct, Festo cannot guarantee that publications are completely free of any error, in particular typing or printing errors. Accordingly, Festo cannot be held responsible for the same. For Liability and Warranty conditions, refer to our "Terms and Conditions of Sale", available from your local Festo office. All rights reserved. No part of this publication may be reproduced, distributed, or transmitted in any form or by any means, electronic, mechanical, photocopying or otherwise, without the prior written permission of Festo. All technical data subject to change according to technical update.



Printed on recycled paper at New Horizon Graphic, Inc., FSC certified as an environmental friendly printing plant.

Festo North America

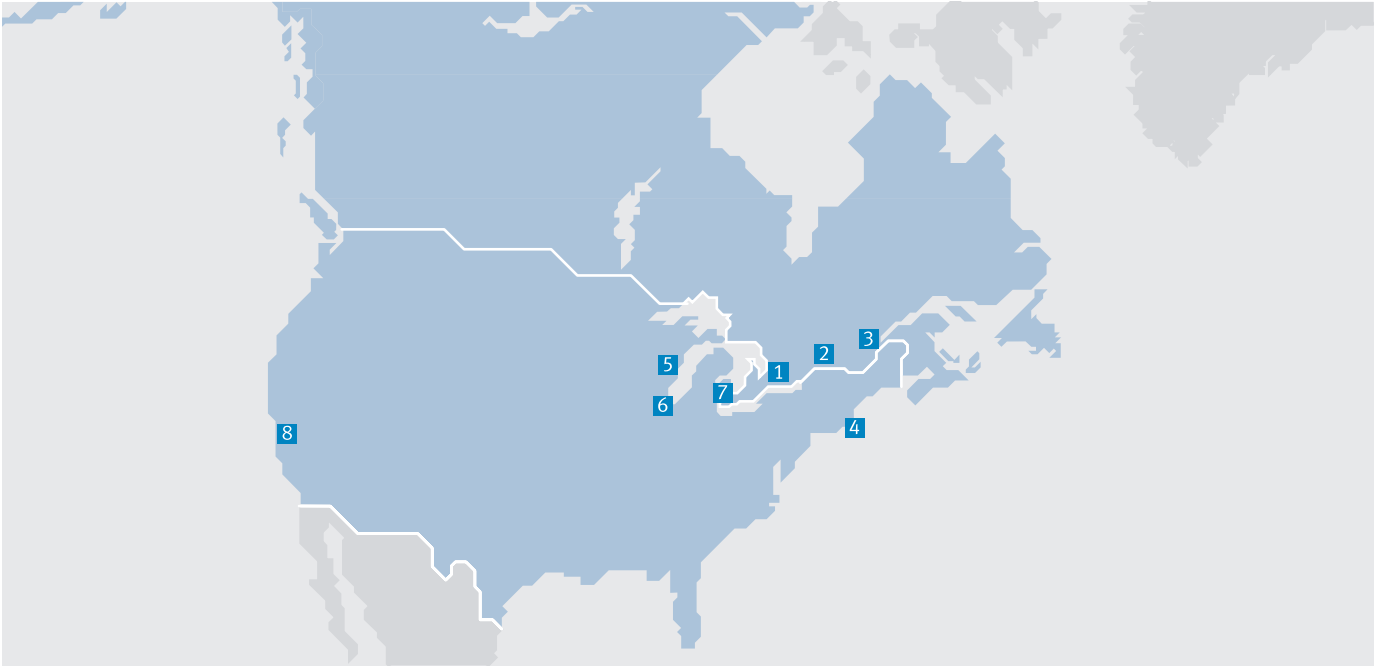

**1 Festo Canada
Headquarters
Festo Inc.**
5300 Explorer Drive
Mississauga, ON
L4W 5G4

2 Montréal
5600, Trans-Canada
Pointe-Claire, QC
H9R 1B6

3 Québec City
2930, rue Watt#117
Québec, QC
G1X 4G3



**4 Festo United States
Headquarters
Festo Corporation**
395 Moreland Road
Hauppauge, NY
11788

5 Appleton
North 922 Tower View Drive, Suite N
Greenville, WI
54942

7 Detroit
1441 West Long Lake Road
Troy, MI
48098

6 Chicago
85 W Algonquin - Suite 340
Arlington Heights, IL
60005

8 Silicon Valley
4935 Southfront Road, Suite F
Livermore, CA
94550

Festo Regional Contact Center

Canadian Customers

Commercial Support:
Tel: 1 877 GO FESTO (1 877 463 3786)
Fax: 1 877 FX FESTO (1 877 393 3786)
Email: festo.canada@ca.festo.com

Technical Support:
Tel: 1 866 GO FESTO (1 866 463 3786)
Fax: 1 877 FX FESTO (1 877 393 3786)
Email: technical.support@ca.festo.com

USA Customers

Commercial Support:
Tel: 1 800 99 FESTO (1 800 993 3786)
Fax: 1 800 96 FESTO (1 800 963 3786)
Email: customer.service@us.festo.com

Technical Support:
Tel: 1 866 GO FESTO (1 866 463 3786)
Fax: 1 800 96 FESTO (1 800 963 3786)
Email: product.support@us.festo.com