

Valves, mechanically actuated

FESTO



Valves, mechanically actuated

Key features

FESTO

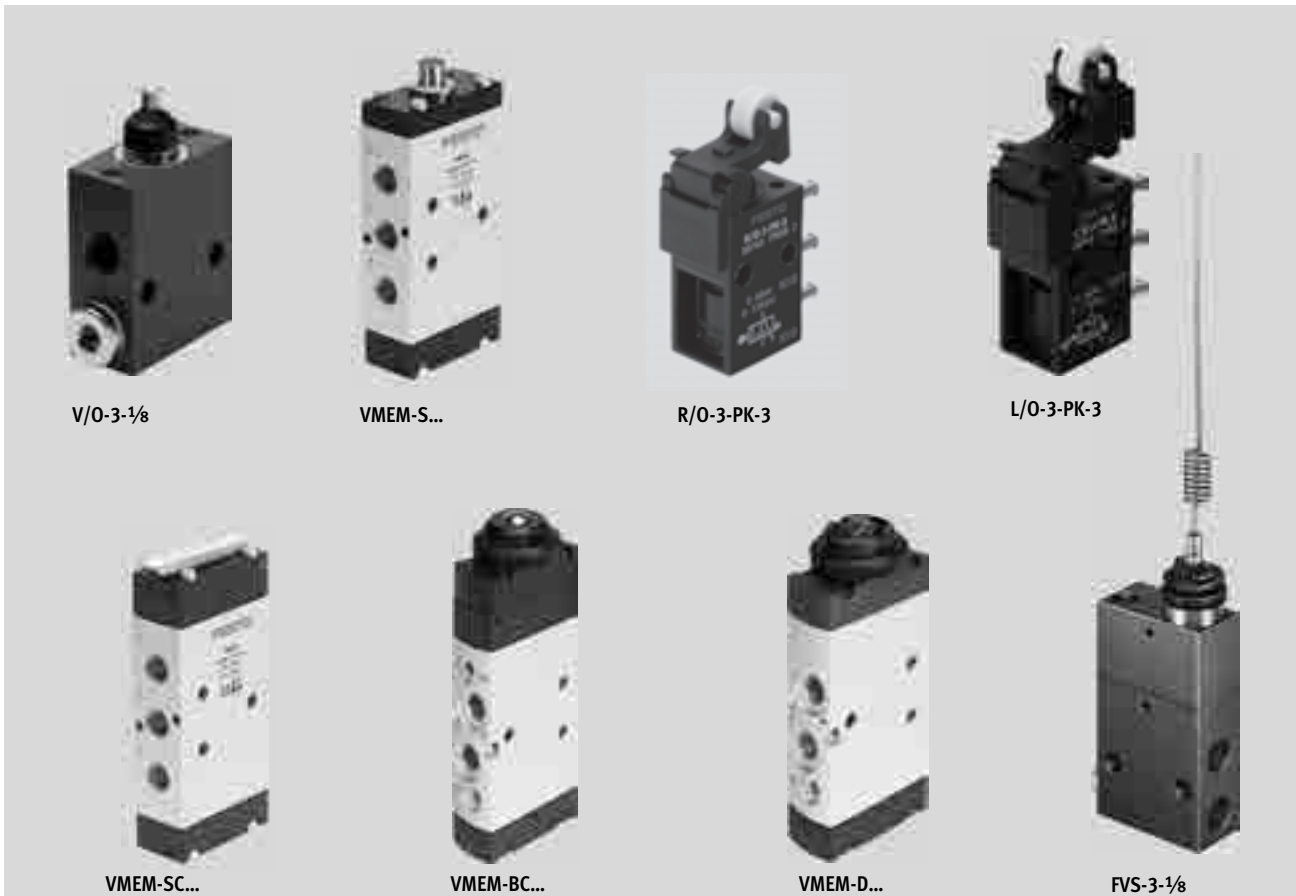

Innovative

- Small and compact for a wide range of pneumatic applications
- Large selection of valve functions; 3/2-way, 4/2-way and 5/2-way functions
- With flow rates of up to 1,000 l/min, valves VMEM offer outstanding pneumatic performance for a great variety of applications
- Low weight
- Minimal actuating forces

Versatile

- Flexibility of the pneumatic working ports provides a practical solution to different requirements
- Round silencer for ducted exhaust air
- Suitable for vacuum in some cases
- Reverse operation possible in some cases
- Actuation: direct and piloted
- Pressure range from vacuum to 10 bar possible
- Version:
 - Stem actuated valve
 - Swivel lever valve
 - Roller lever valve, toggle lever valve
 - Whisker valve
 - Roller actuated valve
 - Ball actuated valve

Reliable

- Durable thanks to proven piston spool and piston poppet valves
- Sturdy thanks to metal or plastic housing and connecting thread or connector

Easy to mount

- Front panel mounting or mounting on bracket

Valves, mechanically actuated

Key features

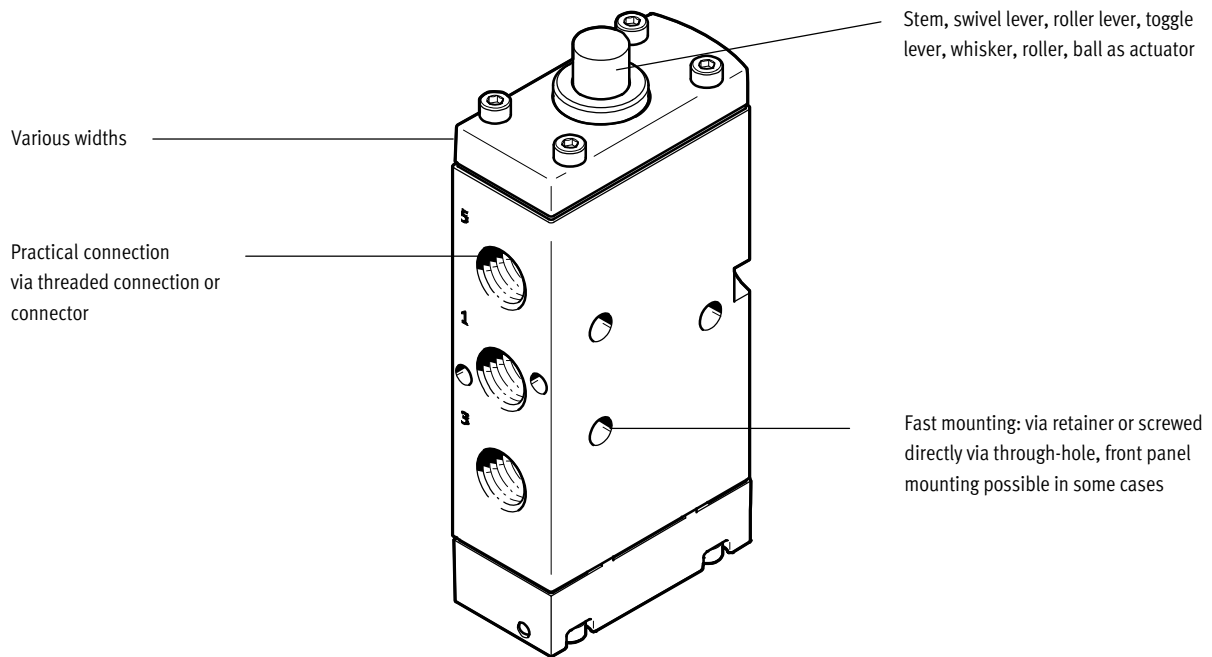

Equipment options

3/2-way valve, monostable

- Normally open/closed
- Mechanical spring
- Vacuum operation possible
- Directly actuated and pneumatically piloted
- Ducted exhaust air

4/2-way valve, monostable

- Mechanical spring
- Pneumatically piloted
- Ducted exhaust air

5/2-way valve, monostable

- Pneumatic spring/mechanical spring
- Vacuum operation possible
- Reverse operation in some cases
- Pneumatically piloted
- Ducted exhaust air

Valve selection

→ Internet: www.festo.com

You order mechanically and manually operated valves using the order code:

Ordering system for valves
 → Internet: mechanically and manually operated directional control valves

Valves, mechanically actuated

Peripherals overview

Valves, mechanically actuated

5/2-way stem actuated valve VMEM-S

3/2-way roller lever valve R

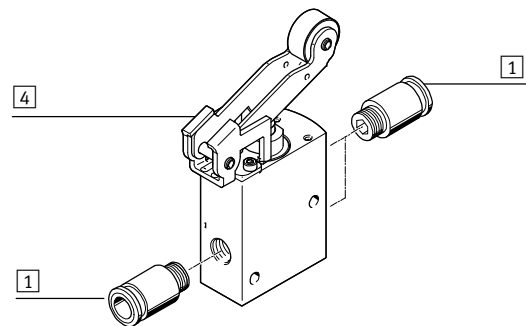
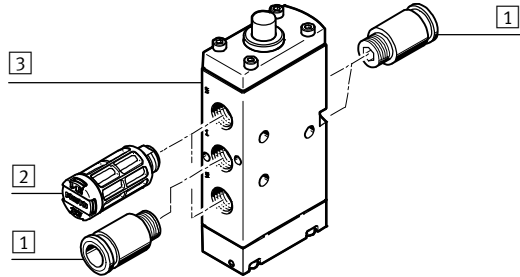

	Brief description	→ Page/Internet	
1	Fitting	For supply air/exhaust ports (1, 3, 5) and working ports (2, 4)	47
2	Silencer	For exhaust ports (3, 5)	47
3	Stem actuated valve	VMEM-S	11
4	Roller lever valve	R	30

3/2-way roller lever valve with idle return L

3/2-way toggle lever valve LS

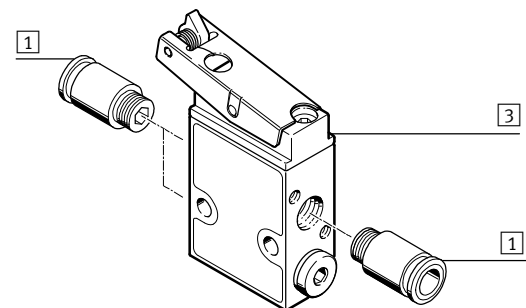
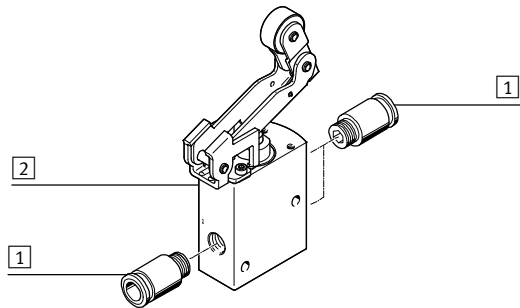

	Brief description	→ Page/Internet	
1	Fitting	For supply air/exhaust ports (1, 3, 5) and working ports (2, 4)	47
2	Roller lever valve with idle return	L	30
3	Toggle lever valve	LS	30

5/2-way roller actuated valve VMEM-D

3/2-way ball actuated valve VMEM-B

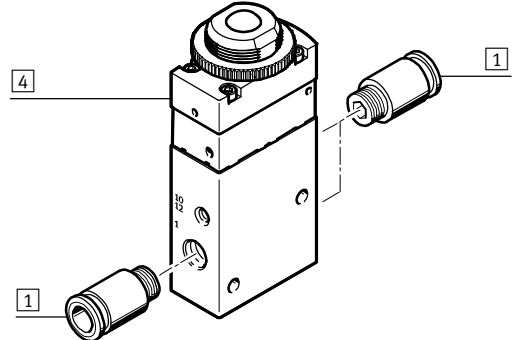
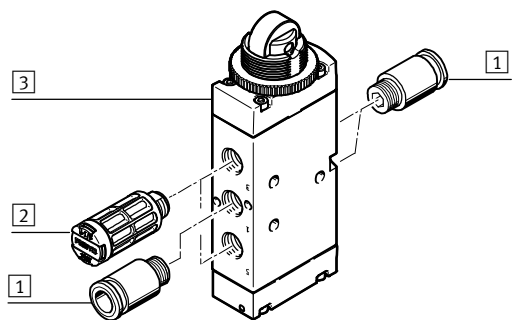

	Brief description	→ Page/Internet	
1	Fitting	For supply air/exhaust ports (1, 3, 5) and working ports (2, 4)	47
2	Silencer	For exhaust ports (3, 5)	47
3	Roller actuated valve	VMEM-D	37
4	Ball actuated valve	VMEM-B	44

Valves, mechanically actuated

Key features – Pneumatic components

Mechanically actuated valves



Mechanically actuated valves are often used as "signal valves" and feed back a pneumatic signal to the controller. This feedback, e.g. "End position reached", is realised via a stem actuated valve or roller actuated

valve. This is a simple application, but it is an extremely popular solution for smaller machines and conveying systems, e.g. for controlling simple clamping and locking operations in

semi-automated assembly and production. The modern design with metal housing combines sturdiness and functionality.

Advantages of mechanically actuated valves:

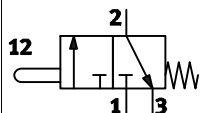
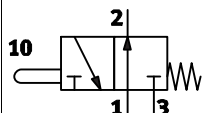
- No electronic controller required
- No programming effort required
- Easy to adjust and connect
- Control and measurement via sensors

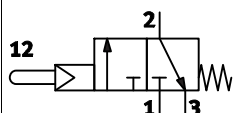
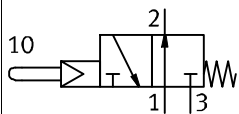
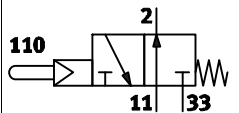
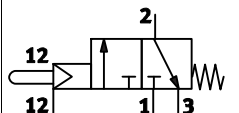
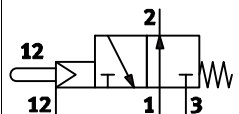
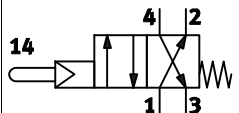
Valve functions		
Circuit symbol	Type	Description
Stem actuated valve		
	VMEM-ST-M32C-M V-3-M5 V-3-1/4-B V/O-3-PK-3	3/2-way valve, monostable • Normally closed • Mechanical spring return • Suitable for vacuum (not V/O-3-PK-3)
	VMEM-ST-M32U-M VO-3-1/4-B	3/2-way valve, monostable • Normally open • Mechanical spring return • Suitable for vacuum
	V/O-3-1/8	3/2-way valve, monostable • Normally open/closed • Mechanical spring return • Suitable for vacuum
	VMEM-STC-M32C-M VS-3-1/8	3/2-way valve, monostable • Normally closed • Pneumatically piloted, internal pilot air • Mechanical spring return
	VMEM-STC-M32U-M	3/2-way valve, monostable • Normally open • Pneumatically piloted, internal pilot air • Mechanical spring return
	VOS-3-1/8	3/2-way valve, monostable • Normally open • Pneumatically piloted, internal pilot air • Mechanical spring return
	VMEM-STCZ-M32C-M	3/2-way valve, monostable • Normally closed • Pneumatically piloted, external pilot air • Mechanical spring return
	VMEM-STCZ-M32U-M	3/2-way valve, monostable • Normally open • Pneumatically piloted, external pilot air • Mechanical spring return
	VS-4-1/8	4/2-way valve, monostable • Pneumatically piloted, internal pilot air • Mechanical spring return

Valves, mechanically actuated

Key features – Pneumatic components

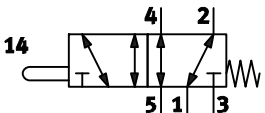
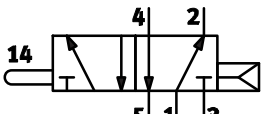
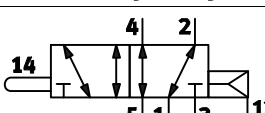
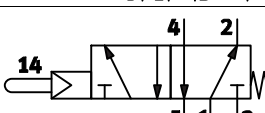
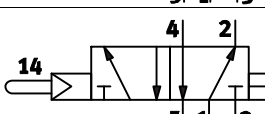
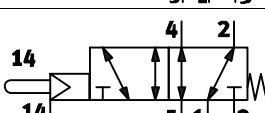
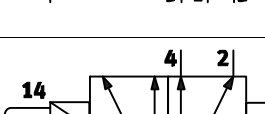
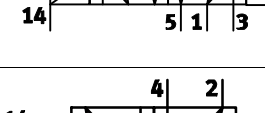
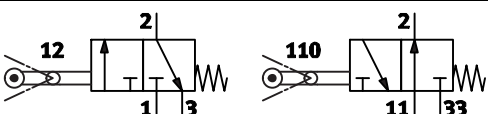
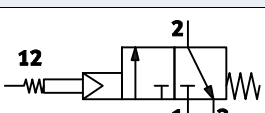
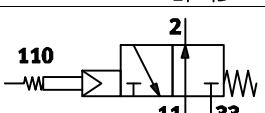
Valve functions		
Circuit symbol	Type	Description
Stem actuated valve		
	VMEM-S-M52-M	5/2-way valve, monostable <ul style="list-style-type: none"> Mechanical spring return Suitable for vacuum Reverse operation possible
	VMEM-S-M52-A	5/2-way valve, monostable <ul style="list-style-type: none"> (Internal) pneumatic spring return
	VMEM-S-M52-E	5/2-way valve, monostable <ul style="list-style-type: none"> (External) pneumatic spring return Suitable for vacuum Reverse operation possible
	VMEM-SC-M52-M	5/2-way valve, monostable <ul style="list-style-type: none"> Pneumatically piloted, internal pilot air Mechanical spring return
	VMEM-SC-M52-A	5/2-way valve, monostable <ul style="list-style-type: none"> Pneumatically piloted, internal pilot air (Internal) pneumatic spring return
	VMEM-SCZ-M52-M	5/2-way valve, monostable <ul style="list-style-type: none"> Pneumatically piloted, external pilot air Mechanical spring return Suitable for vacuum Reverse operation possible
	VMEM-SCZ-M52-E	5/2-way valve, monostable <ul style="list-style-type: none"> Pneumatically piloted, external pilot air (External) pneumatic spring return Suitable for vacuum Reverse operation possible
	V-5-1/4-B	5/2-way valve, monostable <ul style="list-style-type: none"> Normally open/closed Mechanical spring return Suitable for vacuum
Swivel lever valve		
	RW/O-3-1/8	3/2-way valve, monostable <ul style="list-style-type: none"> Normally open/closed Mechanical spring return Suitable for vacuum
Whisker valve		
	FVS-3-1/8	3/2-way valve, monostable <ul style="list-style-type: none"> Normally closed Mechanical spring return Pneumatically piloted, internal pilot air
	FVS0-3-1/8	3/2-way valve, monostable <ul style="list-style-type: none"> Normally open Mechanical spring return Pneumatically piloted, internal pilot air

Valves, mechanically actuated

Key features – Pneumatic components

Valve functions – Circuit symbol		
Circuit symbol	Type	Description
Roller lever valve with idle return		
	L/O-3-PK-3	3/2-way valve, monostable <ul style="list-style-type: none"> • Normally open/closed • Mechanical spring return
	L-3-M5 L-3-1/4-B	3/2-way valve, monostable <ul style="list-style-type: none"> • Normally closed • Mechanical spring return • Suitable for vacuum
	L-5-1/4-B	5/2-way valve, monostable <ul style="list-style-type: none"> • Mechanical spring return • Suitable for vacuum
Toggle lever valve		
	LS-3-1/8	3/2-way valve, monostable <ul style="list-style-type: none"> • Normally closed • Mechanical spring return • Pneumatically piloted, internal pilot air
	LOS-3-1/8	3/2-way valve, monostable <ul style="list-style-type: none"> • Normally open • Mechanical spring return • Pneumatically piloted, internal pilot air
	LO-3-1/4-B	3/2-way valve, monostable <ul style="list-style-type: none"> • Normally open • Mechanical spring return • Suitable for vacuum
	LS-4-1/8	4/2-way valve, monostable <ul style="list-style-type: none"> • Mechanical spring return • Pneumatically piloted, internal pilot air

Valves, mechanically actuated

Key features – Pneumatic components

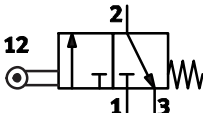
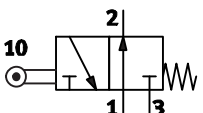
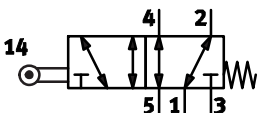
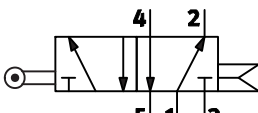
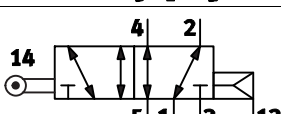
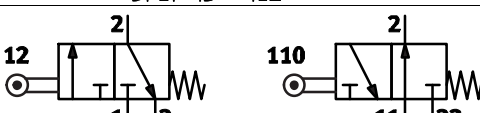
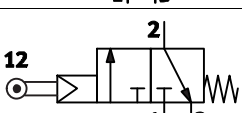
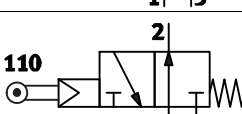
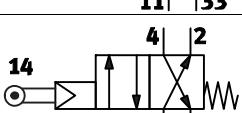
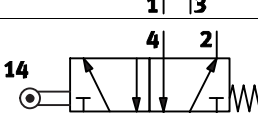
Valve functions – Circuit symbol		
Circuit symbol	Type	Description
Roller lever, roller actuated valve		
	VMEM-DT-M32C-M R-3-M5 R-3-1/4-B	3/2-way valve, monostable <ul style="list-style-type: none"> • Normally closed • Mechanical spring return • Suitable for vacuum
	VMEM-DT-M32U-M RO-3-1/4-B	3/2-way valve, monostable <ul style="list-style-type: none"> • Normally open • Mechanical spring return • Suitable for vacuum
	VMEM-D-M52-M	5/2-way valve, monostable <ul style="list-style-type: none"> • Mechanical spring return • Suitable for vacuum • Reverse operation possible
	VMEM-D-M52-A	5/2-way valve, monostable <ul style="list-style-type: none"> • (Internal) pneumatic spring return
	VMEM-D-M52-E	5/2-way valve, monostable <ul style="list-style-type: none"> • (External) pneumatic spring return • Suitable for vacuum • Reverse operation possible
	R/O-3-PK-3	3/2-way valve, monostable <ul style="list-style-type: none"> • Normally open/closed • Mechanical spring return
	RS-3-1/8	3/2-way valve, monostable <ul style="list-style-type: none"> • Normally closed • Mechanical spring return • Pneumatically piloted, internal pilot air
	ROS-3-1/8	3/2-way valve, monostable <ul style="list-style-type: none"> • Normally open • Mechanical spring return • Pneumatically piloted, internal pilot air
	RS-4-1/8	4/2-way valve, monostable <ul style="list-style-type: none"> • Mechanical spring return • Pneumatically piloted, internal pilot air
	R-5-1/4-B	5/2-way valve, monostable <ul style="list-style-type: none"> • Mechanical spring return • Suitable for vacuum

Valves, mechanically actuated

Key features – Pneumatic components

Valve functions		
Circuit symbol	Type	Description
Ball actuated valve		
	VMEM-BTC-M32C-M	3/2-way valve, monostable <ul style="list-style-type: none"> • Normally closed • Mechanical spring return • Pneumatically piloted, internal pilot air
	VMEM-BTC-M32U-M	3/2-way valve, monostable <ul style="list-style-type: none"> • Normally open • Mechanical spring return • Pneumatically piloted, internal pilot air
	VMEM-BTCZ-M32C-M	3/2-way valve, monostable <ul style="list-style-type: none"> • Normally closed • Mechanical spring return • Pneumatically piloted, external pilot air
	VMEM-BTCZ-M32U-M	3/2-way valve, monostable <ul style="list-style-type: none"> • Normally open • Mechanical spring return • Pneumatically piloted, external pilot air
	VMEM-BC-M52-M	5/2-way valve, monostable <ul style="list-style-type: none"> • Mechanical spring return • Pneumatically piloted, internal pilot air
	VMEM-BC-M52-A	5/2-way valve, monostable <ul style="list-style-type: none"> • Pneumatic spring return • Pneumatically piloted, internal pilot air
	VMEM-BCZ-M52-M	5/2-way valve, monostable <ul style="list-style-type: none"> • Mechanical spring return • Pneumatically piloted, external pilot air • Suitable for vacuum • Reverse operation possible
	VMEM-BCZ-M52-E	5/2-way valve, monostable <ul style="list-style-type: none"> • Pneumatic spring return • Pneumatically piloted, external pilot air • Suitable for vacuum • Reverse operation possible

- - Note

A filter must be installed upstream of valves operated in vacuum mode. This prevents any foreign matter in the intake air getting into the valve (e.g. when operating a suction cup).

Valves, mechanically actuated

Type codes

FESTO

VMEM - STCZ - M32C - M - G14

Valve series	
VMEM	Mechanically actuated valves

Version

Actuation	
S	Stem actuated valve
D	Valve with roller actuation
B	Valve with ball actuation
Design principle	
-	Piston spool
T	Disk seat
Actuation method	
-	Directly actuated
C	Pneumatically piloted
Pilot air supply	
-	Internal
Z	External
Switching function	
-	Monostable valve
A	Active (spring)
X	Passive (air)

Valve function

M32C	3/2-way valve, monostable, normally closed
M32U	3/2-way valve, monostable, normally open
M52	5/2-way valve, monostable

Reset method

-	None
A	Pneumatic spring, internal
E	Pneumatic spring, external
M	Mechanical spring

Pneumatic connection

G14	Fitting G1/4
G18	Fitting G1/8

Stem actuated valves

Technical data – Stem actuated valve, standard nominal flow rate 80 ... 140 l/min

 Flow rate
80 ... 1,000 l/min

Mounting via through-holes

 Pressure
-0.95 ... +10 bar

 Temperature range
-10 ... +60 °C



General technical data					
Type	V-3-M5	V/O-3-PK-3	V ... -3-1/8	VS-4-1/8	V/O-3-1/8 RW/O-3-1/8
Standard nominal flow rate [l/min] 1 → 2	80		120	120	140
Valve function	3/2-way valve		3/2-way valve	4/2-way valve	3/2-way valve
Design	Disk seat valve, directly actuated		Disk seat valve, piloted	Disk seat valve, piloted	Disk seat valve, directly actuated
Pneumatic connection	M5	PK-3 ¹⁾	G1/8	G1/8	G1/8
Nominal size [mm]	2.0	2.5	3.5	3.5	3.5
Weight [g]	25	20	110	220	90 ²⁾ 150
Actuating force [N]	23.0	17.0	3.1	3.1	28.0
• at 6 bar					
• with normally closed position	[N]	–	17.0	–	–
• with normally open position	[N]	–	24.0	–	–

1) PK-3=Barbed fitting for plastic tubing with 3 mm nominal diameter
2) Value 90 with stem actuated valve, value 150 with swivel lever valve

Materials					
Type	V-3-M5	V/O-3-PK-3	V ... -3-1/8	VS-4-1/8	V/O-3-1/8 RW/O-3-1/8
Seal	NBR				
Housing	Die-cast zinc	POM	Anodised aluminium		

Operating and environmental conditions					
Type	V-3-M5	V/O-3-PK-3	V ... -3-1/8	VS-4-1/8	V/O-3-1/8 RW/O-3-1/8
Operating medium	Compressed air to ISO 8573-1:2010 [7:--:-]				Compressed air – oil mist lubrication
Note on operating/pilot medium	Lubricated operation possible (required during subsequent operation)				
Operating pressure range [bar]	-0.95 ... 8	0 ... 8	3.5 ... 8		-0.95 ... 8
Temperature of medium [°C]	-10 ... +60				
Ambient temperature [°C]	-10 ... +60	–			

Technical data – Actuator attachment for swivel lever valve RW/O-3-1/8			
Swivel lever, type	ASK-02 (short)	ASL-02 (long)	ASS-02 (rod)
Actuating force [N] Max.	7	Dependent on starting height	
Weight [g]	30	35	30

Materials – Swivel lever	
Swivel lever	Aluminium, steel

Stem actuated valves

Technical data – Stem actuated valve, standard nominal flow rate 500 l/min

General technical data					
Type	VMEM-ST-M32	VMEM-STC ... -M32	VMEM-S-M52	VMEM-SC-M52	VMEM-SCZ-M52
Standard nominal flow rate [l/min] 1 → 2	500				
Valve function	3/2-way valve		5/2-way valve		
Reset method	Mechanical spring		Mechanical or pneumatic spring		
Design	Disk seat valve, directly actuated	Disk seat valve, piloted	Piston spool valve, directly actuated	Piston spool valve, piloted	Piston spool valve, piloted
Pneumatic connection	G $\frac{1}{8}$	G $\frac{1}{8}$	G $\frac{1}{8}$	G $\frac{1}{8}$	G $\frac{1}{8}$
Pilot air supply	–	Internal or external	–	Internal	External
Nominal size [mm]	4.0	4.0	4.0	4.0	4.0
Weight [g]	130	152	148	170	170
Actuating force [N]	80 ¹⁾ 130	15.5	28 ²⁾ 39	15.5	15.5

- 1) Value 80 with normally closed valve, value 130 with normally open valve
 2) Value 28 with mechanical spring reset method, value 39 with pneumatic spring reset method

Materials					
Type	VMEM-ST-M32	VMEM-STC ... -M32	VMEM-S-M52	VMEM-SC-M52	VMEM-SCZ-M52
Cover	–	POM	PA		
Seal	NBR				
Housing	Anodised wrought aluminium alloy				
Note on materials	RoHS-compliant				

Operating and environmental conditions					
Type	VMEM-ST-M32	VMEM-STC ... -M32	VMEM-S-M52	VMEM-SC-M52	VMEM-SCZ-M52
Operating medium	Compressed air to ISO 8573-1:2010 [7:-:-]				
Note on operating/pilot medium	Lubricated operation possible (required during subsequent operation)				
Operating pressure range [bar]					
N/C valves	–0.95 ... 8	3.5 ... 8	–	–	–
N/O valves	–0.95 ... 8	4.5 ... 8	–0.95 ... 10 ¹⁾	2.5 ... 10 ²⁾	2.5 ... 10
Temperature of medium [°C]	–10 ... +60				
Ambient temperature [°C]	–10 ... +60				

- 1) Suitable for vacuum, mechanical spring or external pneumatic spring reset method (in the type codes Reset method M: Mechanical spring or E: External pneumatic spring)
 2) Not suitable for vacuum, internal pneumatic spring reset method (in the type codes Reset method A: Internal pneumatic spring)

Stem actuated valves

Technical data – Stem actuated valve, standard nominal flow rate 550 ... 600 l/min

General technical data			
Type	V-5-1/4-B	VO-3-1/4-B	V-3-1/4-B
Standard nominal flow rate [l/min] 1 → 2	550	600	
Valve function	5/2-way valve	3/2-way valve	
Design	Disk seat valve, directly actuated	Disk seat valve, directly actuated	Disk seat valve, directly actuated
Pneumatic connection	G1/4	G1/4	G1/4
Nominal size [mm]	7.0	7.0	7.0
Weight [g]	240	130	130
Actuating force [N]	198.0	93.0	71.0

Materials	
Seal	NBR
Housing	Die-cast aluminium

Operating and environmental conditions	
Operating medium	Compressed air to ISO 8573-1:2010 [7:-:-]
Note on operating/pilot medium	Lubricated operation possible (required during subsequent operation)
Operating pressure range [bar]	-0.95 ... 10
Temperature of medium [°C]	-10 ... +60
Ambient temperature [°C]	-10 ... +60

Stem actuated valves

Technical data – Stem actuated valve, standard nominal flow rate 1,000 l/min

General technical data				
Type	VMEM-ST	VMEM-S	VMEM-SC	VMEM-SCZ
Standard nominal flow rate [l/min] 1 → 2	1,000			
Valve function	3/2-way valve	5/2-way valve		
Reset method	Mechanical spring	Mechanical or pneumatic spring		
Design	Disk seat valve, directly actuated	Piston spool valve, directly actuated	Piston spool valve, directly actuated	Piston spool valve, directly actuated
Pneumatic connection	G $\frac{1}{4}$	G $\frac{1}{4}$	G $\frac{1}{4}$	G $\frac{1}{4}$
Pilot air supply	–	–	Internal	External
Nominal size [mm]	6.0	6.0	6.0	6.0
Weight [g]	198	320	300	300
Actuating force [N]	80 ¹⁾ 140	38.0 ²⁾ 65.0	15.0	15.5

- 1) Value 80 with normally closed valve, value 140 with normally open valve
 2) Value 38 with mechanical spring reset method, value 65 with pneumatic spring reset method

Materials				
Type	VMEM-ST	VMEM-S	VMEM-SC	VMEM-SCZ
Cover	–	PA		
Seal	NBR			
Housing	Anodised wrought aluminium alloy			
Note on materials	RoHS-compliant			

Operating and environmental conditions				
Type	VMEM-ST	VMEM-S	VMEM-SC	VMEM-SCZ
Operating medium	Compressed air to ISO 8573-1:2010 [7:-:-]			
Note on operating/pilot medium	Lubricated operation possible (required during subsequent operation)			
Operating pressure range [bar]				
N/C valves	–0.95 ... 8	–	–	–
N/O valves	–0.95 ... 8	–0.95 ... 10 ¹⁾	2.5 ... 10 ²⁾	2.5 ... 10
Temperature of medium [°C]	–10 ... +60			
Ambient temperature [°C]	–10 ... +60			

- 1) Suitable for vacuum, mechanical spring or external pneumatic spring reset method (in the type codes Reset method M: Mechanical spring or E: External pneumatic spring)
 2) Not suitable for vacuum, internal pneumatic spring reset method (in the type codes Reset method A: Internal pneumatic spring)

Stem actuated valves

Sectional views

Sectional view

V-3-1/4-B, normally closed

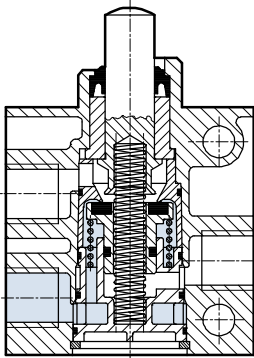

VO-3-1/4-B, normally open

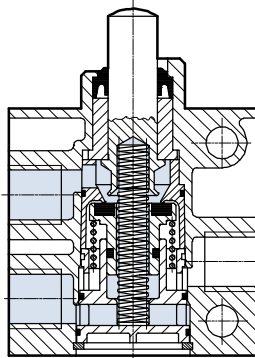

V/O-3-PK-3

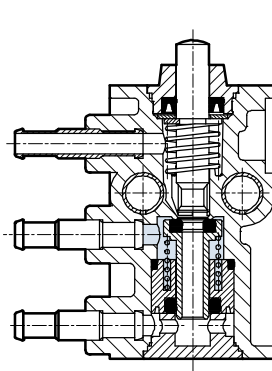

V/O-3-1/8

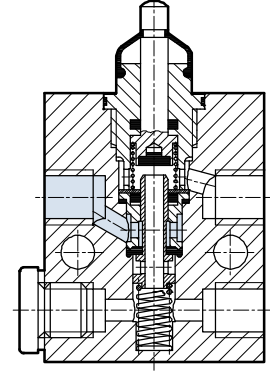

V ... -3-1/8, normally closed

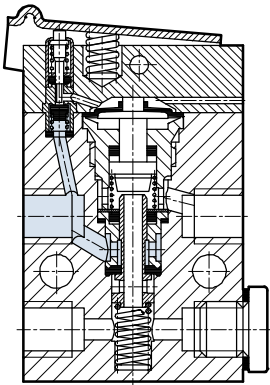

Actuator attachment at left
(number 1 on the attachment above
number 1 on the housing)

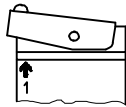

V ... -3-1/8, normally open

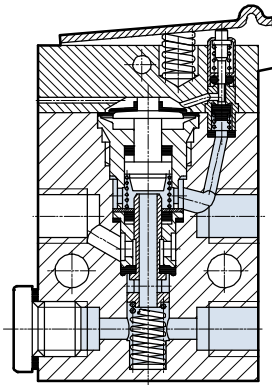

Actuator attachment at right
(number 1 on the attachment above
number 2 on the housing)

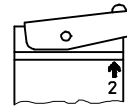

VS-4-1/8

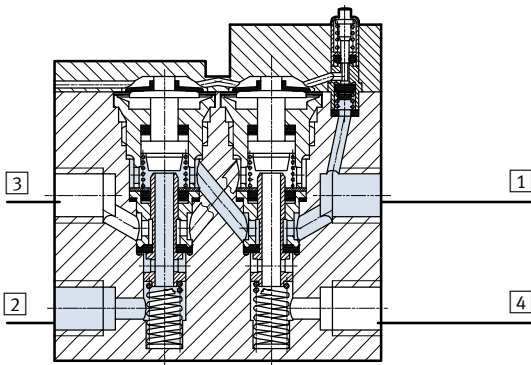

- 1 Supply port
- 2, 4 Working port
- 3 Exhaust port

V-3-M5

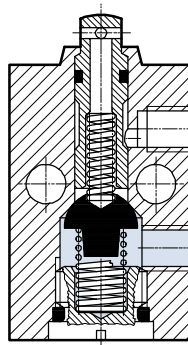

-  - Note

The sectional views, shown on the stem actuated valve, also apply in principle to the roller lever, toggle lever and swivel lever valves. The

function remains the same, only the operation via actuator attachments differs.

Stem actuated valves

Technical data



Dimensions

Download CAD data → www.festo.com

Stem actuated valve V-3-1/4-B, VO-3-1/4-B

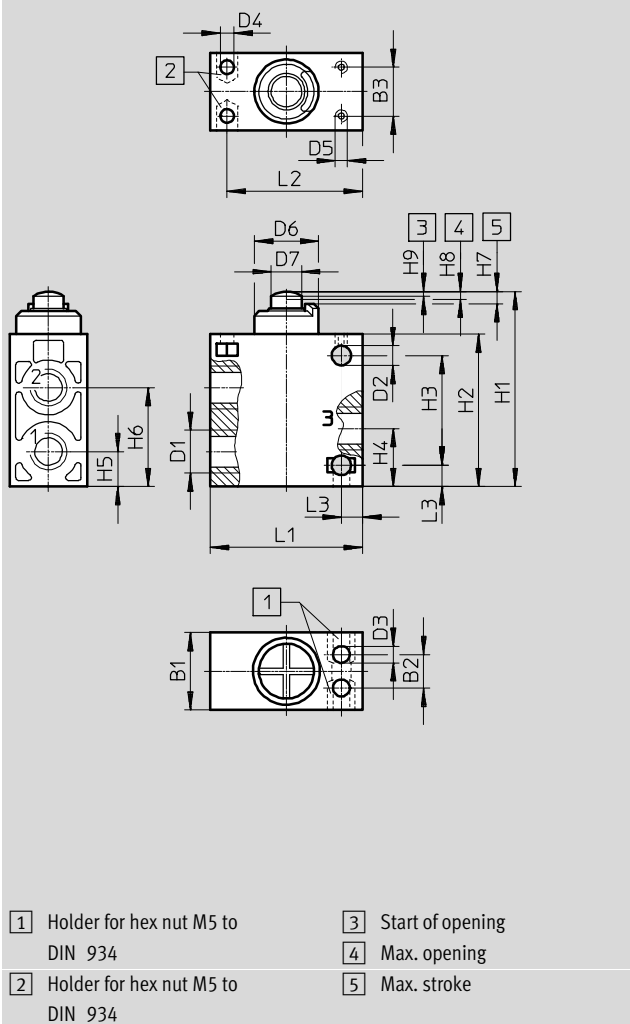

Stem actuated valve V-5-1/4-B

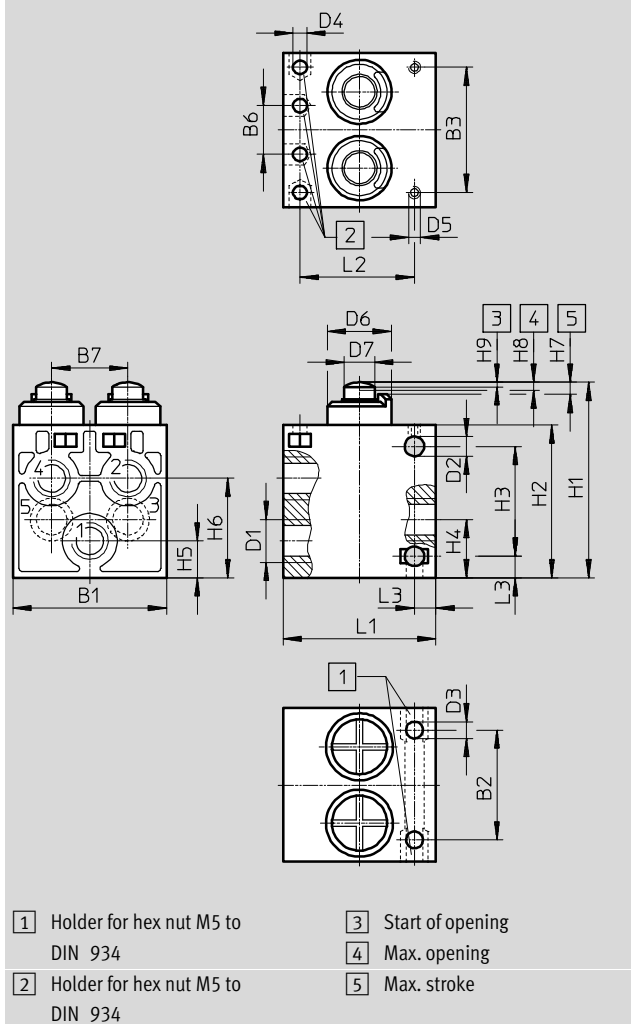

Stem actuated valve	B1	B2	B3	B6	B7	D1	D2	D3	D4	D5	D6	D7
V-3-1/4-B, VO-3-1/4-B	25.4	11	16	-	-	G1/4	6.4	5.5	4.5	M4	21	10
V-5-1/4-B	50.4	36	41	16	25	G1/4	6.4	5.5	4.5	M4	21	10

Stem actuated valve	L1	L2	L3	H1	H2	H3	H4	H5	H6	H7	H8	H9
V-3-1/4-B, VO-3-1/4-B	50	44.5	7	64	50	36	19	11.5	32.5	4	2.6	1.7
V-5-1/4-B	50	37.5	7	64	50	36	19	11.5	32.5	4	2.6	1.7

Stem actuated valves

Technical data

Dimensions

Download CAD data → www.festo.com

Stem actuated valve V/O-3-PK-3

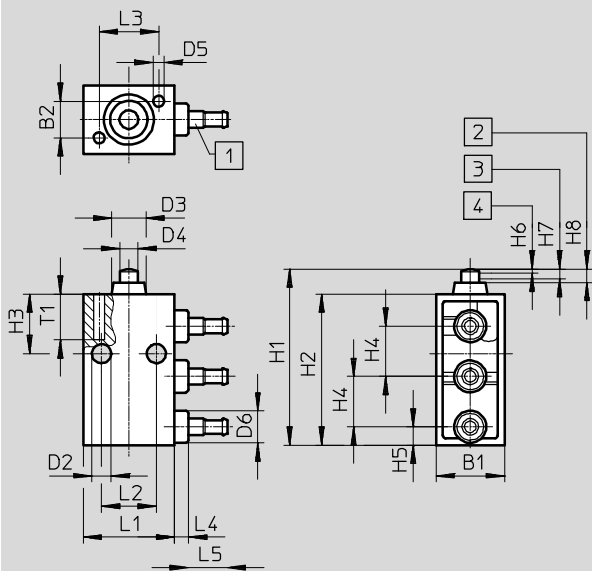

- 1 Barbed fitting for tubing I.D. 3 mm
- 2 Max. stroke
- 3 Max. opening
- 4 Start of opening

Stem actuated valve V-3-M5

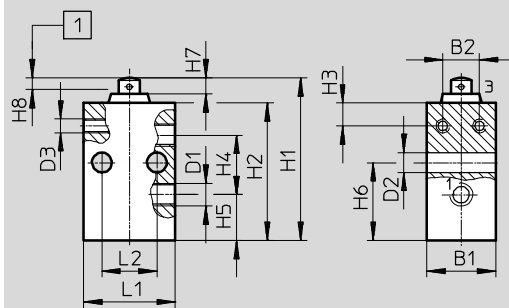

- 1 Max. stroke

Stem actuated valve VS-4-1/8

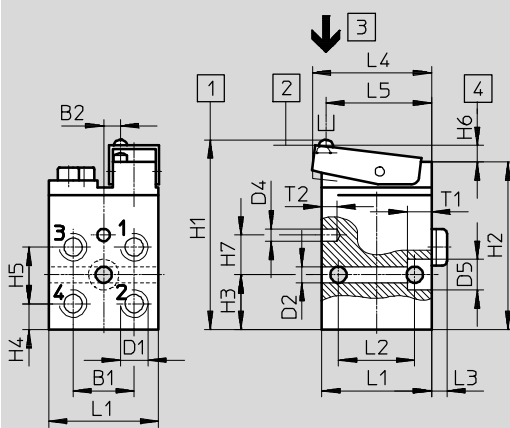

- 1 Initial position
- 2 ON position
- 3 Actuation direction
- 4 Smallest distance between cams

Stem actuated valve	B1	B2	D1	D2	D3	D4	D5	D6	T1	T2
V/O-3-PK-3	15	8	-	4.3	7.5	4	2.4	7	10	-
V-3-M5	15	8	M5	4.3	M3	-	-	-	-	-
VS-4-1/8	20	5.5	G1/8	5.3	-	4.1	10	-	8	5

Stem actuated valve	L1	L2	L3	L4	L5	H1	H2	H3	H4	H5	H6	H7	H8	H14
V/O-3-PK-3	20	12	13	3	8.5	38.5	33	13	11	4	0.9	2.1	2.9	-
V-3-M5	-	-	-	-	-	35.5	30	8	13	10	17	3.5	2.5	-
VS-4-1/8	36	25	5	39	35.5	62.5	55	18	8.5	18.5	5.5	-	-	13

Stem actuated valves

Technical data



Dimensions

Download CAD data → www.festo.com

Stem actuated valve V/O-3-1/8

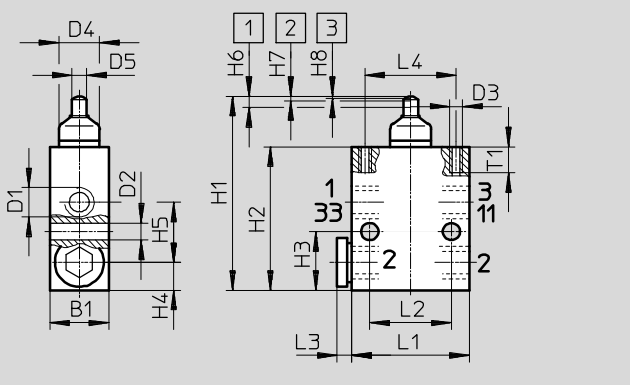

Roller lever AR-01 as actuator attachment for stem actuated valve V/O-3-1/8

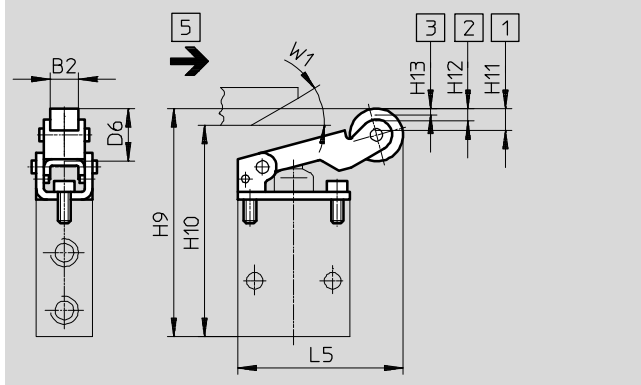

Roller lever with idle return AL-01 as actuator attachment for stem actuated valve V/O-3-1/8

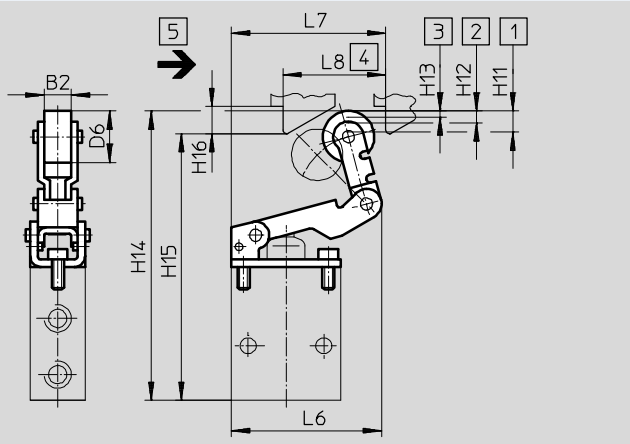

- 1 Max. stroke
- 2 Max. opening
- 3 Start of opening
- 4 Min. actuation stroke
- 5 Actuation direction

Stem actuated valve	B1	D1	D2	D3	D4	D5	L1	L2	L3	L4	H1	H2	H3	H4	H5	H6	H7	H8	T1	
V/O-3-1/8	18	G1/8	5.3	M4	12.5	4.5	36	25	4.5	28	59.5	44	18	8.5	18.5	3.5	1.4	±0.2	±0.2	8

Roller lever	B2	D6	L5	L6	L7	L8	H9	H10	H11	H12	H13	H14	H15	H16	W1
AR-01	8	17	54	-	-	-	71	64	7	4	2	-	-	-	30°
AL-01	8	17	-	50.5	51	34	-	-	7	4	2	93.5	86.5	9	-

Stem actuated valves

Technical data

Dimensions

Download CAD data → www.festo.com

Mounting bracket HV-M5

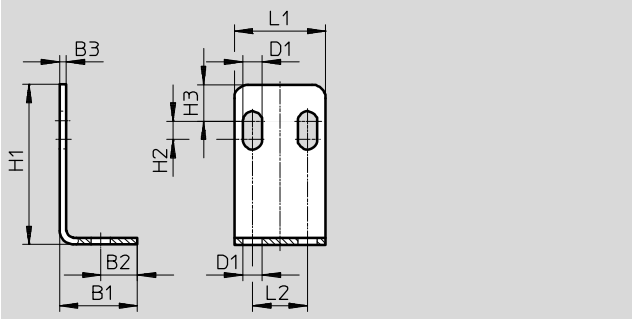

Mounting bracket HV-1/8

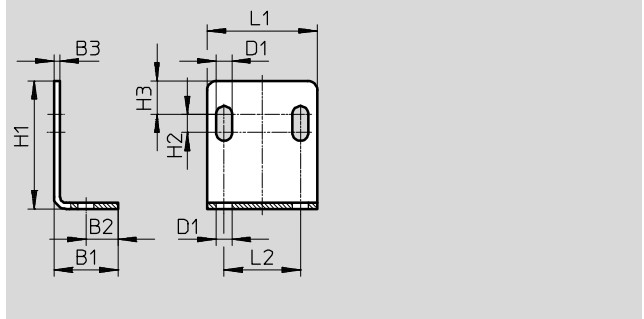

Mounting bracket	B1	B2	B3	D1	L1	L2	H1	H2	H3
HV-M5	17	8	1.5	4.3	20	12	35	4	8
HV-1/8	21	10.5	2	5.3	36	25	42	6	11

Stem actuated valves

Technical data



Dimensions

Download CAD data → www.festo.com

Stem actuated valve VMEM-ST-M32

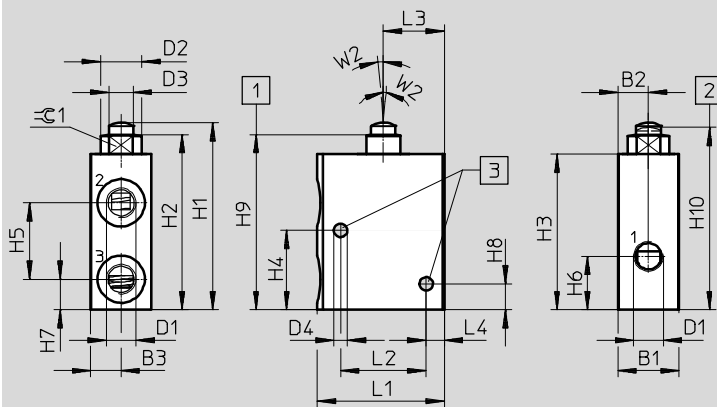

1 Maximum stroke 2 Start of opening 3 Mounting holes

Stem actuated valve	B1	B2	B3	D1	D2	D3	D4	L1	L2	L3	L4	∓C 1
VMEM-ST...32...G18	20	10	10	G ¹ / ₈	13.5	8	4.4	41.7	28	20	6	11
VMEM-ST...32...G14	25	12.5	12.5	G ¹ / ₄	15	10	4.4	52.1	36	25	7	13

Stem actuated valve	H1	H2	H3	H4	H5	H6	H7	H8	H9	H10±0.3	W2
VMEM-ST...32...G18	61.6±0.3	57.4	51	26	25	17.5	10	8.5	58.1±0.4	59.8	5°
VMEM-ST...32...G14	73.3±0.2	67.7	61	26	28	23.5	12.5	8	68.6±0.6	70.5	5°

Stem actuated valve VMEM-STC-M32...G18

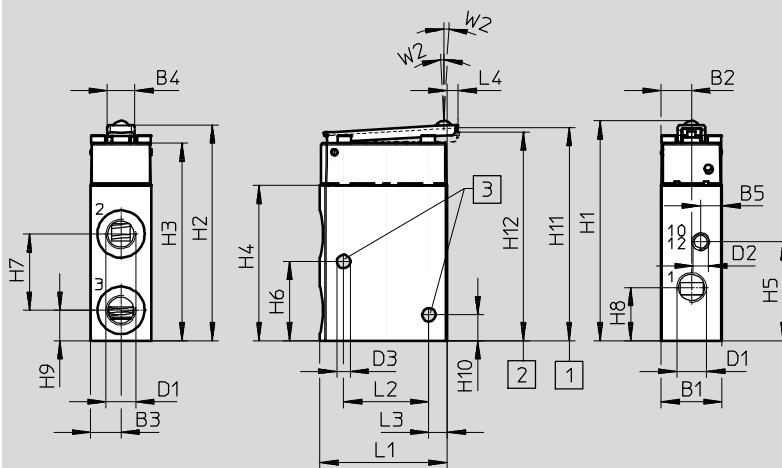

1 Maximum stroke 2 Start of opening 3 Mounting holes

Stem actuated valve	B1	B2	B3	B4	B5	D1	D2	D3	L1	L2	L3	L4	W2
VMEM-STC...32...G18	20	10	10	9	7	G ¹ / ₈	M5	4.4	41.7	28	6	3.5	3°

Stem actuated valve	H1±0.4	H2	H3	H4	H5	H6	H7	H8	H9	H10	H11±0.4	H12±0.15
VMEM-STC...32...G18	72.1	70.8	64.8	51	32.5	26	25	17.5	10	8.5	71.2	70.35

Stem actuated valves

Technical data

Dimensions

Download CAD data → www.festo.com

Stem actuated valve VMEM-S-M52

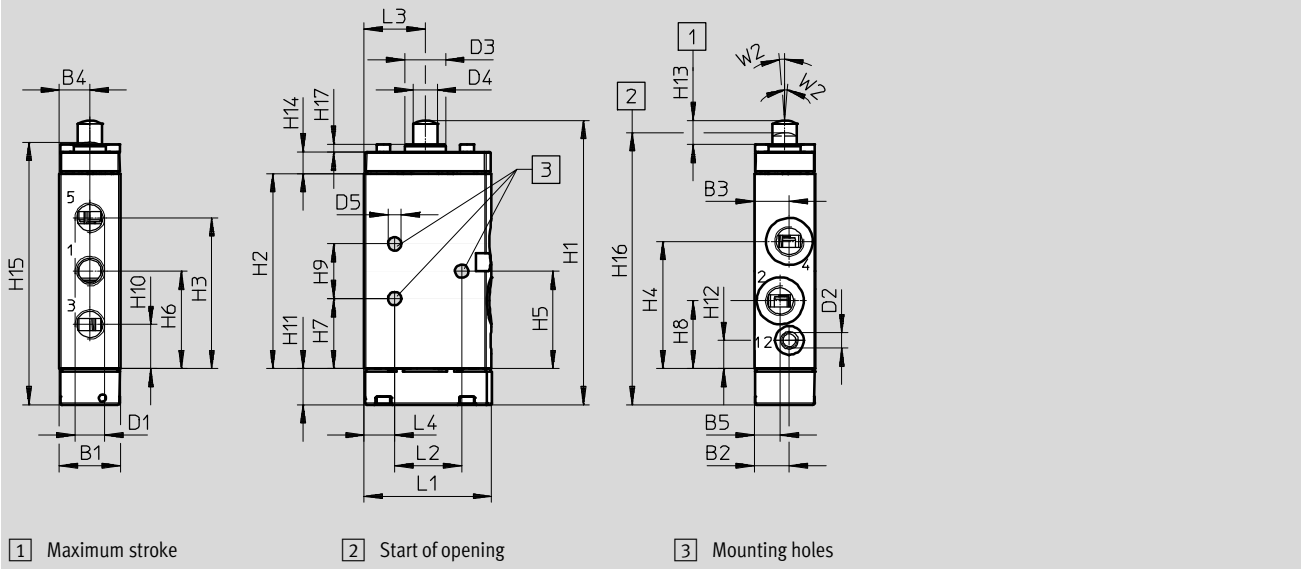

Stem actuated valve	B1	B2	B3	B4	B5	D1	D2	D3	D4	D5	L1	L2	L3	L4	W2
VMEM-S...52...G18	20	11.5	11.5	10	8.5	G $\frac{3}{8}$	M5	13.5	8	4.4	41.7	25	20	7	5°
VMEM-S...52...G14	25	14.2	14.2	12.5	10.8	G $\frac{1}{4}$	M5	15	10	4.4	52.1	31	25	9.5	5°

Stem actuated valve	H1	H2	H3	H4	H5	H6	H7	H8	H9	H10	H11	H12	H13	H14	H15	H16	H17
VMEM-S...52...G18	93.4±0.4	64	49.5	41.8	32	32	23	22.3	18	14.5	11.8	9.3	7.8	7.1	86.3±0.4	89.4±1	2.5
VMEM-S...52...G14	118.5±0.3	87	68.1	60.1	43.5	43.8	31.4	28.5	24.3	19.5	11	10.1	9	8.3	110.1±0.3	113.7±1.3	3

Stem actuated valves

Technical data

FESTO

Dimensions

Download CAD data → www.festo.com

Stem actuated valve VMEM-SC ... -M52

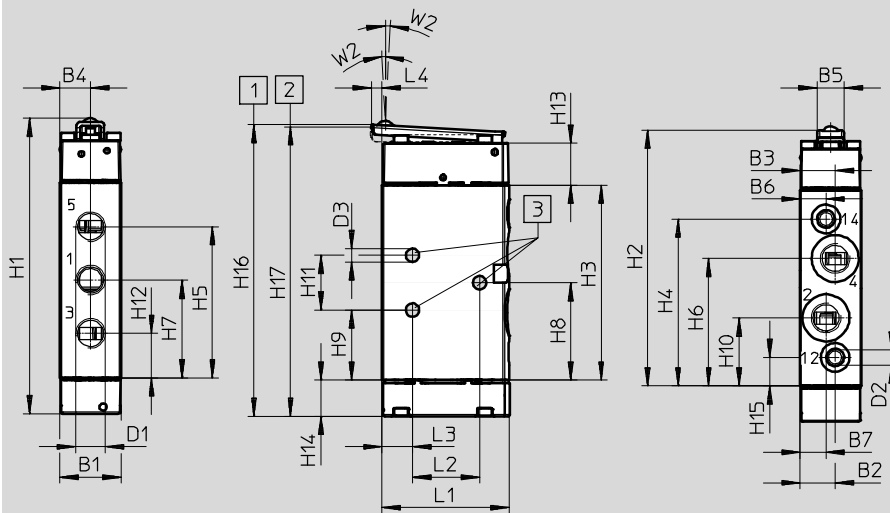

- 1 Maximum stroke
- 2 Start of opening
- 3 Mounting holes

Stem actuated valve	B1	B2	B3	B4	B5	B6	B7	D1	D2	D3	L1	L2	L3	L4	W2
VMEM-SC...52...G18	20	11.5	11.5	10	9	8.5	8.5	G1/8	M5	4.4	41.7	25	7	3.5	3°
VMEM-SC...52...G14	25	14.2	14.2	12.5	12	10.8	10.8	G1/4	M5	4.4	52.1	31	9.5	4.6	3°

Stem actuated valve	H1±0.4	H2	H3	H4	H5	H6	H7	H8	H9	H10	H11	H12	H13	H14	H15	H16±0.4	H17+0.5
VMEM-SC...52...G18	96.9	83.8	64	54.7	49.5	41.8	32	32	23	22.3	18	14.5	13.8	11.8	9.3	95.6	95.1
VMEM-SC...52...G14	119.4	106.8	87.3	77.5	68.1	59.1	43.8	43.5	31.4	28.5	24.3	19.5	13.8	11	10.1	117.8	117.4

Stem actuated valves



Ordering data

Ordering data								
Nominal flow rate	Valve function	Description	Mechanical reset	Normal position	Pilot air ¹⁾	Part No.	Type	
Stem actuated valve								
80 l/min	3/2-way valve, monostable	Suitable for vacuum	■	Closed	–	3626	V-3-M5	
		Suitable for vacuum	■	Open/closed	–	10747	V/O-3-PK-3	
120 l/min	3/2-way valve, monostable	–	■	Closed	–	2334	VS-3-1/8	
		–	■	Closed	–	2952	VOS-3-1/8	
	4/2-way valve, monostable	–	■	–	–	3394	VS-4-1/8	
140 l/min	3/2-way valve, monostable	Suitable for vacuum	■	Open/closed	–	4938	V/O-3-1/8	
500 l/min	3/2-way valve, monostable	Suitable for vacuum	■	Closed	–	555618	VMEM-ST-M32C-M-G18	
				Open	–	555619	VMEM-ST-M32U-M-G18	
		–	■	Closed	Internal	555620	VMEM-STC-M32C-M-G18	
				External	555622	VMEM-STCZ-M32C-M-G18		
			■	Open	Internal	555621	VMEM-STC-M32U-M-G18	
				External	555623	VMEM-STCZ-M32U-M-G18		
		Suitable for vacuum, reverse operation	■	–	–	–	555624	VMEM-S-M52-M-G18
		(Internal) pneumatic reset	–	–	–	–	555625	VMEM-S-M52-A-G18
		Suitable for vacuum, reverse operation, (external) pneumatic reset	–	–	–	–	555626	VMEM-S-M52-E-G18
		–	■	–	Internal	555627	VMEM-SC-M52-M-G18	
		Suitable for vacuum, reverse operation		–	External	555629	VMEM-SCZ-M52-M-G18	
		–	■	–	Internal	555628	VMEM-SC-M52-A-G18	
		Suitable for vacuum, reverse operation		–	External	555630	VMEM-SCZ-M52-E-G18	
550 l/min	5/2-way valve, monostable	Suitable for vacuum	■	–	–	6809	V-5-1/4-B	
600 l/min	3/2-way valve, monostable	Suitable for vacuum	■	Closed	–	6808	V-3-1/4-B	
				Open	–	9157	VO-3-1/4-B	
1,000 l/min	3/2-way valve, monostable	Suitable for vacuum	■	Closed	–	556901	VMEM-ST-M32C-M-G14	
				Open	–	556902	VMEM-ST-M32U-M-G14	
	5/2-way valve, monostable	Suitable for vacuum, reverse operation	■	–	–	556903	VMEM-S-M52-M-G14	
	–	–		–	–	556904	VMEM-S-M52-A-G14	
	Suitable for vacuum, reverse operation	–	–	–	556905	VMEM-S-M52-E-G14		
	–	■	–	Internal	556906	VMEM-SC-M52-M-G14		
	Suitable for vacuum, reverse operation		–	External	556908	VMEM-SCZ-M52-M-G14		
	–	■	–	Internal	556907	VMEM-SC-M52-A-G14		
	Suitable for vacuum, reverse operation		–	External	556909	VMEM-SCZ-M52-E-G14		

1) With piloted valves

Swivel lever valves

Technical data – Swivel lever valve, standard nominal flow rate 140 l/min

-  Flow rate
140 l/min
-  Pressure
-0.95 ... 8 bar
-  Temperature range
-10 ... +60 °C

Mounting via through-holes



General technical data		
Type	RW/O-3-1/8	
Standard nominal flow rate [l/min]	140	
1 → 2		
Valve function	3/2-way valve	
Design	Disk seat valve, directly actuated	
Pneumatic connection	G1/8	
Nominal size [mm]	3.5	
Weight [g]	150	
Actuating force at 6 bar [N]	28.0	

Materials	
Seal	NBR
Housing	Anodised aluminium

Operating and environmental conditions	
Operating medium	Compressed air to ISO 8573-1:2010 [7:-:-]
Note on operating/pilot medium	Lubricated operation possible (required during subsequent operation)
Operating pressure range [bar]	-0.95 ... 8
Temperature of medium [°C]	-10 ... +60

Technical data – Actuator attachment for swivel lever valve RW/O-3-1/8				
Swivel lever, type		ASK-02 (short)	ASL-02 (long)	ASS-02 (rod)
Actuating force [N]	Max.	7	Dependent on starting height	Dependent on starting height
Weight [g]		30	35	30

Materials – Swivel lever	
Swivel lever	Aluminium, steel

Swivel lever valves

Technical data

Dimensions

Download CAD data → www.festo.com

Swivel lever valve RW/O-3-1/8

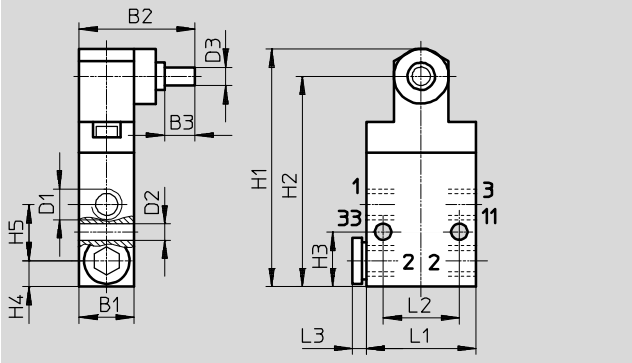

Mounting bracket HV-1/8

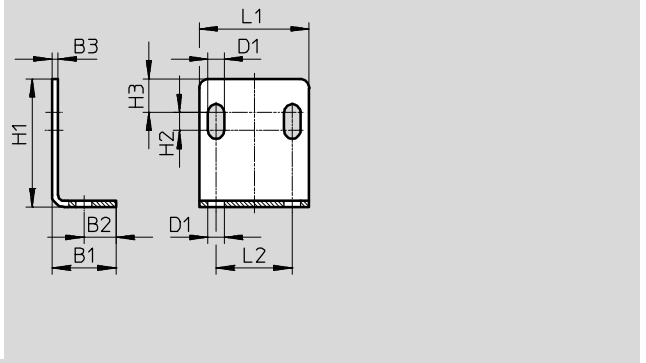

	B1	B2	B3	D1	D2	D3	L1	L2	L3	H1	H2	H3	H4	H5
Swivel lever valve RW/O-3-1/8	18	38	10	G1/8	5.3	6	36	25	4.5	78	69	18	8.5	18.5
Mounting bracket HV-1/8	21	10.5	2	5.3	-	-	36	25	-	42	6	11	-	-

Actuator attachment for swivel lever valve RW/O-3-1/8

Swivel lever, short ASK-02

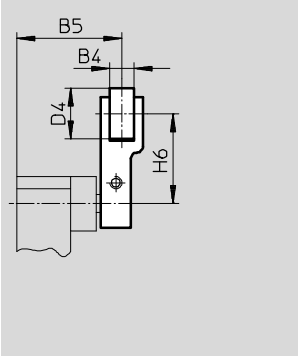

Swivel lever, long ASL-02

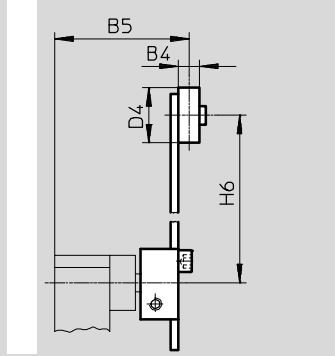

Swivel lever rod ASS-02

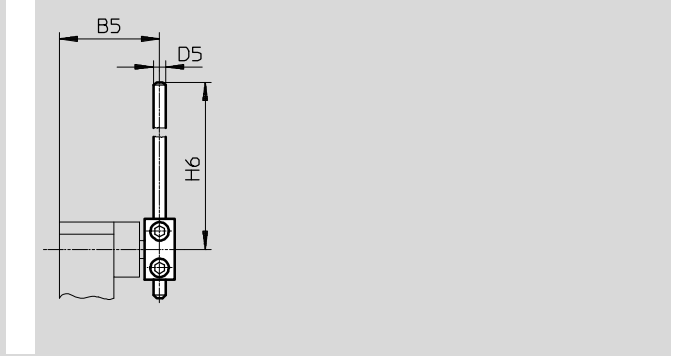

Actuator attachment	B4	B5	D4	D5	D6	H6
ASK-02	8	35	17	-	-	30
ASL-02	7	44	18	-	-	25 ... 85
ASS-02	-	33	-	4	4	30 ... 140

Swivel lever valves

Technical data

FESTO

Actuating ranges are set by converting the switching head

Default settings (upon delivery)

Valve components 1 and 2 turned 90° around the longitudinal axis

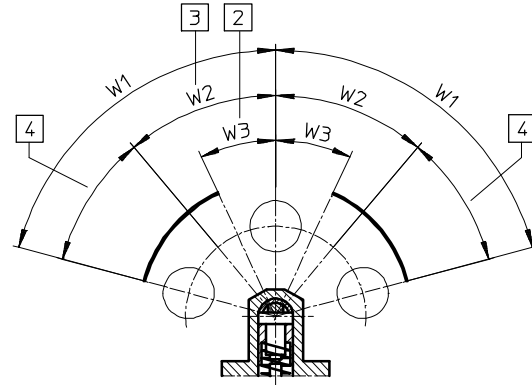
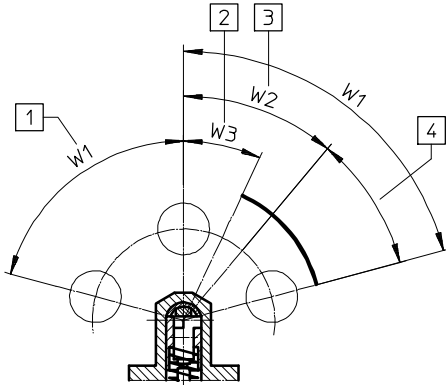

Valve components 1 and 2 turned 180° around the longitudinal axis

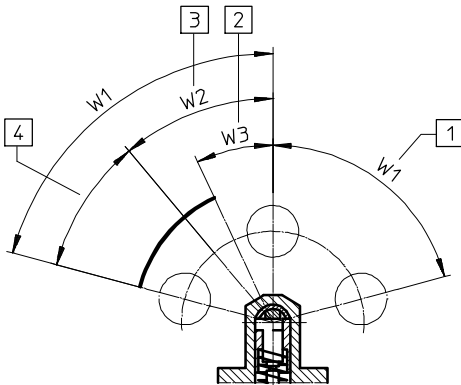



- 1 (w1) Idling, or max. angle position (75°)
- 2 (w3) Start of opening (25° ± 8°)
- 3 (w2) Max. opening angle (40° ± 5°)
- 4 Overtravel

Ordering data

Nominal flow rate	Valve function	Description	Mechanical reset	Normal position	Part No.	Type
Swivel lever valve						
140 l/min	3/2-way valve, monostable	Suitable for vacuum	■	Open/closed	4937	RW/O-3-1/8



Ordering data

Description	Part No.	Type	PU ¹⁾
Actuator attachment			
 For swivel lever valve RW/O-3-1/8, short swivel lever	5835	ASK-02	1
 For swivel lever valve RW/O-3-1/8, long swivel lever	5836	ASL-02	1
 For swivel lever valve RW/O-3-1/8, swivel lever rod	4789	ASS-02	1

1) Packaging unit

Whisker valves

Technical data – Whisker valve, standard nominal flow rate 120 l/min

-  Flow rate
120 l/min
 -  Pressure
3.5 ... 8 bar
 -  Temperature range
-10 ... +60 °C
- Mounting via through-holes



General technical data	
Type	Whisker valve FVS, FVSO
Standard nominal flow rate [l/min] 1 → 2	120
Valve function	3/2-way valve
Design	Disk seat valve, piloted
Pneumatic connection	G $\frac{1}{8}$
Nominal size [mm]	3.5
Weight [g]	130
Actuating force at 6 bar [N]	→ Graph
Repetition accuracy of switching point [mm]	±0.1

Materials	
Seal	NBR
Housing	Anodised aluminium

Operating and environmental conditions	
Operating medium	Compressed air to ISO 8573-1:2010 [7:-:-]
Note on operating/pilot medium	Lubricated operation possible (required during subsequent operation)
Operating pressure range [bar]	3.5 ... 8
Temperature of medium [°C]	-10 ... +60
Ambient temperature [°C]	-10 ... +60

Whisker valves

Technical data

FESTO

Switching forces F and switching travel l at 6 bar as a function of approach distance L

Whisker valve

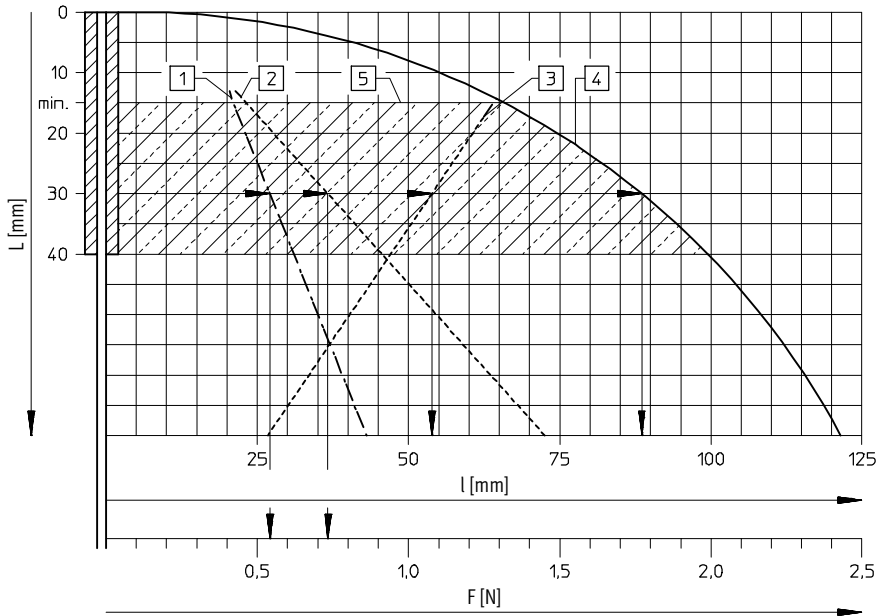

This piloted valve with extremely low actuating forces is particularly suited for systems where dissimilar parts or actuating elements without precision positioning are to be sensed, or where the actuating levels are different. The whisker can be approached from any direction perpendicular to the whisker axis, or can be passed.

- 1 Switching force
- 2 Passing force
- 3 Switching travel
- 4 Overtravel
- 5 Permissible approach range

Example:

A distance of 30 mm from the end of the spring results in:

Switching travel 54 mm
Switching force 0.57 N

Overtravel 88 mm
Passing force 0.75 N

Whisker valves

Technical data

Dimensions

Download CAD data → www.festo.com

Whisker valve FVS, FVSO

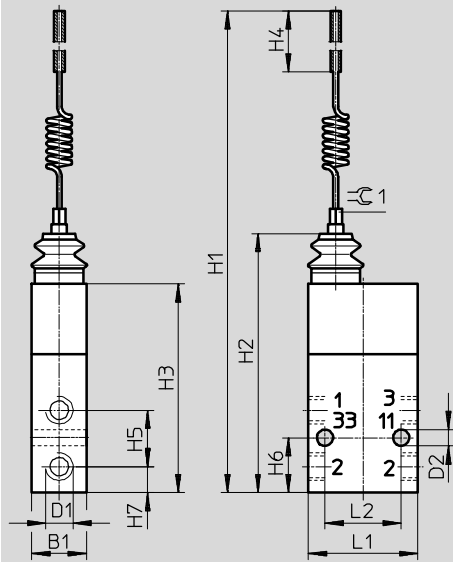

Whisker valve	B1	D1	D2	H1	H2	H3	H4 max.	H5	H6	H7	L1	L2	⌀ 1
FVS, FVSO	18	G $\frac{1}{8}$	5.3	220	85	68.5	40	18.5	18	8.5	36	25	4

Ordering data

Nominal flow rate	Valve function	Description	Mechanical reset	Normal position	Pilot air ¹⁾	Part No.	Type
Whisker valve							
120 l/min	3/2-way valve, monostable	Whisker valve	■	Closed	Internal	3876	FVS-3-$\frac{1}{8}$
				Open	Internal	3877	FVSO-3-$\frac{1}{8}$

1) With piloted valves

Roller lever valves with idle return, toggle lever valves

Technical data – Roller lever valve with idle return, toggle lever valve, standard nominal flow rate 80 ... 120 l/min

-  Flow rate
80 ... 600 l/min

Mounting via through-holes

-  Pressure
-0.95 ... 8 bar

-  Temperature range
-10 ... +60 °C



General technical data				
Type	L/O-3-PK-3	L-3-M5	LS-3-1/8 LOS-3-1/8	LS-4-1/8
Version	Roller lever valve with idle return	Roller lever valve with idle return	Toggle lever valve	Toggle lever valve
Standard nominal flow rate [l/min] 1 → 2	80		120	
Valve function	3/2-way valve		3/2-way valve	4/2-way valve
Design	Disk seat valve, directly actuated		Disk seat valve, piloted	Disk seat valve, piloted
Pneumatic connection	PK-3 (barbed fitting for plastic tubing with 3 mm nominal diameter)	M5	G1/8	G1/8
Nominal size [mm]	2.5	2	3.5	3.5
Weight [g]	19	43	110	220
Actuating force [N]	-	16.5	-	2.2
• at 6 bar				
• with normally closed position	[N] 10.0	-	1.8	-
• with normally open position	[N] 13.0	-	1.8	-

Materials				
Type	L/O-3-PK-3	L-3-M5	LS-3-1/8 LOS-3-1/8	LS-4-1/8
Seal	NBR			
Housing	POM	Die-cast zinc	Anodised aluminium	Anodised aluminium

Operating and environmental conditions				
Type	L/O-3-PK-3	L-3-M5	LS-3-1/8 LOS-3-1/8	LS-4-1/8
Operating medium	Compressed air to ISO 8573-1:2010 [7:-:-]			
Note on operating/pilot medium	Lubricated operation possible (required during subsequent operation)			
Operating pressure range [bar]	0 ... 8	-0.95 ... 8	3.5 ... 8	3.5 ... 8
Ambient temperature [°C]	-10 ... +60			

Roller lever valves with idle return, toggle lever valves

FESTO

Technical data – Roller lever valve with idle return, toggle lever valve, standard nominal flow rate 550 ... 600 l/min

General technical data		
Type	L-5-1/4-B	L-3-1/4-B LO-3-1/4-B
Version	Toggle lever valve	Toggle lever valve
Standard nominal flow rate [l/min] 1 → 2	550	600
Valve function	5/2-way valve	3/2-way valve
Design	Disk seat valve, directly actuated	Disk seat valve, directly actuated
Pneumatic connection	G1/4	G1/4
Nominal size [mm]	7.0	7.0
Weight [g]	360	250
Actuating force [N]	53.0	15.0 ¹⁾ 38.0

1) Value 15.0 with normally closed valve, value 38.0 with normally open valve

Materials	
Seal	NBR
Housing	Die-cast aluminium

Operating and environmental conditions	
Operating medium	Compressed air to ISO 8573-1:2010 [7:-:-]
Note on operating/pilot medium	Lubricated operation possible (required during subsequent operation)
Operating pressure range [bar]	-0.95 ... 10
Ambient temperature [°C]	-10 ... +60

Roller lever valves with idle return, toggle lever valves

Technical data

Dimensions

Download CAD data → www.festo.com

Roller lever valve with idle return L/O-3-PK-3

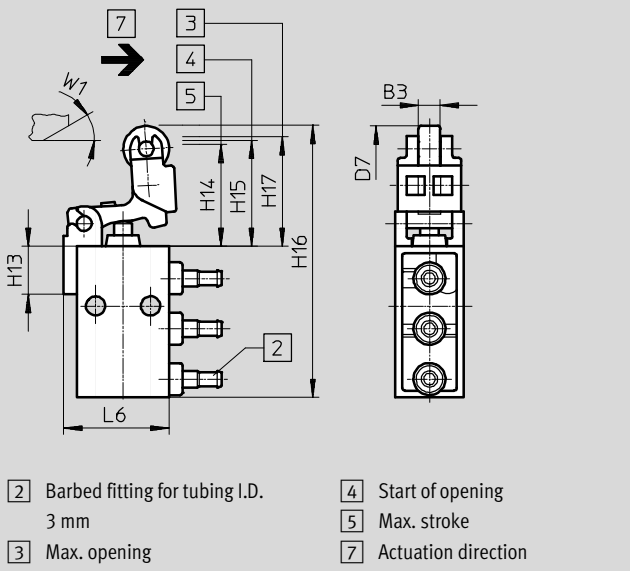

Roller lever valve with idle return L-3-M5

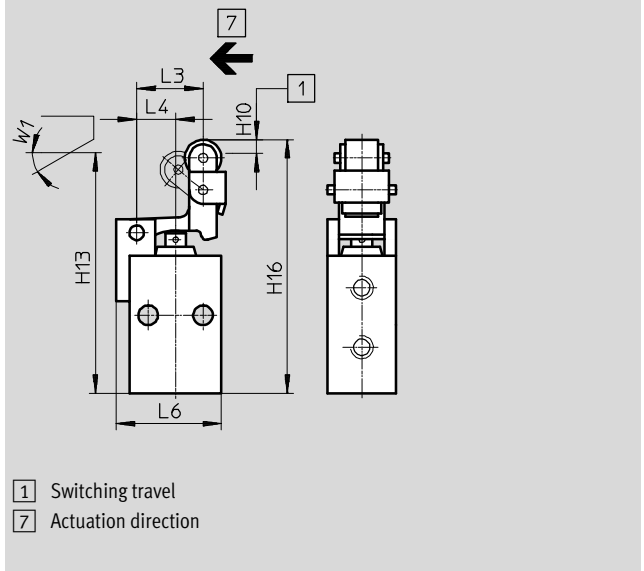

Roller lever valve with idle return L-3-1/4-B, LO-3-1/4-B

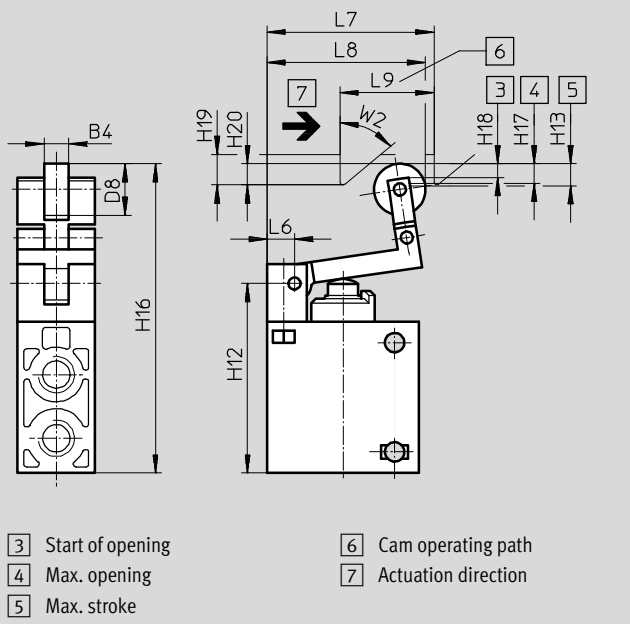

Roller lever valve with idle return L-5-1/4-B

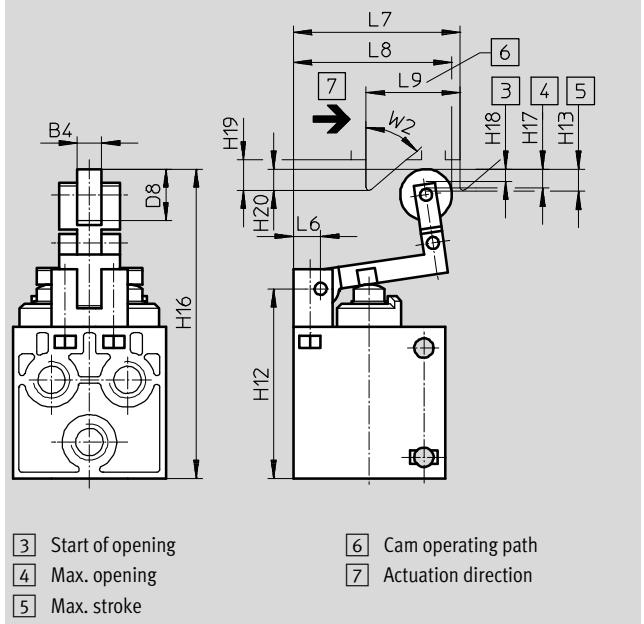

Roller lever valve with idle return	B3	B4	D7	D8	L3	L4	L6	L7	L8	L9
L/O-3-PK-3	4.8	-	10	-	-	-	23	-	-	-
L-3-M5	-	-	-	-	14.5	8.5	23	-	-	-
L-3-1/4-B, LO-3-1/4-B	-	8	-	17	-	-	9	55	54	31
L-5-1/4-B	-	8	-	17	-	-	9	55	54	31

Roller lever valve with idle return	H10	H12	H13	H14	H15	H16	H17	H18	H19	H20	W1	W2
L/O-3-PK-3	-	-	10.5	22.3	23.2	59.5	24	-	-	-	30°	-
L-3-M5	3	-	52.5	-	-	55.5	-	-	-	-	30°	-
L-3-1/4-B, LO-3-1/4-B	-	62.5	7.4	-	-	102	6.3	4.1	10	7	-	50°
L-5-1/4-B	-	62.5	7.4	-	-	102	6.3	4.1	10	7	-	50°

Roller lever valves with idle return, toggle lever valves

Technical data

Dimensions

Download CAD data → www.festo.com

Toggle lever valve LS-3-1/8, LOS-3-1/8

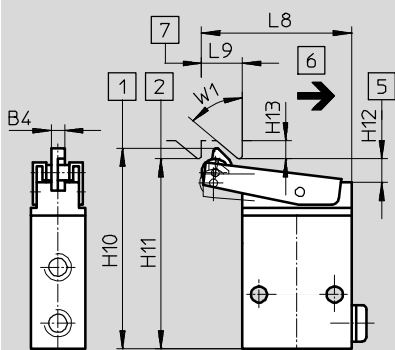

- 1 Initial position
- 2 ON position
- 5 Bottom edge of control rail or cam
- 6 Idle return
- 7 Min. switching travel

Toggle lever valve LS-4-1/8

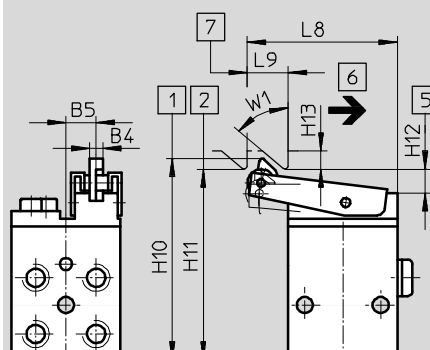

- 1 Initial position
- 2 ON position
- 5 Bottom edge of control rail or cam
- 6 Idle return
- 7 Min. switching travel

Toggle lever valve	B4	B5	L8	L9	H10	H11	H12 +0.2, -0.3	H13	W1
LS-3-1/8, LOS-3-1/8	4.4	-	49.5	13.5	66	62.5	7.5	6	50°
LS-4-1/8	4.4	9	49.5	13.5	66	62.5	7.5	6	50°

Mounting bracket HV-M5

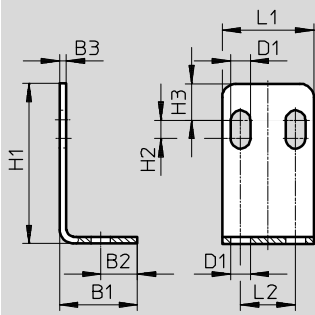

Mounting bracket HV-1/8

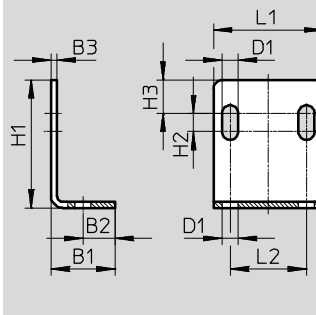

Mounting bracket	B1	B2	B3	D1	L1	L2	H1	H2	H3
HV-M5	17	8	1.5	4.3	20	12	35	4	8
HV-1/8	21	10.5	2	5.3	36	25	42	6	11

Roller lever valves with idle return, toggle lever valves

FESTO

Ordering data

Ordering data						
Nominal flow rate	Valve function	Description	Mechanical reset	Normal position	Part No.	Type
Toggle lever valve						
120 l/min	3/2-way valve, monostable	Toggle lever valve	■	Closed	2186	LS-3-1/8
				Open	2950	LOS-3-1/8
	4/2-way valve, monostable	Toggle lever valve	■	–	3416	LS-4-1/8
Roller lever valve with idle return						
80 l/min	3/2-way valve, monostable	Roller lever valve with idle return	■	Open/closed	10749	L/O-3-PK-3
		Roller lever valve with idle return, suitable for vacuum		Closed	3628	L-3-M5
550 l/min	5/2-way valve, monostable	Roller lever valve with idle return, suitable for vacuum	■	–	8993	L-5-1/4-B
600 l/min	3/2-way valve, monostable	Roller lever valve with idle return, suitable for vacuum	■	Closed	8982	L-3-1/4-B
				Open	8989	LO-3-1/4-B

Ordering data					
	Description	Part No.	Type	PU ¹⁾	
Actuator attachment					
	For roller lever valve with idle return L-3-M5, roller lever with idle return with mounting screws	6513	AL-05	1	

1) Packaging unit

Roller lever valves, roller actuated valves

FESTO

Technical data – Roller lever valve, roller actuated valve, standard nominal flow rate 80 ... 120 l/min

 Flow rate
80 ... 500 l/min

Mounting either via through-holes or
on front panel

 Pressure
-0.95 ... 10 bar

 Temperature range
-10 ... +60 °C



General technical data				
Type	R/O-3-PK-3	R-3-M5	RS-3-1/8 ROS-3-1/8	RS-4-1/8
Version	Roller lever valve	Roller lever valve	Roller lever valve	Roller lever valve
Standard nominal flow rate [l/min] 1 → 2	80		120	
Valve function	3/2-way valve		3/2-way valve	4/2-way valve
Design	Disk seat valve, directly actuated		Disk seat valve, piloted	
Pneumatic connection	PK-3 (barbed fitting for plastic tubing with 3 mm nominal diameter)	M5	G1/8	G1/8
Nominal size [mm]	2.5	2	3.5	3.5
Weight [g]	18	40	120	230
Actuating force [N]	-	16.5	1.8	1.8
• at 6 bar				
• with normally closed position	[N] 10.0	-	-	-
• with normally open position	[N] 15.0	-	-	-

Materials				
Type	R/O-3-PK-3	R-3-M5	RS-3-1/8 ROS-3-1/8	RS-4-1/8
Seal	NBR			
Housing	POM	Die-cast zinc	Anodised aluminium	Anodised aluminium

Operating and environmental conditions				
Type	R/O-3-PK-3	R-3-M5	RS-3-1/8 ROS-3-1/8	RS-4-1/8
Operating medium	Compressed air to ISO 8573-1:2010 [7:-:-]			
Note about operating/pilot medium	Lubricated operation possible (required during subsequent operation)			
Operating pressure range [bar]	0 ... 8	-0.95 ... 8	3.5 ... 8	3.5 ... 8
Ambient temperature [°C]	-10 ... +60			

Technical data – Actuator attachment		
Type	AR-01	AL-01
Version	Roller lever	Roller lever with idle return
Actuating force [N] Max.	10	12
Weight [g]	42	52

Materials – Actuator attachment	
Actuator attachment	Galvanised steel

Roller lever valves, roller actuated valves

Technical data – Roller lever valve, roller actuated valve, standard nominal flow rate 550 ... 600 l/min

General technical data		
Type	R-5-1/4-B	R-3-1/4-B RO-3-1/4-B
Version	Roller lever valve	Roller lever valve
Standard nominal flow rate [l/min] 1 → 2	550	600
Valve function	5/2-way valve	3/2-way valve
Design	Disk seat valve, directly actuated	Disk seat valve, directly actuated
Pneumatic connection	G1/4	G1/4
Nominal size [mm]	7.0	7.0
Weight [g]	340	230
Actuating force [N]	35.0	10.0 ¹⁾ 26.0

1) Value 10.0 with normally closed valve, value 26.0 with normally open valve

Materials	
Seal	NBR
Housing	Die-cast aluminium

Operating and environmental conditions	
Operating medium	Compressed air to ISO 8573-1:2010 [7:-:-]
Note on operating/pilot medium	Lubricated operation possible (required during subsequent operation)
Operating pressure range [bar]	-0.95 ... 10
Ambient temperature [°C]	-10 ... +60

Roller lever valves, roller actuated valves

Technical data – Roller lever valve, roller actuated valve, standard nominal flow rate 500 l/min

General technical data			
Type		VMEM-DT	VMEM-D
Standard nominal flow rate	[l/min]	500	
1 → 2			
Valve function		3/2-way valve	5/2-way valve
Reset method		Mechanical spring	Mechanical or pneumatic spring
Design		Disk seat valve, directly actuated	Piston spool valve, directly actuated
Pneumatic connection		G $\frac{1}{8}$	G $\frac{1}{8}$
Pilot air supply		–	–
Nominal size	[mm]	4.0	4.0
Weight	[g]	160	176
Max. switching frequency	[Hz]	2	2
Max. actuating speed			
• Axial actuation	[m/s]	0.6	0.6
• Lateral actuation	[m/s]	0.2	0.2
Actuating force	[N]	90 ¹⁾ 130	27.5 ²⁾ 41
Max. actuating force	[N]	80	150
Max. lateral force	[N]	30	30

- 1) Value 90 with normally closed valve, value 130 with normally open valve
 2) Value 27.5 with mechanical spring reset method, value 41 with pneumatic spring reset method

Materials	
Cover	PA
Seal	NBR
Housing	Anodised wrought aluminium alloy
Note on materials	RoHS-compliant

Operating and environmental conditions			
Type		VMEM-DT	VMEM-D
Operating medium		Compressed air to ISO 8573-1:2010 [7:-:-]	
Note on operating/ pilot medium	[μ m]	Lubricated operation possible (required during subsequent operation)	
Operating pressure range	[bar]	–0.95 ... 8	–0.95 ... 10 ¹⁾ 2.5 ... 10 ²⁾
Pilot pressure	[bar]	–	2.5 ... 10 ³⁾
Temperature of medium	[°C]	–10 ... +60	
Ambient temperature	[°C]	–10 ... +60	
Corrosion resistance class CRC ⁴⁾		2	

- 1) Suitable for vacuum, mechanical spring or external pneumatic spring reset method (in the type codes Reset method M: Mechanical spring or E: External pneumatic spring)
 2) Not suitable for vacuum, internal pneumatic spring reset method (in the type codes Reset method A: Internal pneumatic spring)
 3) With VMEM-D ... E ...
 4) Corrosion resistance class CRC 2 to Festo standard FN 940070
 Moderate corrosion stress. Indoor applications in which condensation may occur. External visible parts with primarily decorative requirements for the surface and which are in direct contact with the ambient atmosphere typical for industrial applications.

Roller lever valves, roller actuated valves

Technical data



Dimensions

Download CAD data → www.festo.com

Roller lever valve R/O-3-PK-3

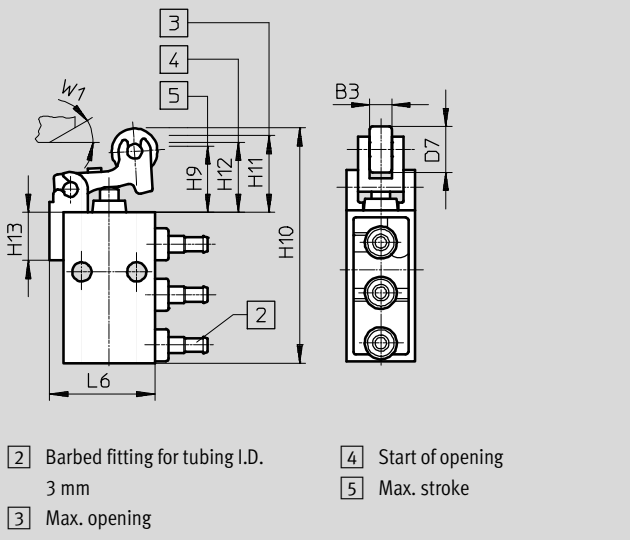

Roller lever valve R-3-M5

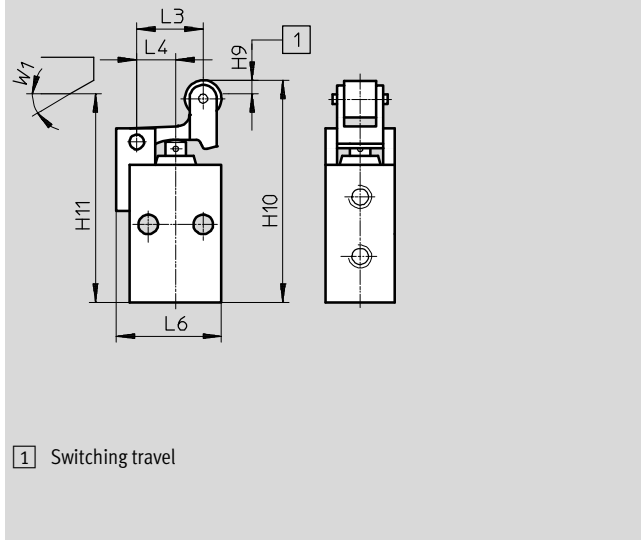

Roller lever valve R-3-1/4-B, RO-3-1/4-B

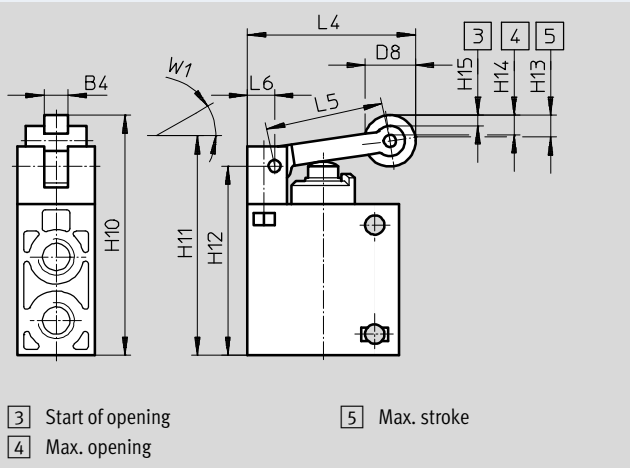

Roller lever valve R-5-1/4-B

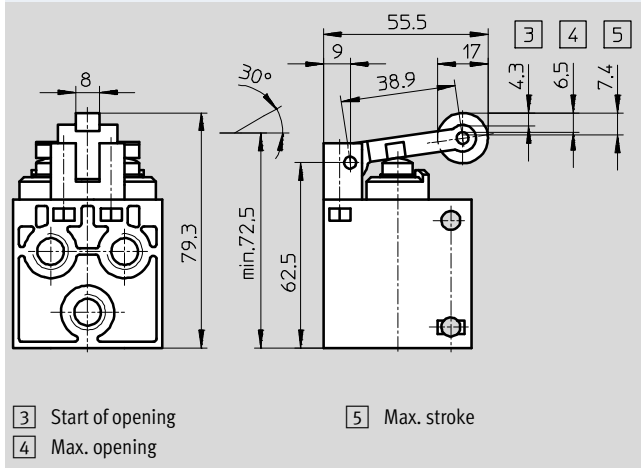

Roller lever valve	B3	B4	D7	D8	L3	L4	L5	L6
R/O-3-PK-3	4.8	-	10	-	-	-	-	23
R-3-M5	-	-	-	-	14.5	8.5	-	23
R-3-1/4-B, RO-3-1/4-B	-	8	-	17	-	55.5	39	9
R-5-1/4-B	-	8	-	17	-	55.5	39	9

Roller lever valve	H9	H10	H11	H12	H13	H14	H15	W1
R/O-3-PK-3	14.5	51.5	16.8	18.5	10.5	-	-	30°
R-3-M5	3	48.5	45.5	-	-	-	-	30°
R-3-1/4-B, RO-3-1/4-B	-	79.3	min. 72.5	62.5	7.4	6.5	4.3	30°
R-5-1/4-B	-	79.3	min. 72.5	62.5	7.4	6.5	4.3	30°

Roller lever valves, roller actuated valves

Technical data

Dimensions

Download CAD data → www.festo.com

Basic valve, stem actuated valve V/O-3-1/8

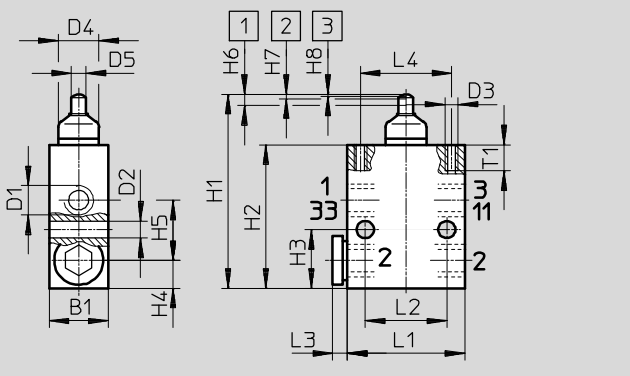

Roller lever AR-01 as actuator attachment for stem actuated valve V/O-3-1/8

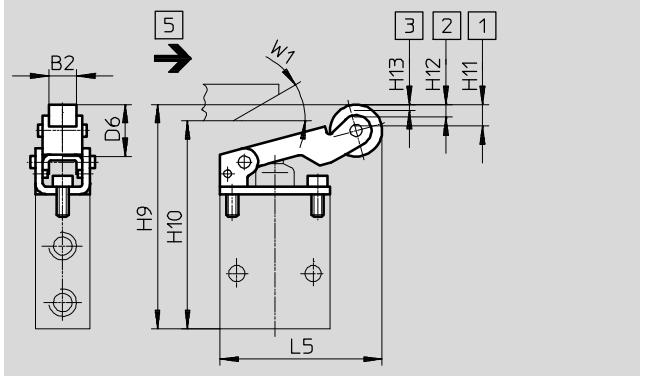

Roller lever with idle return AL-01 as actuator attachment for stem actuated valve V/O-3-1/8

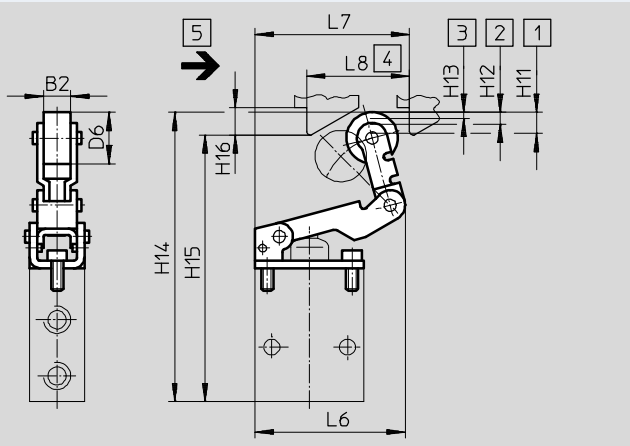

- 1 Max. stroke
- 2 Max. opening
- 3 Start of opening
- 4 Min. actuation stroke
- 5 Actuation direction

Note
 The stem actuated valve V/O-3-1/8 can be extended with an actuator attachment for the roller lever or toggle lever valve. The technical data is listed with the stem actuated valve.

Stem actuated valve	B1	D1	D2	D3	D4	D5	L1	L2	L3	L4	H1	H2	H3	H4	H5	H6	H7 ±0.2	H8 ±0.2	T1
V/O-3-1/8	18	G1/8	5.3	M4	12.5	4.5	36	25	4.5	28	59.5	44	18	8.5	18.5	3.5	1.4	0.6	8

Actuator attachment	B2	D6	L5	L6	L7	L8	H9	H10 min.	H11	H12 +0.2	H13 +0.2	H14	H15 min.	H16	W1
AR-01	8	17	54	-	-	-	71	64	7	4	2	-	-	-	30°
AL-01	8	17	-	50.5	51	34	-	-	7	4	2	93.5	86.5	9	-

Roller lever valves, roller actuated valves

Technical data

Dimensions Download CAD data → www.festo.com

Roller lever valve RS-3-1/8, ROS-3-1/8

1 Initial position
2 ON position
5 Bottom edge of control rail or cam

Roller lever valve RS-4-1/8

1 Initial position
2 ON position
5 Bottom edge of control rail or cam

Roller lever valve	B1	B2	D1	L1	L2	H1	H2	H3 +0.2, -0.3
RS-3-1/8, ROS-3-1/8	7.7	-	12.5	51.5	0.5	64.5	61	6
RS-4-1/8	7.7	9	12.5	51.5	0.5	64.5	61	6

Mounting bracket HV-M5

Mounting bracket HV-1/8

Mounting bracket	B1	B2	B3	D1	L1	L2	H1	H2	H3
HV-M5	17	8	1.5	4.3	20	12	35	4	8
HV-1/8	21	10.5	2	5.3	36	25	42	6	11

Roller lever valves, roller actuated valves

Technical data

Dimensions

Download CAD data → www.festo.com

Roller actuated valve VMEM-DT...32...G18

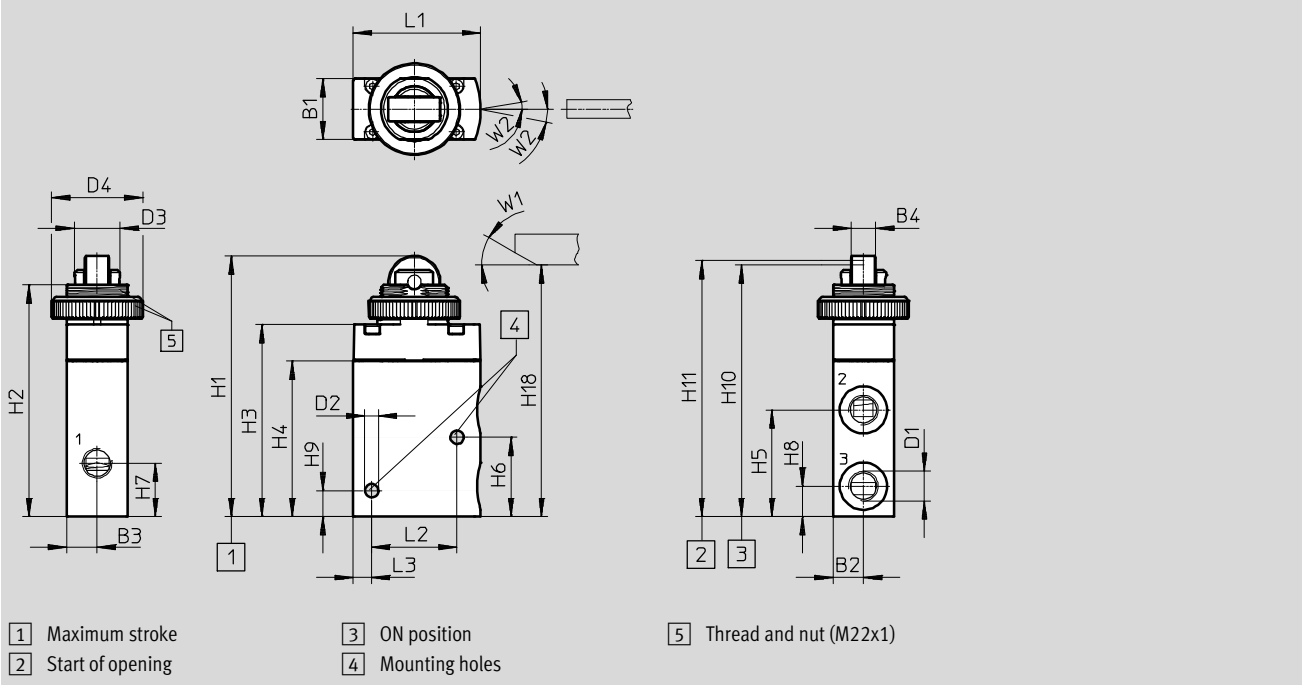

Roller actuated valve	B1	B2	B3	B4	D1	D2	D3	D4	L1	L2	L3	W1	W2
VMEM-DT...32...G18	20	10	10	8	G $\frac{1}{8}$	4.4	15	30	41.7	28	6	30°	5°

Roller actuated valve	H1±0.3	H2	H3	H4	H5	H6	H7	H8	H9	H10±0.4	H11±0.3	H18±0.3
VMEM-DT...32...G18	85.8	76	63	51	35	26	18	10	8.5	82.6	84	82.5

Roller lever valves, roller actuated valves

Technical data

Dimensions Download CAD data → www.festo.com

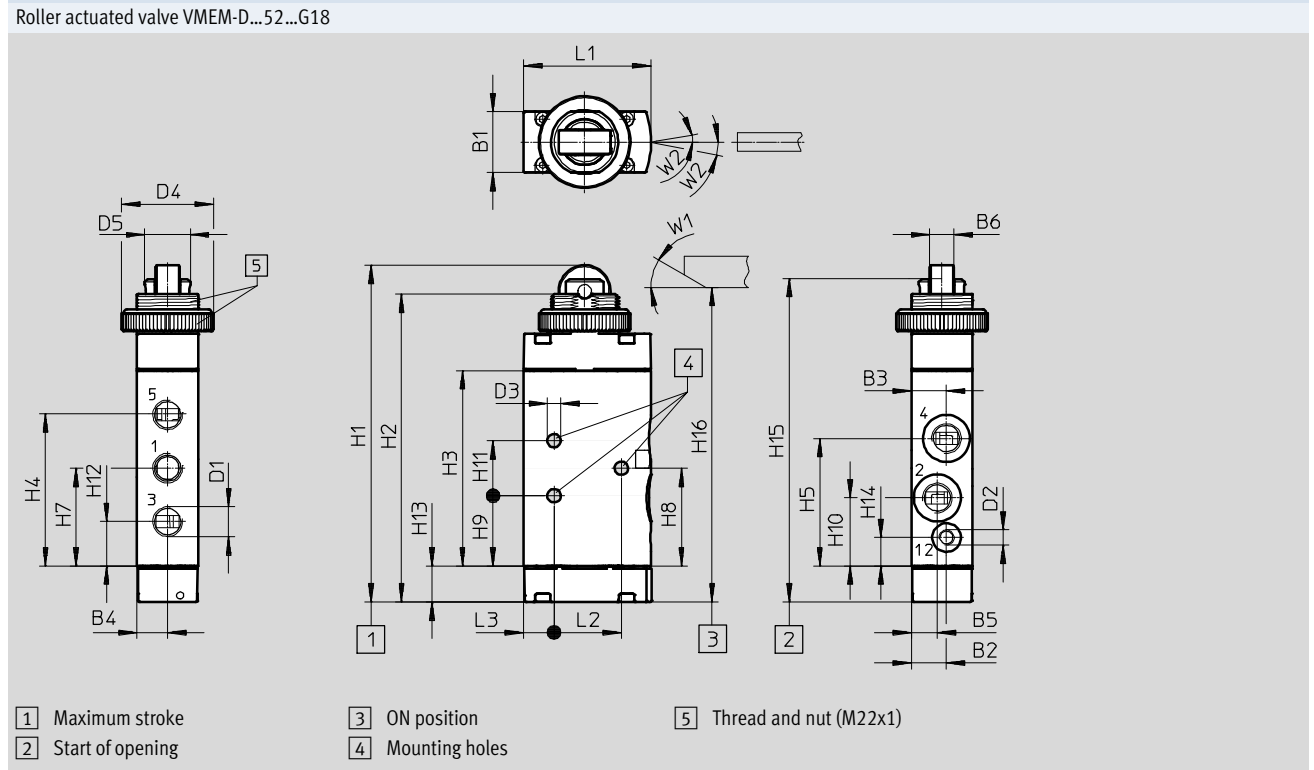



Roller actuated valve	B1	B2	B3	B4	B5	B6	D1	D2	D3	D4	D5	L1	L2	L3	W1	W2
VMEM-D...52...G18	20	11.5	11.5	10	8.5	8	G $\frac{1}{8}$	M5	4.4	30	15	41.7	25	7	30°	5°

Roller actuated valve	H1±0.2	H2	H3	H4	H5	H7	H8	H10	H11	H12	H13	H14	H15±1	H16±0.2
VMEM-D...52...G18	110.6	101.1	64	49.5	41.8	32	32	23	22.3	18	14.5	11.8	106.6	103

Roller lever valves, roller actuated valves

Ordering data



Ordering data						
Nominal flow rate	Valve function	Description	Mechanical reset	Normal position	Part No.	Type
Roller lever valve						
80 l/min	3/2-way valve, monostable	Roller lever valve	■	Open/closed	10748	R/O-3-PK-3
				Closed	3629	R-3-M5
120 l/min	3/2-way valve, monostable	Roller lever valve	■	Closed	2272	RS-3-1/8
				Open	2270	ROS-3-1/8
	4/2-way valve, monostable	Roller lever valve	■	–	2949	RS-4-1/8
550 l/min	5/2-way valve, monostable	Roller lever valve, suitable for vacuum	■	–	8996	R-5-1/4-B
600 l/min	3/2-way valve, monostable	Roller lever valve, suitable for vacuum	■	Closed	8985	R-3-1/4-B
				Open	8991	RO-3-1/4-B
Roller actuated valve						
500 l/min	3/2-way valve, monostable	Roller actuated valve, suitable for vacuum	■	Closed	563386	VMEM-DT-M32C-M-G18
				Open	563387	VMEM-DT-M32U-M-G18
	5/2-way valve, monostable	Roller actuated valve, suitable for vacuum, reverse operation	■	–	563390	VMEM-D-M52-M-G18
				Roller actuated valve	–	563388
	Roller actuated valve, suitable for vacuum, reverse operation	–	–	563389	VMEM-D-M52-E-G18	

Ordering data				
	Description	Part No.	Type	PU ¹⁾
Actuator attachment				
	For stem actuated valve V/O-3-1/8, roller lever	4936	AR-01	1
	For stem actuated valve V/O-3-1/8, roller lever with idle return	4941	AL-01	1
	For roller lever valve R-3-M5, roller lever with mounting screws	6512	AR-05	1

1) Packaging unit

Ball actuated valves

Technical data – Ball actuated valve, standard nominal flow rate 500 l/min

-  Flow rate
500 l/min
 -  Pressure
0.95 ... 10 bar
 -  Temperature range
-10 ... +60 °C
- Mounting either via through-holes or on front panel



General technical data				
Type	VMEM-BTC	VMEM-BTCZ	VMEM-BC	VMEM-BCZ
Standard nominal flow rate [l/min] 1 → 2	500			
Valve function	3/2-way valve		5/2-way valve	
Reset method	Mechanical spring		Mechanical or pneumatic spring	
Design	Disk seat valve, piloted		Piston spool valve, piloted	
Pneumatic connection	G1/8		G1/8	
Pilot air supply	Internal	External	Internal	External
Nominal size [mm]	4.0		4.0	
Weight [g]	148		182	
Max. switching frequency [Hz]	3		3	
Max. actuating speed				
• Axial actuation [m/s]	0.6		0.6	
• Lateral actuation [m/s]	0.2		0.2	
Actuating force [N]	44		44	
Max. actuating force [N]	80		150	
Max. lateral force [N]	30		30	

Materials	
Cover	Anodised wrought aluminium alloy
Seal	NBR
Housing	Anodised wrought aluminium alloy
Note on materials	RoHS-compliant

Operating and environmental conditions				
Type	VMEM-BTC	VMEM-BTCZ	VMEM-BC	VMEM-BCZ
Operating medium	Compressed air to ISO 8573-1:2010 [7:-:-]			
Note on operating/pilot medium	Lubricated operation possible (required during subsequent operation)			
Operating pressure range [bar]				
N/C valves	3.5 ... 8	-0.95 ... 8	-	-
N/O valves	4.5 ... 8	-0.95 ... 8	2.5 ... 10 ²⁾	-0.95 ... 10 ¹⁾
Pilot pressure [bar]				
N/C valves	-	3.5 ... 8	-	-
N/O valves	-	4.5 ... 8	-	2.5 ... 10
Temperature of medium [°C]	-10 ... +60			
Ambient temperature [°C]	-10 ... +60			
Corrosion resistance class CRC ³⁾	2			

1) Suitable for vacuum, mechanical spring or external pneumatic spring reset method (in the type codes Reset method M: Mechanical spring or E: External pneumatic spring)
 2) Not suitable for vacuum, internal pneumatic spring reset method (in the type codes Reset method A: Internal pneumatic spring)
 3) Corrosion resistance class CRC 2 to Festo standard FN 940070
 Moderate corrosion stress. Indoor applications in which condensation may occur. External visible parts with primarily decorative requirements for the surface and which are in direct contact with the ambient atmosphere typical for industrial applications.

Ball actuated valves

Technical data

Dimensions

Download CAD data → www.festo.com

Ball actuated valve VMEM-BTC...32...G18

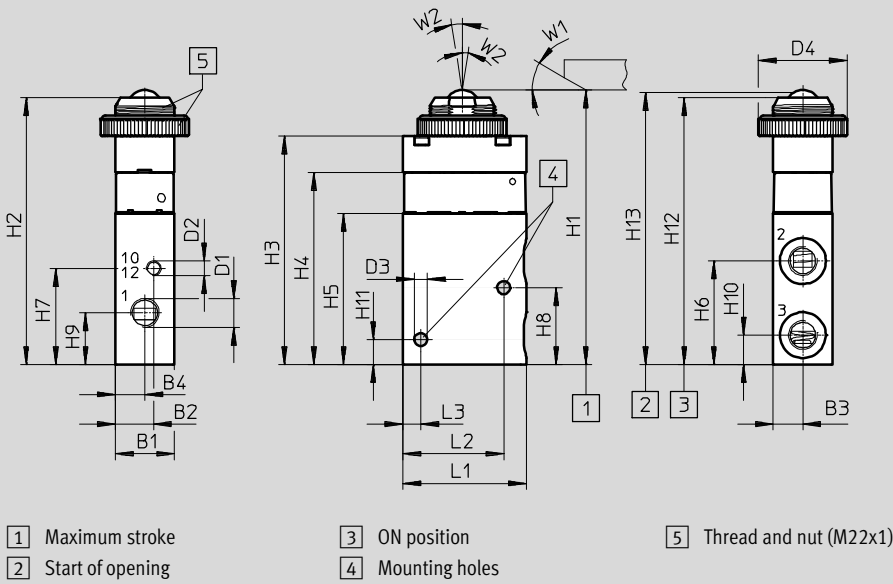

Ball actuated valve	B1	B2	B3	B4	D1	D2	D3	D4	L1	L2	L3	W1	W2
VMEM-BTC...32...G18	20	13	10	10	G $\frac{1}{8}$	M5	4.4	30	41.7	28	6	30°	2°

Ball actuated valve	H1±0.3	H2	H3	H4	H5	H6	H7	H8	H9	H10	H11	H12±0.4	H13±0.3
VMEM-BTC...32...G18	92.8	90.1	77.1	64.8	51	35	32.5	26	17.5	10	8.5	90	91

Ball actuated valve VMEM-BC/BCZ...52...G18

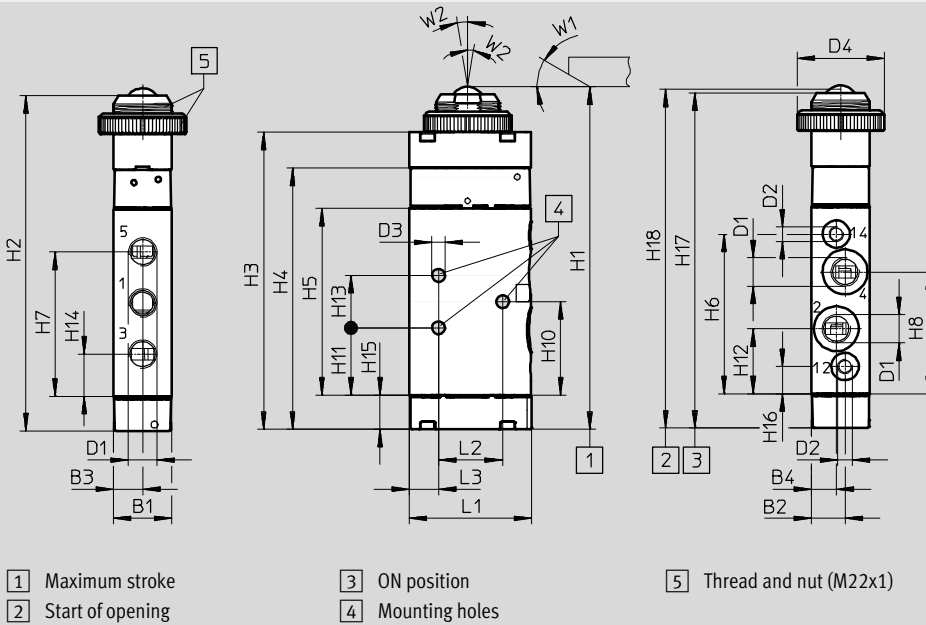

Ball actuated valve	B1	B2	B3	B4	D1	D2	D3	D4	L1	L2	L3	H1±0.2	H2	H3	H4
VMEM-BC/BCZ...52...G18	20	11.5	10	8.5	G $\frac{1}{8}$	M5	4.4	30	41.7	25	7	117.3	114.9	101.9	89.6

Ball actuated valve	H5	H6	H7	H8	H9	H10	H11	H12	H13	H14	H15	H16	H17±0.2	H18±0.2	W1	W2
VMEM-BC/BCZ...52...G18	64	54.7	49.5	41.8	32	32	23	22.3	18	14.5	11.8	9.3	115	115.7	30°	2°

Ball actuated valves

Ordering data

Ordering data							
Nominal flow rate	Valve function	Description	Mechanical reset	Normal position	Pilot air ¹⁾	Part No.	Type
Ball actuated valve							
500 l/min	3/2-way valve, monostable	Ball actuated valve	■	Closed	Internal	563772	VMEM-BTC-M32C-M-G18
		Ball actuated valve, suitable for vacuum		Closed	External	563773	VMEM-BTCZ-M32C-M-G18
		Ball actuated valve	■	Open	Internal	563774	VMEM-BTC-M32U-M-G18
		Ball actuated valve, suitable for vacuum		Open	External	563775	VMEM-BTCZ-M32U-M-G18
	5/2-way valve, monostable	Ball actuated valve	■	-	Internal	563776	VMEM-BC-M52-M-G18
		Ball actuated valve, suitable for vacuum, reverse operation		-	External	563779	VMEM-BCZ-M52-M-G18
		Ball actuated valve	-	-	Internal	563778	VMEM-BC-M52-A-G18
		Ball actuated valve, suitable for vacuum, reverse operation		-	External	563780	VMEM-BCZ-M52-E-G18

1) With piloted valves

Valves, mechanically actuated

Accessories

FESTO

Ordering data					
	Description		Part No.	Type	PU ¹⁾
Push-in fitting with external hex (Mini version)					
	Connecting thread M5 for tubing O.D.	3 mm	153302	QSM-M5-3	10
		4 mm	153304	QSM-M5-4	10
		6 mm	153306	QSM-M5-6	10
	Connecting thread G $\frac{1}{8}$ for tubing O.D.	4 mm	186264	QSM-G$\frac{1}{8}$-4	10
		6 mm	186265	QSM-G$\frac{1}{8}$-6	10
Push-in fitting with external hex (Standard version)					
	Connecting thread G $\frac{1}{8}$ for tubing O.D.	4 mm	186095	QS-G$\frac{1}{8}$-4	10
		6 mm	186096	QS-G$\frac{1}{8}$-6	10
	Connecting thread G $\frac{1}{4}$ for tubing O.D.	6 mm	186097	QS-G$\frac{1}{4}$-6	10
		8 mm	186099	QS-G$\frac{1}{4}$-8	10
		10 mm	186101	QS-G$\frac{1}{4}$-10	10
Push-in fitting with internal hex (Mini version)					
	Connecting thread M5 for tubing O.D.	3 mm	153313	QSM-M5-3-I	10
		4 mm	153315	QSM-M5-4-I	10
		6 mm	153315	QSM-M5-6-I	10
	Connecting thread G $\frac{1}{8}$ for tubing O.D.	4 mm	186266	QSM-G$\frac{1}{8}$-4-I	10
		6 mm	186267	QSM-G$\frac{1}{8}$-6-I	10
Push-in fitting with internal hex (Standard version)					
	Connecting thread G $\frac{1}{8}$ for tubing O.D.	4 mm	186106	QS-G$\frac{1}{8}$-4-I	10
		6 mm	186107	QS-G$\frac{1}{8}$-6-I	10
		8 mm	186109	QS-G$\frac{1}{8}$-8-I	10
	Connecting thread G $\frac{1}{4}$ for tubing O.D.	6 mm	186108	QS-G$\frac{1}{4}$-6-I	10
		8 mm	186110	QS-G$\frac{1}{4}$-8-I	10
		10 mm	186112	QS-G$\frac{1}{4}$-10-I	10
Silencer					
	Connecting thread	G $\frac{1}{8}$	2307	U-$\frac{1}{8}$	1
			161419	UC-$\frac{1}{8}$	1
		G $\frac{1}{4}$	2316	U-$\frac{1}{4}$	1
			6842	U-$\frac{1}{4}$-B	1
			165004	UC-$\frac{1}{4}$	1
Mounting bracket					
	For valves with push-in connector and threaded connection M5	11 g	9634	HV-M5	1
	For valves with push-in connector and threaded connection G $\frac{1}{8}$	32 g	9635	HV-$\frac{1}{8}$	1

1) Packaging unit

Product Range and Company Overview

A Complete Suite and Company Overview

Our experienced engineers provide complete support at every stage of your development process, including: conceptualization, analysis, engineering, design, assembly, documentation, validation, and production.



Custom Automation Components
Complete custom engineered solutions



Custom Control Cabinets
Comprehensive engineering support and on-site services



Complete Systems
Shipment, stocking and storage services

The Broadest Range of Automation Components

With a comprehensive line of more than 30,000 automation components, Festo is capable of solving the most complex automation requirements.



Electromechanical
Electromechanical actuators, motors, controllers & drivers



Pneumatics
Pneumatic linear and rotary actuators, valves, and air supply



PLCs and I/O Devices
PLC's, operator interfaces, sensors and I/O devices

Supporting Advanced Automation... As No One Else Can!

Festo is a leading global manufacturer of pneumatic and electromechanical systems, components and controls for industrial automation, with more than 16,000 employees in 60 national headquarters serving more than 180 countries. For more than 80 years, Festo has continuously elevated the state of manufacturing with innovations and optimized motion control solutions that deliver higher performing, more profitable automated manufacturing and processing equipment. Our dedication to the advancement of automation extends beyond technology to the education and development of current and future automation and robotics designers with simulation tools, teaching programs, and on-site services.

Quality Assurance, ISO 9001 and ISO 14001 Certifications

Festo Corporation is committed to supply all Festo products and services that will meet or exceed our customers' requirements in product quality, delivery, customer service and satisfaction.

To meet this commitment, we strive to ensure a consistent, integrated, and systematic approach to management that will meet or exceed the requirements of the ISO 9001 standard for Quality Management and the ISO 14001 standard for Environmental Management.



© Copyright 2013, Festo Corporation. While every effort is made to ensure that all dimensions and specifications are correct, Festo cannot guarantee that publications are completely free of any error, in particular typing or printing errors. Accordingly, Festo cannot be held responsible for the same. For Liability and Warranty conditions, refer to our "Terms and Conditions of Sale", available from your local Festo office. All rights reserved. No part of this publication may be reproduced, distributed, or transmitted in any form or by any means, electronic, mechanical, photocopying or otherwise, without the prior written permission of Festo. All technical data subject to change according to technical update.



Printed on recycled paper at New Horizon Graphic, Inc., FSC certified as an environmental friendly printing plant.

Festo North America

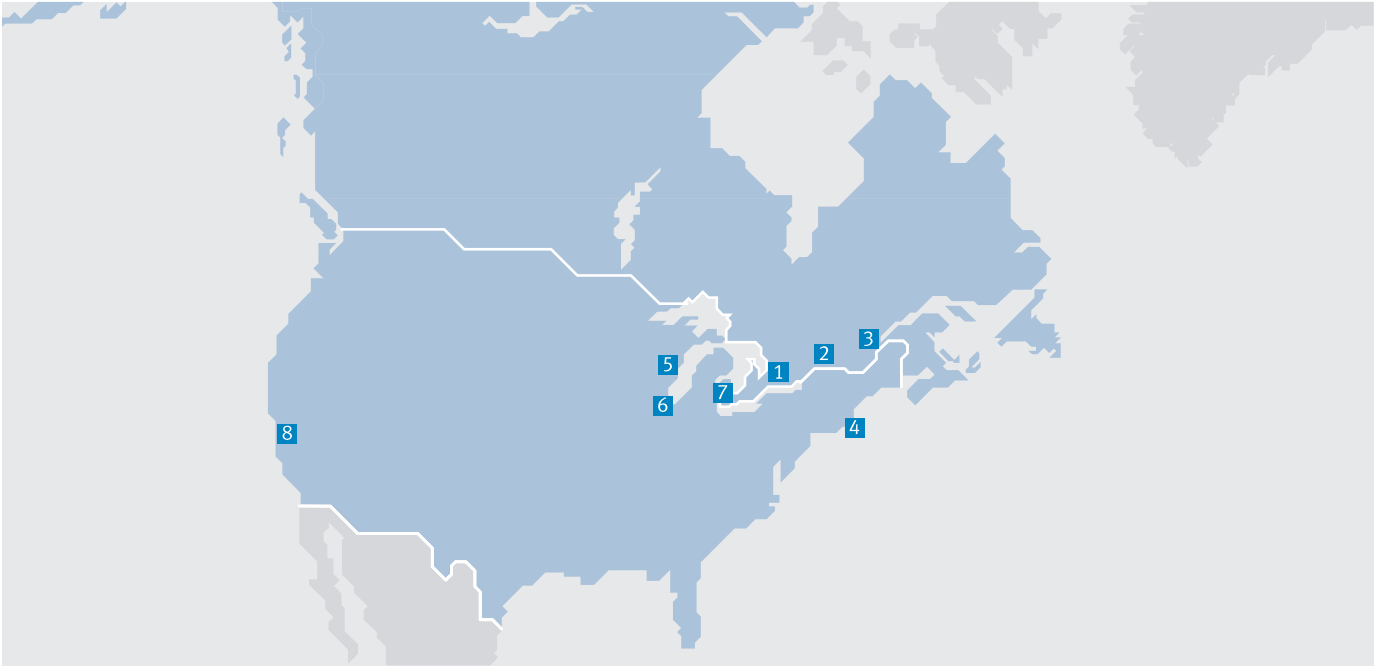

**1 Festo Canada
Headquarters
Festo Inc.**
5300 Explorer Drive
Mississauga, ON
L4W 5G4

2 Montréal
5600, Trans-Canada
Pointe-Claire, QC
H9R 1B6

3 Québec City
2930, rue Watt#117
Québec, QC
G1X 4G3



**4 Festo United States
Headquarters
Festo Corporation**
395 Moreland Road
Hauppauge, NY
11788

5 Appleton
North 922 Tower View Drive, Suite N
Greenville, WI
54942

7 Detroit
1441 West Long Lake Road
Troy, MI
48098

6 Chicago
85 W Algonquin - Suite 340
Arlington Heights, IL
60005

8 Silicon Valley
4935 Southfront Road, Suite F
Livermore, CA
94550

Festo Regional Contact Center

Canadian Customers

Commercial Support:
Tel: 1 877 GO FESTO (1 877 463 3786)
Fax: 1 877 FX FESTO (1 877 393 3786)
Email: festo.canada@ca.festo.com

Technical Support:
Tel: 1 866 GO FESTO (1 866 463 3786)
Fax: 1 877 FX FESTO (1 877 393 3786)
Email: technical.support@ca.festo.com

USA Customers

Commercial Support:
Tel: 1 800 99 FESTO (1 800 993 3786)
Fax: 1 800 96 FESTO (1 800 963 3786)
Email: customer.service@us.festo.com

Technical Support:
Tel: 1 866 GO FESTO (1 866 463 3786)
Fax: 1 800 96 FESTO (1 800 963 3786)
Email: product.support@us.festo.com