

Valves, manually operated

FESTO



Valves, manually operated

Key features

FESTO

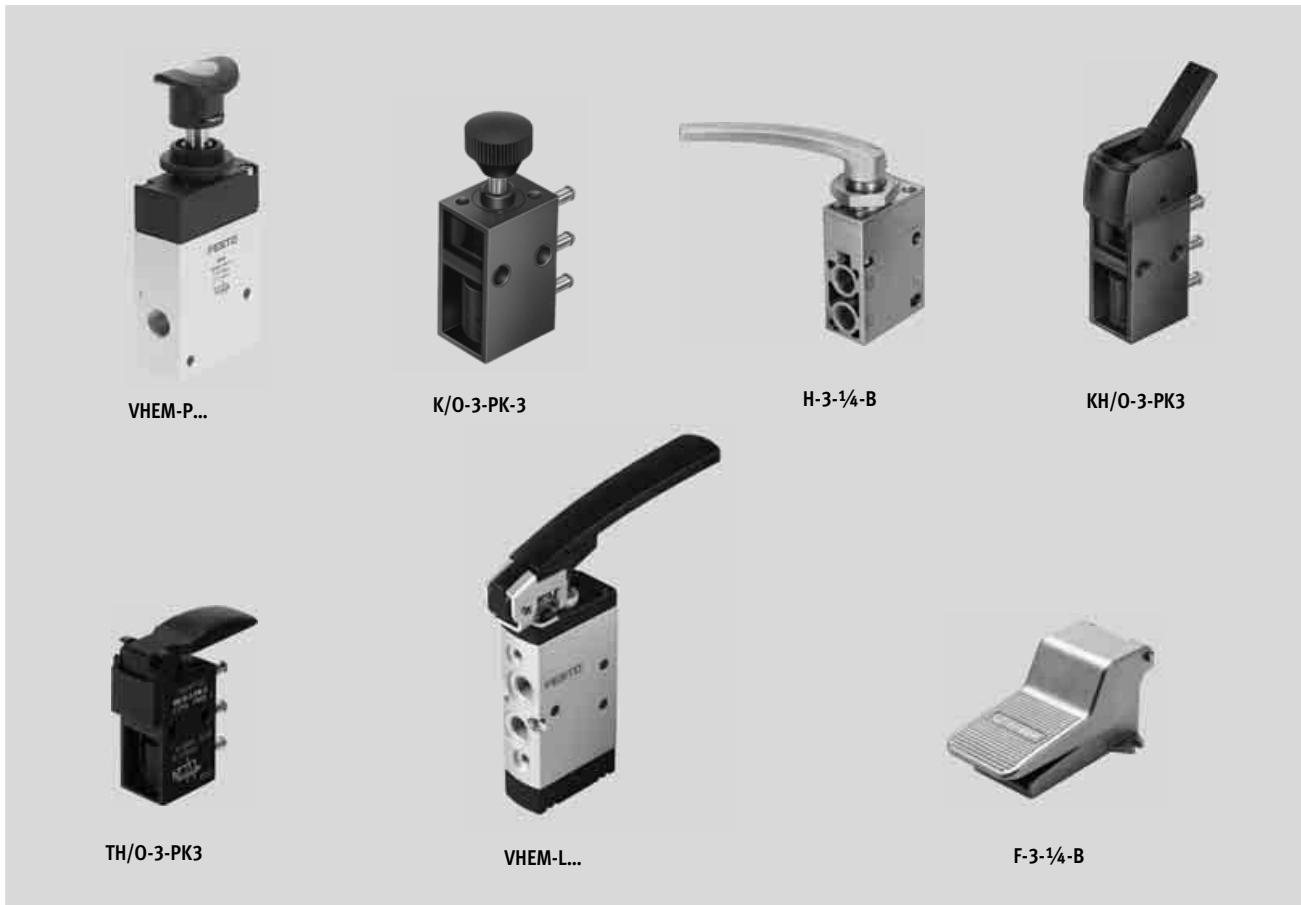

VHEM-P...

K/O-3-PK-3

H-3-1/4-B

KH/O-3-PK3

TH/O-3-PK3

VHEM-L...

F-3-1/4-B

Innovative

- Small and compact for a wide range of pneumatic applications
- Numerous selectable valve functions: 3/2-way and 5/2-way functions
- With flow rates of up to 1,000 l/min, valves VHEM offer outstanding pneumatic performance for a wide range of applications
- Low weight
- Minimal actuating forces

Versatile

- Flexibility of the pneumatic working lines provides a practical solution to different requirements
- Round silencer for ducted exhaust air
- Suitable for vacuum in some cases
- Reverse operation possible in some cases
- Actuation: direct and piloted
- Pressure range from vacuum to 10 bar possible
- Design:
 - Pushbutton valve
 - Toggle lever valve
 - Hand lever valve
 - Finger lever valve
 - Foot valve

Reliable

- Durable thanks to proven piston spool and piston poppet valves
- Sturdy thanks to metal or plastic housing and connecting thread or connector

Easy to mount

- Front panel mounting or mounting on bracket

Valves, manually operated

Key features

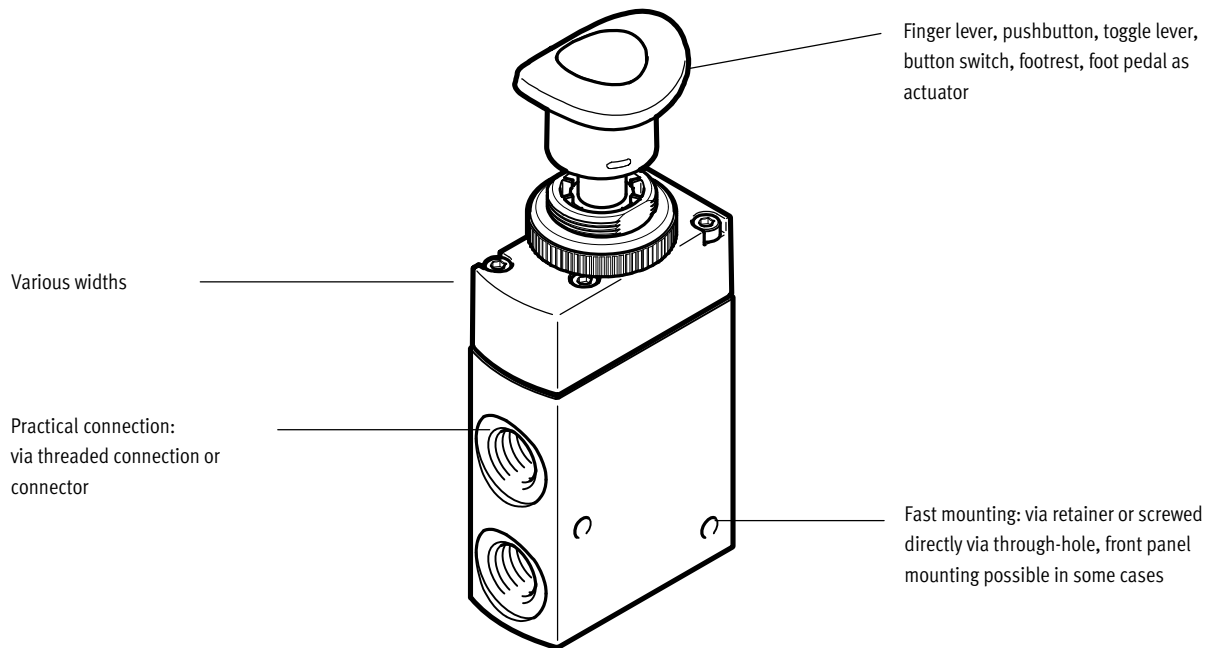

Equipment options

3/2-way valve

- Normally open/closed
- Mechanical spring
- Vacuum operation possible
- Pneumatically piloted or directly actuated
- Ducted exhaust air
- Detenting (bistable) or non-detenting (monostable)

5/2-way valve

- Pneumatic spring/mechanical spring
- Vacuum operation possible
- Reversible
- Pneumatically piloted or directly actuated
- Ducted exhaust air
- Detenting (bistable) or non-detenting (monostable)

Valve selection

→ Internet: www.festo.com

You order mechanically and manually operated valves using the order code:

Ordering system for valves
 → Internet: mechanically and manually operated directional control valves

Valves, manually operated

Peripherals overview

FESTO

Manually operated valves

Finger lever valve VHEM-L, 5/2-way

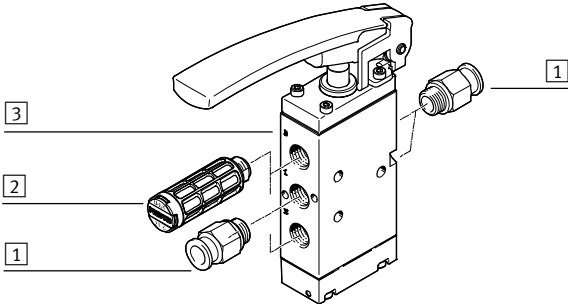

Pushbutton valve VHEM-P..., 3/2-way

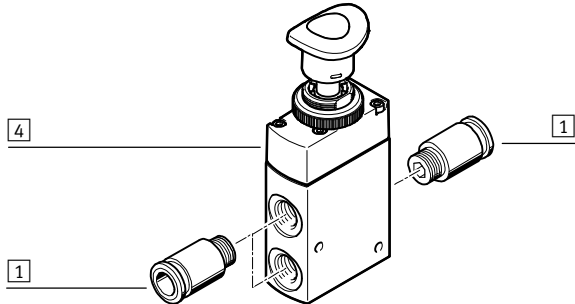

	Brief description	→ Page/Internet
1	Fitting	For supply air/exhaust ports (1, 3, 5) and working lines (2, 4)
2	Silencer	For exhaust ports (3, 5)
3	Finger lever valve	VHEM-L...
4	Pushbutton valve	VHEM-P...

Manually operated valves

Foot valve F-3_M5 ..., 3/2-way

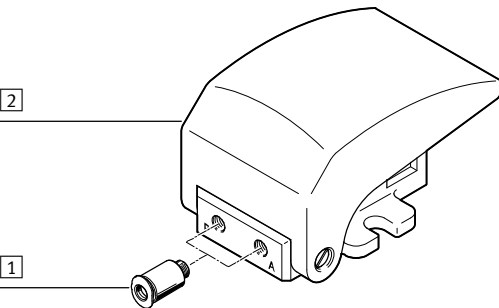

Toggle lever valve KH/O-3-PK, 3/2-way

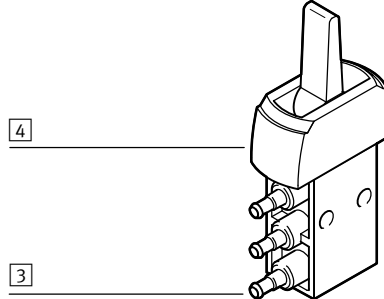

	Brief description	→ Page/Internet
1	Fitting	For supply air/exhaust ports (1, 3, 5) and working lines (2, 4)
2	Foot valve	F- ...
3	Tubing connector	For standard I.D. tubing
4	Toggle lever valve	KH/O-3-PK

Valves, manually operated

Key features

Manually operated valves

Manually operated valves are used in all industrial sectors, as well as in the commercial trades. They are used to

carry out simple processes such as clamping or closing safety doors. Depending on the desired actuation

(pushing, rotating/swivelling or tilting), the valves are either detenting or non-detenting. The valves are directly

controlled in some cases or are pneumatically piloted.

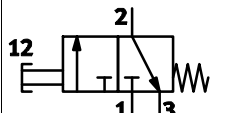
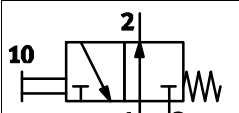
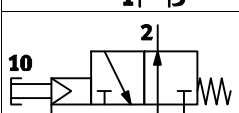
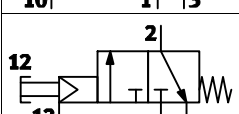
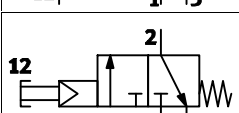
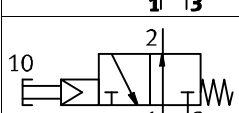
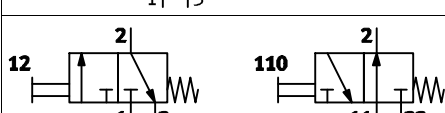
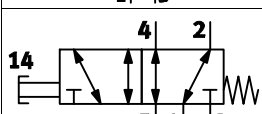
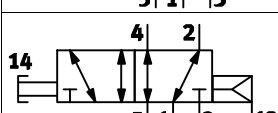
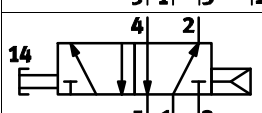
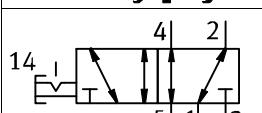
Valve functions		
Circuit symbol	Type	Description
Pushbutton valve		
	VHEM-LT-M32C K-3-M5	3/2-way valve, monostable <ul style="list-style-type: none"> • Normally closed • Mechanical spring return • Suitable for vacuum
	VHEM-LT-M32U	3/2-way valve, monostable <ul style="list-style-type: none"> • Normally open • Mechanical spring return • Suitable for vacuum
	VHEM-PTCZ-M32U	3/2-way valve, monostable <ul style="list-style-type: none"> • Normally open • Mechanical spring return • Pneumatically piloted
	VHEM-PTCZ-M32C	3/2-way valve, monostable <ul style="list-style-type: none"> • Normally closed • Mechanical spring return • Pneumatically piloted
	VHEM-PTC-M32C	3/2-way valve, monostable <ul style="list-style-type: none"> • Normally closed • Pneumatically piloted • Mechanical spring return
	VHEM-PTC-M32U	3/2-way valve, monostable <ul style="list-style-type: none"> • Normally open • Pneumatically piloted • Mechanical spring return
	K/O-3-PK-3	3/2-way valve, monostable <ul style="list-style-type: none"> • Normally open/closed • Mechanical spring return
	VHEM-P-M52-M	5/2-way valve, monostable <ul style="list-style-type: none"> • Reverse operation possible • Mechanical spring return • Suitable for vacuum
	VHEM-P-M52-E VHEM-L-M52-E	5/2-way valve, monostable <ul style="list-style-type: none"> • Reverse operation possible • (External) pneumatic spring return • Suitable for vacuum
	VHEM-P-M52-A VHEM-L-M52-A	5/2-way valve, monostable <ul style="list-style-type: none"> • Reverse operation not possible • (Internal) pneumatic spring return
	VHEM-PA-B52	5/2-way valve, bistable <ul style="list-style-type: none"> • Detenting actuation • Reverse operation possible • Suitable for vacuum

Valves, manually operated

Key features

Valve functions		
Circuit symbol	Type	Description
Toggle lever valve		
	KH/O-3-PK-3	3/2-way valve, monostable <ul style="list-style-type: none"> • Detenting actuation • Normally open/closed • Mechanical spring return
Finger lever valve		
	TH/O-3-PK-3	3/2-way valve, monostable <ul style="list-style-type: none"> • Normally open/closed • Mechanical spring return
	TH-3-M5	3/2-way valve, monostable <ul style="list-style-type: none"> • Normally closed • Mechanical spring return • Suitable for vacuum
	TH-3-1/4-B	3/2-way valve, monostable <ul style="list-style-type: none"> • Normally closed • Mechanical spring return
	THO-3-1/4-B	3/2-way valve, monostable <ul style="list-style-type: none"> • Normally open • Mechanical spring return
	VHEM-L-M52-M TH-5-1/4-B	5/2-way valve, monostable <ul style="list-style-type: none"> • Mechanical spring return • Suitable for vacuum

Valves, manually operated

Key features

Valve functions		
Circuit symbol	Type	Description
Hand lever valve		
12 	H-3-1/4-B	3/2-way valve, bistable <ul style="list-style-type: none"> • Detenting actuation
14 	H-5-1/4-B	5/2-way valve, bistable <ul style="list-style-type: none"> • Detenting actuation
Foot valve, foot valve with detent		
12 	F-3-1/4-B	3/2-way valve, monostable <ul style="list-style-type: none"> • Normally closed • Mechanical spring return
10 	F-3-1/4-B	3/2-way valve, monostable <ul style="list-style-type: none"> • Normally open • Mechanical spring return
12 	FP-3-1/4-B FPB-3-1/4	3/2-way valve, monostable <ul style="list-style-type: none"> • Detenting actuation • Normally closed • Mechanical spring return
14 	F-5-1/4-B	5/2-way valve, monostable <ul style="list-style-type: none"> • Mechanical spring return
14 	FP-5-1/4-B	5/2-way valve, monostable <ul style="list-style-type: none"> • Detenting actuation
14 	FPB-5-1/4	5/2-way valve, monostable <ul style="list-style-type: none"> • Detenting actuation • Mechanical spring return

-  - Note

A filter must be installed upstream of valves operated in vacuum mode. This prevents any foreign matter in the intake air getting into the valve (e.g. when operating a suction cup).

Valves, manually operated

Type codes

FESTO

VHEM - PTCZ - M32C - M - G14

Valve series	
VHEM	Manually operated valves

Design	
Actuation	
L	Finger lever valve
P	Pushbutton valve
Design principle	
-	Piston spool
T	Disk seat
Actuation	
-	Directly actuated
C	Pneumatically piloted
Pilot air supply	
-	Internal
Z	External
Switching function	
-	Monostable valve
A	Active (spring, bistable valve)
X	Passive (air, bistable valve)

Valve functions	
M32C	3/2-way valve, monostable, normally closed
M32U	3/2-way valve, monostable, normally open
B32	3/2-way valve, bistable
M52	5/2-way valve, monostable
B52	5/2-way valve, bistable

Reset method	
-	None
A	Internal pneumatic spring
E	External pneumatic spring
M	Mechanical spring

Pneumatic connection	
G14	Thread G1/4
G18	Thread G1/8

Pushbutton valves

Technical data – Pushbutton valve, standard nominal flow rate 80 l/min

-  - Flow rate
80 ... 1,000 l/min

-  - Pressure
-0.95 ... 10 bar

-  - Temperature range
-10 ... +60 °C

Mounting either via through-hole or on front panel (in the case of F-3-M5 with flange eyes)



General technical data				
Type		K/O-3-PK-3	K-3-M5	F-3-M5
Standard nominal flow rate [l/min]	1 → 2	80		
Valve function		3/2-way valve		
Design		Disk seat valve, directly actuated		
Pneumatic connection		PK-3 ¹⁾	M5	M5
Nominal size [mm]		2.5	2.0	2.0
Weight [g]		20	28	165
Actuating force [N]		-	23.0	7.0
• at 6 bar				
• with normally closed position	[N]	24.0	-	-
• with normally open position	[N]	17.0	-	-

1) PK-3=Barbed fitting for plastic tubing with 3 mm nominal diameter

Materials				
Type		K/O-3-PK-3	K-3-M5	F-3-M5
Seal		NBR		-
Housing		Plastic	Die-cast zinc	Die-cast zinc

Operating and environmental conditions				
Type		K/O-3-PK-3	K-3-M5	F-3-M5
Operating medium		Compressed air according to ISO 8573-1:2010 [7:-:-]		
Note about the operating/pilot medium		Lubricated operation possible (required during subsequent operation)		
Operating pressure range [bar]		0 ... 8	-0.95 ... 8	-0.95 ... 8
Ambient temperature [°C]		-10 ... +60		

Pushbutton valves

Technical data – Pushbutton valve, standard nominal flow rate 500 l/min

General technical data				
Type	VHEM-PTC ... G18	VHEM-PA-B52-G18	VHEM-P ... G18	
Standard nominal flow rate [l/min] 1 → 2	500			
Valve function	3/2-way valve	5/2-way valve, bistable	5/2-way valve, monostable	
Reset method	Mechanical spring	–	Mechanical or pneumatic spring	
Design	Disk seat valve, piloted	Piston spool valve, directly actuated		
Pneumatic connection	G $\frac{1}{8}$	G $\frac{1}{8}$		
Pilot air supply	Internal or external	–		
Nominal size [mm]	4.0	4.0		
Weight [g]	198	194		
Actuating force [N]	28.0	17.0	26.0 ¹⁾ 39.0	
Unlocking force [N]	–	48.0	–	

1) Valve 26.0 with mechanical spring reset method, value 39.0 with pneumatic spring reset method

Materials	
Seal	NBR
Housing	Anodised wrought aluminium alloy
Note on materials	RoHS-compliant

Operating and environmental conditions				
Type	VHEM-PTC ... G18	VHEM-PA-B52-G18	VHEM-P ... G18	
Operating medium	Compressed air to ISO 8573-1:2010 [7:-:-]			
Note about the operating/ pilot medium	Lubricated operation possible (required during subsequent operation)			
Operating pressure range [bar]				
N/C valves	3.5 ... 8	–	–	
N/O valves	4.5 ... 8	–0.95 ... 10 ¹⁾	–0.95 ... 10 ¹⁾	2.5 ... 10 ²⁾
Temperature of medium [°C]	–10 ... +60			
Ambient temperature [°C]	–10 ... +60			

1) Suitable for vacuum, mechanical spring or external pneumatic spring reset method (in the type codes Reset method M: Mechanical spring or E: External pneumatic spring)

2) Not suitable for vacuum, internal pneumatic spring reset method (in the type codes Reset method A: Internal pneumatic spring)

Safety characteristics for bistable valves VHEM-PA-B52 ...	
Shock resistance	Shock test with severity level 1 ¹⁾ , to EN 60068-2-27
Vibration resistance	Transport application test with severity level 1 ¹⁾ , to EN 60068-2-6

1) See following test conditions table for explanations of the severity levels.

Test conditions		
Severity level	Vibration	Shock
Severity level 1	0.15 mm travel at 10 ... 58 Hz, 2 g acceleration at 58 ... 150 Hz	±15 g at 11 ms duration, 5 shocks per direction
Severity level 2	0.35 mm travel at 10 ... 60 Hz, 5 g acceleration at 60 ... 150 Hz	±30 g at 11 ms duration, 5 shocks per direction

Pushbutton valves

Technical data – Pushbutton valve, standard nominal flow rate 1,000 l/min

General technical data		
Type	VHEM-P ... G14	VHEM-PA-B52-G14
Standard nominal flow rate [l/min] 1 → 2	1,000	
Valve function	5/2-way valve	5/2-way valve, bistable
Reset method	Mechanical or pneumatic spring	–
Design	Piston spool valve, directly actuated	Piston spool valve, directly actuated
Pneumatic connection	G $\frac{1}{4}$	G $\frac{1}{4}$
Pilot air supply	–	–
Nominal size [mm]	6.0	6.0
Weight [g]	366	366
Actuating force [N]	39.0	22.0
Unlocking force [N]	–	51.0

Materials	
Seal	NBR
Housing	Anodised wrought aluminium alloy
Note on materials	RoHS-compliant

Operating and environmental conditions			
Type	VHEM-P ... G14	VHEM-PA-B52-G14	
Operating medium	Compressed air to ISO 8573-1:2010 [7:--:--]		
Note about the operating/ pilot medium	Lubricated operation possible (required during subsequent operation)		
Operating pressure range [bar]	–0.95 ... 10 ¹⁾	2.5 ... 10 ²⁾	–0.95 ... 10
Temperature of medium [°C]	–10 ... +60		
Ambient temperature [°C]	–10 ... +60		

- 1) Suitable for vacuum, mechanical spring or external pneumatic spring reset method (in the type codes Reset method M: Mechanical spring or E: External pneumatic spring)
 2) Not suitable for vacuum, internal pneumatic spring reset method (in the type codes Reset method A: Internal pneumatic spring)

Safety characteristics for bistable valves VHEM-PA-B52 ...	
Shock resistance	Shock test with severity level 1 ¹⁾ , to EN 60068-2-27
Vibration resistance	Transport application test with severity level 1 ¹⁾ , to EN 60068-2-6

- 1) See following test conditions table for explanations of the severity levels.

Test conditions		
Severity level	Vibration	Shock
Severity level 1	0.15 mm travel at 10 ... 58 Hz, 2 g acceleration at 58 ... 150 Hz	±15 g at 11 ms duration, 5 shocks per direction
Severity level 2	0.35 mm travel at 10 ... 60 Hz, 5 g acceleration at 60 ... 150 Hz	±30 g at 11 ms duration, 5 shocks per direction

Pushbutton valves

Technical data – Pushbutton valve

Dimensions

Download CAD data → www.festo.com

Pushbutton valve K/O-3-PK-3

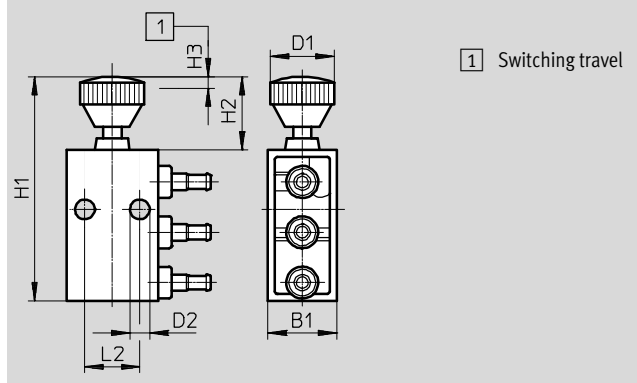

Pushbutton valve K-3-M5

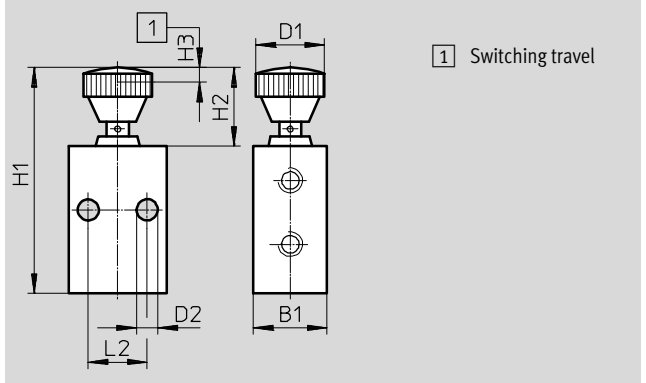

Pushbutton valve	B1	D1	D2	H1	H2	H3	L2
K/O-3-PK-3	15	14	4.3	49	16	2.5	12
K-3-M5	15	14	4.3	46	16	3	12

Pushbutton valve F-3-M5

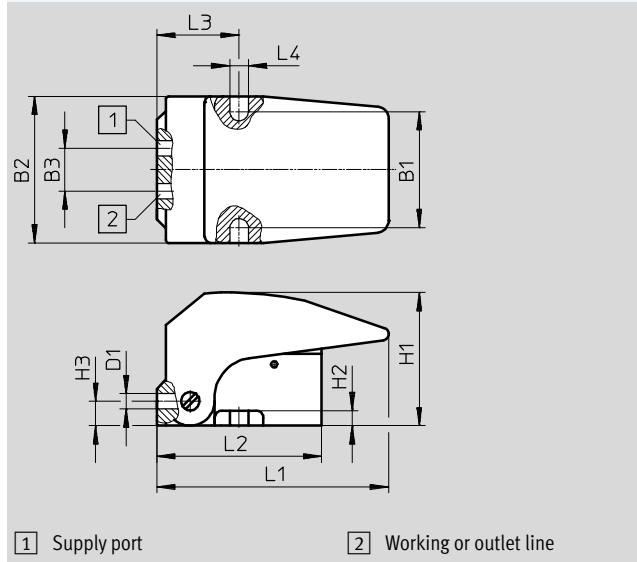

Mounting bracket HV-M5

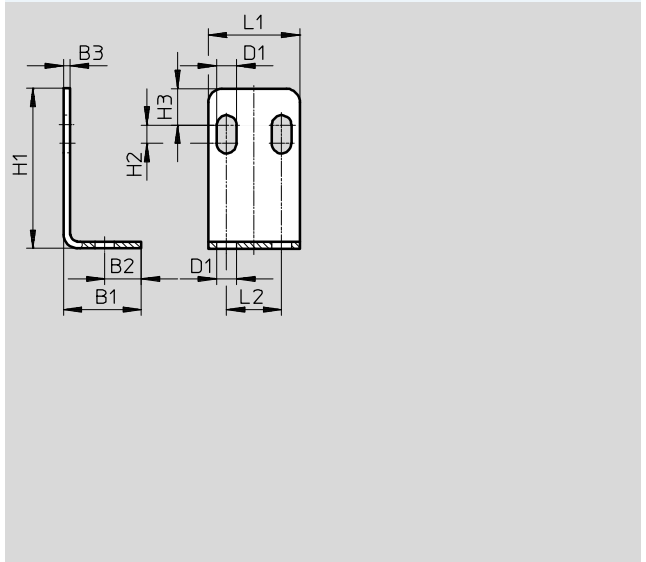

	B1	B2	B3	D1	H1	H2	H3	L1	L2	L3	L4
Pushbutton valve F-3-M5	38	48	15	M5	43	5	7.5	76.5	54	27	6.5
Mounting bracket HV-M5	17	8	1.5	4.3	35	4	8	20	12	-	-

Pushbutton valves

Technical data – Pushbutton valve

Dimensions

Download CAD data → www.festo.com

Pushbutton valve VHEM-PTC ... 32 ... G ...

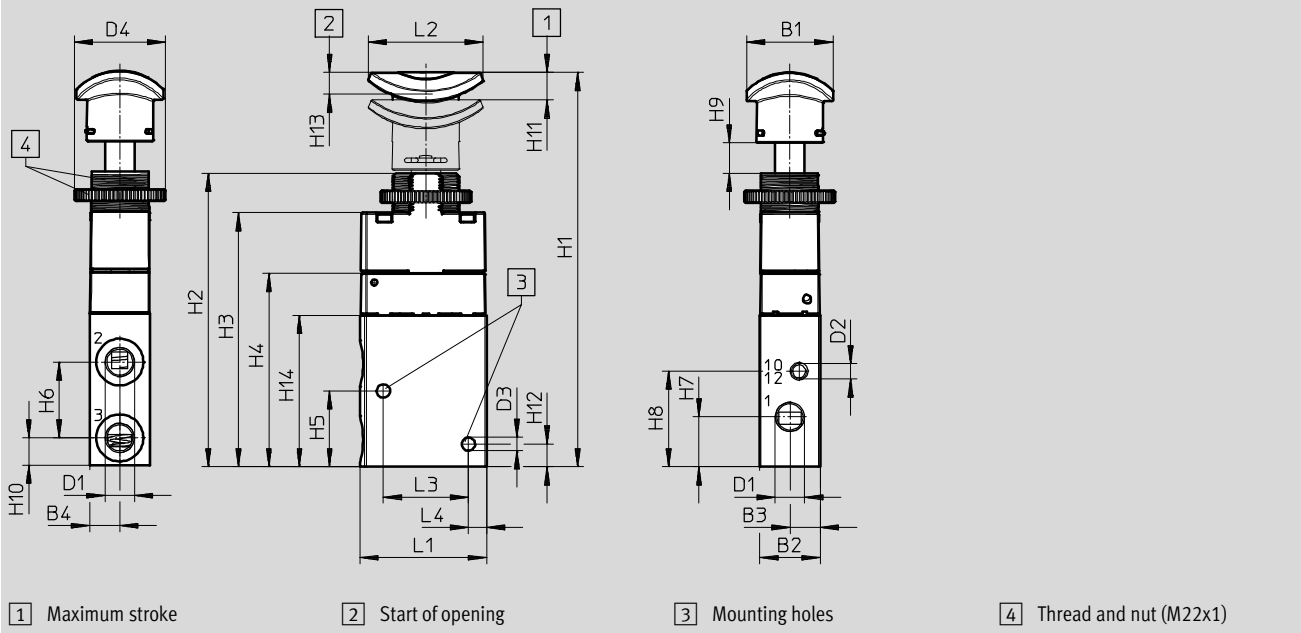

Pushbutton valve	B1	B2	B3	B4	D1	D2	D3	D4	L1	L2	L3	L4
VHEM-PTC...32...G18	28.5	20	10	10	G $\frac{1}{8}$	M5	4.4	30	41.7	37.8	28	6

Pushbutton valve	H1	H2	H3	H4	H5	H6	H7	H8	H9	H10	H11	H12	H13	H14
VHEM-PTC...32...G18	130	96.8	83.8	63.8	26	25	16.5	31.5	10	9	9	8.5	7.2	50

Pushbutton valves

Technical data – Pushbutton valve

Dimensions

Download CAD data → www.festo.com

Pushbutton valve VHEM-P- ... 52 ... G ..., VHEM-PA-B52-G ...

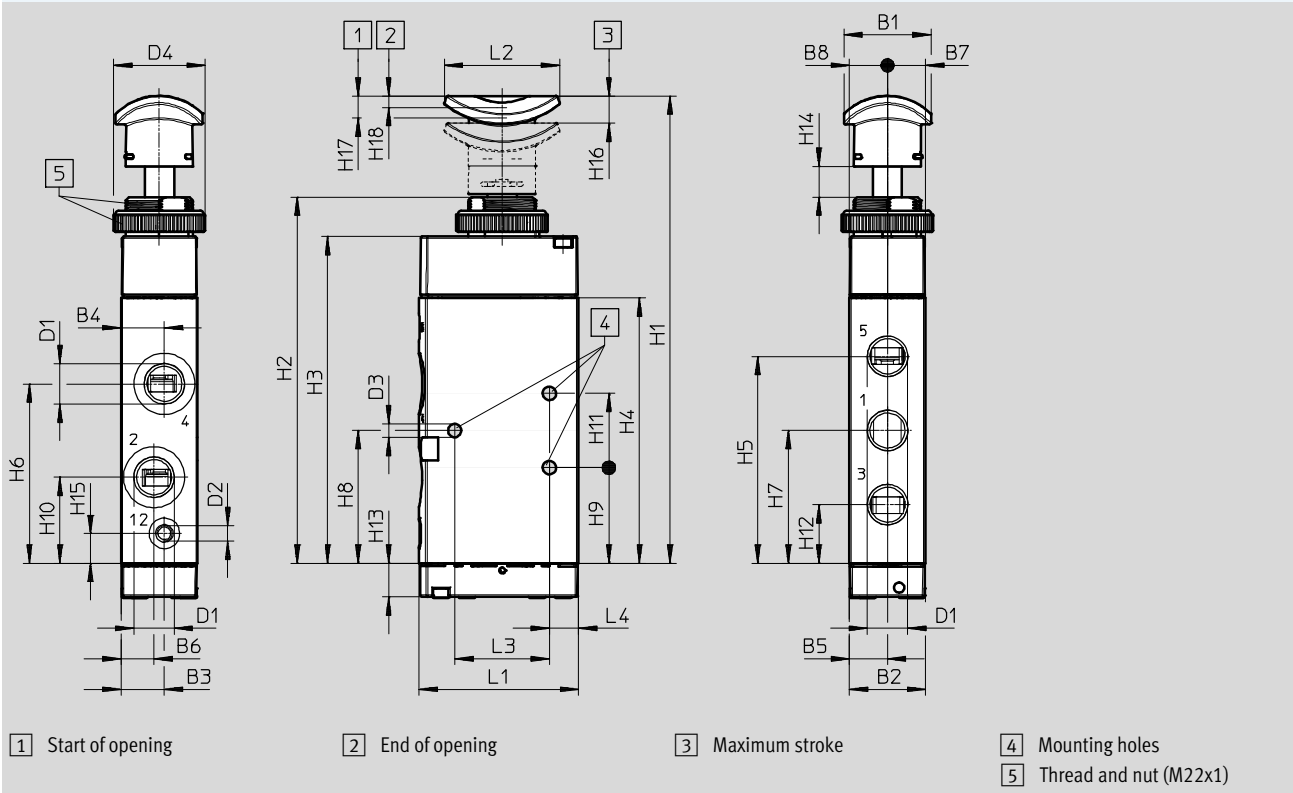

Pushbutton valve	B1	B2	B3	B4	B5	B6	B7	B8	D1	D2	D3	D4	L1	L2	L3	L4	H1	H2
VHEM-P...52...G14	28.5	25	14.2	14.2	12.5	10.8	9.5	9.5	G¼	M5	4.4	30	52.1	37.8	31	9.5	153.2	120
VHEM-P...52...G18	28.5	20	11.5	11.5	10	8.5	7.5	7.5	G⅛	M5	4.4	30	41.7	37.8	25	7	130.2	97

Pushbutton valve	H3	H4	H5	H6	H7	H8	H9	H10	H11	H12	H13	H14	H15	H16	H17	H18
VHEM-P...52...G14	107	87	67.8	58.8	43.5	43.5	31.4	28.2	24.3	19.2	11	10	9.8	9	5.3	3.8
VHEM-P...52...G18	84	64	49.5	41.8	32	32	23	22.3	18	14.5	11.8	10	9.3	7.5	4.5	3.2

Pushbutton valves



Ordering data

Ordering data											
Nominal flow rate	Valve function	Description	Mechanical reset	Normal position	Pilot air ¹⁾	Part No.	Type				
Pushbutton valve											
80 l/min	3/2-way valve, monostable	With PK-3, tubing connector	■	Open/closed	–	13793	K/O-3-PK3				
		With M5 threaded connection	■	Closed	–	3660	K-3-M5				
					–	4452	F-3-M5				
500 l/min	3/2-way valve, monostable	–	■	Closed	Internal	558405	VHEM-PTC-M32C-M-G18				
					External	558426	VHEM-PTCZ-M32C-M-G18				
				Open	Internal	558425	VHEM-PTC-M32U-M-G18				
					External	558411	VHEM-PTCZ-M32U-M-G18				
	5/2-way valve, monostable	Suitable for vacuum, reversible	■	–	–	–	558414	VHEM-P-M52-M-G18			
				–	–	–	558419	VHEM-P-M52-E-G18			
				–	–	–	558418	VHEM-P-M52-A-G18			
	5/2-way valve, bistable	Suitable for vacuum, reversible	■	–	–	–	558420	VHEM-PA-B52-G18			
				1000 l/min	5/2-way valve, monostable	Suitable for vacuum, reversible	■	–	–	558421	VHEM-P-M52-M-G14
						Suitable for vacuum, reversible	–	–	–	558424	VHEM-P-M52-E-G14
–	–	–	–			558423	VHEM-P-M52-A-G14				
5/2-way valve, bistable	Suitable for vacuum	■	–	–	–	558422	VHEM-PA-B52-G14				

1) With piloted valves

Toggle lever valves

Technical data – Toggle lever valve, 80 l/min standard nominal flow rate

-  Flow rate
80 l/min
 -  Pressure
0 ... 8 bar
 -  Temperature range
-10 ... +60 °C
- Mounting either via through-hole or on front panel



General technical data		
Type	KH/O-3-PK-3	
Standard nominal flow rate [l/min]	80	
1 → 2		
Valve functions	3/2-way valve	
Design	Disk seat valve, directly actuated	
Pneumatic connection	PK-3 ¹⁾	
Nominal size [mm]	2.5	
Weight [g]	20	
Actuating force [N]	-	
• at 6 bar		
• with normally closed [N]	7.5	
• with normally open [N]	6.5	

1) PK-3=Barbed fitting for plastic tubing with 3 mm nominal diameter

Materials	
Seal	Nitrile rubber
Housing	Plastic

Operating and environmental conditions		
Operating medium	Compressed air to ISO 8573-1:2010 [7:-:-]	
Note about the operating/pilot medium	Lubricated operation possible (required during subsequent operation)	
Operating pressure range [bar]	0 ... 8	
Ambient temperature [°C]	-10 ... +60	

Toggle lever valves

Technical data – Toggle lever valve

Dimensions

Download CAD data → www.festo.com

Toggle lever valve KH/O-3-PK-3

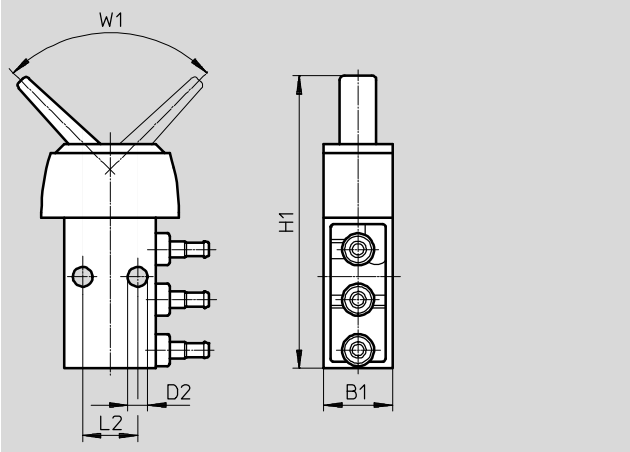

Mounting bracket HV-M5

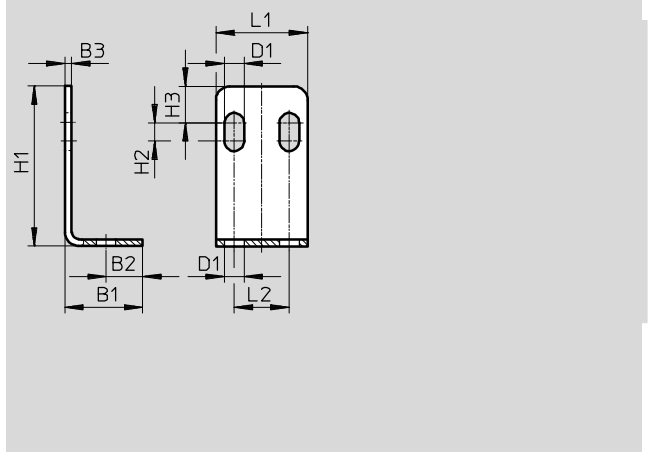



	B1	B2	B3	D1	D2	H1	H2	H3	L1	L2	W1
Toggle lever valve KH/O-3-PK-3	15	–	–	–	4.3	64	–	–	–	12	90°
Mounting bracket HV-M5	17	8	1.5	4.3	–	35	4	8	20	12	–

Ordering data

Nominal flow rate	Valve function	Description	Mechanical reset	Normal position	Part No.	Type
80 l/min	3/2-way valve, monostable	With PK-3, tubing connector	■	Open/closed	33003	KH/O-3-PK3

Finger lever valves

Technical data – Finger lever valve, standard nominal flow rate 80 ... 600 l/min

-  Flow rate
80 ... 1,000 l/min
 -  Pressure
-0.95 ... 10 bar
 -  Temperature range
-10 ... +60 °C
- Mounting either via through-hole or on front panel



General technical data					
Type	TH/O-3-PK-3	TH-3-M5	TH-5-1/4-B	TH-3-1/4-B	THO-3-1/4-B
Standard nominal flow rate [l/min] 1 → 2	80		550	600	
Valve function	3/2-way valve		5/2-way valve	3/2-way valve	
Design	Disk seat valve, directly actuated		Disk seat valve, directly actuated	Disk seat valve, directly actuated	
Pneumatic connection	PK-3 ¹⁾	M5	G1/4	G1/4	G1/4
Nominal size [mm]	2.5	2.0	7.0	7.0	7.0
Weight [g]	18	37	320	210	210
Actuating force [N]	-	8.0	24.0	6.7	17.0
• at 6 bar					
• with normally closed position	[N]	8.0	-	-	
• with normally open position	[N]	6.0	-	-	

1) PK-3=Barbed fitting for plastic tubing with 3 mm nominal diameter

Materials					
Type	TH/O-3-PK-3	TH-3-M5	TH-5-1/4-B	TH-3-1/4-B	THO-3-1/4-B
Seal	NBR				
Housing	Plastic	Die-cast zinc	Die-cast aluminium		

Operating and environmental conditions					
Type	TH/O-3-PK-3	TH-3-M5	TH-5-1/4-B	TH-3-1/4-B	THO-3-1/4-B
Operating medium	Compressed air to ISO 8573-1:2010 [7:-:-]				
Note about the operating/pilot medium	Lubricated operation possible (required during subsequent operation)				
Operating pressure range [bar]	0 ... 8	-0.95 ... 8	-0.95 ... 10		
Ambient temperature [°C]	-10 ... +60				

Finger lever valves

Technical data – Finger lever valve, standard nominal flow rate 500 ... 1,000 l/min

General technical data						
Type	VHEM-LT		VHEM-L	VHEM-L ... M	VHEM-L	VHEM-L ... M
Standard nominal flow rate [l/min] 1 → 2	500	1,000	500		1,000	
Valve function	3/2-way valve	3/2-way valve	5/2-way valve		5/2-way valve	
Reset method	Mechanical spring	Mechanical spring	Pneumatic spring	Mechanical spring	Pneumatic spring	Mechanical spring
Design	Disk seat valve, directly actuated	Disk seat valve, directly actuated	Piston spool valve, directly actuated	Piston spool valve, directly actuated	Piston spool valve, directly actuated	Piston spool valve, directly actuated
Pneumatic connection	G $\frac{1}{8}$	G $\frac{1}{4}$	G $\frac{1}{8}$	G $\frac{1}{8}$	G $\frac{1}{4}$	G $\frac{1}{4}$
Pilot air supply	–	–	–	–	–	–
Nominal size [mm]	4.0	6.0	4.0	4.0	6.0	6.0
Weight [g]	148	216	164	164	336	336
Actuating force [N]	23.5 ¹⁾ 34.7	31.0 ²⁾ 47.4	10.2	6.8	23.8	12.8

1) Value 23.5 with normally closed valve, value 34.7 with normally open valve

2) Value 31.0 with normally closed valve, value 47.4 with normally open valve

Materials	
Seal	NBR
Housing	Anodised wrought aluminium alloy
Note on materials	RoHS-compliant

Operating and environmental conditions						
Type	VHEM-LT		VHEM-L	VHEM-L ... M	VHEM-L	VHEM-L ... M
Operating medium	Compressed air to ISO 8573-1:2010 [7:-:-]					
Note about the operating/pilot medium	Lubricated operation possible (required during subsequent operation)					
Operating pressure range	[bar]	–0.95 ... 10	–0.95 ... 10 ¹⁾	–0.95 ... 10 ¹⁾	–0.95 ... 10 ¹⁾	–0.95 ... 10 ¹⁾
	[bar]		2.5 ... 10 ²⁾		2.5 ... 10 ²⁾	
Temperature of medium	[°C]	–10 ... +60				
Ambient temperature	[°C]	–10 ... +60				

1) Suitable for vacuum, mechanical spring or external pneumatic spring reset method (in the type codes Reset method M: Mechanical spring or E: External pneumatic spring)

2) Not suitable for vacuum, internal pneumatic spring reset method (in the type codes Reset method A: Internal pneumatic spring)

Finger lever valves

Technical data – Finger lever valve

FESTO

Dimensions

Download CAD data → www.festo.com

Finger lever valve TH/O-3-PK-3

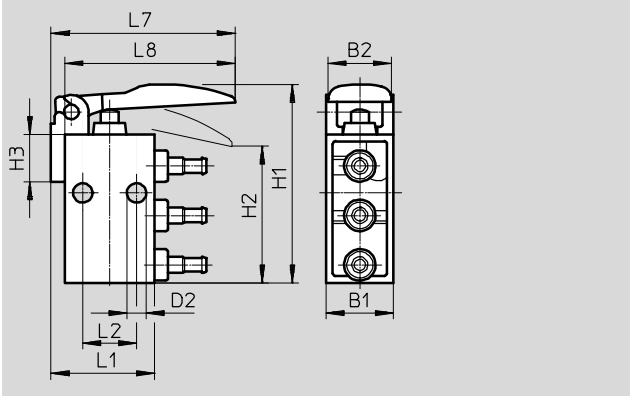

Finger lever valve TH-3-M5

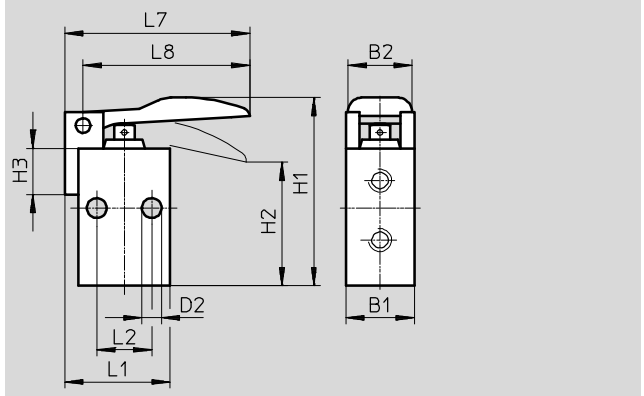

Finger lever valve	B1	B2	D2	H1	H2	H3	L1	L2	L7	L8
TH/O-3-PK-3	15	14	4.3	44.6	30.4	10.5	23	12	41	38
TH-3-M5	14.8	14	4.3	42	27	10	23	12	40.5	36.5

Finger lever valve TH-3-1/4-B, THO-3-1/4-B

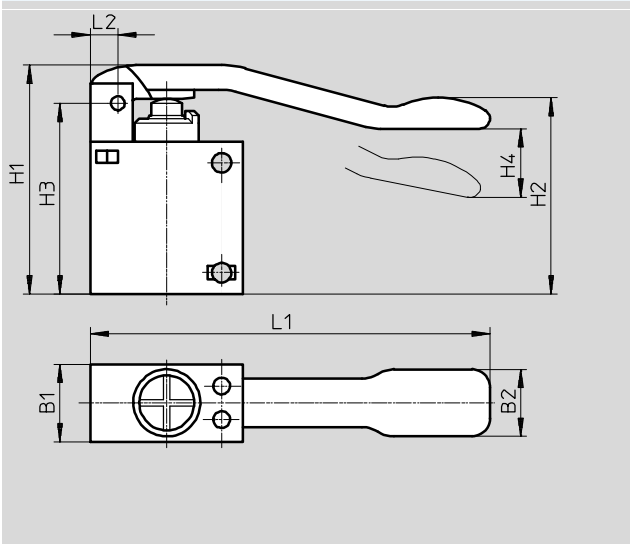

Finger lever valve TH-5-1/4-B

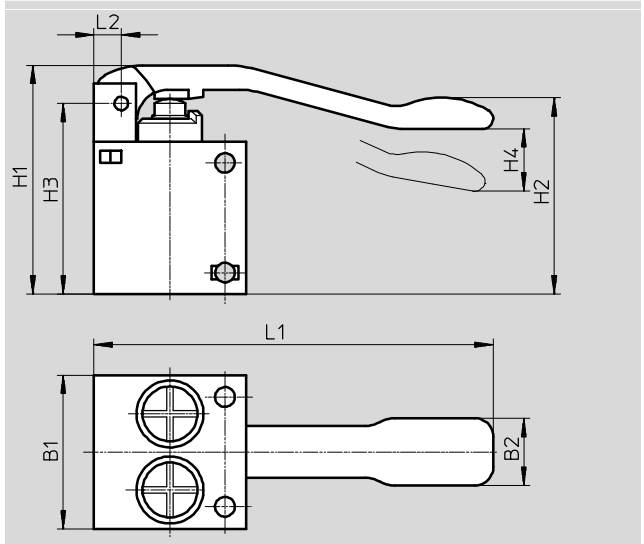

Finger lever valve	B1	B2	H1	H2	H3	H4	L1	L2
TH-3-1/4-B, THO-3-1/4-B	25.4	22	75	68	62.5	23	131	9
TH-5-1/4-B	50.4	22	75	68	62.5	23	131	9

Finger lever valves

Technical data – Finger lever valve

Dimensions

Download CAD data → www.festo.com

Mounting bracket HV-M5

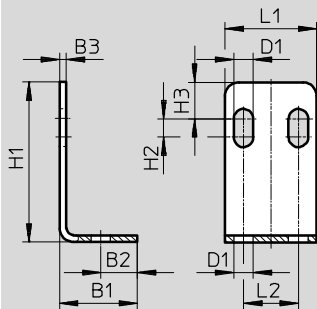

Mounting bracket	B1	B2	B3	D1	H1	H2	H3	L1	L2
HV-M5	17	8	1.5	4.3	35	4	8	20	12

Finger lever valve VHEM-L- ... 52 ... G14

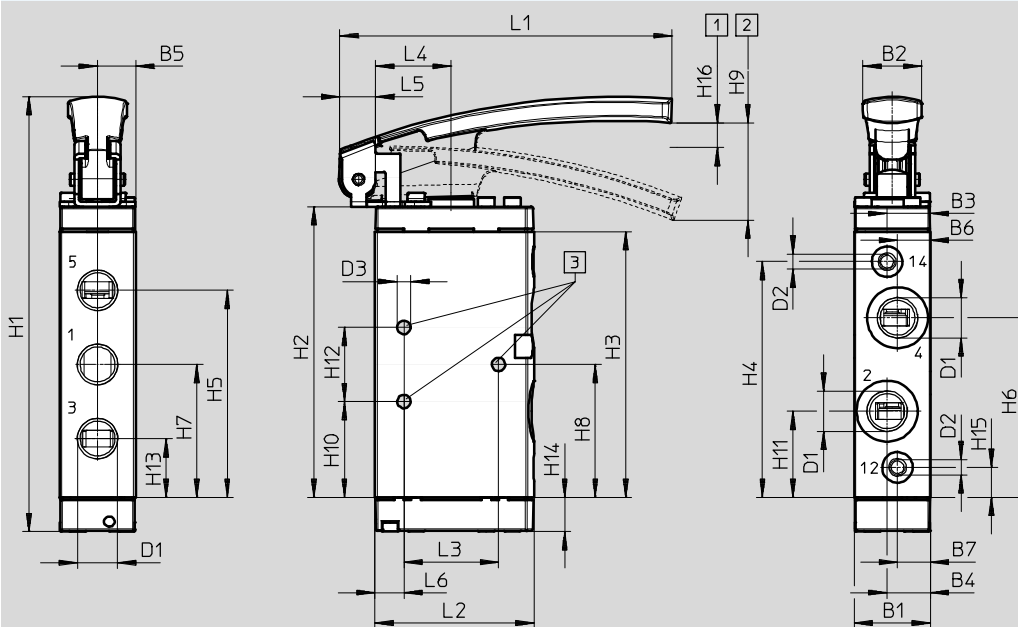

1 Start of opening 2 Maximum stroke 3 Mounting holes

Finger lever valve	B1	B2	B3	B4	B5	B6	B7	D1	D2	D3	L1	L2	L3	L4	L5	L6
VHEM-L...52...G14	25	19.3	14.2	14.2	12.5	10.8	10.8	G1/4	M5	4.4	109.1	52.1	31	25	11.7	9.5

Finger lever valve	H1	H2	H3	H4	H5	H6	H7	H8	H9	H10	H11	H12	H13	H14	H15	H16
VHEM-L...52...G14	142.5	95.3	87	77.2	67.8	58.8	43.5	43.5	31.9	31.4	28.2	24.3	19.2	11.3	9.8	8.1

Finger lever valves

Technical data – Finger lever valve

FESTO

Dimensions

Download CAD data → www.festo.com

Finger lever valve VHEM-L- ... 52 ... G18

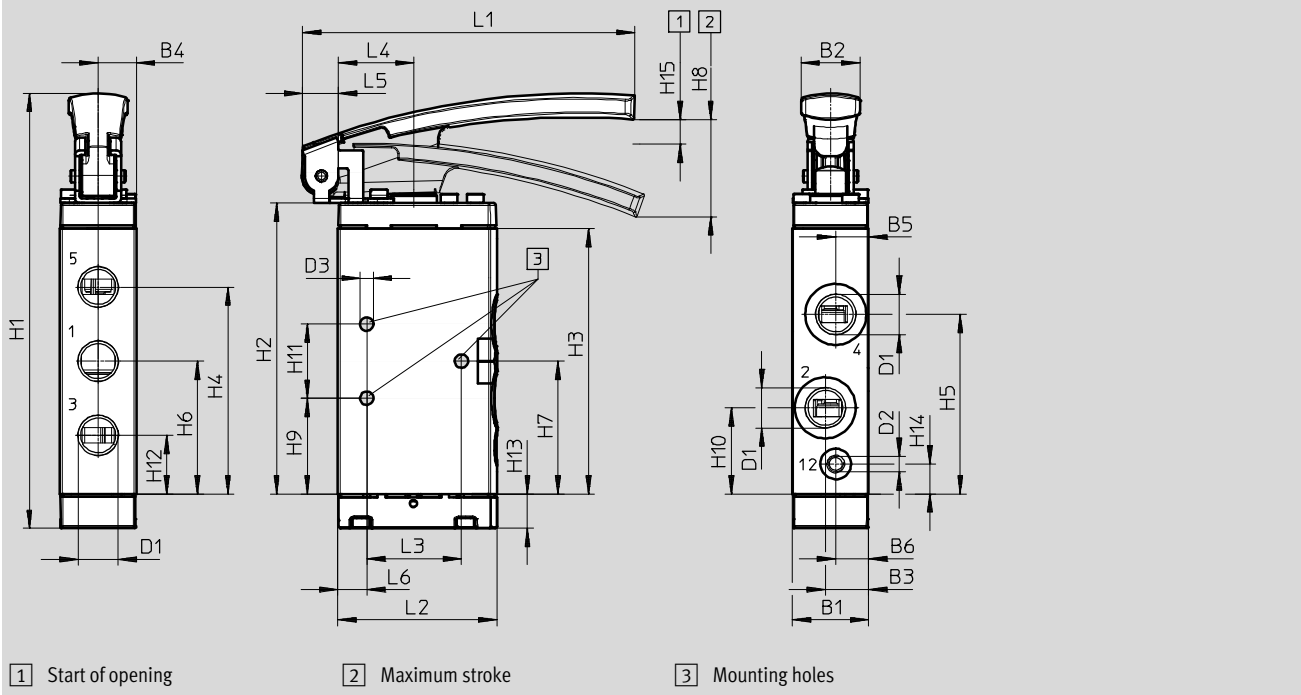

Finger lever valve	B1	B2	B3	B4	B5	B6	D1	D2	D3	L1	L2	L3	L4	L5	L6
VHEM-L...52...G18	20	19.3	11.5	8.5	8.5	8.5	G $\frac{1}{8}$	M5	4.4	108.6	41.7	25	20	10.5	7

Finger lever valve	H1	H2	H3	H4	H5	H6	H7	H8	H9	H10	H11	H12	H13	H14	H15
VHEM-L...52...G18	120.3	82.9	64	49.5	41.7	32	32	35.9	23	22.2	18	14.5	11.8	9.3	9.1

Finger lever valves

Technical data – Finger lever valve

Dimensions

Download CAD data → www.festo.com

Finger lever valve VHEM-LT... 32

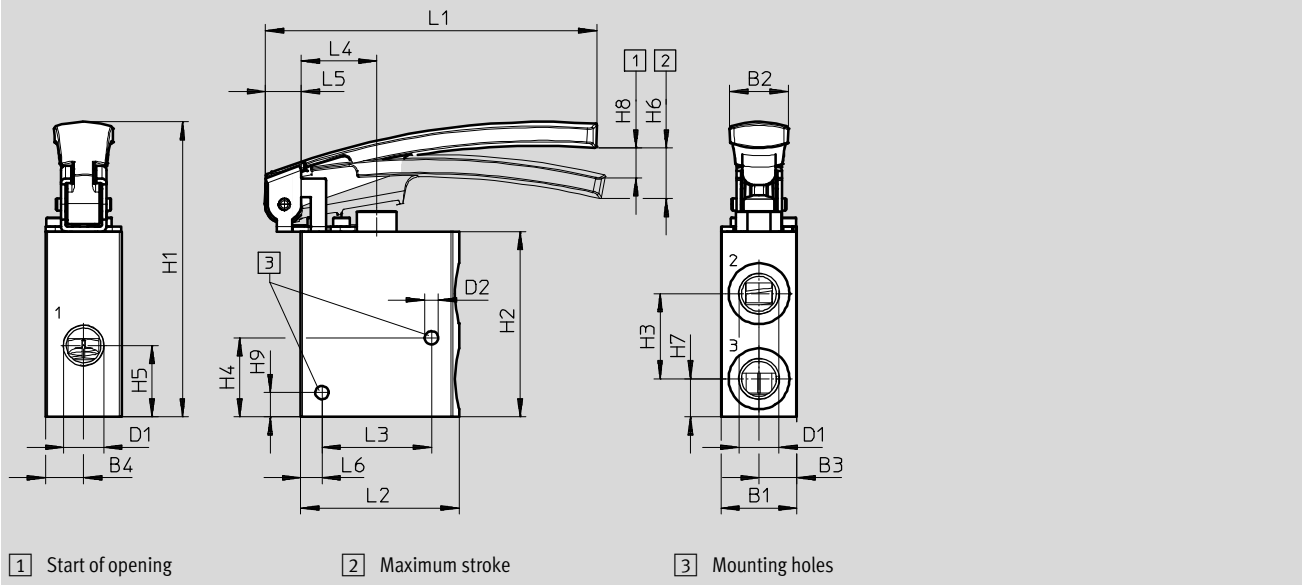

Finger lever valve	B1	B2	B3	B4	D1	D2	L1	L2	L3	L4	L5	L6
VHEM-LT...32...G14	25	19.3	12.5	12.5	G1/4	4.4	109.1	52.1	36	25	11.7	7
VHEM-LT...32...G18	20	19.3	10	10	G1/8	4.4	108.5	41.7	28	20	10.4	6

Finger lever valve	H1	H2	H3	H4	H5	H6	H7	H8	H9
VHEM-LT...32...G14	97	61	28	26	23.5	16.6	12.5	9.8	8
VHEM-LT...32...G18	88.4	51	25	26	17.5	15.1	10	7.65	8.5

Finger lever valves

Ordering data

Ordering data						
Nominal flow rate	Valve function	Description	Mechanical reset	Normal position	Part No.	Type
Finger lever valve						
80 l/min	3/2-way valve, monostable	With PK-3, tubing connector	■	Open/closed	13794	TH/O-3-PK3
			■	Closed	6758	TH-3-M5
500 l/min	3/2-way valve, monostable	Suitable for vacuum	■	Closed	563777	VHEM-LT-M32C-M-G18
				Open	563781	VHEM-LT-M32U-M-G18
	5/2-way valve, monostable	Suitable for vacuum	■	–	561323	VHEM-L-M52-M-G18
				–	561324	VHEM-L-M52-A-G18
	Reversible	–	561325	VHEM-L-M52-E-G18		
550 l/min	5/2-way valve, monostable	–	■	Closed	8994	TH-5-1/4-B
600 l/min	3/2-way valve, monostable	–	■	Closed	8983	TH-3-1/4-B
		–	■	Open	8990	THO-3-1/4-B
1000 l/min	3/2-way valve, monostable	Suitable for vacuum	■	Closed	561326	VHEM-LT-M32C-M-G14
				Open	563977	VHEM-LT-M32U-M-G14
	5/2-way valve, monostable	Suitable for vacuum	■	–	563978	VHEM-L-M52-M-G14
				–	563979	VHEM-L-M52-A-G14
	Reversible	–	563980	VHEM-L-M52-E-G14		

Hand lever valves

Technical data – Hand lever valve, standard nominal flow rate 550 ... 600 l/min

-  - Flow rate
550 ... 600 l/min

Mounting either via through-hole or
on front panel

-  - Pressure
-0.95 ... 10 bar

-  - Temperature range
-10 ... +60 °C



General technical data		
Type	H-5-1/4-B	H-3-1/4-B
Standard nominal flow rate [l/min] 1 → 2	550	600
Valve function	5/2-way valve	3/2-way valve
Design	Disk seat valve, directly actuated	Disk seat valve, directly actuated
Pneumatic connection	G1/4	G1/4
Nominal size [mm]	7.0	7.0
Weight [g]	510	320
Actuating force [N]	22.0	5.5

Materials	
Seal	NBR
Housing	Die-cast aluminium

Operating and environmental conditions	
Operating medium	Compressed air to ISO 8573-1:2010 [7:-:-]
Note about the operating/ pilot medium	Lubricated operation possible (required during subsequent operation)
Operating pressure range [bar]	-0.95 ... 10
Ambient temperature [°C]	-10 ... +60

Hand lever valves

Technical data – Hand lever valve

FESTO

Dimensions

Download CAD data → www.festo.com

Hand lever valve H-3-1/4-B

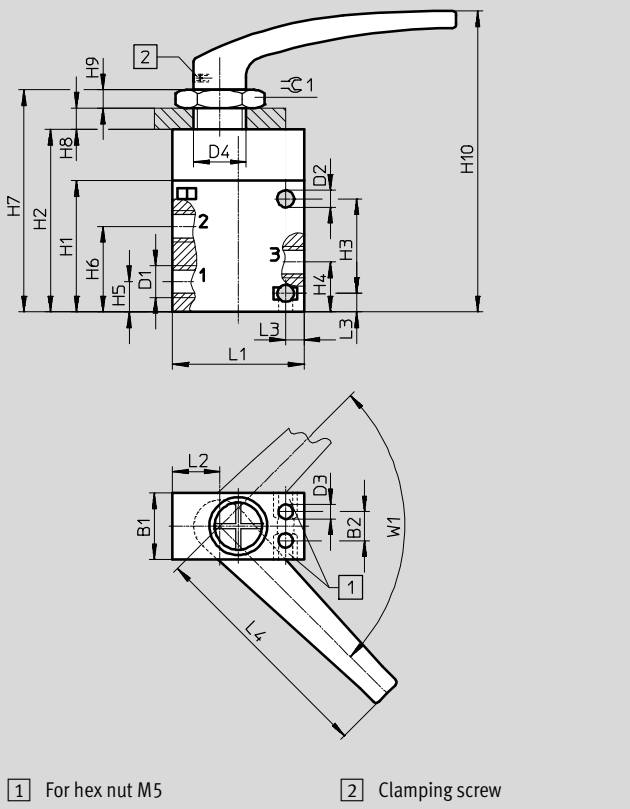

Hand lever valve H-5-1/4-B

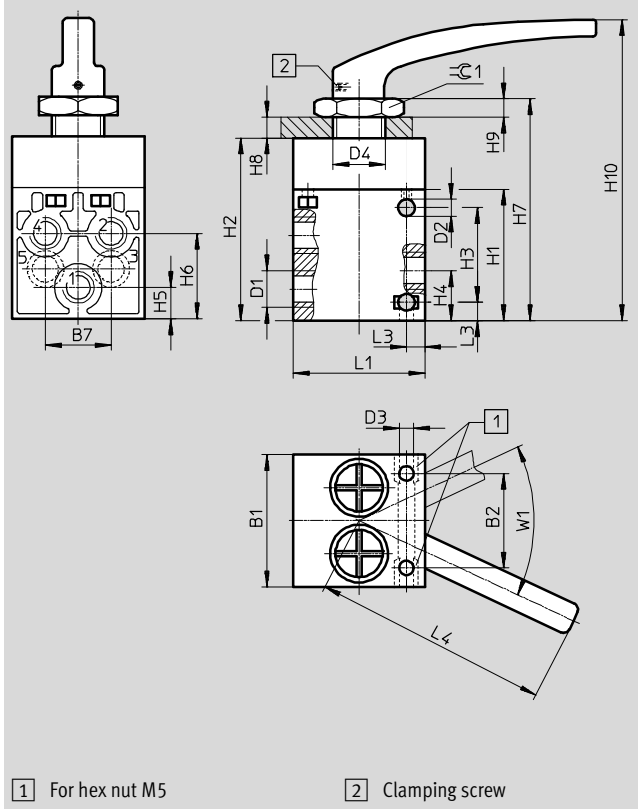

Hand lever valve	H1	H2	H3	H4	H5	H6	H7	H8	H9	H10
H-3-1/4-B	50	69.5	36	19	11.5	32.5	84.5	0 ... 8	7	114.5
H-5-1/4-B	50	69.5	36	19	11.5	32.5	84.5	0 ... 8	7	114.5

Hand lever valve	B1	B2	B7	D1	D2	D3	D4	L1	L2	L3	L4	W1	∠ 1
H-3-1/4-B	25.4	11	-	G1/4	6.4	5.5	M20x1.5	50	18	7	90	90°	30
H-5-1/4-B	50.4	36	25	G1/4	6.4	5.5	M20x1.5	50	-	7	90	50°	30

Ordering data

Nominal flow rate	Valve function	Part No.	Type
Hand lever valve			
600 l/min	3/2-way valve, bistable	8987	H-3-1/4-B
	5/2-way valve, bistable	8995	H-5-1/4-B

Foot valves, foot valves with detent

Technical data – Foot valve, standard nominal flow rate 550 ... 600 l/min

-  Flow rate
550 ... 600 l/min

Mounted via flange eyes on the housing

-  Pressure
-0.95 ... 10 bar

-  Temperature range
-10 ... +60 °C



General technical data							
Type	FPB-3-1/4	F-5-1/4-B	FP-5-1/4-B	FPB-5-1/4	F-3-1/4-B	FO-3-1/4-B	FP-3-1/4-B
Standard nominal flow rate [l/min] 1 → 2	550				600		
Valve function	3/2-way valve	5/2-way valve			3/2-way valve		
Design	Disk seat valve, directly actuated	Disk seat valve, directly actuated	Disk seat valve, directly actuated	Disk seat valve, directly actuated	Disk seat valve, directly actuated	Disk seat valve, directly actuated	Disk seat valve, directly actuated
Pneumatic connection	G1/4	G1/4	G1/4	G1/4	G1/4	G1/4	G1/4
Nominal size [mm]	7.0	7.0	7.0	7.0	7.0	7.0	7.0
Weight [g]	610	705	1,845	725	595	595	1,760
Actuating force [N]	34.0	52.0	69.0	66.0	26.0	37.0	45.0

Materials	
Seal	NBR
Housing	Die-cast aluminium

Operating and environmental conditions	
Operating medium	Compressed air to ISO 8573-1:2010 [7:4:4]
Operating pressure range [bar]	-0.95 ... 10
Ambient temperature [°C]	-10 ... +60

Foot valves, foot valves with detent

Technical data

Dimensions

Download CAD data → www.festo.com

Foot valve F... 3 ... , foot valve with detent FPB-3 ...

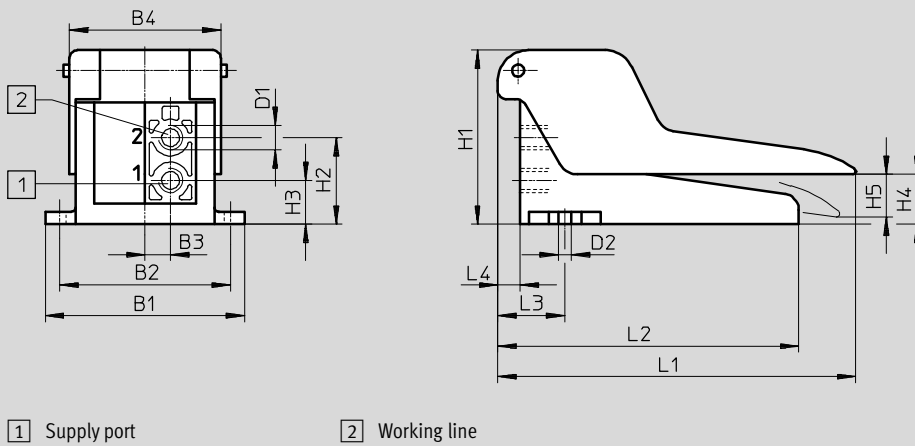

Foot valve F-5 ... , foot valve with detent FPB-5 ...

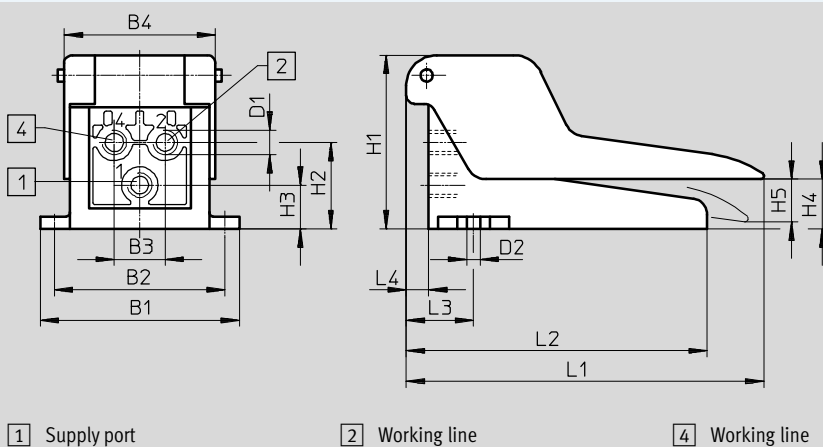

Type	B1	B2	B3	B4	D1	D2	H1	H2	H3	H4	H5	L1	L2	L3	L4
Foot valve F... 3 ... , foot valve with detent FPB-3 ...	98	84	12.5	74.4	G $\frac{1}{4}$	6.5	85.5	42.5	21.5	29	24	176	148	33	11
Foot valve F-5 ... , Foot valve with detent FPB-5 ...	98	84	25	74.4	G $\frac{1}{4}$	6.5	85.5	42.5	21.5	29	24	176	148	33	11

Foot valves, foot valves with detent

Technical data

Dimensions

Download CAD data → www.festo.com

Foot valve with detent FP-3-1/4-B

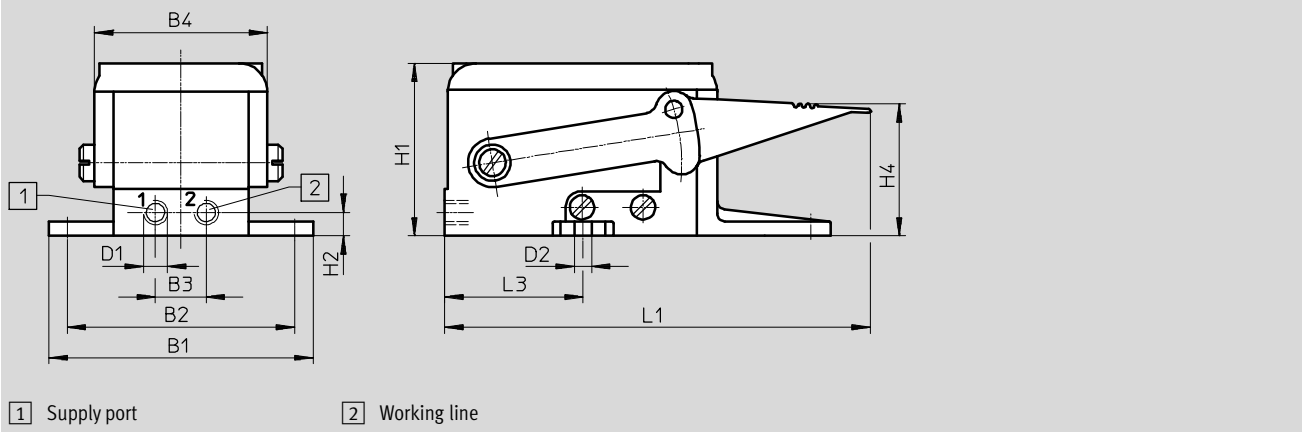

Foot valve with detent FP-5-1/4-B

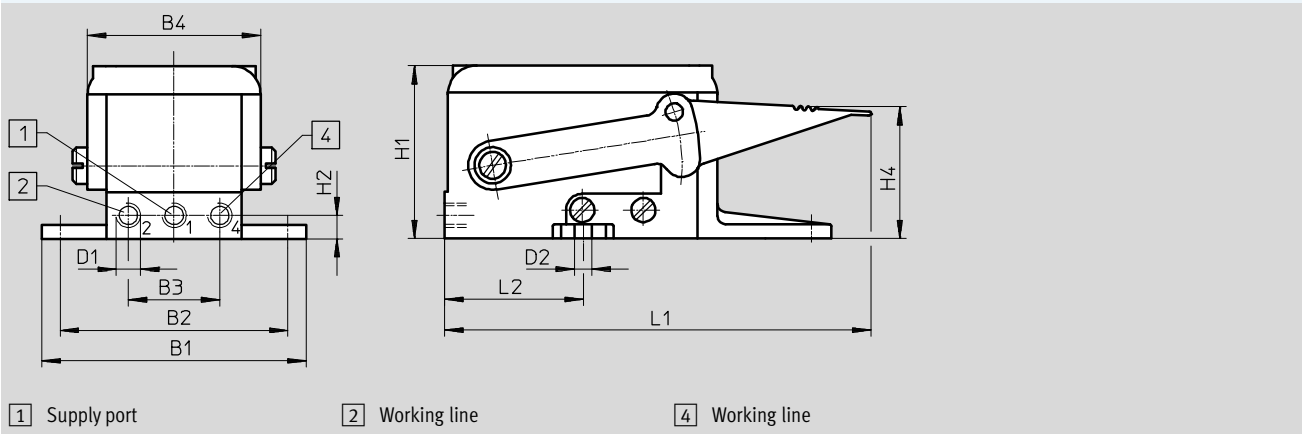

Foot valve with detent	B1	B2	B3	B4	D1	D2	H1	H2	H4	L1	L3
FP-3-1/4-B	130	112	25	85	G1/4	8.5	85	11.5	65	210	68
FP-5-1/4-B	130	112	45	85	G1/4	8.5	85	11.5	65	210	68

Safety guard FH, for foot valve F and foot valve with detent FPB

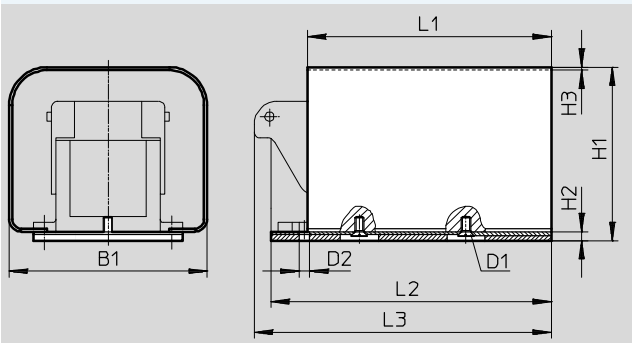

Safety guard FPH-121, for foot valve with detent FP

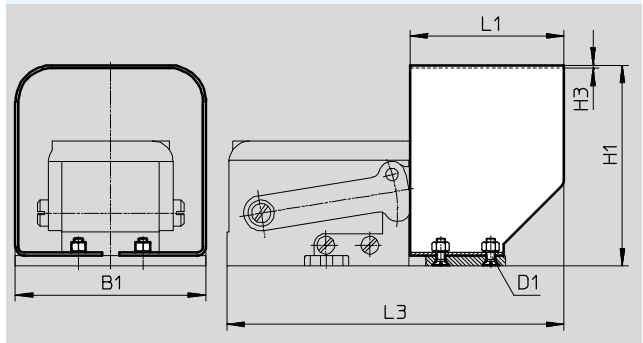

Safe guard	B1	D1	D2	H1	H2	H3	L1	L2	L3
FH	130	M6	7	114	6	2	160	184	195
FPH-121	130	M6	-	137	-	2	105	-	230

Foot valves, foot valves with detent

Ordering data

Ordering data						
Nominal flow rate	Valve function	Description	Mechanical reset	Normal position	Part No.	Type
Foot valve						
550 l/min	3/2-way valve, bistable	Suitable for vacuum	■	–	526984	FPB-3-1/4
	5/2-way valve, bistable	Suitable for vacuum	■	–	526985	FPB-5-1/4
		Suitable for vacuum	■	–	8997	FP-5-1/4-B
	5/2-way valve, monostable	Suitable for vacuum	■	Open	8992	F-5-1/4-B
600 l/min	3/2-way valve, bistable	Suitable for vacuum	■	–	8986	FP-3-1/4-B
	3/2-way valve, monostable	Suitable for vacuum	■	Closed	8984	F-3-1/4-B
		Suitable for vacuum	■	Open	8988	FO-3-1/4-B

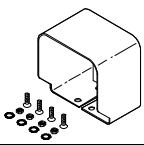

Ordering data					
	Description		Part No.	Type	PU ¹⁾
Safety guard					
	For foot valve F and foot valve with detent FPB	1240 g	4500	FH	1
	For foot valve FP	670 g	2071	FPH-121	1

1) Packaging unit

Valves, manually operated

Accessories

FESTO

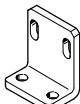
Ordering data					
	Description		Part No.	Type	PU ¹⁾
Push-in fitting with external hex					
	Connecting thread M5 for tubing O.D.	3 mm	153302	QSM-M5-3	10
		4 mm	153304	QSM-M5-4	10
		6 mm	153306	QSM-M5-6	10
	Connecting thread G $\frac{1}{8}$ for tubing O.D.	4 mm	186095	QS-G $\frac{1}{8}$ -4	10
			186264	QSM-G $\frac{1}{8}$ -4	10
		6 mm	186096	QS-G $\frac{1}{8}$ -6	10
			186265	QSM-G $\frac{1}{8}$ -6	10
	Connecting thread G $\frac{1}{4}$ for tubing O.D.	6 mm	186097	QS-G $\frac{1}{4}$ -6	10
		8 mm	186099	QS-G $\frac{1}{4}$ -8	10
		10 mm	186101	QS-G $\frac{1}{4}$ -10	10
Push-in fitting with internal hex					
	Connecting thread M5 for tubing O.D.	3 mm	153313	QSM-M5-3-I	10
		4 mm	153315	QSM-M5-4-I	10
		6 mm	153315	QSM-M5-6-I	10
	Connecting thread G $\frac{1}{8}$ for tubing O.D.	4 mm	186106	QS-G $\frac{1}{8}$ -4-I	10
			186266	QSM-G $\frac{1}{8}$ -4-I	10
		6 mm	186107	QS-G $\frac{1}{8}$ -6-I	10
			186267	QSM-G $\frac{1}{8}$ -6-I	10
	Connecting thread G $\frac{1}{4}$ for tubing O.D.	8 mm	186109	QS-G $\frac{1}{8}$ -8-I	10
		6 mm	186108	QS-G $\frac{1}{4}$ -6-I	10
		8 mm	186110	QS-G $\frac{1}{4}$ -8-I	10
10 mm	186112	QS-G $\frac{1}{4}$ -10-I	10		
Silencer					
	Connecting thread	G $\frac{1}{8}$	2307	U- $\frac{1}{8}$	1
			161419	UC- $\frac{1}{8}$	1
		G $\frac{1}{4}$	2316	U- $\frac{1}{4}$	1
			6842	U- $\frac{1}{4}$ -B	1
			165004	UC- $\frac{1}{4}$	1
Mounting bracket					
	For valves with push-in connector and threaded connection	11 g	9634	HV-M5	1
		32 g	9635	HV- $\frac{1}{8}$	1

1) Packaging unit

Product Range and Company Overview

A Complete Suite and Company Overview

Our experienced engineers provide complete support at every stage of your development process, including: conceptualization, analysis, engineering, design, assembly, documentation, validation, and production.



Custom Automation Components
Complete custom engineered solutions

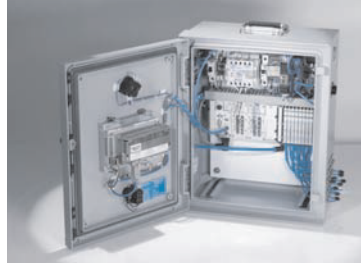

Custom Control Cabinets
Comprehensive engineering support and on-site services



Complete Systems
Shipment, stocking and storage services

The Broadest Range of Automation Components

With a comprehensive line of more than 30,000 automation components, Festo is capable of solving the most complex automation requirements.



Electromechanical
Electromechanical actuators, motors, controllers & drivers



Pneumatics
Pneumatic linear and rotary actuators, valves, and air supply



PLCs and I/O Devices
PLC's, operator interfaces, sensors and I/O devices

Supporting Advanced Automation... As No One Else Can!

Festo is a leading global manufacturer of pneumatic and electromechanical systems, components and controls for industrial automation, with more than 16,000 employees in 60 national headquarters serving more than 180 countries. For more than 80 years, Festo has continuously elevated the state of manufacturing with innovations and optimized motion control solutions that deliver higher performing, more profitable automated manufacturing and processing equipment. Our dedication to the advancement of automation extends beyond technology to the education and development of current and future automation and robotics designers with simulation tools, teaching programs, and on-site services.

Quality Assurance, ISO 9001 and ISO 14001 Certifications

Festo Corporation is committed to supply all Festo products and services that will meet or exceed our customers' requirements in product quality, delivery, customer service and satisfaction.

To meet this commitment, we strive to ensure a consistent, integrated, and systematic approach to management that will meet or exceed the requirements of the ISO 9001 standard for Quality Management and the ISO 14001 standard for Environmental Management.



© Copyright 2013, Festo Corporation. While every effort is made to ensure that all dimensions and specifications are correct, Festo cannot guarantee that publications are completely free of any error, in particular typing or printing errors. Accordingly, Festo cannot be held responsible for the same. For Liability and Warranty conditions, refer to our "Terms and Conditions of Sale", available from your local Festo office. All rights reserved. No part of this publication may be reproduced, distributed, or transmitted in any form or by any means, electronic, mechanical, photocopying or otherwise, without the prior written permission of Festo. All technical data subject to change according to technical update.



Printed on recycled paper at New Horizon Graphic, Inc., FSC certified as an environmental friendly printing plant.

Festo North America

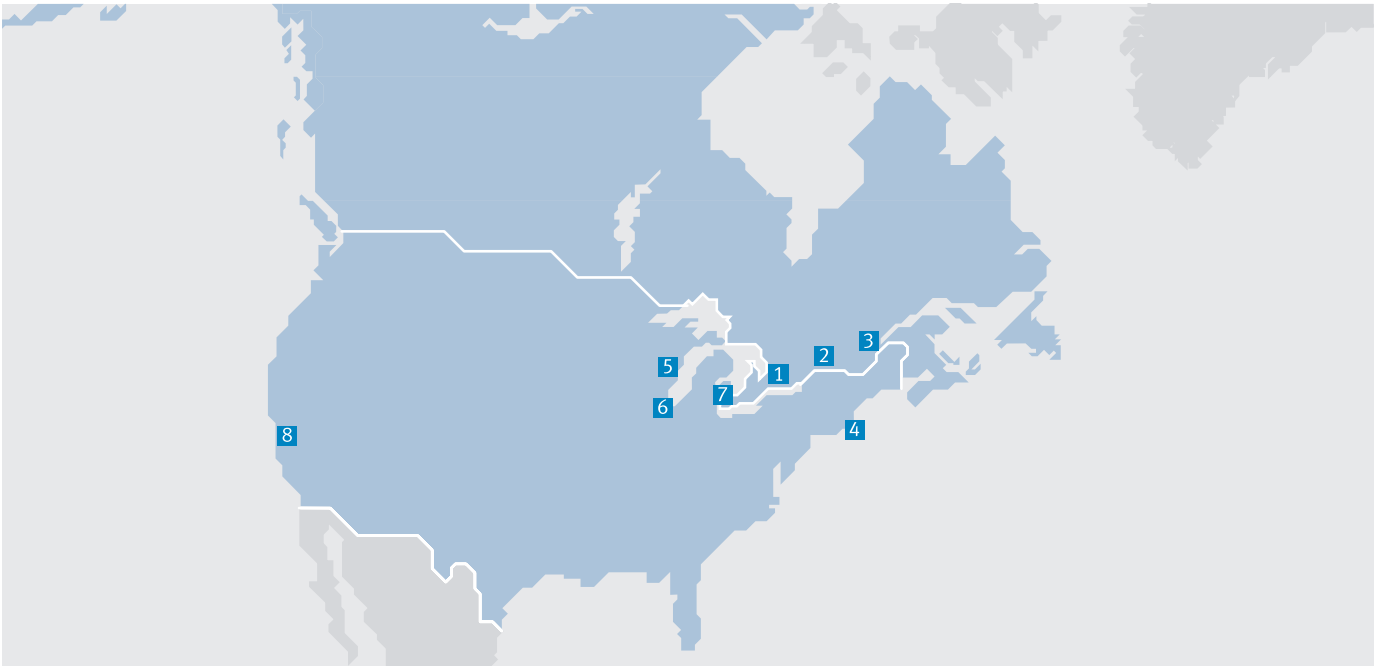

**1 Festo Canada
Headquarters
Festo Inc.**
5300 Explorer Drive
Mississauga, ON
L4W 5G4

2 Montréal
5600, Trans-Canada
Pointe-Claire, QC
H9R 1B6

3 Québec City
2930, rue Watt#117
Québec, QC
G1X 4G3



**4 Festo United States
Headquarters
Festo Corporation**
395 Moreland Road
Hauppauge, NY
11788

5 Appleton
North 922 Tower View Drive, Suite N
Greenville, WI
54942

7 Detroit
1441 West Long Lake Road
Troy, MI
48098

6 Chicago
85 W Algonquin - Suite 340
Arlington Heights, IL
60005

8 Silicon Valley
4935 Southfront Road, Suite F
Livermore, CA
94550

Festo Regional Contact Center

Canadian Customers

Commercial Support:
Tel: 1 877 GO FESTO (1 877 463 3786)
Fax: 1 877 FX FESTO (1 877 393 3786)
Email: festo.canada@ca.festo.com

Technical Support:
Tel: 1 866 GO FESTO (1 866 463 3786)
Fax: 1 877 FX FESTO (1 877 393 3786)
Email: technical.support@ca.festo.com

USA Customers

Commercial Support:
Tel: 1 800 99 FESTO (1 800 993 3786)
Fax: 1 800 96 FESTO (1 800 963 3786)
Email: customer.service@us.festo.com

Technical Support:
Tel: 1 866 GO FESTO (1 866 463 3786)
Fax: 1 800 96 FESTO (1 800 963 3786)
Email: product.support@us.festo.com