

# Accessories for valves and valve terminals VAME, mounting attachments

Technical data

Mounting attachments enable valve terminals to be attached to walls and machine parts.



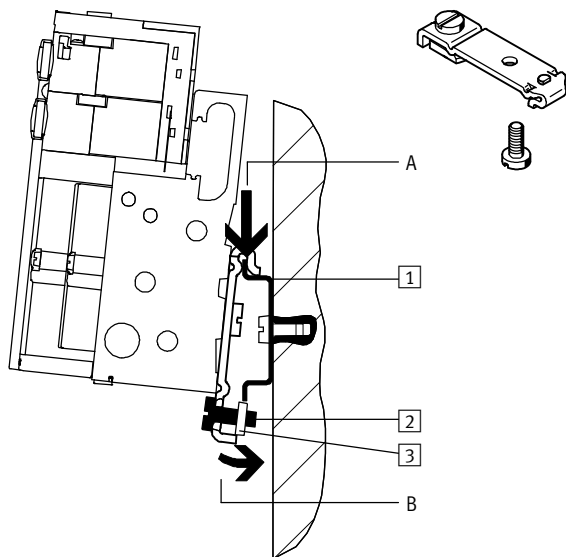

## Examples illustrating H-rail mounting

Via mounting rail

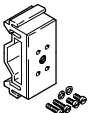
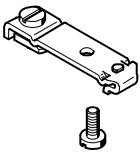

The valve terminal is attached to the H-rail (see arrow A) and then swivelled onto the H-rail and secured in place with the clamping component (see arrow B).

- 1 Holes for wall mounting
- 2 Self-tapping M4x10 screw of the H-rail clamping unit
- 3 Clamping component of the H-rail clamping unit

Ordering data						
	Weight [g]	Material	Function	Dimensions [mm]	Part No.	Type
	35.1	Steel/polymer	Base for H-rail mounting. Is screwed onto the component and the entire unit can then be placed on an H-rail.	47x12x18.1 (LxWxH)	170169	CP-TS-HS-35
	29.9	Cold rolled steel	Mounting accessories (set) for H-rail mounting. Is screwed onto the component and the entire unit can then be placed on an H-rail. Includes M4x10 screw (combi cross-slot screws).	49.1x13x8.7 (LxWxH) Material thickness: 2	527392	CPASC-BG-NRH
	8.8	Fine grained cold pressed steel	Mounting bracket for mounting valve terminals on even surfaces. Includes 2 M3x9 screws (2.5 A/F internal hexagon socket).	18 x 15 (LxW) Material thickness: 2	534416	VMPA-BG-RW
	-	Galvanised steel	Screw available as spare part, to DIN 912.	L: 45; Thread: M3	527643	M3x45

# Accessories for valves and valve terminals VAME, mounting attachments



Technical data

## Mounting rail NR

Mounting rails for manifold mounting of components.

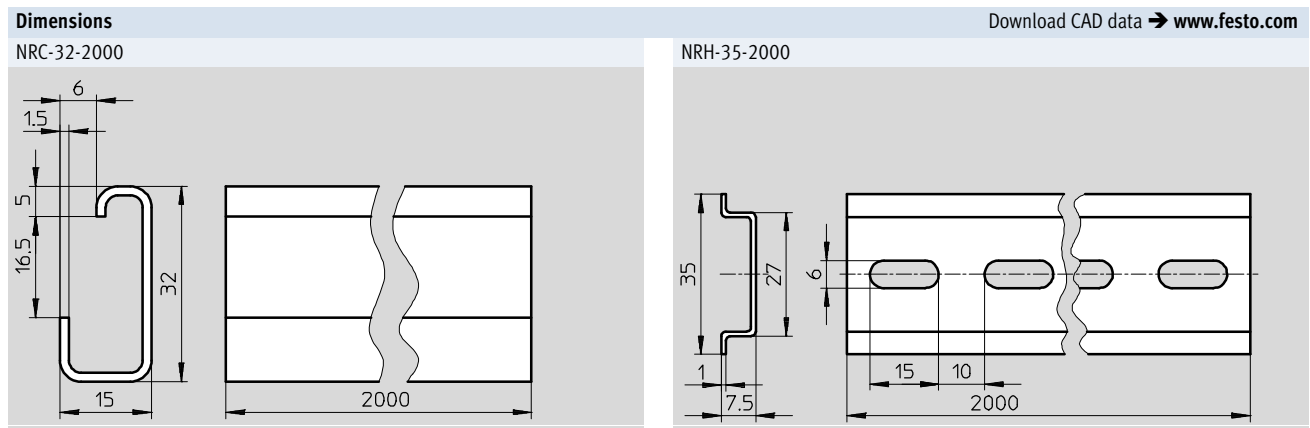
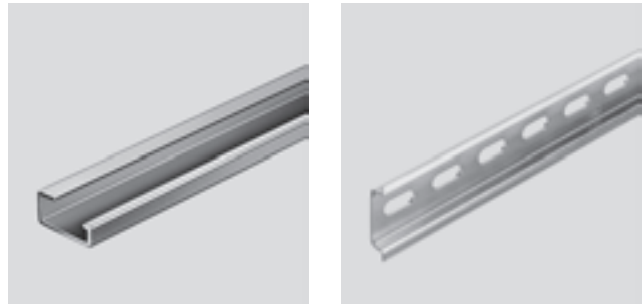
- G rail to DIN EN 50035
- H-rail to EN 60715



Ordering data						
	Description	Length [m]	Product weight [g]	Material	Part No.	Type
	G-rail to DIN EN 50 035	2	1400	Galvanised steel	<b>6756</b>	<b>NRC-32-2000</b>
	H-rail to EN 60715	2	600	Galvanised steel	<b>35430</b>	<b>NRH-35-2000<sup>1)</sup></b>

1) Free of copper, PTFE and silicone

## Product Range and Company Overview

### A Complete Suite and Company Overview

Our experienced engineers provide complete support at every stage of your development process, including: conceptualization, analysis, engineering, design, assembly, documentation, validation, and production.



**Custom Automation Components**  
Complete custom engineered solutions



**Custom Control Cabinets**  
Comprehensive engineering support and on-site services



**Complete Systems**  
Shipment, stocking and storage services

### The Broadest Range of Automation Components

With a comprehensive line of more than 30,000 automation components, Festo is capable of solving the most complex automation requirements.



**Electromechanical**  
Electromechanical actuators, motors, controllers & drivers



**Pneumatics**  
Pneumatic linear and rotary actuators, valves, and air supply



**PLCs and I/O Devices**  
PLC's, operator interfaces, sensors and I/O devices

### Supporting Advanced Automation... As No One Else Can!

Festo is a leading global manufacturer of pneumatic and electromechanical systems, components and controls for industrial automation, with more than 16,000 employees in 60 national headquarters serving more than 180 countries. For more than 80 years, Festo has continuously elevated the state of manufacturing with innovations and optimized motion control solutions that deliver higher performing, more profitable automated manufacturing and processing equipment. Our dedication to the advancement of automation extends beyond technology to the education and development of current and future automation and robotics designers with simulation tools, teaching programs, and on-site services.

### Quality Assurance, ISO 9001 and ISO 14001 Certifications

Festo Corporation is committed to supply all Festo products and services that will meet or exceed our customers' requirements in product quality, delivery, customer service and satisfaction.

To meet this commitment, we strive to ensure a consistent, integrated, and systematic approach to management that will meet or exceed the requirements of the ISO 9001 standard for Quality Management and the ISO 14001 standard for Environmental Management.



© Copyright 2013, Festo Corporation. While every effort is made to ensure that all dimensions and specifications are correct, Festo cannot guarantee that publications are completely free of any error, in particular typing or printing errors. Accordingly, Festo cannot be held responsible for the same. For Liability and Warranty conditions, refer to our "Terms and Conditions of Sale", available from your local Festo office. All rights reserved. No part of this publication may be reproduced, distributed, or transmitted in any form or by any means, electronic, mechanical, photocopying or otherwise, without the prior written permission of Festo. All technical data subject to change according to technical update.



Printed on recycled paper at New Horizon Graphic, Inc., FSC certified as an environmental friendly printing plant.

# Festo North America



**1 Festo Canada  
Headquarters  
Festo Inc.**  
5300 Explorer Drive  
Mississauga, ON  
L4W 5G4

**2 Montréal**  
5600, Trans-Canada  
Pointe-Claire, QC  
H9R 1B6

**3 Québec City**  
2930, rue Watt#117  
Québec, QC  
G1X 4G3



**4 Festo United States  
Headquarters  
Festo Corporation**  
395 Moreland Road  
Hauppauge, NY  
11788

**5 Appleton**  
North 922 Tower View Drive, Suite N  
Greenville, WI  
54942

**7 Detroit**  
1441 West Long Lake Road  
Troy, MI  
48098

**6 Chicago**  
85 W Algonquin - Suite 340  
Arlington Heights, IL  
60005

**8 Silicon Valley**  
4935 Southfront Road, Suite F  
Livermore, CA  
94550

## Festo Regional Contact Center

### Canadian Customers

Commercial Support:  
Tel: 1 877 GO FESTO (1 877 463 3786)  
Fax: 1 877 FX FESTO (1 877 393 3786)  
Email: festo.canada@ca.festo.com

Technical Support:  
Tel: 1 866 GO FESTO (1 866 463 3786)  
Fax: 1 877 FX FESTO (1 877 393 3786)  
Email: technical.support@ca.festo.com

### USA Customers

Commercial Support:  
Tel: 1 800 99 FESTO (1 800 993 3786)  
Fax: 1 800 96 FESTO (1 800 963 3786)  
Email: customer.service@us.festo.com

Technical Support:  
Tel: 1 866 GO FESTO (1 866 463 3786)  
Fax: 1 800 96 FESTO (1 800 963 3786)  
Email: product.support@us.festo.com