

Mini slides SLT/SLS/SLF

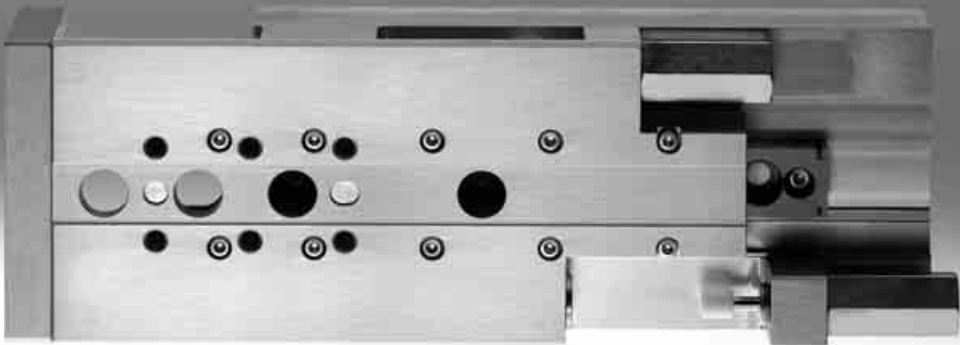

Mini slides SLT/SLS/SLF

Key features

FESTO

General information

- Double-acting drives
- Precise and rigid guide
- Versatile air connections
- Sensors can be integrated
- Highly flexible thanks to versatile, direct assembly and connection options on:
 - Drive body
 - Slide
 - Yoke plate

Mini slides SLT



- Powerful
- Compact design through air connections at rear
- Two adjustable end-position cushioning systems:
 - Flexible cushioning elements
 - Hydraulic shock absorbers
- Extremely compact drive thanks to cushioning systems integrated in the profile section
- Versatile combination options include:
 - Drives
 - Grippers
- System product for handling and assembly technology

Mini slides SLS



- Slim design
- Integrated end-position cushioning:
 - Flexible cushioning elements

Mini slides SLF



- Flat
- Adjustable end-position cushioning
 - Flexible cushioning elements
- Versatile combination options on:
 - Drives
- System product for handling and assembly technology

Mini slides SLT/SLS/SLF

System example

System product for handling and assembly technology

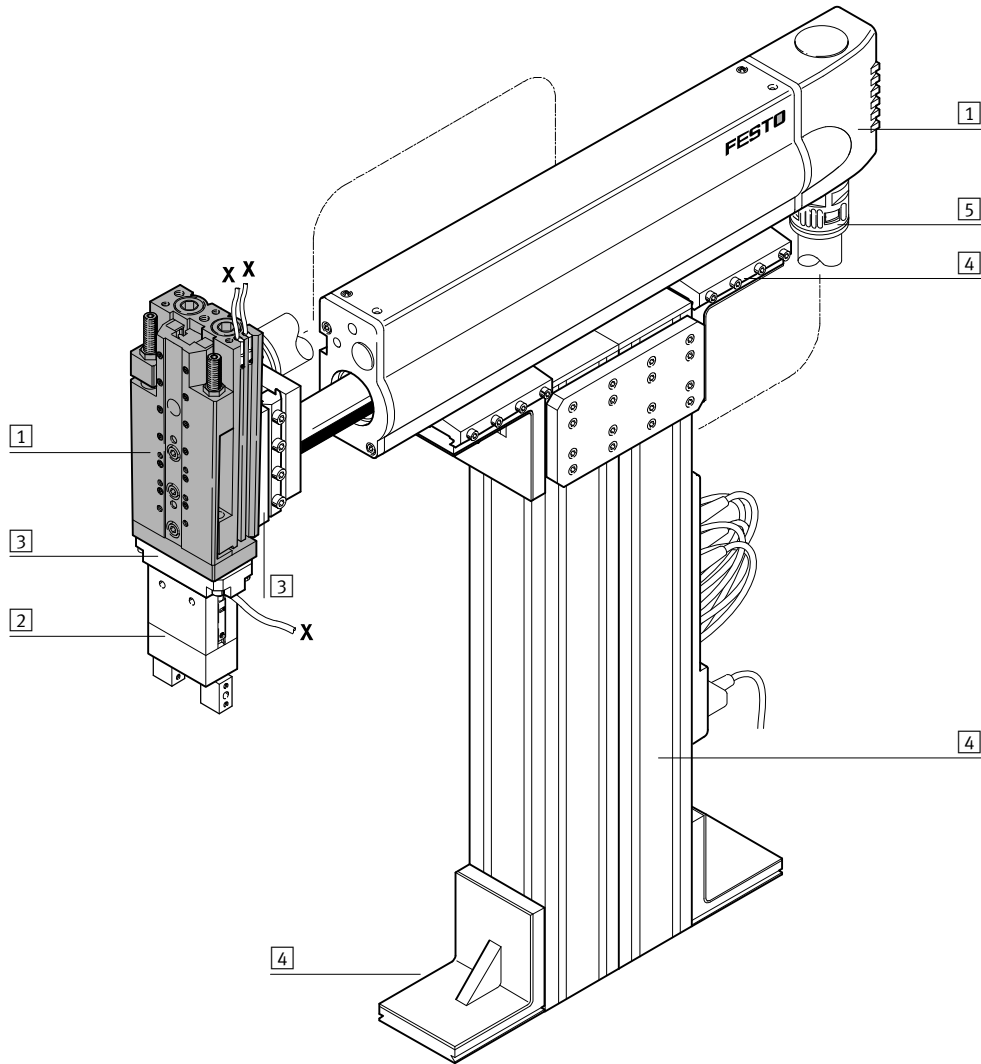

System elements and accessories		
	Brief description	→ Page/Internet
1	Drives	Diverse possible combinations in handling and assembly technology drive
2	Grippers	Wide range of variation options within handling and assembly technology gripper
3	Adapters	For drive/drive combinations 40
		For drive/gripper combinations gripper
4	Basic components	Profiles and profile connections as well as profile/drive connections basic component
5	Installation components	For achieving a clear-cut, safe layout of electrical cables and tubing installation component
-	Axes	Diverse possible combinations in handling and assembly technology axes
-	Motors	Servo and stepper motors, with or without gearing motor

Mini slides SLT/SLS/SLF

Key features



Drive

Mini slides SLT/SLS/SLF are driven with double-acting cylinders.

SLT: with two pistons

SLS/SLF: with one piston

Guide

The slide moves on a pre-loaded, backlash-free precision ball bearing cage guide of high rigidity with high torque and load absorption.

SLT/SLS/SLF-6/10/16

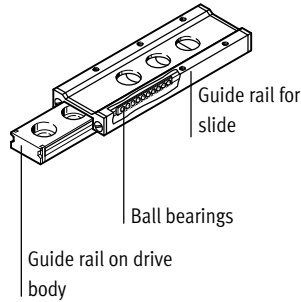

SLT-20/-25

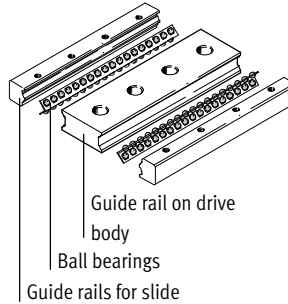

The powerful mini slide

SLT

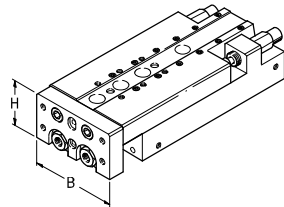

Piston \varnothing	Width (W)	x	Height (H)
2x 6 mm	35	x	20 mm
2x 10 mm	50	x	30 mm
2x 16 mm	66	x	40 mm
2x 20 mm	85	x	49 mm
2x 25 mm	104	x	60 mm

The super slim mini slide

SLS

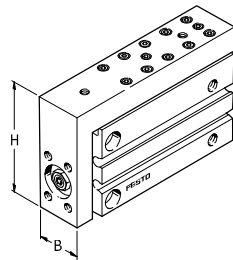

Piston \varnothing	Width (W)	x	Height (H)
6 mm	16	x	39 mm
10 mm	20	x	45 mm
16 mm	24	x	51 mm

The extremely flat mini slide

SLF

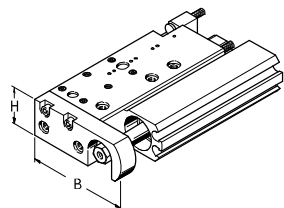

Piston \varnothing	Width (W)	x	Height (H)
6 mm	46	x	11 mm
10 mm	48	x	15 mm
16 mm	62	x	21 mm

Mini slides SLT/SLS/SLF

Key features

Versatile

through

- Attachment
- Mounting
- Air connection
- End-position cushioning
- Sensors

1 Attachment:
The drive can be directly attached via through or threaded holes (with appropriate screws and centring sleeves ZBH).

2 Mounting surface:
Direct attachment of devices and loads is made possible with threaded holes in the slide and the yoke plate (using appropriate screws and centring sleeves ZBS/ZBH) (e.g. SLT: semi-rotary drives and grippers).

3 Versatile air connections

- 4** Adjustable end-position cushioning systems:
- 1) SLT-...-P-A/SLF-...-P-A with flexible cushioning elements in the end positions
 - 2) SLT-...-P-A with stop PF-...-SLT allows precise, metallic positioning in the end positions
 - 3) SLT-...-A-CC-B with hydraulic shock absorbers YSRT on rear cover for optimum end-position adjustment

5 Sensors can be integrated
Sensor slots for one or more proximity sensors SME/SMT-10. For space-saving, reliable sensing of piston positions. Proximity sensors can be freely moved and clamped in their slots.

SLT
SLT-...-CC-B

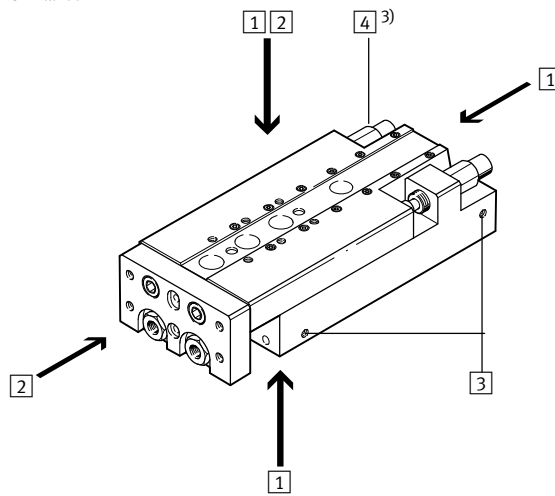

SLT-...-P-A

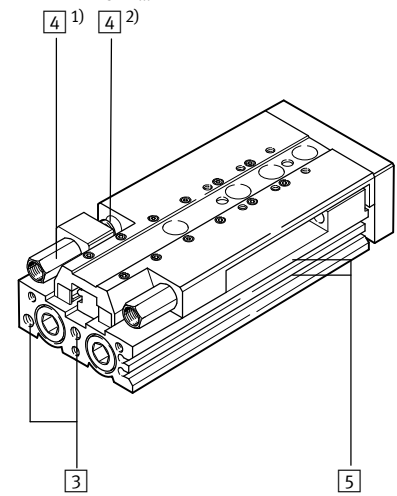

SLS

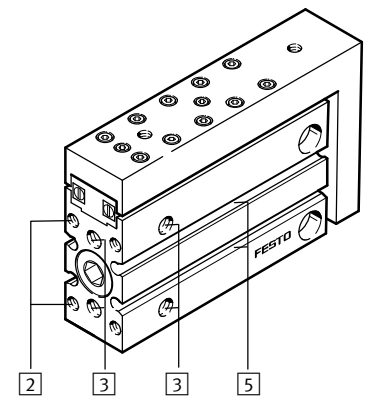
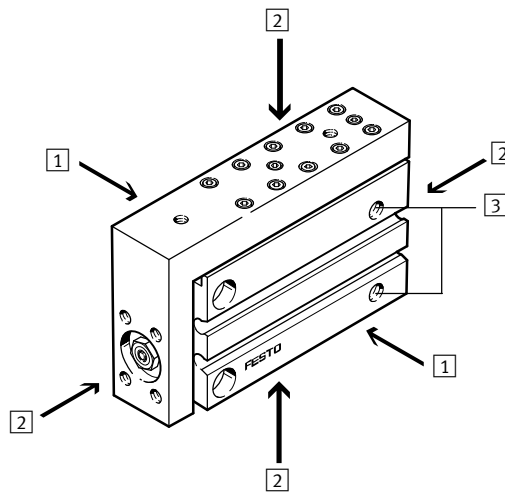

SLF

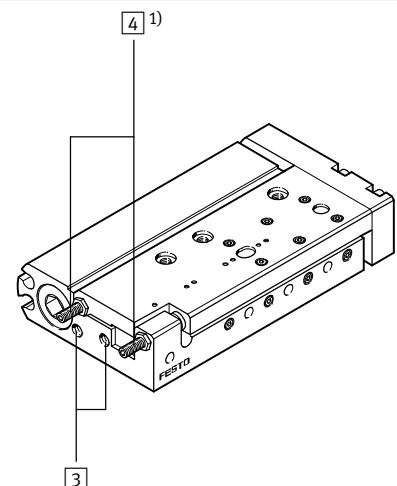
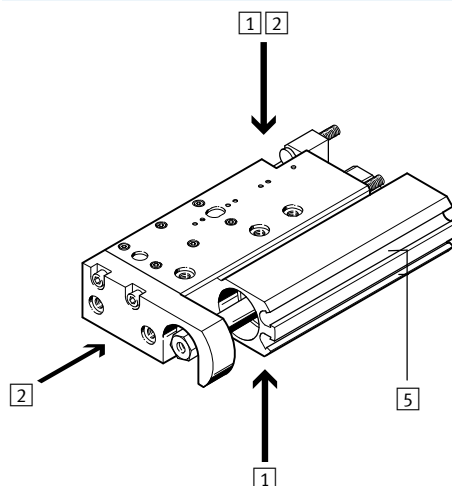

Mini slides SLT/SLS/SLF

Product range overview

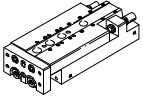
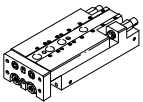
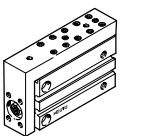
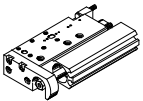

Function	Design	Piston Ø [mm]	Stroke [mm]	Cushioning		Position sensing	→ Page/ Internet
				flexible cushioning elements	hydraulic shock absorbers		
Double- acting	Powerful, SLT-...-P-A						
		6, 10, 16, 20, 25	10, 20, 30, 40, 50, 80, 100, 125, 150, 200	■	-	■	7
	Powerful, SLT-...-A-CC-B						
		10, 16, 20, 25	30, 40, 50, 80, 100, 125, 150, 200	-	■	■	7
	Slim, SLS-...-P-A						
	6, 10, 16	5, 10, 15, 20, 25, 30	■	-	■	21	
Flat, SLF-...-P-A							
	6, 10, 16	10, 20, 30, 40, 50, 80	■	-	■	29	

Mini slides SLT

Key features



Comparison between pneumatic mini slide SLT and electric mini slide SLTE

	Pneumatic: SLT	Electric: SLTE												
Advantages														
	<ul style="list-style-type: none"> • High feed force • High speed • Fast positioning time • Compact length 	<ul style="list-style-type: none"> • Gentle starting and stopping • Constant and precise speed (2 ... 200 mm/s) • Flexible positioning without mechanical devices • Programmable drive profile 												
Guide														
<ul style="list-style-type: none"> • Preloaded, backlash-free, precise and rigid ball bearing cage guide • High torque and load absorption 	<p>Guide rail for slide Ball bearings Guide rail on drive body</p>													
Dimensions														
<ul style="list-style-type: none"> • Identical width and height dimensions <table border="1"> <thead> <tr> <th>Type</th> <th>Width (B)</th> <th>x</th> <th>Height (H)</th> </tr> </thead> <tbody> <tr> <td>SLT(E)-10</td> <td>50</td> <td>x</td> <td>30 mm</td> </tr> <tr> <td>SLT(E)-16</td> <td>66</td> <td>x</td> <td>40 mm</td> </tr> </tbody> </table>	Type	Width (B)	x	Height (H)	SLT(E)-10	50	x	30 mm	SLT(E)-16	66	x	40 mm		
Type	Width (B)	x	Height (H)											
SLT(E)-10	50	x	30 mm											
SLT(E)-16	66	x	40 mm											
Interfaces														
<ul style="list-style-type: none"> • Identical mounting and attachment options <p>1 Mounting surfaces: Direct mounting using threaded holes and through-holes</p> <p>2 Attachment surfaces: Direct mounting of loads and devices (e.g. SLT: semi-rotary drives and grippers) by means of threaded holes in slide and yoke plate</p>														
Technical data														
Piston Ø	[mm]	6 ... 25	10, 16											
Stroke	[mm]	10 ... 200	50 ... 150											
Max. speed	[m/s]	0.8	0.2											
Repetition accuracy at end positions	[mm]	±0.02	±0.1											
Intermediate positions		None	Any											

Mini slides SLT

Peripherals overview

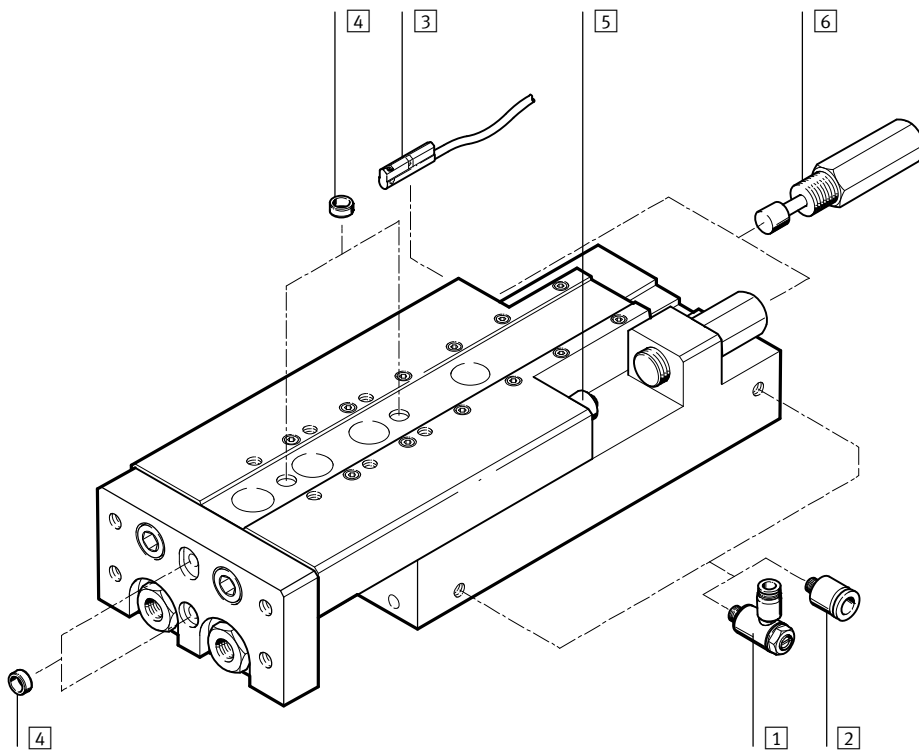

Note
End stops must not be removed.

Accessories		
	Brief description	→ Page/Internet
1	One-way flow control valve GRLA	38
2	Push-in fitting QS	quick star
3	Proximity sensor SME/SMT-10	39
4	Centring pin/sleeve ZBS/ZBH	38
5	Cushioning with stop PF	38
6	Cushioning with shock absorber YSRT	ysrt
7	Cushioning P	20

Cushioning variants

7 SLT...-P-A
with cushioning P

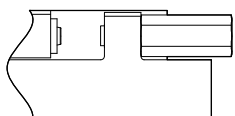

5 SLT...-P-A
with cushioning PF
(stop can be retrofitted)

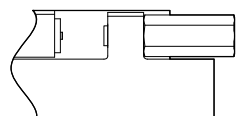

6 SLT...-CC-B
with cushioning YSRT

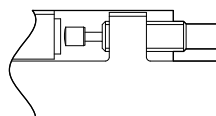

Mini slides SLT

Type codes

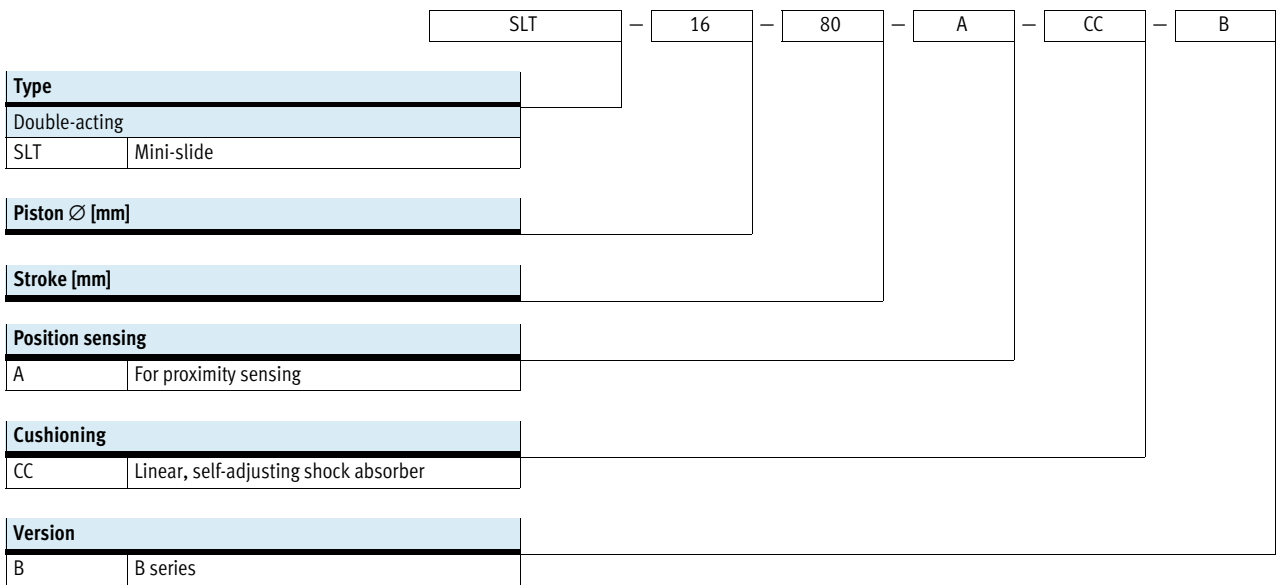
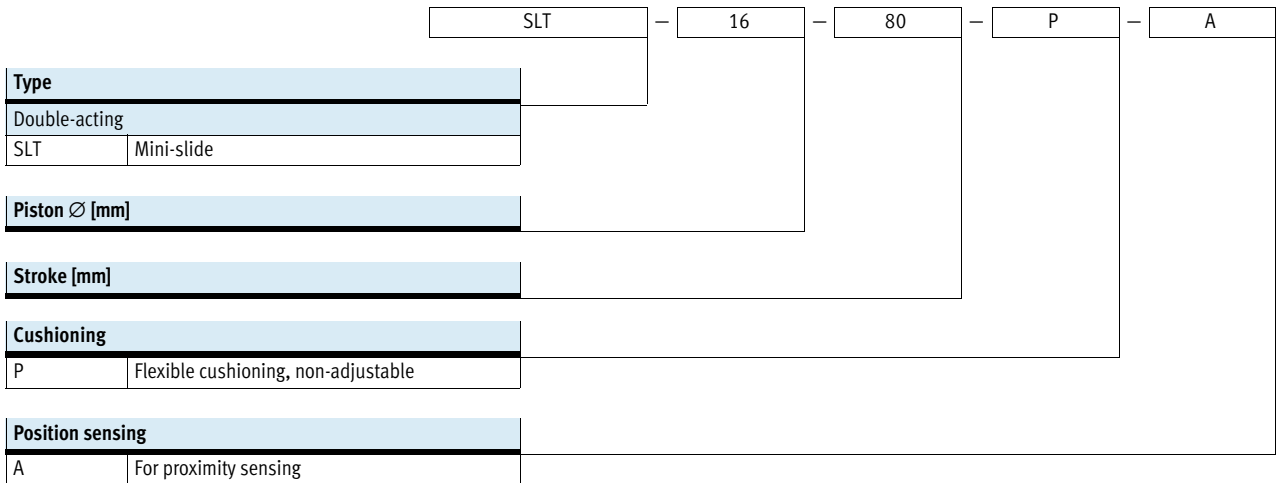

Mini slides SLT

Technical data

FESTO

Function

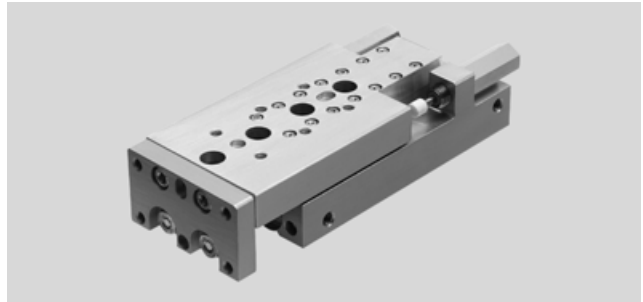
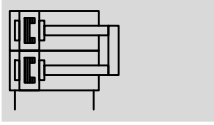

- - Diameter
6 ... 25 mm
- - Stroke length
10 ... 200 mm

General technical data				6	10	16	20	25
Piston \varnothing				6	10	16	20	25
Pneumatic connection				M5			G $\frac{1}{8}$	
Design				Kinematic yoke system				
Guide				Parallel piston rods, ball bearing guide				
Cushioning	Cushioning P			Non-adjustable at either end				
	Shock absorber			-			Self-adjusting at both ends	
Position sensing				For proximity sensing				
Type of mounting				Via through-holes				
				Via female thread				
Mounting position				Any				
Adjustable end-position range	Per end stop	[mm]		7	4	12		
	Per shock absorber	[mm]		-	4	5	12	
Cushioning length with shock absorbers		[mm]		-	5	8		12
Max. advancing speed		[m/s]		0.5 ¹⁾	0.8			
Max. retracting speed		[m/s]		0.5 ¹⁾	0.8			
Repetition accuracy	Stop PF	[mm]		0.02				
	Shock absorber	[mm]		-	0.02			

1) Must be throttled externally

Operating and environmental conditions				6	10	16	20	25
Piston \varnothing				6	10	16	20	25
Operating medium				Compressed air in accordance with ISO 8573-1:2010 [7:4:4]				
Note on operating/pilot medium				Operation with lubricated medium possible (in which case lubricated operation will always be required)				
Operating pressure		[bar]		1.5 ... 10	1 ... 10			
Ambient temperature ¹⁾		[°C]		-20 ... +60				

1) Note operating range of proximity sensors

Forces [N] and impact energy [Nm]				6	10	16	20	25
Piston \varnothing				6	10	16	20	25
Theoretical force at 6 bar, advancing				34	94	242	376	590
Theoretical force at 6 bar, retracting				25	79	218	317	495
Max. impact energy at the end positions ¹⁾	Stop PF ²⁾			0.0005	0.007	0.015	0.030	0.060
	Cushioning P ²⁾			0.016	0.1	0.3	0.4	0.5
	Shock absorber CC ²⁾			-	1	2	3	10

1) Loads moved by the slides must be taken into consideration for the calculation of end-position cushioning energy

2) Note also the graphs illustrating piston speed as a function of working load → 11

Mini slides SLT

Technical data

Weights [g]												
Piston Ø	Stroke	6		10		16		20		25		
		1	2	1	2	1	2	1	2	1	2	
1	Product weight	10	128	42	304	125	588	255	1,132	533	1,866	920
2	Moving load	20	145	47	298	122	568	250	1,117	526	1,852	905
		30	161	53	334	141	617	265	1,112	518	1,835	891
		40	184	64	365	149	690	298	1,199	548	2,002	964
		50	223	85	427	179	762	327	1,347	608	2,152	1,036
		80	-	-	581	247	1,030	451	1,767	793	2,767	1,326
		100	-	-	-	-	1,247	543	2,088	924	3,209	1,516
		125	-	-	-	-	1,655	749	2,681	1,143	4,030	1,899
		150	-	-	-	-	1,802	797	2,923	1,253	4,549	2,087
		200	-	-	-	-	-	-	3,666	1,490	5,520	2,544

Materials

Sectional view

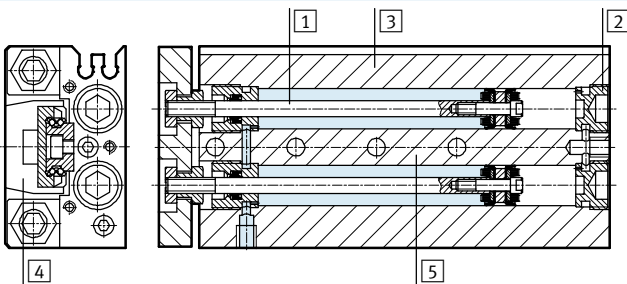

Mini slide		
1	Piston rod	High-alloy steel
2	Cap	Wrought aluminium alloy, anodised
3	Housing	Wrought aluminium alloy, anodised
4	Slide	Wrought aluminium alloy, anodised
5	Guide	Tempered steel
-	Seals	Hydrogenated nitrile rubber
Note on materials		Free of copper, PTFE and silicone

Piston speed v as a function of working load m

The piston speed as a function of working load may not be exceeded as the kinetic impact or residual energy

in the end positions can result in damage to the drive.

For the mini slide SLT with shock absorbers, the speed should not be less than 0.1 m/s, as otherwise the

service life of the shock absorber will be reduced.

SLT-6/-10/-16-...-P-A

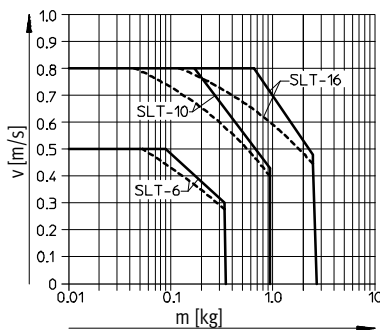

SLT-20-...-P-A

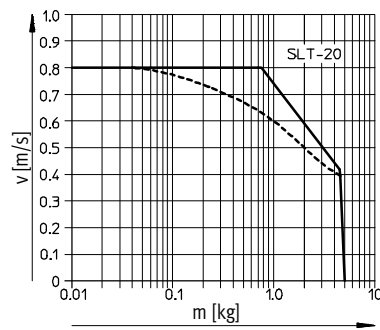

SLT-25-...-P-A

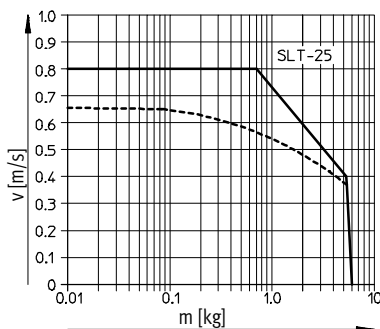

SLT-10/-16/-20/-25-...-A-CC-B

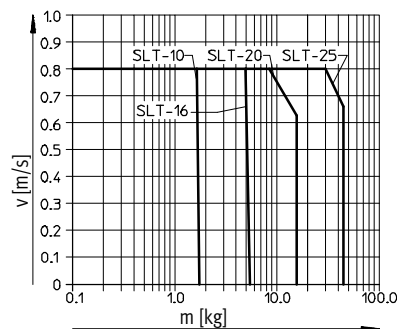

— Min. stroke
- - - Max. stroke

Mini slides SLT

Technical data

Dynamic characteristic load values

Torques are indicated with reference to the centre of the guide.
They must not be exceeded during dynamic operation. Special attention must be paid to the cushioning phase.

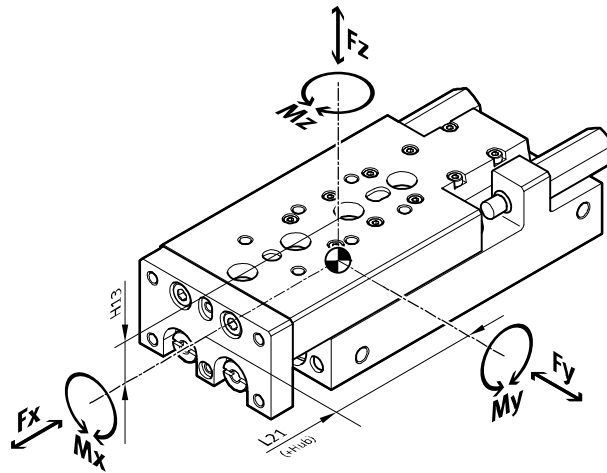

If the drive is simultaneously subjected to several of the indicated forces and torques, the following equation must be satisfied in addition to the indicated maximum loads.

$$\frac{|F_{y1}|}{F_{y\max.}} + \frac{|F_{z1}|}{F_{z\max.}} + \frac{|M_{x1}|}{M_{x\max.}} + \frac{|M_{y1}|}{M_{y\max.}} + \frac{|M_{z1}|}{M_{z\max.}} \leq 1$$

Position of guide centre

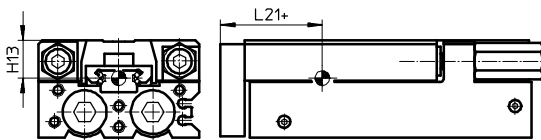

+ plus stroke length

Calculation example

Given:

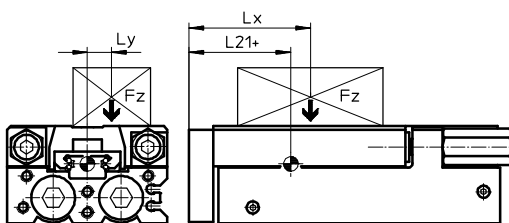

To be found:

Mini slide	= SLT-10	F _y , F _z , M _x , M _y , M _z and verification of function with combined load
Stroke length	= 80 mm	
Lever arm L _x	= 50 mm	
Lever arm L _y	= 30 mm	
Mass F _z	= 0.8 kg	
Acceleration a	= 0 m/s ²	

Solution:

L₂₁ = 41 mm from table

F_y = 0 N

F_z = m x g
= 0.8 kg x 9.81 m/s² = 7.848 N

M_x = m x g x L_y
= 0.8 kg x 9.81 m/s² x 30 mm = 0.236 Nm

M_y = m x g x [(L₂₁+stroke)-L_x]
= 0.8 kg x 9.81 m/s² [(41 mm + 80 mm) - 50 mm] = 0.557 Nm

M_z = 0 Nm

Combined load:

$$\frac{|F_{y1}|}{F_{y\max.}} + \frac{|F_{z1}|}{F_{z\max.}} + \frac{|M_{x1}|}{M_{x\max.}} + \frac{|M_{y1}|}{M_{y\max.}} + \frac{|M_{z1}|}{M_{z\max.}}$$

$$= 0 + \frac{7.848\text{N}}{410\text{N}} + \frac{0.2366\text{Nm}}{4.3\text{Nm}} + \frac{0.557\text{Nm}}{1.5\text{Nm}} + 0 = 0.445 \leq 1$$

Mini slides SLT

Technical data

FESTO

Permissible forces and torques						Geometric characteristics	
Piston \varnothing	Stroke	$F_{y_{max}}$ [N]	$F_{z_{max}}$ [N]	$M_{x_{max}}$ [Nm]	$M_{y_{max}}, M_{z_{max}}$ [Nm]	H13 [mm]	L21 [mm]
6							
	10	200	200	1.1	0.7	7	21.5
	20	160	160	1.1	0.7		21.5
	30	140	140	0.7	0.5		21.5
	40	150	150	0.9	0.5		25
	50	190	190	1.4	0.5		30.5
10							
	10	470	470	2.1	1.6	13	24.5
	20	370	370	1.7	1.4		24.5
	30	390	390	2.5	1.4		28.5
	40	350	350	2.2	1.3		28.5
	50	390	390	3.1	1.4		33.5
	80	410	410	4.3	1.5		41
16							
	10	820	820	6.1	4.2	16	33
	20	650	650	4.7	3.4		33
	30	530	530	4.2	3.0		31.5
	40	490	490	3.8	2.7		31.5
	50	510	510	4.6	2.8		35
	80	520	520	6.0	2.8		41.5
	100	600	600	9.1	3.2		51.5
	125	960	960	12.6	3.5		66.5
	150	660	660	12.6	3.5		66.5
20							
	10	1,600	1,600	16	18	16.5	38.5
	20	1,270	1,270	13	14		38.5
	30	1,110	1,110	11	12		38.5
	40	930	930	10	11		38.5
	50	1,080	1,080	9	10		41
	80	1,030	1,030	14	11		48.5
	100	1,160	1,160	18	11		58
	125	1,380	1,380	37	17		71
	150	1,300	1,300	47	17		79
	200	1,170	1,170	64	17		92.5
25							
	10	1,840	1,840	19	21	23.5	45.5
	20	1,460	1,460	16	16		45.5
	30	1,280	1,280	14	14		45.5
	40	1,310	1,310	13	12		45.5
	50	1,080	1,080	12	11		45.5
	80	1,030	1,030	14	11		50.5
	100	1,160	1,160	18	11		60
	125	1,380	1,380	37	17		72.5
	150	1,300	1,300	47	17		80.5
	200	1,170	1,170	64	17		94.5

Mini slides SLT

Technical data

FESTO

Dimensions

Download CAD data → www.festo.com

∅ 6

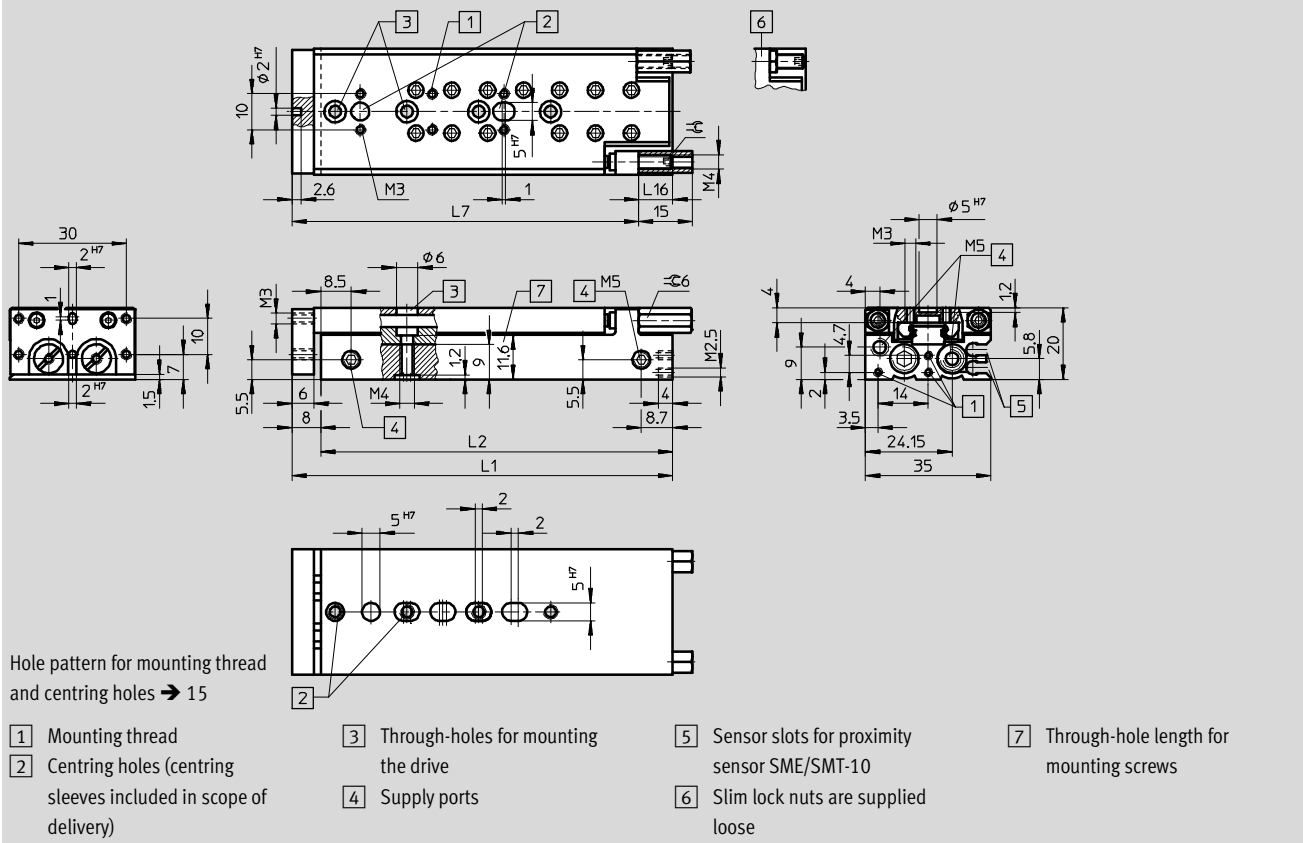

∅	Stroke	L1	L2	L7	L16	≡C
[mm]	[mm]				1)	1)
6	10	48	40	38	14	2
	20	58	50	48		
	30	68	60	58		
	40	85	77	75		
	50	106	98	96		

1) With flexible cushioning

Mini slides SLT

Technical data

Hole pattern for mounting thread and centring holes

SLT-6-10

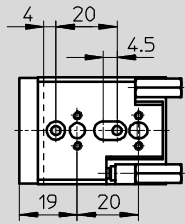

SLT-6-20

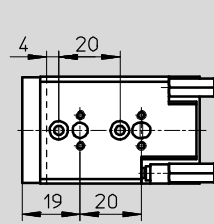

SLT-6-30

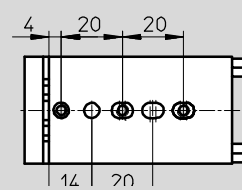
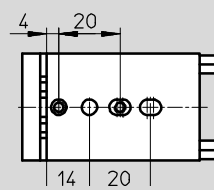
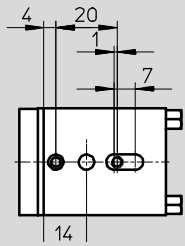
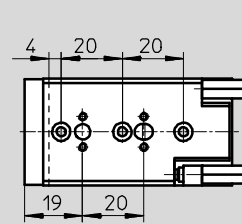

SLT-6-40

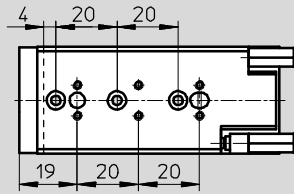

SLT-6-50

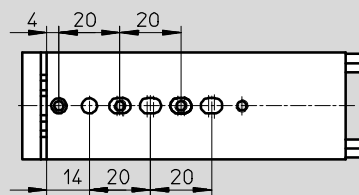
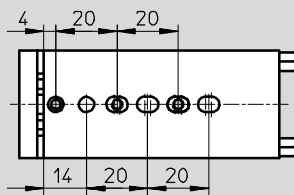
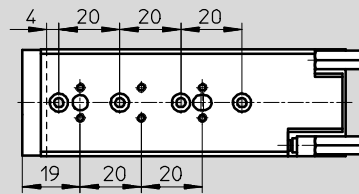

Mini slides SLT

Technical data

FESTO

Dimensions

∅ 10...-25

Download CAD data → www.festo.com

Hole pattern for mounting thread and centring holes → 18

- 1 Mounting thread
- 2 Centring holes (centring sleeves included in scope of delivery)
- 3 Through-holes for mounting the drive
- 4 Supply ports
- 5 Sensor slots for proximity sensor SME/SMT-10
- 6 Slim lock nuts are supplied loose
- 7 Through-hole length for mounting screws

∅	B1	B2	B4	B5	B6	B7	B8	B9	B10	D1	D2	D3	D4	D5	D6	D7
[mm]						H7	H7	H7			∅	∅			∅	
10	50	5.5	10	30	40	5	7	5	20	M5	8	7	M3	M4	5	M3
16	66	6.5	8	50	55	7	9			M6	10	9	M5	M5	7	M4
20	85	7	15	55	70	9	12	9	40	M8	11	12			9	M5
25	104	8	12	80	80	12		12					M6	M6	12	M6

∅	D8	D9	D10	EE	H1	H2	H3	H4	H5	H6	H7	H8	H9	H10	H11	H12
[mm]	∅															
	H7															
10	5	M4	M8x1	M5	30	9.4	5.5	11	20	2	4	10	5	15.15	5.5	1.5
16	5	M5	M10x1		40	13	6.5	13			4.5	15	13	20	6.5	1.5
20	9		M12x1	G ³ / ₈	49	19.5	9	19.7			6	19	16	30.5	9	2.5
25	12	M6	M16x1	G ³ / ₈	60	21	10	21	40		5	25	10	34.5	10	1.5

Mini slides SLT

Technical data

FESTO

∅	Stroke	L1	L2	L3	L4	L7	L8	L9	L10	L14	L15	
[mm]	[mm]									min.		
10	10	72	62	7	11.7	62.5	15	8	10	2	25	
	20	72										72.5
	30	82	72			25						
	40	92	82									
	50	112	102									
	80	162	152									
16	10	80	68	6.7	14.2	63.5	22	10	12	2	32	
	20	87										75
	30		97			85	80.5					
	40	112	100			28						
	50	158	146				134.5					
	80	199	187						176.5			
	100	257	245				233.5					
	125	282	270			258.5						
	150						8.2		16.6			208
									249			
					323							
20	10	97	85	11.5	15.2	74	28	10	12	2	25	
	20											107
	30	122	110			92	37					
	40	167	155						135			
	50	203	191			171						
	80	262	250				208					
	100	302	290			249						
	125	377	365				323					
	150					10.3			17.5			208
	200								249			
									323			
	25	10	108			94	10.7		18.7			88.5
20		118		104	92.5			34				
30			131			117				102.5		
40		177	163	132.5	51							
50		210	196			159.5						
80		264	250	212.5								
100		304	290		252.5							
125		379	365	328.5								
150					10	21.5		212.5		57		
200						252.5						
						328.5						

∅	L16		L17	T1	T2	T3	T4	T5	T6	≈ 1	≈ 2	
	1)	2)									1)	2)
[mm]			min.									
10	21.7	8	1	12	1.5	1.3	7	8	1.2	10	2.5	4
16	23.5	16		16	2.1	1.6	10	7	13	3	5	
20	34	17.5		20	2.6	2.1	10	10	2.1	15	4	6
25	49.5	18		2.6	12	11	2.6	19	5	8		

- 1) With hydraulic shock absorbers
- 2) With flexible cushioning

Mini slides SLT

Technical data



Hole pattern for mounting thread and centring holes

SLT-10-10 ... 30

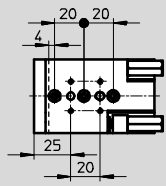

SLT-10-40

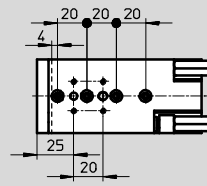

SLT-10-50

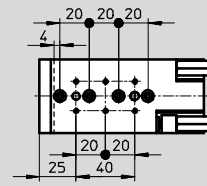

SLT-10-80

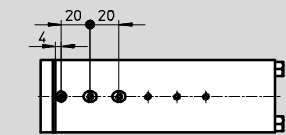
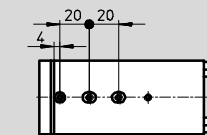
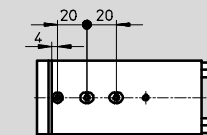
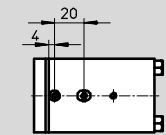
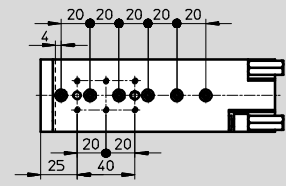

SLT-16-10 ... 40

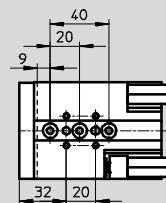

SLT-16-50

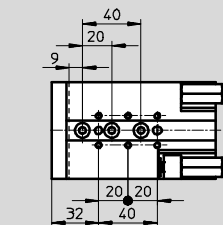

SLT-16-80

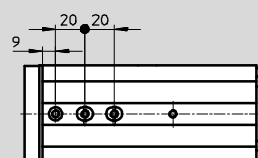
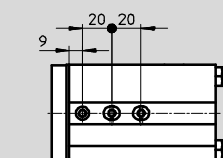
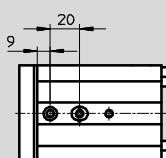
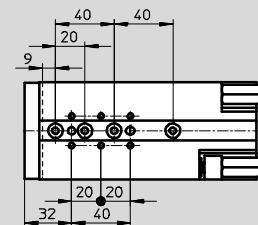

SLT-16-100

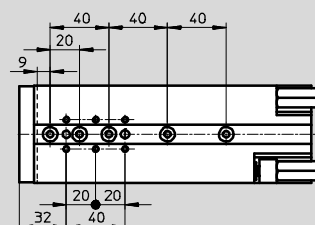

SLT-16-125/-150

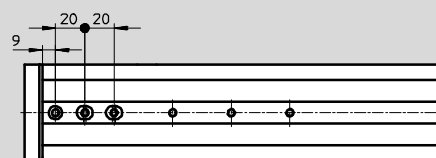
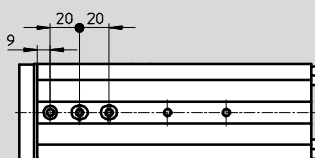
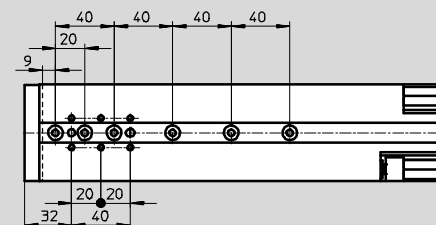

Mini slides SLT

Technical data

Hole pattern for mounting thread and centring holes

SLT-20-10 ... 40

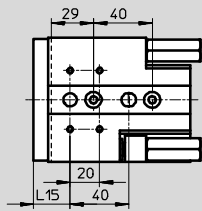

SLT-25-10 ... 40

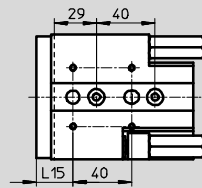

SLT-20/-25-50

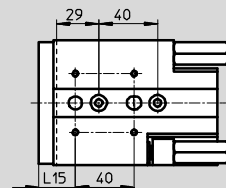

SLT-20/-25-80

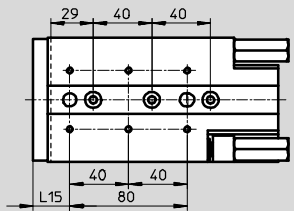

SLT-20/-25-100

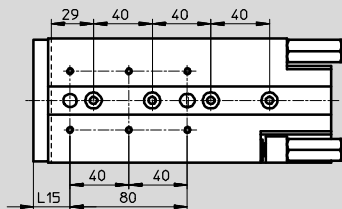

SLT-20/-25-125

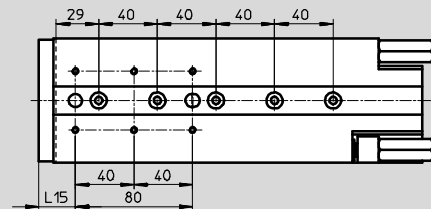

SLT-20/-25-150

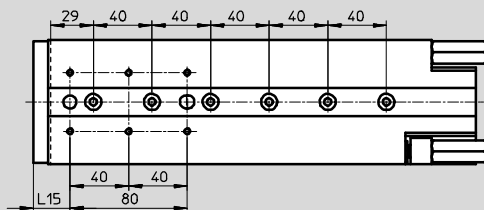

SLT-20/-25-200

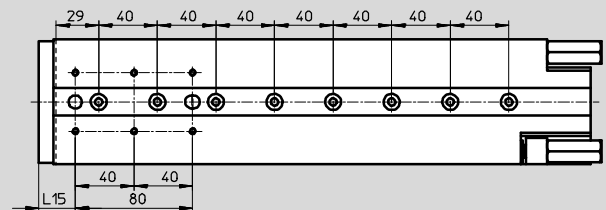

Mini slides SLT

Technical data

FESTO

Ordering data					
∅ [mm]	Stroke [mm]	SLT-...-P-A		SLT-...-A-CC-B	
		Part No.	Type	Part No.	Type
6					
	10	170 549	SLT-6-10-P-A	-	
	20	170 550	SLT-6-20-P-A	-	
	30	170 551	SLT-6-30-P-A	-	
	40	170 552	SLT-6-40-P-A	-	
	50	170 553	SLT-6-50-P-A	-	
10					
	10	170 554	SLT-10-10-P-A	-	
	20	170 555	SLT-10-20-P-A	-	
	30	170 556	SLT-10-30-P-A	197 891	SLT-10-30-A-CC-B
	40	170 557	SLT-10-40-P-A	197 892	SLT-10-40-A-CC-B
	50	170 558	SLT-10-50-P-A	197 893	SLT-10-50-A-CC-B
	80	170 559	SLT-10-80-P-A	197 894	SLT-10-80-A-CC-B
16					
	10	170 560	SLT-16-10-P-A	-	
	20	170 561	SLT-16-20-P-A	-	
	30	170 562	SLT-16-30-P-A	197 895	SLT-16-30-A-CC-B
	40	170 563	SLT-16-40-P-A	197 896	SLT-16-40-A-CC-B
	50	170 564	SLT-16-50-P-A	197 897	SLT-16-50-A-CC-B
	80	170 565	SLT-16-80-P-A	197 898	SLT-16-80-A-CC-B
	100	170 566	SLT-16-100-P-A	197 899	SLT-16-100-A-CC-B
	125	188 412	SLT-16-125-P-A	197 900	SLT-16-125-A-CC-B
	150	188 413	SLT-16-150-P-A	197 901	SLT-16-150-A-CC-B
20					
	10	170 567	SLT-20-10-P-A	-	
	20	170 568	SLT-20-20-P-A	-	
	30	170 569	SLT-20-30-P-A	197 902	SLT-20-30-A-CC-B
	40	170 570	SLT-20-40-P-A	197 903	SLT-20-40-A-CC-B
	50	170 571	SLT-20-50-P-A	197 904	SLT-20-50-A-CC-B
	80	170 572	SLT-20-80-P-A	197 905	SLT-20-80-A-CC-B
	100	170 573	SLT-20-100-P-A	197 906	SLT-20-100-A-CC-B
	125	188 416	SLT-20-125-P-A	197 907	SLT-20-125-A-CC-B
	150	188 417	SLT-20-150-P-A	197 908	SLT-20-150-A-CC-B
	200	188 418	SLT-20-200-P-A	197 909	SLT-20-200-A-CC-B
25					
	10	170 574	SLT-25-10-P-A	-	
	20	170 575	SLT-25-20-P-A	-	
	30	170 576	SLT-25-30-P-A	197910	SLT-25-30-A-CC-B
	40	170 577	SLT-25-40-P-A	197911	SLT-25-40-A-CC-B
	50	170 578	SLT-25-50-P-A	197912	SLT-25-50-A-CC-B
	80	170 579	SLT-25-80-P-A	197913	SLT-25-80-A-CC-B
	100	170 580	SLT-25-100-P-A	197914	SLT-25-100-A-CC-B
	125	188 422	SLT-25-125-P-A	197915	SLT-25-125-A-CC-B
	150	188 423	SLT-25-150-P-A	197916	SLT-25-150-A-CC-B
	200	188 424	SLT-25-200-P-A	197917	SLT-25-200-A-CC-B

Mini slides SLS

Peripherals overview and type codes

Peripherals overview

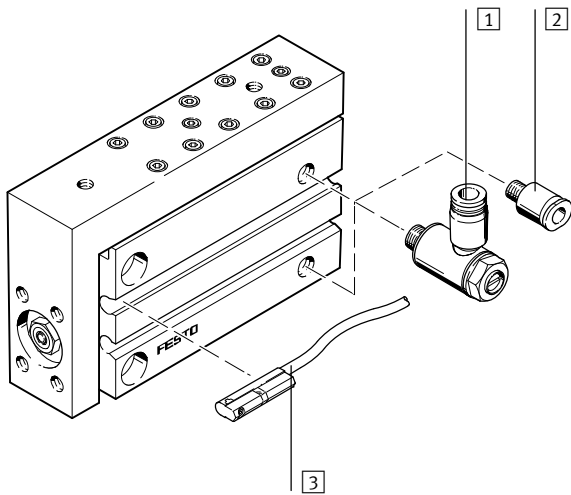

Accessories		Brief description	→ Page/Internet
1	One-way flow control valve GRLA	For speed regulation	38
2	Push-in fitting QS	For connecting compressed air tubing with standard external diameters	quick star
3	Proximity sensor SME/SMT-10	Sensor slots for one or more proximity sensors	39

Type codes

		SLS	-	16	-	10	-	P	-	A
Type										
Double-acting										
SLS	Mini slide									
Piston Ø [mm]										
Stroke [mm]										
Cushioning										
P	Flexible cushioning, non-adjustable									
Position sensing										
A	For proximity sensing									



Mini slides SLS

Technical data

FESTO

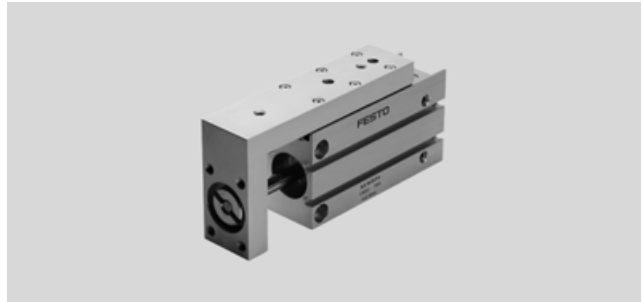
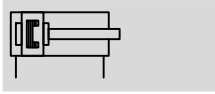
Function



-  - Diameter
6 ... 16 mm
-  - Stroke length
5 ... 30 mm

General technical data				
Piston \varnothing		6	10	16
Pneumatic connection	M5			
Design	Kinematic yoke system			
Guide	Via ball bearings			
Cushioning	Non-adjustable at either end			
Position sensing	For proximity sensing			
Type of mounting	Via through-holes			
	Via female thread			
Assembly position	Any			
Max. advancing speed	[m/s]	0.5 ¹⁾	0.8	
Max. retracting speed	[m/s]	0.5 ¹⁾	0.8	

1) Must be throttled externally

Operating and environmental conditions				
Piston \varnothing		6	10	16
Operating medium	Compressed air in accordance with ISO 8573-1:2010 [7:4:4]			
Note on operating/pilot medium	Operation with lubricated medium possible (in which case lubricated operation will always be required)			
Operating pressure	[bar]	1.5 ... 10	1 ... 10	
Ambient temperature ¹⁾	[°C]	-20 ... +60		

1) Note operating range of proximity sensors

Forces [N] and impact energy [Nm]				
Piston \varnothing		6	10	16
Theoretical force at 6 bar, advancing		17	47	121
Theoretical force at 6 bar, retracting		13	39	104
Max. impact energy at the end positions ¹⁾	Cushioning p ²⁾	0.008	0.05	0.15

1) Loads moved by the slides must be taken into consideration for the calculation of end-position cushioning energy

2) Note also the graph illustrating piston speed as a function of working load → 24

Mini slides SLS

Technical data

Weights [g]				
Piston Ø	Stroke	6	10	16
Product weight	5	97	130	225
	10	104	139	226
	15	113	149	256
	20	120	164	257
	25	131	182	291
	30	141	191	301
Moving load	5	28	41	92
	10	28	44	92
	15	32	49	100
	20	33	51	101
	25	37	60	111
	30	38	62	115

Materials

Sectional view

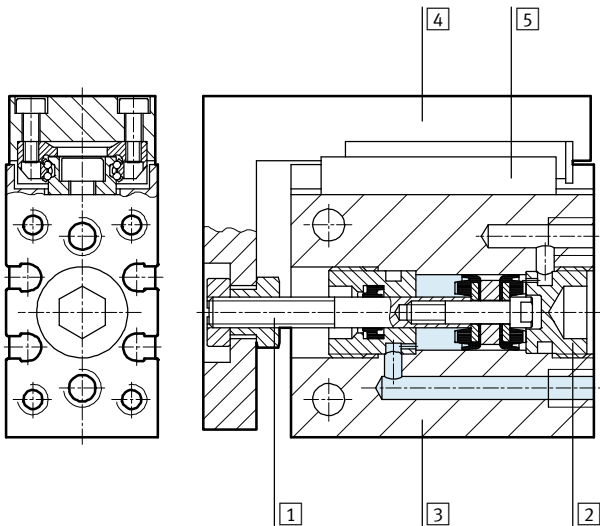

Mini slide		
1	Piston rod	High-alloy steel
2	Cap	Wrought aluminium alloy, anodised
3	Housing	Wrought aluminium alloy, anodised
4	Slide	Wrought aluminium alloy, anodised
5	Guide	Tempered steel
-	Seals	Thermoplastic rubber, hydrogenated nitrile rubber, nitrile rubber
Note on materials		Free of copper, PTFE and silicone

Mini slides SLS

Technical data

Piston speed v as a function of working load m

SLS-6/-10/-16-...-P-A

The piston speed as a function of working load illustrated in this graph may not be exceeded as the kinetic impact or residual energy in the end positions can result in damage to the drive.

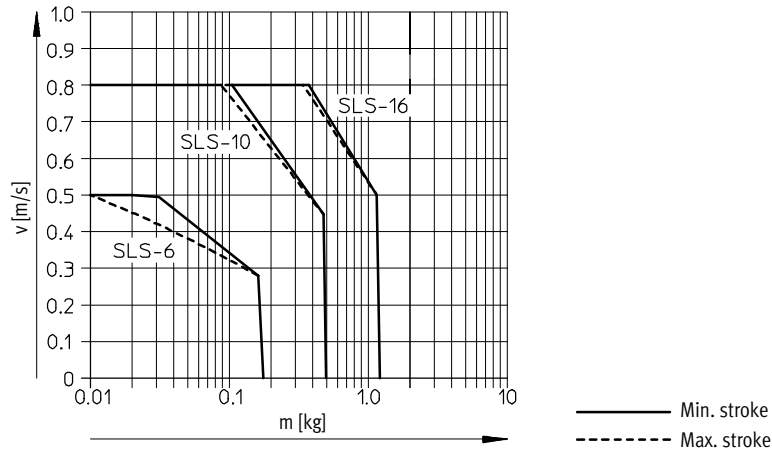

Dynamic characteristic load values

Torques are indicated with reference to the centre of the guide. They must not be exceeded during dynamic operation. Special attention must be paid to the cushioning phase.

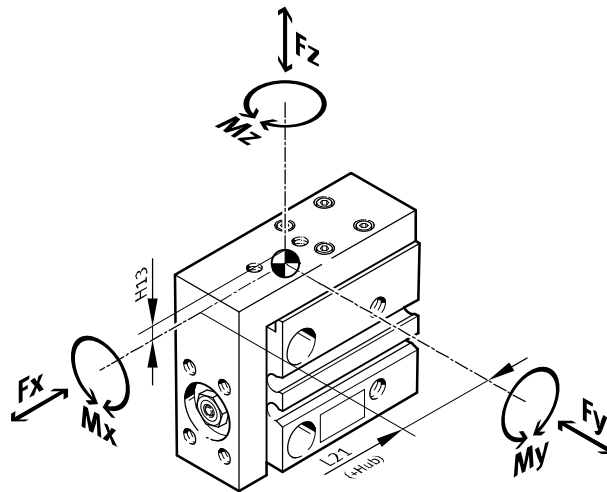

If the drive is simultaneously subjected to several of the indicated forces and torques, the following equation must be satisfied in addition to the indicated maximum loads.

$$\frac{|F_y|}{F_{y_{max}}} + \frac{|F_z|}{F_{z_{max}}} + \frac{|M_x|}{M_{x_{max}}} + \frac{|M_y|}{M_{y_{max}}} + \frac{|M_z|}{M_{z_{max}}} \leq 1$$

Position of guide centre

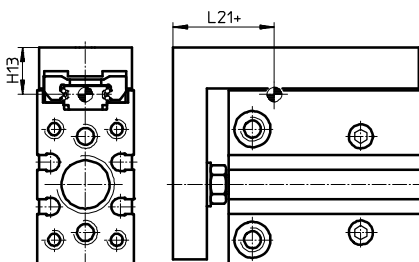

+ plus stroke length

Mini slides SLS

Technical data

FESTO

Permissible forces and torques						Geometric characteristics	
Piston \varnothing	Stroke	$F_{y\max}$ [N]	$F_{z\max}$ [N]	$M_{x\max}, M_{y\max}$ [Nm]	$M_{z\max}$ [Nm]	H13 [mm]	L21 [mm]
6							
	5	220	220	0.6	0.5	8.5	20.5
	10	170	170	0.6	0.5		20.5
	15	180	180	0.9	0.6		23
	20	160	160	0.9	0.6		23
	25	150	150	0.9	0.6		23
	30	140	140	0.9	0.6		23
10							
	5	220	220	0.6	0.5	10	27.5
	10	170	170	0.6	0.5		27.5
	15	170	170	1.1	0.7		36
	20	150	150	1.1	0.7		36
	25	140	140	1.1	0.7		36
	30	130	130	1.1	0.7		36
16							
	5	590	590	2.1	1.6	11	30.5
	10	470	470	2.1	1.6		30.5
	15	410	410	1.7	1.3		30.5
	20	370	370	1.7	1.3		30.5
	25	410	410	2.5	1.4		34
	30	390	390	2.5	1.4		34

Calculation example

Given:

To be found:

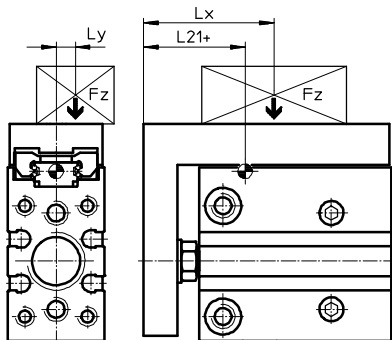

Mini slide = SLS-10
 Stroke length = 20 mm
 Lever arm L_x = 5 mm
 Lever arm L_y = 20 mm
 Mass F_z = 0.495 kg
 Acceleration a = 0 m/s²

F_y, F_z, M_x, M_y, M_z
 and
 verification of function with combined
 load

Solution:

$L_{21} = 36$ mm from table

$F_y = 0$ N

$F_z = m \times g$
 $= 0.495 \text{ kg} \times 9.81 \text{ m/s}^2 = 4.856 \text{ N}$

$M_x = m \times g \times L_y$
 $= 0.495 \text{ kg} \times 9.81 \text{ m/s}^2 \times 20 \text{ mm} = 0.097 \text{ Nm}$

$M_y = m \times g \times [(L_{21} + \text{stroke}) - L_x]$
 $= 0.495 \text{ kg} \times 9.81 \text{ m/s}^2 [(36 \text{ mm} + 20 \text{ mm}) - 5 \text{ mm}] = 0.248 \text{ Nm}$

$M_z = 0$ Nm

Combined load:

$$\frac{|F_y|}{F_{y\max}} + \frac{|F_z|}{F_{z\max}} + \frac{|M_x|}{M_{x\max}} + \frac{|M_y|}{M_{y\max}} + \frac{|M_z|}{M_{z\max}}$$

$$= 0 + \frac{4.856 \text{ N}}{150 \text{ N}} + \frac{0.097 \text{ Nm}}{1.1 \text{ Nm}} + \frac{0.248 \text{ Nm}}{1.1 \text{ Nm}} + 0 = 0.345 \leq 1$$

Mini slides SLS

Technical data

FESTO

Dimensions

Download CAD data → www.festo.com

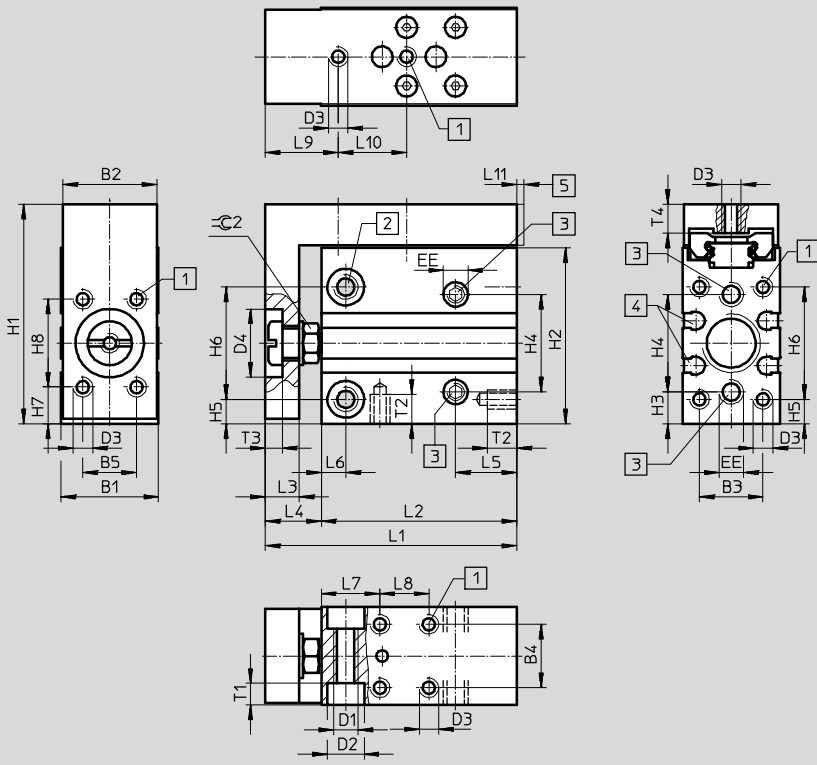

- 1 Mounting thread
- 2 Through and threaded holes for mounting the drive
- 3 Supply ports
- 4 Sensor slots for proximity sensor SME/SMT-10
- 5 Possible protrusion of the slide in relation to the edge of the housing

∅	Stroke	B1	B2	B3	B4	B5	D1	D2	D3	D4	EE	H1
[mm]	[mm]							∅		∅ H11		
6	5	16	15.3	10.5	10	9	M4	6	M3	12	M5	39
	10											
	15											
	20											
	25											
	30											
10	5	20	19.3	13	13	11	M5	7.5	M4	14	M5	45
	10											
	15											
	20											
	25											
	30											
16	5	24	23.3	17	17	16	M5	7.5	M4	19.5	M5	51
	10											
	15											
	20											
	25											
	30											

Mini slides SLS

Technical data

∅	Stroke	H2	H3	H4	H5	H6	H7	H8	L1	L2	L3	L4	L5
[mm]	[mm]												
6	5	31	6	17	5	19	7	15	46	37.5	6	8.5	10
	10								51	42.5			
	15								56	47.5			
	20								61	52.5			
	25								66	57.5			
	30								71	62.5			
10	5	36	6.5	20	5	23	7.5	18	51.5	40	7	11.5	12.5
	10								56.5	45			
	15								61.5	50			
	20								66.5	55			
	25								73.5	62			
	30								78.5	67			
16	5	41	6.5	25	5.5	27	6	26	66	52	10	14	12.5
	10								76	62			
	15								86	72			
	20								91	77			
	25												
	30												

∅	Stroke	L6	L7	L8	L9	L10	L11	T1	T2	T3	T4	≈C 2
[mm]	[mm]											
6	5	4	10	10	13	20	-	3.3	4.8	3	5	7
	10			15		25						
	15			20		30						
	20			25		40						
	25			30								
	30			35								
10	5	5	12	10	15	14	Max. 0.75	4.4	6	3.5	6	8
	10			14		19						
	15			18		25						
	20			24		30						
	25			32		40						
	30			35		45						
16	5	5	12	20	18	24	Max. 0.75	4.4	6	5	6	13
	10			20		35						
	15			30		45						
	20			40		50						
	25			45								
	30			45		55						

Mini slides SLS

Technical data

Ordering data			
∅ [mm]	Stroke [mm]	Part No.	Type
6			
	5	170 485	SLS-6-5-P-A
	10	170 486	SLS-6-10-P-A
	15	170 487	SLS-6-15-P-A
	20	170 488	SLS-6-20-P-A
	25	170 489	SLS-6-25-P-A
	30	170 490	SLS-6-30-P-A
10			
	5	170 491	SLS-10-5-P-A
	10	170 492	SLS-10-10-P-A
	15	170 493	SLS-10-15-P-A
	20	170 494	SLS-10-20-P-A
	25	170 495	SLS-10-25-P-A
	30	170 496	SLS-10-30-P-A
16			
	5	170 497	SLS-16-5-P-A
	10	170 498	SLS-16-10-P-A
	15	170 499	SLS-16-15-P-A
	20	170 500	SLS-16-20-P-A
	25	170 501	SLS-16-25-P-A
	30	170 502	SLS-16-30-P-A

Mini slides SLF

Peripherals overview and type codes

Peripherals overview

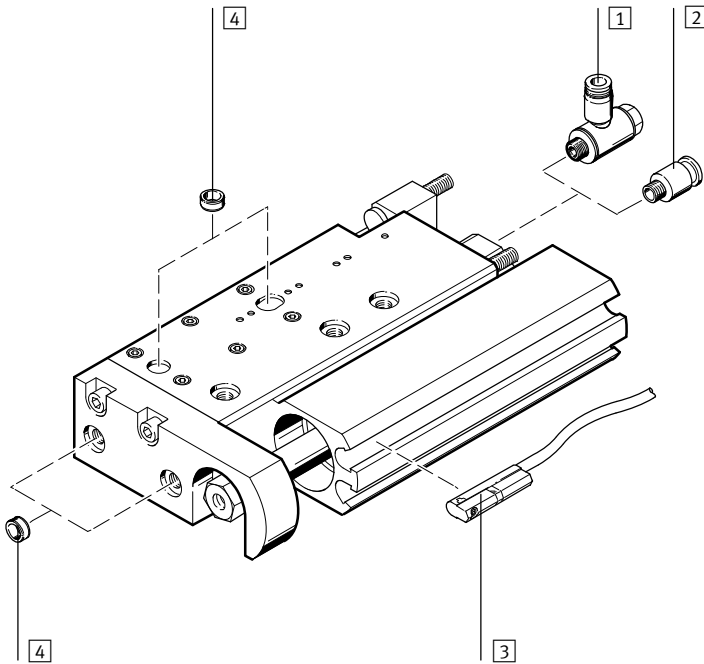

 Note
End stops must not be removed.

Accessories		Brief description	→ Page/Internet
1	One-way flow control valve GRLA	For speed regulation	38
2	Push-in fitting QS	For connecting compressed air tubing with standard external diameters	quick star
3	Proximity sensor SME/SMT-10	Sensor slots for one or more proximity sensors	39
4	Centring pin/sleeve ZBS/ZBH	For centring loads and attachments	38

Type codes

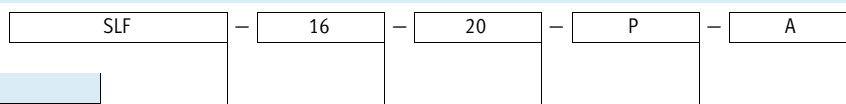

Type	
Double-acting	
SLF	Mini slide

Piston Ø [mm]

Stroke [mm]

Cushioning	
P	Flexible cushioning, non-adjustable

Position sensing	
A	For proximity sensor



Mini slides SLF

Technical data

FESTO

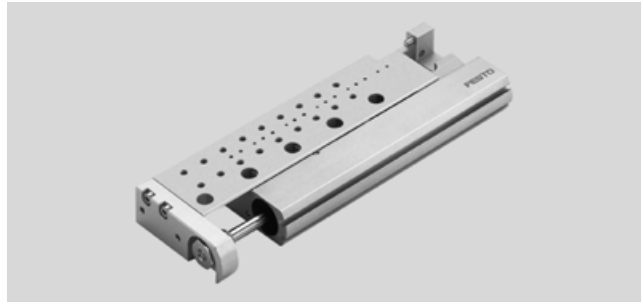
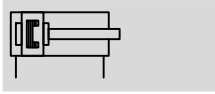
Function



-  - Diameter
6 ... 16 mm
-  - Stroke length
10 ... 80 mm

General technical data			
Piston \varnothing	6	10	16
Pneumatic connection	M5		
Design	Kinematic yoke system		
Guide	Via ball bearings		
Cushioning	Non-adjustable at either end		
Position sensing	For proximity sensing		
Type of mounting	Via through-holes		
	Via female thread		
Assembly position	Any		
Adjustable end-position range	Per end stop	[mm]	5
Max. advancing speed	[m/s]	0.5 ¹⁾	0.8
Max. retracting speed	[m/s]	0.5 ¹⁾	0.8

1) Must be throttled externally

Operating and environmental conditions			
Piston \varnothing	6	10	16
Operating medium	Compressed air in accordance with ISO 8573-1:2010 [7:4:4]		
Note on operating/pilot medium	Operation with lubricated medium possible (in which case lubricated operation will always be required)		
Operating pressure	[bar]	1.5 ... 10	1 ... 10
Ambient temperature ¹⁾	[°C]	-20 ... +60	

1) Note operating range of proximity sensors

Forces [N] and impact energy [Nm]				
Piston \varnothing	6	10	16	
Theoretical force at 6 bar, advancing	17	47	121	
Theoretical force at 6 bar, retracting	13	40	104	
Max. impact energy at the end positions ¹⁾	Cushioning p ²⁾	0.016	0.05	0.1

- 1) Loads moved by the slides must be taken into consideration for the calculation of end-position cushioning energy
- 2) Note also the graph illustrating piston speed as a function of working load → 32

Mini slides SLF

Technical data

Weights [g]				
Piston Ø		6	10	16
Product weight	10	108	135	257
	20	124	156	291
	30	138	171	319
	40	–	178	353
	50	–	227	407
	80	–	–	539
Moving load	10	32	41	99
	20	37	48	109
	30	48	58	122
	40	–	60	133
	50	–	79	153
	80	–	–	199

Materials

Sectional view

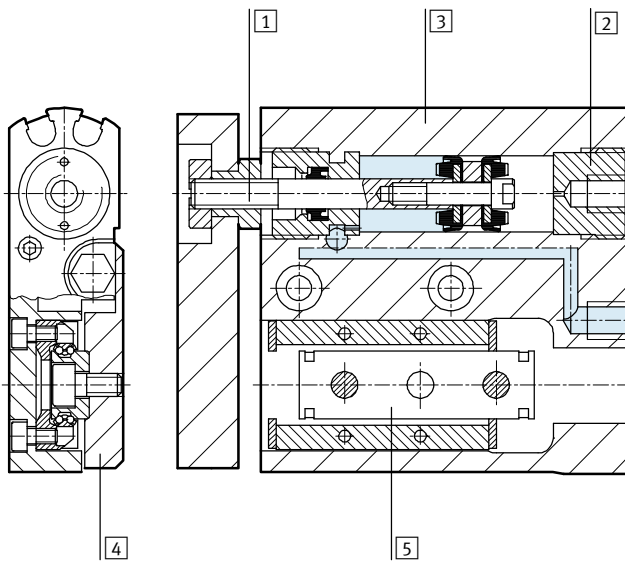

Mini slide		
1	Piston rod	High-alloy steel
2	Cap	Wrought aluminium alloy, anodised
3	Housing	Wrought aluminium alloy, anodised
4	Slide	Wrought aluminium alloy, anodised
5	Guide	Tempered steel
–	Seals	Thermoplastic rubber, hydrogenated nitrile rubber, nitrile rubber
	Note on materials	Free of copper, PTFE and silicone

Mini slides SLF

Technical data

Piston speed v as a function of working load m

SLF-6/-10/-16-...-P-A

The piston speed as a function of working load illustrated in this graph may not be exceeded as the kinetic impact or residual energy in the end positions can result in damage to the drive.

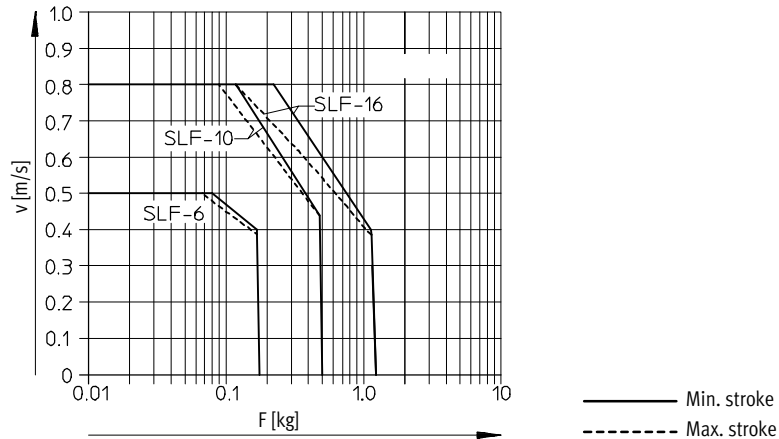

Characteristic load values

Torques are indicated with reference to the centre of the guide.

They must not be exceeded during dynamic operation. Special attention must be paid to the cushioning phase.

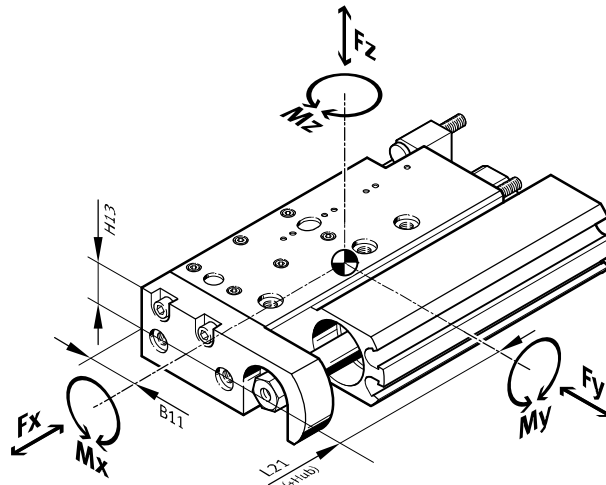

If the drive is simultaneously subjected to several of the indicated forces and torques, the following equation must be satisfied in addition to the indicated maximum loads.

$$\frac{|Fy|}{Fy_{max.}} + \frac{|Fz|}{Fz_{max.}} + \frac{|Mx|}{Mx_{max.}} + \frac{|My|}{My_{max.}} + \frac{|Mz|}{Mz_{max.}} \leq 1$$

Position of guide centre

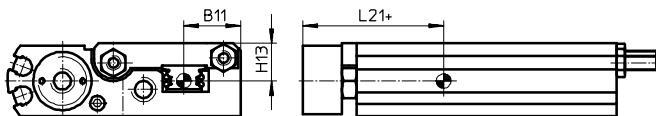

+ plus stroke length

Mini slides SLF

Technical data

FESTO

Permissible forces and torques						Geometric characteristics		
Piston \varnothing	Stroke	$F_{y\max}$ [N]	$F_{z\max}$ [N]	$M_{x\max}, M_{y\max}$ [Nm]	$M_{z\max}$ [Nm]	B11 [mm]	H13 [mm]	L21 [mm]
6								
	10	170	170	0.6	0.5	14	7	22
	20	150	150	1.1	0.7			21
	30	130	130	1.1	0.7			21
10								
	10	170	170	0.6	0.5	11.5	8	23
	20	150	150	1.1	0.7			25
	30	130	130	1.1	0.7			25
	40	150	150	0.9	0.5			29
	50	190	190	1.4	0.5			34.5
16								
	10	470	470	2.1	1.6	14	11.5	27.5
	20	370	370	1.7	1.3			27.5
	30	390	390	2.5	1.4			31.5
	40	350	350	2.2	1.3			31.5
	50	390	390	3.1	1.4			36
	80	410	410	4.3	1.5			43.5

Calculation example

Given:

To be found:

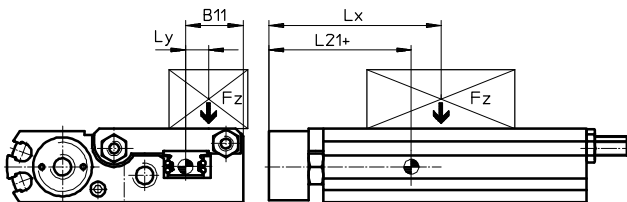

Mini slide = SLF-10
 Stroke length = 20 mm
 Lever arm L_x = 5 mm
 Lever arm L_y = 20 mm
 Mass F_z = 0.495 kg
 Acceleration a = 0 m/s²

F_y, F_z, M_x, M_y, M_z
 and
 verification of function with combined load

Solution:

$L_{21} = 25$ mm from table

$F_y = 0$ N

$F_z = m \times g$
 $= 0.495 \text{ kg} \times 9.81 \text{ m/s}^2 = 4.856$ N

$M_x = m \times g \times L_y$
 $= 0.495 \text{ kg} \times 9.81 \text{ m/s}^2 \times 20 \text{ mm} = 0.097$ Nm

$M_y = m \times g \times [(L_{21} + \text{stroke}) - L_x]$
 $= 0.495 \text{ kg} \times 9.81 \text{ m/s}^2 [(25 \text{ mm} + 20 \text{ mm}) - 5 \text{ mm}] = 0.194$ Nm

$M_z = 0$ Nm

Combined load:

$$\frac{|F_y|}{F_{y\max}} + \frac{|F_z|}{F_{z\max}} + \frac{|M_x|}{M_{x\max}} + \frac{|M_y|}{M_{y\max}} + \frac{|M_z|}{M_{z\max}}$$

$$= 0 + \frac{4.856\text{N}}{150\text{N}} + \frac{0.097\text{Nm}}{1.1\text{Nm}} + \frac{0.194\text{Nm}}{1.1\text{Nm}} + 0 = 0.297 \leq 1$$

Mini slides SLF

Technical data

FESTO

Dimensions

Download CAD data → www.festo.com

∅ 6

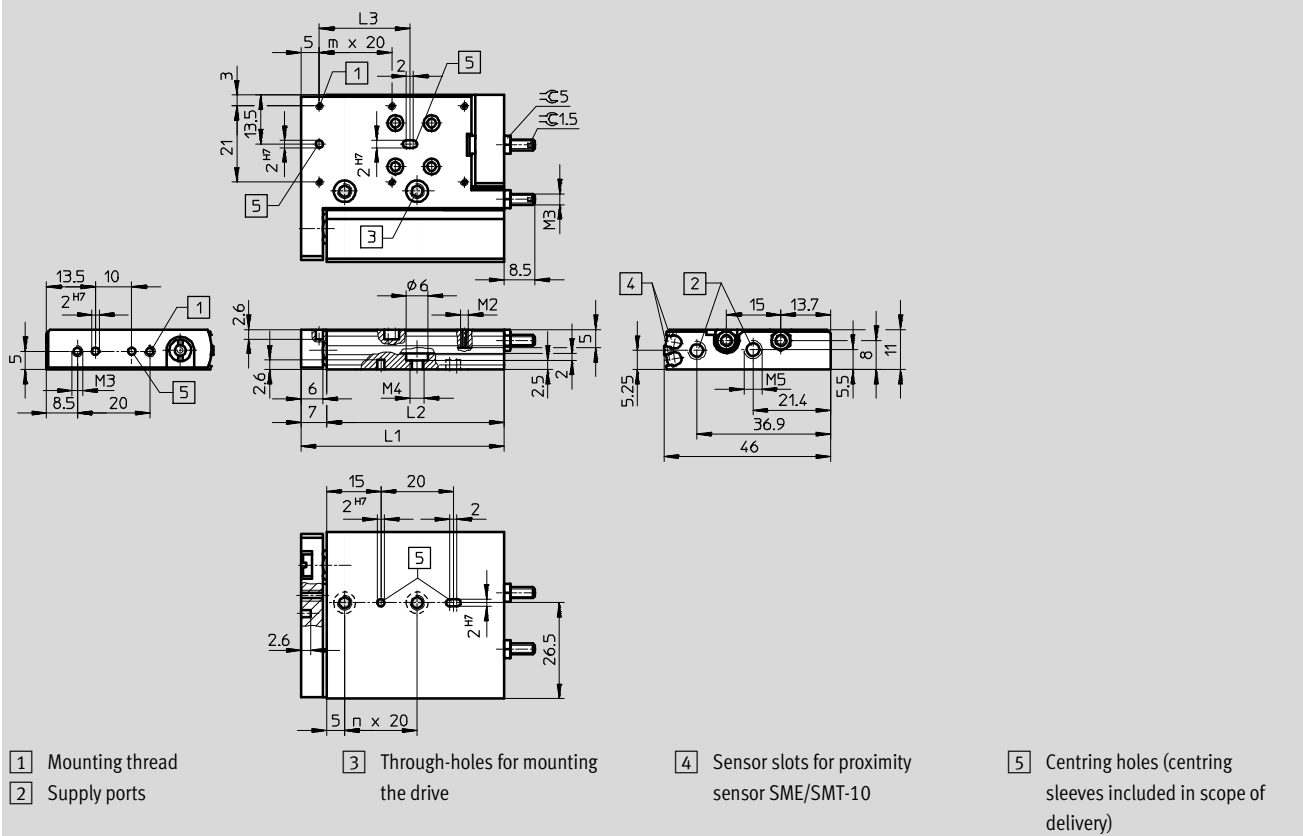

∅	Stroke	L1	L2	L3	m	n
[mm]	[mm]					
6	10	56	49	20	2	1
	20	66	59		2	2
	30	76	69	40	3	

Mini slides SLF

Technical data

Dimensions

Download CAD data → www.festo.com

∅ 10

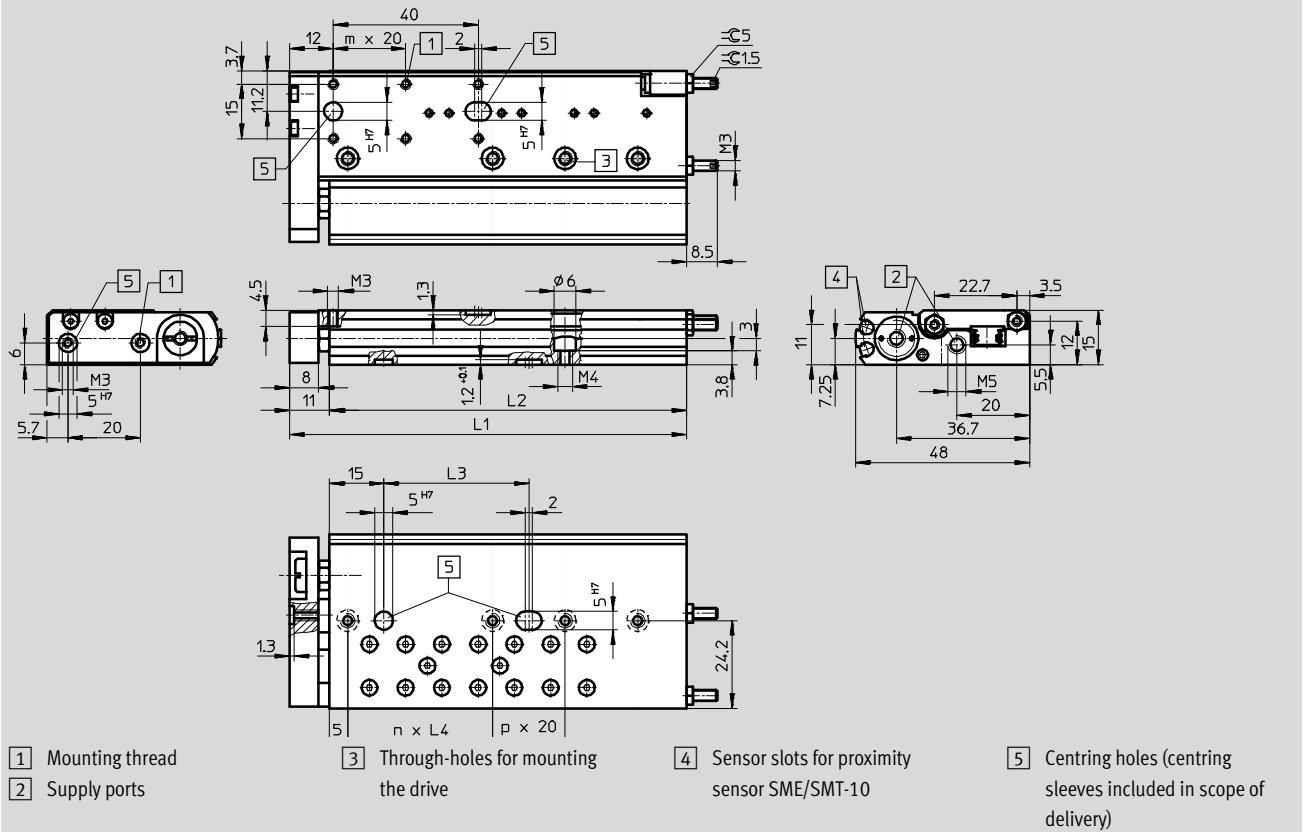

∅	Stroke	L1	L2	L3	L4	m	n	p
[mm]	[mm]							
10	10	59.5	48.5	20	20	1	1	-
	20	69.5	58.5				2	
	30	79.5	68.5			40	40	3
	40	89.5	78.5	1	2			
	50	109.5	98.5					

Mini slides SLF

Technical data

FESTO

Dimensions

Download CAD data → www.festo.com

∅ 16

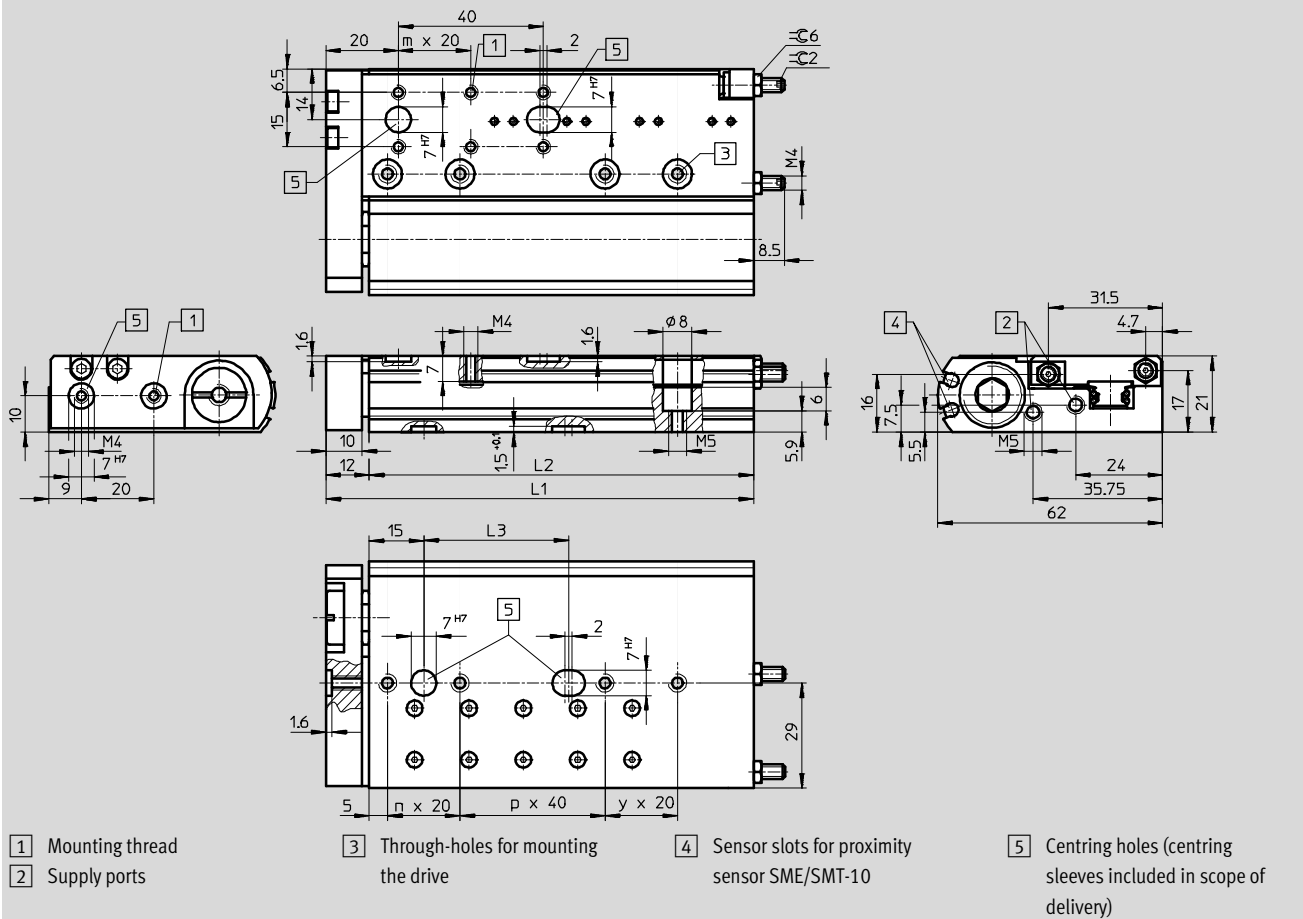

∅	Stroke	L1	L2	L3	m	n	p	y
[mm]	[mm]							
16	10	68	56	20	1	1	-	-
	20	78	66			2		
	30	88	76					
	40	98	86	40	2	3		
	50	118	106			1	1	1
	80	160	148				2	-

Mini slides SLF



Technical data

Ordering data			
∅ [mm]	Stroke [mm]	Part No.	Type
6			
	10	170 503	SLF-6-10-P-A
	20	170 504	SLF-6-20-P-A
	30	170 505	SLF-6-30-P-A
10			
	10	170 506	SLF-10-10-P-A
	20	170 507	SLF-10-20-P-A
	30	170 508	SLF-10-30-P-A
	40	170 509	SLF-10-40-P-A
	50	170 510	SLF-10-50-P-A
16			
	10	170 511	SLF-16-10-P-A
	20	170 512	SLF-16-20-P-A
	30	170 513	SLF-16-30-P-A
	40	170 514	SLF-16-40-P-A
	50	170 515	SLF-16-50-P-A
	80	170 516	SLF-16-80-P-A

Mini slides SLT/SLS/SLF

Accessories

FESTO

Ordering data											
		6		10		16		20		25	
		Part No.	Type	Part No.	Type	Part No.	Type	Part No.	Type	Part No.	Type
Centring pins/sleeves for SLT ¹⁾										Technical data → Internet: zbh	
	Housing	189 652	ZBH-5	186 717	ZBH-7	150 927	ZBH-9	189 653	ZBH-12	189 653	ZBH-12
	Slide	189 652	ZBH-5	189 652	ZBH-5	189 652	ZBH-5	150 927	ZBH-9	189 653	ZBH-12
	Yoke	525 273	ZBS-02	189 652	ZBH-5	186 717	ZBH-7	150 927	ZBH-9	189 653	ZBH-12
Centring pins/sleeves for SLF ¹⁾										Technical data → Internet: zbh	
	Housing	525 273	ZBS-02	189 652	ZBH-5	186 717	ZBH-7	–	–	–	–
	Slide										
	Yoke										
Stop, metallic for SLT...-P-A ²⁾											
	–	539 278	PF-06-SLT	539 279	PF-10-SLT	539 280	PF-16-SLT	539 281	PF-20-SLT	539 282	PF-25-SLT

1) Scope of delivery: 10 per pack

2) Scope of delivery: 2 per pack



Ordering data – One-way flow control valves					Technical data → Internet: grla	
	Connection		Material	Part No.	Type	
	Thread	For tubing O.D.				
	M5	3	Metal design	193 137	GRLA-M5-QS-3-D	
		4		193 138	GRLA-M5-QS-4-D	
	G1/8	4		193 143	GRLA-1/8-QS-4-D	
		6		193 144	GRLA-1/8-QS-6-D	



Mini slides SLT/SLS/SLF

Accessories

FESTO

Ordering data – Proximity sensors for C-slot, magneto-resistive						Technical data → Internet: smt	
	Type of mounting	Switch output	Electrical connection, connection direction	Cable length [m]	Part No.	Type	
N/O contact							
	Insertable in the slot from above	PNP	Cable, 3-wire, in-line	2.5	551 373	SMT-10M-PS-24V-E-2,5-L-OE	
			Plug M8x1, 3-pin, in-line	0.3	551 375	SMT-10M-PS-24V-E-0,3-L-M8D	
			Plug M8x1, 3-pin, lateral	0.3	551 376	SMT-10M-PS-24V-E-0,3-Q-M8D	

Ordering data – Proximity sensors for C-slot, magnetic reed						Technical data → Internet: sme	
	Type of mounting	Switch output	Electrical connection, connection direction	Cable length [m]	Part No.	Type	
N/O contact							
	Insertable in the slot from above	Contacting	Plug M8x1, 3-pin, in-line	0.3	551 367	SME-10M-DS-24V-E-0,3-L-M8D	
			Cable, 3-wire, in-line	2.5	551 365	SME-10M-DS-24V-E-2,5-L-OE	
			Cable, 2-wire, in-line	2.5	551 369	SME-10M-ZS-24V-E-2,5-L-OE	
	Insertable in the slot lengthwise	Contacting	Plug M8x1, 3-pin, in-line	0.3	173 212	SME-10-SL-LED-24	
			Cable, 3-wire, in-line	2.5	173 210	SME-10-KL-LED-24	

Ordering data – Connecting cables					Technical data → Internet: nebu	
	Electrical connection, left	Electrical connection, right	Cable length [m]	Part No.	Type	
	Straight socket, M8x1, 3-pin	Cable, open end, 3-wire	2.5	541 333	NEBU-M8G3-K-2.5-LE3	
			5	541 334	NEBU-M8G3-K-5-LE3	
	Angled socket, M8x1, 3-pin	Cable, open end, 3-wire	2.5	541 338	NEBU-M8W3-K-2.5-LE3	
			5	541 341	NEBU-M8W3-K-5-LE3	

Mini slides SLT

Accessories



Adapter kit
HAPS, HMSV

Material:
Wrought aluminium alloy
Free of copper and PTFE
RoHS-compliant



Note

The kit includes the individual mounting interface as well as the necessary mounting material.

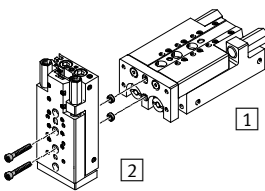
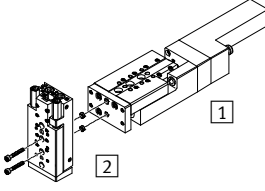
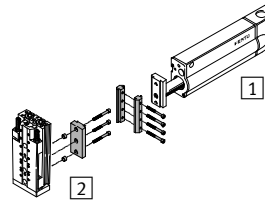
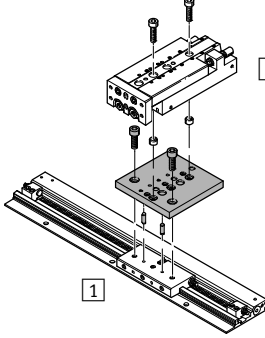
Permissible drive/drive combinations with adapter kit							Download CAD data → www.festo.com	
Combination	1	2	Adapter kit					
	Drive	Drive	CRC ¹⁾	Part No.	Type	Required quantity	PU ²⁾	
	SLT	SLT	2	–	M3x20 DIN 912 ³⁾	2	–	
	10	6		189652	ZBH-5 ⁴⁾	2	10	
	16	10		–	M4x25 DIN 912 ³⁾	2	–	
	20	16		186717	ZBH-7 ⁴⁾	2	10	
	25	20		–	M5x30 DIN 912 ³⁾	2	–	
				150927	ZBH-9 ⁴⁾	2	10	
				–	M6x40 DIN 912 ³⁾	2	–	
				189653	ZBH-12 ⁴⁾	2	10	
	SLTE	SLT	2	–	M3x20 DIN 912 ³⁾	2	–	
	10	6		189652	ZBH-5 ⁴⁾	2	10	
	16	10		–	M4x25 DIN 912 ³⁾	2	–	
				186717	ZBH-7 ⁴⁾	2	10	
	HMP	SLT	2	178329	HMSV-34	1	1	
	16	6		178330	HMSV-35	1	1	
	16, 20	10		178331	HMSV-36	1	1	
	16, 20, 25	16		178332	HMSV-37	1	1	
	20, 25, 32	20		178332	HMSV-37	1	1	
	25, 32	25		178332	HMSV-37	1	1	
	SLG	SLT	2	189533	HAPS-11	1	1	
	8	6		189533	HAPS-11	1	1	
	12	6, 10		189534	HAPS-12	1	1	
	18	10, 16						

1) Corrosion resistance class CRC 2 to Festo standard FN 940070

Moderate corrosion stress. Indoor applications in which condensation may occur. External visible parts with primarily decorative requirements for the surface and which are in direct contact with the ambient atmosphere typical for industrial applications.

2) Packaging unit quantity

3) The screws listed are not included in the scope of delivery of the drives

4) The centring sleeves are included in the scope of delivery of the drives

Mini slides SLT

Accessories



**Adapter kit
HMSV**

Material:
Wrought aluminium alloy
Free of copper and PTFE
RoHS-compliant

 Note
The kit includes the individual mounting interface as well as the necessary mounting material.

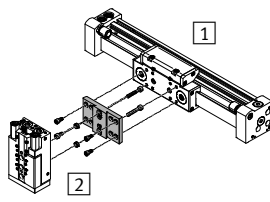
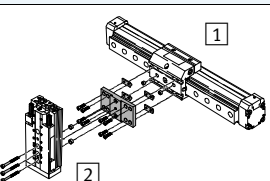
Permissible drive/drive combinations with adapter kit				Download CAD data → www.festo.com			
Combination	1	2	Adapter kit				
	Drive Size	Drive Size	CRC ¹⁾	Part No.	Type	Required quantity	PU ²⁾
DGC/SLT	DGC	SLT	HMSV				
	18	10	2	189656	HMSV-40	1	1
	18	16		189657	HMSV-41	1	1
	25	16		189658	HMSV-42	1	1
	25	20		189659	HMSV-43	1	1
	32	20		189660	HMSV-44	1	1
	32	25		189661	HMSV-45	1	1
	DGP()L, DGE/SLT	DG...		SLT	HMSV		
	18	10	2	189656	HMSV-40	1	1
	18	16		189657	HMSV-41	1	1
	25	16		189658	HMSV-42	1	1
	25	20		189659	HMSV-43	1	1
	32	20		189660	HMSV-44	1	1
	32	25		189661	HMSV-45	1	1

- 1) Corrosion resistance class CRC 2 to Festo standard FN 940070
Moderate corrosion stress. Indoor applications in which condensation may occur. External visible parts with primarily decorative requirements for the surface and which are in direct contact with the ambient atmosphere typical for industrial applications.
- 2) Packaging unit quantity

Mini slides SLF

Accessories



**Adapter kit
HAPS**

Material:
Wrought aluminium alloy
Free of copper and PTFE
RoHS-compliant



Note

The kit includes the individual mounting interface as well as the necessary mounting material.

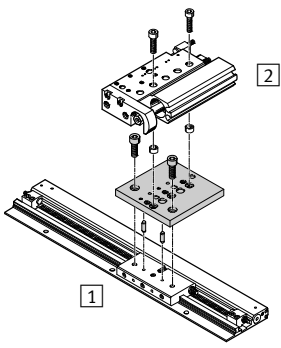
Permissible drive/drive combinations with adapter kit			Download CAD data → www.festo.com				
Combination	[1] Drive	[2] Drive	Adapter kit			Required quantity	PU ²⁾
	Size	Size	CRC ¹⁾	Part No.	Type		
SLG/SLF	SLG	SLF	HAPS				
	8, 12	6, 10	2	189533	HAPS-11	1	1
	12	16		189533	HAPS-11	1	1
	18	10, 16		189534	HAPS-12	1	1

- 1) Corrosion resistance class CRC 2 to Festo standard FN 940070
Moderate corrosion stress. Indoor applications in which condensation may occur. External visible parts with primarily decorative requirements for the surface and which are in direct contact with the ambient atmosphere typical for industrial applications.
- 2) Packaging unit quantity

Product Range and Company Overview

A Complete Suite and Company Overview

Our experienced engineers provide complete support at every stage of your development process, including: conceptualization, analysis, engineering, design, assembly, documentation, validation, and production.



Custom Automation Components
Complete custom engineered solutions



Custom Control Cabinets
Comprehensive engineering support and on-site services



Complete Systems
Shipment, stocking and storage services

The Broadest Range of Automation Components

With a comprehensive line of more than 30,000 automation components, Festo is capable of solving the most complex automation requirements.



Electromechanical
Electromechanical actuators, motors, controllers & drivers



Pneumatics
Pneumatic linear and rotary actuators, valves, and air supply



PLCs and I/O Devices
PLC's, operator interfaces, sensors and I/O devices

Supporting Advanced Automation... As No One Else Can!

Festo is a leading global manufacturer of pneumatic and electromechanical systems, components and controls for industrial automation, with more than 16,000 employees in 60 national headquarters serving more than 180 countries. For more than 80 years, Festo has continuously elevated the state of manufacturing with innovations and optimized motion control solutions that deliver higher performing, more profitable automated manufacturing and processing equipment. Our dedication to the advancement of automation extends beyond technology to the education and development of current and future automation and robotics designers with simulation tools, teaching programs, and on-site services.

Quality Assurance, ISO 9001 and ISO 14001 Certifications

Festo Corporation is committed to supply all Festo products and services that will meet or exceed our customers' requirements in product quality, delivery, customer service and satisfaction.

To meet this commitment, we strive to ensure a consistent, integrated, and systematic approach to management that will meet or exceed the requirements of the ISO 9001 standard for Quality Management and the ISO 14001 standard for Environmental Management.



© Copyright 2013, Festo Corporation. While every effort is made to ensure that all dimensions and specifications are correct, Festo cannot guarantee that publications are completely free of any error, in particular typing or printing errors. Accordingly, Festo cannot be held responsible for the same. For Liability and Warranty conditions, refer to our "Terms and Conditions of Sale", available from your local Festo office. All rights reserved. No part of this publication may be reproduced, distributed, or transmitted in any form or by any means, electronic, mechanical, photocopying or otherwise, without the prior written permission of Festo. All technical data subject to change according to technical update.



Printed on recycled paper at New Horizon Graphic, Inc., FSC certified as an environmental friendly printing plant.

Festo North America

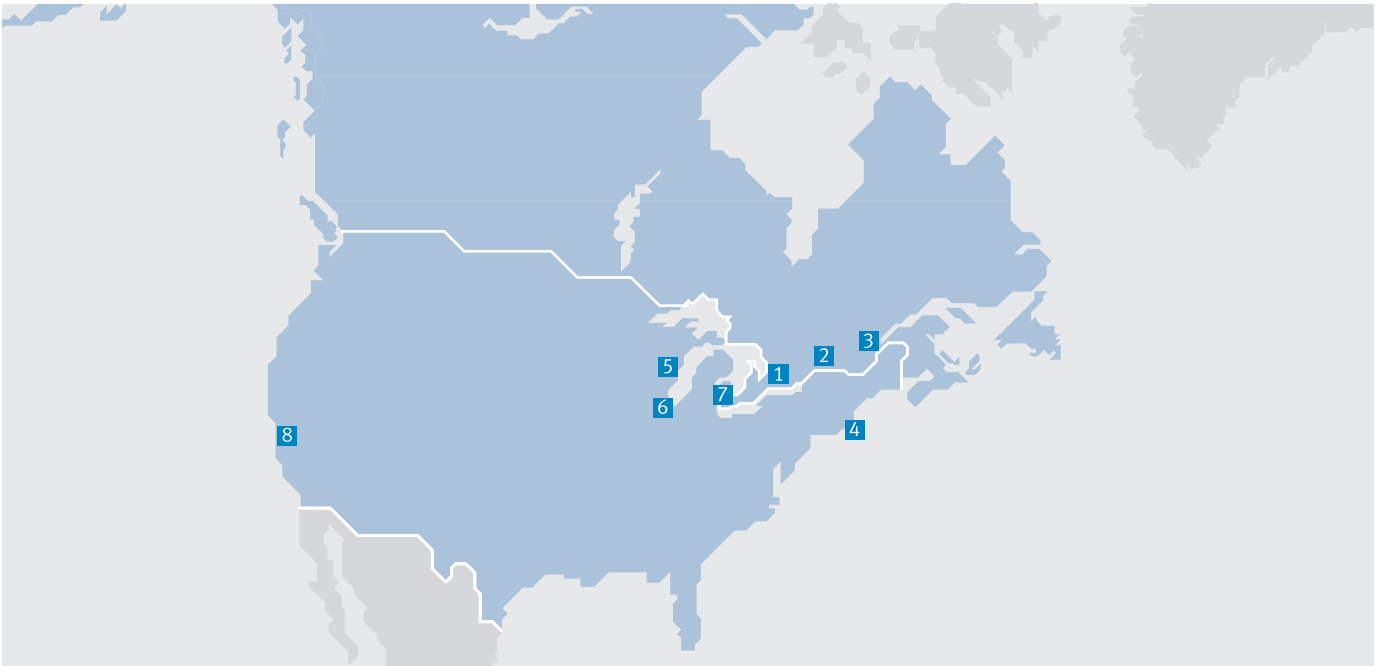

**1 Festo Canada
Headquarters
Festo Inc.**
5300 Explorer Drive
Mississauga, ON
L4W 5G4

2 Montréal
5600, Trans-Canada
Pointe-Claire, QC
H9R 1B6

3 Québec City
2930, rue Watt#117
Québec, QC
G1X 4G3



**4 Festo United States
Headquarters
Festo Corporation**
395 Moreland Road
Hauppauge, NY
11788

5 Appleton
North 922 Tower View Drive, Suite N
Greenville, WI
54942

7 Detroit
1441 West Long Lake Road
Troy, MI
48098

6 Chicago
85 W Algonquin - Suite 340
Arlington Heights, IL
60005

8 Silicon Valley
4935 Southfront Road, Suite F
Livermore, CA
94550

Festo Regional Contact Center

Canadian Customers

Commercial Support:
Tel: 1 877 GO FESTO (1 877 463 3786)
Fax: 1 877 FX FESTO (1 877 393 3786)
Email: festo.canada@ca.festo.com

Technical Support:
Tel: 1 866 GO FESTO (1 866 463 3786)
Fax: 1 877 FX FESTO (1 877 393 3786)
Email: technical.support@ca.festo.com

USA Customers

Commercial Support:
Tel: 1 800 99 FESTO (1 800 993 3786)
Fax: 1 800 96 FESTO (1 800 963 3786)
Email: customer.service@us.festo.com

Technical Support:
Tel: 1 866 GO FESTO (1 866 463 3786)
Fax: 1 800 96 FESTO (1 800 963 3786)
Email: product.support@us.festo.com